

CAST IN-PLACE CONCRETE

- All substructure concrete shall have a compressive strength of 5,000 psi at 28 days.
- All exposed concrete edges shall have a 3/4" x 45 degree chamfer. Chamfer on vertical edges shall be continued a minimum of one foot below finished ground level.

REINFORCING STEEL

- Reinforcement bars, including epoxy coated reinforcement bars, shall conform to the requirements of ASTM A706 Grade 60 deformed bars.
- Cover from the face of concrete to face of reinforcement bars shall be 3" for surfaces cast against earth and 2" for all other surfaces unless shown otherwise.
- Reinforcing bar bending dimensions are out to out.
- Reinforcement bending details shall be in accordance with the "Manual of Standard Practice for Detailing Reinforced Concrete Structures," ACI 315 latest edition.
- Reinforcement bars designated "(E)" shall be epoxy coated.
- Bars noted thus, 3x2-#5 indicates 3 lines of bars with 2 lengths of bars per line.
- Reinforcement bar splices shall be in accordance with the following table, unless shown otherwise on the drawing.

BAR SIZE	CLASS "C" SPLICE BASIC LAP f'c= 5,000 PSI	BAR SIZE	CLASS "C" SPLICE TOP BARS f'c= 5,000 PSI
#4	1'-9"	#4	2'-11"
#5	2'-2"	#5	3'-8"
#6	2'-7"	#6	4'-4"
#7	3'-0"	#7	5'-1"
#8	3'-10"	#8	6'-6"
#9	4'-10"	#9	8'-3"
#10	6'-2"	#10	10'-5"
#11	7'-6"	#11	12'-10"

GENERAL NOTES

- Not used.
- Plan dimensions and details relative to existing structure have been taken from existing plans and are subject to nominal construction variations. It shall be the Contractor's responsibility to verify such dimensions and details in the field and make necessary approved adjustments prior to construction or ordering of materials. Such variations shall not be cause for additional compensation for a change in the scope of work, however, the contractor will be paid for the quantity actually furnished or removed at the unit price.
- Do not scale dimensions for construction.
- No construction joints except those shown on the plans will be allowed unless ordered by the Engineer.
- Temporary soil retention system shall be designed to retain the exposed surface area and the dead load plus live load surcharge. The live load surcharge shall be for Cooper E-90 loading.
- Not used.
- Concrete Sealer shall be applied to the seat area of the east and west abutments and the inside face of both abutment backwalls and front face of abutments and wingwalls.
- The Contractor shall drive test piles to 110% of the nominal required bearing specified in production locations at substructures specified or approved by the Engineer before ordering the remainder of piles.
- It shall be the contractor's responsibility to verify the location of all utilities prior to starting construction. Contact J.U.I.E. at 800-892-0123.
- Upon completion of the bridge, the contractor shall measure the resulting horizontal and vertical clearances and submit them to the engineer for review, and include in the as-built plans.
- Not used.

DESIGNED	KJH
CHECKED	MGB
DRAWN	RJ
CHECKED	BKB

STATE OF ILLINOIS
DEPARTMENT OF TRANSPORTATION

- All construction joints shall be bonded.

STRUCTURAL STEEL

- All structural steel shall conform to ASTM A709, Grade 50 unless otherwise noted on the plans or in the special provisions. Structural steel is to be paid for at the Contract Lump Sum Price for "Furnishing and Erecting Structural Steel".
Calculated Wt of A709 Grade50 steel is-----363,900 lbs.
Calculated Wt of A709 Grade 50W Corrosion Resistant (C.R.) steel is-----89,900 lbs.
Total weight is--453,800 lbs.
- The webs and tension flanges of the through-plate girders, and their bearing stiffeners are designated as "Fracture Critical Members"(FCM) and shall conform to the fracture control plan for fracture critical members of the AREMA specifications for Zone 3. These components are noted on the plans as (FCM). Their fabrication shall conform to Chapter 15, Section 1.14 of the AREMA Specifications.
- The main load carrying member components subject to tensile stress, other than fracture critical members, shall conform to the supplemental requirements for notch toughness, Zone 3. These components are the floor beams and are noted on the plans as (NTR).
- Steel noted on the plans (C.R.) shall be high-strength low-alloy structural steel conforming to ASTM A709, Grade 50W, except as otherwise specified on the plans or special provisions.
- Field welding of construction accessories will not be permitted.
- All shop and field connections shall be bolted with high-strength bolts, except where otherwise shown or noted on the drawings to be bolted with machine bolts or welded. All high-strength bolts, nuts and washers shall conform to ASTM A325 Type 1. Bolts shall be 7/8" diameter unless otherwise noted. Holes shall be 1/16" larger than bolt size unless otherwise noted. Holes for shop fasteners shall be subpunched or drilled and reamed through a template in accordance with AREMA specifications and as specified in the special provisions.
- The Organic zinc-Rich Primer / Epoxy / Urethane Paint System shall be used for painting of new structural steel except where otherwise noted. The entire system shall be shop applied, with the exception that masked off connection surfaces, field installed fasteners and damaged areas shall be touched up in the field. The color of the final finish coat for all interior steel surfaces shall be Gray, Munsell No. 5B 7/1. The color of the final finish coat for the exterior and bottom flange of the fascia beams be (**). See Special Provision for "Cleaning and Painting New Metal Structures".
- Steel deck (to be waterproofed) shall be detailed with countersunk bolt connections.
- The existing structural steel coating may contain lead. The Contractor shall take appropriate precautions to deal with the presence of any lead on this project.

DESIGN CRITERIA

SPECIFICATIONS:
Steel design in accordance with AREMA Specifications for steel structures, dated 2008. Concrete design in accordance with AREMA Specifications for Concrete Structures and Foundations, dated 2008. Workmanship and materials in accordance with the Standard Specifications for Road and Bridge Construction of the State of Illinois, Department of Transportation, adopted Jan 1, 2007. (Including supplemental specifications and recurring special provisions.) Except that wherever applicable, steel fabrication shall be in accordance with the AREMA Specifications. Welding shall be in accordance with the above AREMA Specifications.

LIVE LOAD

Cooper E90 or Alternate Live Load plus Impact for equipment without hammer blow.

MAXIMUM LIVE LOAD PLUS IMPACT DEFLECTION

L/750 for Railroad Super Structure.

ABBREVIATIONS:

PGL Profile Grade Line	WW Wingwall
BF Back Face	NE North East
IF Inside Face	NW North West
OF Outside Face	SE South East
EF Each Face	SW South West
FF Front Face	E Expansion Bearings
WA West Abutment	F Fixed Bearings
EA East Abutment	UNO Unless Noted Otherwise
PJF Preformed Joint Filler	
PJS Preformed Joint Sealer	
EB East Bound	
WB West Bound	
NB North Bound	
SB South Bound	

TOTAL BILL OF MATERIAL

ITEM	UNIT	SUPER	SUB	TOTAL
Porous Granular Embankment	Cu. Yd.	-	255	255
Structure Excavation	Cu. Yd.	-	1,637	1,637
Concrete Structures	Cu. Yd.	-	537	537
Furnishing And Erecting Structural Steel	L. Sum	1	-	1
Reinforcement Bars, Epoxy Coated	Pound	-	70,670	70,670
Pipe Handrail	Foot	284	-	284
Furnishing Steel Piles HPI2X53	Foot	-	1,470	1,470
Driving Piles	Foot	-	1,470	1,470
Test Pile Steel HPI2X53	Each	-	2	2
Name Plates	Each	1	-	1
Name Plates (Special)	Each	1	-	1
Membrane Waterproofing	Sq. Ft.	2,350	-	2,350
Concrete Sealer	Sq. Ft.	-	3,030	3,030
Geocomposite Wall Drain	Sq. Yd.	-	2,095	2,095
Grating	Sq. Ft.	830	-	830
Deck Drains	Foot	240	-	240
Pipe Drains 6"	Foot	-	40	40
Pipe Underdrains for Structures 8"	Foot	-	110	110
Temporary Soil Retention System	L. Sum	-	1	1
Spherical Bearings 800K - Fixed	Each	2	-	2
Spherical Bearings 800K - Expansion	Each	2	-	2
Removal of Existing Structures	Each	1	-	1
Stud Shear Connectors	Each	92	-	92
Pile Shoes	Each	-	70	70

* Excavation within the bracing for the construction of the abutments and wingwalls will be Paid for under the item "Structure Excavation".

** Colors for fascias:

- Interstate Green, Munsell No. 7.5G 4/8.
- Reddish Brown, Munsell No. 2.5YR 3/4.
- Blue, Munsell No. 10B 3/6.
- Gray, Munsell No. 5B 7/1.

INDEX OF SHEETS

S1	General Plan (SN 045-3163)
S2	General Notes & Bill of Material (SN 045-3163)
S3	Construction Staging -1 (SN 045-3163)
S4	Construction Staging -2 (SN 045-3163)
S5	Construction Staging -3 (SN 045-3163)
S6	Framing Plan (SN 045-3163)
S7	Typical Cross Section and Details (SN 045-3163)
S8	Steel Details -1 (SN 045-3163)
S9	Steel Details -2 (SN 045-3163)
S10	Steel Details -3 (SN 045-3163)
S11	Steel Details -4 (SN 045-3163)
S12	Design Data -Stress Tables (SN 045-3163)
S13	Bearing Details (SN 045-3163)
S14	E. & W. Abutment Footings (SN 045-3163)
S15	E. & W. Abutment Details (SN 045-3163)
S16	West Abutment and Details (SN 045-3163)
S17	East Abutment and Details (SN 045-3163)
S18	Temporart Soil retention System (SN 045-3163)
S19	Bridge Drainage Details (SN 045-3163)
S20	Boring data Logs (SN 045-3163)
S21	Boring data Logs (SN 045-3163)

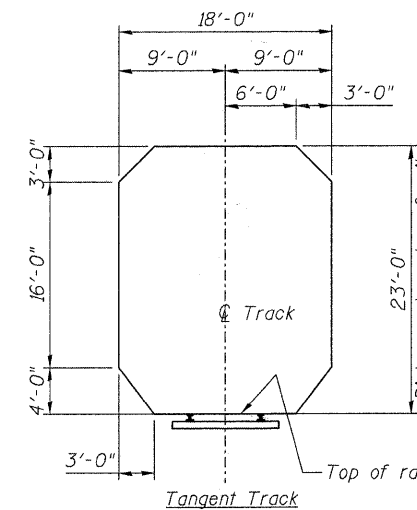

CN STANDARD CLEARANCE DIAGRAM

Note: See Article 1.2.6a for curve corrections.
AREMA Manual for Railway Engineering-Chapter 15.

FREEPORT SUBDIVISION	
BRIDGE NO. W40.07	
SHEET NO. S2	RTE.
	361
S21 SHEETS	SECTION
	06-00214-02-BR
SN 045-3163	
CONTRACT NO. 63073	
FED. ROAD DIST. NO. 1 ILLINOIS FED. AID PROJECT	

**GENERAL NOTES & BILL OF MATERIAL
STRUCTURE NO. 045-3163**



McDonough Associates Inc.
Engineers / Architects
130 East Randolph Street
Chicago, Illinois 60601
(312) 946-8600