

WITNESS MARKER FOR PERMANENT SURVEY MARKERS, TYPE II

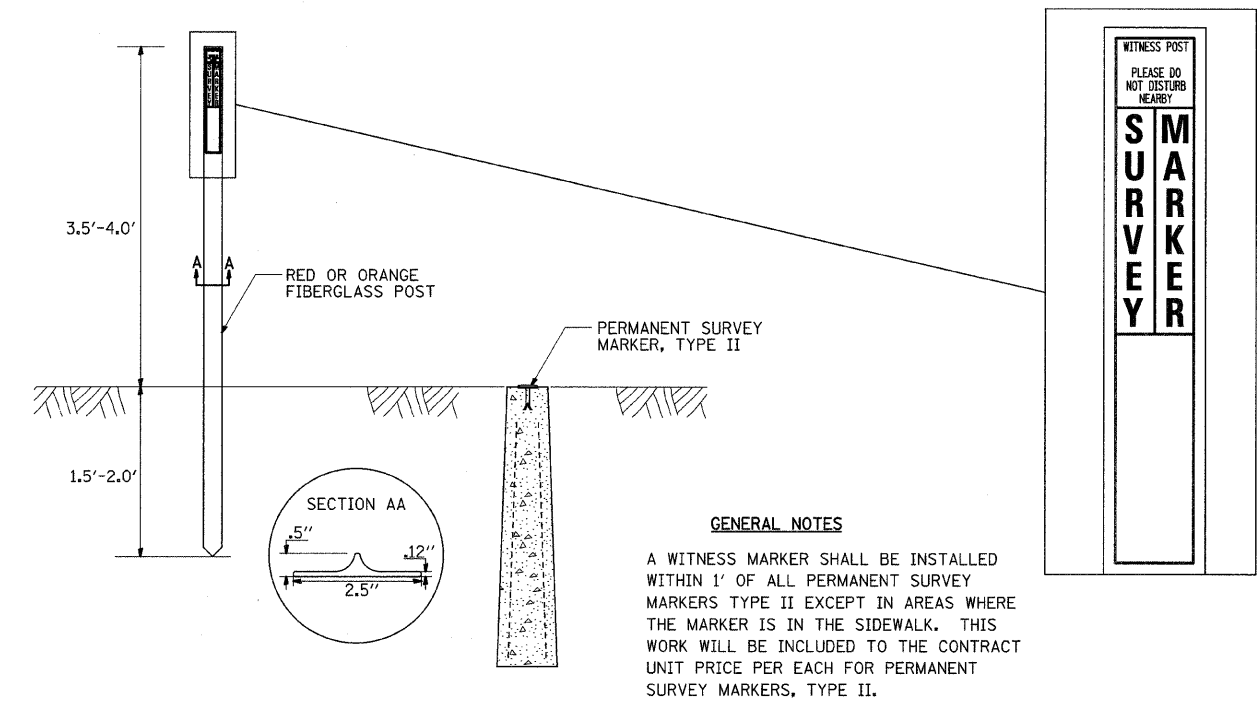

PERMANENT SURVEY MARKERS, TYPE II

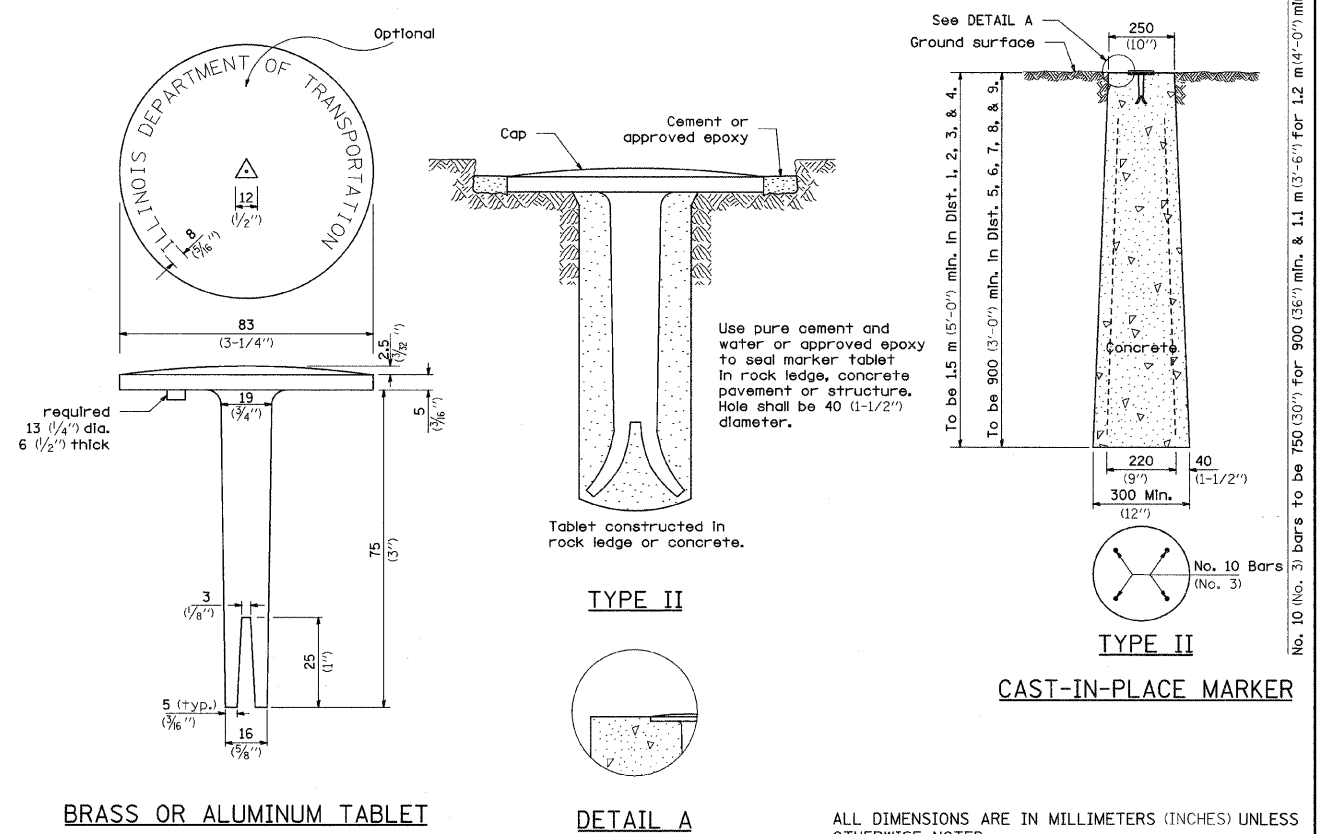

ALL DIMENSIONS ARE IN MILLIMETERS (INCHES) UNLESS OTHERWISE NOTED.

REVISED - 10-21-08	REGION 2 / DISTRICT 2 STANDARD	F.A.P. RTE.	SECTION	COUNTY	TOTAL SHEETS	SHEET NO.	
REVISED -		309	(17)B	WHITESIDE	376	125	
REVISED -		CONTRACT NO. 64B74					
REVISED -		SCALE: 50.0000' = 1"	SHEET NO. OF SHEETS	STA.	TO STA.	FED. ROAD DIST. NO.	ILLINOIS FED. AID PROJECT

PLOT DATE = Fri Mar 13 08:48:11 2009