

FAP 656	FAU 6757	SECTION	COUNTY	TOTAL SHEETS	SHEET NO.
IL 29	US 150	*	TAZEWELL	32	16

\*D-4 STRUCTURE REPAIR 2008

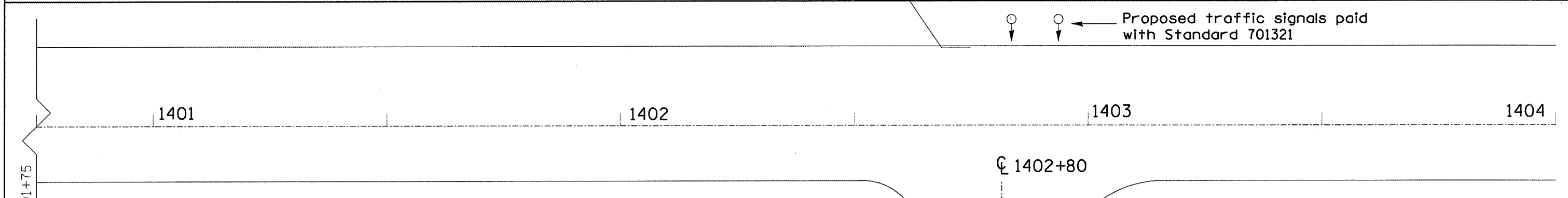
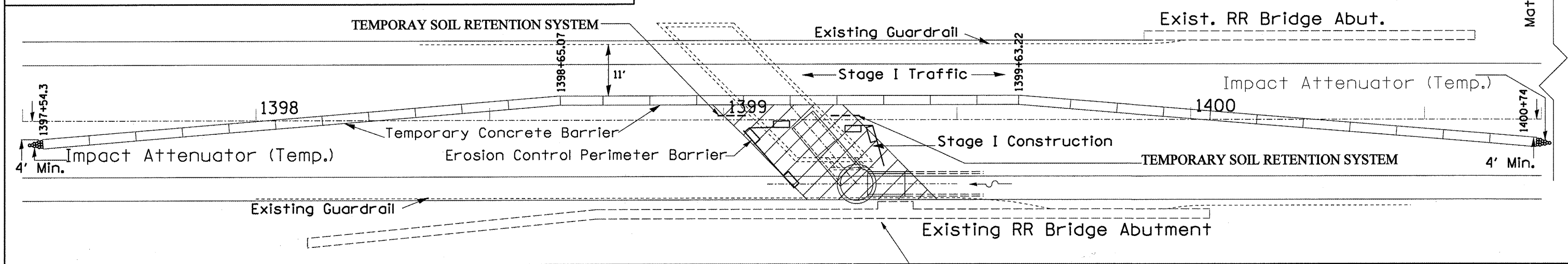
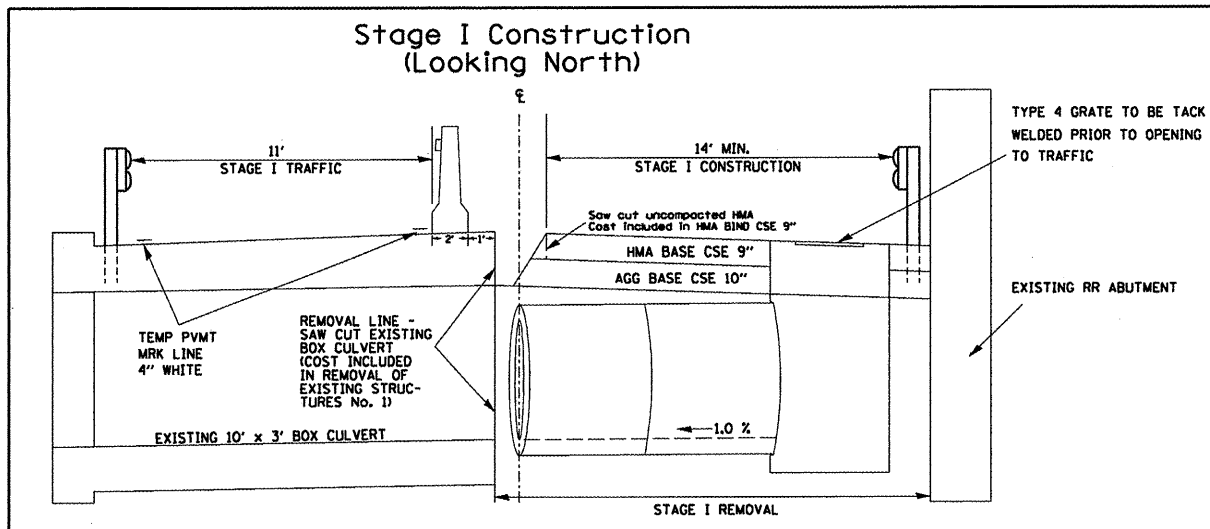

**Stage I Construction**

Saw cut stage line, install temporary concrete barrier wall, signs, and pavement markings as detailed in Standard 701321-10 and as shown on this sheet.

The existing guardrail on the West side is to remain in place during Stage I construction and the new guardrail is to be erected before opening lane to traffic.

Install temporary soil retention system.

The detector loop, signals, signing, and all items required to integrate VFW Road signals with Standard 701321-10 will be included in the cost of Temporary Bridge Traffic Signals and 701321-10 pay item.

Tack weld new Type 4 grate to frame (Cost included in Type 4 Frame & Grate).

Milling and resurfacing (1 1/2") to be done after completion of Stage II.

Using traffic control and protection standard 701306-02

Proposed detector loop. See Stage Construction Notes.

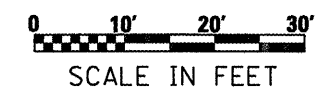

REVISIONS	
NAME	DATE

ILLINOIS DEPARTMENT OF TRANSPORTATION

**STAGE I**  
**IL 29**

DATE \_\_\_\_\_ CHECKED BY \_\_\_\_\_

Matchline 1401+75

Matchline 1401+75