

F.A.I. RTE.	SECTION	COUNTY	TOTAL SHEETS	SHEET NO.
TO		MADISON	420	214
STA.	TO STA.			
FED. ROAD DIST. NO.	ILLINOIS	FED. AID PROJECT		
* 60-10K-1, 60-10HB CONTRACT NO. 76709				

**BILL OF MATERIAL RAMP "B"**

Bar	No.	Size	Length	Shape
a <sub>52</sub> (E)	76	#4	6'-8"	┌
a <sub>53</sub> (E)	76	#4	5'-8"	┌
a <sub>55</sub> (E)	88	#9	34'-9"	┌
a <sub>59</sub> (E)	14	#4	4'-8"	┌
a <sub>60</sub> (E)	14	#4	4'-2"	┌
a <sub>61</sub> (E)	6	#4	4'-8"	┌
a <sub>62</sub> (E)	37	#9	19'-3"	┌
a <sub>63</sub> (E)	12	#9	32'-3"	┌
a <sub>64</sub> (E)	5	#9	25'-11"	┌
a <sub>65</sub> (E)	74	#5	23'-3"	┌
a <sub>66</sub> (E)	31	#5	31'-3"	┌
b <sub>55</sub> (E)	60	#5	5'-3"	┌
b <sub>56</sub> (E)	60	#5	6'-8"	┌
b <sub>59</sub> (E)	10	#5	6'-4"	┌
b <sub>60</sub> (E)	4	#4	5'-10"	┌
b <sub>61</sub> (E)	90	#5	31'-3"	┌
b <sub>62</sub> (E)	24	#4	31'-0"	┌
d(E)	68	#5	3'-2"	┌
d <sub>2</sub> (E)	68	#4	3'-2"	┌
d <sub>52</sub> (E)	66	#5	3'-0"	┌
d <sub>53</sub> (E)	66	#4	3'-0"	┌
e <sub>53</sub> (E)	12	#4	19'-7"	┌
e <sub>54</sub> (E)	4	#8	32'-8"	┌
e <sub>55</sub> (E)	4	#5	31'-6"	┌
e <sub>60</sub> (E)	6	#4	21'-1"	┌
h <sub>50</sub> (E)	6	#5	4'-4"	┌
h <sub>51</sub> (E)	24	#5	4'-4"	┌
h <sub>54</sub> (E)	12	#5	8'-11"	┌
h <sub>55</sub> (E)	18	#5	2'-1"	┌
h <sub>56</sub> (E)	24	#5	4'-6"	┌
h <sub>57</sub> (E)	72	#5	25'-8"	┌

  

* Reinforcement Bars, Epoxy Coated	Pound	26,130
* Concrete	Cu. Yd.	135.4
* Preformed Joint Seal	Foot	83
* Concrete Pad	Sq. Yd.	55
* Polyethylene Bond Breaker	Sq. Yd.	55
Bridge Approach Pavement (Special)	Sq. Yd.	270

\* Items included in the cost for Bridge Approach Pavement, (Special)

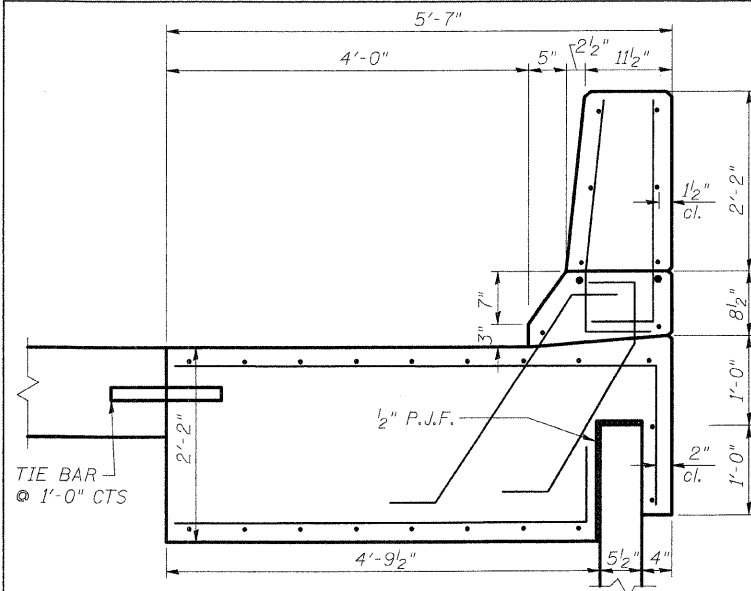

**SECTION K-K**  
(S.N. 060-W003)

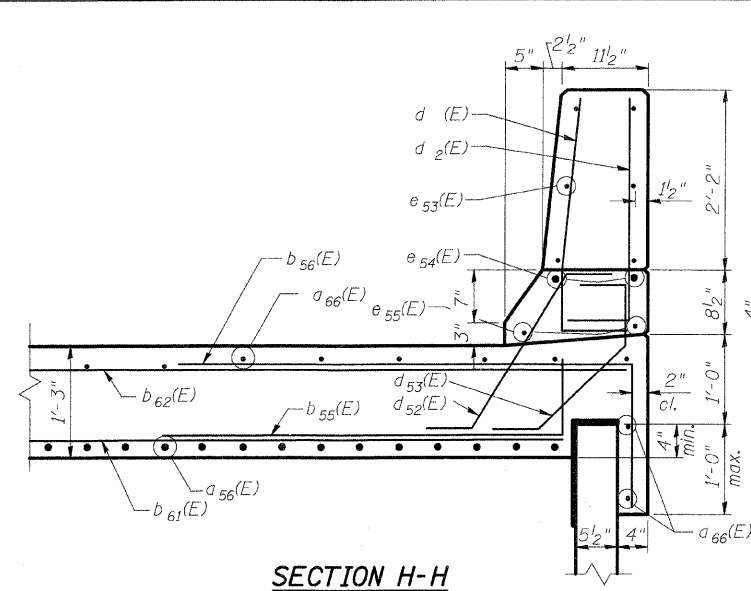

**SECTION H-H**

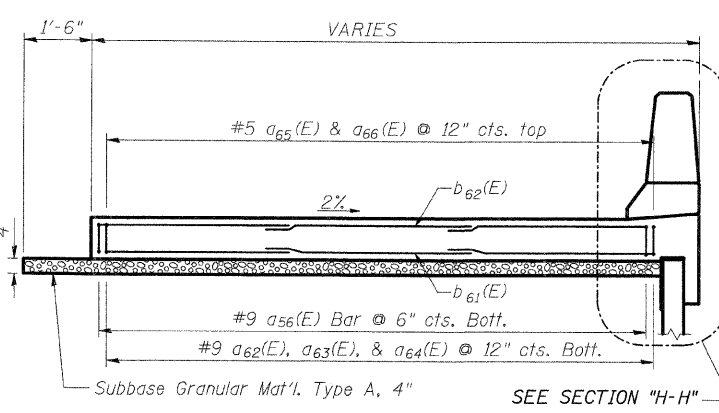

**SECTION B-B**

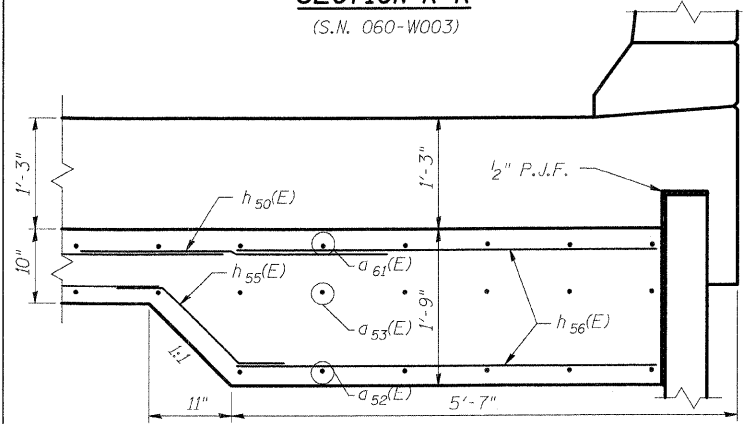

**SECTION L-L**

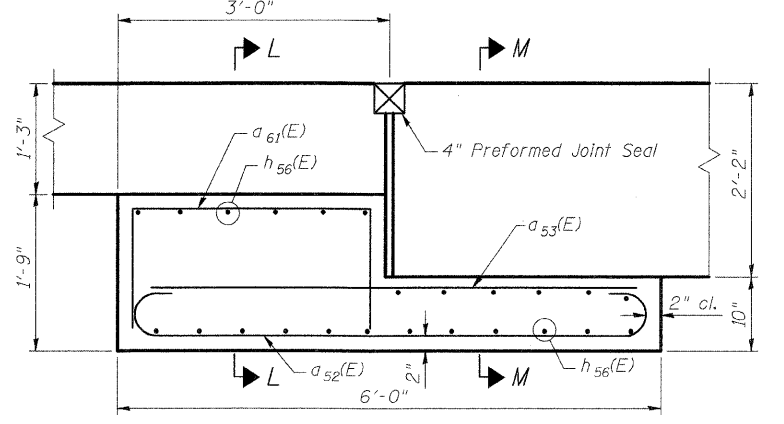

**SECTION E-E**

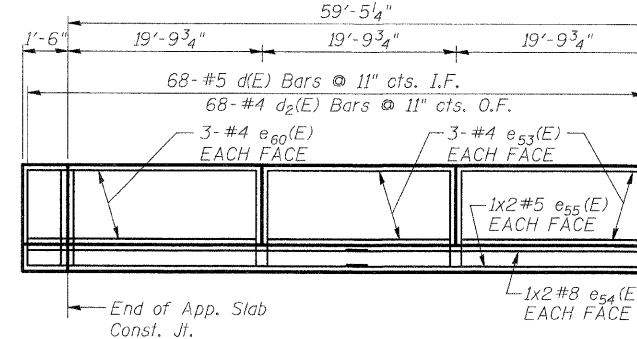

**INSIDE PARAPET ELEVATION AT RAMP "B" APPROACH SLAB (SPECIAL)**

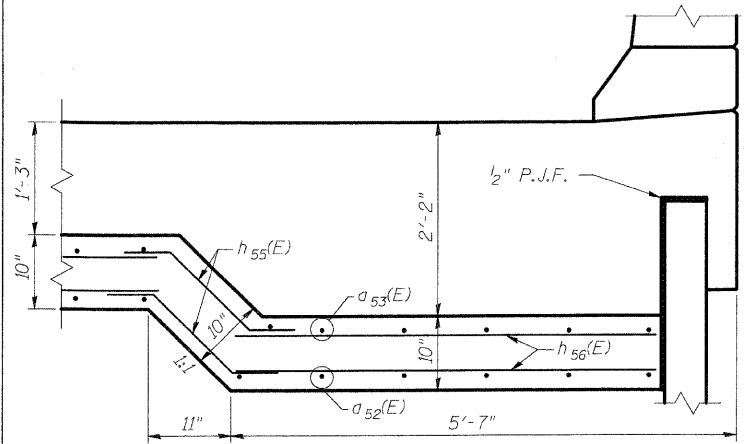

**SECTION M-M**

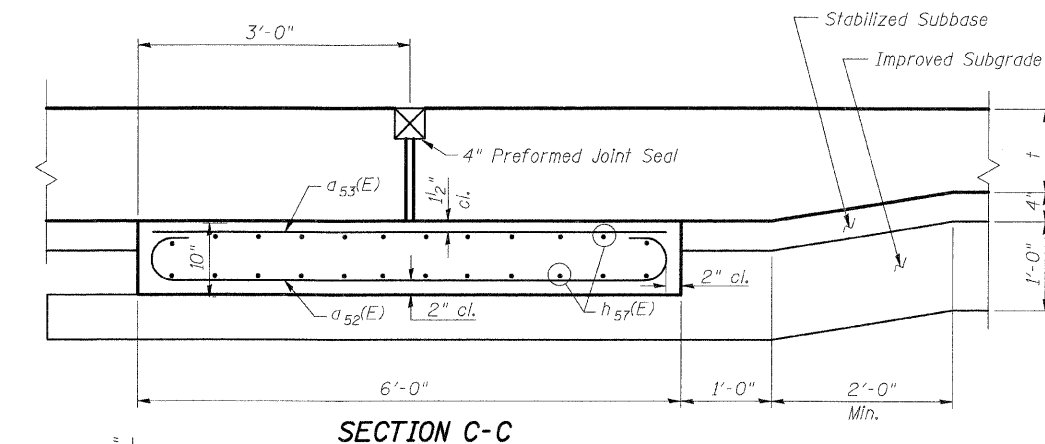

**SECTION C-C**

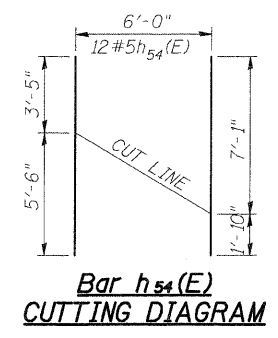

**Bar h54(E) CUTTING DIAGRAM**

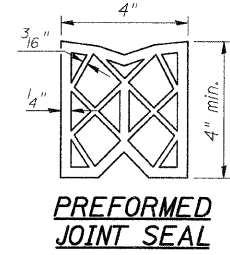

**PREFORMED JOINT SEAL**

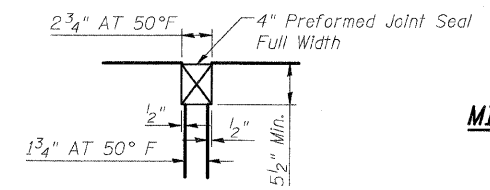

**DETAIL 1**

**MINIMUM BAR LAP**  
#4 bars = 1'-8"  
#5 bars = 2'-2"  
#9 bars = 5'-9"

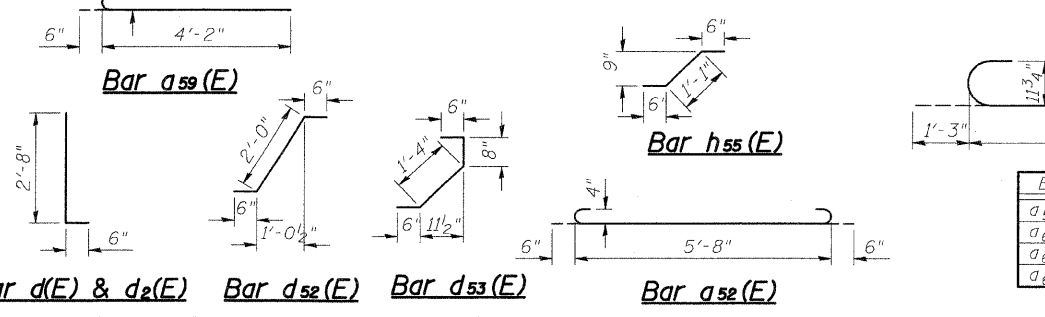
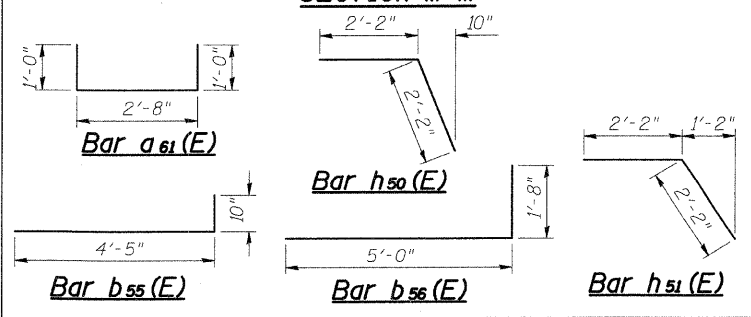

Bar	A
a <sub>56</sub> (E)	33'-6"
a <sub>62</sub> (E)	18'-0"
a <sub>63</sub> (E)	31'-0"
a <sub>64</sub> (E)	24'-8"

SHT. 2 of 2  
**STV Incorporated**  
Engineers/Architects/Planners/Construction Managers  
200 W. Monroe Street, Suite 1650  
Chicago, IL 60606-5015  
312/285-0655, FAX 312/553-0661

REVISIONS	
NAME	DATE

ILLINOIS DEPARTMENT OF TRANSPORTATION  
IL ROUTE 162 OVER I-55/70 IN TROY  
F.A.I. ROUTE 70 SECTION 60-10K-1, 60-10HB  
MADISON COUNTY STATION 499+48.35  
STRUCTURE NO. 060-0338  
**RAMP B APPROACH SLAB DETAILS (SPECIAL)**  
DESIGNED: JAW  
CHECKED: BTO  
DATE: 4/06  
DRAWN: BTO  
CHECKED: JAN