

F.A.I. RTE.	SECTION	COUNTY	TOTAL SHEETS	SHEET NO.
70	60-10K-1,60-10HB	MADISON	420	279
STA.	TO STA.			
FED. ROAD DIST. NO.	ILLINOIS	FED. AID PROJECT		

CONTRACT NO. 76709

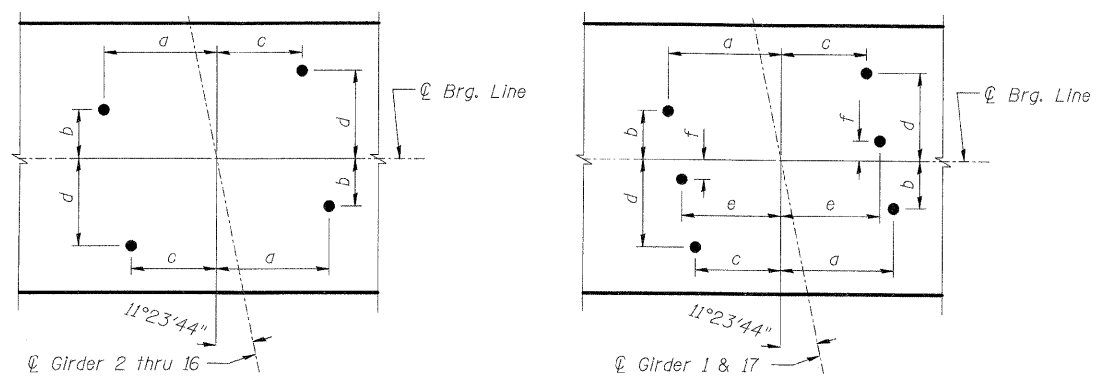

	a	b	c	d	e	f
1,17	14 ¹⁵ / ₁₆ "	6 ⁷ / ₁₆ "	11 ⁵ / ₁₆ "	11 ⁴ / ₁₆ "	13 ¹ / ₁₆ "	2 ⁵ / ₈ "
2,16	11 ⁵ / ₈ "	2 ³ / ₄ "	9 ¹¹ / ₁₆ "	7 ¹ / ₁₆ "	-	-
3-15	9"	3 ¹⁵ / ₁₆ "	6 ¹³ / ₁₆ "	7 ¹ / ₈ "	-	-

ANCHOR BOLT LAYOUT

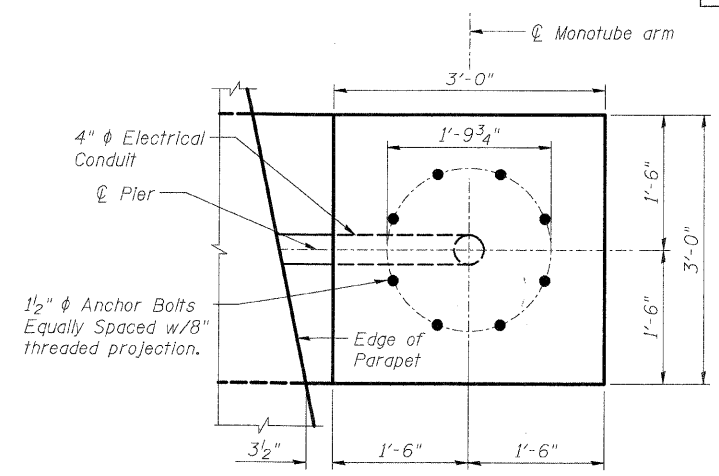

MONOTUBE ANCHOR BOLT LAYOUT

Note: Monotube Anchor bolts shall be ASTM F1554 Grade 55ksi.

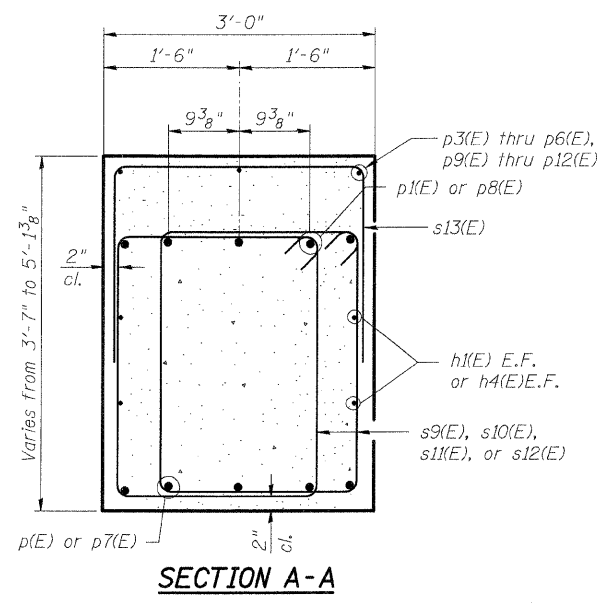

SECTION A-A

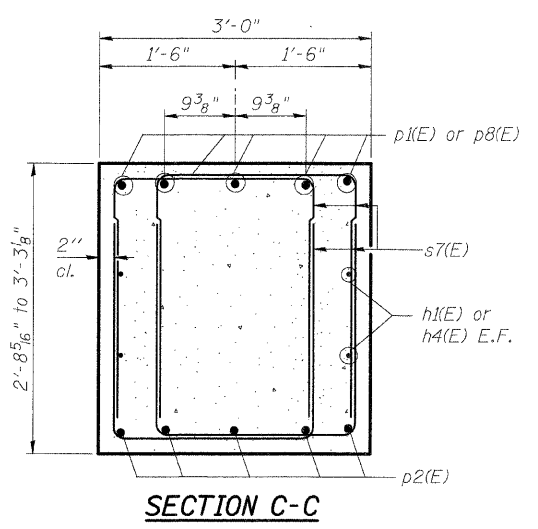

SECTION C-C

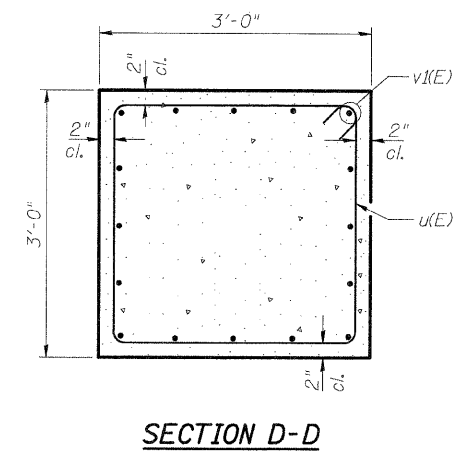

SECTION D-D

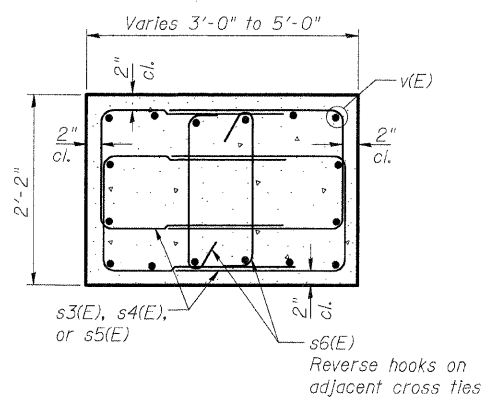

SECTION B-B

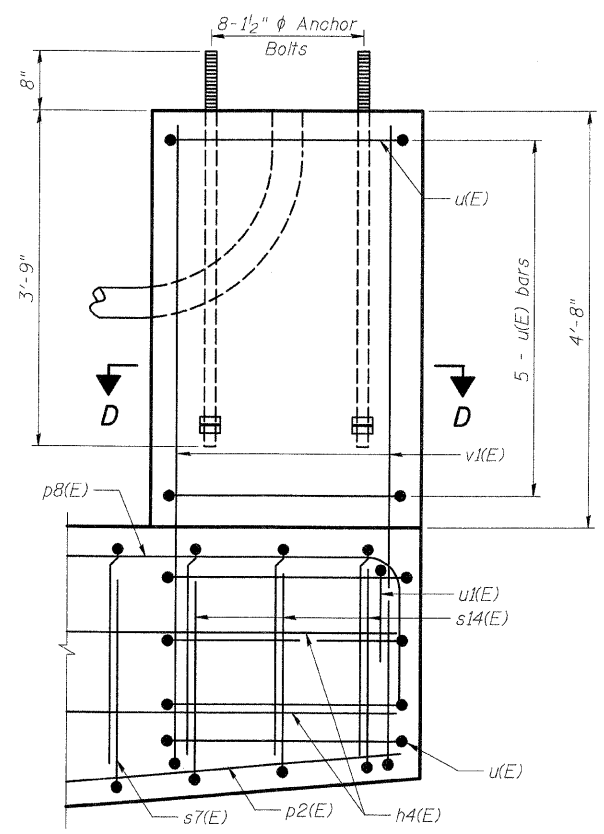

DETAIL 1

South end shown, north end similar

REVISIONS	
NAME	DATE

ILLINOIS DEPARTMENT OF TRANSPORTATION
 IL ROUTE 162 OVER I-55/70 IN TROY
 F.A.I. ROUTE 70 SECTION 60-10K-1, 60-10HB
 MADISON COUNTY STATION 499+48.35
 STRUCTURE NO. 060-0338

PIER DETAILS

DESIGNED: BTO
 CHECKED: AWB
 DRAWN: BTO
 CHECKED: AWB

DATE: 03/06

SHT. S-61 OF S-68

STV Incorporated
 Engineers/Architects/Planners/Construction Managers
 200 W. Monroe Street, Suite 1650
 Chicago, IL 60606-5015
 312/253-0655, FAX 312/553-0661