

GENERAL NOTES

ALL EXCAVATED MATERIAL, WHICH INCLUDES DIGGING OR GRADING OF ANY SOIL OR FILL MATERIAL, WITH THE EXCEPTION OF AGGREGATE FILLS, MUST BE INCORPORATED WITHIN THE IDOT RIGHT OF WAY.

COMMITMENTS

IN THE EVENT A PERMANENT SURVEY MARKER (PSM) IS FOUND IN A PROPOSED PATCH LOCATION, THE LOCATION INFORMATION SHALL BE DOCUMENTED BY THE ENGINEER AND THE DISTRICT LAND ACQUISITION SECTION SHALL BE NOTIFIED FOR IT'S REPLACEMENT

**STATE OF ILLINOIS
DEPARTMENT OF TRANSPORTATION
DISTRICT THREE
AS BUILT INFORMATION**

SUPERVISING CONSTRUCTION FIELD ENGINEER

RESIDENT ENGINEER / TECHNICIAN

**START & END DATES
OF CONSTRUCTION:**

INSPECTORS:

MODEL: Default
FILE NAME: c:\p\work\pww\idot\illinois.gov_oladete.o.popoola@illinois.gov\100056966R53.dgn

USER NAME = Oladete,O.Popoola	DESIGNED - OP	REVISED -
	DRAWN - RW	REVISED -
	CHECKED - JS	REVISED -
PLOT DATE = 3/5/2026	DATE - 2/5/2025	REVISED -

**STATE OF ILLINOIS
DEPARTMENT OF TRANSPORTATION**

GENERAL NOTES

SCALE: SHEET 1 OF 1 SHEETS STA. TO STA.

F.A.P. RTE.	SECTION	COUNTY	TOTAL SHEETS	SHEET NO.
681	(115,116) PP	FORD	9	2
ILLINOIS			CONTRACT NO. 66T29	
FED. AID PROJECT				

CODE NO.	ITEM	UNIT	TOTAL QUANTITY	CONSTRUCTION CODE	
				CONTRACT MAINTENANCE	
				100% STATE	
				ROADWAY	
				0006	
				RURAL	
44201007	CLASS B PATCHES, TYPE II, 13 INCH	SQ YD	983		983
44201298	DOWEL BARS 1 1/4"	EACH	2320		2320
44213200	SAW CUTS	FOOT	5652		5652
67100100	MOBILIZATION	L SUM	1		1
70100600	TRAFFIC CONTROL AND PROTECTION, STANDARD 701336	L SUM	1		1
X7200061	TEMPORARY INFORMATION SIGNING	SQ FT	42		42

MODEL: Default
FILE NAME: c:\p\work\pww\illinois.gov_oladete.o.popoola@illinois.gov\1000568966R53.dgn

USER NAME = Oladete,O.Popoola	DESIGNED - OP	REVISED -
	DRAWN - RW	REVISED -
	CHECKED - JS	REVISED -
PLOT DATE = 3/5/2026	DATE - 2/5/2025	REVISED -

**STATE OF ILLINOIS
DEPARTMENT OF TRANSPORTATION**

SUMMARY OF QUANTITIES

SCALE: SHEET 1 OF 1 SHEETS STA. TO STA.

F.A.P. RTE.	SECTION	COUNTY	TOTAL SHEETS	SHEET NO.
681	(115,116) PP	FORD	9	3
ILLINOIS			CONTRACT NO. 66T29	
FED. AID PROJECT				

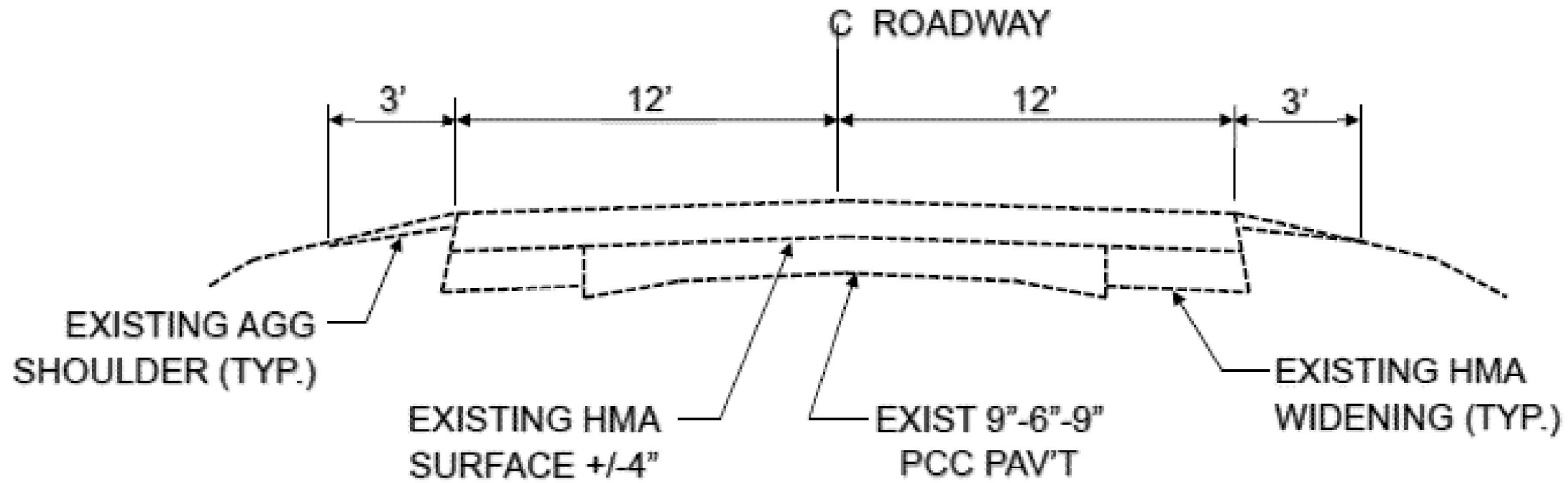

TYPICAL SECTION
L.M. 0.00 TO L.M. 6.00

MODEL: Default
 FILE NAME: c:\p\work\pav\illinois.gov_oladete.o.popoola@illinois.gov\100056966R53.dgn

USER NAME = Oladete,O.Popoola	DESIGNED - OP	REVISED -
	DRAWN - RW	REVISED -
	CHECKED - JS	REVISED -
PLOT DATE = 3/5/2026	DATE - 2/5/2025	REVISED -

**STATE OF ILLINOIS
 DEPARTMENT OF TRANSPORTATION**

TYPICAL SECTION			
SCALE:	SHEET 1	OF 1 SHEETS	STA. TO STA.

F.A.P. RTE. 681	SECTION (115,116) PP	COUNTY FORD	TOTAL SHEETS 9	SHEET NO. 4
CONTRACT NO. 66T29				
ILLINOIS FED. AID PROJECT				

PATCHING SCHEDULE

LOCATION	EASTBOUND LANE					WESTBOUND LANE				
	PATCH LENGTH	PATCH WIDTH	CLASS B TYPE	DOWEL BARS	SAW CUTS	PATCH LENGTH	PATCH WIDTH	CLASS B TYPE	DOWEL BARS	SAW CUTS
			II 13"	1½"				II 13"	1½"	
LOG MILE	FOOT	FOOT	SQ YD	EACH	FOOT	FOOT	SQ YD	SQ YD	FOOT	
0.00	FORD/IROQUOIS COUNTY LINE (1800E RD.)									
0.07	6	12	8	20	48	6	12	8	20	48
0.08	6	12	8	20	48	6	12	8	20	48
0.17	6	12	8	20	48	6	12	8	20	48
0.20	8	12	11	20	52	8	12	11	20	52
0.34	6	12	8	20	48	6	12	8	20	48
0.34	6	12	8	20	48					
0.42	6	12	8	20	48	6	12	8	20	48
0.42	6	12	8	20	48	6	12	8	20	48
0.44	6	12	8	20	48	6	12	8	20	48
0.51	6	12	8	20	48	6	12	8	20	48
0.56	6	12	8	20	48	6	12	8	20	48
0.57	6	12	8	20	48	6	12	8	20	48
0.57	6	12	8	20	48	6	12	8	20	48
0.85	10	12	13	20	56	10	12	13	20	56
0.91	6	12	8	20	48	6	12	8	20	48
1.10	6	12	8	20	48	6	12	8	20	48
1.10	6	12	8	20	48	6	12	8	20	48
1.18	6	12	8	20	48	6	12	8	20	48
1.41	6	12	8	20	48					
1.43						6	12	8	20	48
1.61	6	12	8	20	48	6	12	8	20	48
1.72	10	12	13	20	56	6	12	8	20	48
1.77	8	12	11	20	52					
1.80						8	12	11	20	52
1.86						6	12	8	20	48
2.05	6	12	8	20	48	6	12	8	20	48
2.18	6	12	8	20	48					
2.20						6	12	8	20	48
2.27	6	12	8	20	48	6	12	8	20	48
2.30	6	12	8	20	48	6	12	8	20	48
2.37	6	12	8	20	48	6	12	8	20	48
2.42	6	12	8	20	48	6	12	8	20	48
2.48						6	12	8	20	48
2.49	6	12	8	20	48					
SUBTOTAL			248	580	1416			243	580	1408

MODEL: Default
 FILE NAME: c:\p\work\pav\illinois.gov_oladete.o.popoola@illinois.gov\109056966R53.dgn

USER NAME = Oladete,O.Popoola	DESIGNED - OP	REVISED -
	DRAWN - RW	REVISED -
	CHECKED - JS	REVISED -
PLOT DATE = 3/5/2026	DATE - 2/5/2025	REVISED -

**STATE OF ILLINOIS
DEPARTMENT OF TRANSPORTATION**

SCHEDULES			
SCALE:	SHEET 1	OF 2 SHEETS	STA. TO STA.

F.A.P. RTE.	SECTION	COUNTY	TOTAL SHEETS	SHEET NO.
681	(115,116) PP	FORD	9	5
CONTRACT NO. 66T29				
ILLINOIS FED. AID PROJECT				

PATCHING SCHEDULE

LOCATION	EASTBOUND LANE					WESTBOUND LANE				
	PATCH LENGTH	PATCH WIDTH	CLASS B TYPE	DOWEL BARS	SAW CUTS	PATCH LENGTH	PATCH WIDTH	CLASS B TYPE	DOWEL BARS	SAW CUTS
			II 13"	1 1/4"				II 13"	1 1/4"	
LOG MILE	FOOT	FOOT	SQ YD	EACH	FOOT	FOOT	FOOT	SQ YD	SQ YD	FOOT
2.54	6	12	8	20	48	6	12	8	20	48
2.65	6	12	8	20	48	6	12	8	20	48
2.73	6	12	8	20	48	6	12	8	20	48
3.15	6	12	8	20	48	6	12	8	20	48
3.23	6	12	8	20	48	6	12	8	20	48
3.32	6	12	8	20	48	6	12	8	20	48
3.33	8	12	11	20	52					
3.59	6	12	8	20	48	6	12	8	20	48
3.63						6	12	8	20	48
3.64	10	12	13	20	56					
3.80	6	12	8	20	48	6	12	8	20	48
3.88	10	12	13	20	56	10	12	13	20	56
4.22	6	12	8	20	48	6	12	8	20	48
4.25	6	12	8	20	48	6	12	8	20	48
4.30	6	12	8	20	48	6	12	8	20	48
4.31	6	12	8	20	48	6	12	8	20	48
4.33	6	12	8	20	48	6	12	8	20	48
4.37	6	12	8	20	48	6	12	8	20	48
4.46	6	12	8	20	48	6	12	8	20	48
4.49						6	12	8	20	48
4.58						6	12	8	20	48
4.69	6	12	8	20	48	6	12	8	20	48
4.73	6	12	8	20	48	6	12	8	20	48
4.80	10	12	13	20	56	10	12	13	20	56
4.91	6	12	8	20	48	6	12	8	20	48
5.07	6	12	8	20	48					
5.09						6	12	8	20	48
5.28	6	12	8	20	48	6	12	8	20	48
5.37	6	12	8	20	48	6	12	8	20	48
5.24	6	12	8	20	48	6	12	8	20	48
5.60	6	12	8	20	48	6	12	8	20	48
5.77	6	12	8	20	48					
5.81	6	12	8	20	48	6	12	8	20	48
6.00	LIVINGSTON/FORD COUNTY LINE (1200E RD.)									
SUBTOTAL			250	580	1420			242	580	1408
TOTAL			498	1160	2836			485	1160	2816

MODEL: Default
FILE NAME: c:\p\work\pav\illinois.gov_oladete.o.popoola@illinois.gov\109056966R53.dgn

USER NAME = Oladete,O.Popoola	DESIGNED - OP	REVISED -
	DRAWN - RW	REVISED -
	CHECKED - JS	REVISED -
PLOT DATE = 3/5/2026	DATE - 2/5/2025	REVISED -

**STATE OF ILLINOIS
DEPARTMENT OF TRANSPORTATION**

SCHEDULES

SCALE: SHEET 2 OF 2 SHEETS STA. TO STA.

F.A.P. RTE.	SECTION	COUNTY	TOTAL SHEETS	SHEET NO.
681	(115,116) PP	FORD	9	6
CONTRACT NO. 66T29				
ILLINOIS FED. AID PROJECT				

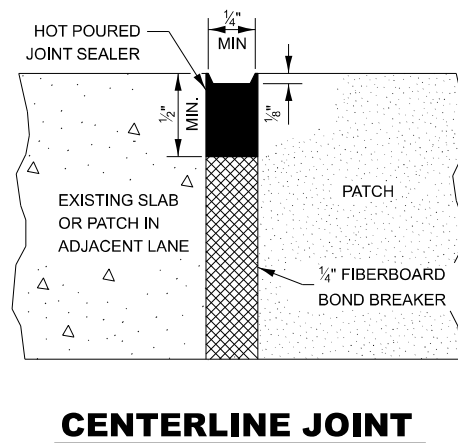
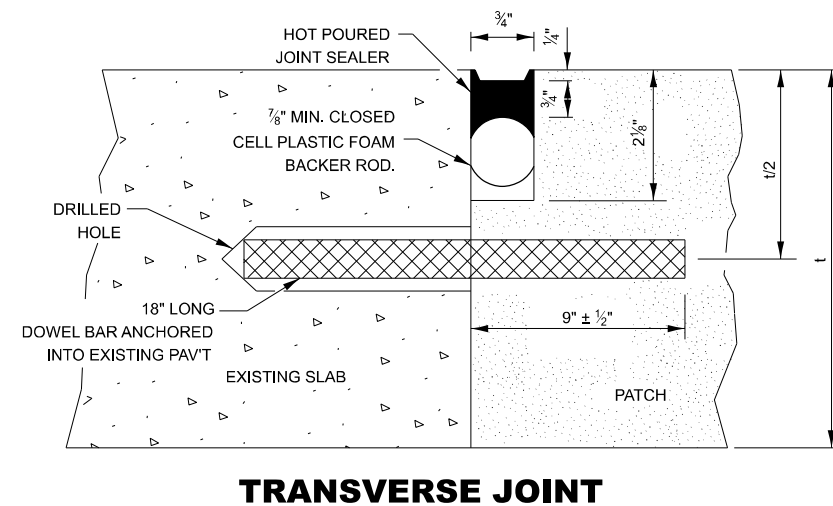
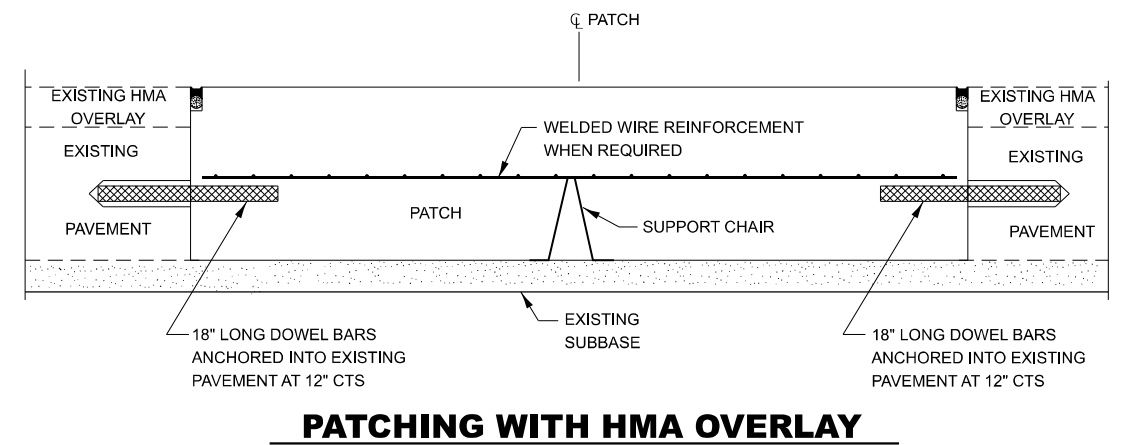
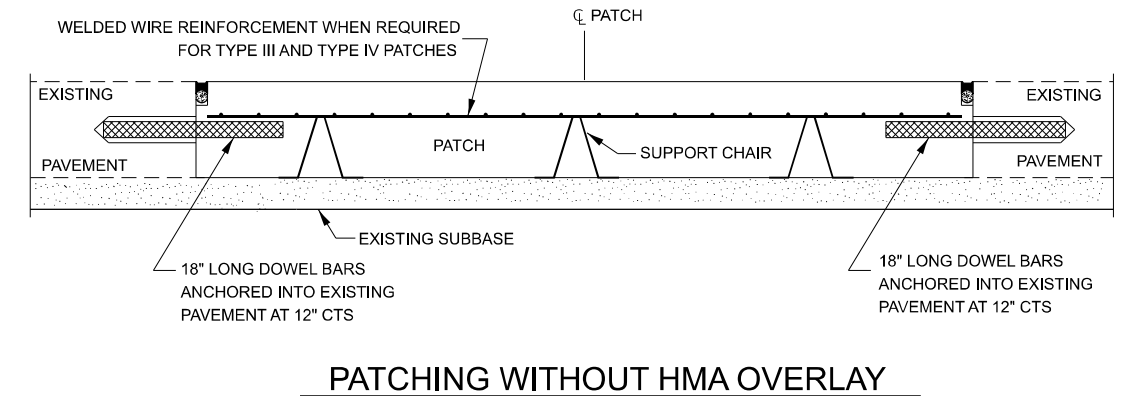
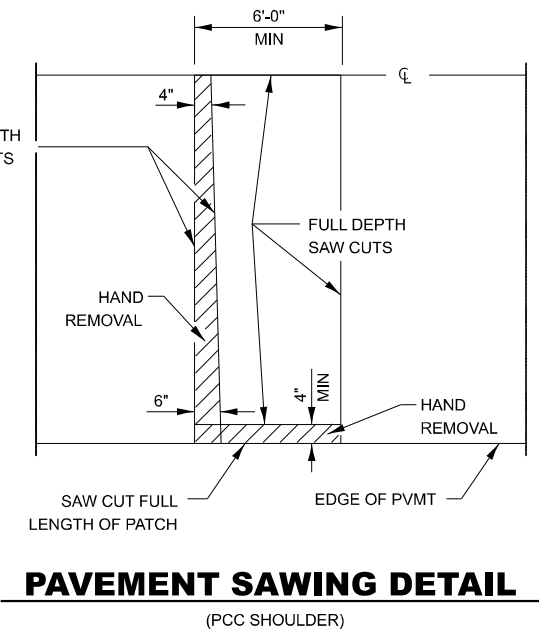
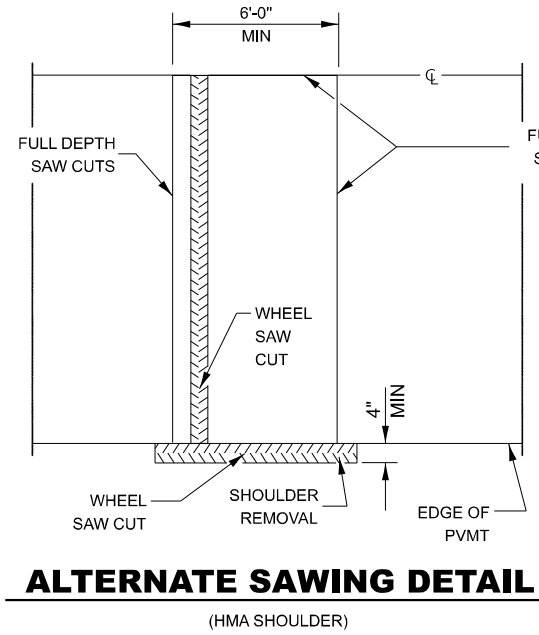
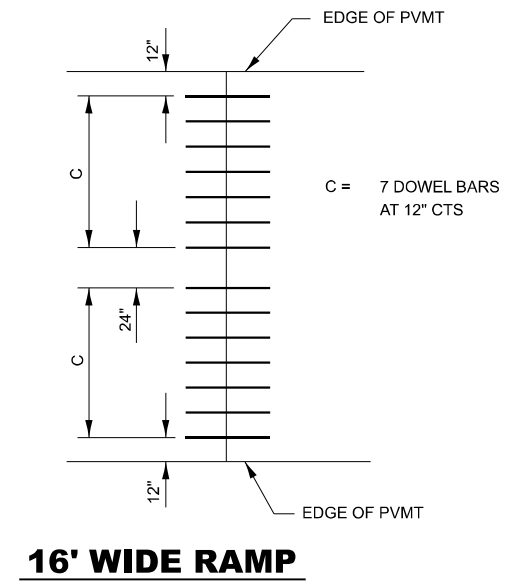
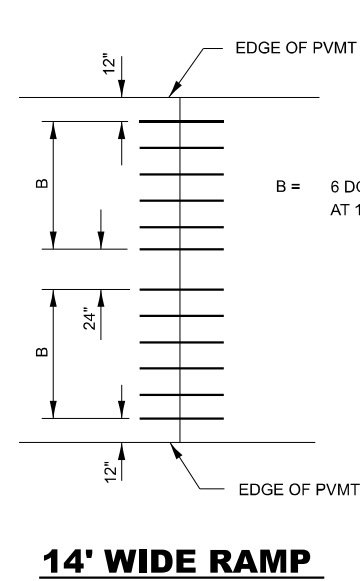
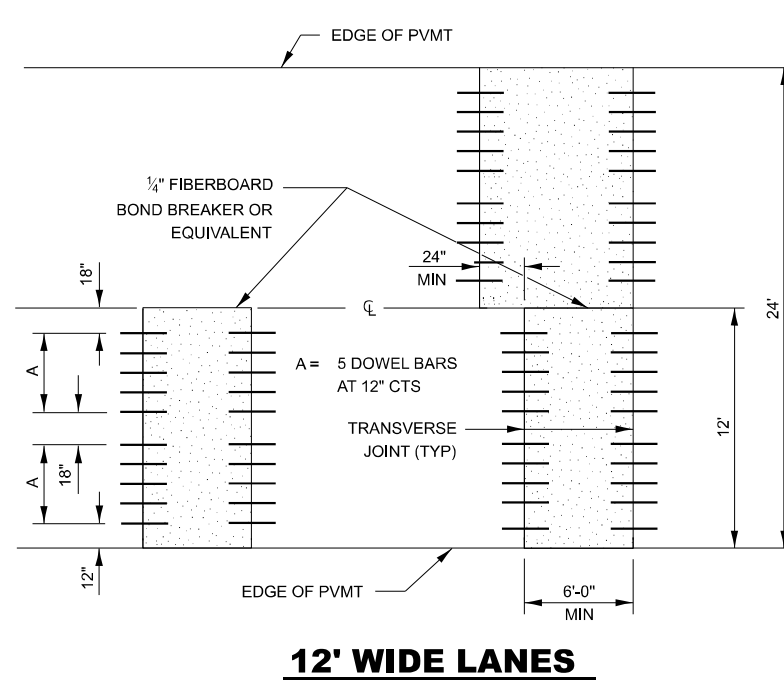
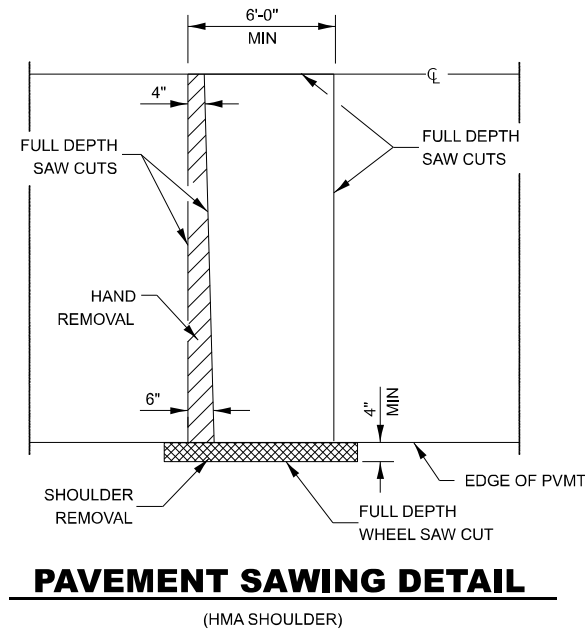

DOWEL BAR TABLE		
PAVEMENT THICKNESS	DOWEL BAR DIAMETER	HOLE DIAMETER
10" OR GREATER	1 1/2"	1 5/8"
8" THRU 9.99"	1 1/4"	1 3/8"
LESS THAN 8"	1"	1 1/8"

GENERAL NOTES

THE TRANSVERSE JOINTS FOR CLASS B PATCHES SHALL ALIGN WITH JOINTS OR CRACKS IN THE ADJACENT LANE WHENEVER POSSIBLE.
SEE STANDARD 420701 FOR DETAILS OF PAVEMENT WELDED WIRE REINFORCEMENT.

MODEL: Default
FILE NAME: c:\pwwork\pwwork\illinois.gov\aladele.co.pppoc\aladele\illinois.gov\d109059696R53.dgn

USER NAME = ronald.woodshank	DESIGNED - RW	REVISED -
	DRAWN - RW	REVISED -
	CHECKED - JS	REVISED -
PLOT DATE = 3/24/2025	DATE - 2/3/2025	REVISED -

STATE OF ILLINOIS
DEPARTMENT OF TRANSPORTATION

CLASS B PATCHING DETAILS

SCALE: SHEET 1 OF 2 SHEETS STA. TO STA.

F.A.P. RTE. 681	SECTION (115,116) PP	COUNTY FORD	TOTAL SHEETS 9	SHEET NO. 7
CONTRACT NO. 66T29				
ILLINOIS FED. AID PROJECT				

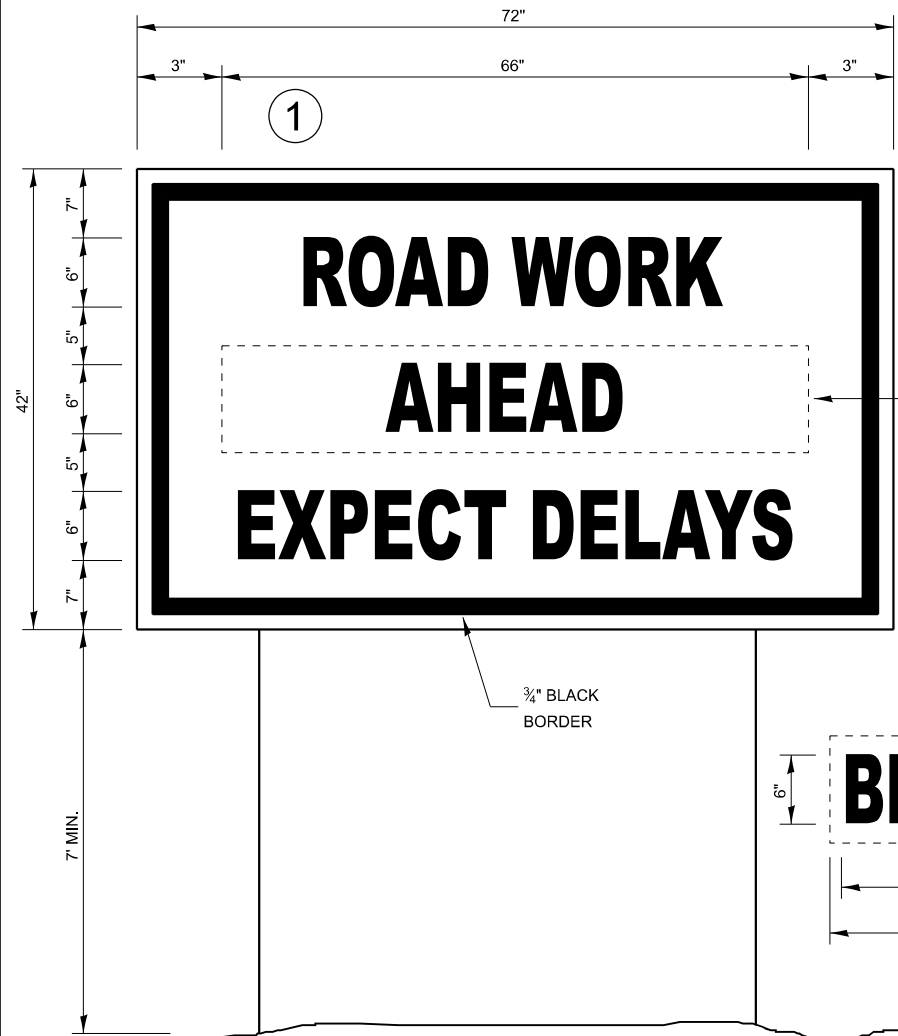

TEMPORARY INFORMATION SIGNING

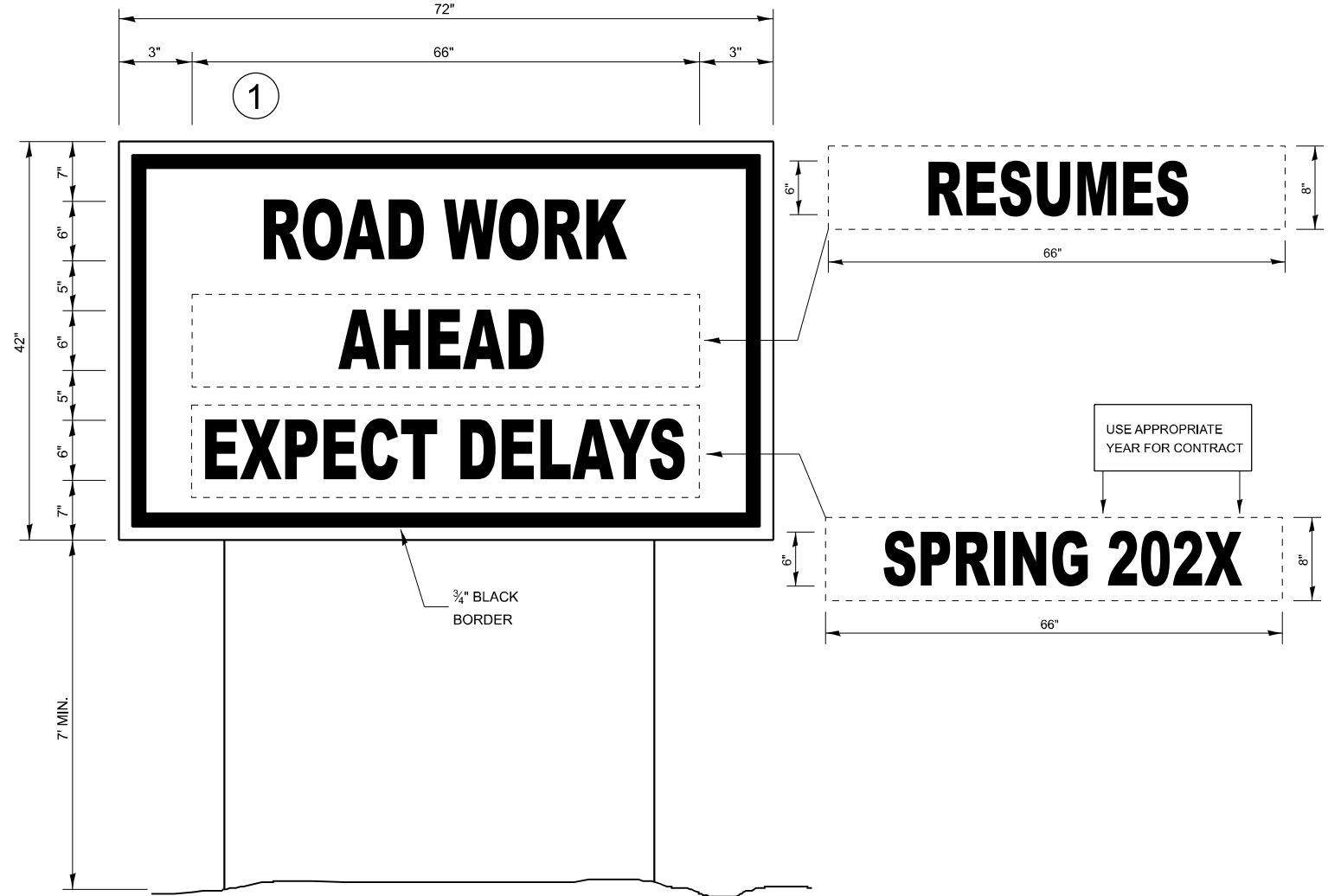

WINTER SHUT DOWN SIGNING

NOTES:

1. USE 6" D BLACK LETTERING ON FLOURESENT ORANGE BACKGROUND.
2. ERECT SIGNS AT LOCATIONS IN ADVANCE OF THE "ROAD CONSTRUCTION AHEAD" SIGNS AS DIRECTED BY THE ENGINEER.
3. ERECT SIGN ① WITH INSTALLED PANEL ② A MINIMUM OF ONE WEEK PRIOR TO THE START OF THE LANE CLOSURE.
4. REMOVE PANEL ② ON THAT DATE.
5. SEE SPECIAL PROVISION "TEMPORARY INFORMATION SIGNING" FOR ADDITIONAL INFORMATION.
6. WILL BE PAID FOR PER SQ FT AS "TEMPORARY INFORMATION SIGNING". EACH SIGN = 21 SQ FT

MODEL: Default
FILE NAME: c:\pwworking\wdot\illinois.gov_dadefale.co.pppocde@illinois.gov\d1090596966PES3.dgn

USER NAME = ronald.woodshank	DESIGNED - RW	REVISED -	STATE OF ILLINOIS DEPARTMENT OF TRANSPORTATION	TEMPORARY INFORMATION SIGNING		F.A.P. RTE. = 681	SECTION = (115,116) PP	COUNTY = FORD	TOTAL SHEETS = 9	SHEET NO. = 9
	DRAWN - RW	REVISED -				CONTRACT NO. 66T29				
CHECKED - JS	REVISED -		SCALE:	SHEET 1 OF 1 SHEETS	STA. TO STA.	ILLINOIS FED. AID PROJECT				
PLOT DATE = 3/24/2025	DATE = 2/3/2025	REVISED -								