

STATE OF ILLINOIS DEPARTMENT OF TRANSPORTATION PROPOSED HIGHWAY PLANS

F.A.I. RTE	SECTION	COUNTY	TOTAL SHEETS	SHEET NO.
72	D7 BRIDGE REPAIRS 2026-3	MACON	108	1
		ILLINOIS	CONTRACT NO. 74D08	

D-97-047-24

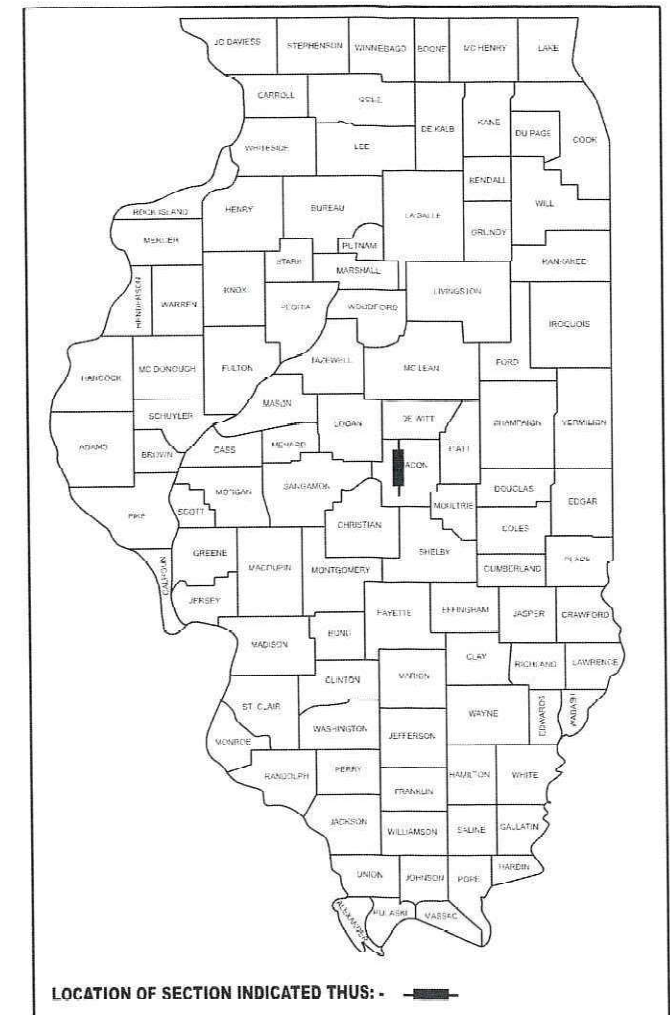

FOR INDEX OF SHEETS, SEE SHEET NO. 2

I-72 ADT = 14,000
I-72 POSTED SPEED LIMIT = 70 MPH

F.A.I. ROUTE 72 (I-72)
SECTION D7 BRIDGE REPAIRS 2026-3
NHPP-A7H9(419)
BRIDGE REPAIR
I-72/US 51 OVER HARRISTOWN BLVD.
I-72/US 51 OVER GRAND AVE. AND NORFOLK SOUTHERN RR
MACON COUNTY
C-97-080-24

R1E, 3RD PM



IL LICENSE NO. 184000883-0006
JOB NO. 1445.01



EXPIRES 11-30-27

SIGNATURE

01-23-26
DATE

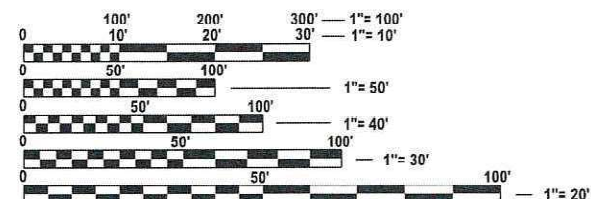

FULL SIZE PLANS HAVE BEEN PREPARED USING STANDARD ENGINEERING SCALES. REDUCED SIZED PLANS WILL NOT CONFORM TO STANDARD SCALES. IN MAKING MEASUREMENTS ON REDUCED PLANS, THE ABOVE SCALES MAY BE USED.

J.U.L.I.E.
JOINT UTILITY LOCATION INFORMATION FOR EXCAVATION
1-800-892-0123
OR 811

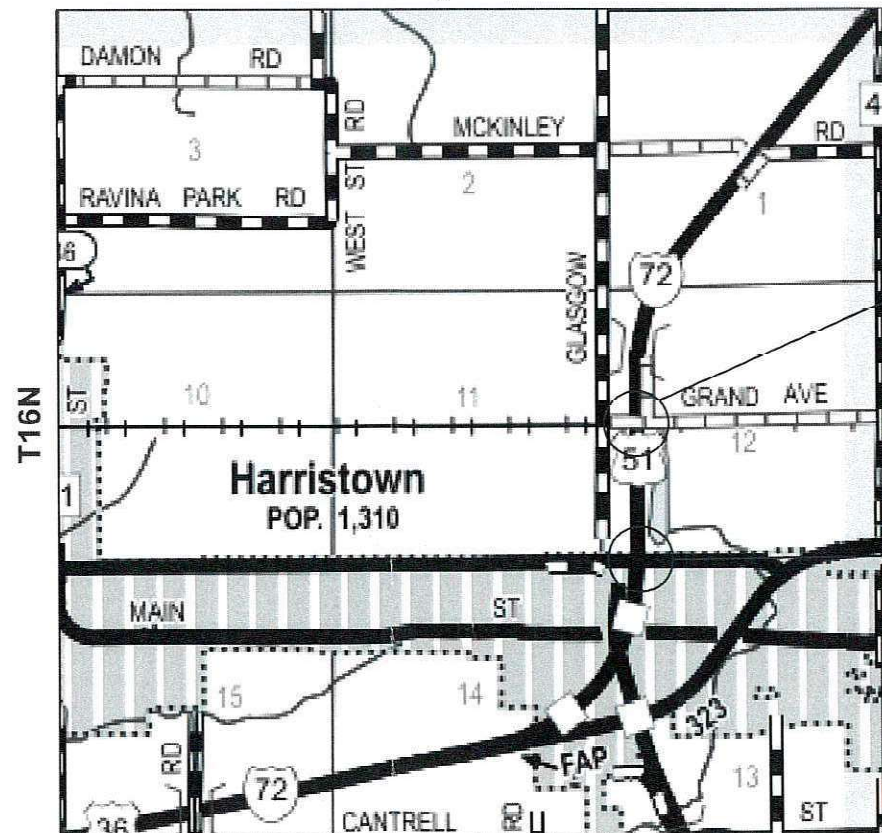

LOCATION MAP

GROSS LENGTH = 3,168 FT. = 0.600 MILE
NET LENGTH = 1,023 FT. = 0.194 MILE

SN 058-0070 & 058-0071
I-72/US 51 OVER GRAND AVENUE AND NORFOLK SOUTHERN RR
TWO-SPAN BRIDGES

SN 058-0068 & 058-0069
I-72/US 51 OVER HARRISTOWN BOULEVARD
TWO-SPAN BRIDGES

STATE OF ILLINOIS
DEPARTMENT OF TRANSPORTATION

SUBMITTED January 28, 20 26

Teresa C. Price
REGIONAL ENGINEER

March 20 20 26
[Signature]
ENGINEER OF DESIGN AND ENVIRONMENT

March 20 20 26
[Signature]
DIRECTOR OF HIGHWAYS PROJECT IMPLEMENTATION

PRINTED BY THE AUTHORITY
OF THE STATE OF ILLINOIS

DISTRICT 7
PROJECT ENGINEER: LEAH HILLE
PROJECT MANAGER: ERIC HENKEL - ESCA CONSULTANTS
TOWNSHIP: HARRISTOWN
CONTRACT NO. 74D08

INDEX OF SHEETS

SHEET NO.	DESCRIPTION
1	COVER SHEET
2	INDEX OF SHEETS, HIGHWAY STANDARDS, AND GENERAL NOTES
3-7	SUMMARY OF QUANTITIES
8	I-72 TYPICAL SECTIONS
9-11	SCHEDULES OF QUANTITIES
12-13	I-72 PAVING PLAN
14-17	I-72 TRAFFIC CONTROL TYPICAL SECTIONS
18-21	I-72 STAGE I TRAFFIC CONTROL PLAN
22-25	I-72 STAGE II TRAFFIC CONTROL PLAN
26-28	HARRISTOWN BOULEVARD STAGE I TRAFFIC CONTROL PLAN
29-31	HARRISTOWN BOULEVARD STAGE II TRAFFIC CONTROL PLAN
32	GRAND AVENUE CLOSURE PLAN
33-36	I-72 PAVEMENT MARKING PLAN
37-38	TYPICAL APPLICATIONS OF INTERSTATE PAVEMENT MARKINGS
39	MISCELLANEOUS DETAILS
40-72	SN 058-0068 & SN 058-0069 STRUCTURE PLANS
73-108	SN 058-0070 & SN 058-0071 STRUCTURE PLANS

GENERAL NOTES

- THIS PROJECT IS LOCATED ON I-72 / US 51 OVER HARRISTOWN BOULEVARD AND GRAND AVENUE IN MACON COUNTY. THIS WORK INCLUDES THE FOLLOWING REPAIRS TO SN 058-0068/0069 CARRYING I-72 / US 51 OVER HARRISTOWN BOULEVARD AND SN 058-0070/0071 CARRYING I-72 / US 51 OVER GRAND AVENUE: DECK PATCHING, NEW CONCRETE WEARING SURFACE, ABUTMENT BEARING REPLACEMENT, EXPANSION JOINT REPLACEMENT, PIER CRASH WALL EXTENSIONS, SLOPE WALL REPAIR, AND OTHER ITEMS SHOWN IN THESE DOCUMENTS.
- PLAN DIMENSIONS AND DETAILS RELATIVE TO EXISTING PLANS ARE SUBJECT TO NOMINAL CONSTRUCTION VARIATIONS. THE CONTRACTOR SHALL FIELD VERIFY EXISTING DIMENSIONS AND DETAILS AFFECTING NEW CONSTRUCTION AND MAKE NECESSARY APPROVED ADJUSTMENTS PRIOR TO CONSTRUCTION OR ORDERING OF MATERIALS. SUCH VARIATIONS SHALL NOT BE CAUSE FOR ADDITIONAL COMPENSATION FOR A CHANGE IN SCOPE OF WORK; HOWEVER, THE CONTRACTOR WILL BE PAID FOR THE QUANTITY ACTUALLY FURNISHED AT THE UNIT PRICE BID FOR THE WORK.
- FOR STABILIZATION, ALL TYPE III BARRICADES SHALL REQUIRE A MINIMUM OF FOUR SANDBAGS PER BARRICADE.
- RUMBLE STRIPS SHALL BE INSTALLED ON ALL SHOULDERS OFF OF THE BRIDGES. HOWEVER, THE STRIPS SHALL NOT BE INSTALLED UNTIL AFTER THE SHOULDER IS NO LONGER NEEDED TO ACCOMMODATE STAGE TRAFFIC.
- THE CONTRACTOR SHALL TAKE ALL MEASURES NECESSARY TO ENSURE THAT THE RWIS WEATHER STATION SHALL BE UNDISTURBED. CONTACT: DOUG RUDOLPHI, D7 MAINTENANCE FIELD ENGINEER, CELL: 217-299-4636
- TEMPORARY CONCRETE BARRIER SHALL BE PINNED ON EACH BRIDGE ACCORDING TO THE DETAILS SHOWN IN THE PLANS. A TRANSITION SHALL BE USED NEAR EACH END OF THE BARRIER INSTALLATION. THE FIRST BARRIER SECTION ON THE ADJACENT ROADWAY SHALL BE PINNED USING TWO PINS. THE SECOND BARRIER SECTION ON THE ADJACENT ROADWAY SHALL BE PINNED USING ONE PIN.
- ANY TEMPORARY RAMPS REQUIRED ARE INCLUDED IN THE COST OF HOT-MIX ASPHALT SURFACE REMOVAL.
- THE COST OF EARTH EXCAVATION AND BACKFILL REQUIRED TO CONSTRUCT NEW PORTLAND CEMENT CONCRETE SHOULDERS IS INCLUDED IN PORTLAND CEMENT CONCRETE BASE COURSE WIDENING 10".
- TRANSVERSE JOINTS SHALL BE CONSTRUCTED IN PORTLAND CEMENT CONCRETE BASE COURSE WIDENING AS SHOWN IN HIGHWAY STANDARD 483001 FOR PCC SHOULDER.
- AGGREGATE SHOULDERS, TYPE B SHALL BE CONSTRUCTED ADJACENT TO PCC BASE COURSE WIDENING AS REQUIRED TO ELIMINATE ANY DROPOFF. COMPACTION SHALL BE TO THE SATISFACTION OF THE ENGINEER. SOME OF THIS QUANTITY MAY BE ELIMINATED AT THE DIRECTION OF THE ENGINEER.

LIST OF ILLINOIS DOT HIGHWAY STANDARDS

STANDARD NO.	DESCRIPTION
000001-09	STANDARDS SYMBOLS, ABBREVIATIONS AND PATTERNS
001001-02	AREAS OF REINFORCEMENT BARS
001006	DECIMAL OF AN INCH AND OF A FOOT
420001-11	PAVEMENT JOINTS
483001-06	PCC SHOULDER
630001-13	STEEL PLATE BEAM GUARDRAIL
642001-03	SHOULDER RUMBLE STRIPS 16"
701001-02	OFF-RD OPERATIONS 2L 2W MORE THAN 15FT
701006-05	OFF-RD OPERATIONS 2L 2W 15' TO 24" FROM PAVEMENT EDGE
701101-05	OFF-RD OPERATIONS, MULTILANE, 15' TO 24" FROM PAVEMENT EDGE
701106-02	OFF-RD OPERATIONS, MULTILANE, MORE THAN 15' AWAY
701400-12	APPROACH TO LANE CLOSURE, FREEWAY/EXPRESSWAY
701401-13	LANE CLOSURE, FREEWAY/EXPRESSWAY
701402-12	LANE CLOSURE FREEWAY/EXPRESSWAY WITH BARRIER
701406-13	LANE CLOSURE FREEWAY/EXPRESSWAY DAY OPERATIONS ONLY
701411-09	LANE CLOSURE MULTILANE ENTRANCE OR EXIT RAMP 45MPH OR MORE
701422-10	LANE CLOSURE MULTILANE 45-55MPH
701426-09	LANE CLOSURE, MULTILANE, INTERMITTENT OR MOVING OPER., FOR SPEEDS \geq 45 MPH
701428-01	TRAFFIC CONTROL SETUP REMOVAL FREEWAY EXPRESSWAY
701446-11	TWO LANE CLOSURE FREEWAY/EXPRESSWAY
701901-11	TRAFFIC CONTROL DEVICES
704001-08	TEMPORARY CONCRETE BARRIER
720001-01	SIGN PANEL MOUNTING DETAILS
720006-04	SIGN PANEL ERECTION DETAILS
780001-05	TYPICAL PAVEMENT MARKINGS
B.L.R. 21-9	TYPICAL APPLICATION OF TRAFFIC CONTROL DEVICES FOR CONSTRUCTION ON RURAL LOCAL HIGHWAYS

APPLICATION RATES

THE FOLLOWING APPLICATION RATES WERE USED IN CALCULATING PLAN QUANTITIES AND HAVE BEEN INCLUDED FOR REFERENCE:	
BITUMINOUS MATERIALS (TACK COAT)	0.05 LB/SQ FT (ON MILLED SURFACES)
	0.025 LB/SQ FT (ON HMA LIFTS)
AGGREGATE	2.05 TON/CU YD

HMA MIXTURES REQUIREMENTS TABLE	
LOCATIONS	FINAL TRAFFIC LANES
MIXTURE USES	HOT-MIX ASPHALT SURFACE COURSE, IL-9.5 MIX "D", N90
PG:	SBS PG 70-28
DESIGN AIR VOIDS:	4.0% @ N90
MIX COMPOSITION:	IL-9.5 mm
FRICTION AGGREGATE:	MIXTURE D
MIXTURE WEIGHT:	112 LB/SQ YD/IN
QUALITY MANAGEMENT PROGRAM:	QC/QA
SUBLOT SIZE:	NA
MATERIAL TRANSFER DEVICE REQUIRED:	NO

STATE OF ILLINOIS DEPARTMENT OF TRANSPORTATION

INDEX OF SHEETS, HIGHWAY STANDARDS, AND GENERAL NOTES

SCALE: NONE SHEET 1 OF 1 SHEETS STA. TO STA.

F.A.I. RTE.	SECTION	COUNTY	TOTAL SHEETS	SHEET NO.
72	D7 BRIDGE REPAIRS 2026-3	MACON	108	2
CONTRACT NO. 74D08				
ILLINOIS FED. AID PROJECT				



USER NAME = rnhc	DESIGNED - ATN	REVISED -
ESCA PROJECT NO. = 1445-01	DRAWN - ATN/NHC	REVISED -
	CHECKED - ELH	REVISED -
PLOT DATE = 9/16/2025	DATE - 01/26	REVISED -

SUMMARY OF QUANTITIES				90% FEDERAL 10% STATE	90% FEDERAL 10% STATE	90% FEDERAL 10% STATE	90% FEDERAL 10% STATE	90% FEDERAL 10% STATE
				ROADWAY	STRUCTURE	STRUCTURE	STRUCTURE	STRUCTURE
CODE NO.	ITEM	UNIT	TOTAL QUANTITY	CONSTRUCTION CODE				
				0006 ROADWAY	0047 SN 058-0068	0047 SN 058-0069	0047 SN 058-0070	0047 SN 058-0071
20201200	REMOVAL AND DISPOSAL OF UNSUITABLE MATERIAL	CU YD	92		15	22	20	35
31101000	SUBBASE GRANULAR MATERIAL, TYPE B	TON	330		30	45	100	155
31101900	SUBBASE GRANULAR MATERIAL, TYPE C	TON	1075	1075				
35400500	PORTLAND CEMENT CONCRETE BASE COURSE WIDENING 10"	SQ YD	9597	9597				
40600290	BITUMINOUS MATERIALS (TACK COAT)	POUND	2209	2209				
40600370	LONGITUDINAL JOINT SEALANT	FOOT	2411	2411				
40604064	HOT-MIX ASPHALT SURFACE COURSE, IL-9.5, MIX "D", N90	TON	481	481				
44000156	HOT-MIX ASPHALT SURFACE REMOVAL, 1 3/4"	SQ YD	4910	4910				
44004250	PAVED SHOULDER REMOVAL	SQ YD	9597	9597				
48101200	AGGREGATE SHOULDERS, TYPE B	TON	318	318				
50102400	CONCRETE REMOVAL	CU YD	61.5		16.2	18.8	13.8	12.7
50104650	SLOPE WALL REMOVAL	SQ YD	896				448	448
50157300	PROTECTIVE SHIELD	SQ YD	1372		542	633	101	96
50300100	FLOOR DRAINS	EACH	36		8	4	12	12

MODEL: Summary Of Quantities Sheet1
 FILE NAME: Y:\IDOT\1445-01_74D08\74D08 DESIGN\CADD\Highway\CADD Sheets\ID774D08-sh1-SQO.dgn



USER NAME = atn	DESIGNED - ATN	REVISED -
ESCA PROJECT NO. = 1445.01	DRAWN - ATN	REVISED -
	CHECKED - ELH	REVISED -
PLOT DATE = 9/23/2025	DATE - 01/26	REVISED -

**STATE OF ILLINOIS
DEPARTMENT OF TRANSPORTATION**

SUMMARY OF QUANTITIES

SCALE: NONE SHEET 1 OF 5 SHEETS STA. TO STA.

F.A.I. RTE.	SECTION	COUNTY	TOTAL SHEETS	SHEET NO.
72	D7 BRIDGE REPAIRS 2026-3	MACON	108	3
CONTRACT NO. 74D08				
ILLINOIS FED. AID PROJECT				

REV - MS

SUMMARY OF QUANTITIES					90% FEDERAL 10% STATE	90% FEDERAL 10% STATE	90% FEDERAL 10% STATE	90% FEDERAL 10% STATE	90% FEDERAL 10% STATE
					ROADWAY	STRUCTURE	STRUCTURE	STRUCTURE	STRUCTURE
CODE NO.	ITEM	UNIT	TOTAL QUANTITY	CONSTRUCTION CODE					
				0006 ROADWAY	0047 SN 058-0068	0047 SN 058-0069	0047 SN 058-0070	0047 SN 058-0071	
50300225	CONCRETE STRUCTURES	CU YD	59.0		7.0	8.7	21.7	21.6	
50300255	CONCRETE SUPERSTRUCTURE	CU YD	60.3		15.7	18.8	13.4	12.4	
50300300	PROTECTIVE COAT	SQ YD	6113		1366	1665	1532	1550	
50500405	FURNISHING AND ERECTING STRUCTURAL STEEL	POUND	13968		3597	4490	2925	2956	
50800205	REINFORCEMENT BARS, EPOXY COATED	POUND	14510		2870	3860	3970	3810	
50800515	BAR SPLICERS	EACH	80		20	20	20	20	
51100100	SLOPE WALL 4 INCH	SQ YD	888				444	444	
52000110	PREFORMED JOINT STRIP SEAL	FOOT	442		114.5	139.5	97	91	
52100010	ELASTOMERIC BEARING ASSEMBLY, TYPE I	EACH	64		16	20	14	14	
52100520	ANCHOR BOLTS, 1"	EACH	112		28	36	24	24	
63300575	REMOVE AND REERECT RAIL ELEMENT OF EXISTING GUARDRAIL	FOOT	1857	1857					
64200116	SHOULDER RUMBLE STRIPS, 16 INCH	FOOT	9554	9554					
67000400	ENGINEER'S FIELD OFFICE, TYPE A	CAL MO	9	9					
67100100	MOBILIZATION	L SUM	1	1					

MODEL: Summary Of Quantities Sheet 2
 FILE NAME: Y:\DOT\1445-01_74D08\74D08 DESIGN\CADD\Highway\CADD Sheets\ID774D08-sh1-SQO.dgn



USER NAME = atn	DESIGNED - ATN	REVISED -
ESCA PROJECT NO. = 1445.01	DRAWN - ATN	REVISED -
	CHECKED - ELH	REVISED -
PLOT DATE = 9/23/2025	DATE - 01/26	REVISED -

STATE OF ILLINOIS
DEPARTMENT OF TRANSPORTATION

SUMMARY OF QUANTITIES

SCALE: NONE SHEET 2 OF 5 SHEETS STA. TO STA.

F.A.I. RTE.	SECTION	COUNTY	TOTAL SHEETS	SHEET NO.
72	D7 BRIDGE REPAIRS 2026-3	MACON	108	4
CONTRACT NO. 74D08				
ILLINOIS FED. AID PROJECT				

REV - MS

MODEL: Summary Of Quantities Sheet 3
 FILE NAME: Y:\DOT\1445-01_74D08\74D08 DESIGN\CADD\Highway\CADD Sheets\ID774D08-ehh-SQO.dgn

SUMMARY OF QUANTITIES				90% FEDERAL 10% STATE	90% FEDERAL 10% STATE	90% FEDERAL 10% STATE	90% FEDERAL 10% STATE	90% FEDERAL 10% STATE
				ROADWAY	STRUCTURE	STRUCTURE	STRUCTURE	STRUCTURE
CODE NO.	ITEM	UNIT	TOTAL QUANTITY	CONSTRUCTION CODE				
				0006 ROADWAY	0047 SN 058-0068	0047 SN 058-0069	0047 SN 058-0070	0047 SN 058-0071
70100205	TRAFFIC CONTROL AND PROTECTION, STANDARD 701401	EACH	2	2				
70100207	TRAFFIC CONTROL AND PROTECTION, STANDARD 701402	EACH	2	2				
70100320	TRAFFIC CONTROL AND PROTECTION, STANDARD 701422	LSUM	1	1				
70100420	TRAFFIC CONTROL AND PROTECTION, STANDARD 701411	EACH	2	2				
70100430	TRAFFIC CONTROL AND PROTECTION, STANDARD 701446	EACH	2	2				
70100700	TRAFFIC CONTROL AND PROTECTION, STANDARD 701406	LSUM	1	1				
70107007	PAVEMENT MARKING BLACKOUT TAPE, 7"	FOOT	12913	12913				
70107009	PAVEMENT MARKING BLACKOUT TAPE, 9"	FOOT	1941	1941				
70107025	CHANGEABLE MESSAGE SIGN	CAL DA	70	70				
70300100	SHORT TERM PAVEMENT MARKING	FOOT	440	440				
70300150	SHORT TERM PAVEMENT MARKING REMOVAL	SQ FT	9136	9136				
70300241	TEMPORARY PAVEMENT MARKING - LINE 6"- PAINT	FOOT	4984	4984				
70400100	TEMPORARY CONCRETE BARRIER	FOOT	2175	2175				
70400125	PINNING TEMPORARY CONCRETE BARRIER	EACH	48	48				

REV - MS



USER NAME = atn	DESIGNED - ATN	REVISED -
ESCA PROJECT NO. = 1445.01	DRAWN - ATN	REVISED -
	CHECKED - ELH	REVISED -
PLOT DATE = 9/23/2025	DATE - 01/26	REVISED -

STATE OF ILLINOIS
 DEPARTMENT OF TRANSPORTATION

SUMMARY OF QUANTITIES

SCALE: NONE SHEET 3 OF 5 SHEETS STA. TO STA.

F.A.I. RTE.	SECTION	COUNTY	TOTAL SHEETS	SHEET NO.
72	D7 BRIDGE REPAIRS 2026-3	MACON	108	5
CONTRACT NO. 74D08				
ILLINOIS FED. AID PROJECT				

SUMMARY OF QUANTITIES				90% FEDERAL 10% STATE	90% FEDERAL 10% STATE	90% FEDERAL 10% STATE	90% FEDERAL 10% STATE	90% FEDERAL 10% STATE
				ROADWAY	STRUCTURE	STRUCTURE	STRUCTURE	STRUCTURE
CODE NO.	ITEM	UNIT	TOTAL QUANTITY	CONSTRUCTION CODE				
				0006 ROADWAY	0047 SN 058-0068	0047 SN 058-0069	0047 SN 058-0070	0047 SN 058-0071
70400200	RELOCATE TEMPORARY CONCRETE BARRIER	FOOT	2125	2125				
70600250	IMPACT ATTENUATORS, TEMPORARY (NON- REDIRECTIVE), TEST LEVEL 3	EACH	4	4				
70600350	IMPACT ATTENUATORS, RELOCATE (NON- REDIRECTIVE), TEST LEVEL 3	EACH	4	4				
78004600	PREFORMED PLASTIC PAVEMENT MARKING, TYPE D - STANDARD - LETTERS AND SYMBOLS	SQ FT	44	44				
* 78004630	PREFORMED PLASTIC PAVEMENT MARKING, TYPE D - STANDARD - LINE 6"	FOOT	4984	4984				
* 78011000	GROOVING FOR RECESSED PAVEMENT MARKING, LETTERS AND SYMBOLS	SQ FT	44	44				
* 78011035	GROOVING FOR RECESSED PAVEMENT MARKING 7"	FOOT	4984	4984				
78300202	PAVEMENT MARKING REMOVAL - WATER BLASTING	SQ FT	2492	2492				
X5030250	BRIDGE DECK GROOVING (LONGITUDINAL)	SQ YD	3415		851	1144	742	678
X5110310	SLOPE WALL REPAIR	SQ YD	228		66	82		80
X5110312	SLOPE WALL SLURRY PUMPING	CU YD	75		20	5	37	13
X5537800	STORM SEWERS TO BE CLEANED 12"	FOOT	582	582				
X7011800	TRAFFIC CONTROL AND PROTECTION, STANDARD BLR 21	L SUM	1	1				
Z0001899	JACK AND REMOVE EXISTING BEARINGS	EACH	64		16	20	14	14

* SPECIALTY ITEM

REV - MS

MODEL: Summary Of Quantities Sheet 4
FILE NAME: Y:\DOT\1445-01_74D08\74D08 DESIGN\CADD\Highway\CADD Sheets\ID774D08-sh1-SQO.dgn



USER NAME = atn	DESIGNED - ATN	REVISED -
ESCA PROJECT NO. = 1445.01	DRAWN - ATN	REVISED -
	CHECKED - ELH	REVISED -
PLOT DATE = 1/16/2026	DATE - 01/26	REVISED -

STATE OF ILLINOIS
DEPARTMENT OF TRANSPORTATION

SUMMARY OF QUANTITIES

SCALE: NONE SHEET 4 OF 5 SHEETS STA. TO STA.

F.A.I. RTE.	SECTION	COUNTY	TOTAL SHEETS	SHEET NO.
72	D7 BRIDGE REPAIRS 2026-3	MACON	108	6
CONTRACT NO. 74D08				
ILLINOIS FED. AID PROJECT				

MODEL: Summary Of Quantities Sheet 5
 FILE NAME: Y:\DOT\1445-01_74D08\74D08 DESIGN\CADD\Highway\CADD Sheets\ID774D08-8ht-SQO.dgn

SUMMARY OF QUANTITIES				90% FEDERAL 10% STATE	90% FEDERAL 10% STATE	90% FEDERAL 10% STATE	90% FEDERAL 10% STATE	90% FEDERAL 10% STATE
				ROADWAY	STRUCTURE	STRUCTURE	STRUCTURE	STRUCTURE
CODE NO.	ITEM	UNIT	TOTAL QUANTITY	CONSTRUCTION CODE				
				0006 ROADWAY	0047 SN 058-0068	0047 SN 058-0069	0047 SN 058-0070	0047 SN 058-0071
Z0007101	CONTAINMENT AND DISPOSAL OF LEAD PAINT CLEANING RESIDUES NO. 1	L SUM	1				1	
Z0007102	CONTAINMENT AND DISPOSAL OF LEAD PAINT CLEANING RESIDUES NO. 2	L SUM	1					1
Z0010501	CLEANING AND PAINTING STEEL BRIDGE NO. 1	L SUM	1				1	
Z0010502	CLEANING AND PAINTING STEEL BRIDGE NO. 2	L SUM	1					1
Z0010615	CLEANING EXISTING INLETS	EACH	16	16				
53101209	BRIDGE DECK FLY ASH OR GGBF SLAG CONCRETE OVERLAY, 2 1/2"	SQ YD	4789		1244	1519	1043	983
53101008	BRIDGE DECK SCARIFICATION 2 1/4"	SQ YD	4789		1244	1519	1043	983
53212754	STRUCTURAL REPAIR OF CONCRETE (DEPTH EQUAL TO OR LESS THAN 5 INCHES)	SQ FT	949.8		274.9	263.9	197	214
53016001	DECK SLAB REPAIR (FULL DEPTH, TYPE I)	SQ YD	54		10	11	14	19
53016002	DECK SLAB REPAIR (FULL DEPTH, TYPE II)	SQ YD	361		65	145	89	62
Z0021700	EXPANSION JOINT REHABILITATION	FOOT	599	599				
Z0029090	DIAMOND GRINDING (BRIDGE SECTION)	SQ YD	4586		1194	1482	987	923
Z0048665	RAILROAD PROTECTIVE LIABILITY INSURANCE	L SUM	1	1				

REV - MS



USER NAME = atn	DESIGNED - ATN	REVISED -
ESCA PROJECT NO. = 1445.01	DRAWN - ATN	REVISED -
	CHECKED - ELH	REVISED -
PLOT DATE = 1/16/2026	DATE - 01/26	REVISED -

STATE OF ILLINOIS
 DEPARTMENT OF TRANSPORTATION

SUMMARY OF QUANTITIES

SCALE: NONE SHEET 5 OF 5 SHEETS STA. TO STA.

F.A.I. RTE.	SECTION	COUNTY	TOTAL SHEETS	SHEET NO.
72	D7 BRIDGE REPAIRS 2026-3	MACON	108	7
CONTRACT NO. 74D08				
ILLINOIS FED. AID PROJECT				

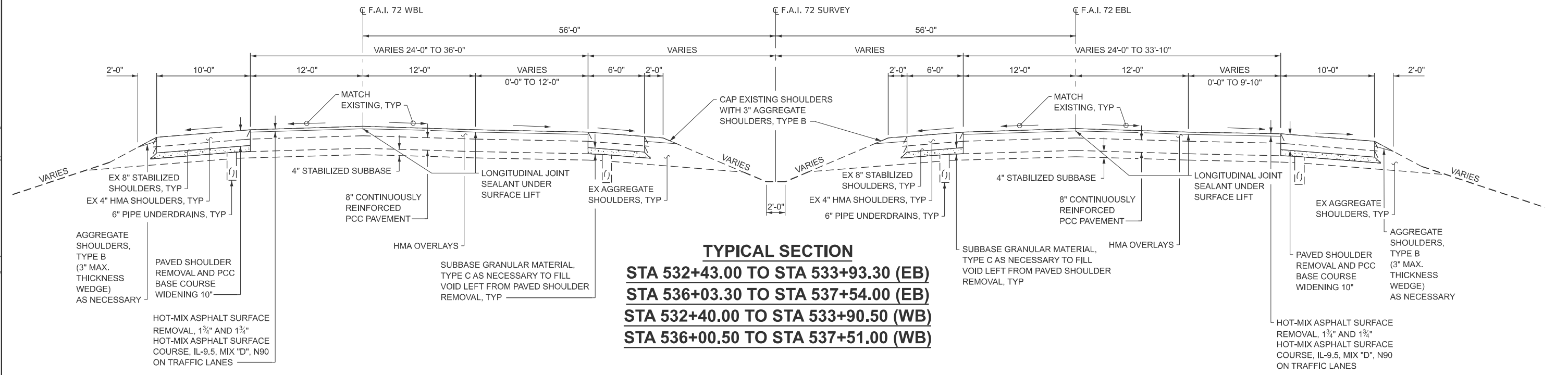
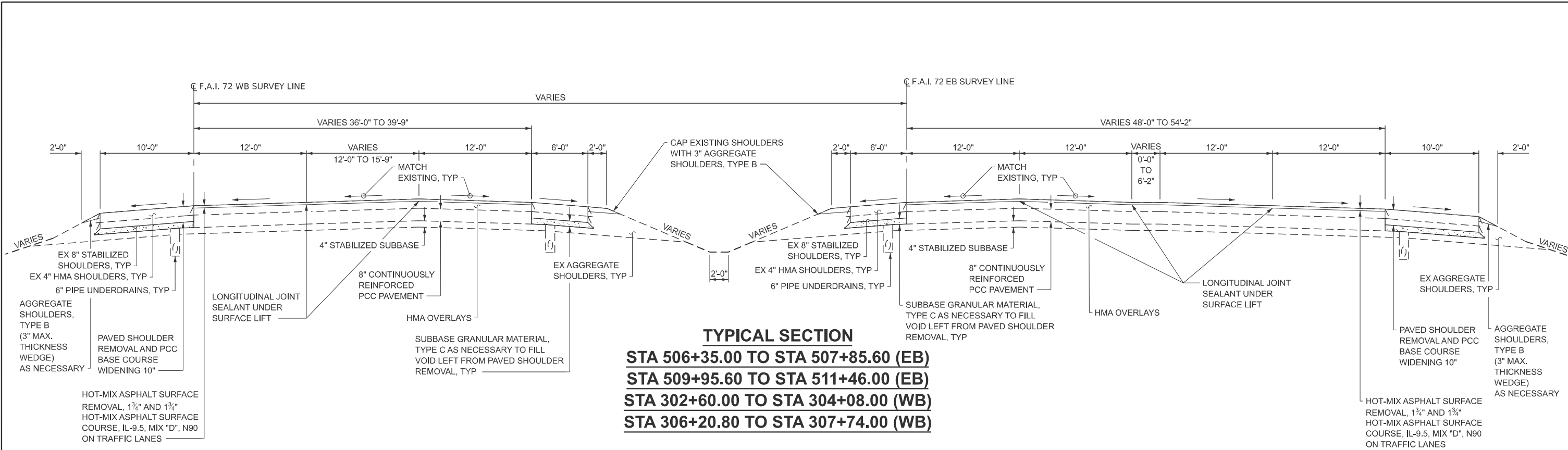

- NOTES:
 1. EXISTING GUARDRAIL NOT SHOWN.
 2. STATIONING IS BASED ON OLD PLANS.

MODEL - Existing Typical Sheet
 FILE NAME - Y:\DOT\11445-01_74D08\74D08_DESIGN\CADD\Highway\CADD Sheets\174D08-shs-tyr-pc-a01.dgn



USER NAME = rnhc	DESIGNED - ATN	REVISED -
ESCA PROJECT NO. = 1445,01	DRAWN - ATN/NHC	REVISED -
PLOT DATE = 9/17/2025	CHECKED - ELH	REVISED -
	DATE - 01/26	REVISED -

STATE OF ILLINOIS
 DEPARTMENT OF TRANSPORTATION

SCALE: NONE		SHEET 1 OF 1 SHEETS		STA.	TO STA.
		I-72 TYPICAL SECTIONS			

F.A.I. RTE.	SECTION	COUNTY	TOTAL SHEETS	SHEET NO.
72	D7 BRIDGE REPAIRS 2026-3	MACON	108	8
CONTRACT NO. 74D08				
ILLINOIS FED. AID PROJECT				

DRAINAGE SCHEDULE		
LOCATION	CLEANING EXISTING INLETS	STORM SEWERS TO BE CLEANED 12"
	EACH	FOOT
SN 058-0068		
CENTER OF BRIDGE		50
SOUTHWEST QUADRANT	2	2
SOUTHEAST QUADRANT	2	86
SN 058-0069		
CENTER OF BRIDGE		66
SOUTHWEST QUADRANT	2	2
SOUTHEAST QUADRANT	2	84
SN 058-0070		
CENTER OF BRIDGE		40
NORTHWEST QUADRANT	2	101
NORTHEAST QUADRANT	2	2
SN 058-0071		
CENTER OF BRIDGE		40
NORTHWEST QUADRANT	2	2
NORTHEAST QUADRANT	2	107
TOTALS	16	582

GUARDRAIL SCHEDULE	
LOCATION	REMOVE AND REERECT RAIL ELEMENT OF EXISTING GUARDRAIL
	FOOT
SN 058-0068	
NORTHWEST QUADRANT	272
NORTHEAST QUADRANT	162
SN 058-0069	
SOUTHWEST QUADRANT	247
SOUTHEAST QUADRANT	248
SN 058-0070	
NORTHWEST QUADRANT	272
NORTHEAST QUADRANT	247
SN 058-0071	
SOUTHWEST QUADRANT	247
SOUTHEAST QUADRANT	162
TOTAL	1857

STAGE CONSTRUCTION SCHEDULE					
LOCATION	TEMPORARY CONCRETE BARRIER	RELOCATE TEMPORARY CONCRETE BARRIER	PINNING TEMPORARY CONCRETE BARRIER	IMPACT ATTENUATORS, TEMPORARY (NON-REDIRECTIVE), TEST LEVEL 3	IMPACT ATTENUATORS, RELOCATE (NON-REDIRECTIVE), TEST LEVEL 3
	FOOT	FOOT	EACH	EACH	EACH
EASTBOUND					
STAGE I (SN 058-0069)	600		6	1	
STAGE I (SN 058-0071)	500		6	1	
STAGE II (SN 058-0069)		637.5	6		1
STAGE II (SN 058-0071)		525	6		1
WESTBOUND					
STAGE I (SN 058-0068)	550		6	1	
STAGE I (SN 058-0070)	525		6	1	
STAGE II (SN 058-0068)		512.5	6		1
STAGE II (SN 058-0070)		450	6		1
TOTALS	2175	2125	48	4	4

PAVING SCHEDULE					
LOCATION	HOT-MIX ASPHALT SURFACE REMOVAL, 1 3/4"	HOT-MIX ASPHALT, IL -9.5, MIX "D", N90	BITUMINOUS MATERIALS (TACK COAT)	LONGITUDINAL JOINT SEALANT	EXPANSION JOINT REHABILITATION
	SQ YD	TON	POUND	FOOT	FOOT
SN 058-0068					
SOUTH SIDE AREA	639	63	287	296	79
NORTH SIDE AREA	604	59	272	306	74
SN 058-0069					
SOUTH SIDE AREA	873	85	393	452	109
NORTH SIDE AREA	762	75	343	451	90
SN 058-0070					
SOUTH SIDE AREA	583	57	262	301	72
NORTH SIDE AREA	477	47	215	151	57
SN 058-0071					
SOUTH SIDE AREA	545	53	245	303	68
NORTH SIDE AREA	427	42	192	151	50
TOTALS	4910	481	2209	2411	599

SHOULDER SCHEDULE					
LOCATION	PORTLAND CEMENT CONCRETE BASE COURSE WIDENING 10"	PAVED SHOULDER REMOVAL	SHOULDER RUMBLE STRIPS, 16"	SUBBASE GRANULAR MATERIAL, TYPE C	AGGREGATE SHOULDERS, TYPE B
	SQ YD	SQ YD	FOOT	TON	TON
STAGE I					
EASTBOUND					
STA 494+10 TO STA 502+90, RT	1115	1115	890	114	17
STA 502+90 TO STA 506+49, RT	466	466		53	
STA 794+25 TO STA 798+99, RT	333	333		38	
STA 504+67 TO STA 507+80, RT	335	335	309	39	6
STA 509+98 TO STA 522+00, RT	1370	1370	1203	153	23
STA 532+43 TO STA 533+93, RT	178	178	150	19	3
STA 536+16 TO STA 542+54, RT	790	790	638	81	12
WESTBOUND					
STA 302+60 TO STA 303+94, LT	147	147	134	17	3
STA 306+20 TO STA 310+79, LT	511	511	460	59	9
STA 528+90 TO STA 533+90, LT	556	556	501	64	10
STA 536+14 TO STA 542+51, LT	707	707	637	81	12
STAGE II					
EASTBOUND					
STA 789+56 TO STA 802+88, LT	887	887	1330	102	64
STA 499+00 TO STA 507+72, LT	581	581	871	67	42
STA 509+97 TO STA 515+38, LT	362	362	543	42	26
STA 529+00 TO STA 533+93, RT	328	328	492	38	24
STA 536+16 TO STA 540+94, RT	318	318	478	37	23
WESTBOUND					
STA 302+60 TO STA 304+01, RT	94	94	141	11	7
STA 306+27 TO STA 307+74, RT	98	98	147	11	7
STA 532+40 TO STA 533+90, LT	101	101	150	12	7
STA 536+14 TO STA 540+94, LT	320	320	480	37	23
TOTALS	9597	9597	9554	1075	318

MODEL: SCHEDULE SHEET 1
FILE NAME: Y:\DOT11445-01_74D08\74D08_DESIGN\CADD\Highway\CADD Sheets\ID774D08-shs-schedule01.dgn



USER NAME = atn	DESIGNED - ATN	REVISED -
ESCA PROJECT NO. = 1445.01	DRAWN - ATN	REVISED -
	CHECKED - ELH	REVISED -
PLOT DATE = 9/16/2025	DATE - 01/26	REVISED -

**STATE OF ILLINOIS
DEPARTMENT OF TRANSPORTATION**

SCHEDULES OF QUANTITIES

SCALE: NONE SHEET 1 OF 3 SHEETS STA. TO STA.

F.A.I. RTE.	SECTION	COUNTY	TOTAL SHEETS	SHEET NO.
72	D7 BRIDGE REPAIRS 2026-3	MACON	108	9
CONTRACT NO. 74D08				
ILLINOIS FED. AID PROJECT				

PAVEMENT MARKING SCHEDULE

LOCATION	DESCRIPTION	PREFORMED PLASTIC PAVEMENT MARKING, TYPE - D - STANDARD - LINE 6"		TEMPORARY PAVEMENT MARKING - LINE 6" - PAINT		PAVEMENT MARKING REMOVAL - WATER BLASTING	SHORT TERM PAVEMENT MARKING		SHORT TERM PAVEMENT MARKING REMOVAL	GROOVING FOR RECESSED PAVEMENT MARKING 7"		
		FOOT		FOOT			SQ FT				FOOT	
		YELLOW	WHITE	YELLOW	WHITE		YELLOW	WHITE			YELLOW	WHITE
EASTBOUND												
STA 506+35.00, 0.00' TO STA 511+46.00, 0.00'	EDGE LINE	511		511		255	12		4.0	511		
STA 506+35.00, 55.33' RT TO STA 511+46.00, 44.05' RT	EDGE LINE		511		511	256		12	4.0	511		
STA 506+35.00, 24.00' RT TO STA 506+49.02, 24.00' RT	EDGE LINE		14		14	7				14		
STA 506+35.00, 26.00' RT TO STA 506+49.02, 26.00' RT	EDGE LINE		14		14	7				14		
STA 506+49.02, 24.00' RT TO STA 506+49.02, 26.00' RT	EDGE LINE		2		2	1				2		
STA 532+43.00, 44.00' RT TO STA 537+54.00, 44.00' RT	EDGE LINE	511		511		255	12		4.0	511		
STA 532+43.00, 78.12' RT TO STA 537+54.00, 68.00' RT	EDGE LINE		511		511	256		12	4.0	511		
STA 506+35.00, 12.00' RT TO STA 511+46.00, 12.00' RT	CENTER LINE SKIP DASH		130		130	65		52	17.4	130		
STA 506+49.02, 24.00' RT TO STA 511+46.00, 24.00' RT	CENTER LINE SKIP DASH		130		130	65		52	17.4	130		
STA 532+43.00, 56.00' RT TO STA 537+54.00, 56.00' RT	CENTER LINE SKIP DASH		130		130	65		52	17.4	130		
STA 532+43.00, 68.25' RT TO STA 533+93.30, 68.00' RT	CENTER LINE SKIP DASH		40		40	20		16	5.3	40		
WESTBOUND												
STA 302+60.00, 0.00' TO STA 307+74.00, 0.00'	EDGE LINE	514		514		257	12		4.0	514		
STA 302+60.00, 40.00' RT TO STA 307+74.00, 36.13' RT	EDGE LINE		514		514	257		12	4.0	514		
STA 532+40.00, 32.00' LT TO STA 537+51.00, 40.17' LT	EDGE LINE		511		511	255		12	4.0	511		
STA 532+40.00, 68.00' LT TO STA 537+51.00, 68.00' LT	EDGE LINE	511		511		256	12		4.0	511		
STA 302+60.00, 12.00' RT TO STA 307+74.00, 12.00' RT	CENTER LINE SKIP DASH		130		130	65		52	17.4	130		
STA 302+60.00, 27.71' RT TO STA 307+74.00, 25.38' RT	CENTER LINE SKIP DASH		130		130	65		52	17.4	130		
STA 532+40.00, 44.00' LT TO STA 533+90.50, 43.81' LT	CENTER LINE SKIP DASH		40		40	20		16	5.3	40		
STA 532+40.00, 56.00' LT TO STA 537+51.00, 56.03' LT	CENTER LINE SKIP DASH		130		130	65		52	17.4	130		
	SUBTOTALS	2047	2937	2047	2937			48	392			
	TOTALS	4984		4984		2492		440	147.0	4984		

PAVEMENT MARKING BLACKOUT TAPE SCHEDULE

LOCATION	DESCRIPTION	PAVEMENT MARKING BLACKOUT TAPE, 7"	PAVEMENT MARKING BLACKOUT TAPE, 9"	SHORT TERM PAVEMENT MARKING REMOVAL
		FOOT	FOOT	SQ FT
STAGE I				
EASTBOUND				
STA 483+60.10 TO STA 495+12.70	CENTER LINE SKIP DASH	290		169.2
STA 494+10.29 TO STA 500+62.98	EDGE LINE	657		383.3
STA 503+53.91 TO STA 506+48.64	EDGE LINE		362	271.5
STA 503+63.92	EX MERGE ARROW	50		29.2
STA 794+25.23 TO STA 798+99.07	EDGE LINE		475	356.3
STA 795+73.33 TO STA 798+99.07	EDGE LINE		326	244.5
STA 795+85.00 TO STA 803+74.31	CENTERLINE	200		116.7
STA 798+99.07 TO STA 806+36.08	RAMP STRIPING SKIP DASH	246		143.5
STA 504+66.87 TO STA 522+00.00	EDGE LINE	1754		1023.2
STA 527+42.77 TO STA 533+92.76	CENTER LINE SKIP DASH	160		93.3
STA 527+42.77 TO STA 542+53.57	EDGE LINE	1511		881.4
WESTBOUND				
STA 302+60.00 TO STA 310+79.33	EDGE LINE	819		477.8
STA 528+90.28 TO STA 542+50.98	EDGE LINE	1362		794.5
STA 541+50.84 TO STA 545+99.48	CENTER LINE SKIP DASH	110		64.2
STAGE II				
EASTBOUND				
STA 491+95.75 TO STA 499+61.62	CENTER LINE SKIP DASH	200		116.7
STA 499+00.00 TO STA 507+85.45	EDGE LINE	885		516.3
STA 788+65.97 TO STA 795+85.00	CENTERLINE	180		105.0
STA 789+56.46 TO STA 805+40.38	EDGE LINE	1584		924.0
STA 504+51.08 TO STA 506+75.47	EDGE LINE		225	168.8
STA 794+61.82 TO STA 797+69.01	EDGE LINE		306	229.5
STA 795+77.10 TO STA 798+22.68	EDGE LINE		247	185.3
STA 506+49.82 TO STA 507+85.45	CENTER LINE SKIP DASH	30		17.5
STA 509+95.87 TO STA 515+38.36	EDGE LINE	543		316.8
STA 509+95.87 TO STA 522+18.36	CENTER LINE SKIP DASH	310		180.8
STA 529+00.00 TO STA 533+92.76	EDGE LINE	492		287.0
STA 536+03.76 TO STA 540+93.76	EDGE LINE	490		285.8
WESTBOUND				
STA 303+61.84 TO STA 304+11.66	CENTER LINE SKIP DASH	10		5.9
STA 306+25.23 TO STA 533+90.00	CENTER LINE SKIP DASH	600		350.0
STA 538+04.10 TO STA 540+93.76	EDGE LINE	290		169.2
STA 541+51.08 TO STA 546+94.50	CENTER LINE SKIP DASH	140		81.8
	TOTALS	12913	1941	8989.0

MODEL: SCHEDULE SHEET 3
FILE NAME: Y:\DOT11445-01_74D08\74D08_DESIGN\CADD\Highway\CADD Sheets\ID774D08-sht-schedule01.dgn



USER NAME = atn	DESIGNED - ATN	REVISED -
ESCA PROJECT NO. = 1445.01	DRAWN - ATN	REVISED -
	CHECKED - ELH	REVISED -
PLOT DATE = 9/23/2025	DATE - 01/26	REVISED -

**STATE OF ILLINOIS
DEPARTMENT OF TRANSPORTATION**

SCHEDULES OF QUANTITIES

SCALE: NONE SHEET 3 OF 3 SHEETS STA. TO STA.

F.A.I. RTE.	SECTION	COUNTY	TOTAL SHEETS	SHEET NO.
72	D7 BRIDGE REPAIRS 2026-3	MACON	108	11
CONTRACT NO. 74D08				
		ILLINOIS	FED. AID PROJECT	

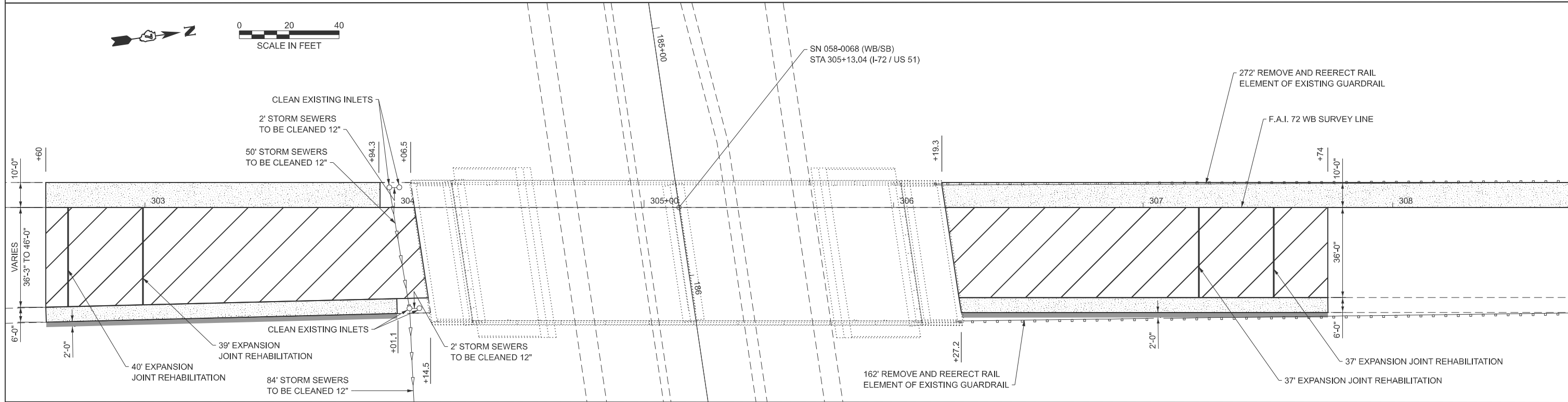

LEGEND

- PAVED SHOULDER REMOVAL & PORTLAND CEMENT CONCRETE BASE COURSE WIDENING, 10" SEE TRAFFIC CONTROL PLANS FOR LIMITS
- HOT-MIX ASPHALT SURFACE REMOVAL, 1 3/4" & 1 1/2" HOT-MIX ASPHALT SURFACE COURSE, IL-9.5, MIX "D", N90
- AGGREGATE SHOULDERS, TYPE B

SN 058-0068 PAVING PLAN

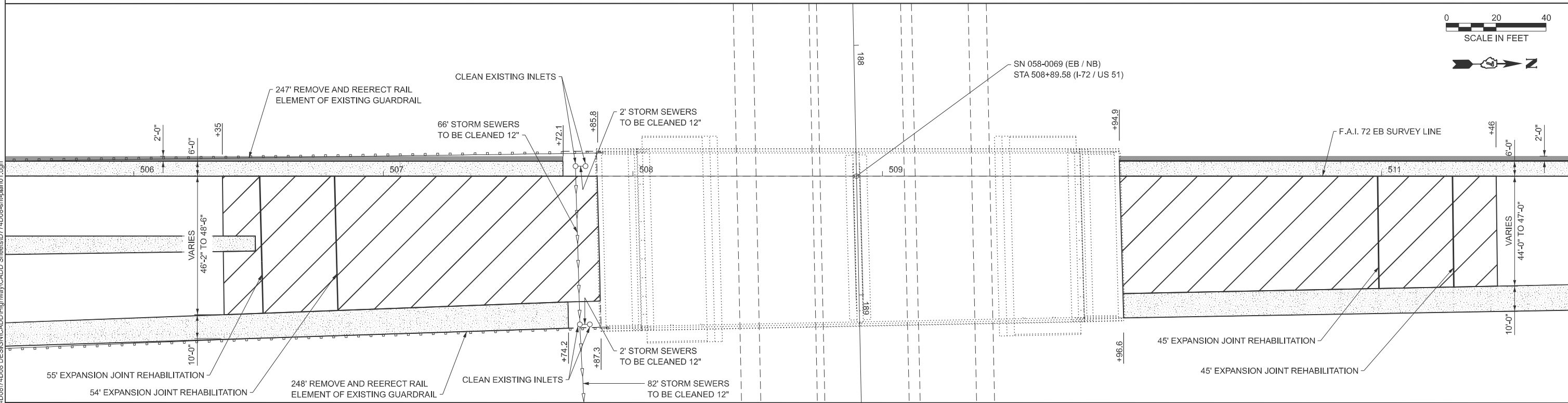

SN 058-0069 PAVING PLAN

MODEL: Paving Plan Sheet 1
 FILE NAME: Y:\DOT11445-01_74D08\74D08_DESIGN\CADD\Highway\CADD Sheets\74D08-shp-plan01.dgn



USER NAME = atn	DESIGNED - ATN	REVISED -
ESCA PROJECT NO. = 1445.01	DRAWN - ATN/NHC	REVISED -
	CHECKED - ELH	REVISED -
PLOT DATE = 1/16/2026	DATE - 01/26	REVISED -

**STATE OF ILLINOIS
DEPARTMENT OF TRANSPORTATION**

I-72 PAVING PLAN	
SCALE: 1" = 50'	SHEET 1 OF 2 SHEETS
STA.	TO STA.

F.A.I. RTE.	SECTION	COUNTY	TOTAL SHEETS	SHEET NO.
72	D7 BRIDGE REPAIRS 2026-3	MACON	108	12
CONTRACT NO. 74D08				
ILLINOIS FED. AID PROJECT				

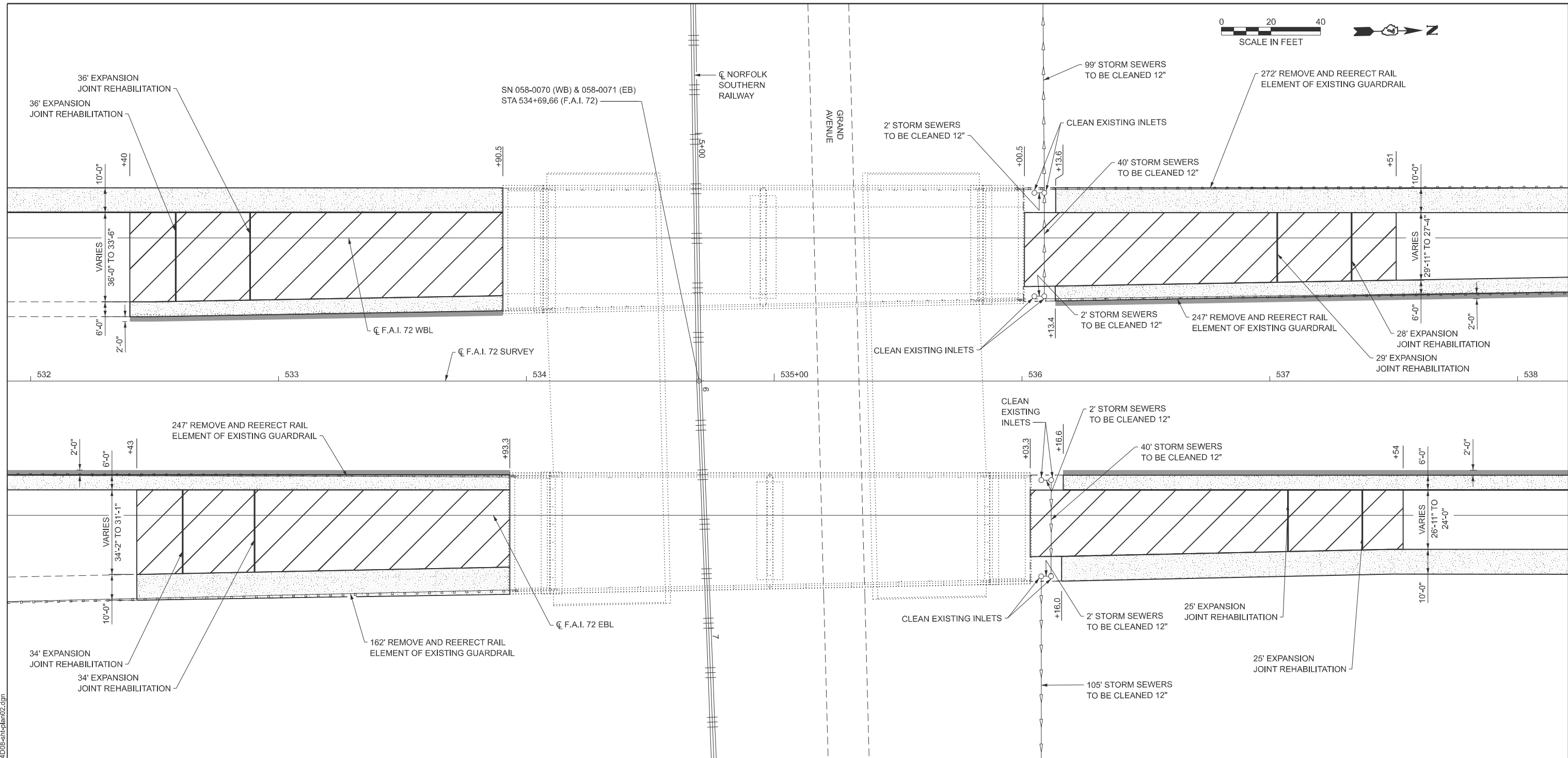

**SN 058-0070 & SN 058-0071
PAVING PLAN**

LEGEND

- PAVED SHOULDER REMOVAL & PORTLAND CEMENT CONCRETE BASE COURSE WIDENING, 10" SEE TRAFFIC CONTROL PLANS FOR LIMITS
- HOT-MIX ASPHALT SURFACE REMOVAL, 1 3/4" & 1 1/4" HOT-MIX ASPHALT SURFACE COURSE, IL-9.5, MIX "D", N90
- AGGREGATE SHOULDERS, TYPE B

MODEL: Paving Plan Sheet 1
FILE NAME: Y:\DOT11445-1_74D08\74D08_DESIGN\CADD\Highway\CADD Sheets\ID774D08-shp-plan02.dgn



USER NAME = atn	DESIGNED - ATN	REVISED -
ESCA PROJECT NO. = 1445.01	DRAWN - ATN/NHC	REVISED -
PLOT DATE = 1/14/2026	CHECKED - ELH	REVISED -
	DATE - 01/26	REVISED -

**STATE OF ILLINOIS
DEPARTMENT OF TRANSPORTATION**

I-72 PAVING PLAN	
SCALE: 1" = 50'	SHEET 2 OF 2 SHEETS STA. TO STA.

F.A.I. RTE.	SECTION	COUNTY	TOTAL SHEETS	SHEET NO.
72	D7 BRIDGE REPAIRS 2026-3	MACON	108	13
CONTRACT NO. 74D08				
ILLINOIS FED. AID PROJECT				

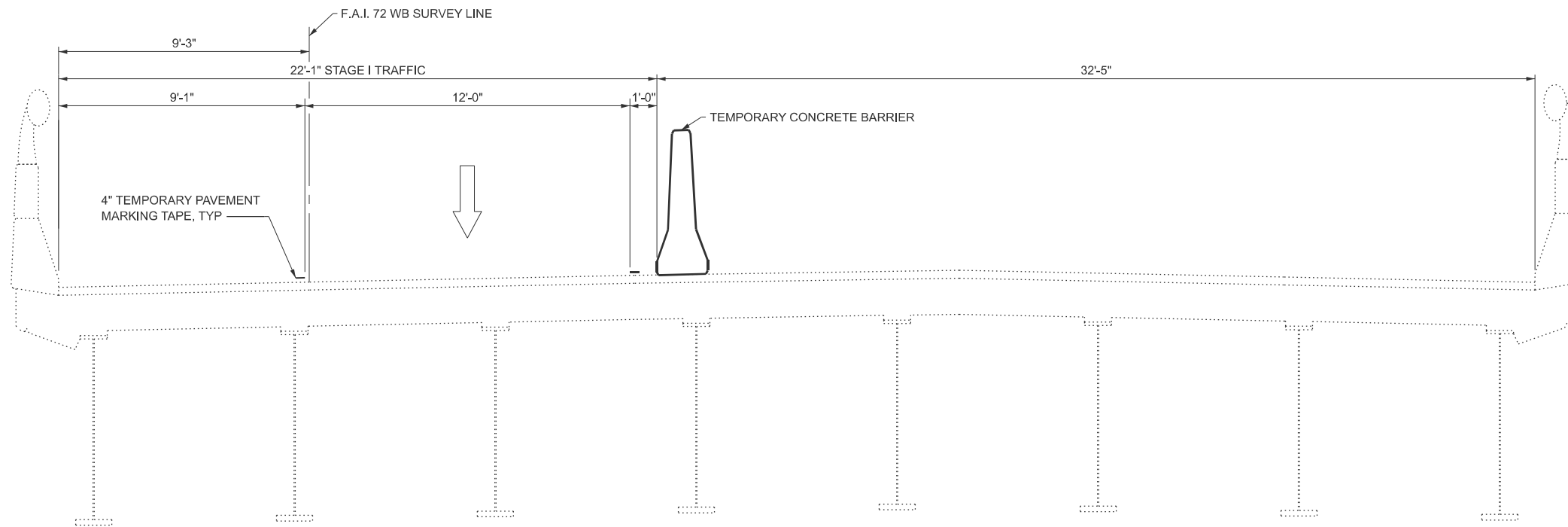

**SN 058-0068 WB
STAGE I CONSTRUCTION
(LOOKING NORTH)**

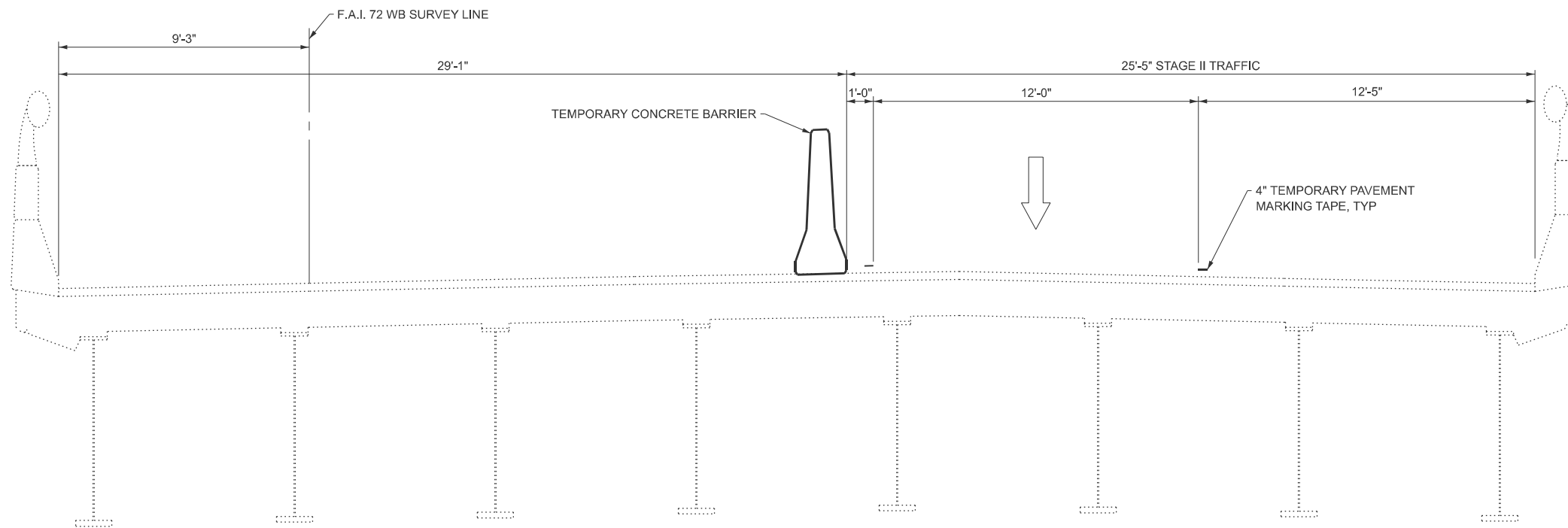

**SN 058-0068 WB
STAGE II CONSTRUCTION
(LOOKING NORTH)**

MODEL: Stage Construction Typical Sheet
FILE NAME: Y:\DOT\1445-01_74D08\74D08 DESIGN\CADD\Highway\CADD Sheets\ID774D08-sh1-stageing01.dgn



USER NAME = atn	DESIGNED - ATN	REVISED -
ESCA PROJECT NO. = 1445,01	DRAWN - ATN	REVISED -
	CHECKED - ELH	REVISED -
PLOT DATE = 7/18/2025	DATE - 01/26	REVISED -

**STATE OF ILLINOIS
DEPARTMENT OF TRANSPORTATION**

I-72			
TRAFFIC CONTROL TYPICAL SECTIONS			
SCALE: NONE	SHEET 1 OF 4 SHEETS	STA.	TO STA.

F.A.I. RTE.	SECTION	COUNTY	TOTAL SHEETS	SHEET NO.
72	D7 BRIDGE REPAIRS 2026-3	MACON	108	14
CONTRACT NO. 74D08				
ILLINOIS FED. AID PROJECT				

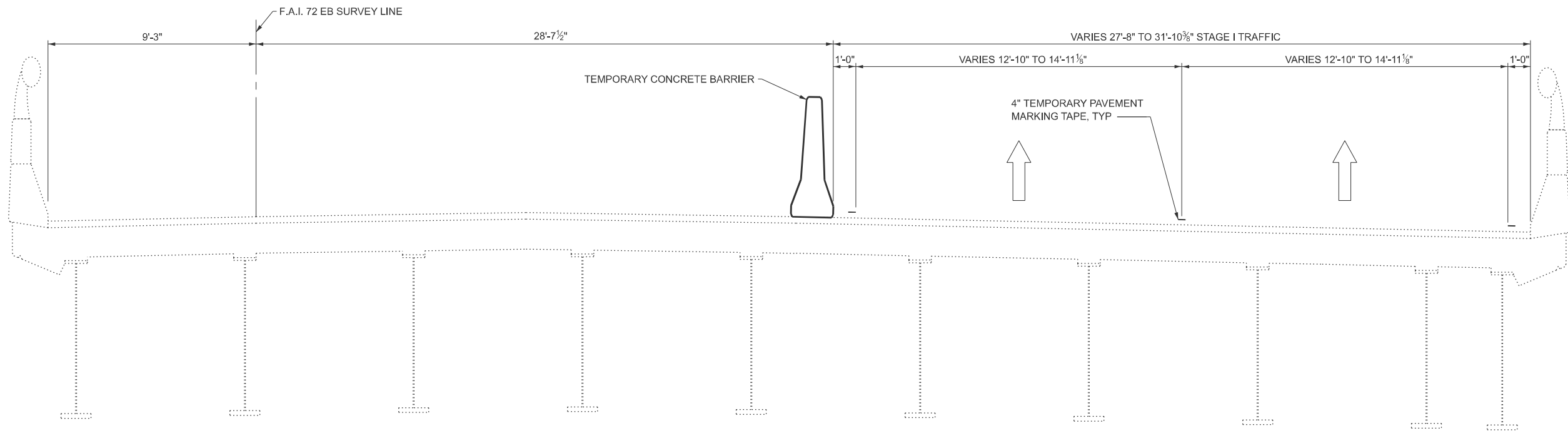

**SN 058-0069 EB
STAGE I CONSTRUCTION
(LOOKING NORTH)**

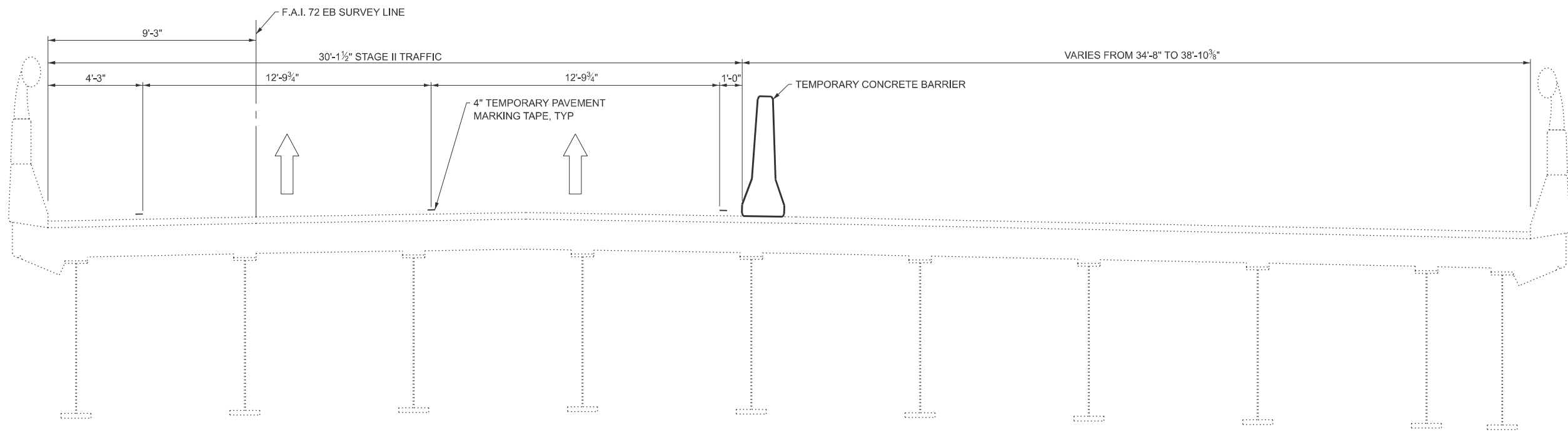

**SN 058-0069 EB
STAGE II CONSTRUCTION
(LOOKING NORTH)**

MODEL: Stage Construction Typical Sheet
FILE NAME: Y:\DOT\1445-01_74D08\74D08-EB-STAGEI.dgn



USER NAME = atn	DESIGNED - ATN	REVISED -
ESCA PROJECT NO. = 1445.01	DRAWN - ATN	REVISED -
	CHECKED - ELH	REVISED -
PLOT DATE = 7/25/2025	DATE - 01/26	REVISED -

**STATE OF ILLINOIS
DEPARTMENT OF TRANSPORTATION**

I-72		
TRAFFIC CONTROL TYPICAL SECTIONS		
SCALE: NONE	SHEET 2 OF 4 SHEETS	STA. TO STA.

F.A.I. RTE.	SECTION	COUNTY	TOTAL SHEETS	SHEET NO.
72	D7 BRIDGE REPAIRS 2026-3	MACON	108	15
CONTRACT NO. 74D08				
ILLINOIS FED. AID PROJECT				

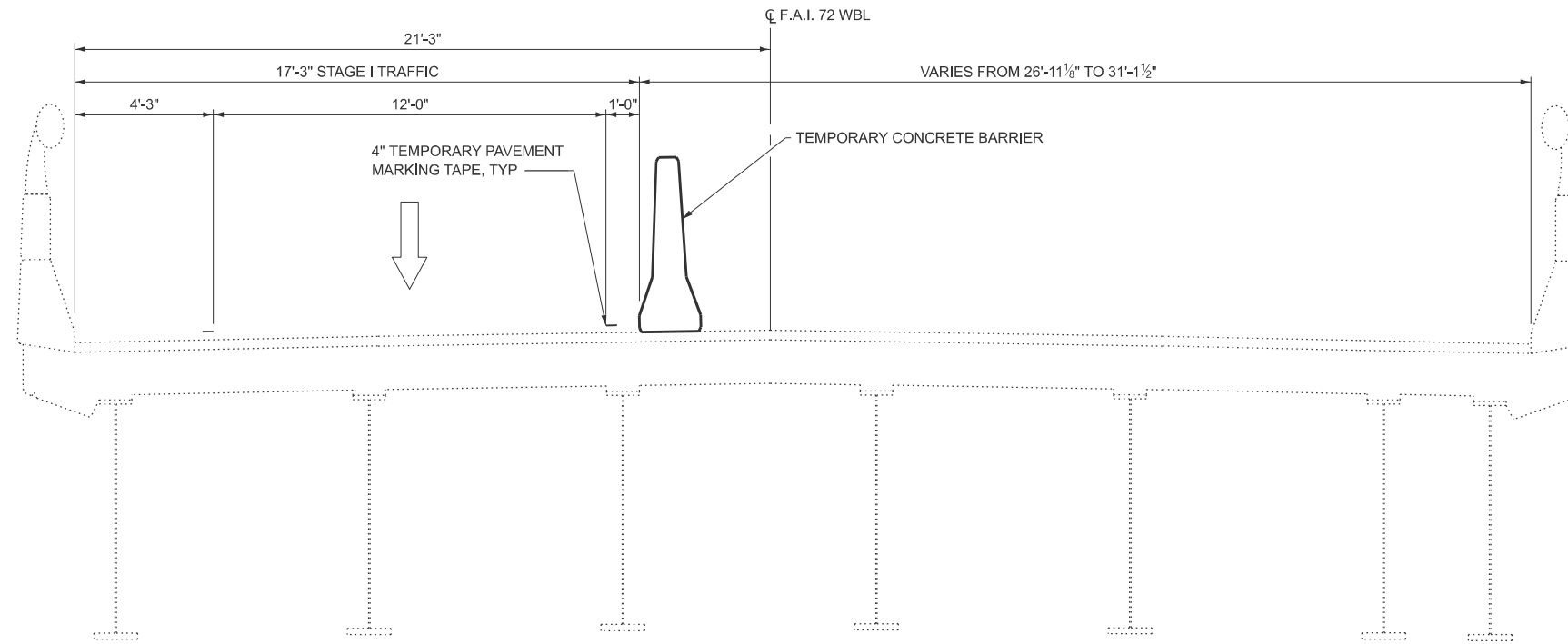

**SN 058-0070 WB
STAGE I CONSTRUCTION
(LOOKING NORTH)**

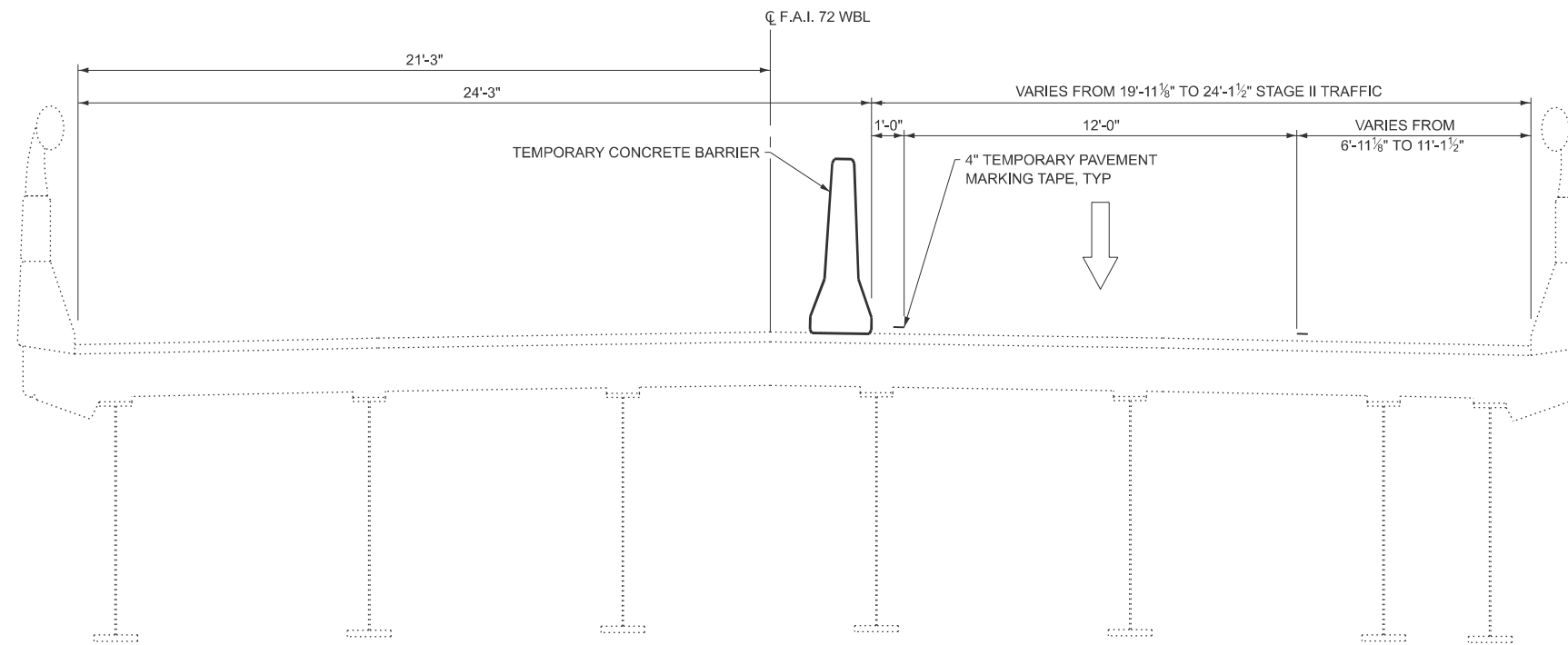

**SN 058-0070 WB
STAGE II CONSTRUCTION
(LOOKING NORTH)**

MODEL: Stage Construction Typical Sheet
FILE NAME: Y:\DOT\1445-01_74D08\74D08 DESIGN\CADD\Highway\CADD Sheets\ID774D08-sh1-stageing03.dgn



USER NAME = atn	DESIGNED - ATN	REVISED -
ESCA PROJECT NO. = 1445,01	DRAWN - ATN	REVISED -
	CHECKED - ELH	REVISED -
PLOT DATE = 7/25/2025	DATE - 01/26	REVISED -

**STATE OF ILLINOIS
DEPARTMENT OF TRANSPORTATION**

I-72			
TRAFFIC CONTROL TYPICAL SECTIONS			
SCALE: NONE	SHEET 3 OF 4 SHEETS	STA.	TO STA.

F.A.I. RTE.	SECTION	COUNTY	TOTAL SHEETS	SHEET NO.
72	D7 BRIDGE REPAIRS 2026-3	MACON	108	16
CONTRACT NO. 74D08				
ILLINOIS FED. AID PROJECT				

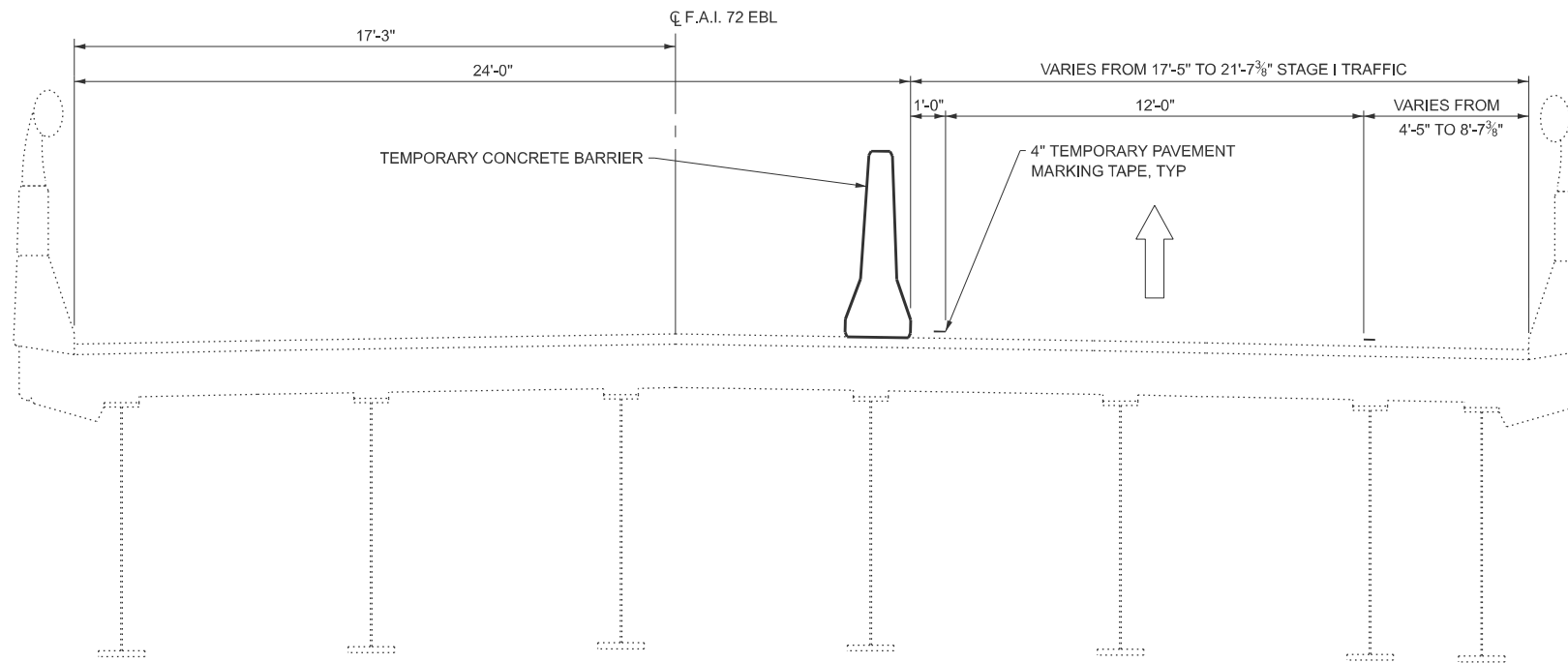

**SN 058-0071 EB
STAGE I CONSTRUCTION
(LOOKING NORTH)**

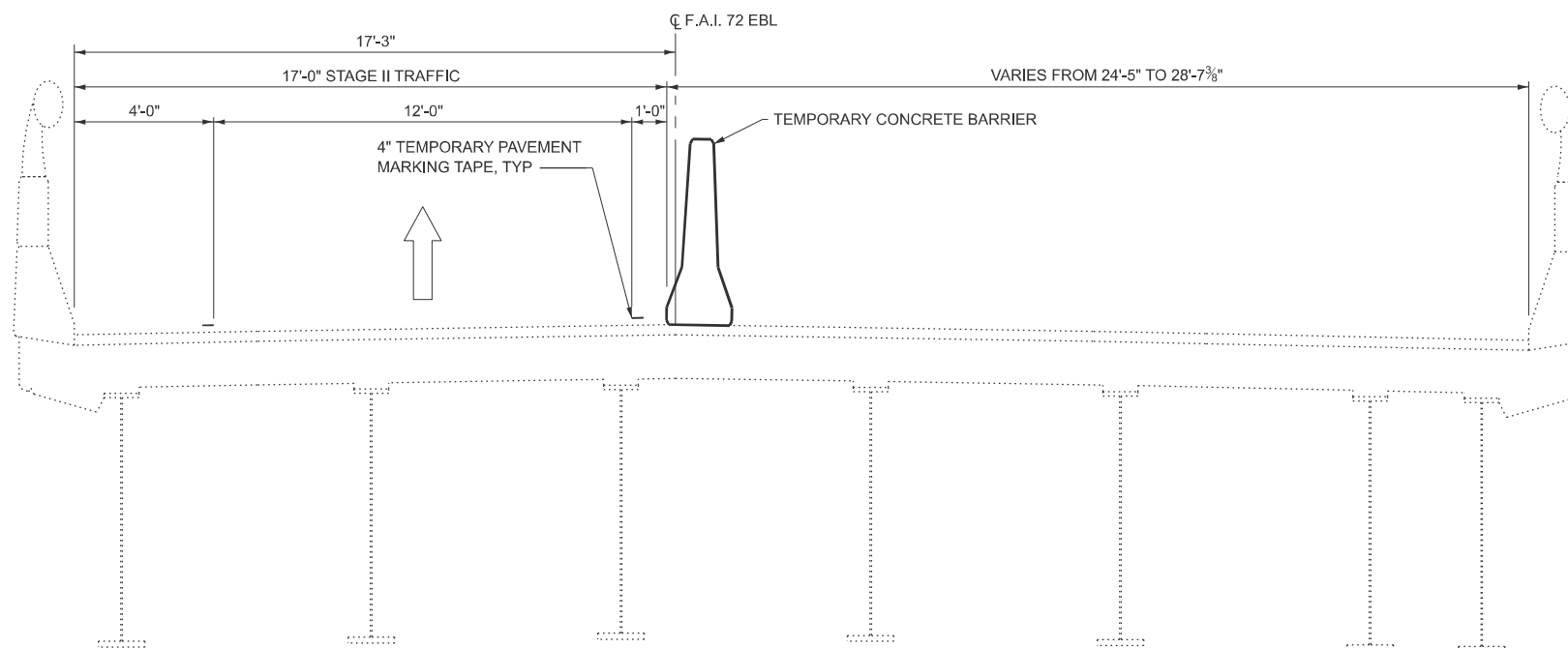

**SN 058-0071 EB
STAGE II CONSTRUCTION
(LOOKING NORTH)**

MODEL: Stage Construction Typical Sheet
FILE NAME: Y:\DOT\1445-01_74D08\74D08 DESIGN\CADD\Highway\CADD Sheets\ID774D08-sh1-stageing04.dgn



USER NAME = atn	DESIGNED - ATN	REVISED -
ESCA PROJECT NO. = 1445.01	DRAWN - ATN	REVISED -
	CHECKED - ELH	REVISED -
PLOT DATE = 9/10/2025	DATE - 01/26	REVISED -

**STATE OF ILLINOIS
DEPARTMENT OF TRANSPORTATION**

I-72			
TRAFFIC CONTROL TYPICAL SECTIONS			
SCALE: NONE	SHEET 4 OF 4 SHEETS	STA.	TO STA.

F.A.I. RTE.	SECTION	COUNTY	TOTAL SHEETS	SHEET NO.
72	D7 BRIDGE REPAIRS 2026-3	MACON	108	17
CONTRACT NO. 74D08				
ILLINOIS FED. AID PROJECT				

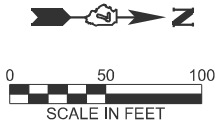

LEGEND

- ← DIRECTION OF TRAFFIC
- DRUM WITH STEADY BURN MONODIRECTIONAL LIGHT
- ↑ DIRECTION INDICATOR BARRICADE WITH STEADY BURN MONODIRECTIONAL LIGHT
- ← ARROW BOARD
- ↑ TYPE II BARRICADE WITH STEADY BURN MONODIRECTIONAL LIGHT
- ▨ PAVED SHOULDER REMOVAL AND PCC BASE COURSE WIDENING, 10"

GENERAL NOTES

1. SEE HIGHWAY STANDARD 701402 FOR ADDITIONAL DETAILS. THE COSTS FOR TEMPORARY PAVEMENT MARKING AND REMOVAL AND ADDITIONAL ITEMS SHOWN ON THESE SHEETS ARE INCLUDED IN THE PRICE FOR TRAFFIC CONTROL AND PROTECTION, STANDARD 701402.
2. SEE HIGHWAY STANDARD 701411 FOR ADDITIONAL DETAILS AT RAMP E.
3. SHOULDER RUMBLE STRIPS SHALL NOT BE INSTALLED UNTIL STAGED CONSTRUCTION IS FINISHED.
4. THE PRE-STAGE I CONSTRUCTION SHALL INCLUDE PAVED SHOULDER REMOVAL, PCC BASE COURSE WIDENING 10", PAVEMENT MARKING BLACKOUT TAPE 7" AND PAVEMENT MARKING BLACKOUT TAPE 9". SEE SCHEDULES OF QUANTITIES FOR LOCATIONS.

CURVE #1	F.A.I. RTE 72 EB
START	483+60.10
END	502+38.27
RADIUS	3433.72'
CURVE #3	F.A.I. RTE 72 EB
START	494+10.29
END	499+81.35
RADIUS	3303.54'

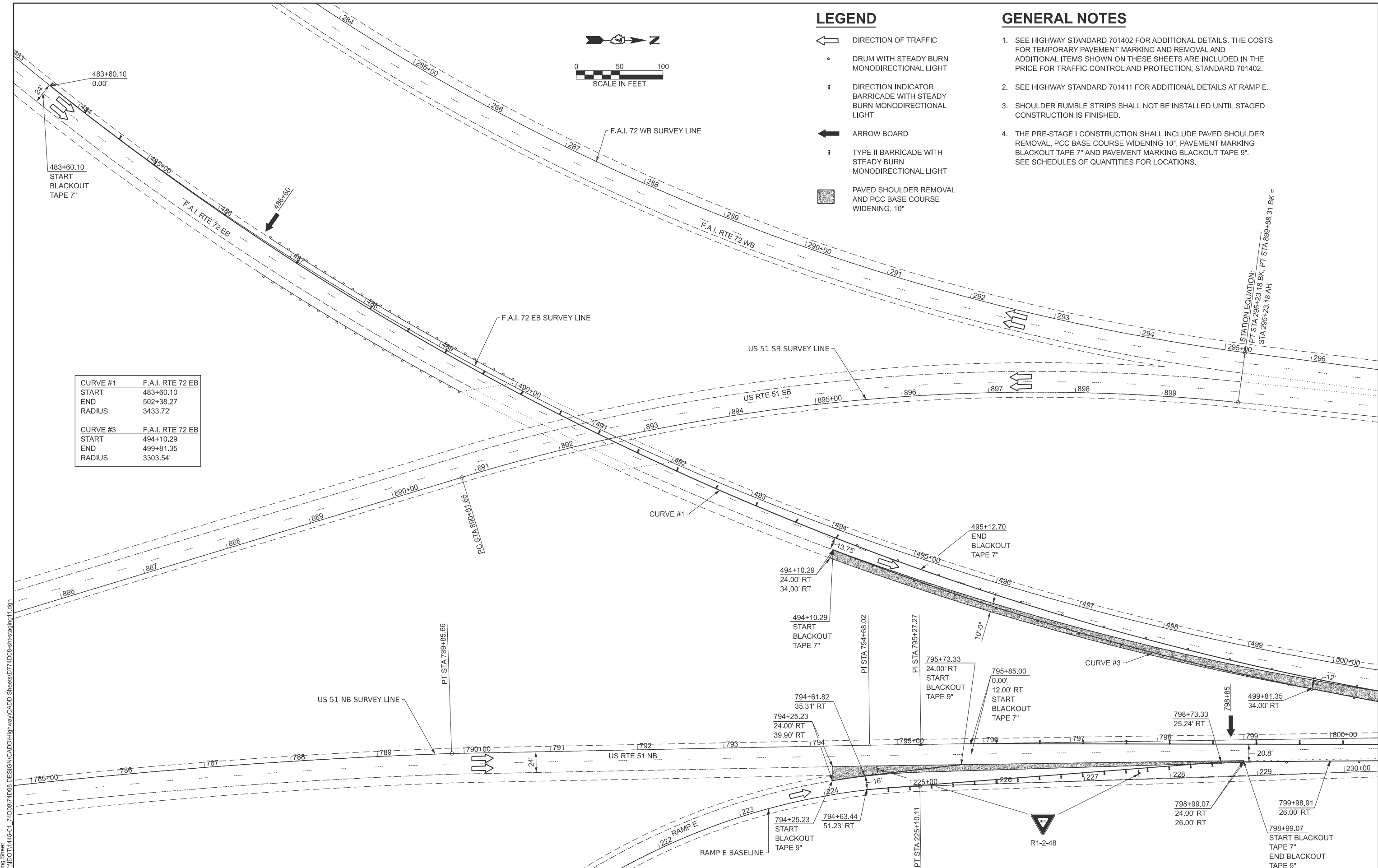

MODEL - Staging Sheet
 FILE NAME - Y:\DOT\11445-01_74D08\74D08_DESIGN\CADD\Highway\CADD Sheets\11445-01_74D08-shs-stage11.dgn



USER NAME = atn	DESIGNED - ATN	REVISED -
ESCA PROJECT NO. = 1445.01	DRAWN - ATN	REVISED -
PLOT DATE = 9/23/2025	CHECKED - ELH	REVISED -
	DATE - 01/26	REVISED -

**STATE OF ILLINOIS
DEPARTMENT OF TRANSPORTATION**

I-72 STAGE I TRAFFIC CONTROL PLAN	
SCALE: 1" = 50'	SHEET 1 OF 4 SHEETS
STA.	TO STA.

F.A.I. RTE.	SECTION	COUNTY	TOTAL SHEETS	SHEET NO.
72	D7 BRIDGE REPAIRS 2026-3	MACON	108	18
CONTRACT NO. 74D08				
ILLINOIS FED. AID PROJECT				

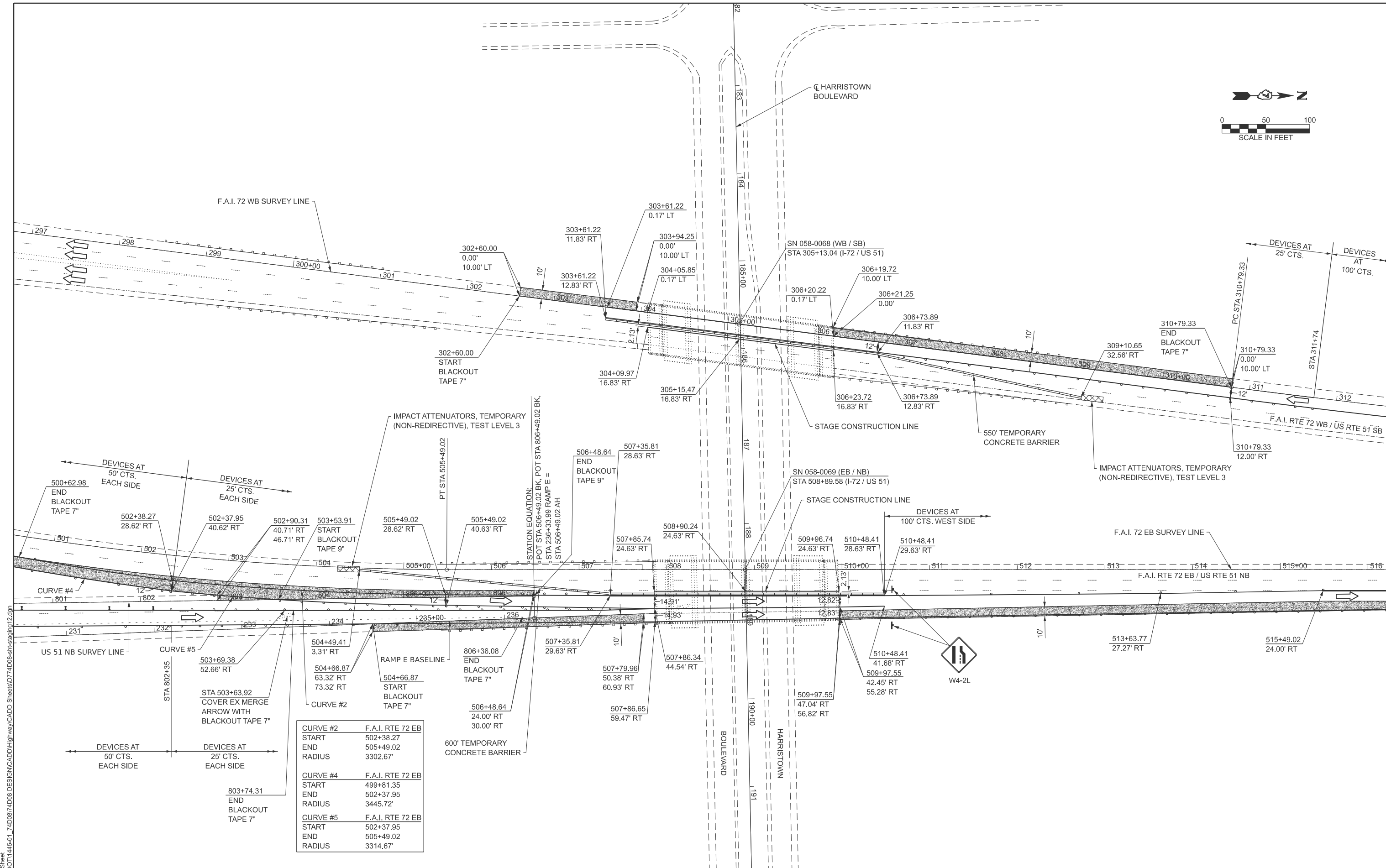
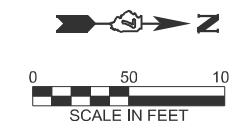

MODEL - Staging Sheet
 FILE NAME - Y:\IDOT\1445-01_74D08\74D08_DESIGN\CADD\Highway\CADD Sheets\ID774D08-shs-stage12.dgn



USER NAME = atn
 ESCA PROJECT NO. = 1445.01
 PLOT DATE = 9/23/2025

DESIGNED - ATN
 DRAWN - ATN
 CHECKED - ELH
 DATE - 01/26

REVISED -
 REVISED -
 REVISED -
 REVISED -

STATE OF ILLINOIS
DEPARTMENT OF TRANSPORTATION

I-72
STAGE I TRAFFIC CONTROL PLAN

SCALE: 1" = 50' SHEET 2 OF 4 SHEETS STA. TO STA.

F.A.I. RTE.	SECTION	COUNTY	TOTAL SHEETS	SHEET NO.
72	D7 BRIDGE REPAIRS 2026-3	MACON	108	19
CONTRACT NO. 74D08				
ILLINOIS FED. AID PROJECT				

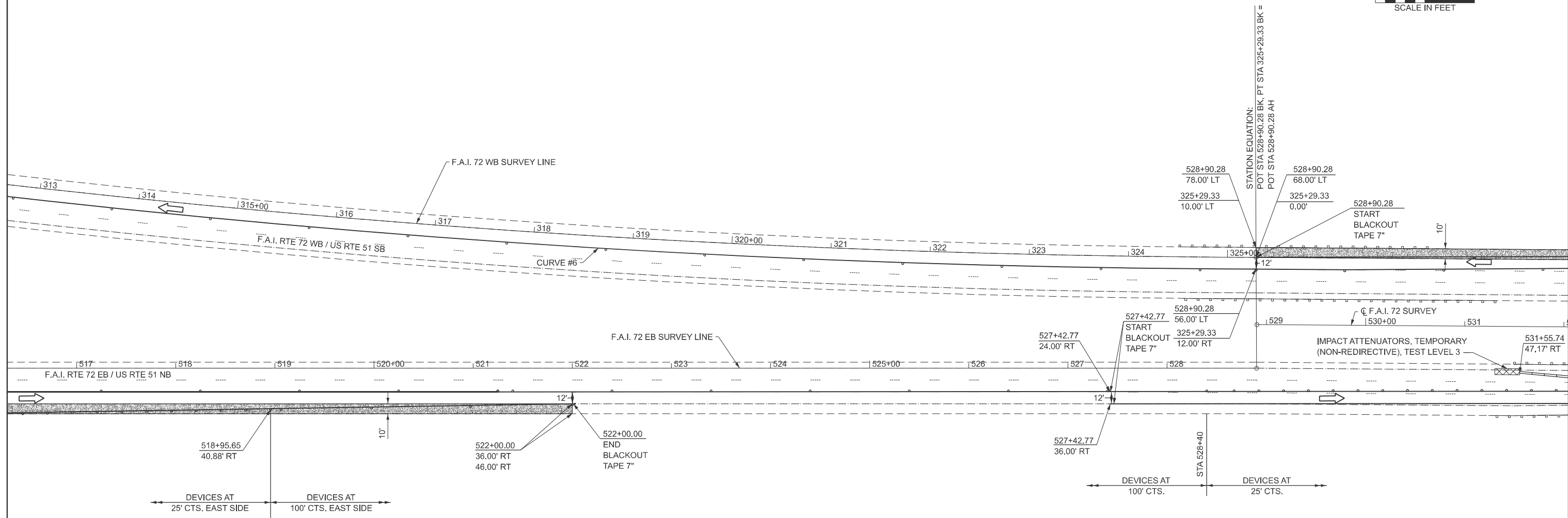
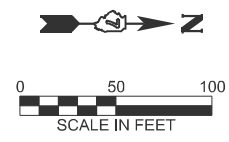

CURVE #	F.A.I. RTE 72 WB
START	310+79.33
END	325+29.33
RADIUS	11471.14'

MODEL: Staging Sheet
 FILE NAME: Y:\IDOT\1445-01_74D08\74D08_DESIGN\CADD\Highway\CADD Sheets\ID774D08-sh1-staging13.dgn



USER NAME = atn	DESIGNED - ATN	REVISED -
ESCA PROJECT NO. = 1445.01	DRAWN - ATN	REVISED -
PLOT DATE = 9/23/2025	CHECKED - ELH	REVISED -
	DATE - 01/26	REVISED -

STATE OF ILLINOIS
DEPARTMENT OF TRANSPORTATION

I-72	
STAGE I TRAFFIC CONTROL PLAN	
SCALE: 1" = 50'	SHEET 3 OF 4 SHEETS
STA.	TO STA.

F.A.I. RTE.	SECTION	COUNTY	TOTAL SHEETS	SHEET NO.
72	D7 BRIDGE REPAIRS 2026-3	MACON	108	20
CONTRACT NO. 74D08				
ILLINOIS FED. AID PROJECT				

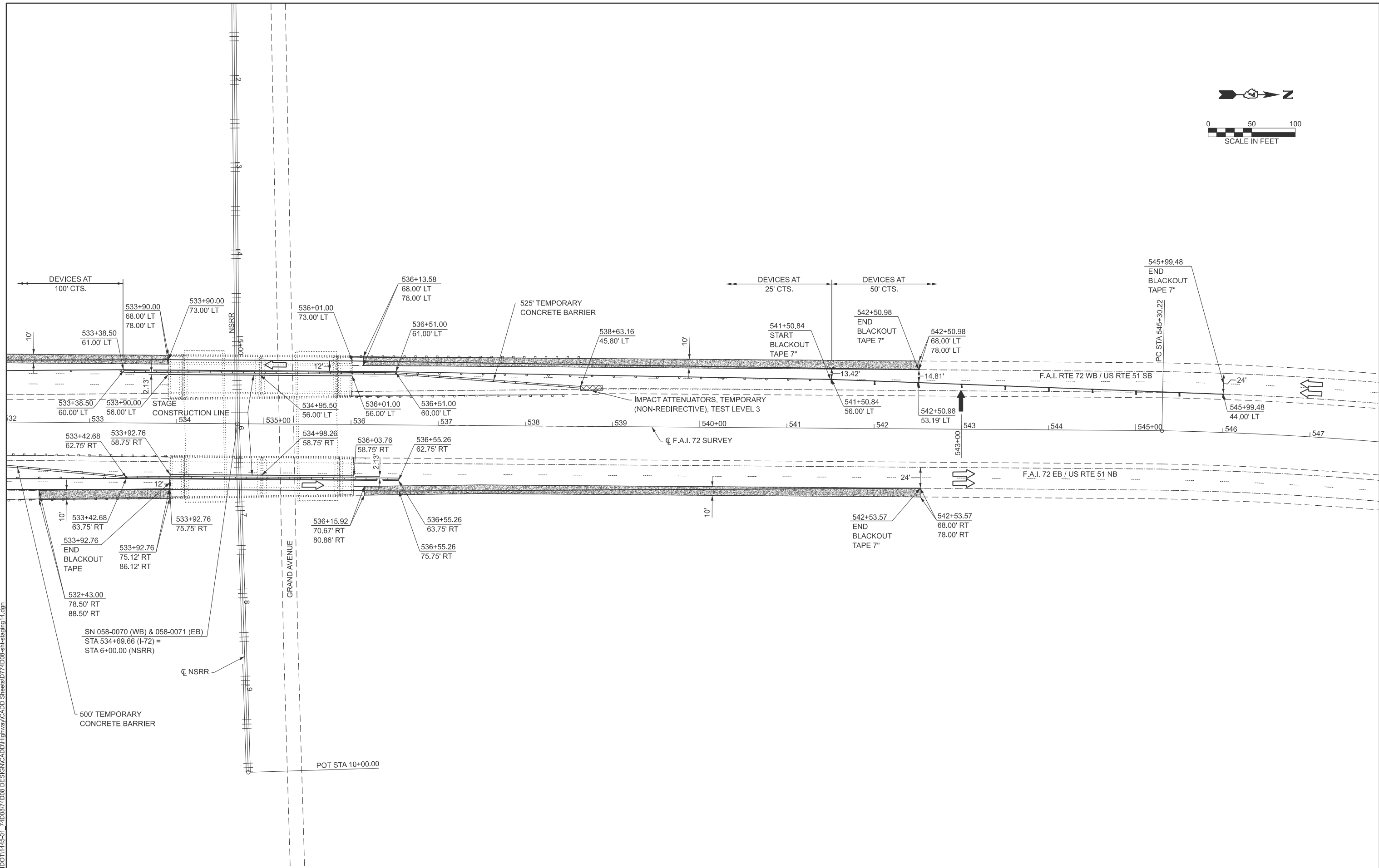
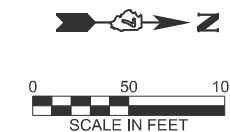

MODEL: Stage1g Sheet
 FILE NAME: Y:\DOT\1445-01_74D08\74D08_DESIGN\CADD\Highway\CADD Sheets\1445-01_74D08-sh1-stage1g14.dgn



USER NAME = atn	DESIGNED - ATN	REVISED -
ESCA PROJECT NO. = 1445,01	DRAWN - ATN	REVISED -
PLOT DATE = 9/23/2025	CHECKED - ELH	REVISED -
	DATE - 01/26	REVISED -

STATE OF ILLINOIS
DEPARTMENT OF TRANSPORTATION

I-72	
STAGE I TRAFFIC CONTROL PLAN	
SCALE: 1" = 50'	SHEET 4 OF 4 SHEETS
STA.	TO STA.

F.A.I. RTE.	SECTION	COUNTY	TOTAL SHEETS	SHEET NO.
72	D7 BRIDGE REPAIRS 2026-3	MACON	108	21
CONTRACT NO. 74D08				
ILLINOIS FED. AID PROJECT				

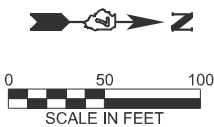

LEGEND

- ← DIRECTION OF TRAFFIC
- DRUM WITH STEADY BURN MONODIRECTIONAL LIGHT
- ⊥ DIRECTION INDICATOR BARRICADE WITH STEADY BURN MONODIRECTIONAL LIGHT
- ← ARROW BOARD
- ⊥ TYPE II BARRICADE WITH STEADY BURN MONODIRECTIONAL LIGHT
- ▨ PAVED SHOULDER REMOVAL AND PCC BASE COURSE WIDENING, 10"

GENERAL NOTES

1. SEE HIGHWAY STANDARD 701402 FOR ADDITIONAL DETAILS. THE COSTS FOR TEMPORARY PAVEMENT MARKING AND REMOVAL AND ADDITIONAL ITEMS SHOWN ON THESE SHEETS ARE INCLUDED IN THE PRICE FOR TRAFFIC CONTROL AND PROTECTION, STANDARD 701402.
2. SEE HIGHWAY STANDARD 701411 FOR ADDITIONAL DETAILS AT RAMP E.
3. SHOULDER RUMBLE STRIPS SHALL NOT BE INSTALLED UNTIL STAGED CONSTRUCTION IS FINISHED.
4. THE PRE-STAGE II CONSTRUCTION SHALL INCLUDE PAVED SHOULDER REMOVAL, PCC BASE COURSE WIDENING 10", PAVEMENT MARKING BLACKOUT TAPE 7" AND PAVEMENT MARKING BLACKOUT TAPE 9". SEE SCHEDULES OF QUANTITIES FOR LOCATIONS.

CURVE #1	F.A.I. RTE 72 EB
START	491+95.75
END	502+35.75
RADIUS	3298.00'

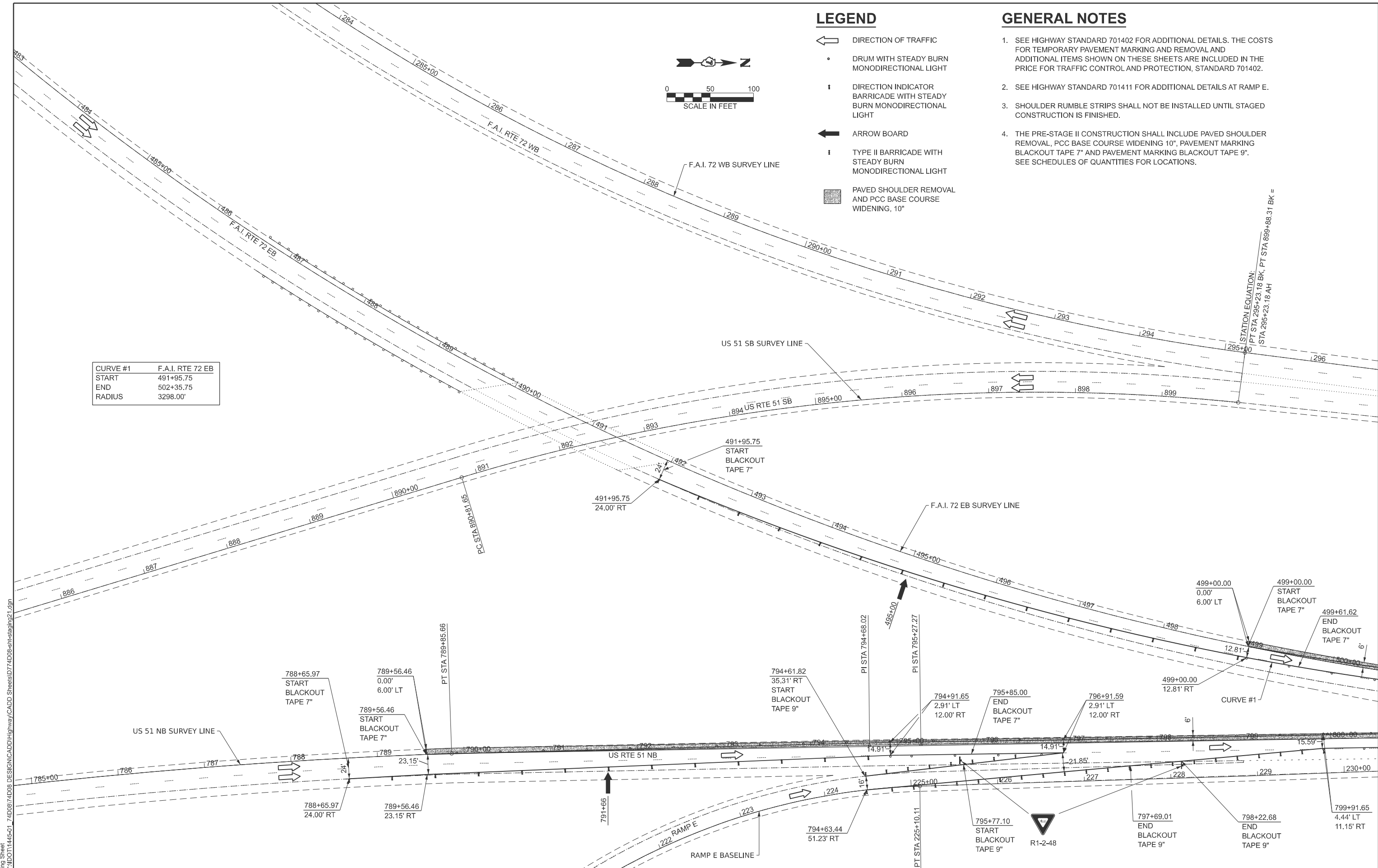

MODEL - Staging Sheet
 FILE NAME - Y:\IDOT\1445-01_74D08\74D08_DESIGN\CADD\Highway\CADD Sheets\ID74D08-sh1-stage21.dgn



USER NAME = atn	DESIGNED - ATN	REVISED -
ESCA PROJECT NO. = 1445.01	DRAWN - ATN	REVISED -
PLOT DATE = 1/15/2026	CHECKED - ELH	REVISED -
	DATE - 01/26	REVISED -

**STATE OF ILLINOIS
DEPARTMENT OF TRANSPORTATION**

**I-72
STAGE II TRAFFIC CONTROL PLAN**

SCALE: 1" = 50' SHEET 1 OF 4 SHEETS STA. TO STA.

F.A.I. RTE.	SECTION	COUNTY	TOTAL SHEETS	SHEET NO.
72	D7 BRIDGE REPAIRS 2026-3	MACON	108	22
CONTRACT NO. 74D08				
ILLINOIS FED. AID PROJECT				

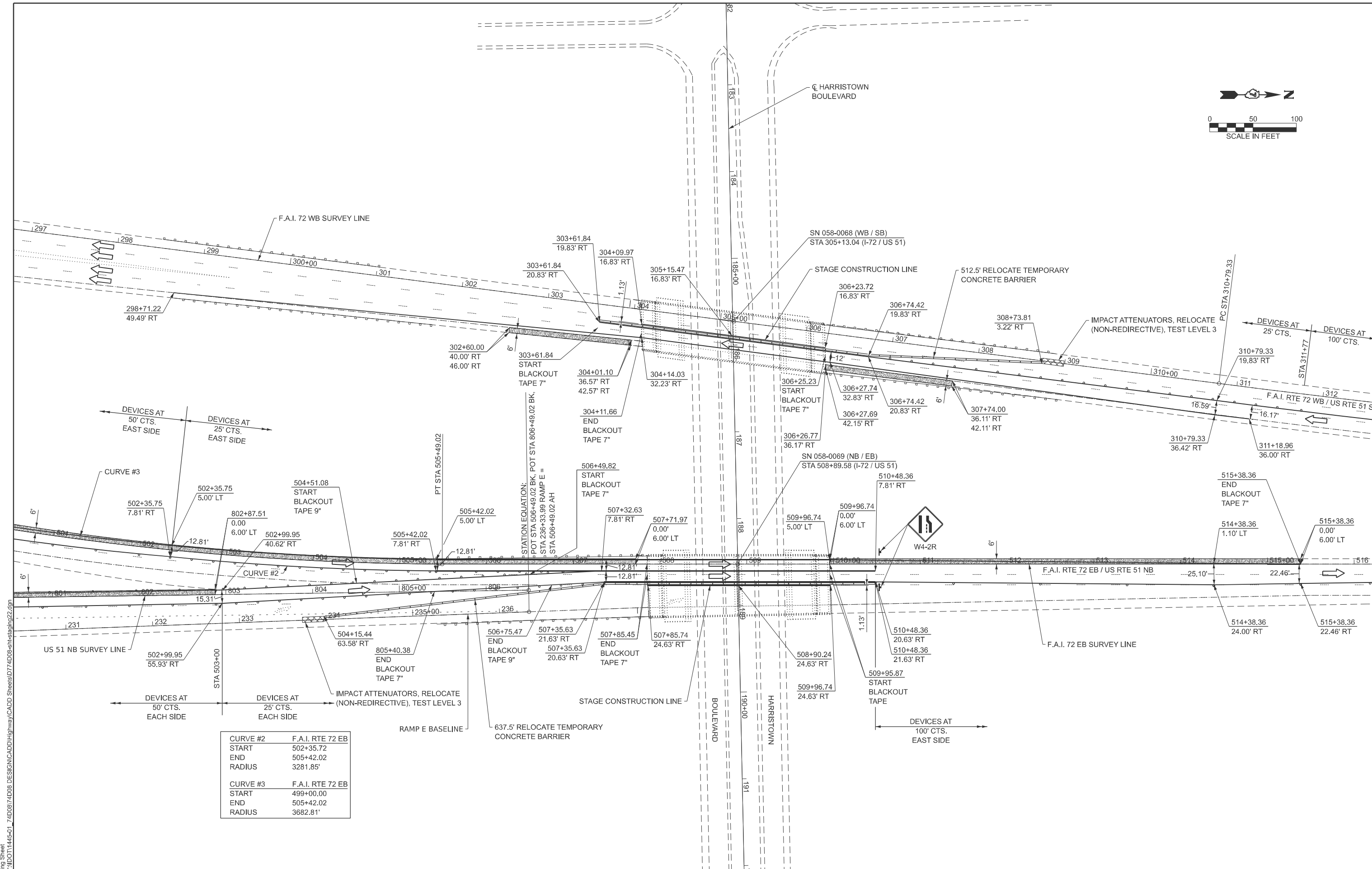
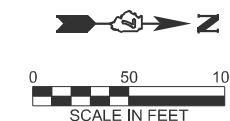

CURVE #2	F.A.I. RTE 72 EB
START	502+35.72
END	505+42.02
RADIUS	3281.85'
CURVE #3	F.A.I. RTE 72 EB
START	499+00.00
END	505+42.02
RADIUS	3682.81'

MODEL - Staging Sheet
 FILE NAME - Y:\IDOT\1445-01_74D08\74D08_DESIGN\CADD\Highway\CADD Sheets\1445-01_74D08-shs-stage2.dwg



USER NAME = atn
 ESCA PROJECT NO. = 1445.01
 PLOT DATE = 9/23/2025

DESIGNED - ATN
 DRAWN - ATN
 CHECKED - ELH
 DATE - 01/26

REVISED -
 REVISED -
 REVISED -
 REVISED -

STATE OF ILLINOIS
DEPARTMENT OF TRANSPORTATION

I-72
STAGE II TRAFFIC CONTROL PLAN

SCALE: 1" = 50' SHEET 2 OF 4 SHEETS STA. TO STA.

F.A.I. RTE.	SECTION	COUNTY	TOTAL SHEETS	SHEET NO.
72	D7 BRIDGE REPAIRS 2026-3	MACON	108	23
CONTRACT NO. 74D08				
ILLINOIS FED. AID PROJECT				

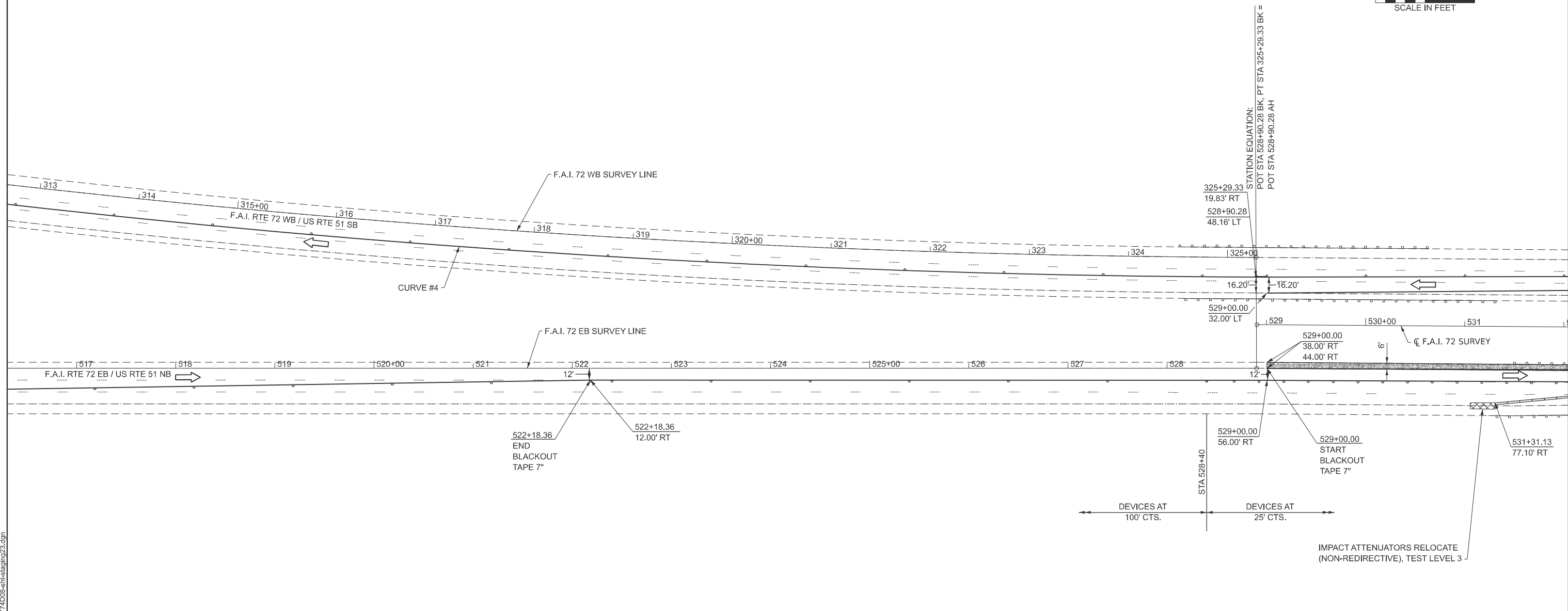
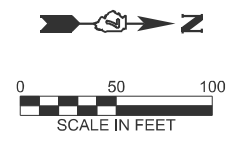

CURVE #4	F.A.I. RTE 72 WB
START	310+79.33
END	325+29.33
RADIUS	11478.98'

MODEL: Staging Sheet
 FILE NAME: Y:\DOT11445-01_74D08\74D08_DESIGN\CADD\Highway\CADD Sheets\I774D08-sh1-staging23.dgn



USER NAME = atn	DESIGNED - ATN	REVISED -
ESCA PROJECT NO. = 1445.01	DRAWN - ATN	REVISED -
PLOT DATE = 9/23/2025	CHECKED - ELH	REVISED -
	DATE - 01/26	REVISED -

**STATE OF ILLINOIS
DEPARTMENT OF TRANSPORTATION**

I-72	
STAGE II TRAFFIC CONTROL PLAN	
SCALE: 1" = 50'	SHEET 3 OF 4 SHEETS STA. TO STA.

F.A.I. RTE.	SECTION	COUNTY	TOTAL SHEETS	SHEET NO.
72	D7 BRIDGE REPAIRS 2026-3	MACON	108	24
CONTRACT NO. 74D08				
ILLINOIS FED. AID PROJECT				

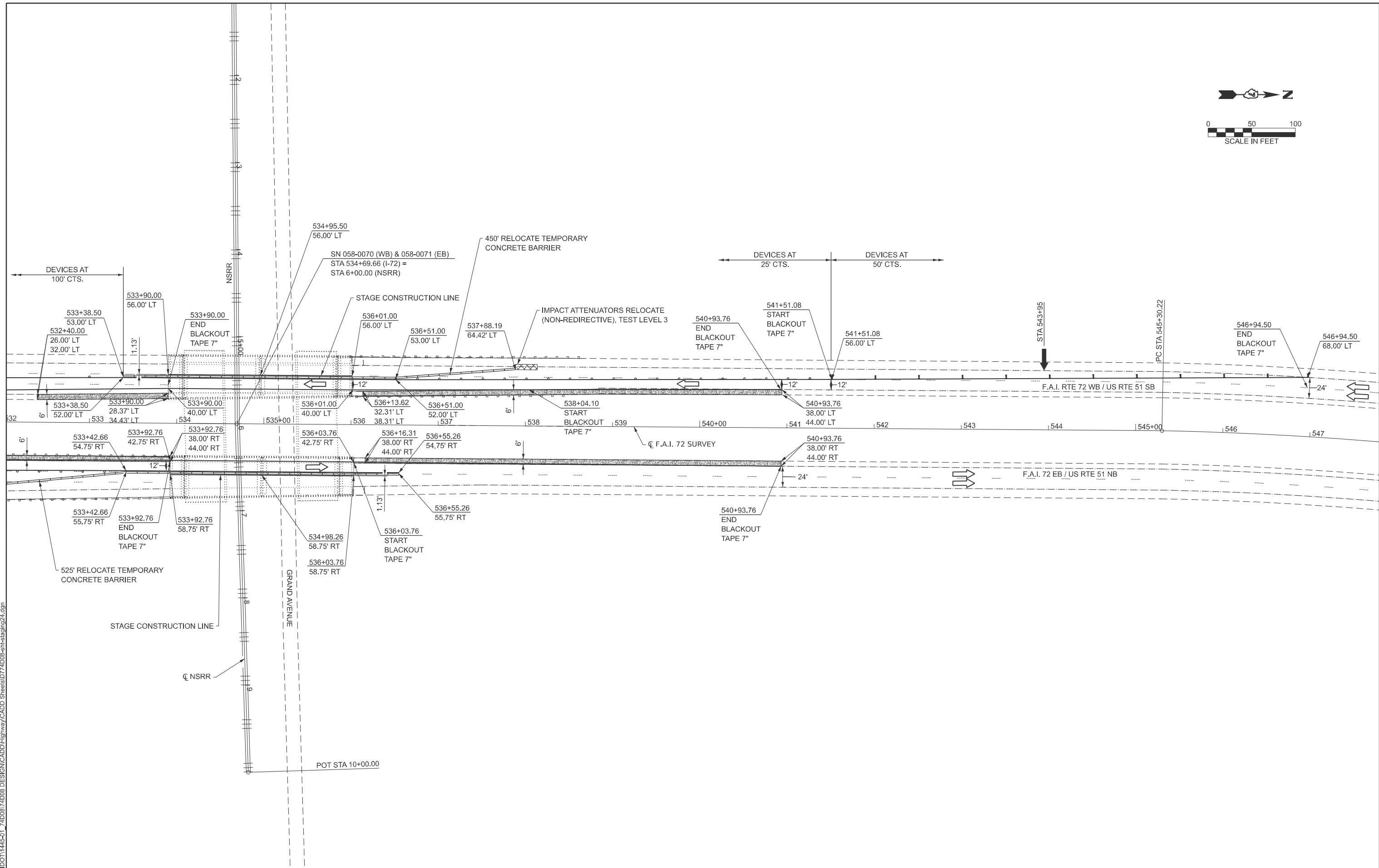

MODEL: Staging Sheet
 FILE NAME: Y:\DOT\1445-01_74D08\74D08_DESIGN\CADD\Highway\CADD Sheets\1445-01_74D08-shs-staging24.dgn







USER NAME = atn	DESIGNED - ATN	REVISED -
ESCA PROJECT NO. = 1445,01	DRAWN - ATN	REVISED -
PLOT DATE = 9/23/2025	CHECKED - ELH	REVISED -
	DATE - 01/26	REVISED -

STATE OF ILLINOIS
DEPARTMENT OF TRANSPORTATION

I-72		
STAGE II TRAFFIC CONTROL PLAN		
SCALE: 1" = 50'	SHEET 4 OF 4 SHEETS	STA. TO STA.

F.A.I. RTE.	SECTION	COUNTY	TOTAL SHEETS	SHEET NO.
72	D7 BRIDGE REPAIRS 2026-3	MACON	108	25
CONTRACT NO. 74D08				
ILLINOIS FED. AID PROJECT				

LEGEND

-  DIRECTION INDICATOR BARRICADE WITH STEADY BURN MONODIRECTIONAL LIGHT
-  DIRECTION OF TRAFFIC
-  SIGN
-  ARROW BOARD
-  TYPE II BARRICADE, DRUM, OR VERTICAL BARRICADE



NOTES:

1. USE THESE DETAILS IN CONJUNCTION WITH STANDARD 701422. THE COSTS FOR TEMPORARY PAVEMENT MARKING AND REMOVAL AND ADDITIONAL ITEMS SHOWN ON THESE SHEETS ARE INCLUDED IN THE PRICE FOR TRAFFIC CONTROL AND PROTECTION, STANDARD 701402.
2. THE INTERSECTION OF HARRISTOWN BLVD AND N GLASGOW RD SHALL STAY OPEN DURING STAGE CONSTRUCTION.
3. THE INTERSECTION OF HARRISTOWN BLVD AND N WESTERN AVE SHALL STAY OPEN DURING STAGE CONSTRUCTION.
4. THE W20-7(0)-48 SIGNS SHALL BE REMOVED/COVERED/TURNED WHEN FLAGGERS ARE NOT PRESENT.

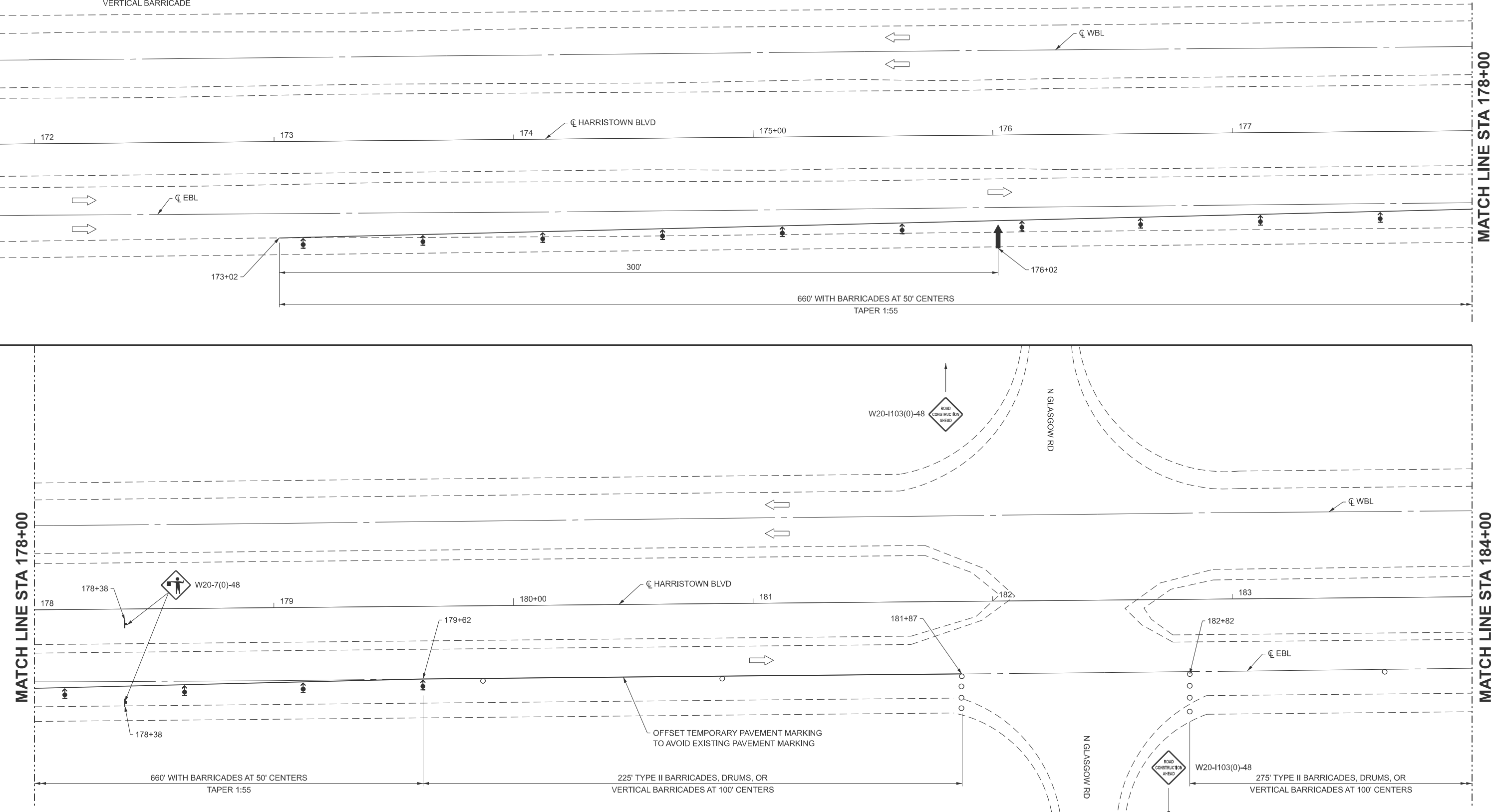

MODEL: Harristown Blvd Striping Sheet
FILE NAME: Y:\IDOT\1445-01_74D08\74D08_DESIGN\CADD\Highway\CADD Sheets\ID774D08-shs-striping41.dgn



USER NAME = atn	DESIGNED - ATN	REVISED -
ESCA PROJECT NO. = 1445.01	DRAWN - ATN	REVISED -
PLOT DATE = 9/23/2025	CHECKED - ELH	REVISED -
	DATE - 01/26	REVISED -

**STATE OF ILLINOIS
DEPARTMENT OF TRANSPORTATION**

**HARRISTOWN BOULEVARD
STAGE I TRAFFIC CONTROL PLAN**

SCALE: 1" = 20' SHEET 1 OF 3 SHEETS STA. TO STA.

F.A.I. RTE.	SECTION	COUNTY	TOTAL SHEETS	SHEET NO.
72	D7 BRIDGE REPAIRS 2026-3	MACON	108	26
CONTRACT NO. 74D08				
ILLINOIS FED. AID PROJECT				



G20-1103-6036

END WORK ZONE SPEED LIMIT

185+16

F.A.I. 72 WB SURVEY LINE

TYPE II BARRICADES, DRUMS, OR VERTICAL BARRICADES AT 100' CENTERS UNTIL END OF WORK ZONE

500' TYPE II BARRICADES, DRUMS, OR VERTICAL BARRICADES AT 100' CENTERS

F.A.I. 72 EB SURVEY LINE

MATCH LINE STA 184+00

MATCH LINE STA 190+00

184

185+00

185+16

186

SN 058-0068

187

CL HARRISTOWN BLVD

188

189

SN 058-0069

275' TYPE II BARRICADES, DRUMS, OR VERTICAL BARRICADES AT 100' CENTERS

TYPE II BARRICADES, DRUMS, OR VERTICAL BARRICADES AT 100' CENTERS UNTIL END OF WORK ZONE

150'-0"

500' TYPE II BARRICADES, DRUMS, OR VERTICAL BARRICADES AT 100' CENTERS

660' WITH BARRICADES AT 50' CENTERS TAPER 1:55

OFFSET TEMPORARY PAVEMENT MARKING TO AVOID EXISTING PAVEMENT MARKING

CL WBL

191+12

192

CL HARRISTOWN BLVD

193

194+12

CL EBL

195+37

W20-7(0)-48

MATCH LINE STA 190+00

MATCH LINE STA 196+00

190+64

190+64

150'-0"

G20-1103-6036

END WORK ZONE SPEED LIMIT

MODEL: Harristown Blvd Striping Sheet
FILE NAME: Y:\DOT\1445-01_74D08\74D08_DESIGN\CADD\Highway\CADD Sheets\174D08-shs-striping42.dgn



USER NAME = atn
ESCA PROJECT NO. = 1445,01
PLOT DATE = 9/10/2025

DESIGNED - ATN
DRAWN - ATN
CHECKED - ELH
DATE - 01/26

REVISED -
REVISED -
REVISED -
REVISED -

STATE OF ILLINOIS
DEPARTMENT OF TRANSPORTATION

HARRISTOWN BOULEVARD
STAGE I TRAFFIC CONTROL PLAN

SCALE: 1" = 20'

SHEET 2 OF 3 SHEETS

STA.

TO STA.

F.A.I. RTE.	SECTION	COUNTY	TOTAL SHEETS	SHEET NO.
72	D7 BRIDGE REPAIRS 2026-3	MACON	108	27
CONTRACT NO. 74D08				
ILLINOIS FED. AID PROJECT				

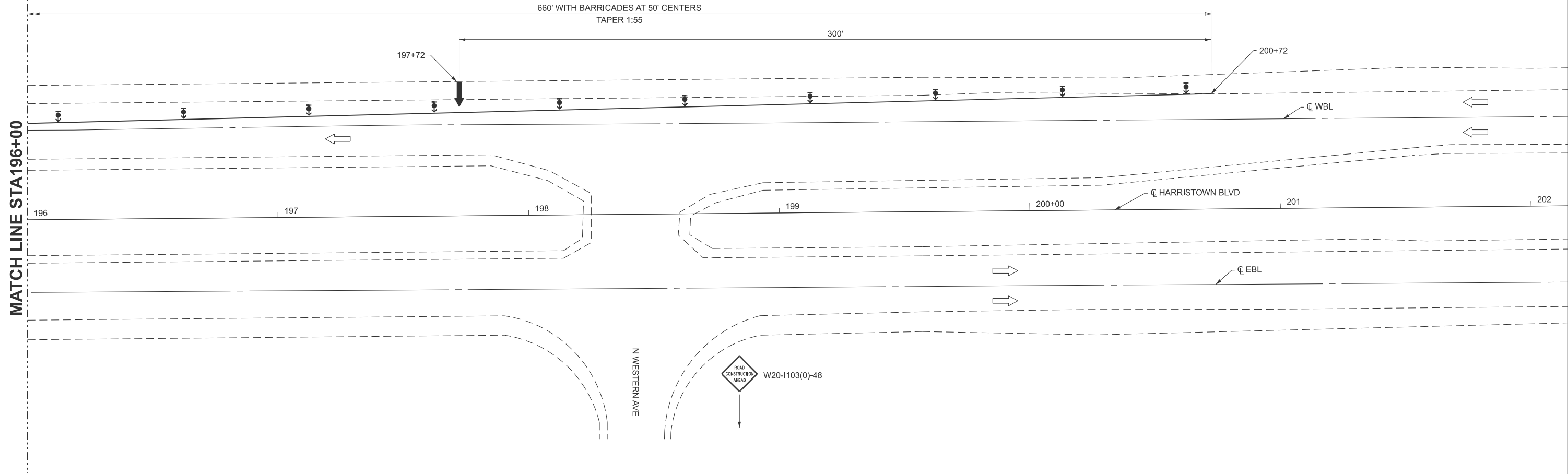

MODEL: Harristown Blvd Striping Sheet
 FILE NAME: Y:\DOT\1445-01_74D08\74D08 DESIGN\CADD\Highway\CADD Sheets\ID774D08-sh1-striping43.dgn



USER NAME = atn	DESIGNED - ATN	REVISED -
ESCA PROJECT NO. = 1445.01	DRAWN - ATN	REVISED -
PLOT DATE = 9/10/2025	CHECKED - ELH	REVISED -
	DATE - 01/26	REVISED -





**STATE OF ILLINOIS
 DEPARTMENT OF TRANSPORTATION**

**HARRISTOWN BOULEVARD
 STAGE I TRAFFIC CONTROL PLAN**

SCALE: 1" = 20' SHEET 3 OF 3 SHEETS STA. TO STA.

F.A.I. RTE.	SECTION	COUNTY	TOTAL SHEETS	SHEET NO.
72	D7 BRIDGE REPAIRS 2026-3	MACON	108	28
CONTRACT NO. 74D08				
ILLINOIS FED. AID PROJECT				

LEGEND

-  DIRECTION INDICATOR BARRICADE WITH STEADY BURN MONODIRECTIONAL LIGHT
-  DIRECTION OF TRAFFIC
-  SIGN
-  ARROW BOARD
-  TYPE II BARRICADE, DRUM, OR VERTICAL BARRICADE



NOTES:

1. USE THESE DETAILS IN CONJUNCTION WITH STANDARD 701422. THE COSTS FOR TEMPORARY PAVEMENT MARKING AND REMOVAL AND ADDITIONAL ITEMS SHOWN ON THESE SHEETS ARE INCLUDED IN THE PRICE FOR TRAFFIC CONTROL AND PROTECTION, STANDARD 701402.
2. THE INTERSECTION OF HARRISTOWN BLVD AND N GLASGOW RD SHALL STAY OPEN DURING STAGE CONSTRUCTION.
3. THE INTERSECTION OF HARRISTOWN BLVD AND N WESTERN AVE SHALL STAY OPEN DURING STAGE CONSTRUCTION.
4. THE W20-7(0)-48 SIGNS SHALL BE REMOVED/COVERED/TURNED WHEN FLAGGERS ARE NOT PRESENT.

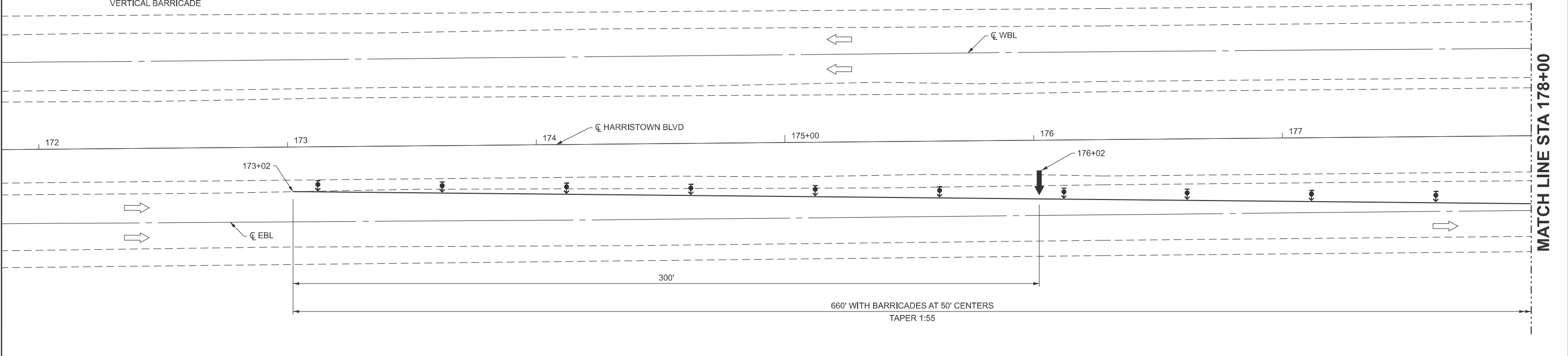

MATCH LINE STA 178+00

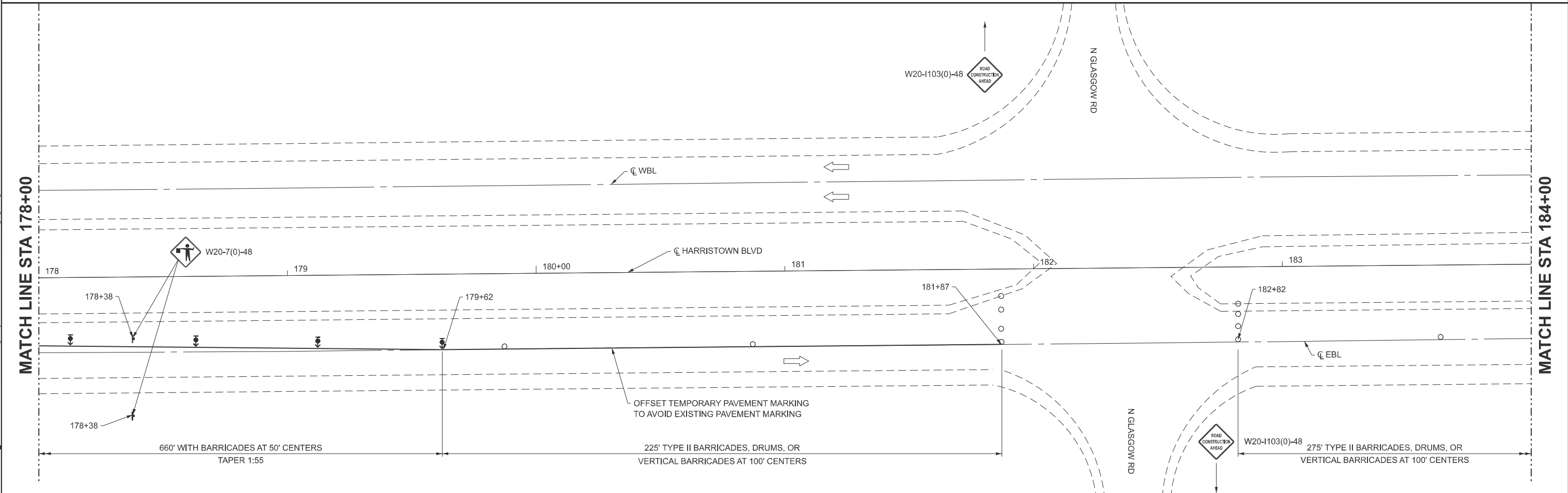

MATCH LINE STA 178+00

MATCH LINE STA 184+00

MODEL: Harristown Blvd Staging Sheet
FILE NAME: Y:\IDOT\1445-01_74D08\74D08_DESIGN\CADD\Highway\CADD Sheets\ID774D08-sh1-staging51.dgn



USER NAME = atn	DESIGNED - ATN	REVISED -
ESCA PROJECT NO. = 1445.01	DRAWN - ATN	REVISED -
PLOT DATE = 9/12/2025	CHECKED - ELH	REVISED -
	DATE - 01/26	REVISED -

**STATE OF ILLINOIS
DEPARTMENT OF TRANSPORTATION**

**HARRISTOWN BOULEVARD
STAGE II TRAFFIC CONTROL PLAN**

SCALE: 1" = 20' SHEET 1 OF 3 SHEETS STA. TO STA.

F.A.I. RTE.	SECTION	COUNTY	TOTAL SHEETS	SHEET NO.
72	D7 BRIDGE REPAIRS 2026-3	MACON	108	29
CONTRACT NO. 74D08				
ILLINOIS FED. AID PROJECT				



MATCH LINE STA 184+00

MATCH LINE STA 190+00

G20-1103-6036
END WORK ZONE SPEED LIMIT



50'
185+16

F.A.I. 72 WB SURVEY LINE

TYPE II BARRICADES, DRUMS, OR VERTICAL BARRICADES AT 100' CENTERS UNTIL END OF WORK ZONE

F.A.I. 72 EB SURVEY LINE

500' TYPE II BARRICADES, DRUMS, OR VERTICAL BARRICADES AT 100' CENTERS

185+00

185+16

186

SN 058-0068

187
HARRISTOWN BLVD

188

189

SN 058-0069

275' TYPE II BARRICADES, DRUMS, OR VERTICAL BARRICADES AT 100' CENTERS

TYPE II BARRICADES, DRUMS, OR VERTICAL BARRICADES AT 100' CENTERS UNTIL END OF WORK ZONE

150'-0"

MATCH LINE STA 190+00

MATCH LINE STA 196+00

500' TYPE II BARRICADES, DRUMS, OR VERTICAL BARRICADES AT 100' CENTERS

372' WITH BARRICADES AT 50' CENTERS
TAPER 1:31

OFFSET TEMPORARY PAVEMENT MARKING TO AVOID EXISTING PAVEMENT MARKING

191+12

HARRISTOWN BLVD

194+12

195+37

W20-7(0)-48

190+64

190+64

150'-0"

G20-1103-6036
END WORK ZONE SPEED LIMIT



MODEL: Harristown Blvd Staging Sheet
FILE NAME: Y:\IDOT\1445-01_74D08\74D08_DESIGN\CADD\Highway\CADD Sheets\ID774D08-shs-staging2.dgn



USER NAME = atn	DESIGNED - ATN	REVISED -
ESCA PROJECT NO. = 1445,01	DRAWN - ATN	REVISED -
PLOT DATE = 9/12/2025	CHECKED - ELH	REVISED -
	DATE - 01/26	REVISED -

STATE OF ILLINOIS
DEPARTMENT OF TRANSPORTATION

HARRISTOWN BOULEVARD
STAGE II TRAFFIC CONTROL PLAN

SCALE: 1" = 20' SHEET 2 OF 3 SHEETS STA. TO STA.

F.A.I. RTE.	SECTION	COUNTY	TOTAL SHEETS	SHEET NO.
72	D7 BRIDGE REPAIRS 2026-3	MACON	108	30
CONTRACT NO. 74D08				
ILLINOIS FED. AID PROJECT				

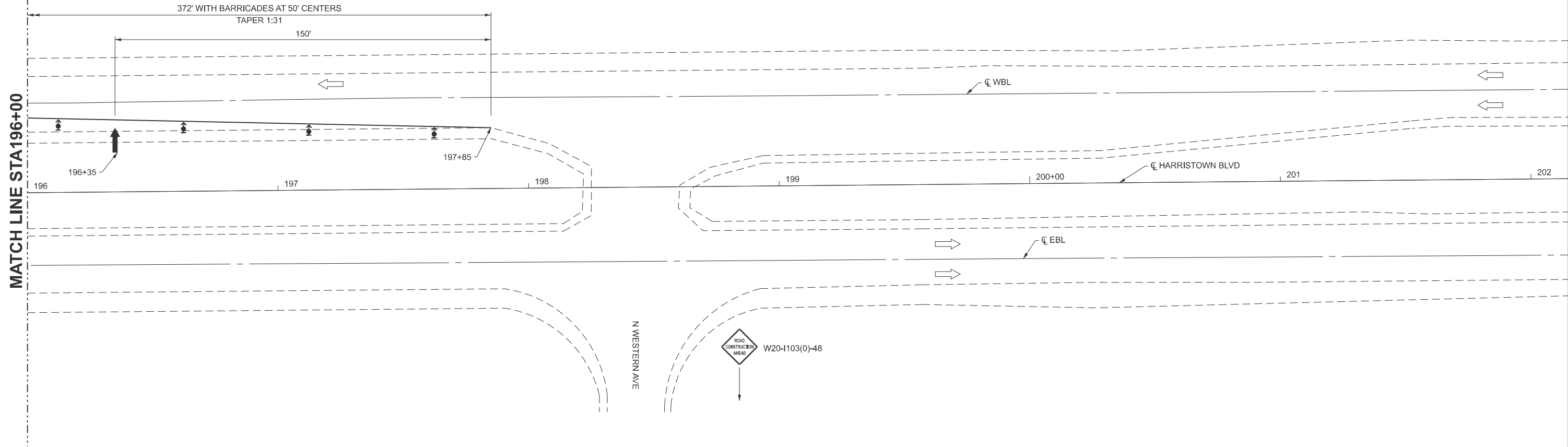

MODEL: Harrisstown Blvd Striping Sheet
 FILE NAME: Y:\IDOT\1445-01_74D08\74D08 DESIGN\CADD\Highway\CADD Sheets\ID774D08-sh1-staging33.dgn



USER NAME = atn	DESIGNED - ATN	REVISED -
ESCA PROJECT NO. = 1445.01	DRAWN - ATN	REVISED -
	CHECKED - ELH	REVISED -
PLOT DATE = 9/10/2025	DATE - 01/26	REVISED -

**STATE OF ILLINOIS
 DEPARTMENT OF TRANSPORTATION**

**HARRISTOWN BOULEVARD
 STAGE II TRAFFIC CONTROL PLAN**

SCALE: 1" = 20' SHEET 3 OF 3 SHEETS STA. TO STA.

F.A.I. RTE.	SECTION	COUNTY	TOTAL SHEETS	SHEET NO.
72	D7 BRIDGE REPAIRS 2026-3	MACON	108	31
CONTRACT NO. 74D08				
ILLINOIS FED. AID PROJECT				

NOTES

1. LOCATIONS OF TRAFFIC CONTROL DEVICES MAY BE ADJUSTED BY THE ENGINEER.
2. SEE STANDARD 701901 FOR ADDITIONAL DETAILS.
3. ALL TRAFFIC CONTROL SHOWN ON THIS SHEET IS INCLUDED IN THE LUMP SUM AMOUNT FOR TRAFFIC CONTROL AND PROTECTION, STANDARD BLR 21.
4. DIMENSIONS FOR ALL SIGNS ARE TO BE 48" UNLESS SPECIFIED OTHERWISE.
5. EACH SIGN SHALL HAVE A FLASHING LIGHT. EACH TYPE III BARRICADE SHALL HAVE TWO FLASHING LIGHTS.

LEGEND

- † SIGN ON PERMANENT SUPPORT
- ⌄ TYPE III BARRICADES WITH FLASHING LIGHTS

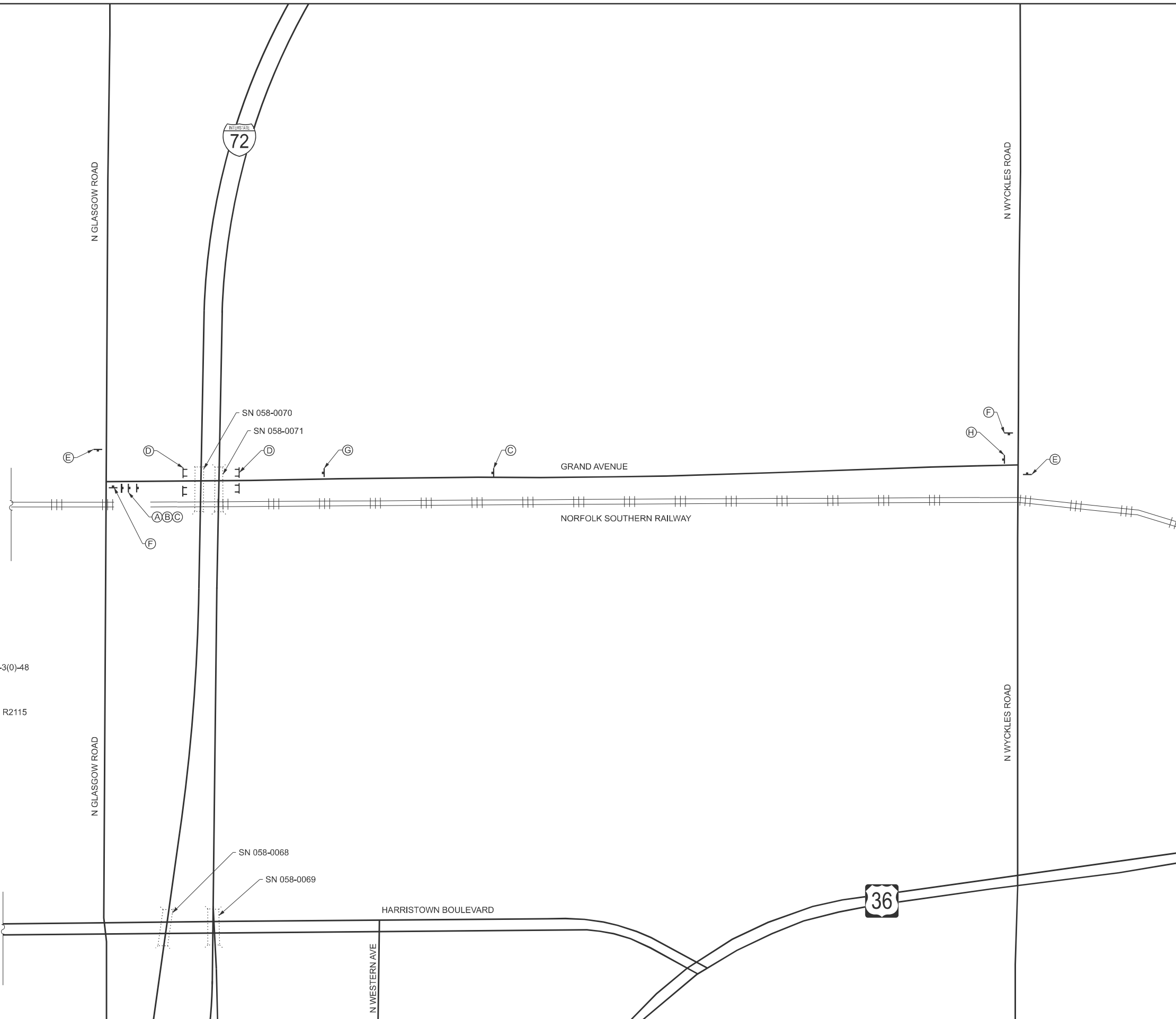
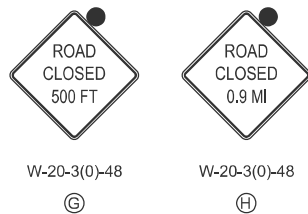
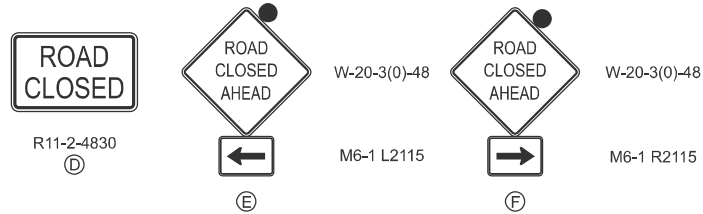
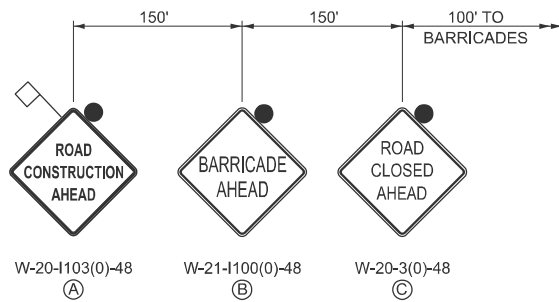

MODEL: Grand Avenue Road Closure Sheet
FILE NAME: Y:\DOT\1445-01_74D08\74D08 DESIGN\CADD\Highway\CADD Sheets\ID774D08-shh-stage\g31.dgn



USER NAME = atn	DESIGNED - ATN	REVISED -
ESCA PROJECT NO. = 1445,01	DRAWN - ATN	REVISED -
PLOT DATE = 9/10/2025	CHECKED - ELH	REVISED -
	DATE - 01/26	REVISED -

**STATE OF ILLINOIS
DEPARTMENT OF TRANSPORTATION**

**GRAND AVENUE
CLOSURE PLAN**

SCALE: NONE SHEET 1 OF 1 SHEETS STA. TO STA.

F.A.I. RTE.	SECTION	COUNTY	TOTAL SHEETS	SHEET NO.
72	D7 BRIDGE REPAIRS 2026-3	MACON	108	32
CONTRACT NO. 74D08				
ILLINOIS FED. AID PROJECT				

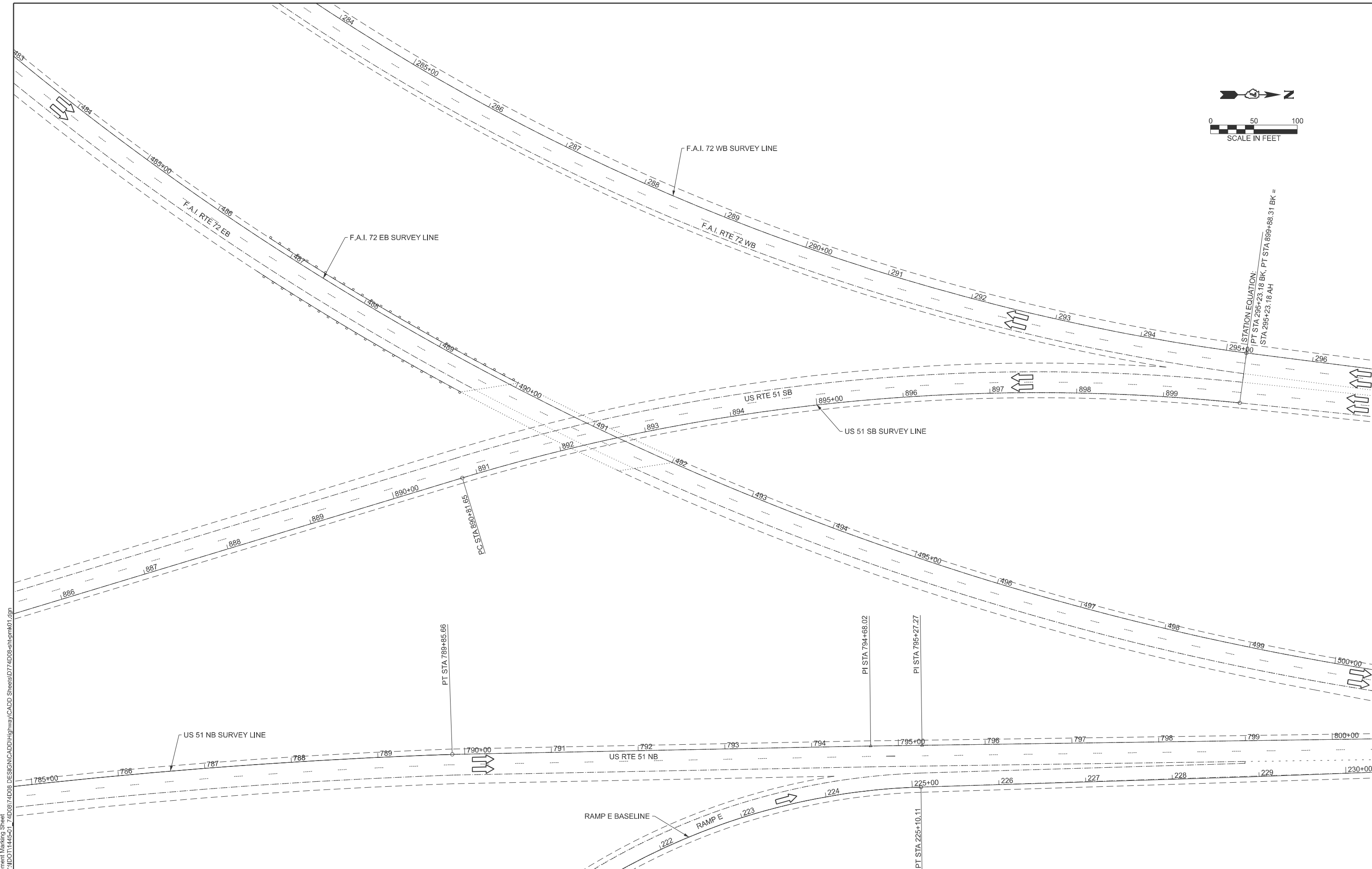
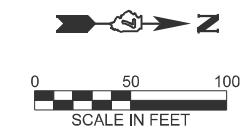

MODEL: Pavement Marking Sheet
 FILE NAME: Y:\DOT\1445-01_74D08\74D08 DESIGN\CADD\Highway\CADD Sheets\74D08-sh1-pmk01.dgn



USER NAME = atn	DESIGNED - ATN	REVISED -
ESCA PROJECT NO. = 1445.01	DRAWN - ATN	REVISED -
PLOT DATE = 9/12/2025	CHECKED - ELH	REVISED -
	DATE - 01/26	REVISED -

STATE OF ILLINOIS
DEPARTMENT OF TRANSPORTATION

I-72
PAVEMENT MARKING PLAN

SCALE: 1" = 50' SHEET 1 OF 4 SHEETS STA. TO STA.

F.A.I. RTE.	SECTION	COUNTY	TOTAL SHEETS	SHEET NO.
72	D7 BRIDGE REPAIRS 2026-3	MACON	108	33
CONTRACT NO. 74D08				
ILLINOIS FED. AID PROJECT				

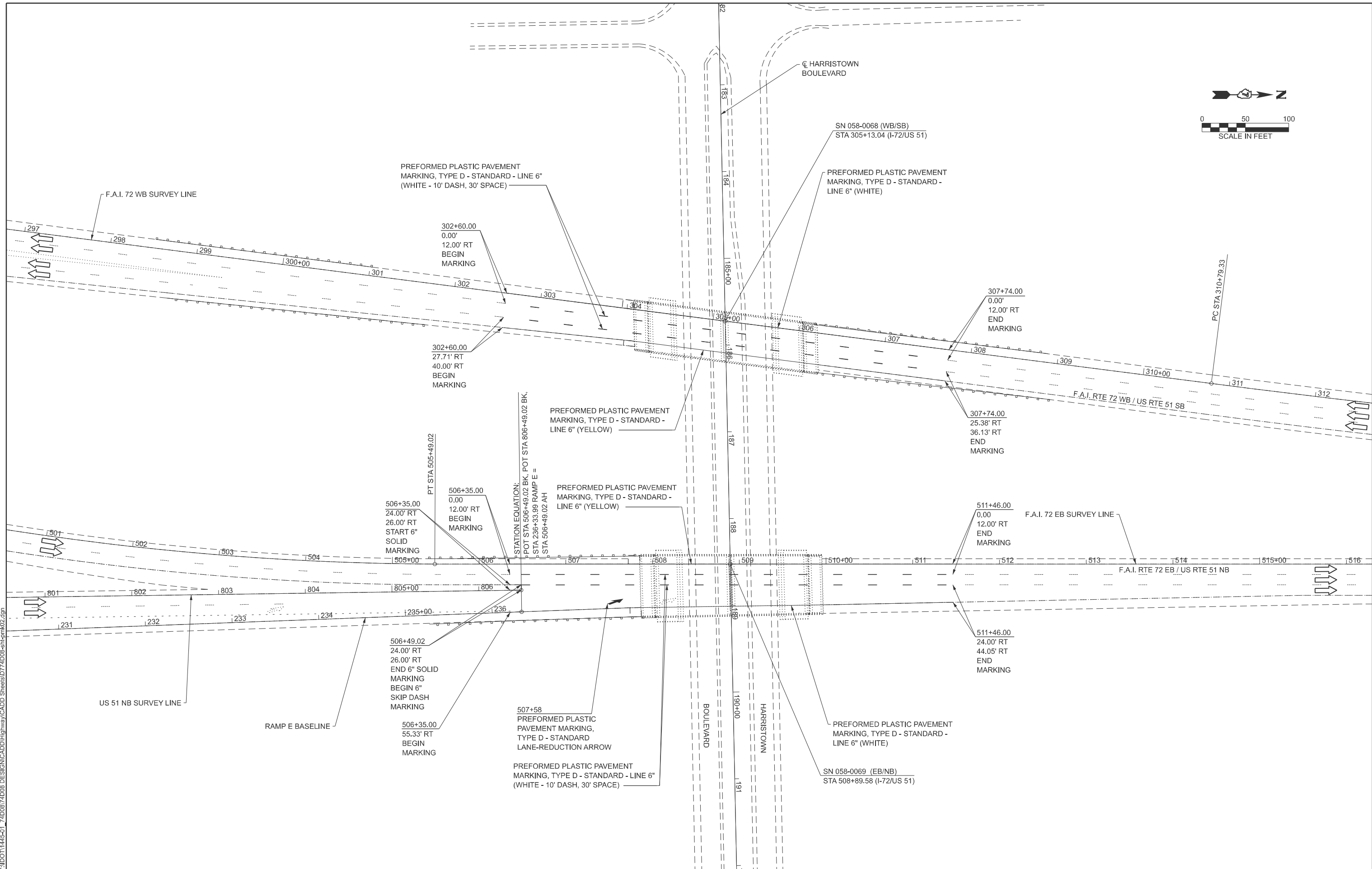
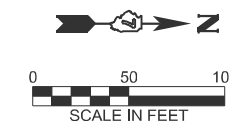

MODEL: Pavement Marking Sheet
FILE NAME: Y:\IDOT\1445-01_74D08\74D08_DESIGN\CADD\Highway\CADD Sheets\74D08-sh1-pmk02.dgn



USER NAME = atn	DESIGNED - ATN	REVISED -
ESCA PROJECT NO. = 1445,01	DRAWN - ATN	REVISED -
PLOT DATE = 7/28/2025	CHECKED - ELH	REVISED -
	DATE - 01/26	REVISED -

**STATE OF ILLINOIS
DEPARTMENT OF TRANSPORTATION**

**I-72
PAVEMENT MARKING PLAN**

SCALE: 1" = 50' SHEET 2 OF 4 SHEETS STA. TO STA.

F.A.I. RTE.	SECTION	COUNTY	TOTAL SHEETS	SHEET NO.
72	D7 BRIDGE REPAIRS 2026-3	MACON	108	34
CONTRACT NO. 74D08				
ILLINOIS FED. AID PROJECT				

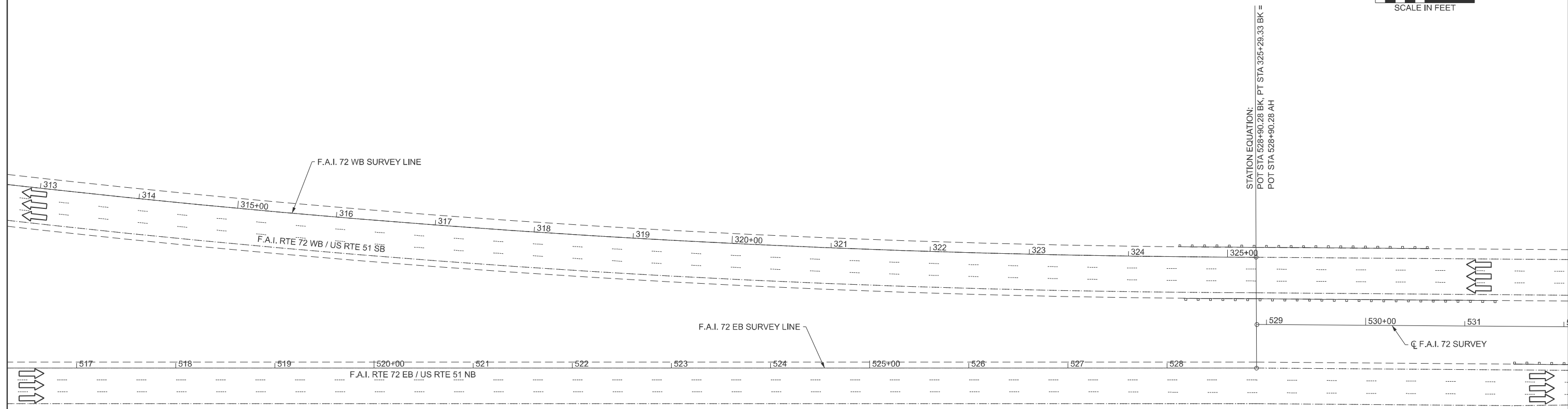
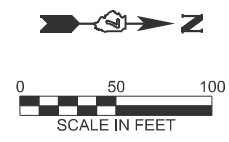

MODEL: Pavement Marking Sheet
 FILE NAME: Y:\DOT\1445-01_74D08\74D08_DESIGN\CADD\Highway\CADD Sheets\ID774D08-shl-pmk03.dgn



USER NAME = atn	DESIGNED - ATN	REVISED -
ESCA PROJECT NO. = 1445.01	DRAWN - ATN	REVISED -
	CHECKED - ELH	REVISED -
PLOT DATE = 7/28/2025	DATE - 01/26	REVISED -

**STATE OF ILLINOIS
 DEPARTMENT OF TRANSPORTATION**

**I-72
 PAVEMENT MARKING PLAN**

SCALE: 1" = 50' SHEET 3 OF 4 SHEETS STA. TO STA.

F.A.I. RTE.	SECTION	COUNTY	TOTAL SHEETS	SHEET NO.
72	D7 BRIDGE REPAIRS 2026-3	MACON	108	35
CONTRACT NO. 74D08				
ILLINOIS FED. AID PROJECT				

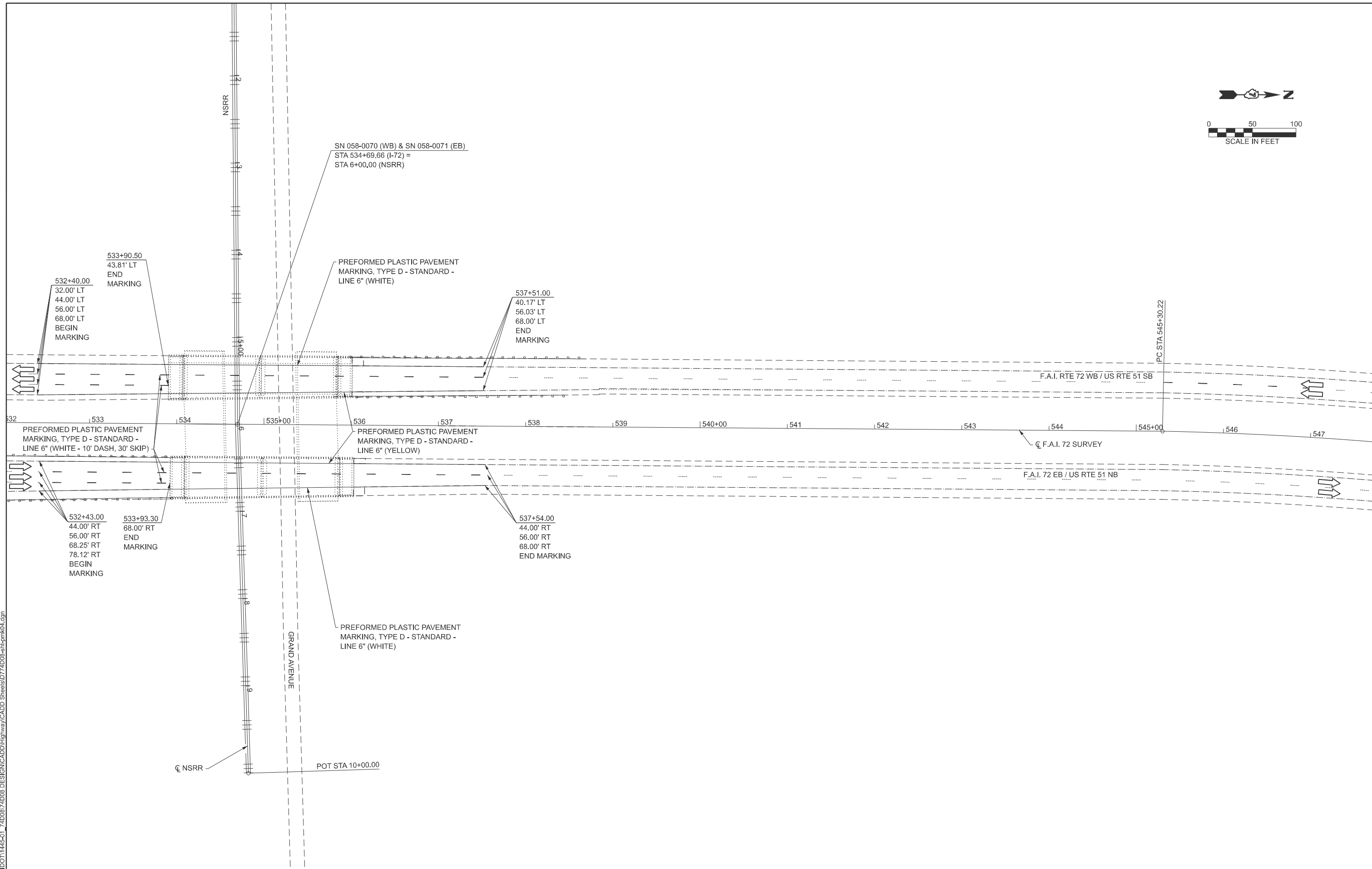

MODEL: Pavement Marking Sheet
 FILE NAME: Y:\DOT\1445-01_74D08\74D08_DESIGN\CADD\Highway\CADD Sheets\I72\74D08-sh1-pmk04.dgn



USER NAME = atn	DESIGNED - ATN	REVISED -
ESCA PROJECT NO. = 1445,01	DRAWN - ATN	REVISED -
PLOT DATE = 9/17/2025	CHECKED - ELH	REVISED -
	DATE - 01/26	REVISED -

**STATE OF ILLINOIS
DEPARTMENT OF TRANSPORTATION**

I-72 PAVEMENT MARKING PLAN		F.A.I. RTE.	SECTION	COUNTY	TOTAL SHEETS	SHEET NO.
		72	D7 BRIDGE REPAIRS 2026-3	MACON	108	36
SCALE: 1" = 50'		SHEET 4 OF 4 SHEETS		STA. TO STA.		CONTRACT NO. 74D08

ILLINOIS		FED. AID PROJECT	
----------	--	------------------	--

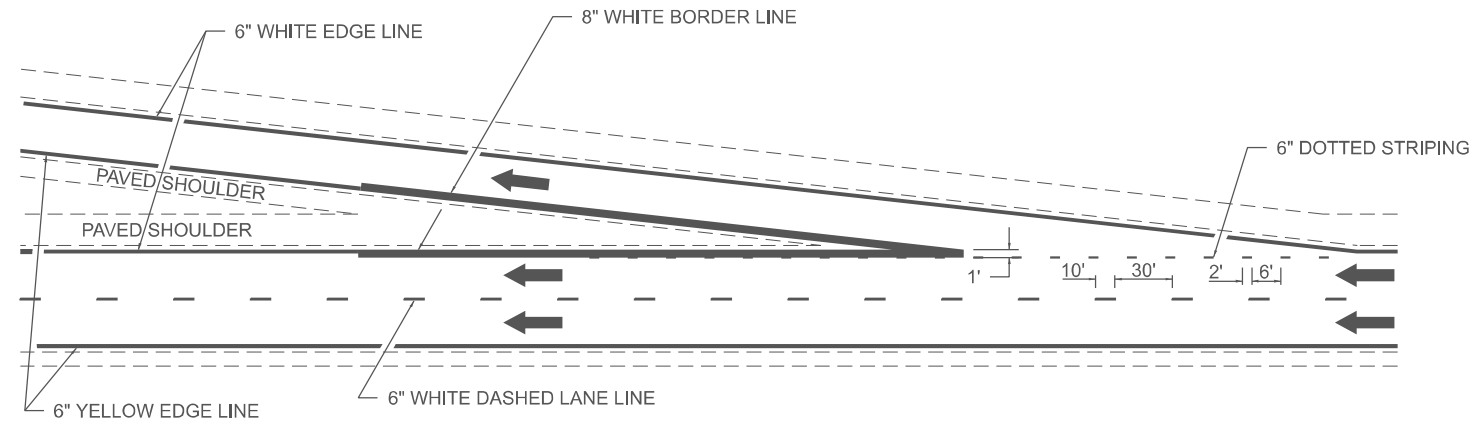

TYPICAL EXIT RAMP MARKING

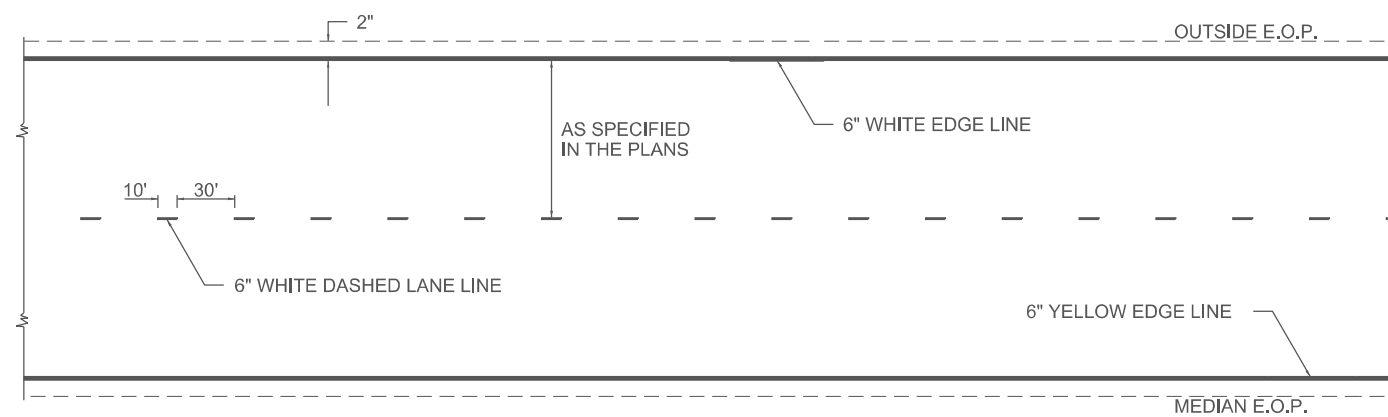

TYPICAL CENTERLINE & EDGELINE MARKINGS

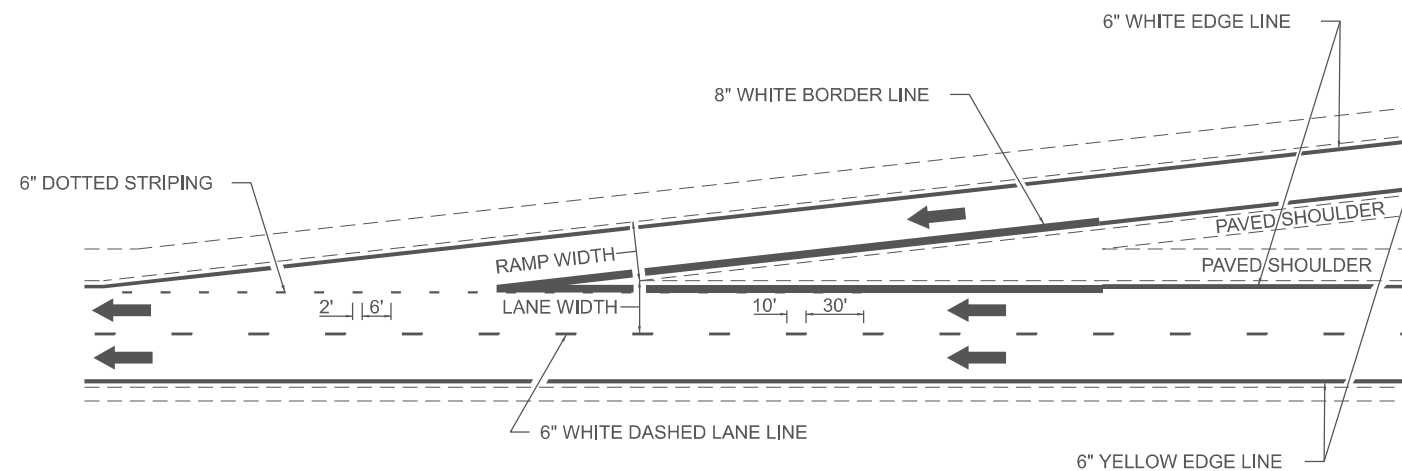

TYPICAL ENTRANCE RAMP MARKING

NOT TO SCALE

DISTRICT 7 DETAIL NO. 7800002

F.A.I. RTE.	SECTION	COUNTY	TOTAL SHEETS	SHEET NO.
72	D7 BRIDGE REPAIRS 2026-3	MACON	108	37
CONTRACT NO. 74D08				
ILLINOIS FED. AID PROJECT				

STATE OF ILLINOIS
DEPARTMENT OF TRANSPORTATION

TYPICAL APPLICATIONS OF INTERSTATE PAVEMENT MARKINGS

SCALE: NONE SHEET 1 OF 2 SHEETS STA. TO STA.

USER NAME = atn	DESIGNED - ATN	REVISED -
ESCA PROJECT NO. = 1445.01	DRAWN - ATN	REVISED -
	CHECKED - ELH	REVISED -
PLOT DATE = 1/15/2026	DATE - 01/26	REVISED -



MODEL: Details Sheet
FILE NAME: Y:\DOT\1445-01_74D08\74D08 DESIGN\CADD\Highway\CADD Sheets\ID774D08-sh1-details01.dgn

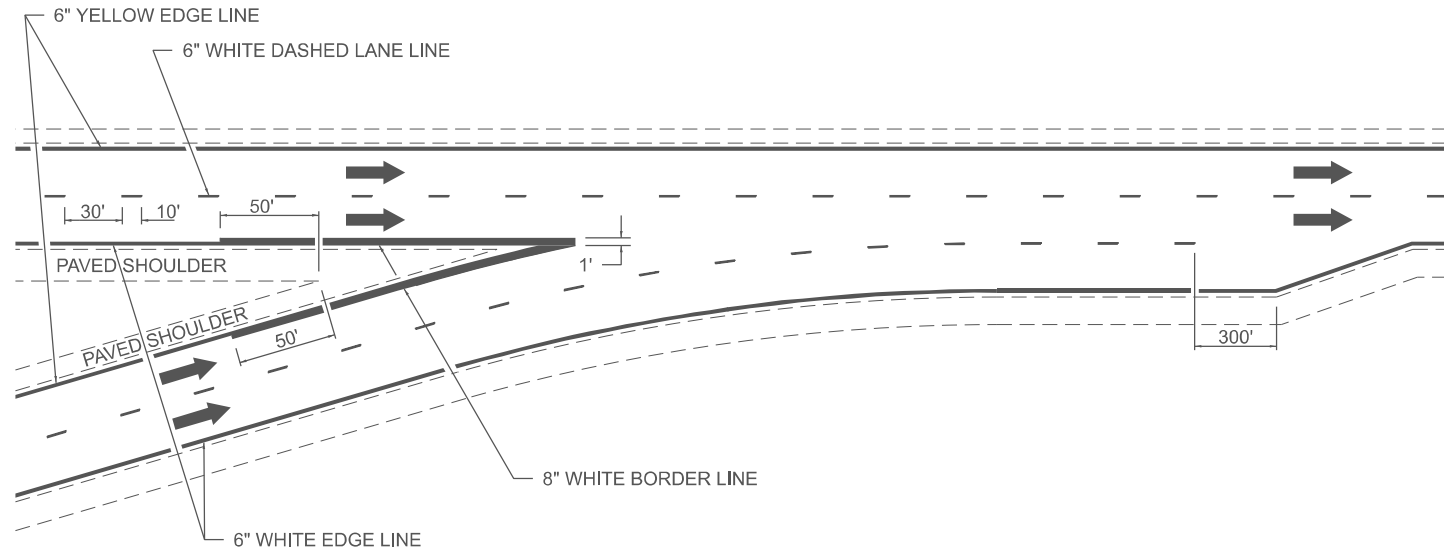

TYPICAL CONVERGENCE MARKING

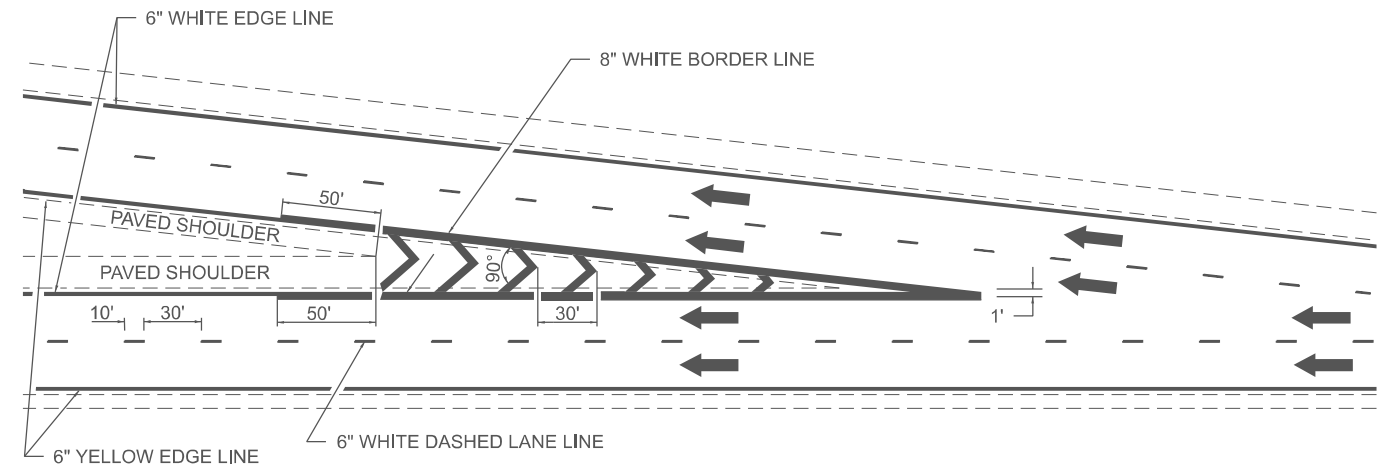

TYPICAL DIVERGENCE MARKING

AERIAL SPEED CHECK ZONES

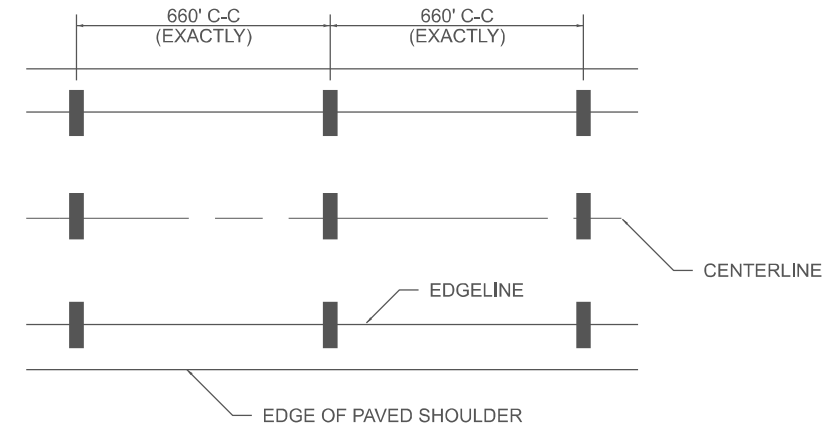

IT WILL BE NECESSARY TO HAVE A REPRESENTATIVE OF THE STATE POLICE PRESENT SO THAT THE ACCURACY OF MEASUREMENT CAN BE ATTESTED TO IN COURT.

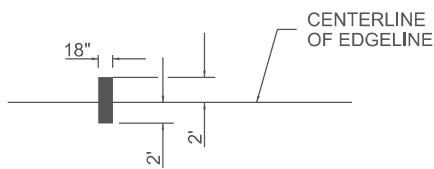

NOT TO SCALE

DISTRICT 7 DETAIL NO. 7800002

F.A.I. RTE.	SECTION	COUNTY	TOTAL SHEETS	SHEET NO.
72	D7 BRIDGE REPAIRS 2026-3	MACON	108	38
CONTRACT NO. 74D08				
ILLINOIS FED. AID PROJECT				

MODEL: Details Sheet
FILE NAME: Y:\DOT\1445-01_74D08\74D08_DESIGN\CADD\Highway\CADD Sheets\ID774D08-sh1-details02.dgn



USER NAME = atn	DESIGNED - ATN	REVISED -
ESCA PROJECT NO. = 1445.01	DRAWN - ATN	REVISED -
PLOT DATE = 12/8/2025	CHECKED - ELH	REVISED -
	DATE - 01/26	REVISED -

STATE OF ILLINOIS
DEPARTMENT OF TRANSPORTATION

TYPICAL APPLICATIONS OF INTERSTATE PAVEMENT MARKINGS

SCALE: NONE SHEET 2 OF 2 SHEETS STA. TO STA.

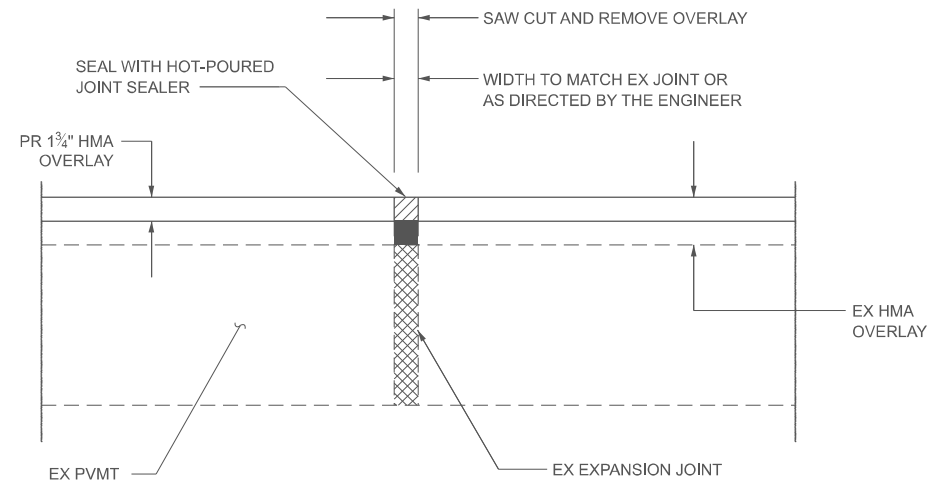

EXPANSION JOINT REHABILITATION DETAIL

NOTES:

1. THE NEW HMA INLAY SHALL BE SAWED, REMOVED, AND THE JOINT AREA CLEANED, PRIOR TO PLACING THE HOT-POURED JOINT SEALER, THE JOINT SHALL BE BLOWN OUT WITH COMPRESSED AIR.

MODEL: Details Sheet
 FILE NAME: Y:\DOT\1445-01_74D08\74D08 DESIGN\CADD\Highway\CADD Sheets\ID774D08-shr-details03.dgn



USER NAME = atn	DESIGNED - ATN	REVISED -
ESCA PROJECT NO. = 1445.01	DRAWN - ATN	REVISED -
	CHECKED - ELH	REVISED -
PLOT DATE = 1/15/2026	DATE - 01/26	REVISED -

**STATE OF ILLINOIS
DEPARTMENT OF TRANSPORTATION**

MISCELLANEOUS DETAILS

SCALE: NONE SHEET 1 OF 1 SHEETS STA. TO STA.

F.A.I. RTE.	SECTION	COUNTY	TOTAL SHEETS	SHEET NO.
72	D7 BRIDGE REPAIRS 2026-3	MACON	108	39
CONTRACT NO. 74D08				
ILLINOIS FED. AID PROJECT				

EXISTING STRUCTURE:

The existing four-span structures were constructed in 1976 as F.A.I. 72 Section 58-62HB-4 at Stations 305+13.04 and 508+89.58. SN 058-0068 carries I-72 Westbound over Harristown Boulevard. SN 058-0069 carries I-72 Eastbound over Harristown Boulevard. In 2006, deck patching was performed and the bituminous wearing surfaces were replaced with microsilica concrete overlays. After that, the expansion joints were replaced at SN 058-0069. The end spans are reinforced concrete slabs, and the main spans are steel welded plate girders. The concrete vaulted abutments and pile bents are supported on concrete piles, and the piers are also supported on concrete piles. SN 058-0068 is 213'-9" back-to-back of bent caps, 58'-0" out-to-out, and is skewed 8°-44'-10" right forward. SN 058-0069 is 210'-5" back-to-back of bent caps, is tapered from 69'-0½" to 73'-2⅞" out-to-out, and is skewed 1°-29'-02" right forward.

The proposed project consists of bridge deck repairs, new concrete overlays, new bearings at the abutments, substructure repairs, and slope wall repairs. Traffic on I-72 is to be maintained utilizing stage construction. Lane closures will be used on Harristown Blvd. as necessary.

SCOPE OF WORK

1. Replace bearings at abutments.
2. Replace expansion joints at abutments with Preformed Joint Strip Seal.
3. Perform Bridge Deck Scarification 2¼".
4. Perform Deck Slab Repair.
5. Replace existing deck drains with 6" diameter Floor Drains.
6. Construct new 2½" concrete overlays.
7. Perform Diamond Grinding (Bridge Section).
8. Perform Bridge Deck Grooving (Longitudinal).
9. Apply Protective Coat.
10. Construct parapet and substructure repairs.
11. Raise crashwall elevation at piers.
12. Repair slope walls.

STRUCTURE INDEX OF SHEETS

General Plan & Elevation	Sheet No. 1 of 33
General Data	Sheet No. 2 of 33
Stage Construction	Sheet No. 3-4 of 33
Temporary Concrete Barrier	Sheet No. 5 of 33
Bridge Deck Patching	Sheet No. 6-7 of 33
Expansion Joint Replacement Details	Sheet No. 8-12 of 33
Deck Drain Details	Sheet No. 13 of 33
Preformed Joint Strip Seal	Sheet No. 14 of 33
Bearing Details	Sheet No. 15-16 of 33
Parapet Repairs	Sheet No. 17-20 of 33
Abutment Repairs	Sheet No. 21-22 of 33
Pier Repairs	Sheet No. 23-24 of 33
Slope Wall Repairs	Sheet No. 25-26 of 33
Bar Splicer Assembly and Mechanical Splicer Details	Sheet No. 27 of 33
Existing Bridge Plans	Sheet No. 28-33 of 33

DESIGN SPECIFICATIONS (new const.)

2002 AASHTO Standard Specifications for Highway Bridges, 17th Edition

LOADING HS20-44 & ALTERNATE (new const.)

No allowance for future wearing surface

DESIGN STRESSES

FIELD UNITS
EXISTING CONSTRUCTION
 fc = 1,400 psi (substructure, curbs, parapets, & approach slabs)
 fc = 1,200 psi (superstructure slab)
 fs = 20,000 psi (reinforcement)

NEW CONSTRUCTION
 fc = 4,000 psi (concrete)
 fy = 60,000 psi (reinforcement)
 fy = 36,000 psi (structural steel)

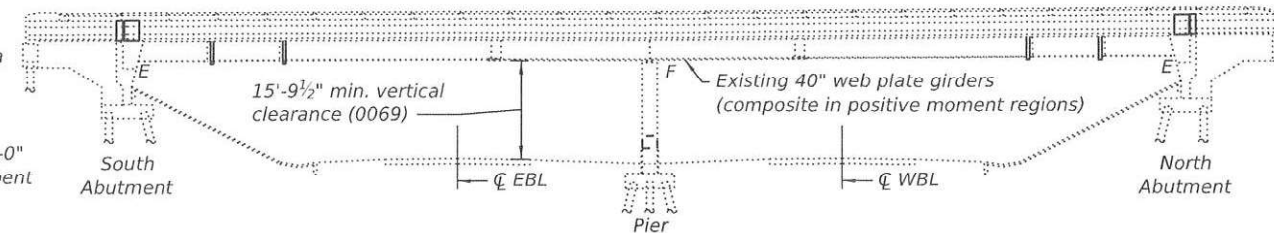

ELEVATION

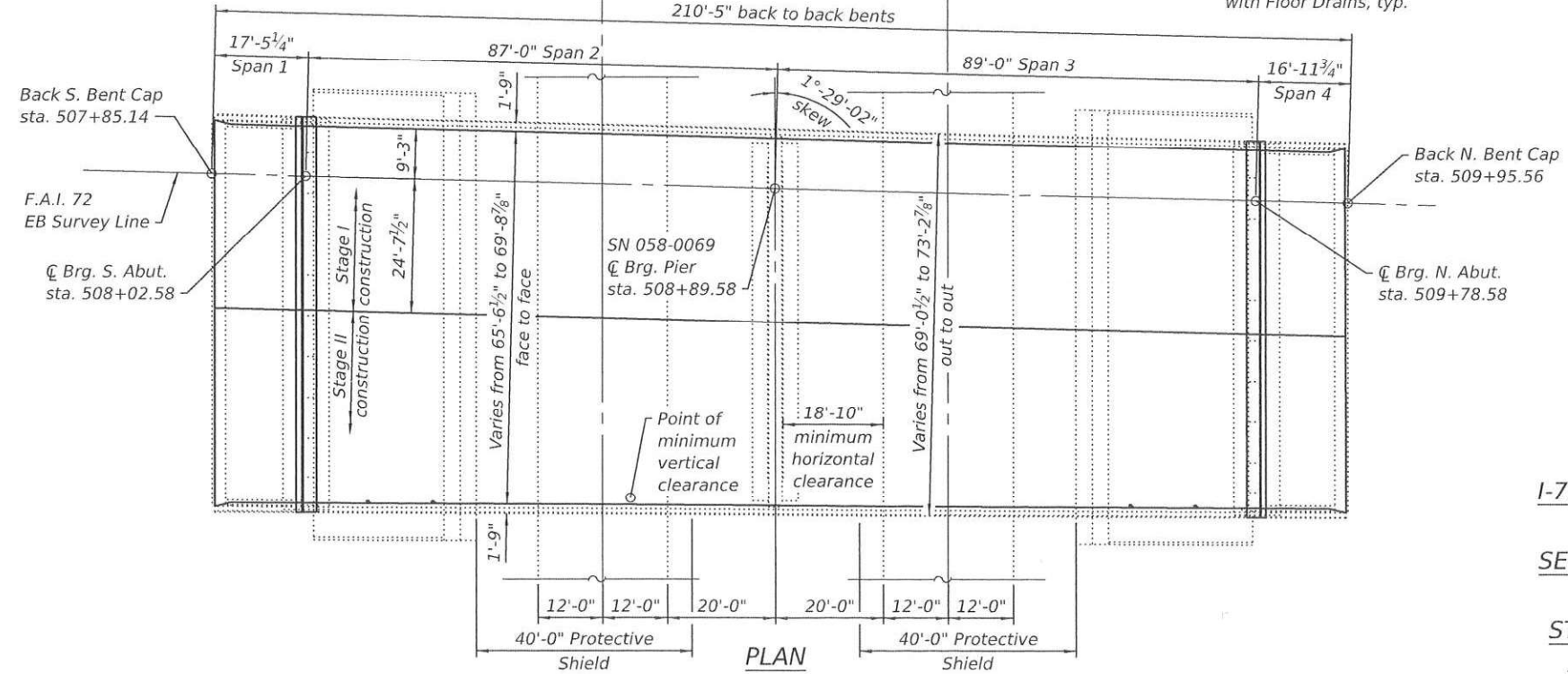
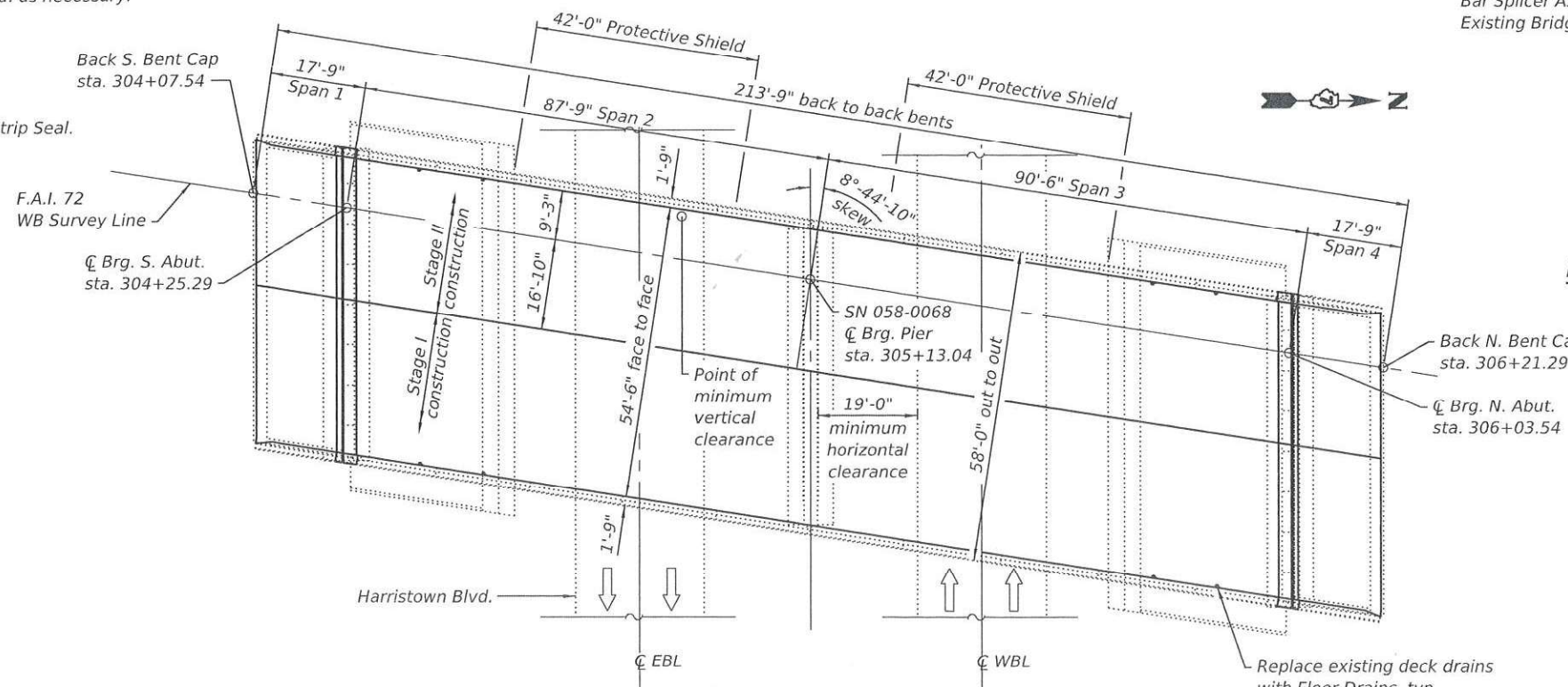

PLAN

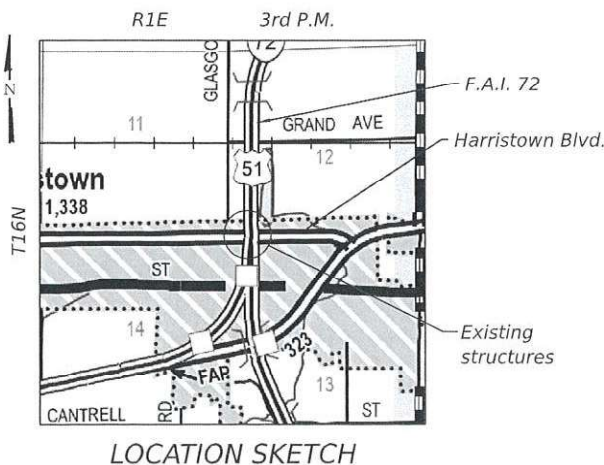

LOCATION SKETCH

STATE OF ILLINOIS
 No. 081-006159
 EXPIRES 11-30-26
 SIGNATURE
 01-22-26
 DATE

GENERAL PLAN & ELEVATION
I-72/US 51 OVER HARRISTOWN BLVD.
F.A.I. ROUTE 72
SECTION D7 BRIDGE REPAIRS 2026-3
MACON COUNTY
STATIONS 305+13.04 & 508+89.58
STRUCTURE NO. 058-0068/0069

MODEL: Sheet FILE NAME: Y:\DOT\1445-01_74D08\74D08.DESIGN\CADD\SP_SN 058-0068-0069\Common sheets\0580068-D774D08-01-GPE.dgn 1/20/2026 10:00:32 AM



USER NAME = nhc	DESIGNED - ELH 07/25	REVISED -
ESCA PROJECT NO. = 1445.01	CHECKED - RDP 07/25	REVISED -
PLOT SCALE = 0.2" / in.	DRAWN - NHC 01/26	REVISED -
PLOT DATE = 1/20/2026	CHECKED - ELH 01/26	REVISED -

STATE OF ILLINOIS
 DEPARTMENT OF TRANSPORTATION

F.A.I. RTE.	SECTION	COUNTY	TOTAL SHEETS	SHEET NO.
72	D7 BRIDGE REPAIRS 2026-3	MACON	108	40
CONTRACT NO. 74D08				
ILLINOIS FED. AID PROJECT				

GENERAL NOTES

1. Reinforcement bars designated (E) shall be epoxy coated.
2. Plan dimensions and details relative to the existing structures have been taken from existing plans and are subject to nominal construction variations. The Contractor shall field verify existing dimensions and details affecting new construction and make necessary approved adjustments prior to construction or ordering of materials. Such variations shall not be cause for additional compensation for a change in scope of work; however, the Contractor will be paid for the quantity actually furnished at the unit price bid for the work.
3. Existing reinforcement bars extending into the removal area shall be cleaned, straightened, and incorporated into the new construction. Cost included in Concrete Removal. Any reinforcement bars that are damaged during concrete removal shall be replaced with an approved bar splicer or anchorage system at the Contractor's expense.
4. Areas of deck repairs shown are estimated. The Engineer shall show actual locations and size of deck repairs on As-Built Plans.
5. The existing structural steel coating contains lead. The existing bearings contain lead plates. The Contractor shall take appropriate precautions to deal with the presence of lead on this project.
6. No field welding is permitted except as specified in the contract documents.
7. Prior to pouring the new concrete deck, all heavy or loose rust, loose mill scale, and other loose detrimental foreign material shall be removed from the surfaces in contact with concrete (SSPC-SP3 standards). Tightly adhered paint may remain unless otherwise noted. Removal shall be accomplished by methods that will not damage the steel and the cost will be included in Concrete Removal.
8. The cost of deck drains to be removed is included in Deck Slab Repair.
9. All new structural steel extensions, bearing assemblies, and shim plates shall be hot dip galvanized. See special provision for "Hot Dip Galvanizing for Structural Steel."
10. Joint openings shall be adjusted according to Article 520.04 of the Std. Specs. when the deck is poured at an ambient temperature other than 50° F.
11. Removal and reinstallation of the handrail sections and support posts at both abutments will be necessary for construction of the expansion joints. The existing handrail sections and support posts shall be reused. New bolts, shim plates, and post support anchor assemblies, as detailed in the existing plans, are to be provided and installed for the replacement of the handrail sections. This work and all materials shall be included in the contract unit price for Concrete Superstructure.
12. Full depth deck slab repairs performed in the exterior bays of the bridge deck (between the parapet walls and the first interior beams) shall be limited to individual lengths no greater than 10'. In these portions of the deck, repair areas longer than 10' shall be divided into segments not greater than 10' in length, and the segments shall be poured in alternating sequence. Subsequent segments repaired in sequence shall not be removed until 72 hours have elapsed from the end of the previous, adjacent pour, and the adjacent pour shall have attained a minimum modulus of rupture of 650 psi.
13. Protective Coat shall be applied to areas of Concrete Superstructure consisting of the front faces and tops of the parapets and the expansion joint concrete. Protective Coat shall also be applied to the tops of the new concrete overlays and new portions of concrete slope walls.
14. Up to ¼ inch is to be ground off the proposed concrete overlays.
15. The quantities and locations of Structural Repair of Concrete are approximated. Actual quantities and locations are to be determined in the field by the Engineer. This work is intended to repair only areas of severe deterioration. Some minor deteriorated areas may be left unrepaired. Do not disturb the bearings during the repair of adjacent concrete areas.
16. Existing structural steel that will be in contact with new structural steel shall be cleaned and painted prior to erection as required by the Special Provision "Cleaning and Painting Contact Surface Areas of Existing Steel Structures" and the Standard Specifications. Cost is included with Furnishing and Erecting Structural Steel.
17. All structural steel shall conform to AASHTO Classification M-270 Gr. 36, unless otherwise noted.

TOTAL BILL OF MATERIAL

ITEM	UNIT	SN 058-0068	SN 058-0069	TOTAL
Removal and Disposal of Unsuitable Material	Cu. Yd.	15	22	37
Subbase Granular Material, Type B	Ton	30	45	75
Concrete Removal	Cu. Yd.	16.2	18.8	35.0
Protective Shield	Sq. Yd.	542	633	1,175
Floor Drains	Each	8	4	12
Concrete Structures	Cu. Yd.	7.0	8.7	15.7
Concrete Superstructure	Cu. Yd.	15.7	18.8	34.5
Protective Coat	Sq. Yd.	1,366	1,665	3,031
Furnishing and Erecting Structural Steel	Pound	3,597	4,490	8,087
Reinforcement Bars, Epoxy Coated	Pound	2,870	3,860	6,730
Bar Splicers	Each	20	20	40
Preformed Joint Strip Seal	Foot	114.5	139.5	254
Elastomeric Bearing Assembly, Type I	Each	16	20	36
Anchor Bolts, 1"	Each	28	36	64
Bridge Deck Grooving (Longitudinal)	Sq. Yd.	851	1,144	1,995
Slope Wall Repair	Sq. Yd.	66	82	148
Slope Wall Slurry Pumping	Cu. Yd.	20	5	25
Jack and Remove Existing Bearings	Each	16	20	36
Bridge Deck Fly Ash or GGBF Slag Concrete Overlay, 2½"	Sq. Yd.	1,244	1,519	2,763
Bridge Deck Scarification 2¼"	Sq. Yd.	1,244	1,519	2,763
Structural Repair of Concrete (Depth Equal to or Less Than 5 Inches)	Sq. Ft.	274.9	263.9	538.8
Deck Slab Repair (Full Depth, Type I)	Sq. Yd.	10	11	21
Deck Slab Repair (Full Depth, Type II)	Sq. Yd.	65	145	210
Diamond Grinding (Bridge Section)	Sq. Yd.	1,194	1,482	2,676

MODEL: Sheet
FILE NAME: Y:\DOT1445-01_74D08\74D08 DESIGN\CADD\SP SN 058-0068-0069\Common sheets\0580068-D774D08-02-GenNotes.dgn



USER NAME = nhc	DESIGNED - ELH 01/26	REVISED -
ESCA PROJECT NO. = 1445.01	CHECKED - RDP 01/26	REVISED -
PLOT SCALE = 0:2 " = 1" / in.	DRAWN - NHC 01/26	REVISED -
PLOT DATE = 1/20/2026	CHECKED - ELH 01/26	REVISED -

**STATE OF ILLINOIS
DEPARTMENT OF TRANSPORTATION**

**GENERAL DATA
SN 058-0068 (WB) & SN 058-0069 (EB)**

SHEET 2 OF 33 SHEETS

F.A.I. RTE.	SECTION	COUNTY	TOTAL SHEETS	SHEET NO.
72	D7 BRIDGE REPAIRS 2026-3	MACON	108	41
CONTRACT NO. 74D08				
		ILLINOIS	FED. AID PROJECT	

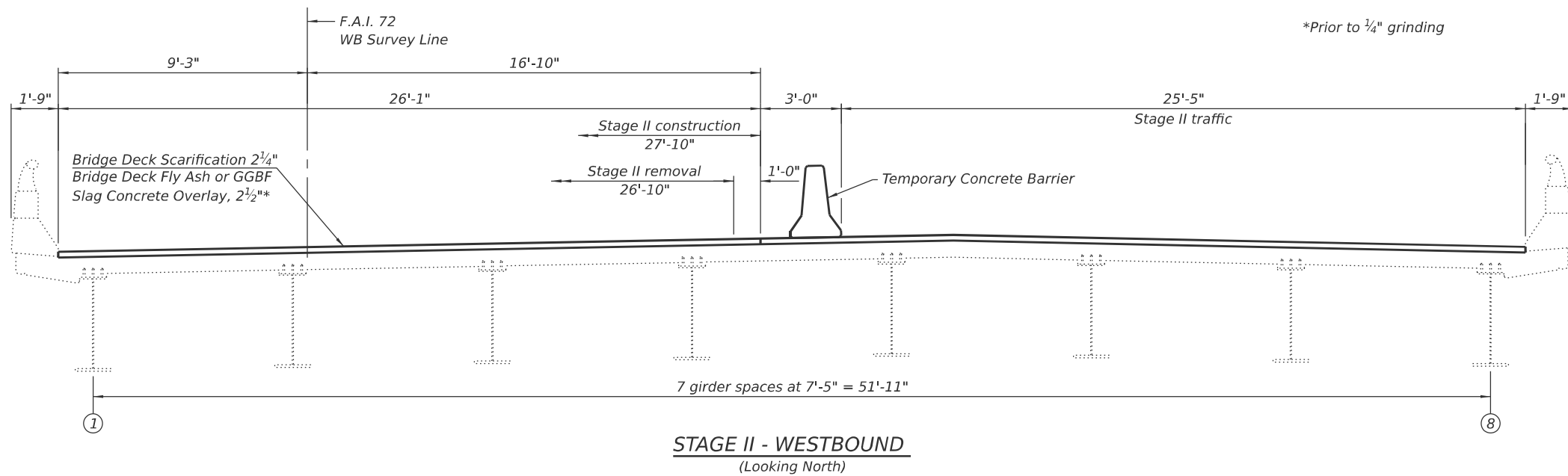
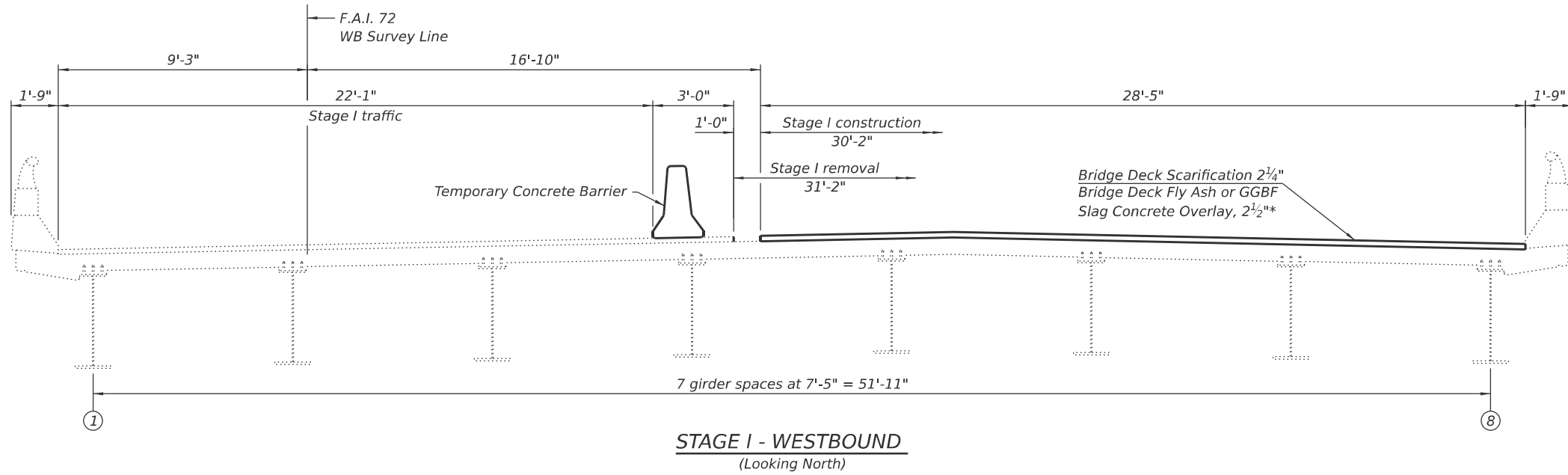

*Prior to 1/4" grinding

MODEL: Sheet
FILE NAME: Y:\IDOT\1445-01_74D08\74D08 DESIGN\CADD\SP SN 058-0068-0069\Common sheets\0580068-D774D08-03-StageCont(WB).dgn

(Sheet 1 of 2)



USER NAME = nhc	DESIGNED - ELH 07/25	REVISED -
ESCA PROJECT NO. = 1445.01	CHECKED - RDP 07/25	REVISED -
PLOT SCALE = 0.2" / in.	DRAWN - NHC 01/26	REVISED -
PLOT DATE = 1/20/2026	CHECKED - ELH 01/26	REVISED -

STATE OF ILLINOIS
DEPARTMENT OF TRANSPORTATION

STAGE CONSTRUCTION
SN 058-0068 (WB)

SHEET 3 OF 33 SHEETS

F.A.I. RTE.	SECTION	COUNTY	TOTAL SHEETS	SHEET NO.
72	D7 BRIDGE REPAIRS 2026-3	MACON	108	42
CONTRACT NO. 74D08				
ILLINOIS FED. AID PROJECT				

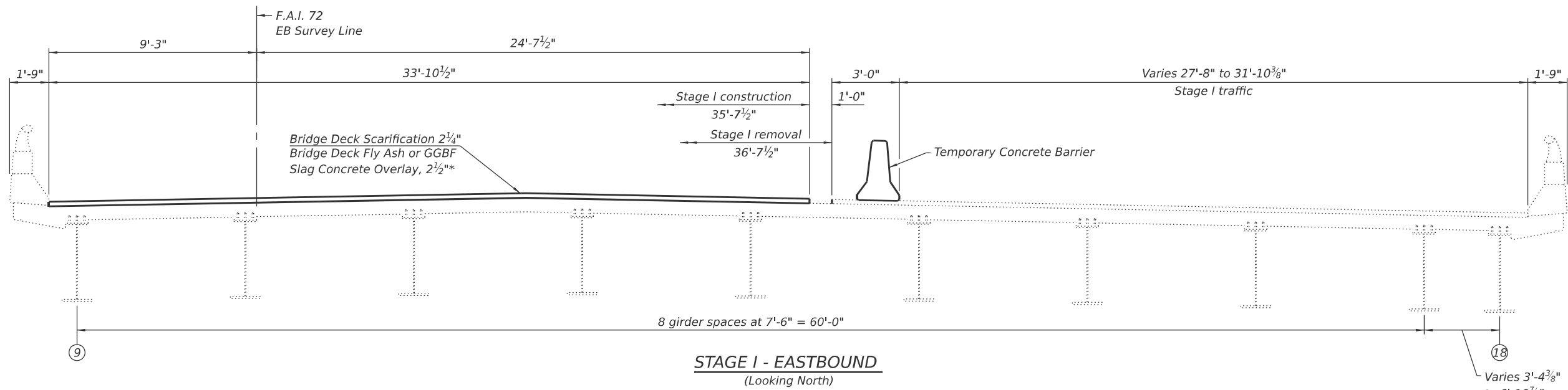

STAGE I - EASTBOUND
(Looking North)

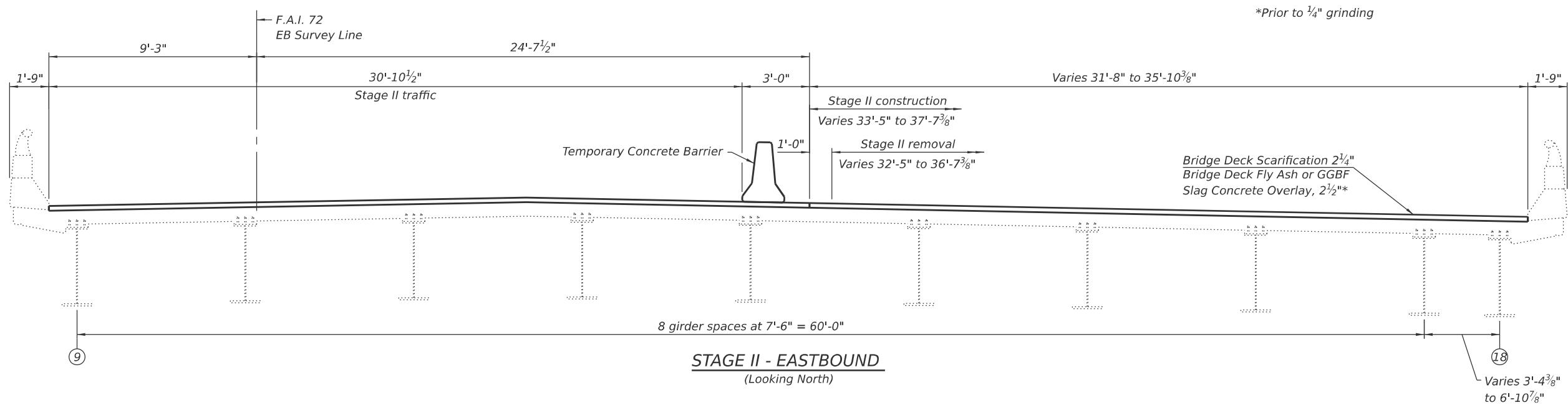

STAGE II - EASTBOUND
(Looking North)

MODEL: Sheet
FILE NAME: Y:\DOT1445-01_74D0874D08 DESIGN\CADD\SP_SN_058-0068-0069\Common sheets\0580068-D774D08-04-StageCont(EB).dgn

(Sheet 2 of 2)



USER NAME = nhc	DESIGNED - ELH 07/25	REVISED -
ESCA PROJECT NO. = 1445.01	CHECKED - RDP 07/25	REVISED -
PLOT SCALE = 0.2" / in.	DRAWN - NHC 01/26	REVISED -
PLOT DATE = 1/20/2026	CHECKED - ELH 01/26	REVISED -

STATE OF ILLINOIS
DEPARTMENT OF TRANSPORTATION

STAGE CONSTRUCTION
SN 058-0069 (EB)

SHEET 4 OF 33 SHEETS

F.A.I. RTE.	SECTION	COUNTY	TOTAL SHEETS	SHEET NO.
72	D7 BRIDGE REPAIRS 2026-3	MACON	108	43
CONTRACT NO. 74D08				
ILLINOIS FED. AID PROJECT				

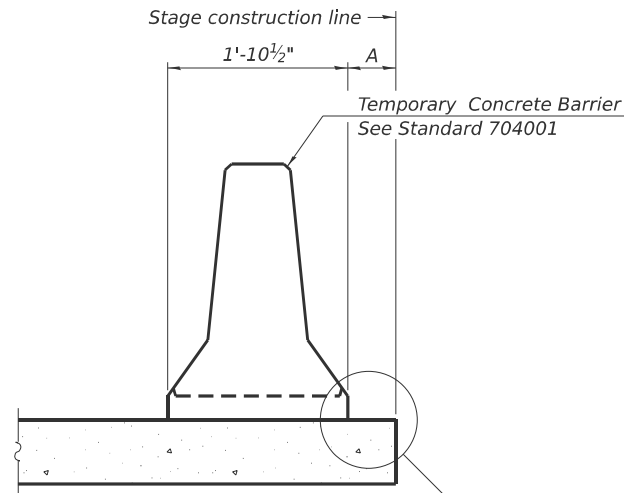

When "A" is 3'-1" or less, the temporary concrete barrier shall be restrained to the new slab according to Detail I, II or III. No restraint is required when "A" is greater than 3'-1".

NEW SLAB OR NEW DECK BEAM

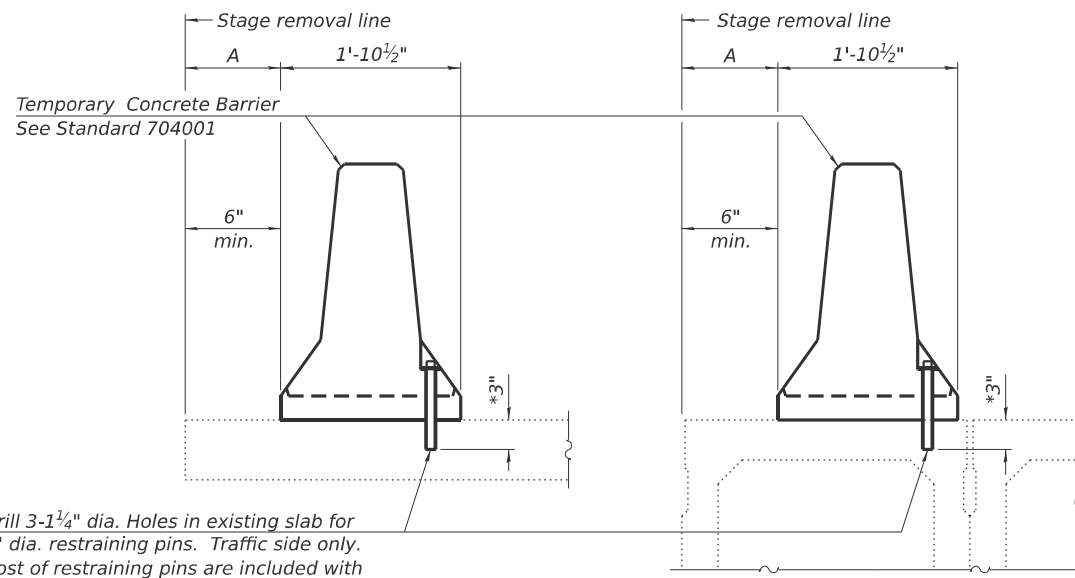

Drill 3-1/4" dia. Holes in existing slab for 1" dia. restraining pins. Traffic side only. Cost of restraining pins are included with Temporary Concrete Barrier. No restraint is required when "A" is greater than 3'-1".

EXISTING SLAB

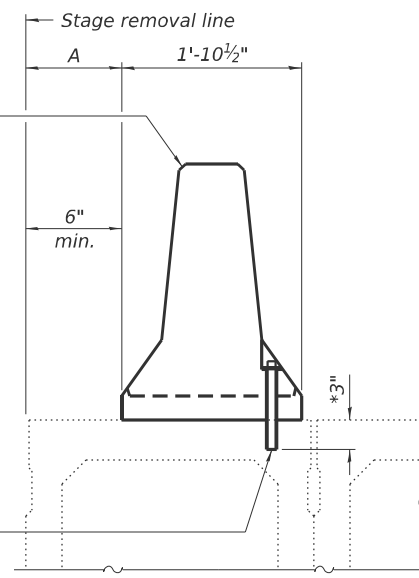

* When hot-mix asphalt wearing surface is present, embedment shall be 3" plus the wearing surface depth.

EXISTING DECK BEAM

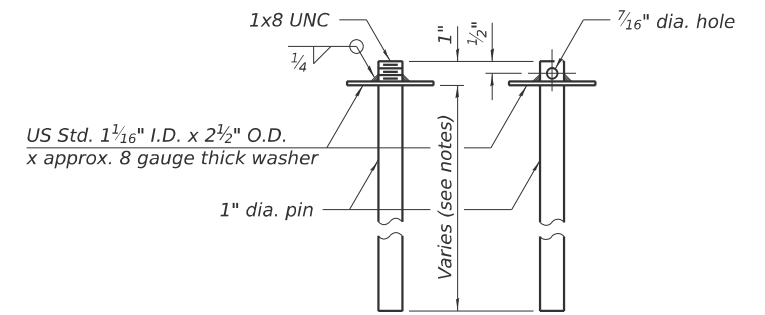

RESTRAINING PIN

SECTIONS THRU SLAB OR DECK BEAM

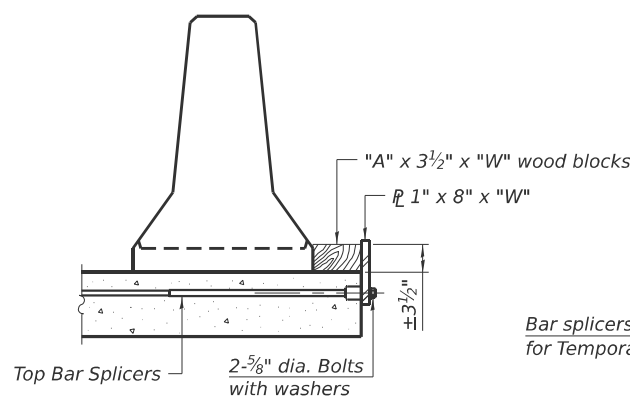

DETAIL I

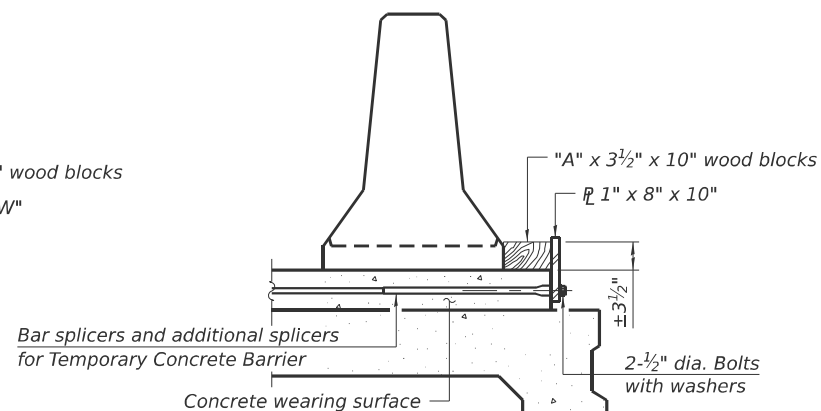

DETAIL II

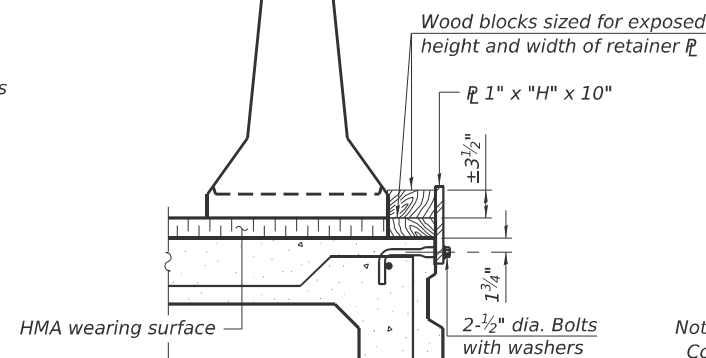

DETAIL III

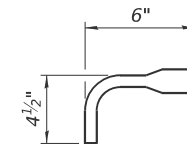

BAR SPLICER FOR #4 BAR - DETAIL III

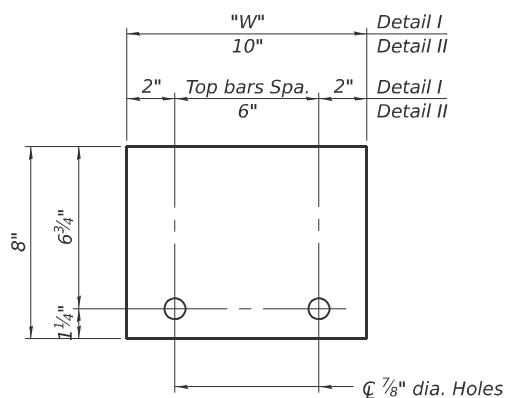

STEEL RETAINER R 1" x 8" x "W"
(Detail I and II)

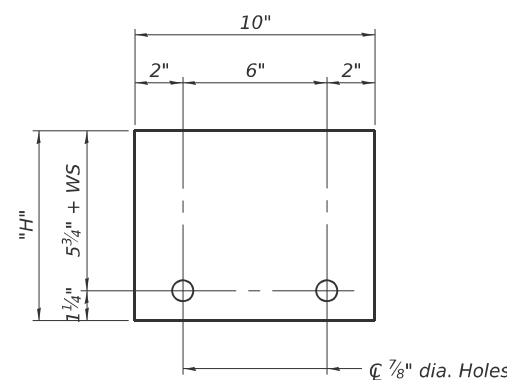

STEEL RETAINER R 1" x "H" x 10"
(Detail III)

Notes:
 Cost of retainer assembly is included with Temporary Concrete Barrier.
 A retainer assembly shall be located at the approximate C of each temporary concrete barrier.
 The retainer plate shall not be removed until the concrete on the adjacent stage is ready to be poured. For Detail III applications the retainer plate shall not be removed until just prior to placing the adjacent beam.
 When the 'A' dimension is less than 1 1/2", the wood block shall be omitted and the barrier shall be placed in direct contact with the steel retainer plate. For deck beam applications the minimum required 'A' distance is 6" to accommodate the shear key clamping device.

Detail I - Installation for a new bridge deck or bridge slab.

Detail II - Installation for a new deck beam with an initial concrete wearing surface. Additional bar splicers shall be provided at 6'-0" centers and paired with the bar splicers of the concrete wearing surface reinforcement to accommodate the installation of the retainer assemblies. The cost of the additional bar splicers is included with the concrete wearing surface.

Detail III - Installation for a new deck beam with no initial wearing surface or with an initial hot-mix asphalt (HMA) wearing surface present. The deck beam directly beneath the temporary concrete barrier shall be fabricated with bar splicer inserts in the side of the beam, as detailed, to accommodate the installation of the retainer assemblies. A pair of bar splicers, 6" apart, shall be placed at 6'-0" centers along the length of the beam. The cost of the bar splicers is included with the deck beam.

RAILING CRITERIA

NCHRP 350 Test Level	3
Railing Weight (plf)	440

R-27 5-15-2023

MODEL: Sheet
 FILE NAME: Y:\DOT\1445-01_74D08\74D08 DESIGN\CADD\SP SN 058-0068-0069\Common sheets\0580068-D774D08-05-TCB.dgn



USER NAME = nhc
 ESCA PROJECT NO. = 1445.01
 PLOT SCALE = 0.2" / in.
 PLOT DATE = 1/20/2026

DESIGNED - ELH 07/25
 CHECKED - RDP 07/25
 DRAWN - NHC 07/25
 CHECKED - ELH 07/25

REVISED -
 REVISED -
 REVISED -
 REVISED -

STATE OF ILLINOIS
 DEPARTMENT OF TRANSPORTATION

TEMPORARY CONCRETE BARRIER
 SN 058-0068 (WB) & SN 058-0069 (EB)

SHEET 5 OF 33 SHEETS

F.A.I. RTE.	SECTION	COUNTY	TOTAL SHEETS	SHEET NO.
72	D7 BRIDGE REPAIRS 2026-3	MACON	108	44
CONTRACT NO. 74D08				
ILLINOIS FED. AID PROJECT				

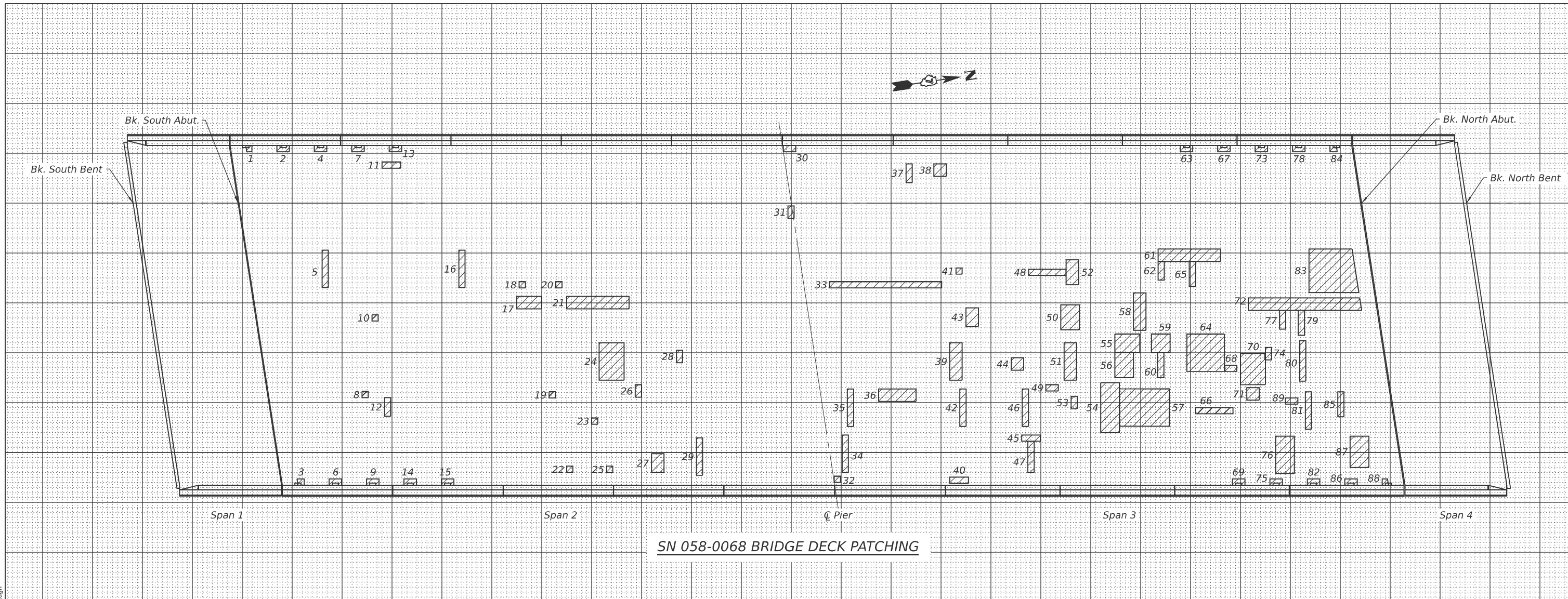

SN 058-0068 BRIDGE DECK PATCHING

PATCH NO.	SIZE (FEET)		DECK SLAB REPAIR (FD, TY I) SQ YD	DECK SLAB REPAIR (FD, TY II) SQ YD
	LENGTH	WIDTH		
1	1	1	0.1	
2	2	1	0.2	
3	1	1	0.1	
4	2	1	0.2	
5	1	6		0.7
6	2	1	0.2	
7	2	1	0.2	
8	1	1	0.1	
9	2	1	0.2	
10	1	1	0.1	
11	3	1	0.3	
12	1	3	0.3	
13	2	1	0.2	
14	2	1	0.2	
15	2	1	0.2	
16	1	6		0.7
17	4	2		0.9
18	1	1	0.1	
19	1	1	0.1	
20	1	1	0.1	
21	10	2		2.2
22	1	1	0.1	
23	1	1	0.1	

PATCH NO.	SIZE (FEET)		DECK SLAB REPAIR (FD, TY I) SQ YD	DECK SLAB REPAIR (FD, TY II) SQ YD
	LENGTH	WIDTH		
24	4	6		2.7
25	1	1	0.1	
26	1	2	0.2	
27	2	3		0.7
28	1	2	0.2	
29	1	6		0.7
30	2	1	0.2	
31	1	2	0.2	
32	1	1	0.1	
33	18	1		2.0
34	1	6		0.7
35	1	6		0.7
36	6	2		1.3
37	1	3	0.3	
38	2	2	0.4	
39	2	6		1.3
40	3	1	0.3	
41	1	1	0.1	
42	1	6		0.7
43	2	3		0.7
44	2	2	0.4	
45	3	1		0.3
46	1	6		0.7

PATCH NO.	SIZE (FEET)		DECK SLAB REPAIR (FD, TY I) SQ YD	DECK SLAB REPAIR (FD, TY II) SQ YD
	LENGTH	WIDTH		
47	1	5		0.6
48	6	1		0.7
49	2	1	0.2	
50	3	4		1.3
51	2	6		1.3
52	2	4		0.9
53	1	2	0.2	
54	3	8		2.7
55	4	3		1.3
56	3	4		1.3
57	8	6		5.3
58	2	6		1.3
59	3	3		1.0
60	1	4		0.4
61	10	2		2.2
62	1	3		0.3
63	2	1	0.2	
64	6	6		4.0
65	1	4		0.4
66	6	1		0.7
67	2	1	0.2	
68	2	1		0.2
69	2	1	0.2	

PATCH NO.	SIZE (FEET)		DECK SLAB REPAIR (FD, TY I) SQ YD	DECK SLAB REPAIR (FD, TY II) SQ YD
	LENGTH	WIDTH		
70	4	5		2.2
71	2	2	0.4	
72	18	2		4.0
73	2	1	0.2	
74	1	2		0.2
75	2	1	0.2	
76	3	6		2.0
77	1	3		0.3
78	2	1	0.2	
79	1	4		0.4
80	1	6.5		0.7
81	1	6		0.7
82	2	1	0.2	
83	8	7		6.2
84	1	1	0.1	
85	1	4	0.4	
86	2	1	0.2	
87	3	5		1.7
88	1	1	0.1	
89	2	1	0.2	
TOTAL ROUNDS TO:			10.0	65.0

THE LOCATIONS AND SIZES SHOWN GRAPHICALLY ABOVE ARE APPROXIMATE. SEE THIS TABLE FOR ACTUAL SIZES.



DATE OF SURVEY: 06-03-25
 SURVEY BY: ESCA CONSULTANTS
 METHOD OF SURVEY: VISUAL

**ESTIMATED
 PAY QUANTITIES:**

DECK SLAB REPAIR
 (FULL DEPTH, TYPE I)
 10.0 SQ YD

DECK SLAB REPAIR
 (FULL DEPTH, TYPE II)
 65.0 SQ YD

**STATE OF ILLINOIS
 DEPARTMENT OF TRANSPORTATION**

**BRIDGE DECK PATCHING
 SN 058-0068 (WB)**

(Sheet 1 of 2)

MODEL: Sheet
 FILE NAME: Y:\DOT\1445-01_74D08\74D08 DESIGN\CAD\SP SN 058-0068-0069\Common sheets\058-0068-0069-06-DeckPatching\WB.dgn



USER NAME = nhc
 ESCA PROJECT NO. = 1445.01
 PLOT SCALE = 0.2" = 1' / in.
 PLOT DATE = 1/20/2026

DESIGNED - ELH 07/25
 CHECKED - RDP 07/25
 DRAWN - NHC 07/25
 CHECKED - ELH 07/25

REVISED -
 REVISED -
 REVISED -
 REVISED -

SHEET 6 OF 33 SHEETS

F.A.I. RTE.	SECTION	COUNTY	TOTAL SHEETS	SHEET NO.
72	D7 BRIDGE REPAIRS 2026-3	MACON	108	45
CONTRACT NO. 74D08				
ILLINOIS FED. AID PROJECT				

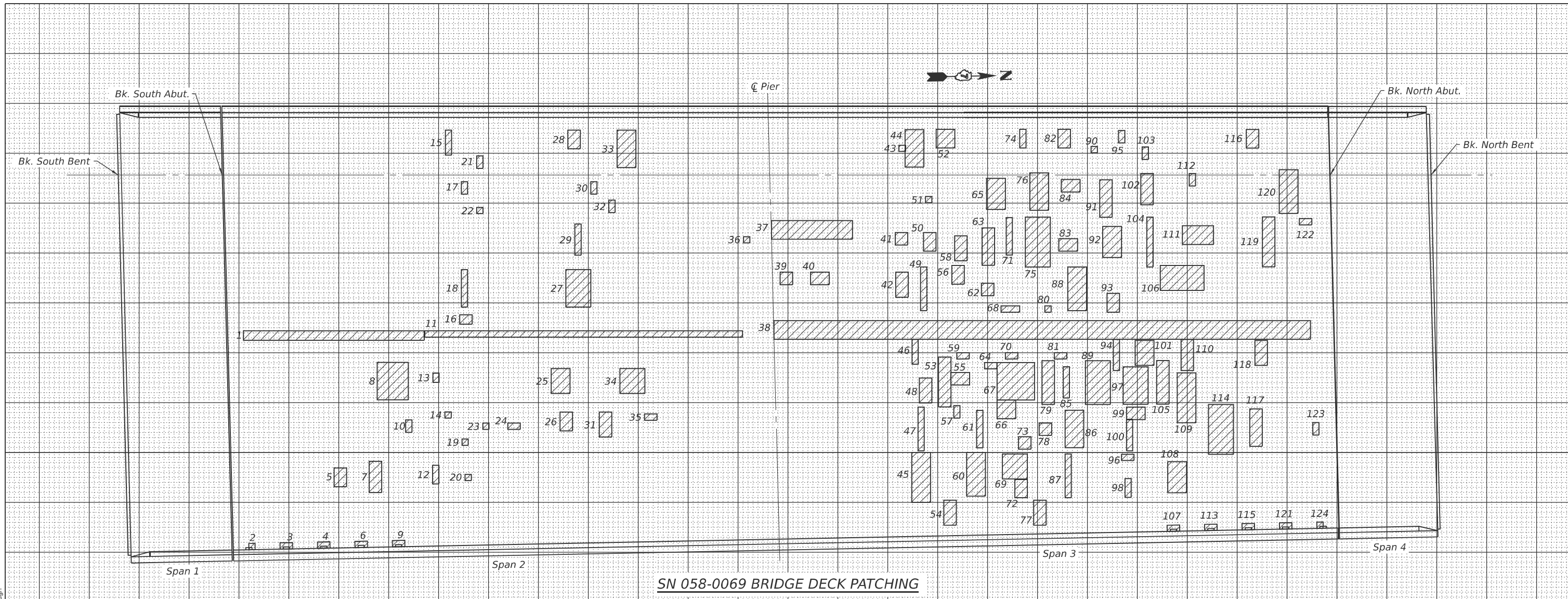

SN 058-0069 BRIDGE DECK PATCHING

PATCH NO.	LENGTH (FEET)	WIDTH (FEET)	DECK SLAB REPAIR (FD, TY I) SQ YD	DECK SLAB REPAIR (FD, TY II) SQ YD
1	29	1.5		4.8
2	1	1	0.1	
3	2	1	0.2	
4	2	1	0.2	
5	2	3		0.7
6	2	1	0.2	
7	2	5		1.1
8	5	6		3.3
9	2	1	0.2	
10	1	2	0.2	
11	51	1		5.7
12	1	3	0.3	
13	1	2	0.2	
14	1	1	0.1	
15	1	4	0.4	
16	2	1.5	0.3	
17	1	2	0.2	
18	1	6		0.7
19	1	1	0.1	
20	1	1	0.1	
21	1	2	0.2	
22	1	1	0.1	
23	1	1	0.1	
24	2	1	0.2	
25	3	4		1.3

PATCH NO.	LENGTH (FEET)	WIDTH (FEET)	DECK SLAB REPAIR (FD, TY I) SQ YD	DECK SLAB REPAIR (FD, TY II) SQ YD
26	2	3		0.7
27	4	6		2.7
28	2	3		0.7
29	1	5		0.6
30	1	2	0.2	
31	2	4		0.9
32	1	2	0.2	
33	3	6		2.0
34	4	4		1.8
35	2	1	0.2	
36	1	1	0.1	
37	13	3		4.3
38	86	3		28.7
39	2	2	0.4	
40	3	2		0.7
41	2	2	0.4	
42	2	4		0.9
43	1	1	0.1	
44	3	6		2.0
45	3	8		2.7
46	1	4		0.4
47	1	7		0.8
48	2	4		0.9
49	1	7		0.8
50	2	3		0.7

PATCH NO.	LENGTH (FEET)	WIDTH (FEET)	DECK SLAB REPAIR (FD, TY I) SQ YD	DECK SLAB REPAIR (FD, TY II) SQ YD
51	1	1	0.1	
52	3	3		1.0
53	2	8		1.8
54	2	4		0.9
55	3	2		0.7
56	2	3		0.7
57	1	2	0.2	
58	2	4		0.9
59	2	1	0.2	
60	4	7		3.1
61	1	6		0.7
62	2	2	0.4	
63	2	6		1.3
64	2	1		0.2
65	3	5		1.7
66	3	3		1.0
67	6	6		4.0
68	3	1	0.3	
69	4	4		1.8
70	2	1	0.2	
71	1	6		0.7
72	2	3		0.7
73	2	2	0.4	
74	1	3	0.3	
75	4	8		3.6

PATCH NO.	LENGTH (FEET)	WIDTH (FEET)	DECK SLAB REPAIR (FD, TY I) SQ YD	DECK SLAB REPAIR (FD, TY II) SQ YD
76	3	6		2.0
77	2	4		0.9
78	2	2	0.4	
79	2	7		1.6
80	1	1	0.1	
81	2	1	0.2	
82	2	3		0.7
83	3	2		0.7
84	3	2		0.7
85	1	5		0.6
86	3	6		2.0
87	1	7		0.8
88	3	7		2.3
89	4	7		3.1
90	1	1	0.1	
91	2	6		1.3
92	3	5		1.7
93	2	3		0.7
94	1	5		0.6
95	1	2	0.2	
96	2	1	0.2	
97	4	6		2.7
98	1	3	0.3	
99	3	2		0.7
100	1	5		0.6

PATCH NO.	LENGTH (FEET)	WIDTH (FEET)	DECK SLAB REPAIR (FD, TY I) SQ YD	DECK SLAB REPAIR (FD, TY II) SQ YD
101	3	4		1.3
102	2	5		1.1
103	1	2	0.2	
104	1	8		0.9
105	2	7		1.6
106	7	4		3.1
107	2	1	0.2	
108	3	5		1.7
109	3	8		2.7
110	2	5		1.1
111	5	3		1.7
112	1	2	0.2	
113	2	1	0.2	
114	4	8		3.6
115	2	1	0.2	
116	2	3		0.7
117	2	6		1.3
118	2	4		0.9
119	2	8		1.8
120	3	7		2.3
121	2	1	0.2	
122	2	1	0.2	
123	1	2	0.2	
124	1	1	0.1	
TOTAL ROUNDS TO:			11.0	145.0

THE LOCATIONS AND SIZES SHOWN GRAPHICALLY ABOVE ARE APPROXIMATE. SEE THIS TABLE FOR ACTUAL SIZES.



DATE OF SURVEY: 06-03-25
 SURVEY BY: ESCA CONSULTANTS
 METHOD OF SURVEY: VISUAL

ESTIMATED PAY QUANTITIES:
 DECK SLAB REPAIR (FULL DEPTH, TYPE I) 11.0 SQ YD
 DECK SLAB REPAIR (FULL DEPTH, TYPE II) 145.0 SQ YD

(Sheet 2 of 2)

STATE OF ILLINOIS DEPARTMENT OF TRANSPORTATION

BRIDGE DECK PATCHING SN 058-0069 (EB)

SHEET 7 OF 33 SHEETS

F.A.I. RTE.	SECTION	COUNTY	TOTAL SHEETS	SHEET NO.
72	D7 BRIDGE REPAIRS 2026-3	MACON	108	46

CONTRACT NO. 74D08

ILLINOIS FED. AID PROJECT

MODEL: Sheet
 FILE NAME: Y:\DOT\1445-01_74D08\74D08 DESIGN\CADD\SP SN 058-0068-0069\Common sheets\0580068-0069-07-DeckPatchingEB.dgn



USER NAME = nhc
 ESCA PROJECT NO. = 1445.01
 PLOT SCALE = 0.2" = 1' / in.
 PLOT DATE = 1/20/2026

DESIGNED - ELH	07/25	REVISED -
CHECKED - RDP	07/25	REVISED -
DRAWN - NHC	07/25	REVISED -
CHECKED - ELH	07/25	REVISED -

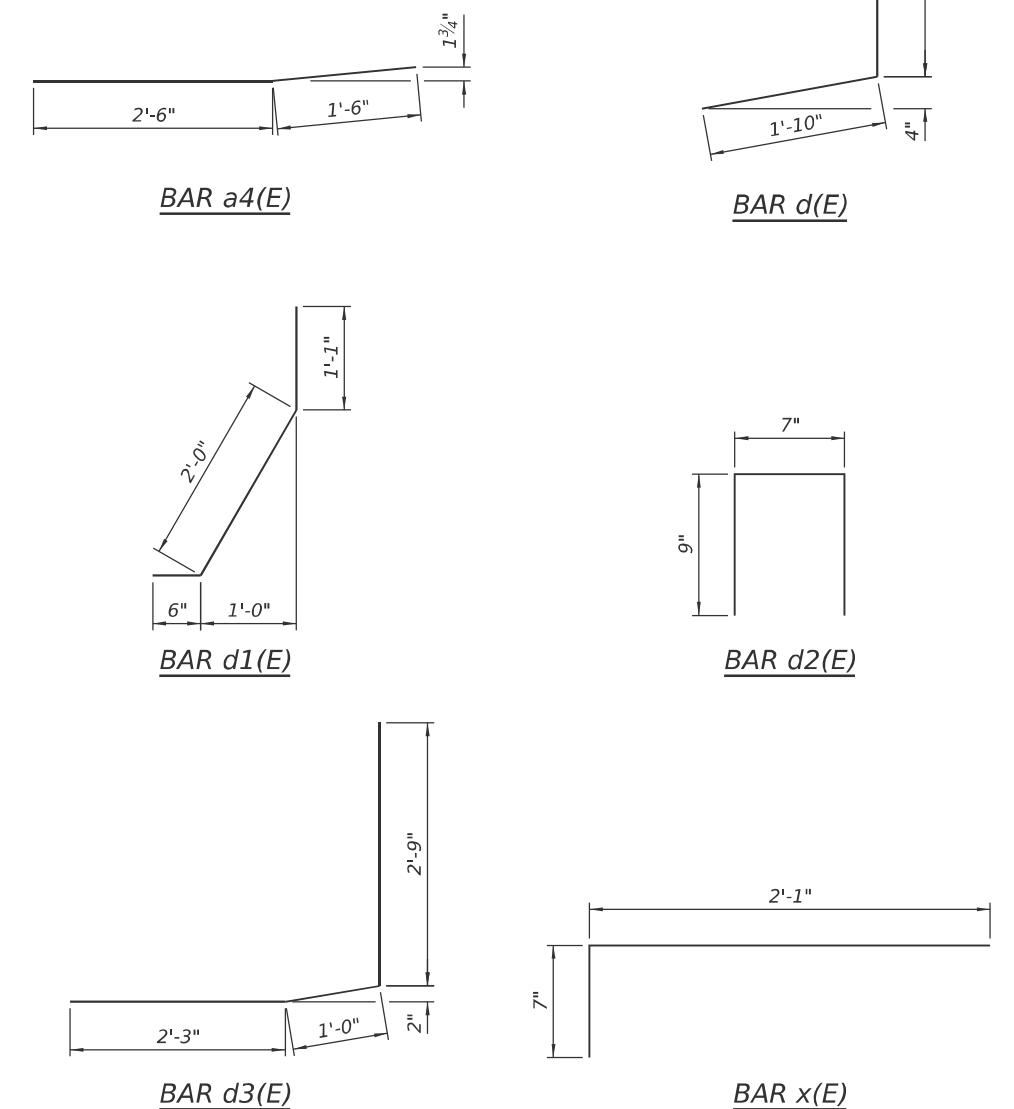
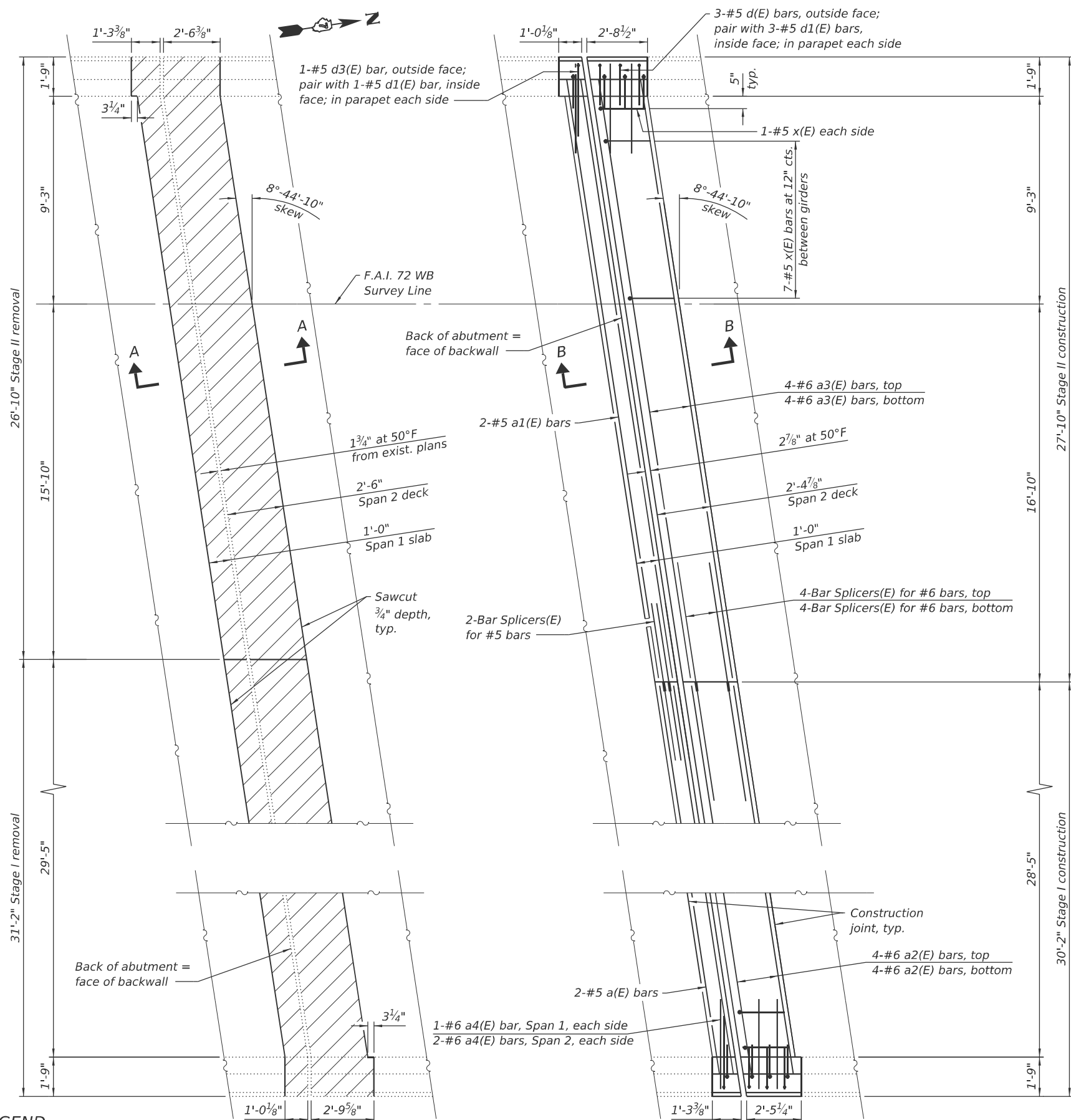

SN 058-0068 BILL OF MATERIAL
(For Two Abutments)

Bar	Number		Total	Size	Length	Shape	
	Stage I	Stage II					
a(E)	4	0	4	#5	29'-4"	—	
a1(E)	0	4	4	#5	27'-0"	—	
a2(E)	16	0	16	#6	29'-4"	—	
a3(E)	0	16	16	#6	27'-0"	—	
a4(E)	6	6	12	#6	4'-0"	—	
d(E)	6	6	12	#5	4'-7"	J	
d1(E)	8	8	16	#5	3'-7"	J	
d2(E)	4	4	8	#4	2'-1"	J	
d3(E)	2	2	4	#5	6'-0"	J	
x(E)	52	50	102	#5	2'-8"	—	
Reinforcement Bars, Epoxy Coated						Pound	2,100
Concrete Removal						Cu. Yd.	15.9
Concrete Superstructure						Cu. Yd.	15.7
Bar Splicers						Each	20

Notes:
For Section A-A and Section B-B see Sheet 11 of 33.
Trim ends of existing longitudinal reinforcement in decks and parapets to provide minimum clearance for the expansion joint. Cost is included in Concrete Removal.

LEGEND
Concrete Removal

SN 058-0068 EXISTING PARTIAL PLAN
(South Abutment shown, North Abutment similar)

SN 058-0068 PROPOSED PARTIAL PLAN
(South Abutment shown, North Abutment similar)

(Sheet 1 of 5)

MODEL: Sheet
FILE NAME: Y:\DOT\1445-01_74D08\74D08 DESIGN\CADD\SP 058-0068-0069\Common sheets\0580068-D774D08-08-Expansion\01Dils.dgn



USER NAME = nhc
ESCA PROJECT NO. = 1445.01
PLOT SCALE = 0:2" = 1' / in.
PLOT DATE = 1/20/2026

DESIGNED - ELH 07/25
CHECKED - RDP 07/25
DRAWN - NHC 07/25
CHECKED - ELH 07/25

REVISED -
REVISED -
REVISED -
REVISED -

**STATE OF ILLINOIS
DEPARTMENT OF TRANSPORTATION**

**EXPANSION JOINT REPLACEMENT DETAILS
SN 058-0068 (WB)**

SHEET 8 OF 33 SHEETS

F.A.I. RTE.	SECTION	COUNTY	TOTAL SHEETS	SHEET NO.
72	D7 BRIDGE REPAIRS 2026-3	MACON	108	47
CONTRACT NO. 74D08				
ILLINOIS FED. AID PROJECT				

MODEL: Sheet
 FILE NAME: Y:\DOT\1445-01_74D08\74D08 DESIGN\CADD\SP SN 058-0068-0069\Common sheets\0580068-D774D08-09-Expansion\01Dils.dgn

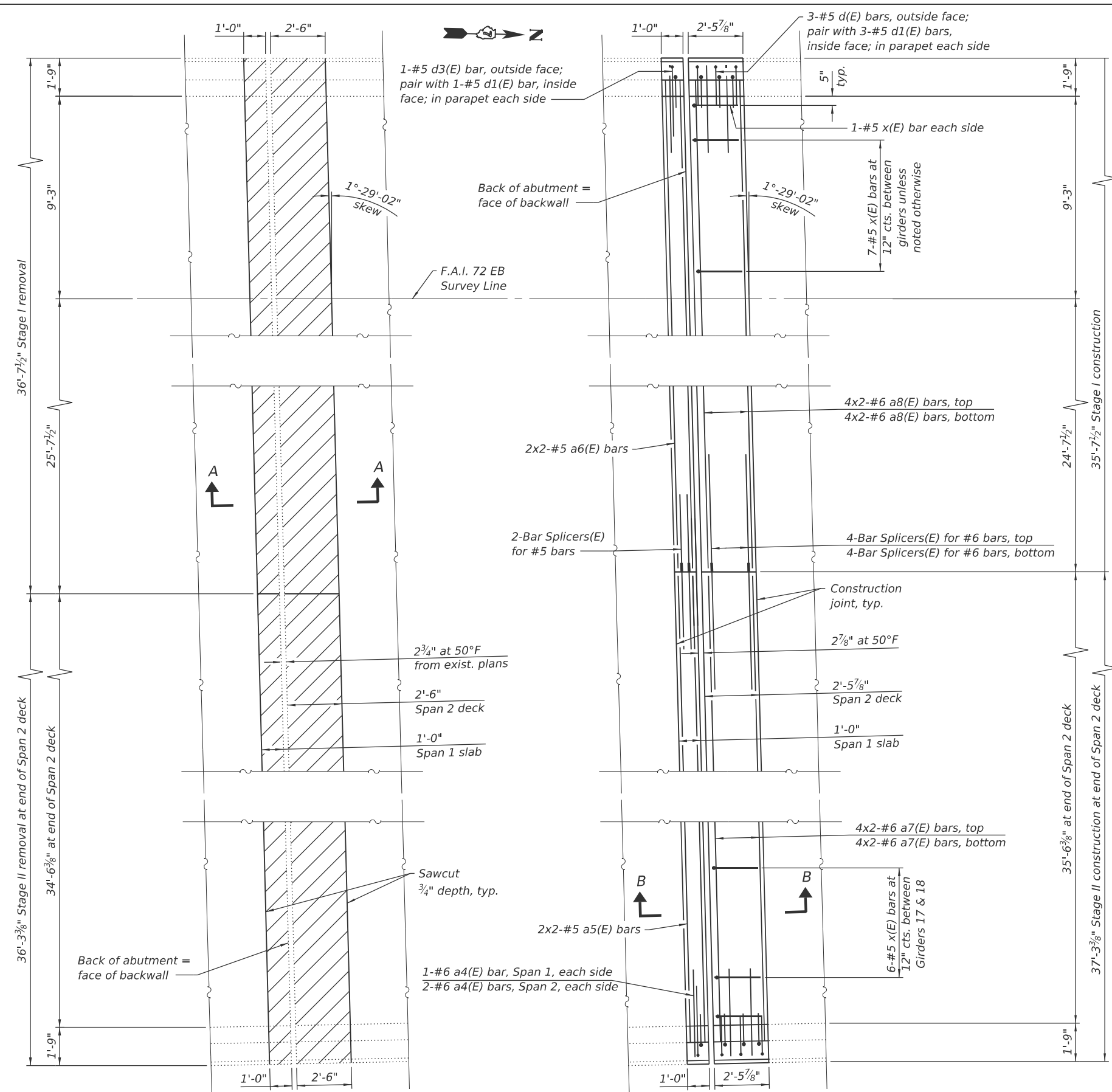

MINIMUM BAR LAP

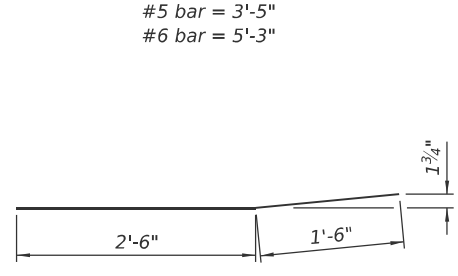

BAR a4(E)

BAR d(E)

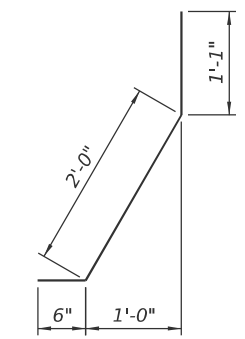

BAR d1(E)

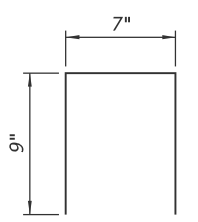

BAR d2(E)

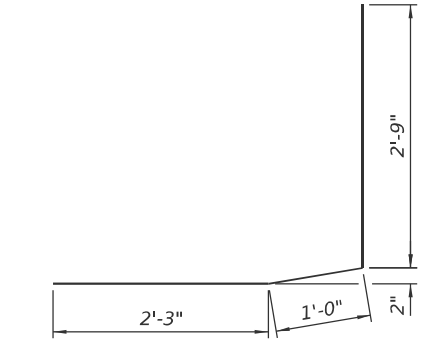

BAR d3(E)

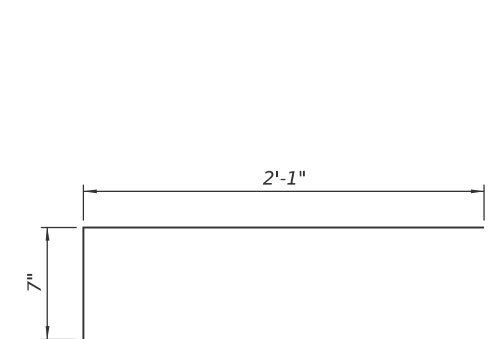

BAR x(E)

SN 058-0069 BILL OF MATERIAL
 (South Abutment)

Bar	Number		Total	Size	Length	Shape
	Stage I	Stage II				
a4(E)	3	3	6	#6	4'-0"	—
a5(E)	0	4	4	#5	20'-4"	—
a6(E)	4	0	4	#5	19'-6"	—
a7(E)	0	16	16	#6	21'-3"	—
a8(E)	16	0	16	#6	20'-5"	—
d(E)	3	3	6	#5	4'-7"	J
d1(E)	4	4	8	#5	3'-7"	J
d2(E)	2	2	4	#4	2'-1"	J
d3(E)	1	1	2	#5	6'-0"	J
x(E)	30	34	64	#5	2'-8"	—
Reinforcement Bars, Epoxy Coated					Pound	1,460
Concrete Removal					Cu. Yd.	9.5
Concrete Superstructure					Cu. Yd.	9.6
Bar Splicers					Each	10

Notes:
 For Section A-A and Section B-B see Sheet 11 of 33.
 Trim ends of existing longitudinal reinforcement in decks and parapets to provide minimum clearance for the expansion joint. Cost is included in Concrete Removal.
 Bars indicated thus 4x2-#6 etc. indicates 4 lines of bars with 2 lengths per line.

LEGEND

Concrete Removal

SN 058-0069 SOUTH ABUTMENT EXISTING PARTIAL PLAN

SN 058-0069 SOUTH ABUTMENT PROPOSED PARTIAL PLAN

(Sheet 2 of 5)



USER NAME = nhc
 ESCA PROJECT NO. = 1445.01
 PLOT SCALE = 0.2" = 1' / in.
 PLOT DATE = 1/20/2026

DESIGNED - ELH 07/25
 CHECKED - RDP 07/25
 DRAWN - NHC 07/25
 CHECKED - ELH 07/25

REVISED -
 REVISED -
 REVISED -
 REVISED -

STATE OF ILLINOIS DEPARTMENT OF TRANSPORTATION

EXPANSION JOINT REPLACEMENT DETAILS SN 058-0069 (EB)

SHEET 9 OF 33 SHEETS

F.A.I. RTE.	SECTION	COUNTY	TOTAL SHEETS	SHEET NO.
72	D7 BRIDGE REPAIRS 2026-3	MACON	108	48
CONTRACT NO. 74D08				
ILLINOIS FED. AID PROJECT				

MODEL: Sheet
 FILE NAME: Y:\DOT\1445-01_74D08\74D08 DESIGN\CADD\SP SN 058-0068-0069\Common sheets\0580068-D774D08-10-Expansion\01Dils.dgn

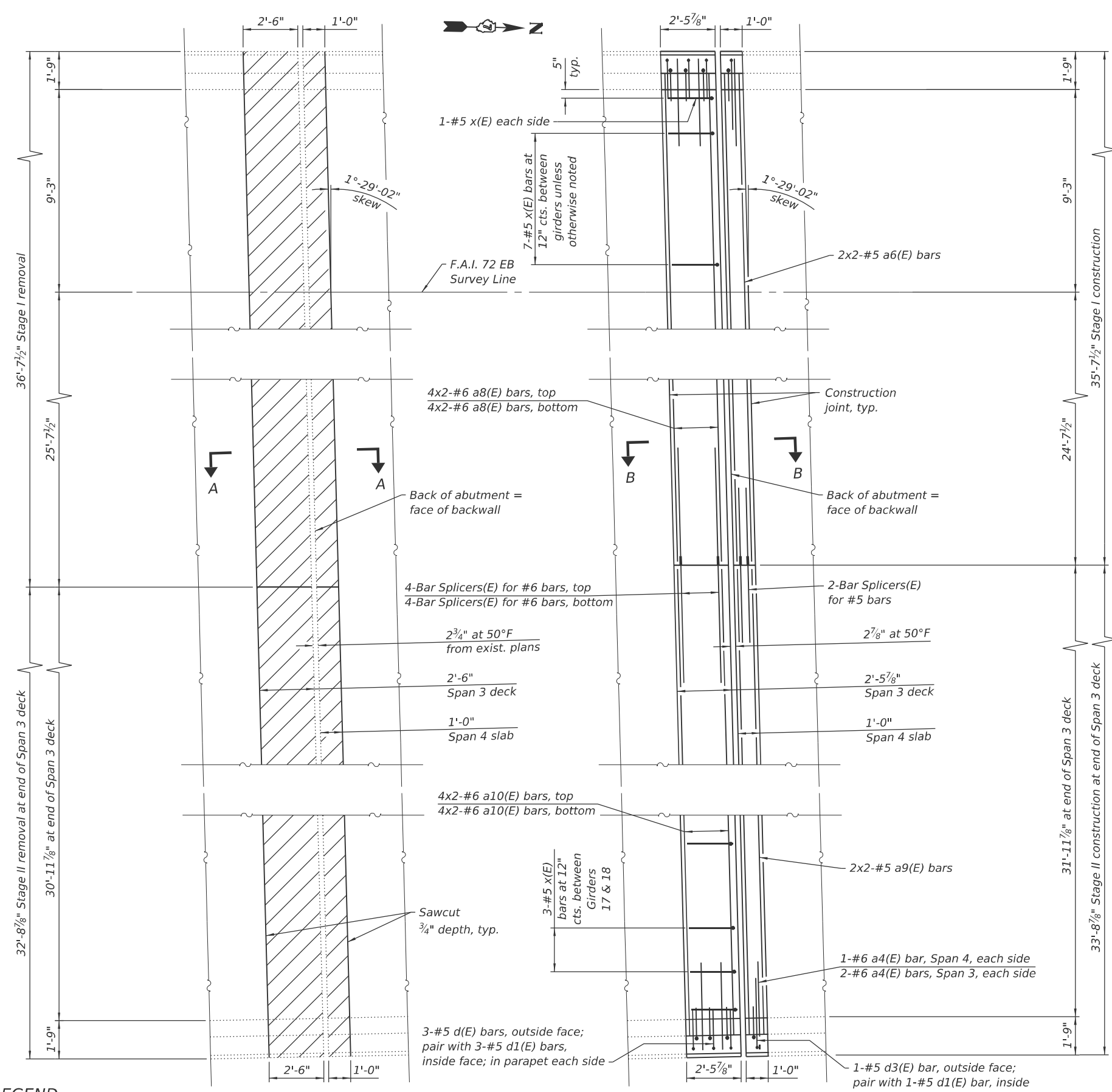

MINIMUM BAR LAP

#5 bar = 3'-5"
 #6 bar = 5'-3"

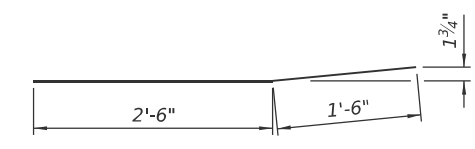

BAR a4(E)

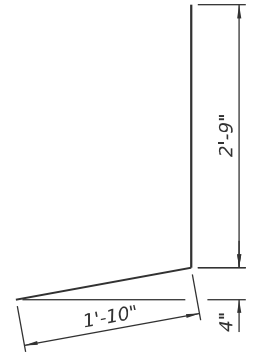

BAR d(E)

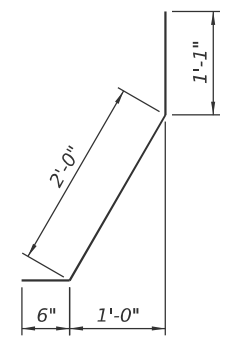

BAR d1(E)

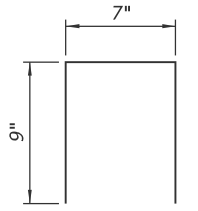

BAR d2(E)

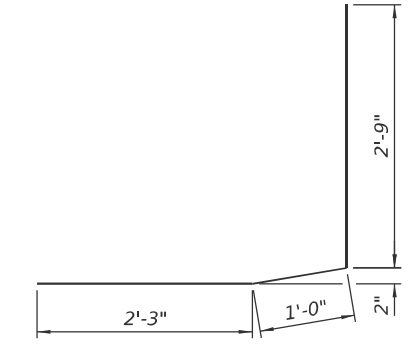

BAR d3(E)

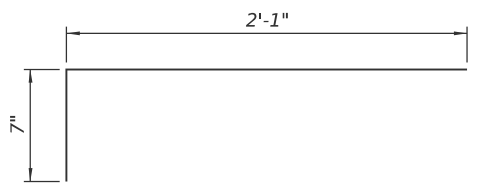

BAR x(E)

SN 058-0069 BILL OF MATERIAL
 (North Abutment)

Bar	Number		Total	Size	Length	Shape	
	Stage I	Stage II					
a4(E)	3	3	6	#6	4'-0"	—	
a6(E)	4	0	4	#5	19'-6"	—	
a8(E)	16	0	16	#6	20'-5"	—	
a9(E)	0	4	4	#5	18'-7"	—	
a10(E)	0	16	16	#6	19'-6"	—	
d(E)	3	3	6	#5	4'-7"	J	
d1(E)	4	4	8	#5	3'-7"	J	
d2(E)	2	2	4	#4	2'-1"	□	
d3(E)	1	1	2	#5	6'-0"	J	
x(E)	30	31	61	#5	2'-8"	—	
Reinforcement Bars, Epoxy Coated						Pound	1,410
Concrete Removal						Cu. Yd.	9.0
Concrete Superstructure						Cu. Yd.	9.2
Bar Splicers						Each	10

Notes:
 For Section A-A and Section B-B see Sheet 11 of 33.
 Trim ends of existing longitudinal reinforcement in decks and parapets to provide minimum clearance for the expansion joint. Cost is included in Concrete Removal.
 Bars indicated thus 4x2-#6 etc. indicates 4 lines of bars with 2 lengths per line.

LEGEND
 Concrete Removal

SN 058-0069 NORTH ABUTMENT
 EXISTING PARTIAL PLAN

SN 058-0069 NORTH ABUTMENT
 PROPOSED PARTIAL PLAN

(Sheet 3 of 5)



USER NAME = nhc	DESIGNED - ELH 07/25	REVISED -
ESCA PROJECT NO. = 1445.01	CHECKED - RDP 07/25	REVISED -
PLOT SCALE = 0:2" = 1' / in.	DRAWN - NHC 07/25	REVISED -
PLOT DATE = 1/20/2026	CHECKED - ELH 07/25	REVISED -

STATE OF ILLINOIS
DEPARTMENT OF TRANSPORTATION

EXPANSION JOINT REPLACEMENT DETAILS
SN 058-0069 (EB)

SHEET 10 OF 33 SHEETS

F.A.I. RTE.	SECTION	COUNTY	TOTAL SHEETS	SHEET NO.
72	D7 BRIDGE REPAIRS 2026-3	MACON	108	49
CONTRACT NO. 74D08				
ILLINOIS FED. AID PROJECT				

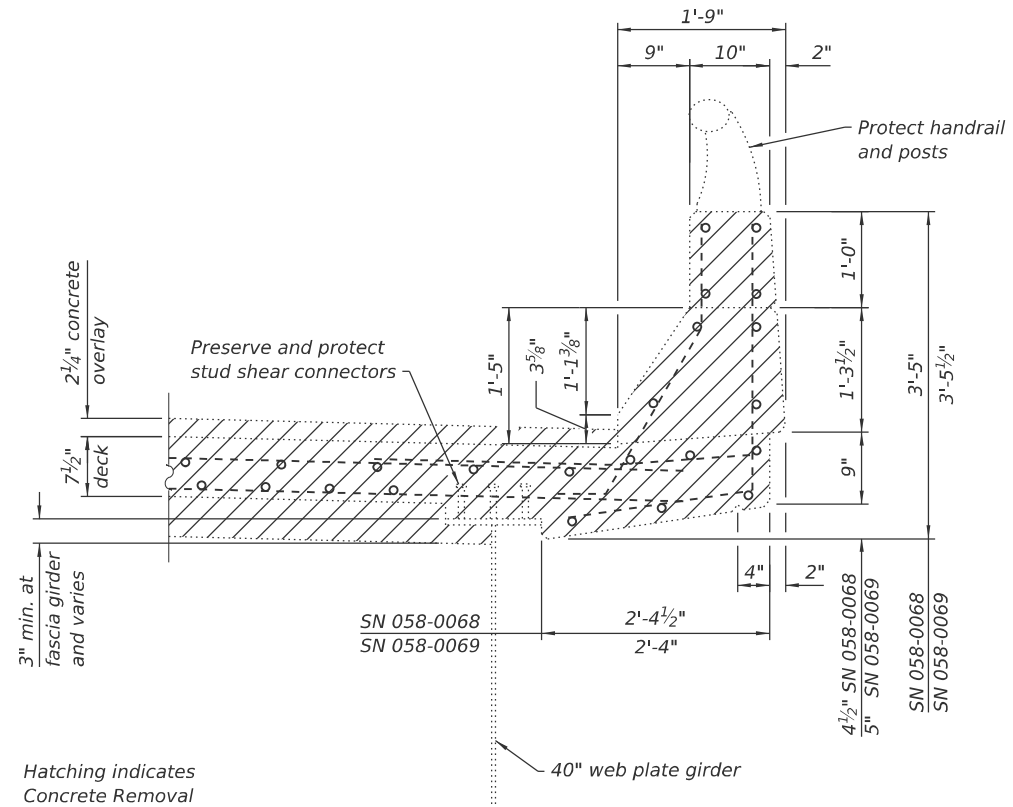

SECTION THRU EXISTING PARAPET AT MAIN SPANS
(Horizontal dimensions at right angles)

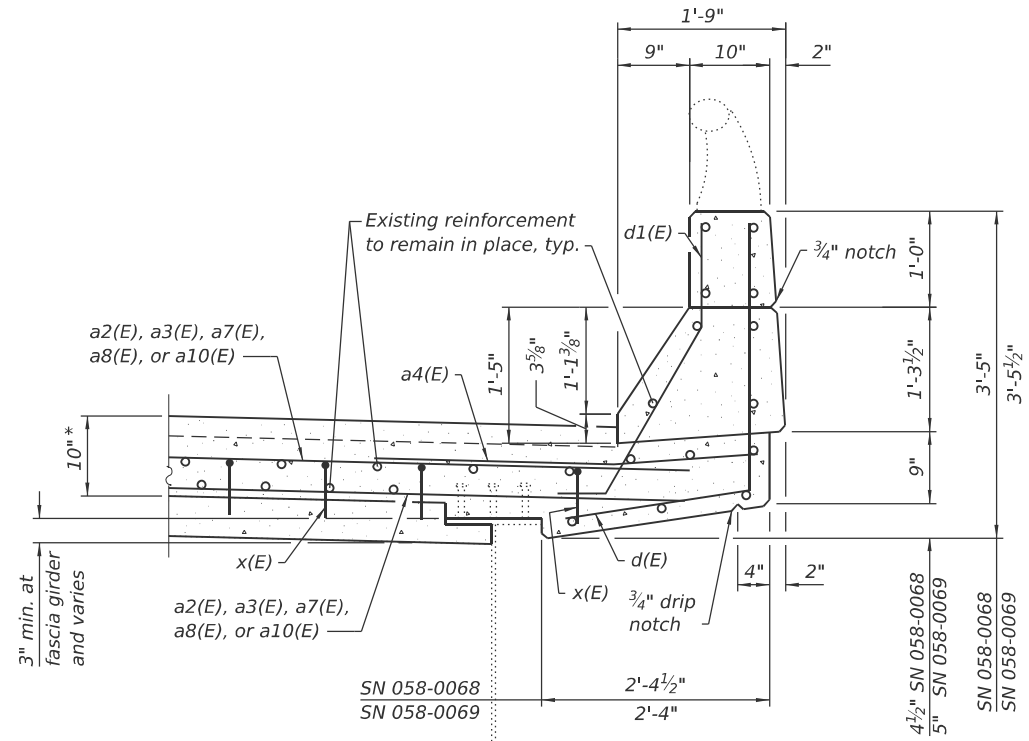

SECTION THRU PROPOSED PARAPET AT MAIN SPANS
(Horizontal dimensions at right angles)

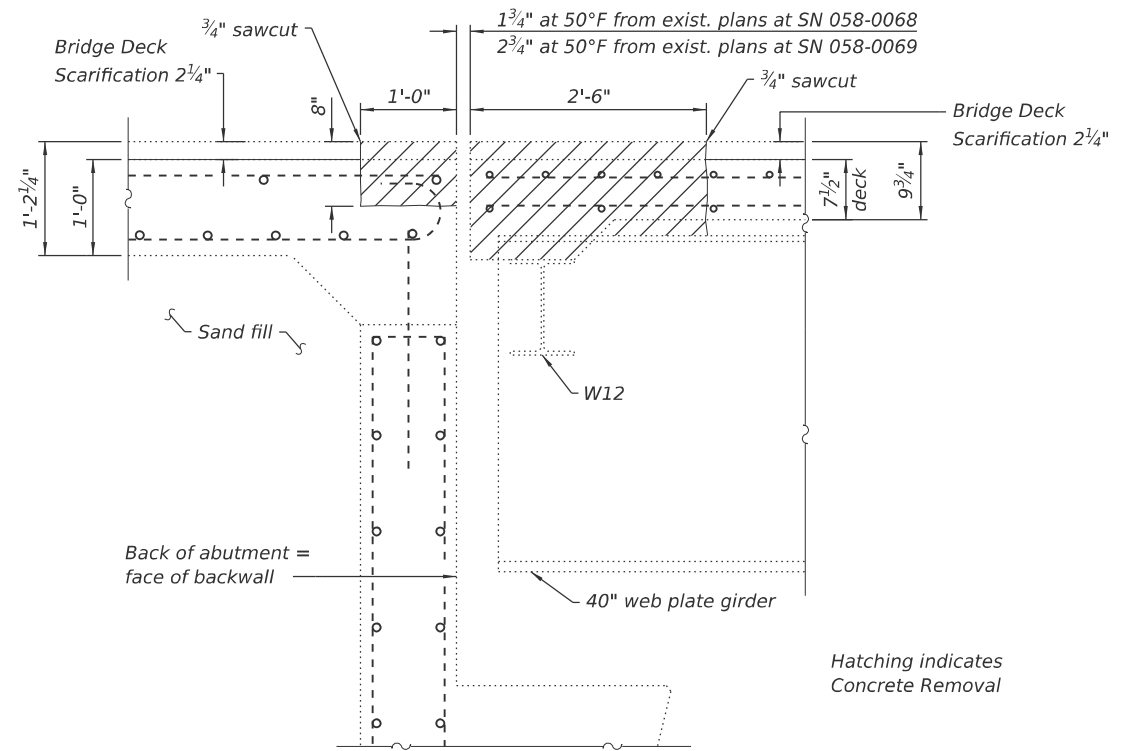

SECTION A-A
(Horizontal dimensions at right angles)

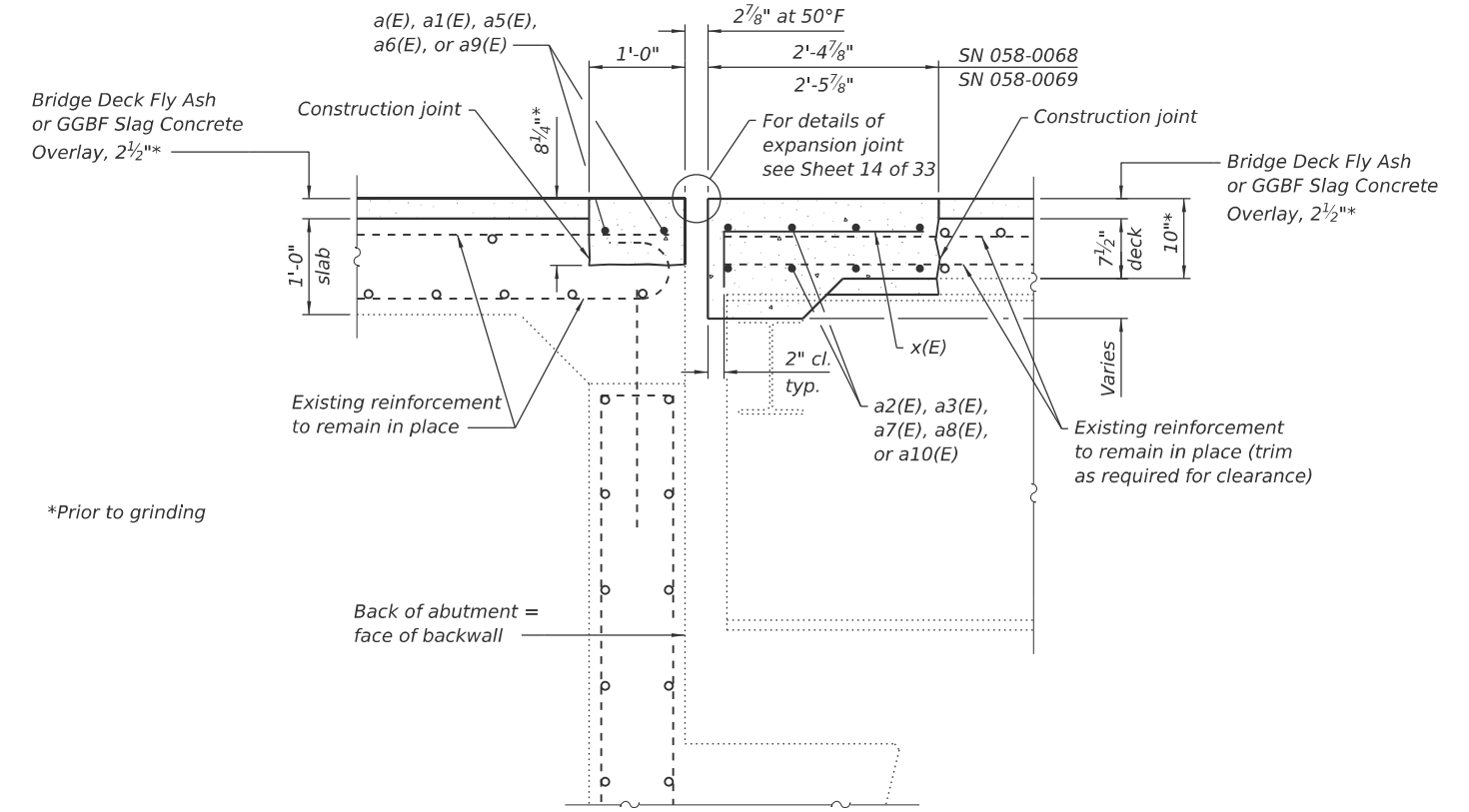

SECTION B-B
(Horizontal dimensions at right angles)

(Sheet 4 of 5)

MODEL: Sheet
FILE NAME: Y:\DOT\1445-01_74D08\74D08 DESIGN\CADD\SP 058-0068-0069\Common sheets\0580068-D774D08-1-Expansion\1Dils.dgn



USER NAME = nhc	DESIGNED - ELH 07/25	REVISED -
ESCA PROJECT NO. = 1445.01	CHECKED - RDP 07/25	REVISED -
PLOT SCALE = 0.2" = 1' / in.	DRAWN - NHC 07/25	REVISED -
PLOT DATE = 1/20/2026	CHECKED - ELH 07/25	REVISED -

STATE OF ILLINOIS
DEPARTMENT OF TRANSPORTATION

EXPANSION JOINT REPLACEMENT DETAILS
SN 058-0068 (WB) & SN 058-0069 (EB)

SHEET 11 OF 33 SHEETS

F.A.I. RTE.	SECTION	COUNTY	TOTAL SHEETS	SHEET NO.
72	D7 BRIDGE REPAIRS 2026-3	MACON	108	50
CONTRACT NO. 74D08				
ILLINOIS FED. AID PROJECT				

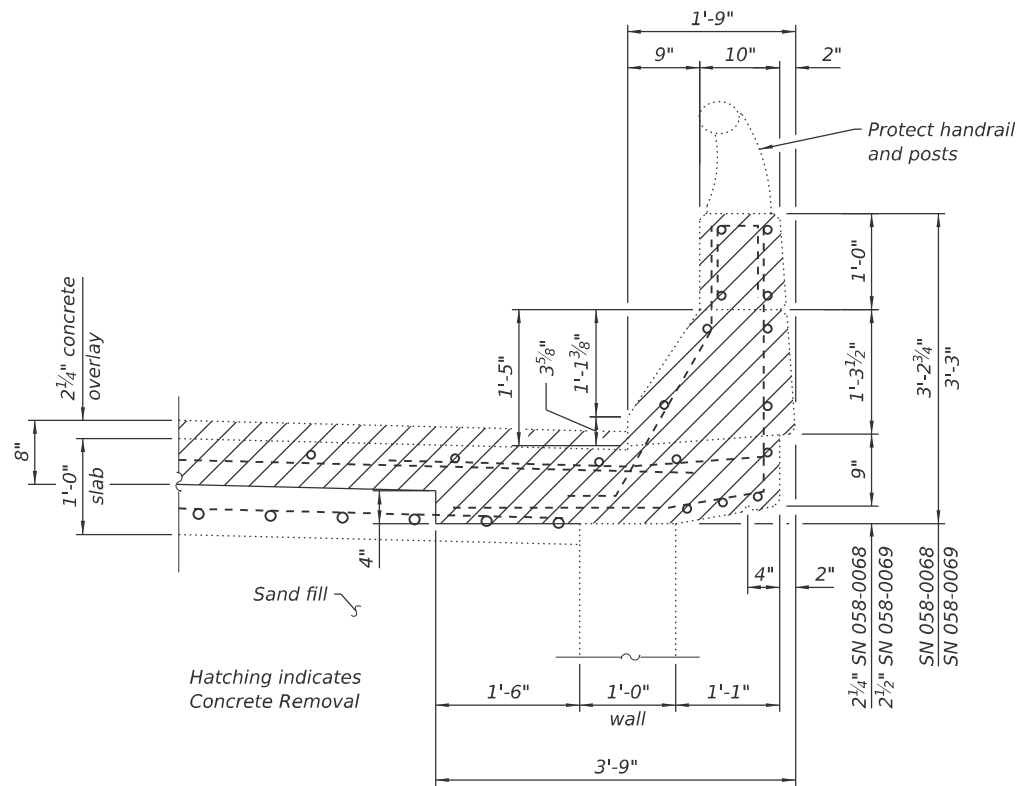

SECTION THRU EXISTING PARAPET AT END SPANS
(Horizontal dimensions at right angles)

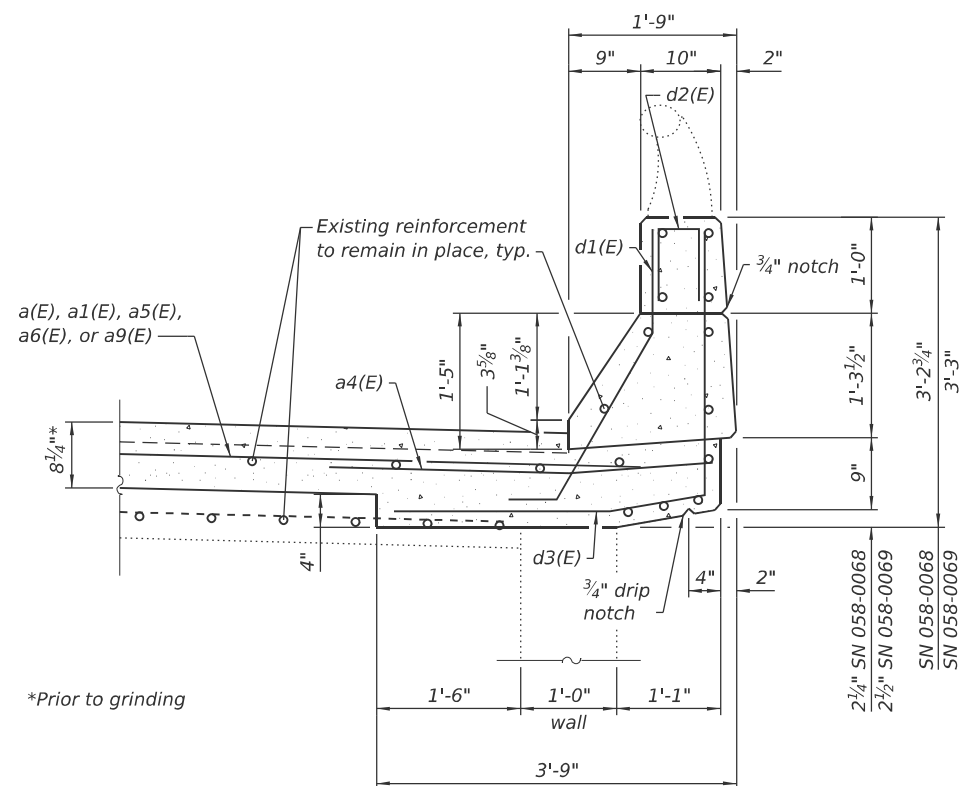

SECTION THRU PROPOSED PARAPET AT END SPANS
(Horizontal dimensions at right angles)

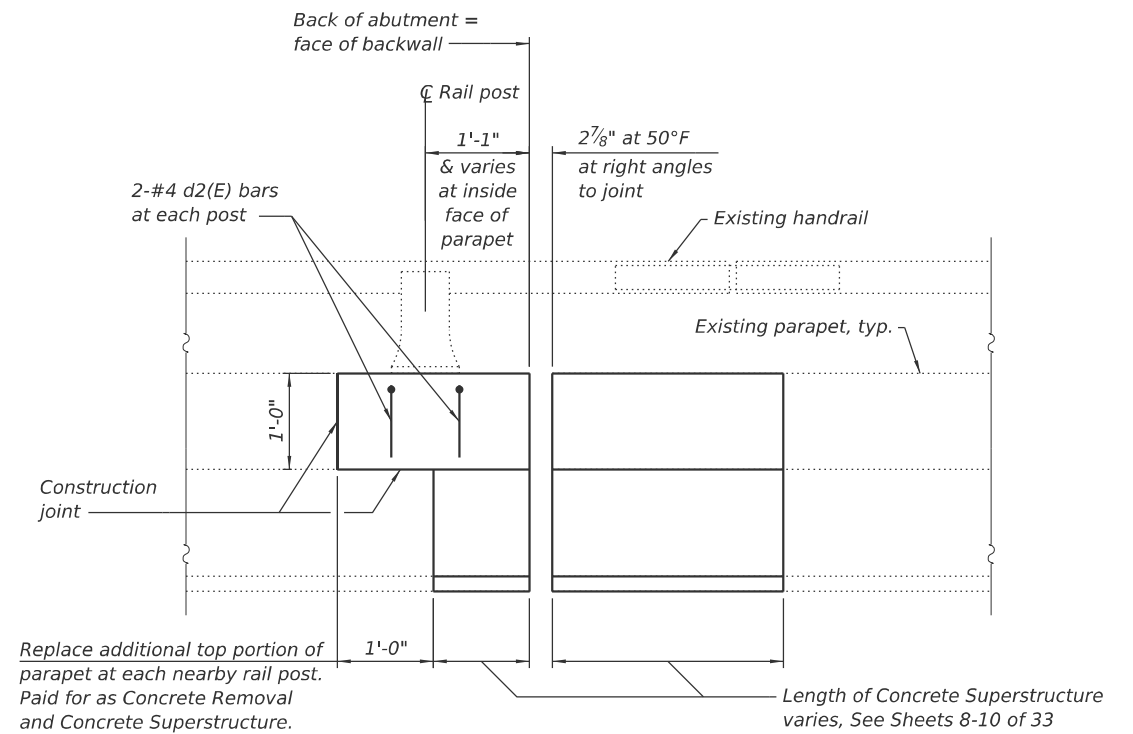

INSIDE ELEVATION AT EXPANSION JOINT RAIL POST
(Four locations at SN 058-0068; four locations at SN 058-0069)

(Sheet 5 of 5)

MODEL: Sheet
FILE NAME: Y:\DOT11445-01_74D08\74D08 DESIGN\CADD\SP SN 058-0068-0069\Common sheets\0580068-D774D08-12-Expansion\ID1s.dgn



USER NAME = nhc
ESCA PROJECT NO. = 1445.01
PLOT SCALE = 0.2" = 1' / in.
PLOT DATE = 1/20/2026

DESIGNED - ELH 07/25
CHECKED - RDP 07/25
DRAWN - NHC 07/25
CHECKED - ELH 07/25

REVISED -
REVISED -
REVISED -
REVISED -

STATE OF ILLINOIS
DEPARTMENT OF TRANSPORTATION

EXPANSION JOINT REPLACEMENT DETAILS
SN 058-0068 (WB) & SN 058-0069 (EB)

SHEET 12 OF 33 SHEETS

F.A.I. RTE.	SECTION	COUNTY	TOTAL SHEETS	SHEET NO.
72	D7 BRIDGE REPAIRS 2026-3	MACON	108	51
CONTRACT NO. 74D08				
ILLINOIS FED. AID PROJECT				

Notes:

Fiberglass pipe shall conform to ASTM D2996, with short-time rupture strength hoop tensile stress of 30,000 p.s.i. minimum.

The exterior surfaces of the floor drains shall be painted according to Article 506 with the finish coat as specified. The exterior surfaces of the drains shall be cleaned according to the Society of Protective Coating's Spec. SSPC-SP1 prior to painting.

The top portion of aluminum floor drains shall be coated with 5 mils of either bitumen paint or epoxy paint to minimize reaction with wet concrete.

The clamping device shall be galvanized according to AASHTO M 232. Cost of clamping device included with Floor Drains.

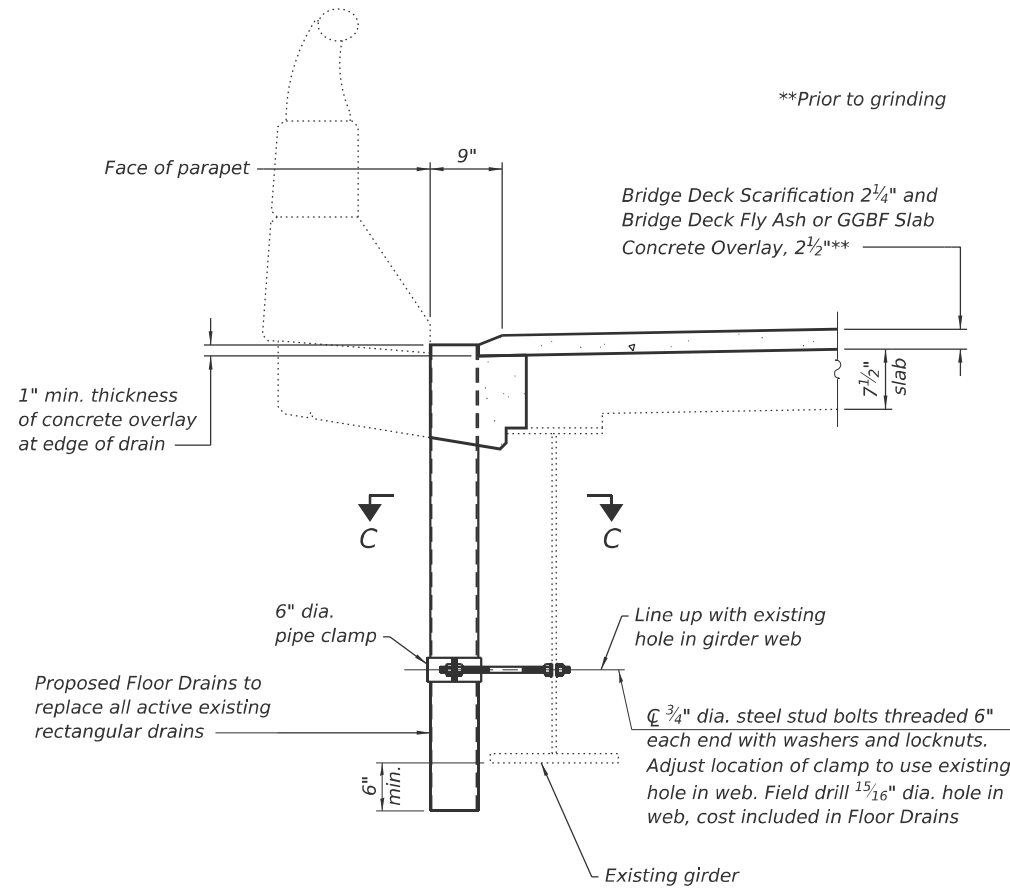

SECTION THRU PROPOSED FLOOR DRAIN

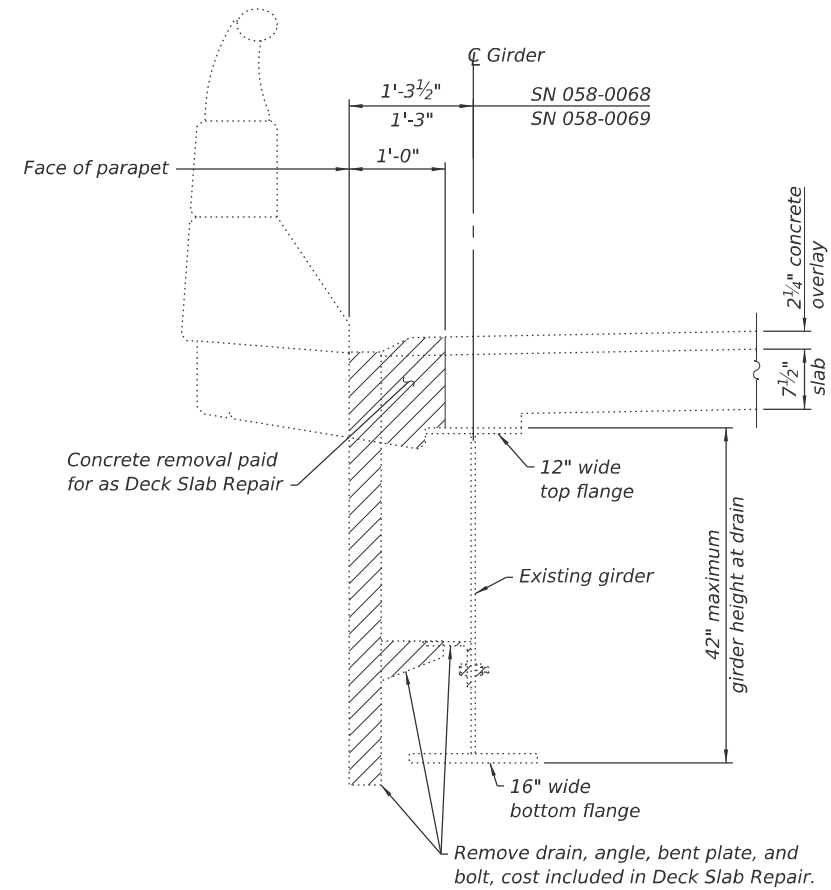

SECTION THRU EXISTING DECK DRAIN

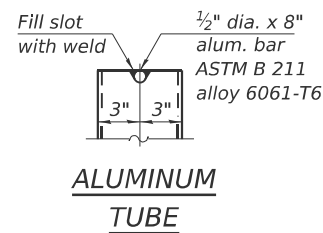

ALUMINUM TUBE

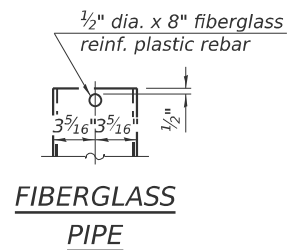

FIBERGLASS PIPE

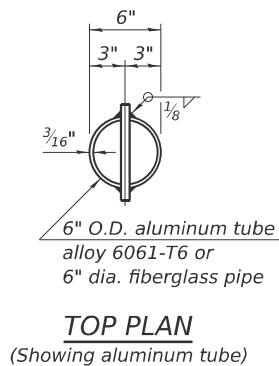

TOP PLAN (Showing aluminum tube)

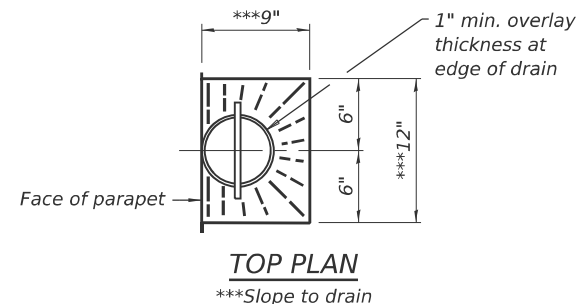

TOP PLAN *Slope to drain**

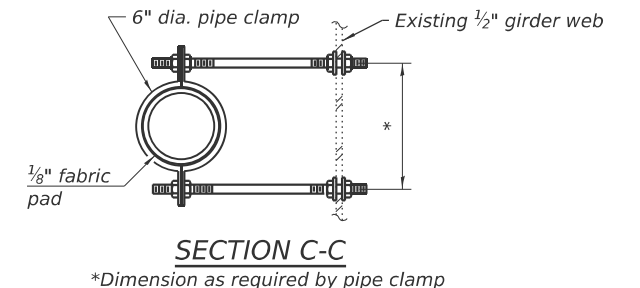

SECTION C-C *Dimension as required by pipe clamp

MODEL: Sheet
FILE NAME: Y:\DOT\1445-01_74D08\74D08 DESIGN\CADD\SP SN 058-0068-0069\Common sheets\0580068-D774D08-13-DeckDrainDtls.dgn



USER NAME = nhc
ESCA PROJECT NO. = 1445.01
PLOT SCALE = 0.2" = 1" / in.
PLOT DATE = 1/20/2026

DESIGNED - ELH 07/25
CHECKED - RDP 07/25
DRAWN - NHC 07/25
CHECKED - ELH 07/25

REVISED -
REVISED -
REVISED -
REVISED -

**STATE OF ILLINOIS
DEPARTMENT OF TRANSPORTATION**

**DECK DRAIN DETAILS
SN 058-0068 (WB) & SN 058-0069 (EB)**

SHEET 13 OF 33 SHEETS

F.A.I. RTE.	SECTION	COUNTY	TOTAL SHEETS	SHEET NO.
72	D7 BRIDGE REPAIRS 2026-3	MACON	108	52
CONTRACT NO. 74D08				
ILLINOIS FED. AID PROJECT				

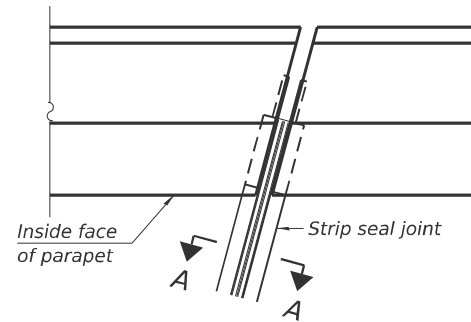

FOR SKEWS $\leq 30^\circ$
PLAN AT PARAPET

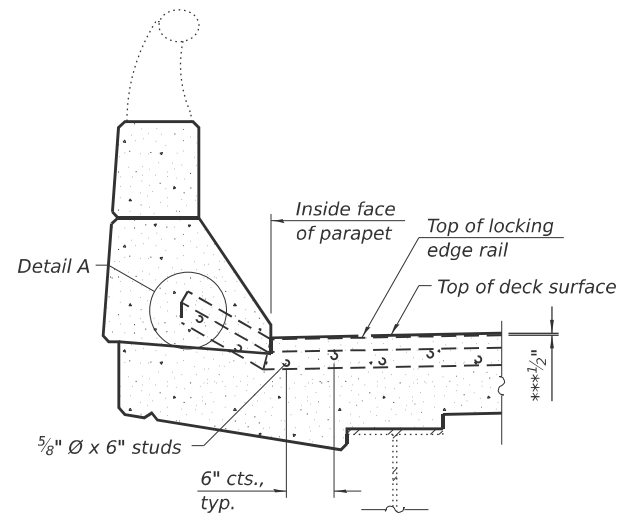

SECTION AT PARAPET

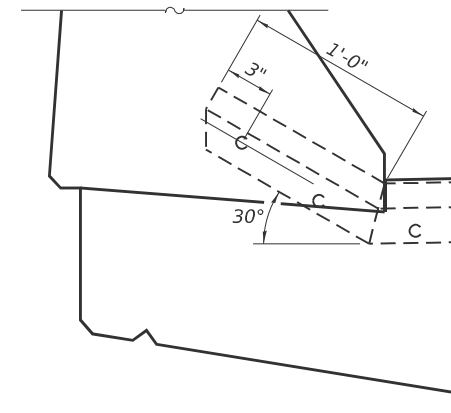

DETAIL A

Notes:
 The strip seal shall be made continuous and shall have a minimum thickness of $\frac{1}{4}$ ". The configuration of the strip seal shall match the configuration of the locking edge rails. Open or "webbed" strip seal gland configurations are not permitted. The gland shall be sized for a maximum rated movement of 4 inches.
 The locking edge rails depicted are configured for typical applications and are conceptual only. The actual configuration of the locking edge rails and matching strip seal may vary from manufacturer to manufacturer provided they fit the application and meet the minimum anchorage shown. Flanged edge rails, however, will not be allowed. Locking edge rails may exceed the $4\frac{1}{2}$ " maximum depth provided the anchorage system is revised according to the manufacturer's recommendation.
 The manufacturer's recommended installation methods shall be followed.
 All steel components shall be galvanized after fabrication according to Article 520.03 of the Standard Specifications.
 The maximum space between locking edge rail segments shall be $\frac{3}{16}$ " and sealed with a suitable sealant; however, any rail joint within 10' measured perpendicular to the face of the curb or parapet shall be welded as shown in the locking edge rail splice detail.
 The concrete opening below the strip seal will vary based on the locking edge rail chosen by the Contractor. Deck and parapet lengths shown elsewhere in the plans are dimensioned to the concrete opening, not the joint opening, and are based on the rolled locking edge rail. If the Contractor elects to use a different locking edge rail, dimensional adjustments may be required.

***Prior to grinding

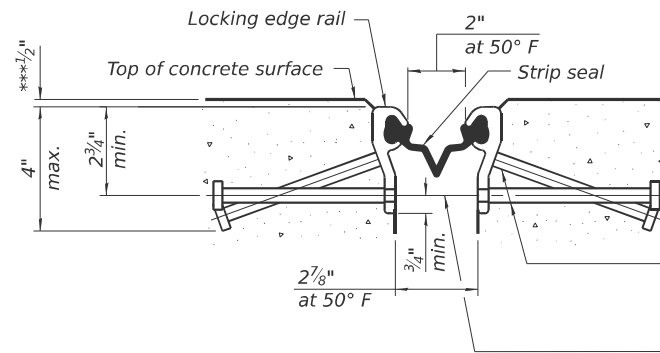

SHOWING ROLLED RAIL JOINT

* $\frac{5}{8}$ " \varnothing x 6" studs @ 6" cts. (alternate angled/bent studs with horizontal studs)

$\frac{3}{8}$ " \varnothing threaded rods in $\frac{7}{16}$ " \varnothing holes at 4'-0" \pm cts. for holding the proper joint opening based on the temperature during the deck pour. Place to miss studs. All rods shall be burned, or sawed off flush with the plates after concrete is set.

SECTION A-A

* Granular or solid flux filled headed studs conforming to Article 1006.32 of the Std. Specs., automatically end welded.

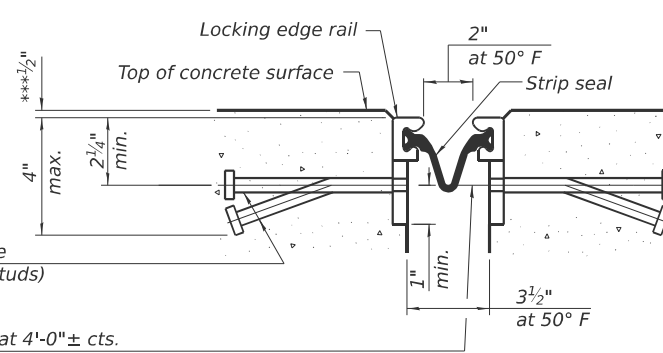

SHOWING WELDED RAIL JOINT

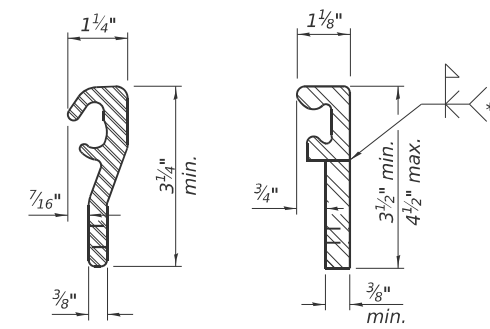

LOCKING EDGE RAILS

** Back gouge not required if complete joint penetration is verified by mock-up.

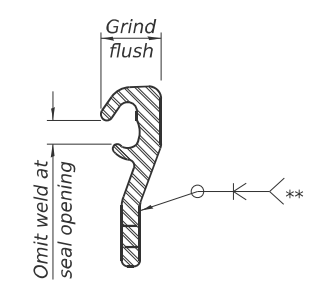

LOCKING EDGE RAIL SPLICE

The inside of the locking edge rail groove shall be free of weld residue. Rolled rail shown, welded rail similar.

SN 058-0068 & SN 058-0069

BILL OF MATERIAL

Item	Unit	Quantity
Preformed Joint Strip Seal	Foot	254

MODEL: Sheet
 FILE NAME: Y:\DOT11445-01_74D08\74D08 DESIGN\CADD\SP SN 058-0068-0069\Common sheets\0580068-D774D08-14-P-15.dgn



USER NAME = nhc
 ESCA PROJECT NO. = 1445.01
 PLOT SCALE = 0.2" = 1' / in.
 PLOT DATE = 1/20/2026

DESIGNED - ELH 07/25
 CHECKED - RDP 07/25
 DRAWN - NHC 07/25
 CHECKED - ELH 07/25

REVISED -
 REVISED -
 REVISED -
 REVISED -

**STATE OF ILLINOIS
 DEPARTMENT OF TRANSPORTATION**

**PREFORMED JOINT STRIP SEAL
 SN 058-0068 (WB) & SN 058-0069 (EB)**

SHEET 14 OF 33 SHEETS

F.A.I. RTE.	SECTION	COUNTY	TOTAL SHEETS	SHEET NO.
72	D7 BRIDGE REPAIRS 2026-3	MACON	108	53
CONTRACT NO. 74D08				
ILLINOIS FED. AID PROJECT				

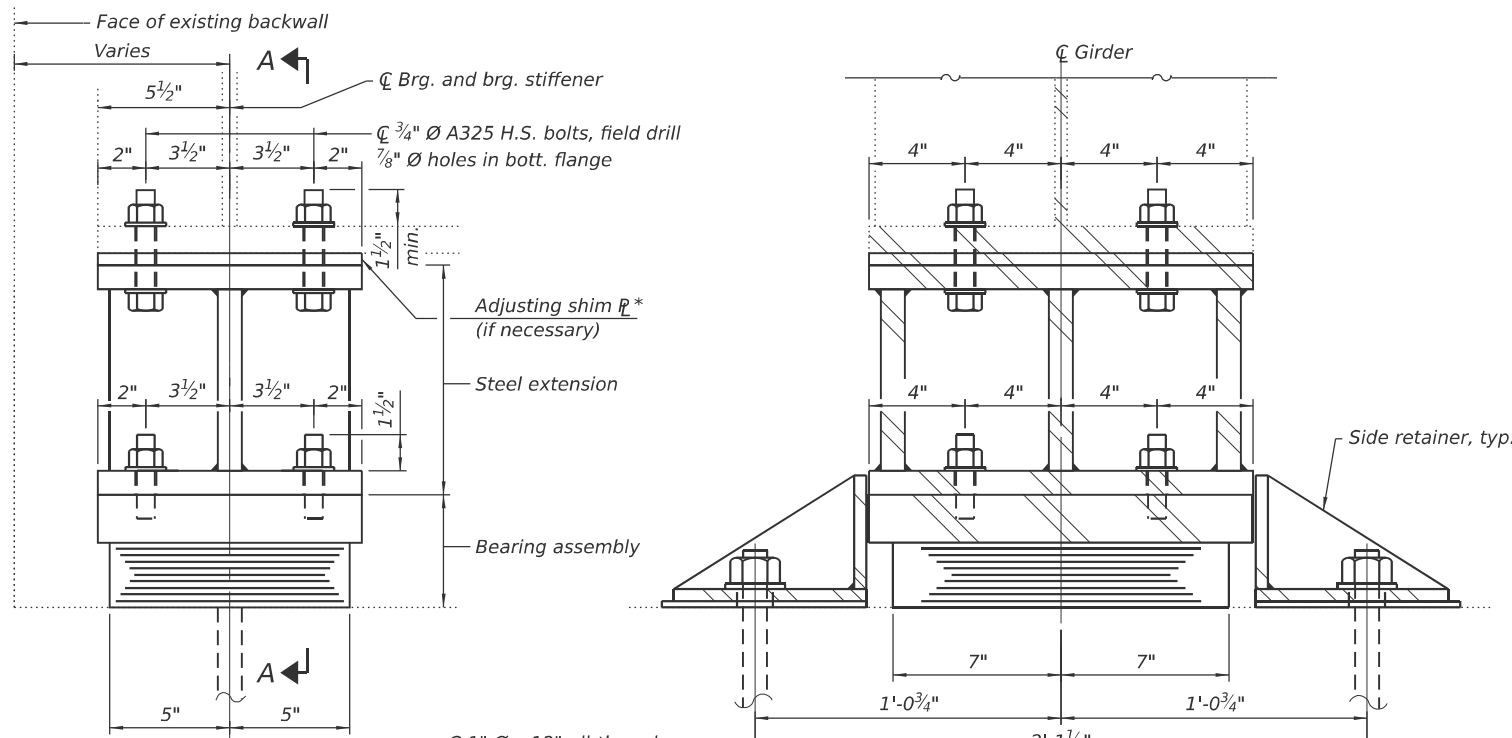

ELEVATION AT ABUT.

*See Shim Plate Tables

1" \varnothing x 12" all-thread anchor bolts (F1554 Grade 55) with 2 1/4" x 2 1/4" x 5/16" \varnothing washer under nut

TYPE I ELASTOMERIC EXP. BRG.

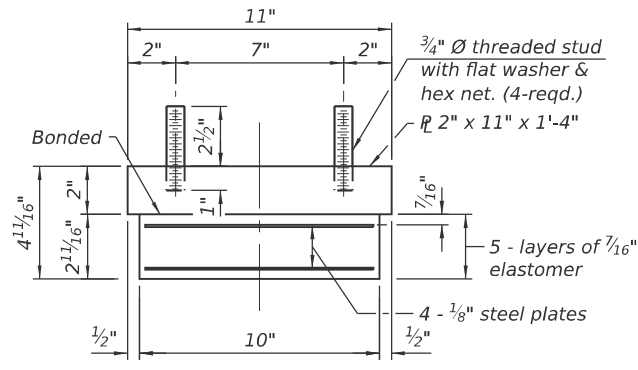

BEARING ASSEMBLY

Note: Shim plates shall not be placed under bearing assembly.

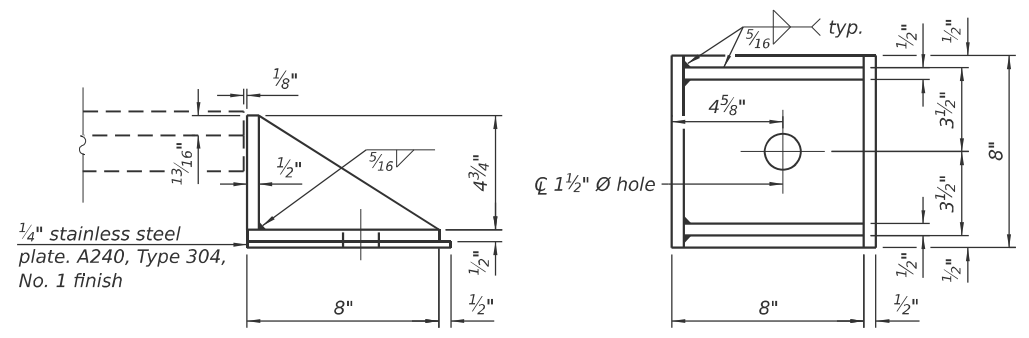

SIDE RETAINER

Equivalent rolled angle with stiffeners will be allowed in lieu of welded plates.

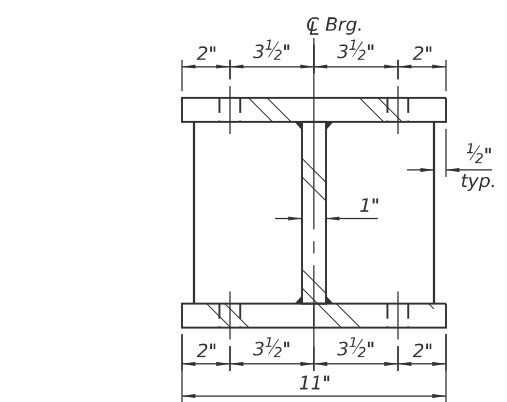

SECTION B-B

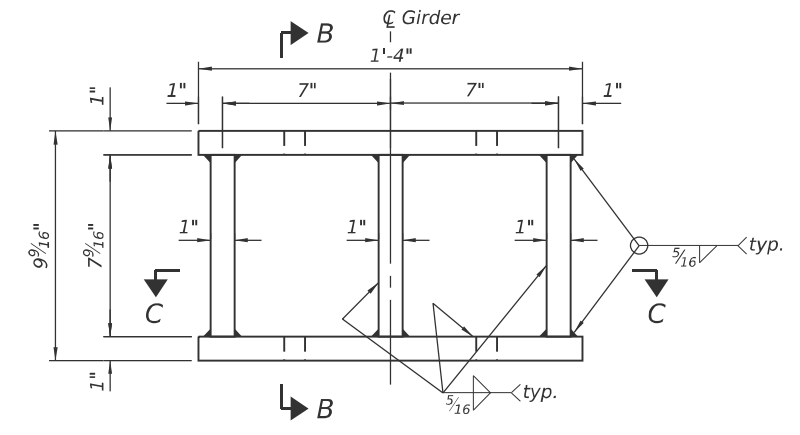

ELEVATION

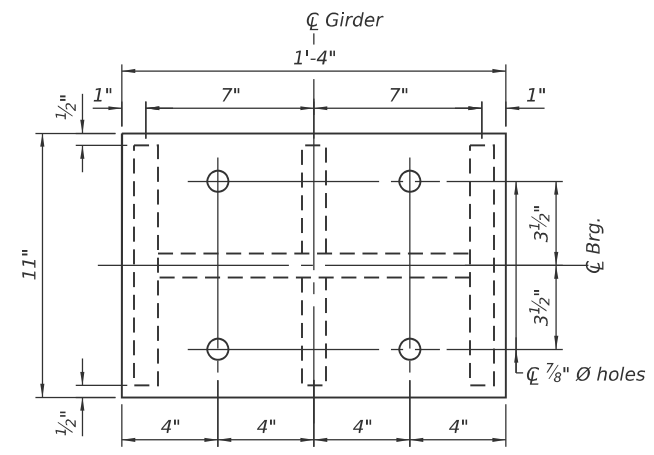

PLAN

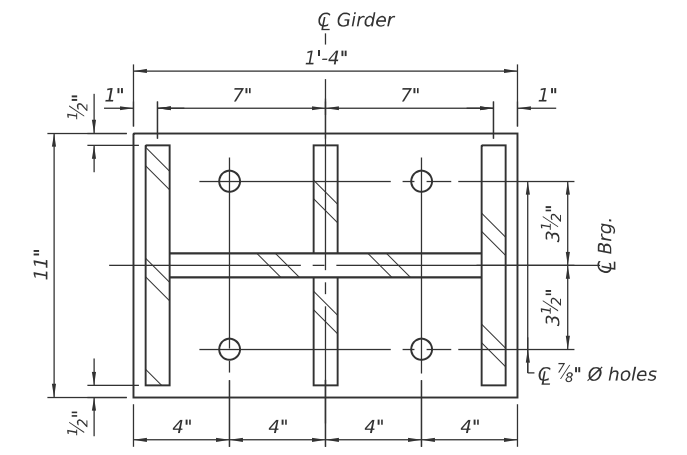

SECTION C-C

FABRICATED STEEL EXTENSION

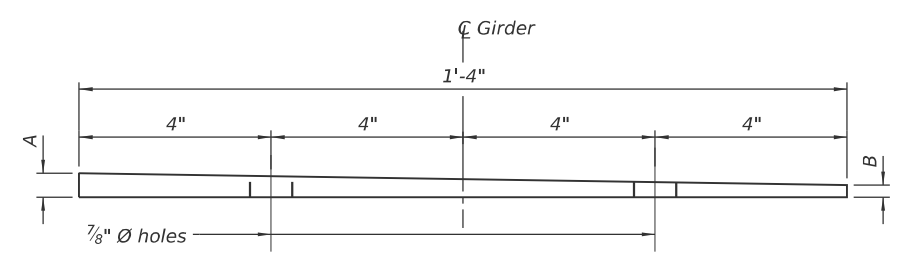

SHIM PLATE

See Shim Plate Tables for dimensions A & B

SN 058-0068 SHIM PLATE TABLE

Beam No.	North Abutment		South Abutment	
	A	B	A	B
1	0	0	0	0
2	0	0	3/8"	3/8"
3	1 1/8"	1 1/8"	0	0
4	7/8"	7/8"	0	0
5	7/8"	1 5/16"	1 1/4"	1 1/16"
6	7/16"	1/4"	1/4"	1/4"
7	1/4"	1/4"	0	0
8	0	0	0	0

SN 058-0069 SHIM PLATE TABLE

Beam No.	North Abutment		South Abutment	
	A	B	A	B
9	1/8"	3/16"	1/4"	1/4"
10	5/8"	1/4"	0	0
11	9/16"	3/8"	1/4"	1/4"
12	1"	1/2"	5/8"	5/8"
13	3/8"	1/8"	1/4"	1/4"
14	0	0	1/4"	1/4"
15	1/8"	3/16"	3/8"	3/8"
16	5/8"	1/4"	1/4"	1/4"
17	1/4"	1/4"	0	0
18	1/2"	1/2"	1/4"	1/4"

SN 058-0068 BEAM REACTION TABLE

	Existing Service Loads
R _{DL} (k)	44.5
R _L (k)	42.4
R _{IM} (k)	9.9
R _{TOTAL} (k)	96.8

SN 058-0069 BEAM REACTION TABLE

	Existing Service Loads
R _{DL} (k)	44.5
R _L (k)	42.4
R _{IM} (k)	9.9
R _{TOTAL} (k)	96.8

(Sheet 1 of 2)

MODEL: Sheet
FILE NAME: Y:\IDOT\1445-01_74D08\74D08 DESIGN\CADD\SP SN 058-0068-0069\Common sheets\0580068-D774D08-15-BearingDtls.dgn



USER NAME = nhc
ESCA PROJECT NO. = 1445.01
PLOT SCALE = 0:2" = 1/4"
PLOT DATE = 1/20/2026

DESIGNED - ELH 01/26
CHECKED - RDP 01/26
DRAWN - NHC 01/26
CHECKED - ELH 01/26

REVISED -
REVISED -
REVISED -
REVISED -

**STATE OF ILLINOIS
DEPARTMENT OF TRANSPORTATION**

**BEARING DETAILS
SN 058-0068 (WB) & SN 058-0069 (EB)**

SHEET 15 OF 33 SHEETS

F.A.I. RTE.	SECTION	COUNTY	TOTAL SHEETS	SHEET NO.
72	D7 BRIDGE REPAIRS 2026-3	MACON	108	54
ILLINOIS FED. AID PROJECT				

SN 058-0068 & SN 058-0069

BILL OF MATERIAL

Item	Unit	Total
Elastomeric Bearing Assembly, Type I	Each	36
Anchor Bolts, 1"	Each	64
Jack and Remove Existing Bearings	Each	36
Furnishing and Erecting Structural Steel	Pound	8,087

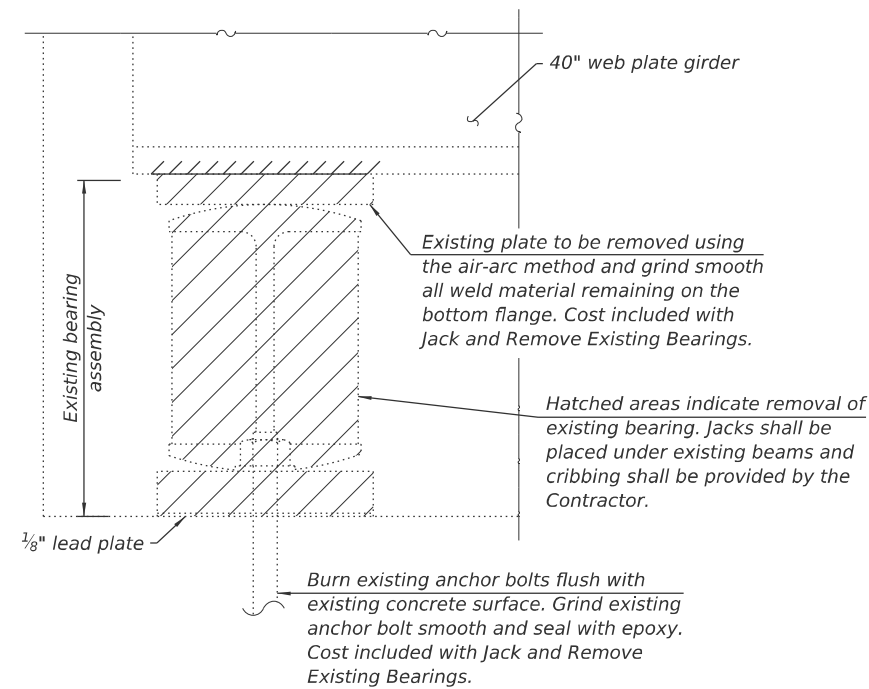

EXISTING BEARING REMOVAL DETAIL

Notes:

Prior to ordering any material, the Contractor shall verify in the field all bearing height and shim thickness dimensions.

Side retainers and stainless steel plates shall be included in the cost of Elastomeric Bearing Assembly, Type I.

The cost of new steel extensions, shim plates, connection bolts through the girder flanges, and field drilling holes in the girder bottom flanges are included with Furnishing and Erecting Structural Steel.

Minimum jack capacity = 70 Ton.

Two 1/8 inch adjusting shims shall be provided for each bearing in addition to all other plates or shims and placed as shown on bearing details.

Drilled and set anchor bolts shall be installed according to Article 521.06 of the Standard Specifications.

For layout of side retainers, see Abutment Repairs Sheets 21 and 22 of 33.

Girder surfaces where the paint has been removed shall be spot cleaned and painted with an aluminum epoxy mastic primer followed by a finish coat to match the color of the existing girder. Cost of spot cleaning and painting is included with Jack and Remove Existing Bearings.

Numerous shim plates are required to match the existing bearing assembly heights. Many of the shim plates are tapered. See Shim Plate Tables for dimensions.

MODEL: Sheet
FILE NAME: Y:\IDOT\1445-01_74D08\74D08 DESIGN\CADD\SP SN 058-0068-0069\Common sheets\0580068-D774D08-16-BearingDtls.dgn

(Sheet 2 of 2)



USER NAME = nhc	DESIGNED - ELH 07/25	REVISED -
ESCA PROJECT NO. = 1445.01	CHECKED - RDP 07/25	REVISED -
PLOT SCALE = 0.2" / in.	DRAWN - NHC 07/25	REVISED -
PLOT DATE = 1/20/2026	CHECKED - ELH 07/25	REVISED -

**STATE OF ILLINOIS
DEPARTMENT OF TRANSPORTATION**

**BEARING DETAILS
SN 058-0068 (WB) & SN 058-0069 (EB)**

SHEET 16 OF 33 SHEETS

F.A.I. RTE.	SECTION	COUNTY	TOTAL SHEETS	SHEET NO.
72	D7 BRIDGE REPAIRS 2026-3	MACON	108	55
CONTRACT NO. 74D08				
ILLINOIS FED. AID PROJECT				

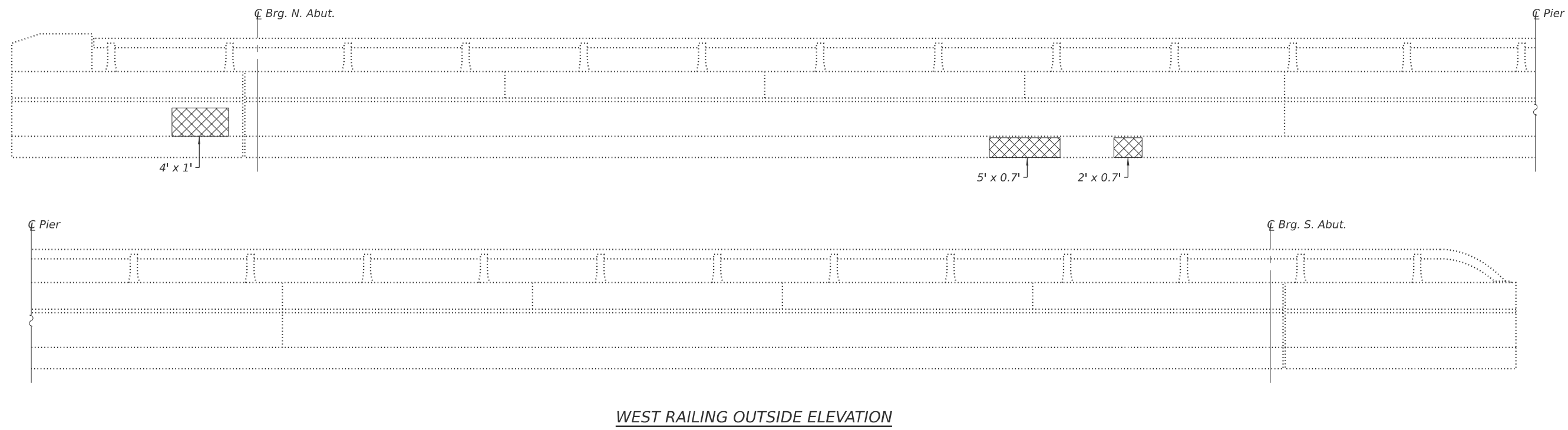
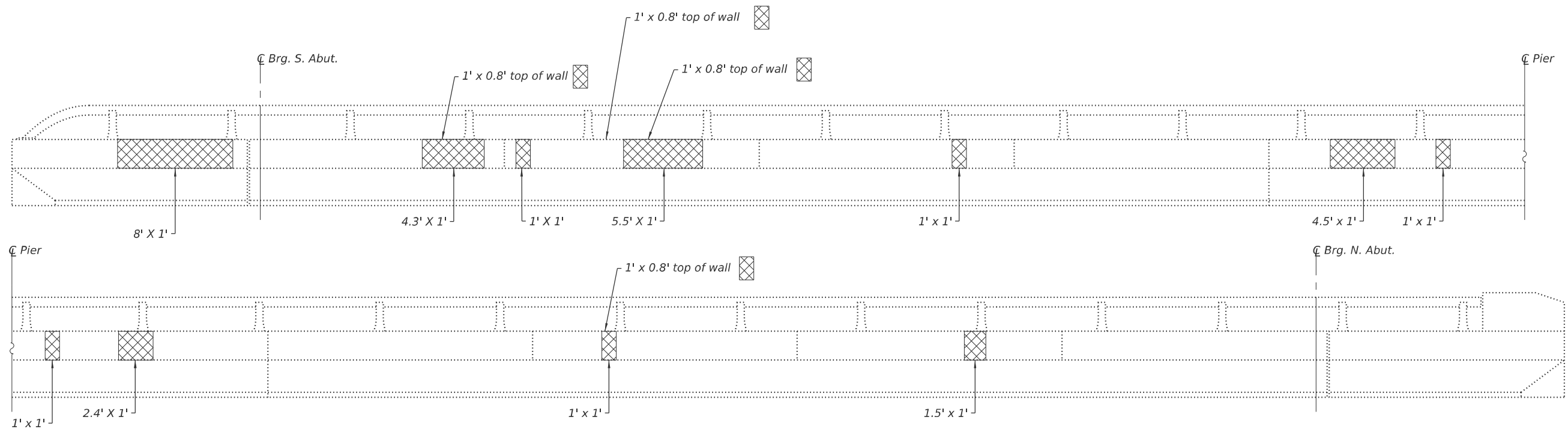

LEGEND
 Structural Repair of Concrete (Depth Equal to or Less Than 5 Inches)

MODEL: Sheet
 FILE NAME: Y:\IDOT\1445-01_74D08\74D08 DESIGN\CADD\SP SN 058-0068-0069\Common sheets\0580068-D74D08-17-ParapetRepairs(WB).dgn
 1/20/2026 10:00:42 AM

(Sheet 1 of 4)



USER NAME = nhc
 ESCA PROJECT NO. = 1445.01
 PLOT SCALE = 0.2" / in.
 PLOT DATE = 1/20/2026

DESIGNED - ELH 07/25
 CHECKED - RDP 07/25
 DRAWN - NHC/ZTC 07/25
 CHECKED - ELH 07/25

REVISED -
 REVISED -
 REVISED -
 REVISED -

STATE OF ILLINOIS
DEPARTMENT OF TRANSPORTATION

PARAPET REPAIRS
SN 058-0068 (WB)

SHEET 17 OF 33 SHEETS

F.A.I. RTE.	SECTION	COUNTY	TOTAL SHEETS	SHEET NO.
72	D7 BRIDGE REPAIRS 2026-3	MACON	108	56
CONTRACT NO. 74D08				

ILLINOIS FED. AID PROJECT

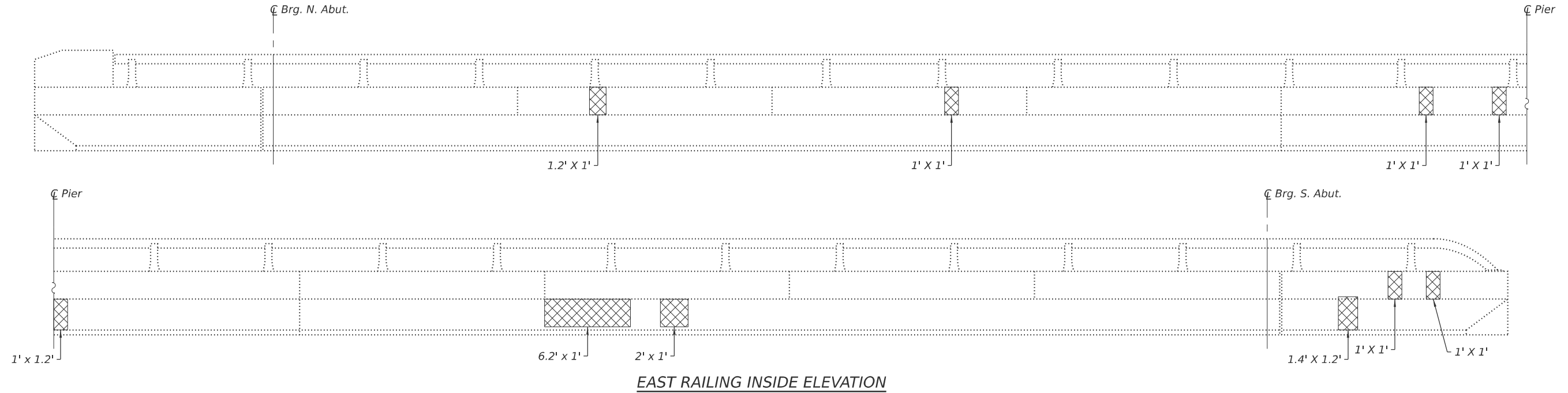

EAST RAILING INSIDE ELEVATION

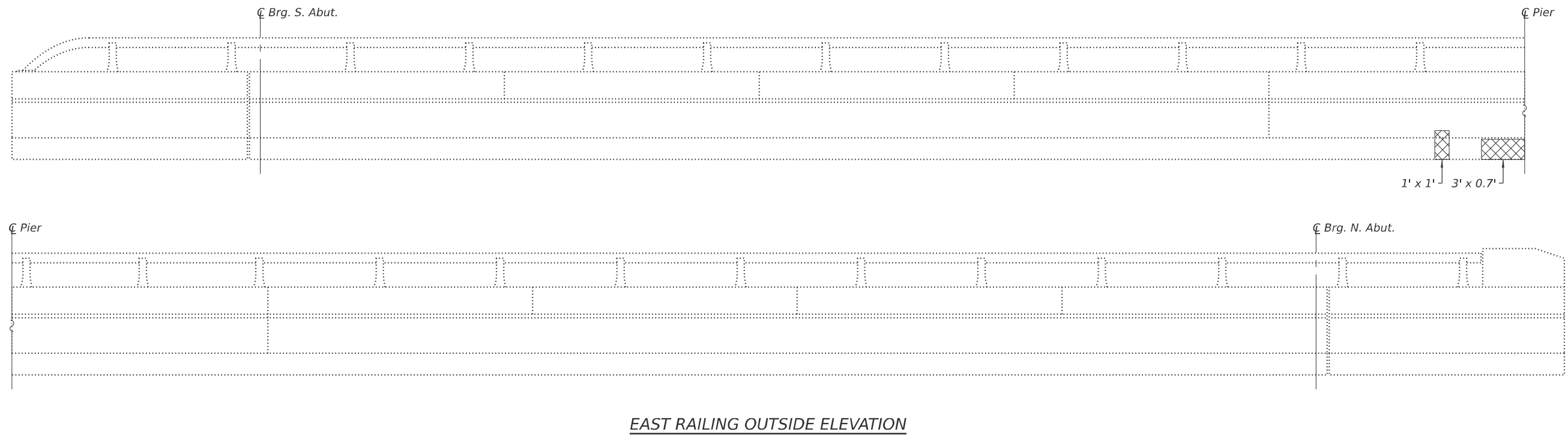

EAST RAILING OUTSIDE ELEVATION

LEGEND

 Structural Repair of Concrete (Depth Equal to or Less Than 5 Inches)

SN 058-0068 BILL OF MATERIAL

Item	Unit	Quantity
Structural Repair of Concrete (Depth Equal to or Less Than 5 Inches)	Sq. Ft.	63.7

(Sheet 2 of 4)

MODEL: Sheet
FILE NAME: Y:\DOT\1445-01_74D08\74D08 DESIGN\CADD\SP SN 058-0068-0069\Common sheets\0580068-D74D08-18-ParapetRepairs(WB).dgn



USER NAME = nhc
ESCA PROJECT NO. = 1445.01
PLOT SCALE = 0.2" / in.
PLOT DATE = 1/20/2026

DESIGNED - ELH 07/25
CHECKED - RDP 07/25
DRAWN - NHC/ZTC 07/25
CHECKED - ELH 07/25

REVISED -
REVISED -
REVISED -
REVISED -

**STATE OF ILLINOIS
DEPARTMENT OF TRANSPORTATION**

**PARAPET REPAIRS
SN 058-0068 (WB)**

SHEET 18 OF 33 SHEETS

F.A.I. RTE.	SECTION	COUNTY	TOTAL SHEETS	SHEET NO.
72	D7 BRIDGE REPAIRS 2026-3	MACON	108	57
CONTRACT NO. 74D08				
ILLINOIS FED. AID PROJECT				

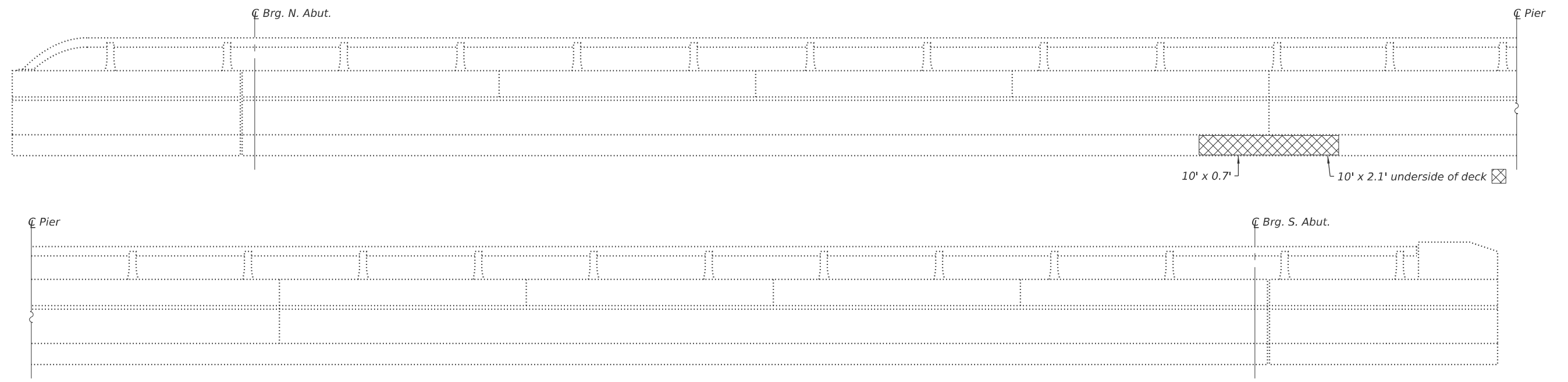
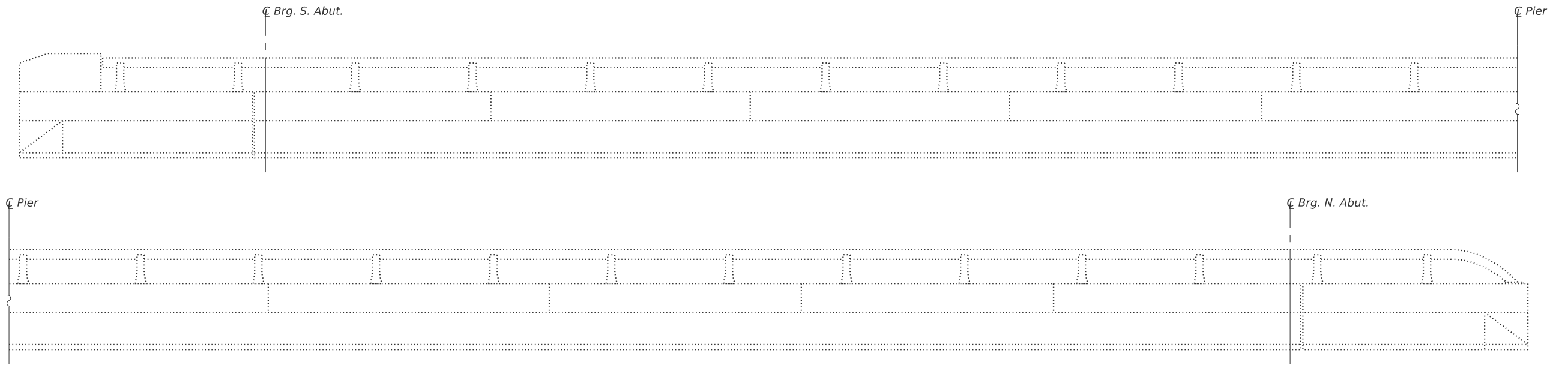

LEGEND
 Structural Repair of Concrete (Depth Equal to or Less Than 5 Inches)

MODEL: Sheet
 FILE NAME: Y:\DOT\1445-01_74D08\74D08 DESIGN\CADD\SP SN 058-0069\069\Common sheets\0580068-D74D08-19-ParapetRepairs(EB).dgn
 1/20/2026 10:00:43 AM



USER NAME = nhc	DESIGNED - ELH 07/25	REVISED -
ESCA PROJECT NO. = 1445.01	CHECKED - RDP 07/25	REVISED -
PLOT SCALE = 0.2" / in.	DRAWN - NHC/ZTC 07/25	REVISED -
PLOT DATE = 1/20/2026	CHECKED - ELH 07/25	REVISED -

**STATE OF ILLINOIS
 DEPARTMENT OF TRANSPORTATION**

(Sheet 3 of 4)

**PARAPET REPAIRS
 SN 058-0069 (EB)**

SHEET 19 OF 33 SHEETS

F.A.I. RTE.	SECTION	COUNTY	TOTAL SHEETS	SHEET NO.
72	D7 BRIDGE REPAIRS 2026-3	MACON	108	58
CONTRACT NO. 74D08				
		ILLINOIS	FED. AID PROJECT	

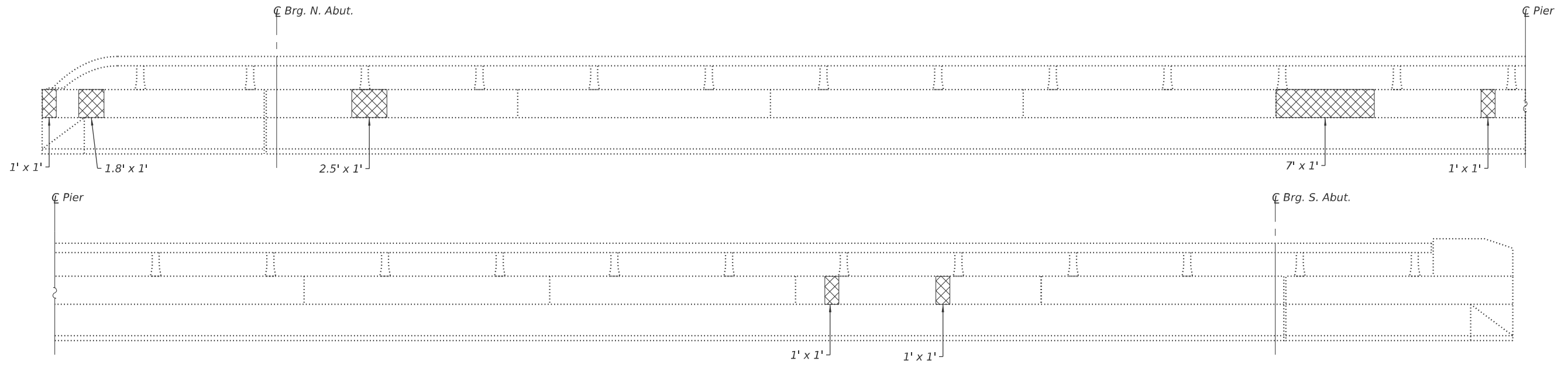

EAST RAILING INSIDE ELEVATION

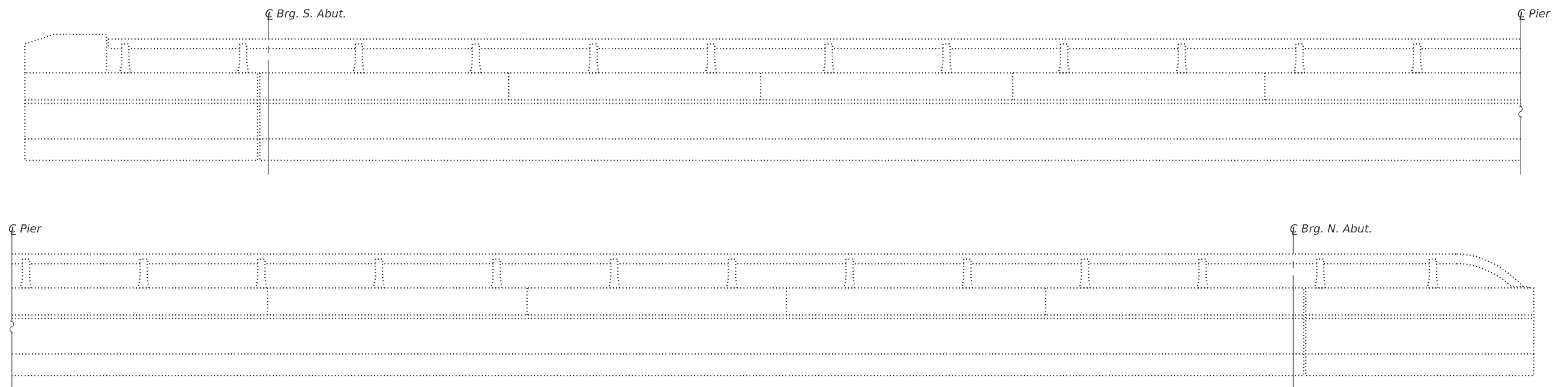

EAST RAILING OUTSIDE ELEVATION

LEGEND

 Structural Repair of Concrete (Depth Equal to or Less Than 5 Inches)

SN 058-0069 BILL OF MATERIAL

Item	Unit	Quantity
Structural Repair of Concrete (Depth Equal to or Less Than 5 Inches)	Sq. Ft.	43.3

(Sheet 4 of 4)

MODEL: Sheet
FILE NAME: Y:\DOT\1445-01_74D08\74D08 DESIGN\CADD\SP SN 058-0069-0069\Common sheets\0580068-D74D08-20-ParapetRepairs(EB).dgn



USER NAME = nhc	DESIGNED - ELH 07/25	REVISED -
ESCA PROJECT NO. = 1445.01	CHECKED - RDP 07/25	REVISED -
PLOT SCALE = 0.2" / in.	DRAWN - NHC/ZTC 07/25	REVISED -
PLOT DATE = 1/20/2026	CHECKED - ELH 07/25	REVISED -

**STATE OF ILLINOIS
DEPARTMENT OF TRANSPORTATION**

**PARAPET REPAIRS
SN 058-0069 (EB)**

SHEET 20 OF 33 SHEETS

F.A.I. RTE.	SECTION	COUNTY	TOTAL SHEETS	SHEET NO.
72	D7 BRIDGE REPAIRS 2026-3	MACON	108	59
CONTRACT NO. 74D08				
ILLINOIS FED. AID PROJECT				

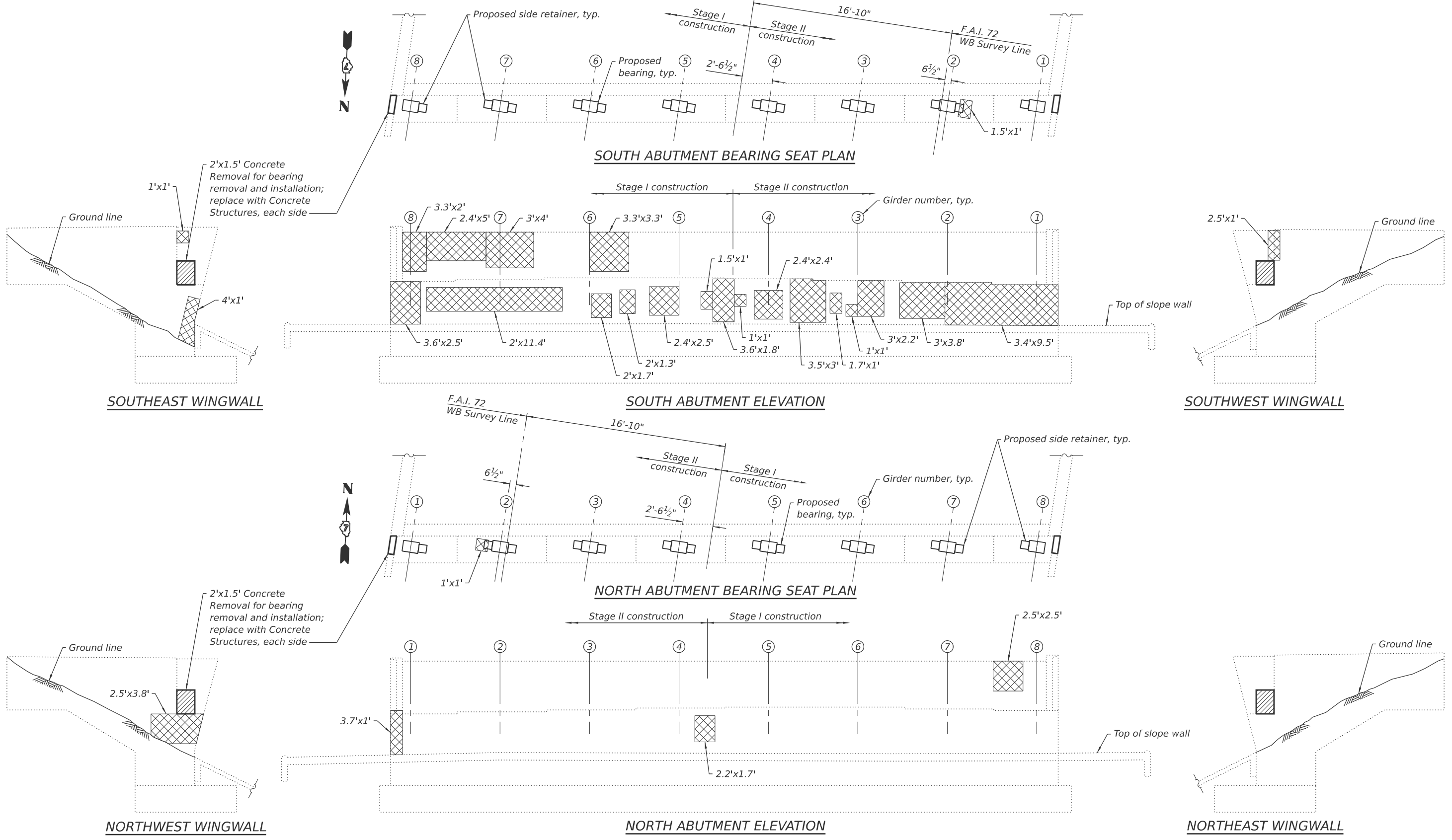

SOUTHEAST WINGWALL

SOUTH ABUTMENT BEARING SEAT PLAN

SOUTH ABUTMENT ELEVATION

SOUTHWEST WINGWALL

NORTH ABUTMENT BEARING SEAT PLAN

NORTH ABUTMENT ELEVATION

NORTHWEST WINGWALL

NORTHEAST WINGWALL

SN 058-0068 BILL OF MATERIAL

Item	Unit	Quantity
Structural Repair of Concrete (Depth Equal to or Less Than 5 Inches)	Sq. Ft.	196.7
Concrete Removal	Cu. Yd.	0.3
Concrete Structures	Cu. Yd.	0.3

Note:
1. Abutment repairs shall be staged according to the same dimensions and locations as shown for the superstructure.

LEGEND

	Structural Repair of Concrete (Depth Equal to or Less Than 5 Inches)
--	--

(Sheet 1 of 2)

STATE OF ILLINOIS
DEPARTMENT OF TRANSPORTATION

ABUTMENT REPAIRS
SN 058-0068 (WB)

SHEET 21 OF 33 SHEETS

F.A.I. RTE.	SECTION	COUNTY	TOTAL SHEETS	SHEET NO.
72	D7 BRIDGE REPAIRS 2026-3	MACON	108	60
CONTRACT NO. 74D08				
ILLINOIS FED. AID PROJECT				

MODEL: Sheet
FILE NAME: Y:\DOT\1445-01_74D08\74D08 DESIGN\CADD\SP SN 058-0068-0069\Common sheets\0580068-D774D08-21-AbutRepairs(WB).dgn



USER NAME = nhc	DESIGNED - ELH 07/25	REVISED -
ESCA PROJECT NO. = 1445.01	CHECKED - RDP 07/25	REVISED -
PLOT SCALE = 0.2" = 1' / in.	DRAWN - NHC 01/26	REVISED -
PLOT DATE = 1/20/2026	CHECKED - ELH 01/26	REVISED -

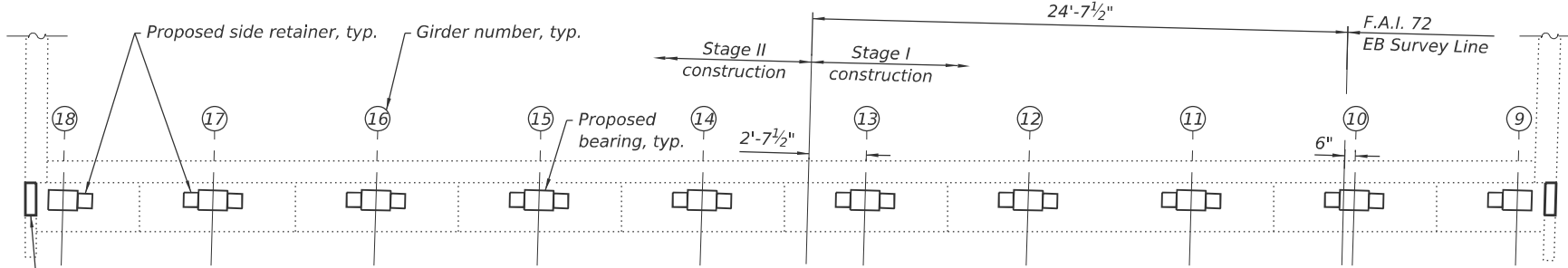

SOUTH ABUTMENT BEARING SEAT PLAN

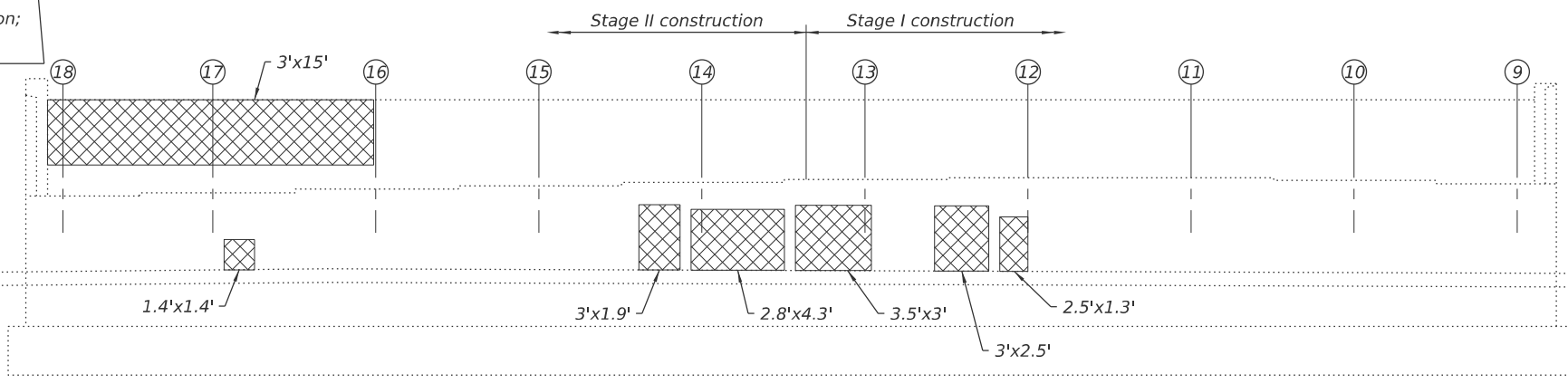

SOUTH ABUTMENT ELEVATION

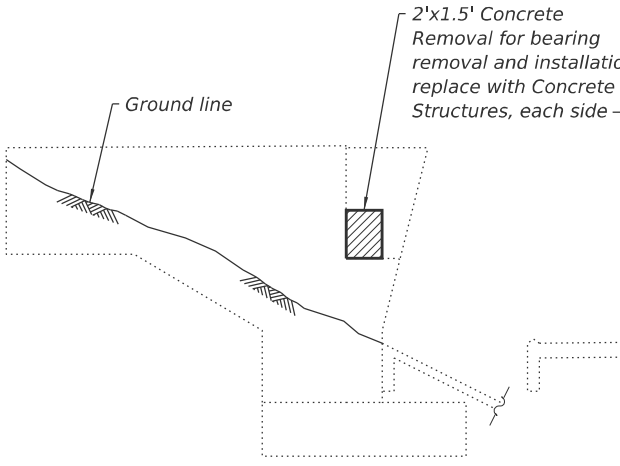

SOUTHEAST WINGWALL

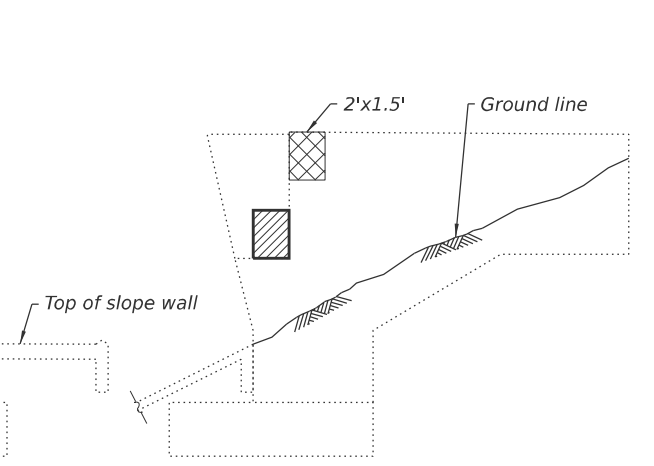

SOUTHWEST WINGWALL

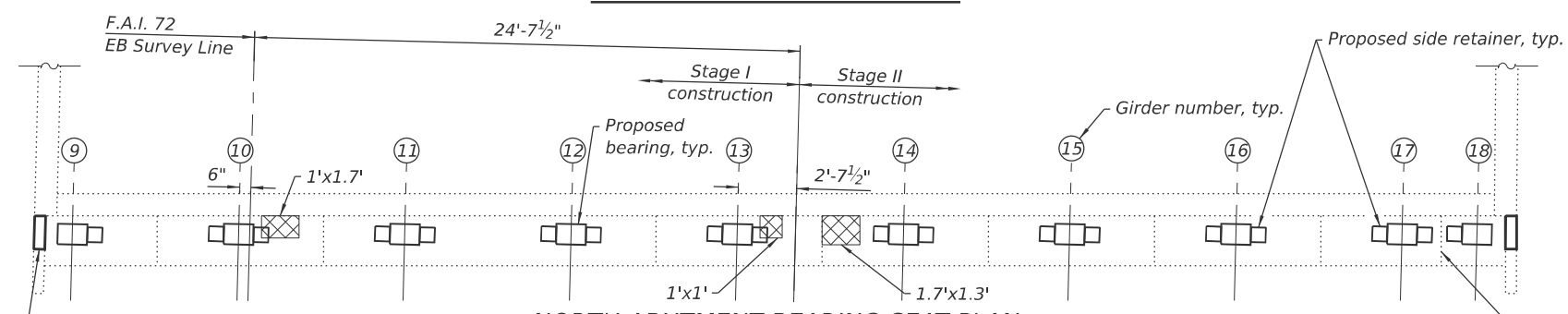

NORTH ABUTMENT BEARING SEAT PLAN

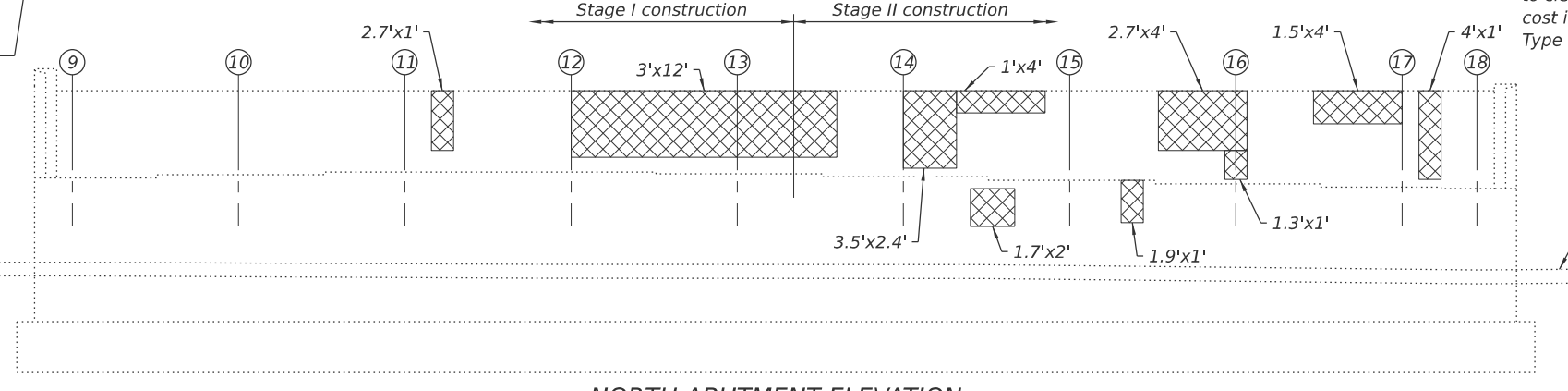

NORTH ABUTMENT ELEVATION

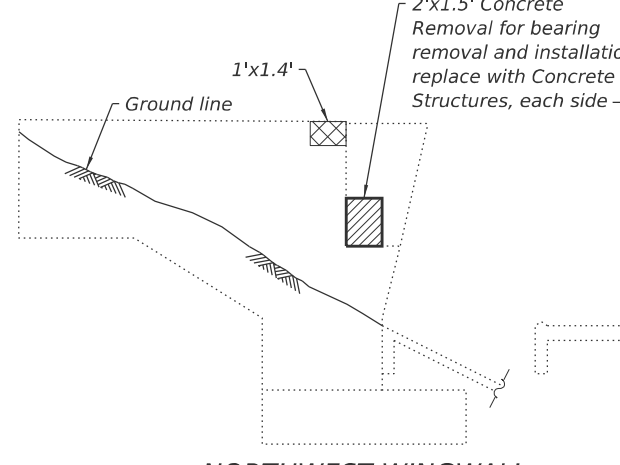

NORTHWEST WINGWALL

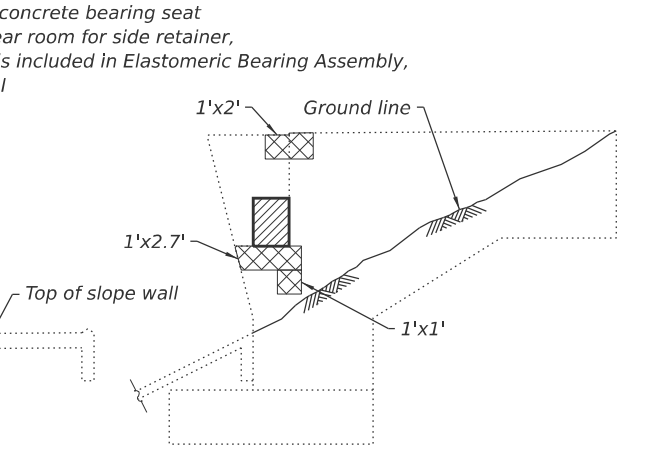

NORTHEAST WINGWALL

Note:
1. Abutment repairs shall be staged according to the same dimensions and locations as shown for the superstructure.

LEGEND

Structural Repair of Concrete (Depth Equal to or Less Than 5 Inches)

SN 058-0069 BILL OF MATERIAL

Item	Unit	Quantity
Structural Repair of Concrete (Depth Equal to or Less Than 5 Inches)	Sq. Ft.	179.5
Concrete Removal	Cu. Yd.	0.3
Concrete Structures	Cu. Yd.	0.3

(Sheet 2 of 2)

MODEL: Sheet
FILE NAME: Y:\DOT\1445-01_74D08\74D08 DESIGN\CADD\SP SN 058-0069-0069\Common sheets\0580068-D774D08-22-AbutmentRepairs(EB).dgn



USER NAME = nhc	DESIGNED - ELH 07/25	REVISED -
ESCA PROJECT NO. = 1445.01	CHECKED - RDP 07/25	REVISED -
PLOT SCALE = 0.2" / in.	DRAWN - NHC 07/25	REVISED -
PLOT DATE = 1/20/2026	CHECKED - ELH 07/25	REVISED -

**STATE OF ILLINOIS
DEPARTMENT OF TRANSPORTATION**

**ABUTMENT REPAIRS
SN 058-0069 (EB)**

SHEET 22 OF 33 SHEETS

F.A.I. RTE.	SECTION	COUNTY	TOTAL SHEETS	SHEET NO.
72	D7 BRIDGE REPAIRS 2026-3	MACON	108	61
CONTRACT NO. 74D08				
ILLINOIS FED. AID PROJECT				

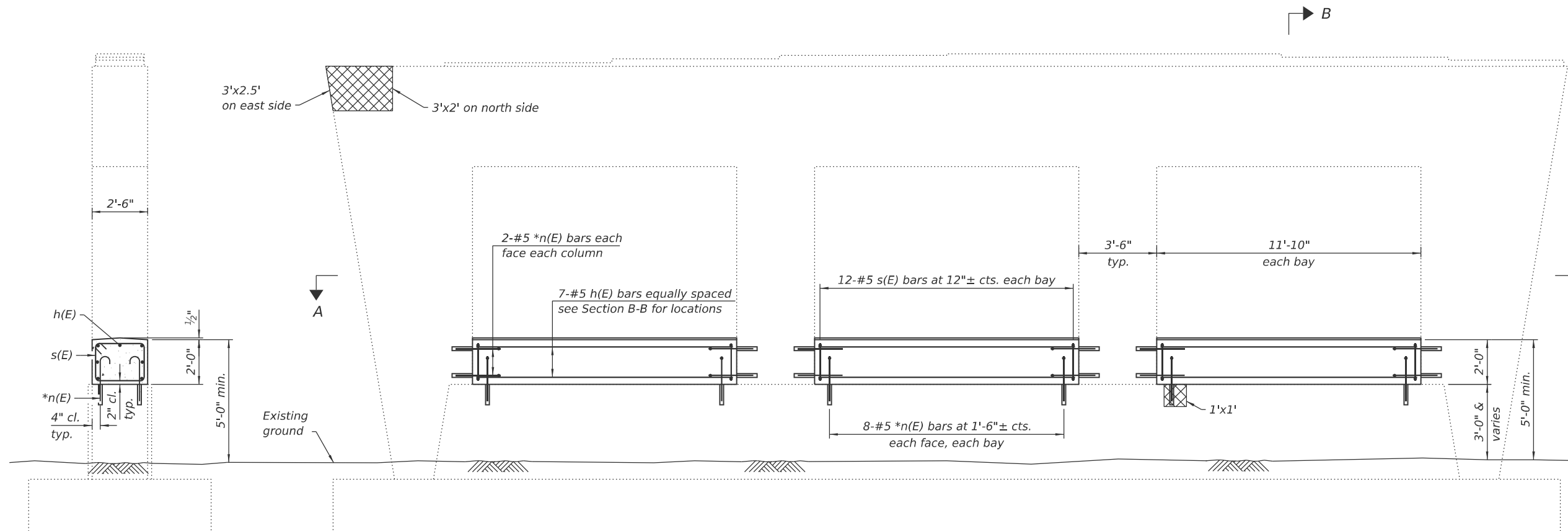

SECTION B-B

ELEVATION
(Looking North)

*Epoxy grout n(E) bars in 9" min. holes according to Article 584 of the Standard Specifications. Adjust locations to clear existing reinforcement. Cost is included in Reinforcement Bars, Epoxy Coated.

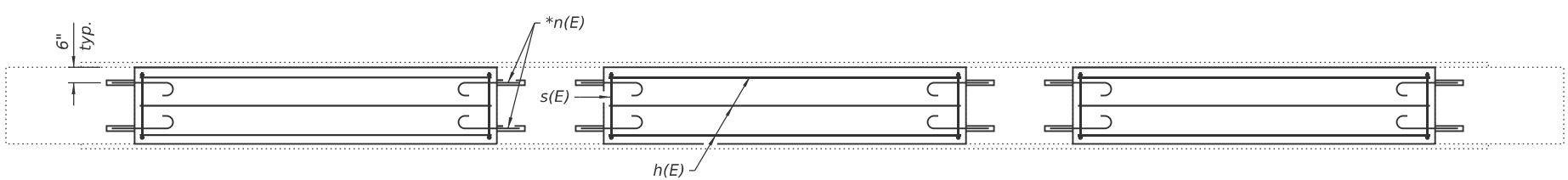

SECTION A-A



LEGEND

Structural Repair of Concrete (Depth Equal to or Less Than 5 Inches)

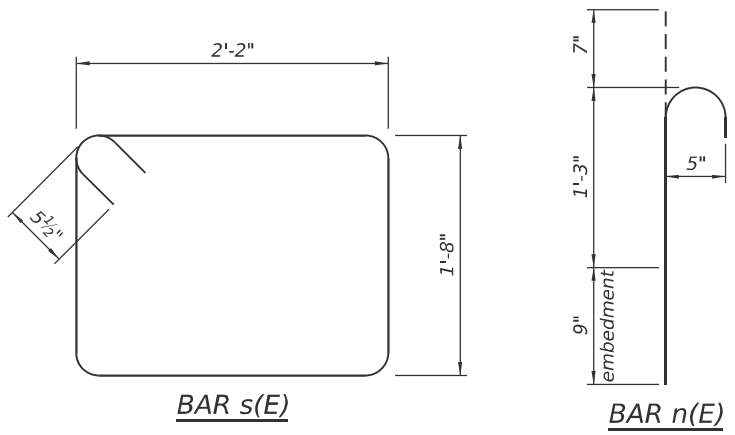

SN 058-0068 BILL OF MATERIAL

Bar	No.	Size	Length	Shape	
h(E)	21	#5	11'-6"	—	
n(E)	72	#5	2'-7"	U	
s(E)	36	#5	8'-7"	□	
Concrete Structures				Cu. Yd.	6.7
Reinforcement Bars, Epoxy Coated				Pound	770
Structural Repair of Concrete (Depth Equal to or Less Than 5 Inches)				Sq. Ft.	14.5

(Sheet 1 of 2)



USER NAME = nhc	DESIGNED - ELH 07/25	REVISED -
ESCA PROJECT NO. = 1445.01	CHECKED - RDP 07/25	REVISED -
PLOT SCALE = 0:2" / in.	DRAWN - NHC 07/25	REVISED -
PLOT DATE = 1/20/2026	CHECKED - ELH 07/25	REVISED -

STATE OF ILLINOIS
DEPARTMENT OF TRANSPORTATION

PIER REPAIRS
SN 058-0068 (WB)

F.A.I. RTE.	SECTION	COUNTY	TOTAL SHEETS	SHEET NO.
72	D7 BRIDGE REPAIRS 2026-3	MACON	108	62
CONTRACT NO. 74D08				
ILLINOIS FED. AID PROJECT				

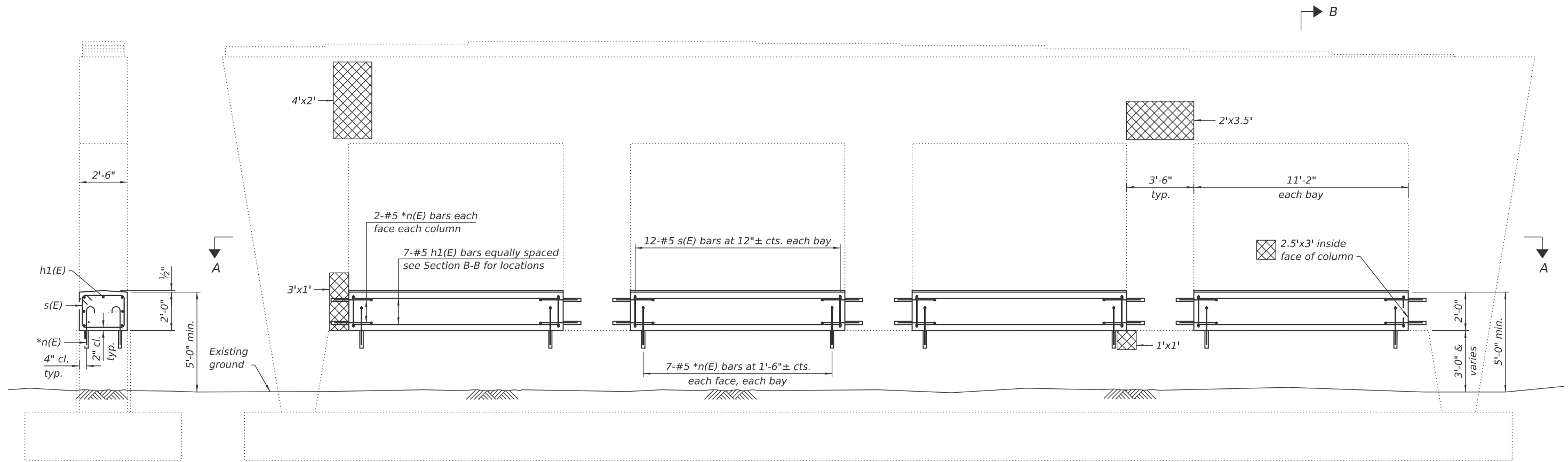

SECTION B-B

ELEVATION
(Looking North)

*Epoxy grout n(E) bars in 9" min. holes according to Article 584 of the Standard Specifications. Adjust locations to clear existing reinforcement. Cost is included in Reinforcement Bars, Epoxy Coated.

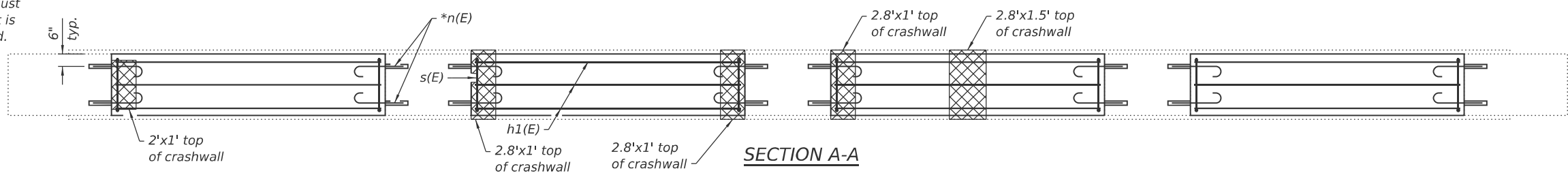

SECTION A-A

LEGEND

Structural Repair of Concrete (Depth Equal to or Less Than 5 Inches)

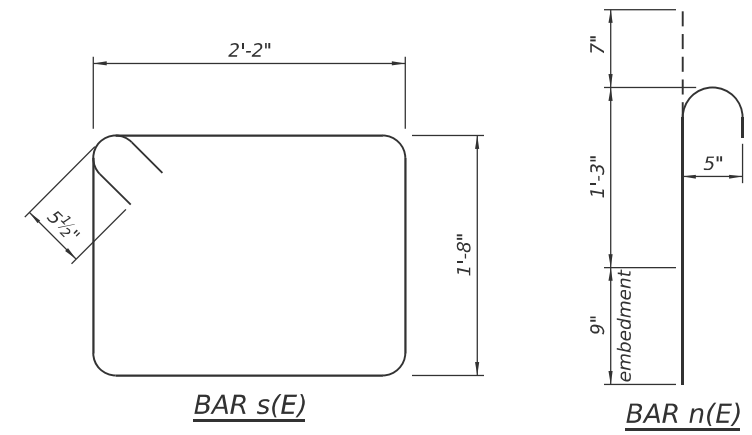

BAR s(E)

BAR n(E)

SN 058-0069 BILL OF MATERIAL

Bar	No.	Size	Length	Shape	
h1(E)	28	#5	10'-10"	—	
n(E)	88	#5	2'-7"	U	
s(E)	48	#5	8'-7"	□	
Concrete Structures				Cu. Yd.	8.4
Reinforcement Bars, Epoxy Coated				Pound	990
Structural Repair of Concrete (Depth Equal to or Less Than 5 Inches)				Sq. Ft.	41.1

(Sheet 2 of 2)

MODEL: Sheet
FILE NAME: Y:\DOT11445-01_74D0874D08 DESIGN\CADD\SP_SN_058-0068-0069\Common sheets\0580068-D774D08-24-PierRepairs(EB).dgn



USER NAME = nhc
ESCA PROJECT NO. = 1445.01
PLOT SCALE = 0.2" / in.
PLOT DATE = 1/20/2026

DESIGNED - ELH 07/25
CHECKED - RDP 07/25
DRAWN - NHC 07/25
CHECKED - ELH 07/25

REVISED -
REVISED -
REVISED -
REVISED -

**STATE OF ILLINOIS
DEPARTMENT OF TRANSPORTATION**

**PIER REPAIRS
SN 058-0069 (EB)**

SHEET 24 OF 33 SHEETS

F.A.I. RTE.	SECTION	COUNTY	TOTAL SHEETS	SHEET NO.
72	D7 BRIDGE REPAIRS 2026-3	MACON	108	63
CONTRACT NO. 74D08				
ILLINOIS FED. AID PROJECT				

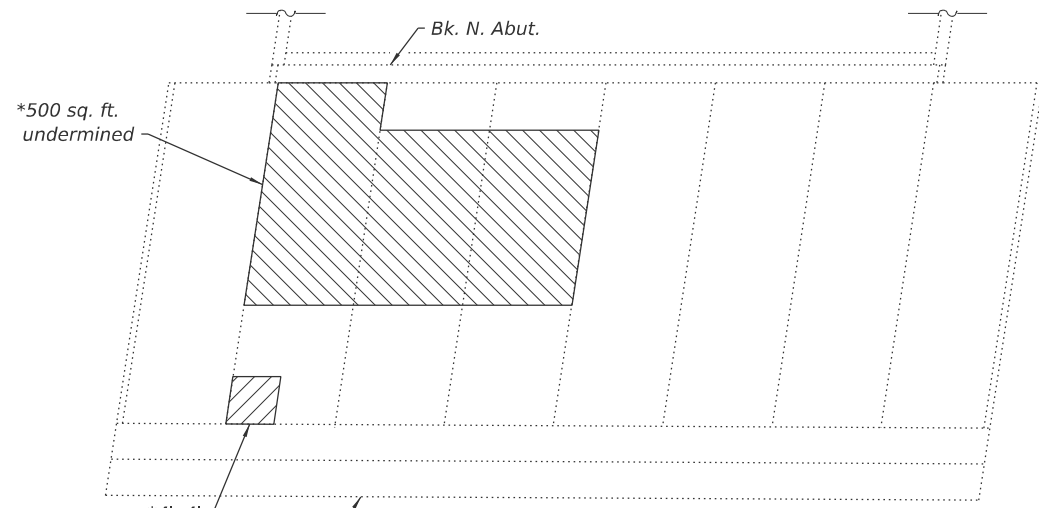

NORTH SLOPE WALL PLAN

Concrete gutter

*Along slope

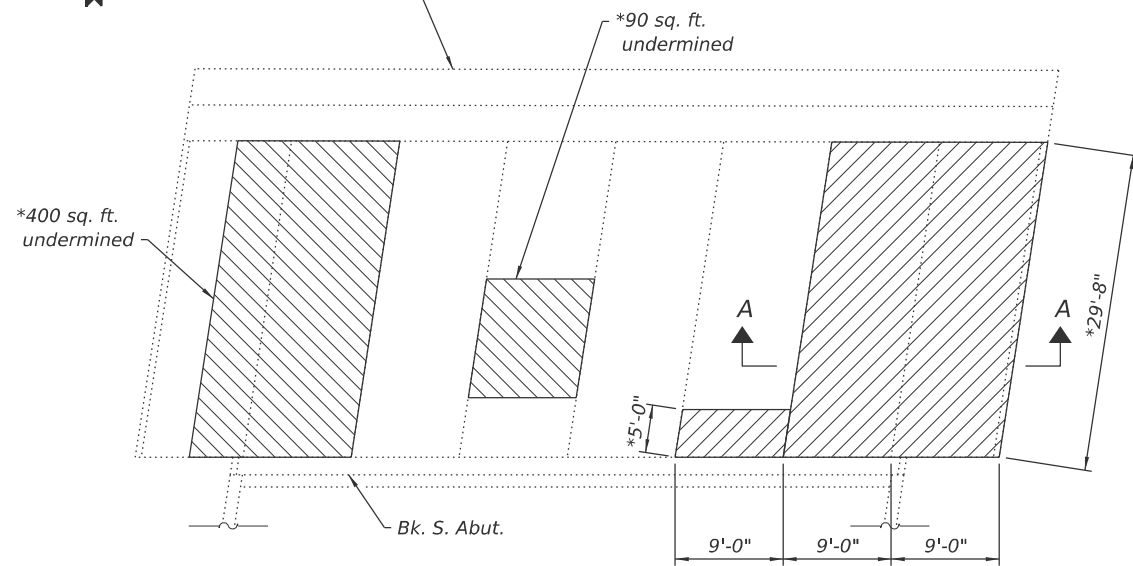

SOUTH SLOPE WALL PLAN

LEGEND

- Slope Wall Repair
- Slope Wall Slurry Pumping

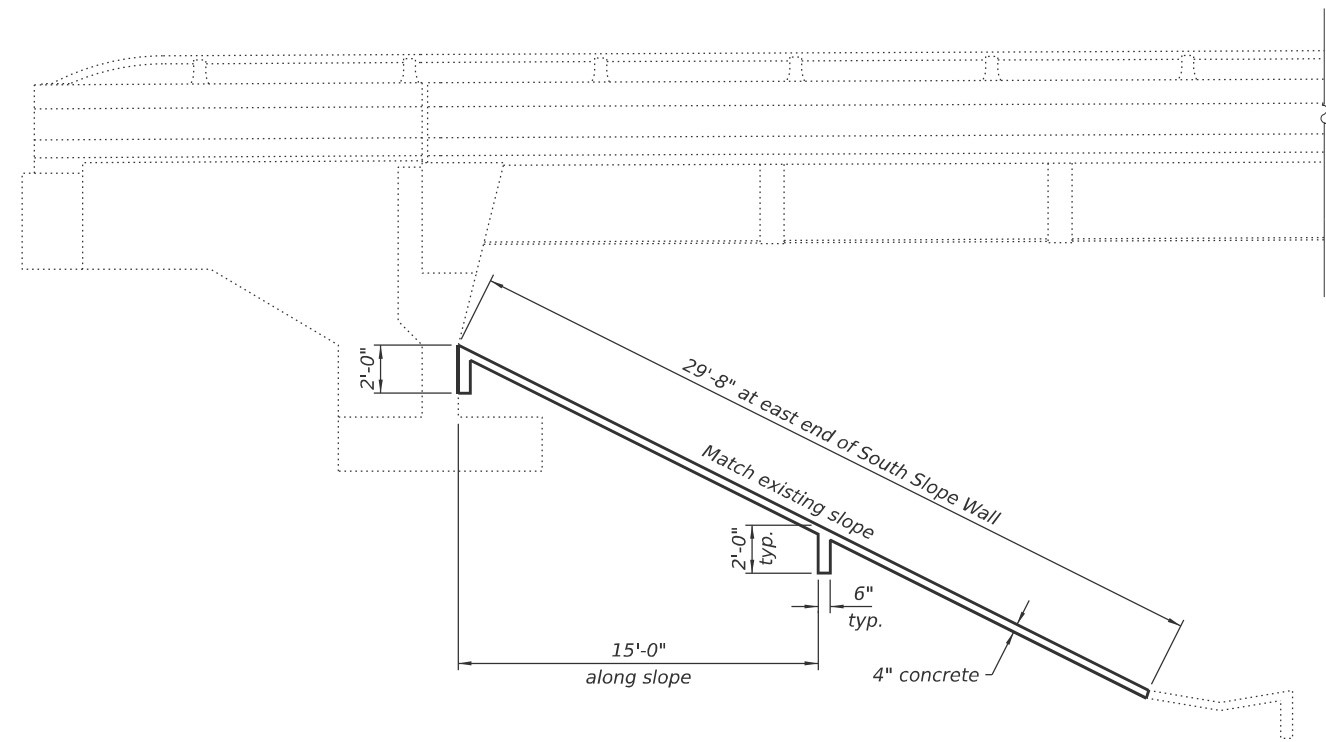

ELEVATION VIEW
(Showing Slope Wall Repair)

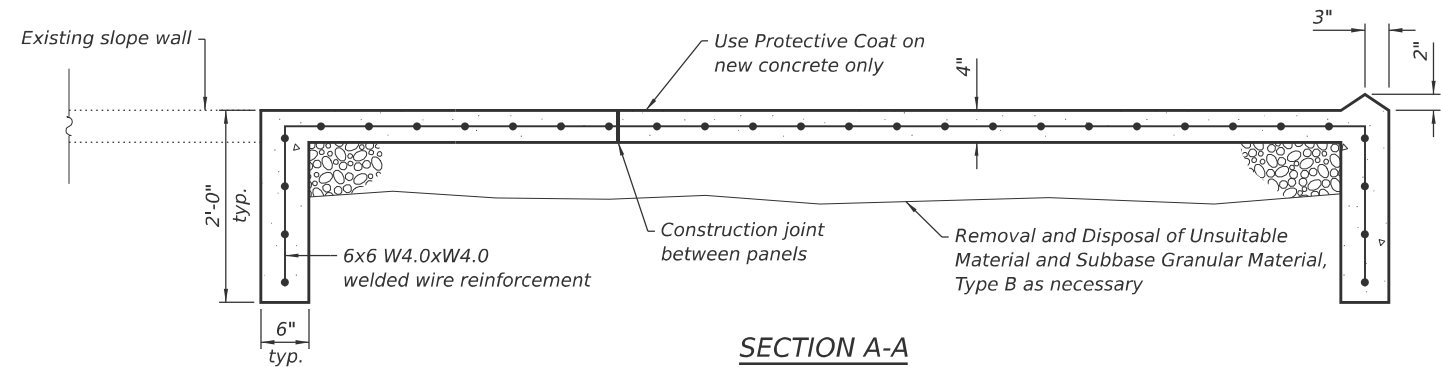

SECTION A-A

Notes:

1. Prior to partial removal of slope wall, a $\frac{3}{4}$ " deep saw cut shall be made along all boundaries of the removal areas. Saw cuts will be included in the cost of Slope Wall Repair.
2. The existing riprap and other unsuitable embankment material shall be removed as directed by the Engineer. The removal will be paid for as Removal and Disposal of Unsuitable Materials. In these areas the embankment shall be reconstructed with Subbase Granular Material, Type B. The Subbase Granular Material shall be gradation CA6 unless otherwise specified by the Engineer.
3. At locations where the concrete slope wall is still intact but has been undermined, Slope Wall Slurry Pumping shall be used to replace the base under the existing slope wall.
4. Quantities and locations are approximated. Actual quantities and locations are to be determined in the field by the Engineer. This work is intended to repair only areas of severe deterioration. Some minor deteriorated areas may be left unrepaired.

SN 058-0068 BILL OF MATERIAL

Item	Unit	Quantity
Slope Wall Repair	Sq. Yd.	66
Slope Wall Slurry Pumping	Cu. Yd.	20
Protective Coat	Sq. Yd.	66
Subbase Granular Material, Type B	Ton	30
Removal and Disposal of Unsuitable Material	Cu. Yd.	15

(Sheet 1 of 2)

STATE OF ILLINOIS
DEPARTMENT OF TRANSPORTATION

SLOPE WALL REPAIRS
SN 058-0068 (WB)

SHEET 25 OF 33 SHEETS

F.A.I. RTE.	SECTION	COUNTY	TOTAL SHEETS	SHEET NO.
72	D7 BRIDGE REPAIRS 2026-3	MACON	108	64
CONTRACT NO. 74D08				
ILLINOIS FED. AID PROJECT				

MODEL: Sheet
FILE NAME: Y:\DOT\1445-01_74D08\74D08 DESIGN\CADD\SP SN 058-0068-0069\Common sheets\0580068-D774D08-25-SlopeWallRepair.dgn



USER NAME = nhc
ESCA PROJECT NO. = 1445.01
PLOT SCALE = 0.2" / in.
PLOT DATE = 1/20/2026

DESIGNED -	ELH	07/25	REVISED -
CHECKED -	RDP	07/25	REVISED -
DRAWN -	NHC	07/25	REVISED -
CHECKED -	ELH	07/25	REVISED -

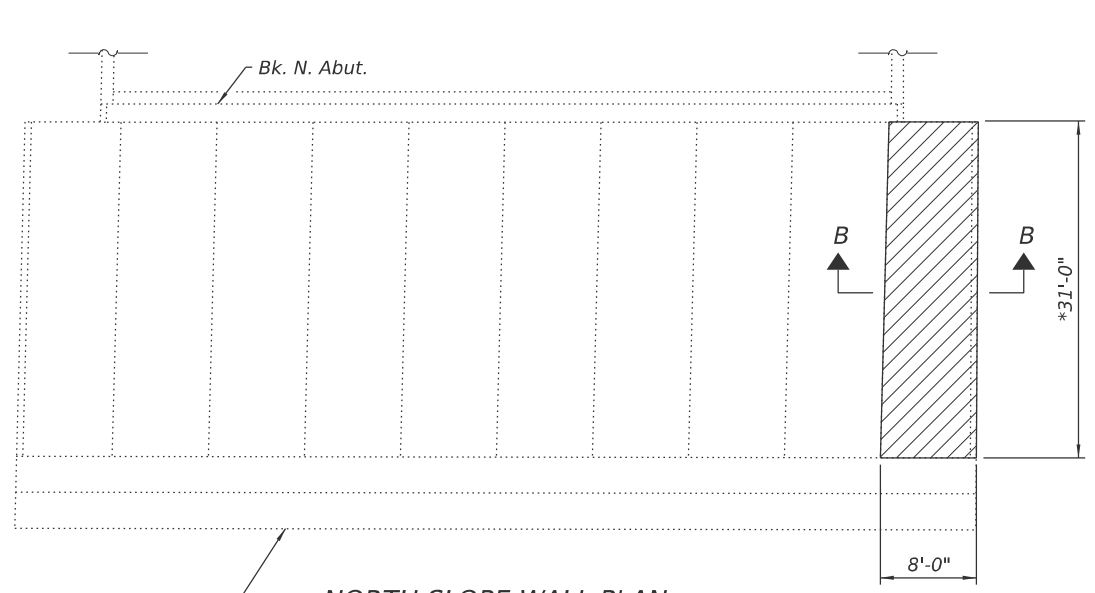

NORTH SLOPE WALL PLAN

Concrete gutter
*Along slope

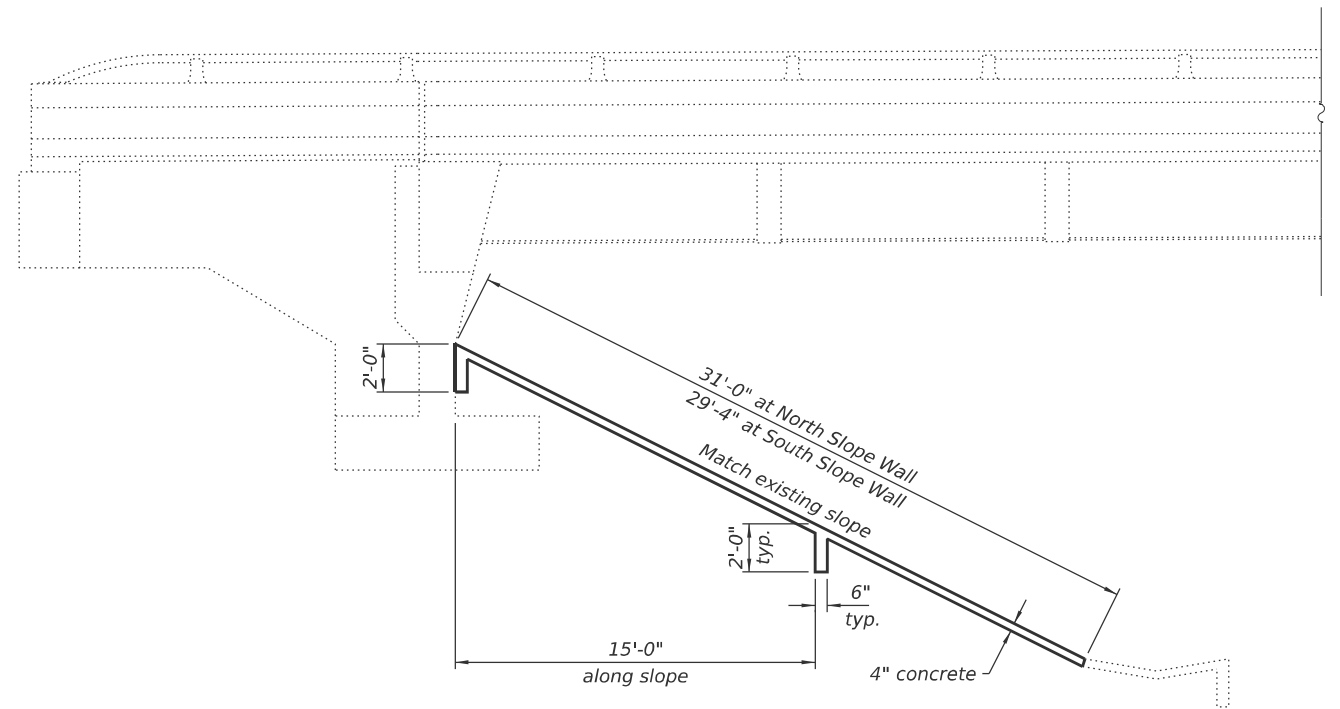

ELEVATION VIEW
(Showing Slope Wall Repair)

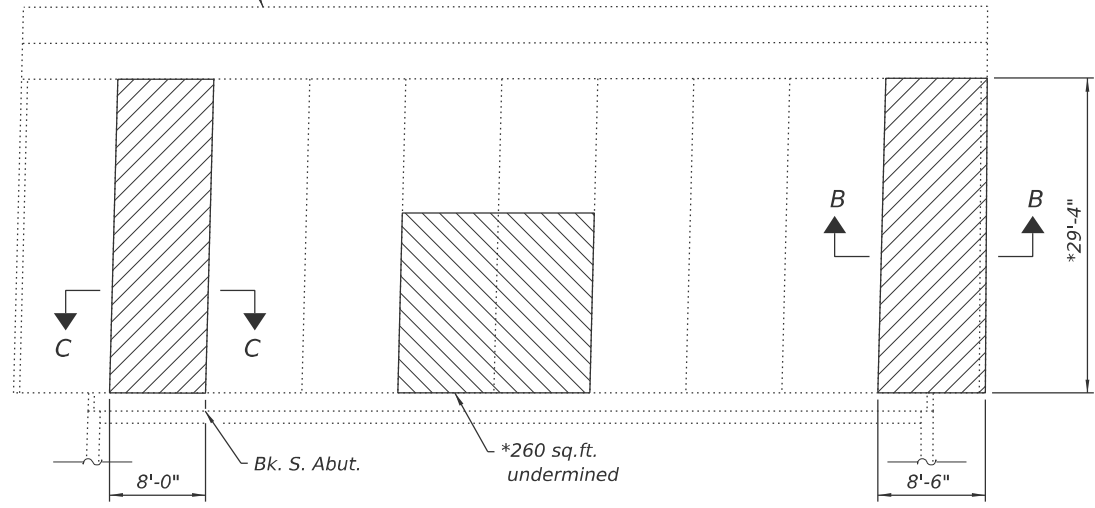

SOUTH SLOPE WALL PLAN

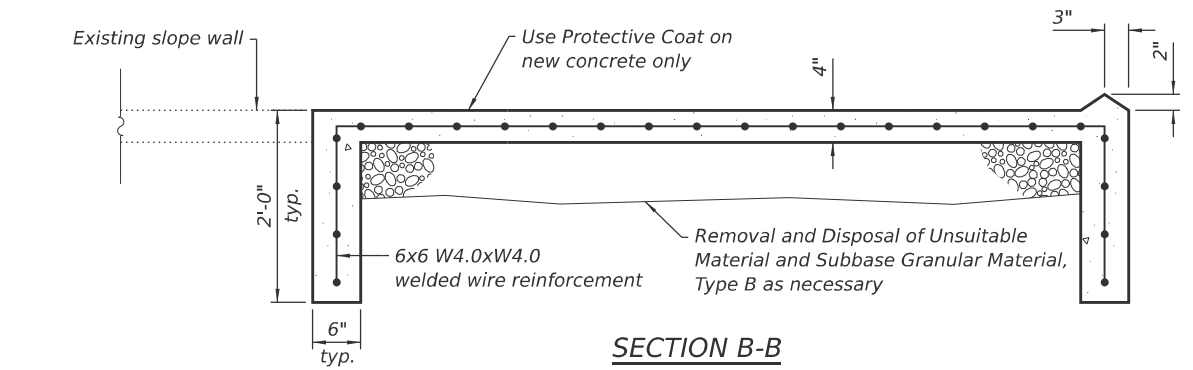

SECTION B-B

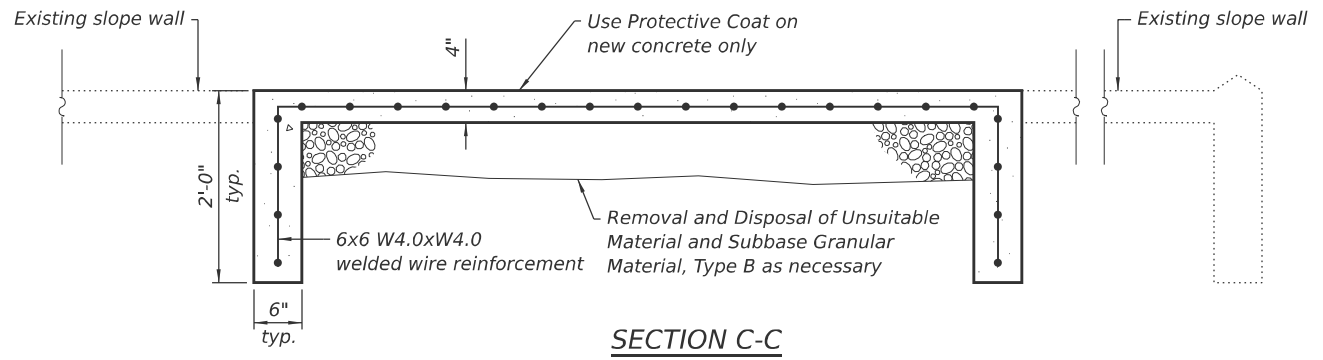

SECTION C-C

- Notes:
1. Prior to partial removal of slope wall, a $\frac{3}{4}$ " deep saw cut shall be made along all boundaries of the removal areas. Saw cuts will be included in the cost of Slope Wall Repair.
 2. The existing riprap and other unsuitable embankment material shall be removed as directed by the Engineer. The removal will be paid for as Removal and Disposal of Unsuitable Materials. In these areas the embankment shall be reconstructed with Subbase Granular Material, Type B. The Subbase Granular Material shall be gradation CA6 unless otherwise specified by the Engineer.
 3. At locations where the concrete slope wall is still intact but has been undermined, Slope Wall Slurry Pumping shall be used to replace the base under the existing slope wall.
 4. Quantities and locations are approximated. Actual quantities and locations are to be determined in the field by the Engineer. This work is intended to repair only areas of severe deterioration. Some minor deteriorated areas may be left unrepaired.

LEGEND

- Slope Wall Repair
- Slope Wall Slurry Pumping

SN 058-0069 BILL OF MATERIAL

Item	Unit	Quantity
Slope Wall Repair	Sq. Yd.	82
Slope Wall Slurry Pumping	Cu. Yd.	5
Protective Coat	Sq. Yd.	82
Subbase Granular Material, Type B	Ton	45
Removal and Disposal of Unsuitable Material	Cu. Yd.	22

(Sheet 2 of 2)

MODEL: Sheet
FILE NAME: Y:\DOT\1445-01_74D08\74D08 DESIGN\CADD\SP SN 058-0068-0069\Common sheets\0580068-D774D08-26-SlopeWallRepair.dgn



USER NAME = nhc	DESIGNED - ELH 07/25	REVISED -
ESCA PROJECT NO. = 1445.01	CHECKED - RDP 07/25	REVISED -
PLOT SCALE = 0.2" = 1' / in.	DRAWN - NHC 07/25	REVISED -
PLOT DATE = 1/20/2026	CHECKED - ELH 07/25	REVISED -

STATE OF ILLINOIS
DEPARTMENT OF TRANSPORTATION

SLOPE WALL REPAIRS
SN 058-0069 (EB)

SHEET 26 OF 33 SHEETS

F.A.I. RTE.	SECTION	COUNTY	TOTAL SHEETS	SHEET NO.
72	D7 BRIDGE REPAIRS 2026-3	MACON	108	65
CONTRACT NO. 74D08				
ILLINOIS FED. AID PROJECT				

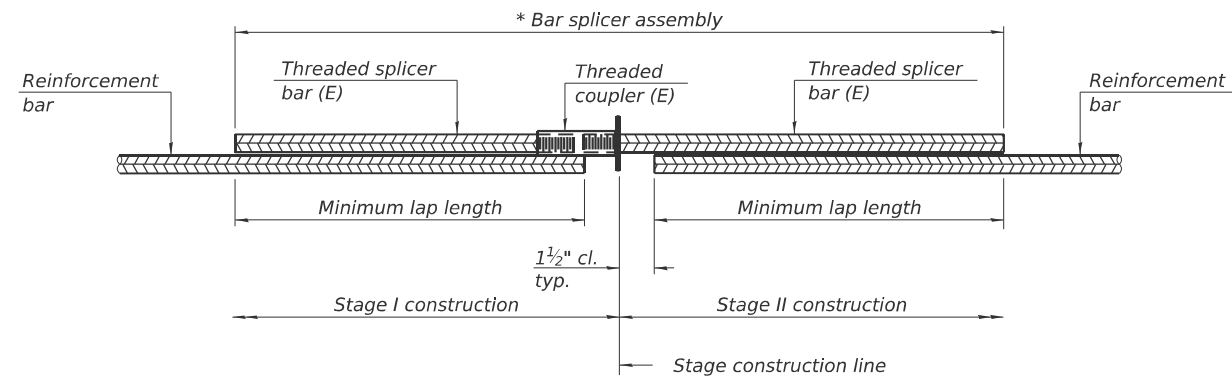

STANDARD BAR SPLICER ASSEMBLY PLAN
 Only bar splicer assemblies as presented on the approved QPL list may be used.

Threaded splicer bar length = min. lap length + 1 1/2" + thread length
 * Epoxy not required on Bar Splicer Assembly components used in conjunction with black bars.

Location	Bar size	No. assemblies required	Minimum lap length
SN 058-0068 Spans 1 & 4 slabs	#5	4	3'-5"
SN 058-0068 Spans 2 & 3 deck	#6	16	5'-3"
SN 058-0069 Spans 1 & 4 slabs	#5	4	3'-5"
SN 058-0069 Spans 2 & 3 deck	#6	16	5'-3"

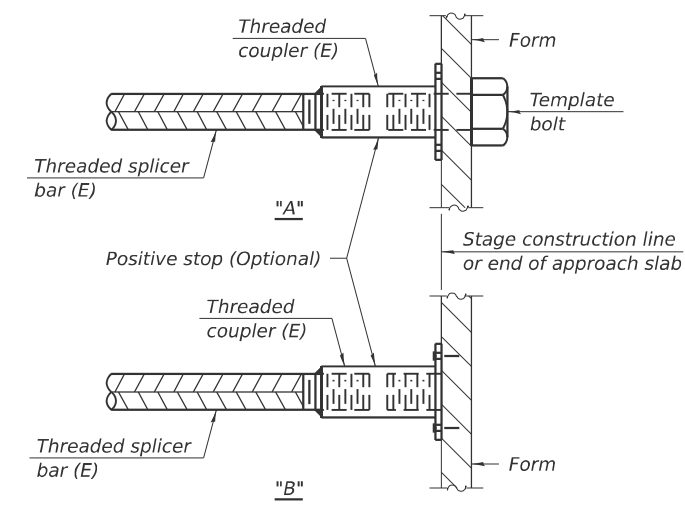

INSTALLATION AND SETTING METHODS
 "A" : Set bar splicer assembly by means of a template bolt.
 "B" : Set bar splicer assembly by nailing to wood forms or cementing to steel forms.
 (E) : Indicates epoxy coating.

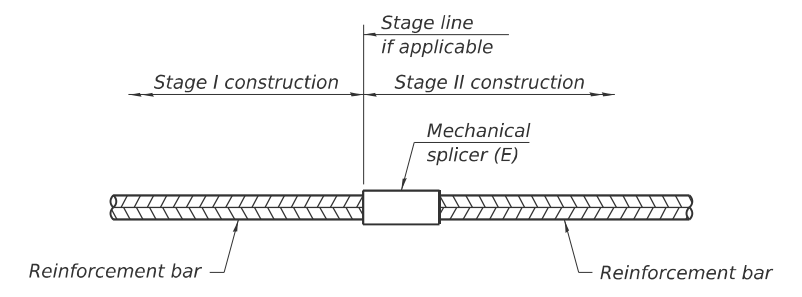

STANDARD MECHANICAL SPLICER

Location	Bar size	No. assemblies required
NA		

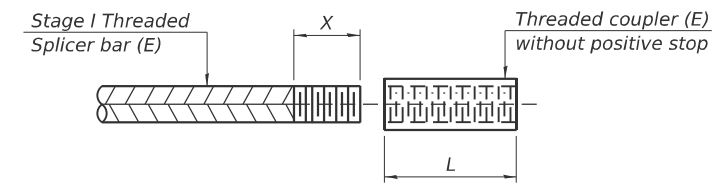

THREADING OF ASSEMBLIES
 The threaded length "X" shall be no more than L/2. The bar should be tightened until 0-1 thread(s) is/are exposed.

Notes:
 Splicer bars shall be deformed with threaded ends and have a minimum 60 ksi yield strength.
 All reinforcement shall be lapped and tied to the splicer bars.
 Bar splicer assemblies shall be epoxy coated according to the requirements for reinforcement bars. See Section 508 of the Standard Specifications.
 See approved list of bar splicer assemblies and mechanical splicers for alternatives.

MODEL: Sheet
 FILE NAME: Y:\DOT11445-01_74D08\74D08 DESIGN\CADD\SP SN 058-0068-0069\Common sheets\0580068-D774D08-27-BarSplice.dgn

BSD-1

4-4-2025



USER NAME = nhc	DESIGNED - ELH 07/25	REVISED -
ESCA PROJECT NO. = 1445.01	CHECKED - RDP 07/25	REVISED -
PLOT SCALE = 0.2" / in.	DRAWN - NHC 07/25	REVISED -
PLOT DATE = 1/20/2026	CHECKED - ELH 07/25	REVISED -

STATE OF ILLINOIS
 DEPARTMENT OF TRANSPORTATION

BAR SPLICER ASSEMBLY AND MECHANICAL SPLICER DETAILS
 SN 058-0068 (WB) & SN 058-0069 (EB)

SHEET 27 OF 33 SHEETS

F.A.I. RTE.	SECTION	COUNTY	TOTAL SHEETS	SHEET NO.
72	D7 BRIDGE REPAIRS 2026-3	MACON	108	66
CONTRACT NO. 74D08				
ILLINOIS FED. AID PROJECT				

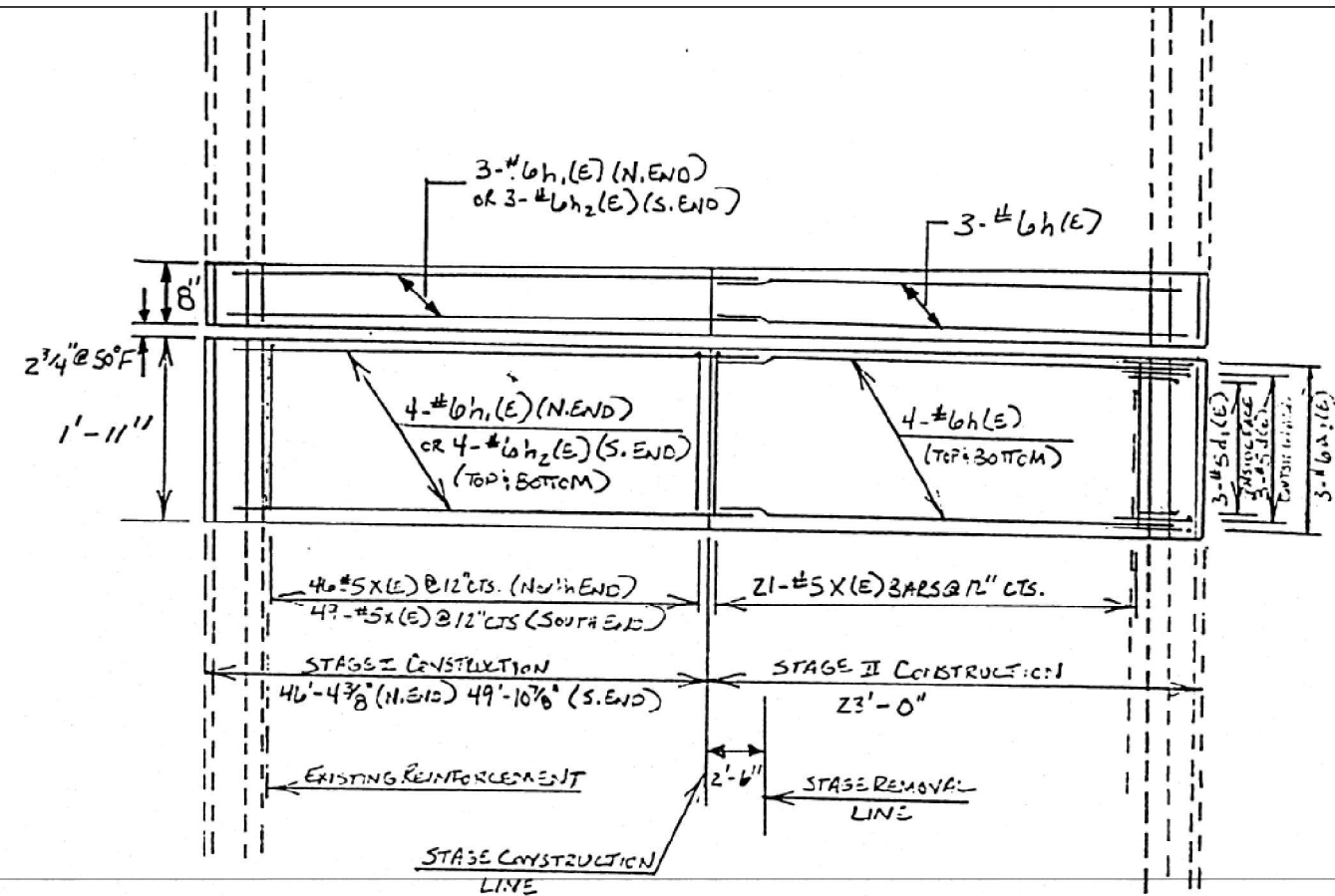

PLAN VIEW
(SHOWING REPLACEMENT)

BILL OF MATERIAL

BAR	NO.	SIZE	LENGTH	SHAPE
h1(E)	22	#6	22'-9"	—
h2(E)	11	#6	48'-1"	—
h3(E)	11	#6	51'-7"	—
d1(E)	12	#5	4'-0"	┌
d2(E)	12	#5	3'-7"	┐
x(E)	137	#5	2'-4"	└
REINFORCEMENT BARS (E)			POUNDS	2906
CONCRETE SUPERSTRUCTURE			CU. YDS.	11.5

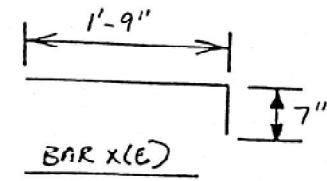
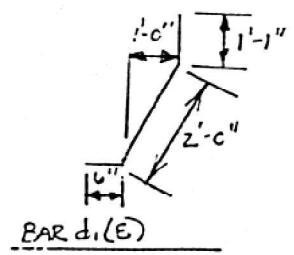
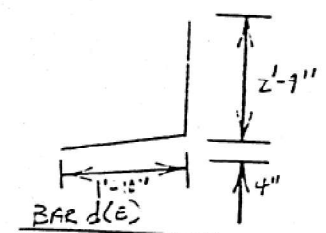
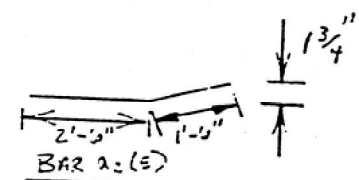

(Sheet 1 of 6)

MODEL: Sheet
FILE NAME: Y:\DOT\1445-01_74D08\74D08 DESIGN\CADD\SP SN 058-0068-0069\Common sheets\0580068-D774D08-28-Ex Plans.dgn



USER NAME = nhc
ESCA PROJECT NO. = 1445.01
PLOT SCALE = 0.2" / in.
PLOT DATE = 1/20/2026

DESIGNED - ELH 07/25
CHECKED - RDP 07/25
DRAWN - NHC 07/25
CHECKED - ELH 07/25

REVISED -
REVISED -
REVISED -
REVISED -

STATE OF ILLINOIS
DEPARTMENT OF TRANSPORTATION

EXISTING BRIDGE PLANS - FOR INFORMATION ONLY
SN 058-0069 (EB)

SHEET 28 OF 33 SHEETS

F.A.I. RTE.	SECTION	COUNTY	TOTAL SHEETS	SHEET NO.
72	D7 BRIDGE REPAIRS 2026-3	MACON	108	67
CONTRACT NO. 74D08				
ILLINOIS FED. AID PROJECT				

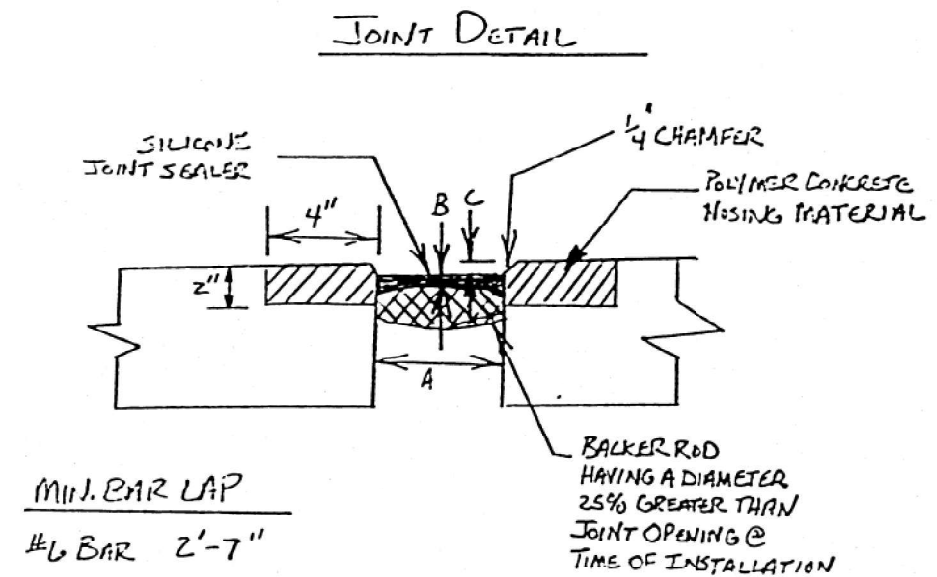
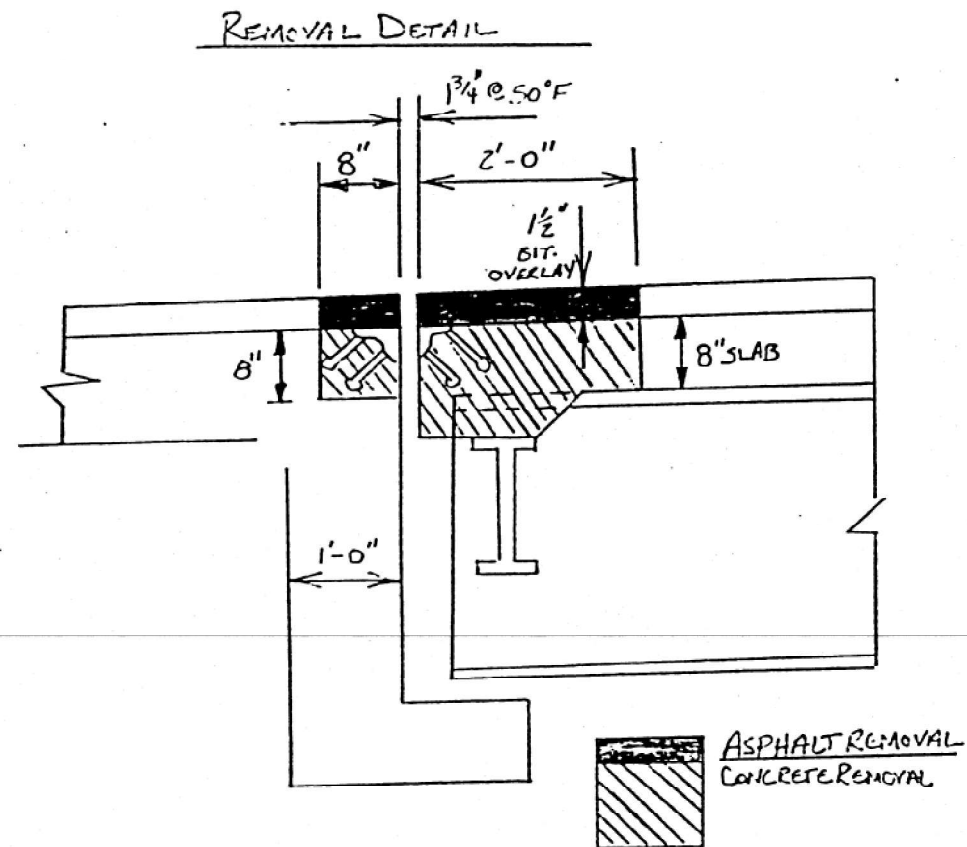

	A	B	C
	JOINT OPENING	SEALANT THICKNESS	SEALANT ACCESS
NORTH ABUTMENT	2 3/4"	5/8"	3/4"
SOUTH ABUTMENT	2 3/4"	5/8"	3/4"

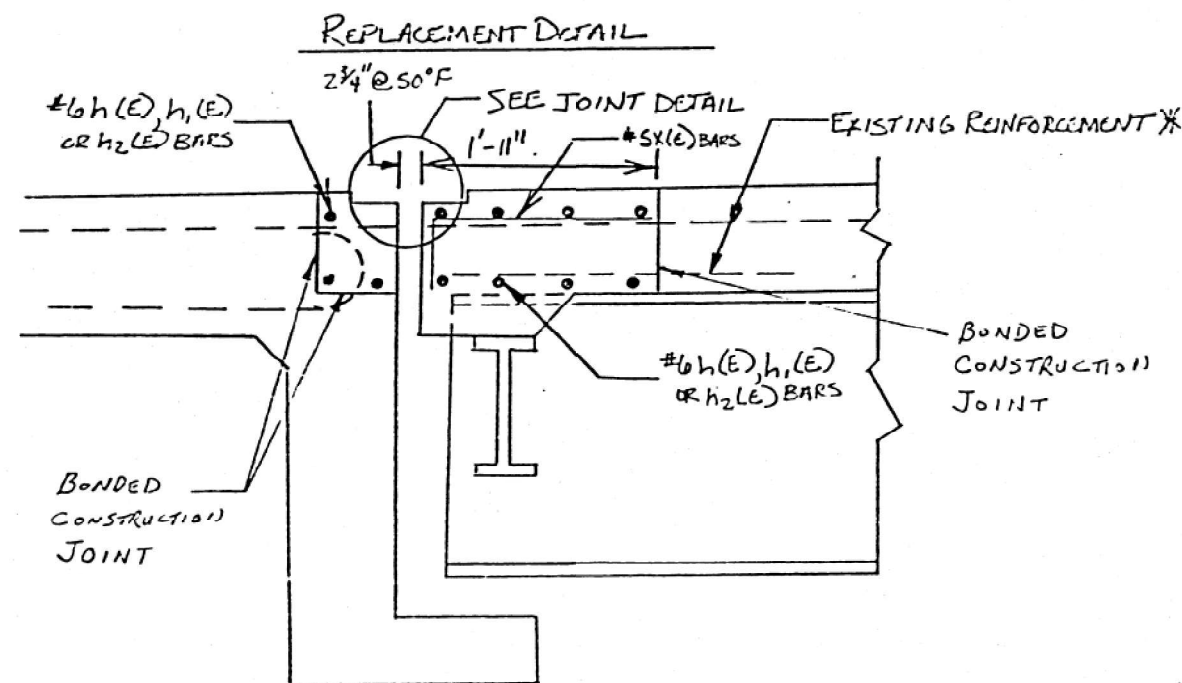

NOTE: NORTH AND SOUTH JOINTS 2 3/4" @ 50' F
ALL MATERIALS, INSTALLATION PROCEDURES AND DIMENSIONS SHALL CONFORM TO THE SPECIAL PROVISIONS AND MANUFACTURER RECOMMENDATIONS.

* EXISTING REINFORCEMENT BARS TO BE RE-USED, SHALL BE CLEANED AND STRAIGHTENED PRIOR TO INCORPORATING INTO THE NEW CONCRETE.

(Sheet 2 of 6)

MODEL: Sheet
FILE NAME: Y:\DOT\1445-01_74D08\74D08 DESIGN\CADD\SP SN 058-0068-0069\Common sheets\0580068-0774D08-29-Ex Plans.dgn



USER NAME = nhc	DESIGNED - ELH 07/25	REVISED -
ESCA PROJECT NO. = 1445.01	CHECKED - RDP 07/25	REVISED -
PLOT SCALE = 0.2" / in.	DRAWN - NHC 07/25	REVISED -
PLOT DATE = 1/20/2026	CHECKED - ELH 07/25	REVISED -

STATE OF ILLINOIS
DEPARTMENT OF TRANSPORTATION

EXISTING BRIDGE PLANS - FOR INFORMATION ONLY
SN 058-0069 (EB)

F.A.I. RTE.	SECTION	COUNTY	TOTAL SHEETS	SHEET NO.
72	D7 BRIDGE REPAIRS 2026-3	MACON	108	68
CONTRACT NO. 74D08				
ILLINOIS FED. AID PROJECT				

SHEET 29 OF 33 SHEETS

ROUTE NO	SECTION	COUNTY	TOTAL SHEETS	SHEET NO
FAI-72	58-62 WB & EB	MACON	69	33
FED. ROAD DIST. NO.		ILLINOIS	PROJECT	

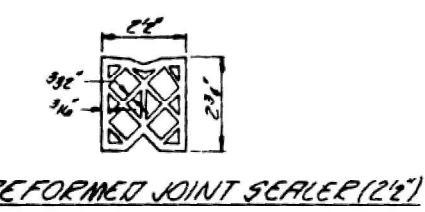
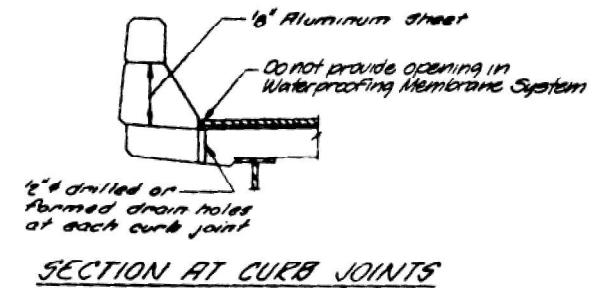
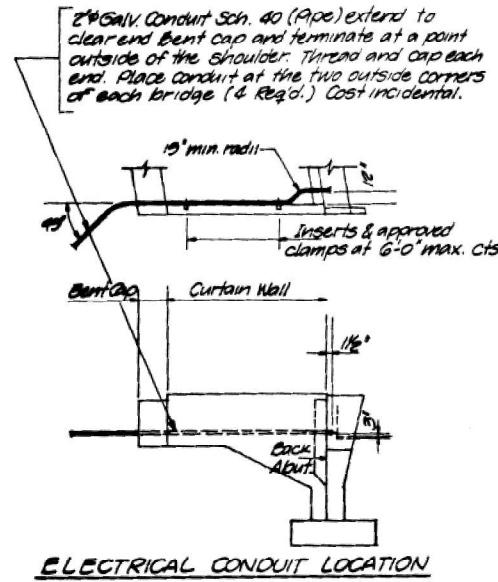

Location	*	**	***
Abut. #1 E.B.	69'-4 1/2'	69'-4 1/2'	70
Abut. #2 E.B.	65'-10 1/8'	65'-10 1/8'	66
Abut. #1 W.B.	55'-1 1/8'	55'-1 1/8'	55
Abut. #2 W.B.	55'-1 1/8'	55'-1 1/8'	55

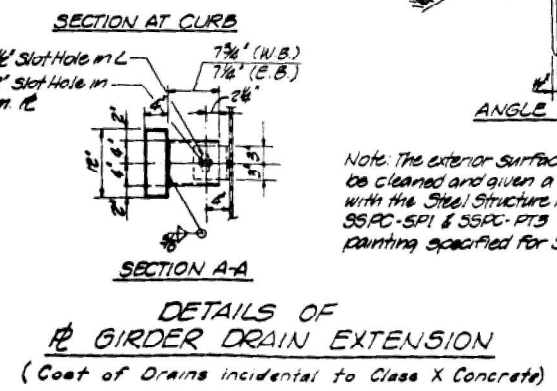
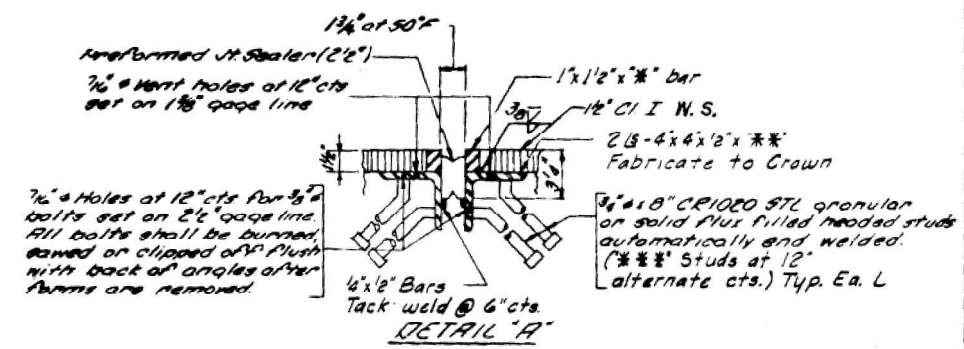
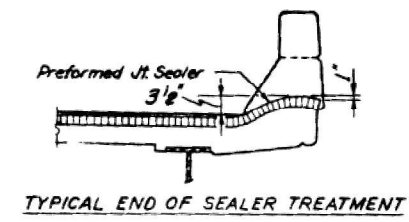
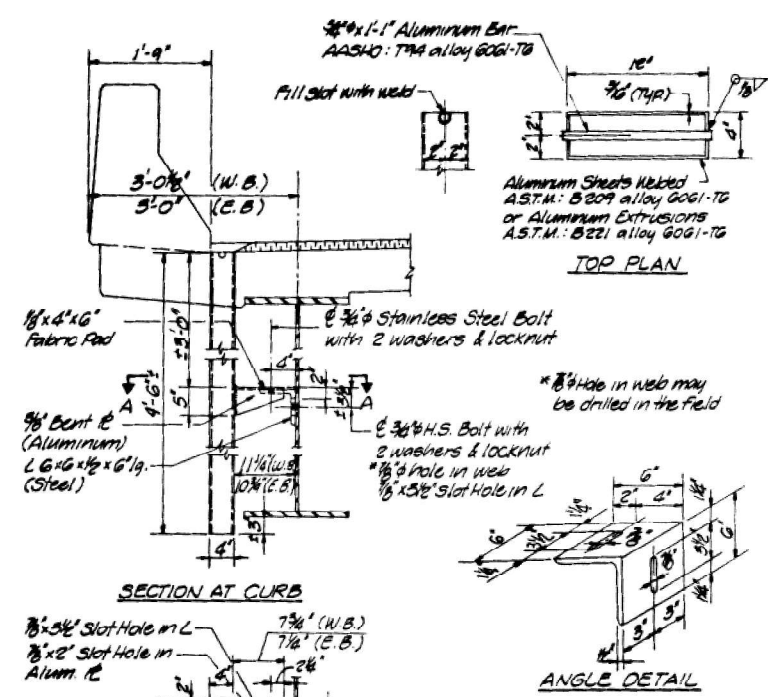

Note: The exterior surfaces of the aluminum drains shall be cleaned and given a washcoat pretreatment in accordance with the Steel Structure Painting Council's Specification SSPC-SP1 & SSPC-PT3 followed by the basic lead chromate painting specified for Structural Steel.

Note: For Waterproofing Membrane System see special provisions

REVISIONS		DETAILS	
No.	DATE	INITIALS	
1			
2			
3			
4			
5			
6			
7			
8			
9			
10			

STATE OF ILLINOIS
DEPT. OF TRANSPORTATION
DIVISION OF HIGHWAYS
F.A.I. 72 OVER US 30
F.A.I. 72 SEC. 58-62 4B-4 PROJ.
STA 508+89.58 & 305+13.04 MACON CO.

HOMER L. CHASTAIN & ASSOCIATES
CONSULTING ENGINEERS
DECATUR, ILLINOIS

DRAWN BY DATE: *LN* 9-74
CHECKED BY DATE: *GS* 2-75
PROJECT NO: 2429-4
SHEET NO: 12

(Sheet 3 of 6)

MODEL: Sheet
FILE NAME: Y:\IDOT\1445-01_74D08\74D08 DESIGN\CADD\SP SN 058-0068-0069\Common sheets\0580068-0069-00-ExPlans.dgn



USER NAME = nhc
ESCA PROJECT NO. = 1445.01
PLOT SCALE = 0.2" = 1' / in.
PLOT DATE = 1/20/2026

DESIGNED -	ELH	07/25	REVISED -
CHECKED -	RDP	07/25	REVISED -
DRAWN -	NHC	07/25	REVISED -
CHECKED -	ELH	07/25	REVISED -

ROUTE NO.	SECTION	COUNTY	TOTAL SHEETS	SHEET NO.
FAI-72	58-624B-1	MACON	69	39

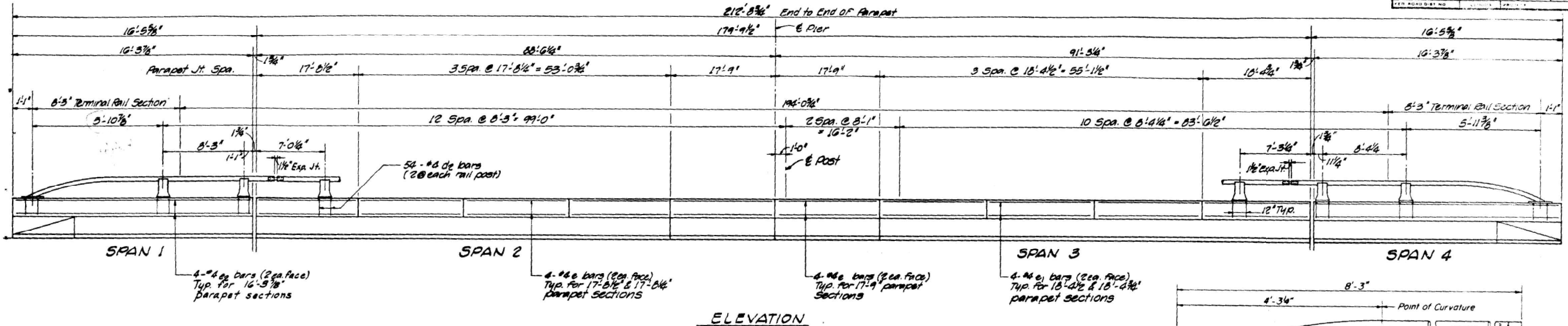

ELEVATION

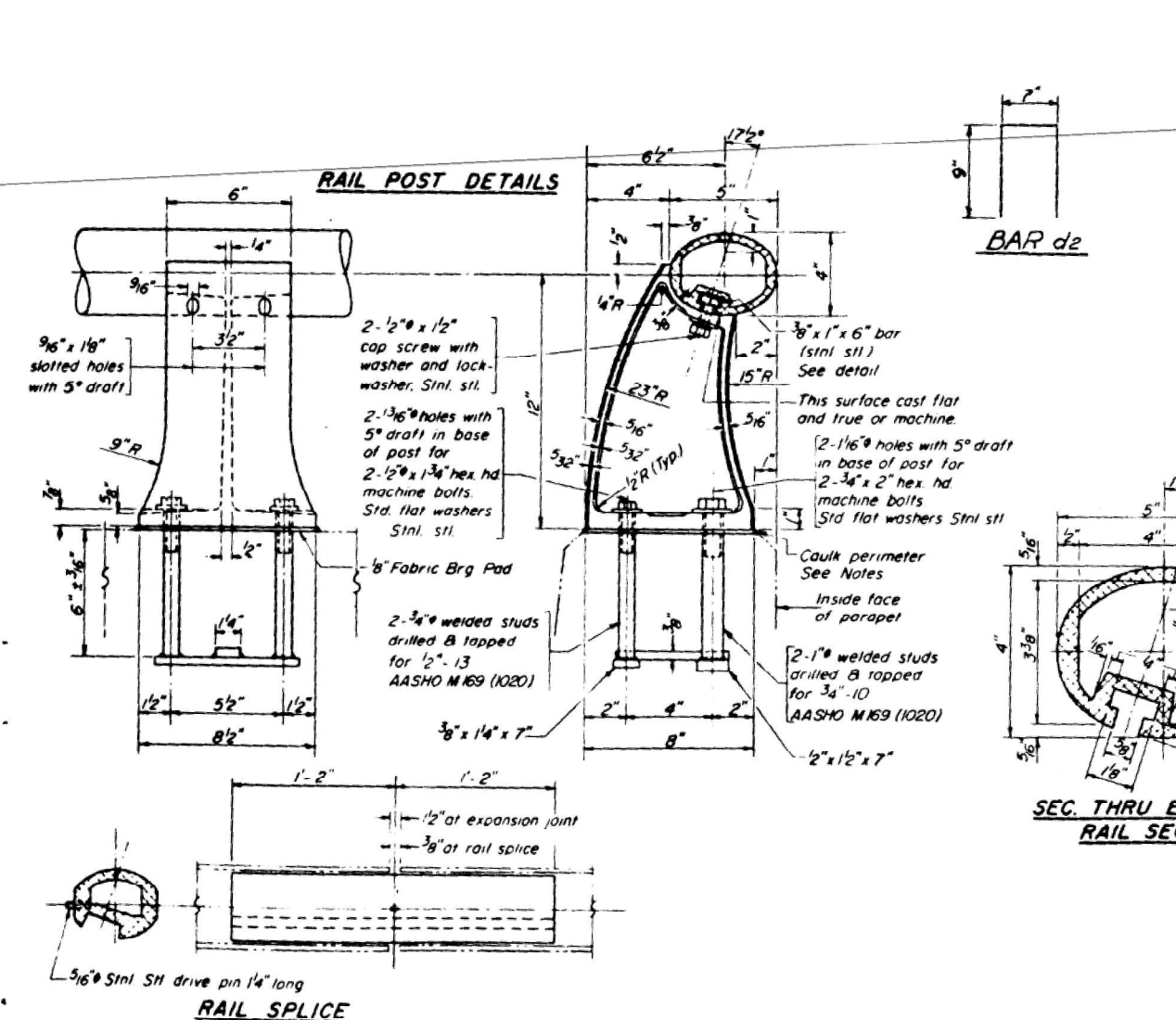

Two component non-staining gray sealing compound with polysulfide liquid polymers - gun grade with primer.

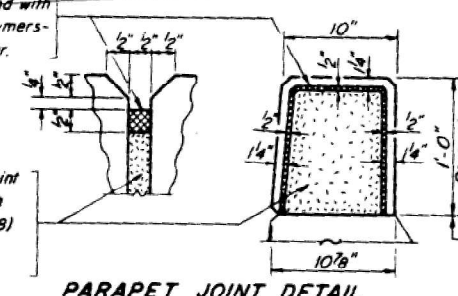

PARAPET JOINT DETAIL

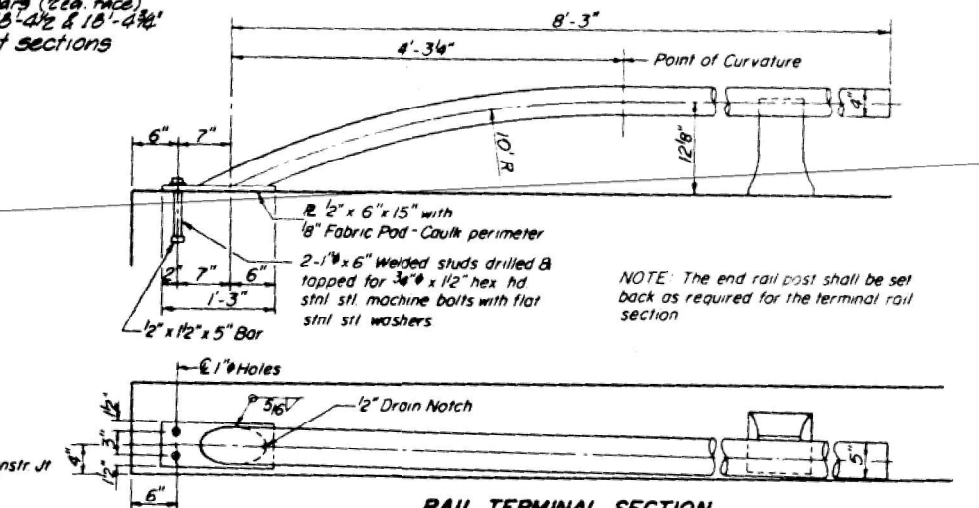

RAIL TERMINAL SECTION

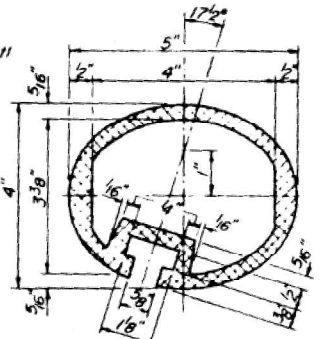

SEC. THRU ELLIPTICAL RAIL SECTION

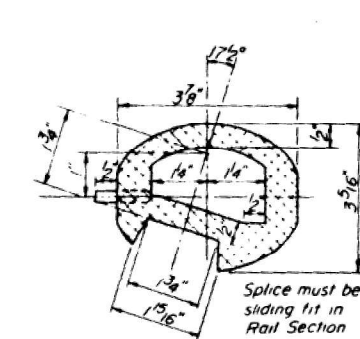

SEC. THRU SPLICE

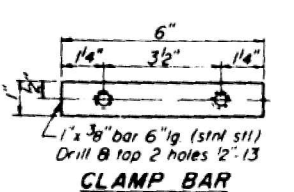

CLAMP BAR

NOTES:
 All Aluminum Alloy Extruded Rail shall be supplied in modular lengths of 30 feet, except at the end of bridge or over open joints in bridge deck where the rail shall be attached to a minimum of 2 posts. If the rail is on a horizontal curve of 2300 foot radius or less, the modular lengths may be reduced but shall be attached to a minimum of 2 posts.
 All joints in rail shall be spliced per detail.
 Provide 1 - 6" and 2 - 16" Aluminum Shims for 25% of the Posts. Rail element shall be parallel to Grade - high spots shall be ground and low spots shimmed.
 Seal perimeter of base of post to parapet with two component non-staining gray sealing compound with polysulfide liquid polymers, gun grade with primer. Fabric Bearing Pad shall have same dimensions as base of post.
 Aluminum alloy rail shall conform to ASTM B221 alloy 6061-T6 or 6351-T5 with min yield 35 ksi, min tensile 38 ksi, and elongation of 10% in 2 inches.
 Stainless steel machine bolts or cap screws shall be in accordance with Article 710.37(a) of the Standard Specifications except Grade 88 or 89M may be furnished.

**PARAPETS & RAILS
BILL OF MATERIAL**

Bar	No.	Size	Length	Shape	
CE	108	#2	2'-0"	□	
E	48	#3	17'-0"	—	
E ₁	32	#2	18'-0"	—	
E ₂	16	#2	16'-0"	—	
Reinforcement Bars				Lbs	1270
Class X Concrete				Cu Yds	13.7
Aluminum Railing				Lin Ft	421

ALUMINUM RAILING - W.B. LANES

REVISIONS	STATE OF ILLINOIS DEPT. OF TRANSPORTATION DIVISION OF HIGHWAYS FAI-72 OVER U.S. 36 SEC. 58-G2-H3-4 PROJ. STA 503+89.55 & 505+13.04 MACON CO.	DATE JUL 5-78 GSH 2-75 PROJECT NO. 246A-4 SHEET NO. 39
1		
2		
3		
4		
5		
6		
7		
8		
9		
10		

(Sheet 4 of 6)

STATE OF ILLINOIS
DEPARTMENT OF TRANSPORTATION

EXISTING BRIDGE PLANS - FOR INFORMATION ONLY
SN 058-0068 (WB) & SN 058-0069 (EB)

F.A.I. RTE.	SECTION	COUNTY	TOTAL SHEETS	SHEET NO.
72	D7 BRIDGE REPAIRS 2026-3	MACON	108	70

SHEET 31 OF 33 SHEETS

ILLINOIS FED. AID PROJECT

MODEL: Sheet
FILE NAME: Y:\DOT\1445-01_74D08\74D08 DESIGN\CADD\SP SN 058-0068-0069\Common sheets\0580068-D774D08-c31-ExPlans.dgn
1/20/2026 10:00:55 AM



USER NAME = nhc
ESCA PROJECT NO. = 1445.01
PLOT SCALE = 0.2" / in.
PLOT DATE = 1/20/2026

DESIGNED - ELH 07/25
CHECKED - RDP 07/25
DRAWN - NHC 07/25
CHECKED - ELH 07/25

REVISED -
REVISED -
REVISED -
REVISED -

ROUTE NO.	SECTION	COUNTY	TOTAL SHEETS	SHEET NO.
FAI-72	58-62-484	MACON	69	37
FID. ROAD DIST. NO.	ILLINOIS PROJECT			

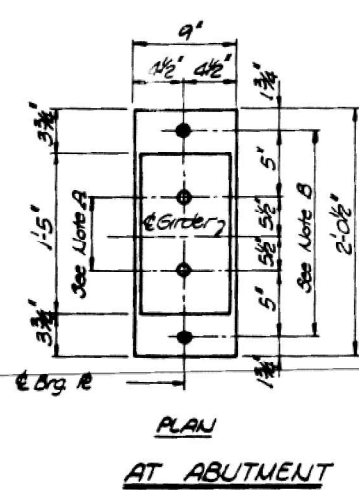
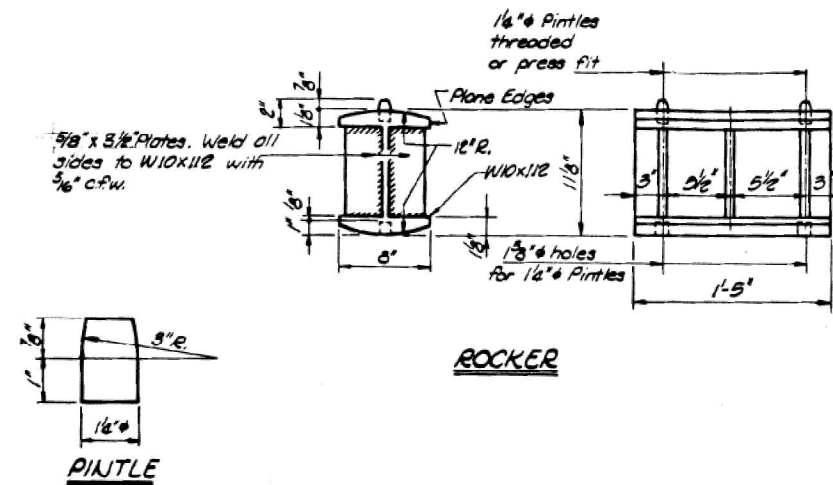
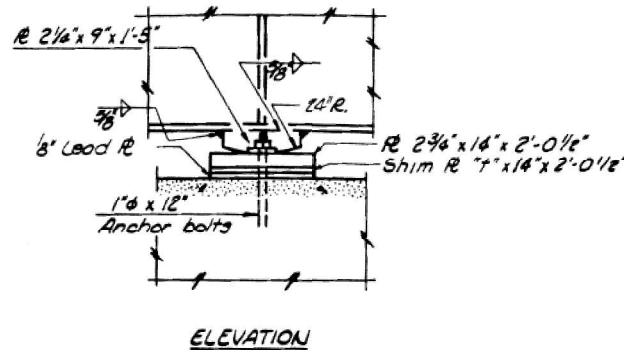
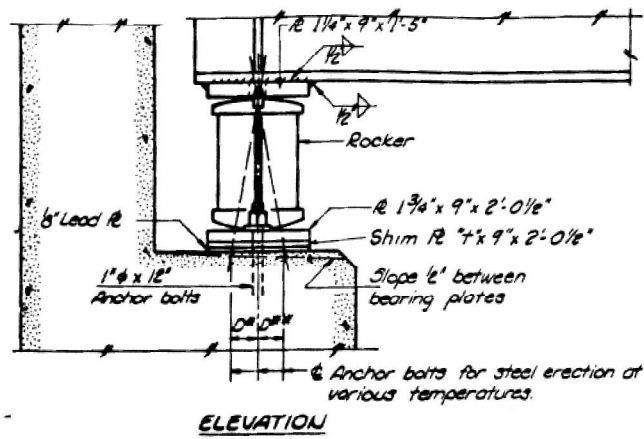

NOTE A
1 3/8" holes - 1" deep in top R for pintles. Thread or press fit pintles into bottom R.

NOTE B
1/2" holes for 1" anchor bolts. 2 1/2" x 2 1/2" x 3/16" R washers under nut.

NOTE C
1 3/8" holes 1" deep in top R only for 1 1/2" pintles.

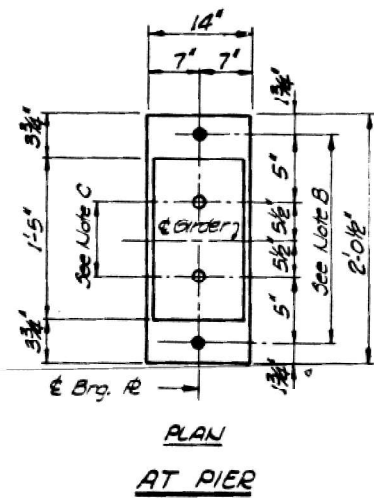

TABLE OF "T" DIMENSIONS

Location	W. Bnd Lanes								E. Bnd Lanes									
	G-1	G-2	G-3	G-4	G-5	G-6	G-7	G-8	G-9	G-10	G-11	G-12	G-13	G-14	G-15	G-16	G-17	G-18
Abut. #1	0"	0"	0"	0"	1 1/16"	0"	0"	0"	0"	0"	0"	1/2"	0"	0"	0"	0"	0"	0"
Pier	0"	0"	0"	0"	1 1/16"	0"	0"	0"	0"	0"	0"	1/2"	0"	0"	0"	0"	0"	0"
Abut. #2	0"	0"	0"	0"	1 1/16"	0"	0"	0"	0"	0"	0"	1/2"	0"	0"	0"	0"	0"	0"

NOTES ON SETTING OF ANCHOR BOLTS AT EXPANSION BEARINGS

- a) D^* (Side of brg. away from fixed brg.)
 $D^* = 1/8"$ per each 100' of expansion for every 15° below the normal temperature of 50° F.
- D^{**} (Side of brg. toward fixed brg.)
 $D^{**} = 1/8"$ per each 100' of expansion for every 15° above the normal temperature of 50° F.
- b) After beams have been erected and dimensions D^* or D^{**} determined, holes shall be drilled and anchor bolts shall be grouted in place. All fixed anchor bolts may be built into the masonry.

MOMENT TABLE - Composite 2 Span (Composite in Positive Moment Areas Only)

	C.G. 30 2	Pier
I_g (in ⁴)	13,842	34,828
I_c (in ⁴)	39,084.0	
I_g (in ⁴)	890	1,565
I_c (in ⁴)	1,158.7	
Q (in)	.997	.997
M_R (k)	475	1297
F_a (k)	6.8	9.9
F_b (k)	3.99	3.99
M_a (k)	236	391
M_b (k)	742	629
M_{imp} (k)	175	147
TOTAL (k)	1153	1167
$F_a + F_b$ (k)	11.9	9.0
F_a TOTAL (k)	18.7	18.9
V_R (k)		57.6

REACTION TABLE INTERIOR GIRDER REACTION TABLE

	N. ABUT.	PIER
R_R (k)	44.5	162.2
R_L (k)	42.4	65.5
$Imp.$ (k)	9.9	15.3
R TOTAL (k)	96.8	243.0

I_g and I_g are the moment of inertia and section modulus of the steel section.
 I_c and I_c are the moment of inertia and section modulus of the composite section used in computing I_g .
 V_R is the maximum \pm impact shear range.
Above data is for Westbound Structure.
Eastbound Structure data slightly less.

BEARING SEAT ADJUSTMENT

Bearing seat surfaces shall be constructed or adjusted to the designated elevations within a tolerance of $\pm 1/8"$. Adjustment shall be made either by grinding the surface or by shimming the bearing. Two 1/2" adjusting shims, of the dimensions of the bottom bearing plate, shall be provided for each bearing in addition to all other plates or shims.

BEARING DETAILS W.B. & E.B. LANES

REVISIONS NO. DATE INITIAL 1 2 3 4 5 6 7 8 9 10	STATE OF ILLINOIS DEPT. OF TRANSPORTATION DIVISION OF HIGHWAYS FAI-72 OVER U.S. 36 FAI-72 SEC. 58-02 HB-4 PROJ. STA 508+8950 & 305+300 MACON CO. HOMER L. CHASTAIN & ASSOCIATES CONSULTING ENGINEERS DECATUR, ILLINOIS	DRAWN BY DATE JEN 7-72 CHECKED BY DATE GSH 2-73 BOOK NUMBER PROJECT NO. 2629-4 SHEET NO. 37
---	---	---

(Sheet 6 of 6)



USER NAME = nhc
ESCA PROJECT NO. = 1445.01
PLOT SCALE = 0.2" = 1'
PLOT DATE = 1/20/2026

DESIGNED - ELH 07/25
CHECKED - RDP 07/25
DRAWN - NHC 07/25
CHECKED - ELH 07/25

REVISED -
REVISED -
REVISED -
REVISED -

STATE OF ILLINOIS
DEPARTMENT OF TRANSPORTATION

EXISTING BRIDGE PLANS - FOR INFORMATION ONLY
SN 058-0068 (WB) & SN 058-0069 (EB)

SHEET 33 OF 33 SHEETS

F.A.I. RTE.	SECTION	COUNTY	TOTAL SHEETS	SHEET NO.
72	D7 BRIDGE REPAIRS 2026-3	MACON	108	72
ILLINOIS FED. AID PROJECT			CONTRACT NO. 74D08	

EXISTING STRUCTURE:

The existing four-span structures were constructed in 1976 as F.A.I. 72 Section 58-62HVB at Station 534+69.66. SN 058-0070 carries I-72 Westbound over Grand Avenue and Norfolk Southern Railway. SN 058-0071 carries I-72 Eastbound over Grand Avenue and Norfolk Southern Railway. In 2006, deck patching was performed and the bituminous wearing surfaces were replaced with microsilica concrete overlays. After that, the expansion joints were replaced at SN 058-0070. The end spans are reinforced concrete slabs, and the main spans are steel welded plate girders. The concrete vaulted abutments and pile bents are supported on concrete piles, and the piers are also supported on concrete piles. Both structures are 211'-0" back-to-back of bent caps, are tapered, and are not skewed. SN 058-0070 is tapered from 51'-10 1/2" to 47'-8 1/8" out-to-out. SN 058-0071 is tapered from 49'-1 3/8" to 44'-11" out-to-out.

The proposed project consists of bridge deck repairs, new concrete overlays, new bearings at the abutments, substructure repairs, and slope wall repairs. Traffic on I-72 is to be maintained utilizing stage construction. Grand Avenue is to be closed during construction. Norfolk Southern Railway traffic is to be maintained during construction.

SCOPE OF WORK

1. Replace bearings at abutments.
2. Replace expansion joints at abutments with Preformed Joint Strip Seal.
3. Perform Bridge Deck Scarification 2 1/4".
4. Perform Deck Slab Repair.
5. Replace existing deck drains with 6" diameter Floor Drains.
6. Construct new 2 1/2" concrete overlays.
7. Perform Diamond Grinding (Bridge Section).
8. Perform Bridge Deck Grooving (Longitudinal).
9. Apply Protective Coat.
10. Construct parapet and substructure repairs.
11. Raise crashwall elevation at piers.
12. Repair South Slope Wall.
13. Replace North Slope Wall.

STRUCTURE INDEX OF SHEETS

General Plan & Elevation	Sheet No. 1 of 36
General Data	Sheet No. 2 of 36
Stage Construction	Sheet No. 3-4 of 36
Temporary Concrete Barrier	Sheet No. 5 of 36
Bridge Deck Patching	Sheet No. 6-7 of 36
Expansion Joint Replacement Details	Sheet No. 8-13 of 36
Deck Drain Details	Sheet No. 14 of 36
Preformed Joint Strip Seal	Sheet No. 15 of 36
Bearing Details	Sheet No. 16-17 of 36
Parapet Repairs	Sheet No. 18-21 of 36
Abutment Repairs	Sheet No. 22-23 of 36
Pier Repairs	Sheet No. 24-26 of 36
North Slope Wall	Sheet No. 27 of 36
South Slope Wall Repairs	Sheet No. 28 of 36
Bar Splicer Assembly and Mechanical Splicer Details	Sheet No. 29 of 36
Existing Bridge Plans	Sheet No. 30-36 of 36

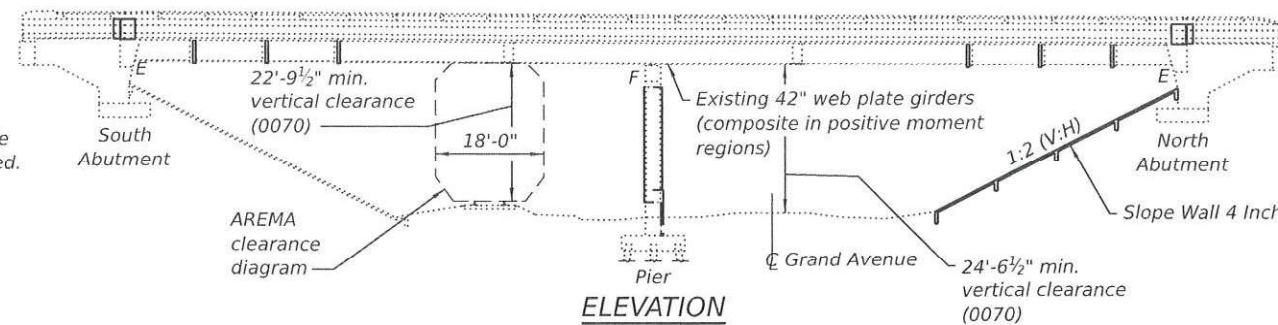

DESIGN SPECIFICATIONS (new const.)

2002 AASHTO Standard Specifications for Highway Bridges, 17th Edition

LOADING HS20-44 & ALTERNATE (new const.)

No allowance for future wearing surface

DESIGN STRESSES

FIELD UNITS
EXISTING CONSTRUCTION
 f_c = 1,400 psi (substructure, curbs, parapets, & approach slabs)
 f_c = 1,200 psi (superstructure slab)
 f_s = 20,000 psi (reinforcement)
NEW CONSTRUCTION
 f_c = 4,000 psi (concrete)
 f_y = 60,000 psi (reinforcement)
 f_y = 36,000 psi (structural steel)

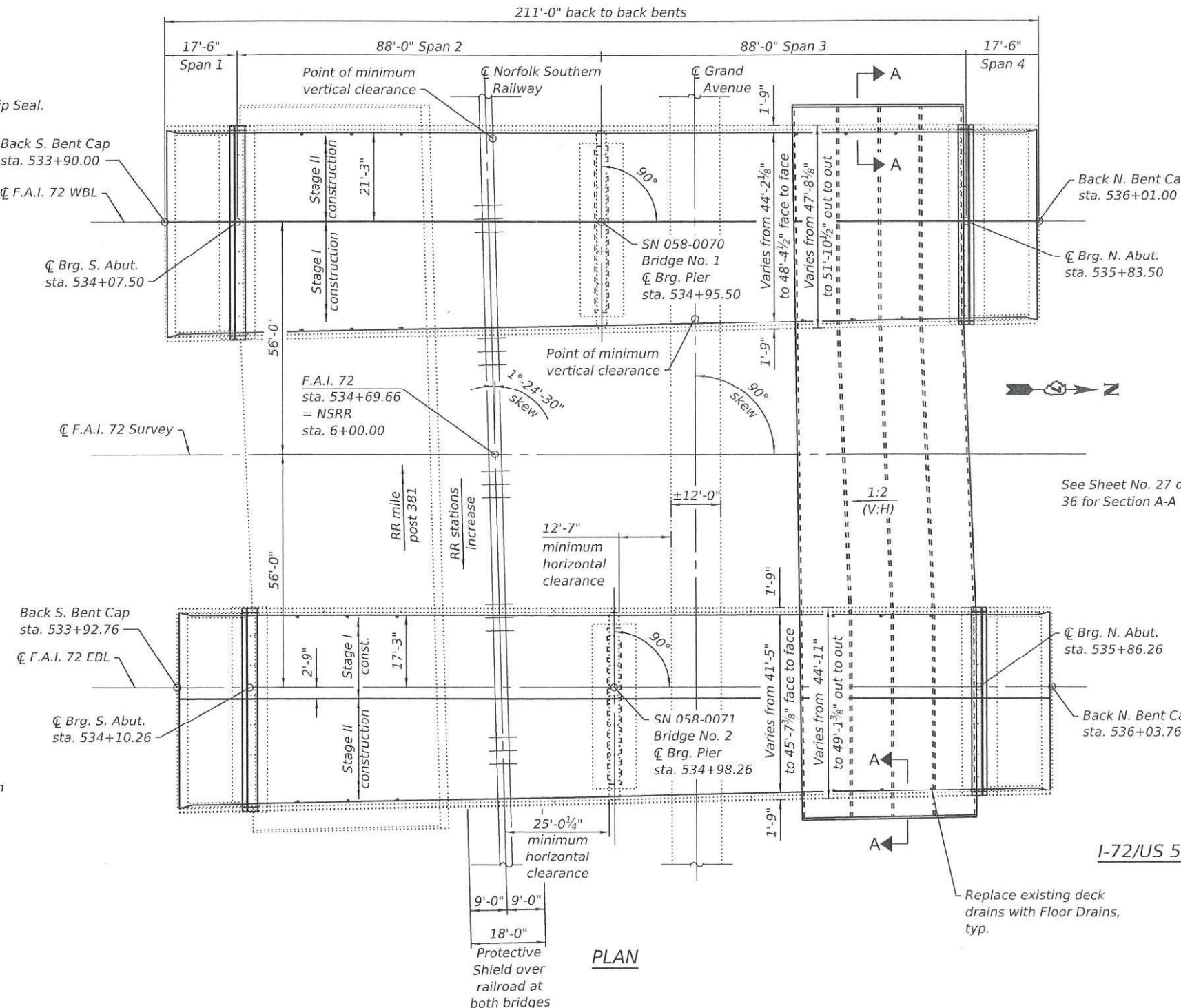
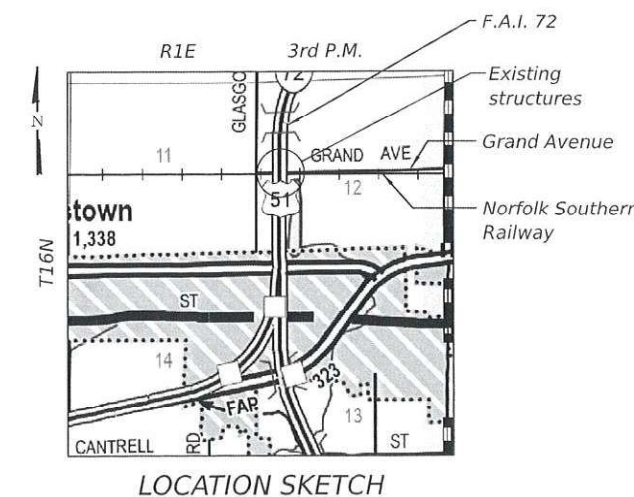

See Sheet No. 27 of 36 for Section A-A



EXPIRES 11-30-26

SIGNATURE

01-22-26
DATE

GENERAL PLAN & ELEVATION
I-72/US 51 OVER GRAND AVE. AND NORFOLK SOUTHERN RR
F.A.I. ROUTE 72
SECTION D7 BRIDGE REPAIRS 2026-3
MACON COUNTY
STATION 534+69.66
STRUCTURE NO. 058-0070/0071

MODEL: Sheet FILE NAME: Y:\DOT\1445-01_74D08\74D08 DESIGN\CADD\SP SN 058-0070-0071\COMMON Sheets\0680070-D774D08-01-GPE.dgn



USER NAME = nhc	DESIGNED - ELH 08/25	REVISED -
ESCA PROJECT NO. = 1445.01	CHECKED - RDP 08/25	REVISED -
PLOT SCALE = 0.2" / in.	DRAWN - NHC 01/26	REVISED -
PLOT DATE = 1/21/2026	CHECKED - ELH 01/26	REVISED -

STATE OF ILLINOIS
DEPARTMENT OF TRANSPORTATION

F.A.I. RTE.	SECTION	COUNTY	TOTAL SHEETS	SHEET NO.
72	D7 BRIDGE REPAIRS 2026-3	MACON	108	73
CONTRACT NO. 74D00				
ILLINOIS FED. AID PROJECT				

GENERAL NOTES

1. Reinforcement bars designated (E) shall be epoxy coated.
2. Plan dimensions and details relative to the existing structures have been taken from existing plans and are subject to nominal construction variations. The Contractor shall field verify existing dimensions and details affecting new construction and make necessary approved adjustments prior to construction or ordering of materials. Such variations shall not be cause for additional compensation for a change in scope of work; however, the Contractor will be paid for the quantity actually furnished at the unit price bid for the work.
3. Existing reinforcement bars extending into the removal area shall be cleaned, straightened, and incorporated into the new construction. Cost included in Concrete Removal. Any reinforcement bars that are damaged during concrete removal shall be replaced with an approved bar splicer or anchorage system at the Contractor's expense.
4. Areas of deck repairs shown are estimated. The Engineer shall show actual locations and size of deck repairs on As-Built Plans.
5. The existing structural steel coating contains lead. The existing bearings contain lead plates. The Contractor shall take appropriate precautions to deal with the presence of lead on this project.
6. No field welding is permitted except as specified in the contract documents.
7. Prior to pouring the new concrete deck, all heavy or loose rust, loose mill scale, and other loose detrimental foreign material shall be removed from the surfaces in contact with concrete (SSPC-SP3 standards). Tightly adhered paint may remain unless otherwise noted. Removal shall be accomplished by methods that will not damage the steel and the cost will be included in Concrete Removal.
8. The cost of floor drains to be removed is included in Deck Slab Repair.
9. All new structural steel extensions, bearing assemblies, and shim plates shall be hot dip galvanized. See special provision for "Hot Dip Galvanizing for Structural Steel."
10. Joint openings shall be adjusted according to Article 520.04 of the Std. Specs. when the deck is poured at an ambient temperature other than 50° F.
11. Removal and reinstallation of the handrail sections and support posts at both abutments will be necessary for construction of the expansion joints. The existing handrail sections and support posts shall be reused. New bolts, shim plates, and post support anchor assemblies, as detailed in the existing plans, are to be provided and installed for the replacement of the handrail sections. This work and all materials shall be included in the contract unit price for Concrete Superstructure.
12. Full depth deck slab repairs performed in the exterior bays of the bridge deck (between the parapet walls and the first interior beams) shall be limited to individual lengths no greater than 10'. In these portions of the deck, repair areas longer than 10' shall be divided into segments not greater than 10' in length, and the segments shall be poured in alternating sequence. Subsequent segments repaired in sequence shall not be removed until 72 hours have elapsed from the end of the previous, adjacent pour, and the adjacent pour shall have attained a minimum modulus of rupture of 650 psi.
13. Protective Coat shall be applied to areas of Concrete Superstructure consisting of the front faces and tops of the parapets and the expansion joint concrete. Protective Coat shall also be applied to the tops of the new concrete overlays and new portions of concrete slope walls.
14. Up to ¼ inch is to be ground off the proposed concrete overlays.
15. The Contractor shall take all measures necessary to ensure that no debris from the repairs is allowed to reach the railroad track or ballast. Cost is included with the appropriate pay item.
16. The work shall not change the quantity and/or character of flow in the Railway's ditches and/or drainage structures. The Railway's ditches shall be maintained at the same slope and grade as existing conditions.
17. The quantities and locations of Structural Repair of Concrete are approximated. Actual quantities and locations are to be determined in the field by the Engineer. This work is intended to repair only areas of severe deterioration. Some minor deteriorated areas may be left unrepaired. Do not disturb the bearings during the repair of adjacent concrete areas.
18. Cleaning and painting of the existing structural steel shall be as specified in the special provision for "Cleaning and Painting Existing Steel Structures." All beams and other structural steel within 5'-0" from the beam end (measured along the beam) shall be cleaned per Near White Blast Cleaning - SSPC-SP10.
19. All structural steel shall conform to AASHTO Classification M-270 Gr. 36, unless otherwise noted.

20. The designated areas cleaned per Near White Blast Cleaning shall be painted according to the requirements of the Organic Zinc-Rich Primer/Epoxy Intermediate Coat/Urethane Topcoat paint system. The color of the final finish coat for all interior steel surfaces shall be Gray, Munsell No. 5B 7/1. The color of the final finish coat for the exterior surfaces and bottom flange of the fascia beams shall be Interstate Green, Munsell No. 7.5G 4/8. Only the 5'-0" of steel near the joint will be painted. The remaining portions of the steel will not be coated in this contract.
21. SSPC QP1 and SSPC QP2 Certifications are required for this Contract.
22. A minimum of one air monitor will be required to monitor abrasive blasting operations at this site. See special provision for "Containment and Disposal of Lead Paint Cleaning Residues."
23. The Contractor shall take all measures necessary to ensure that the RWIS weather station conduit attached to the bottom of the bridge shall be undisturbed. Contact: Doug Rudolphi, D7 Maintenance Field Engineer, cell: 217-299-4636. The existing sensor shall be removed from the bridge deck by the Contractor during deck patching operations. The sensor shall be salvaged and turned over to the D7 Maintenance Field Engineer.
24. Structure number 058-0070 is referred to as Bridge No. 1. Structure number 058-0071 is referred to as Bridge No. 2.

TOTAL BILL OF MATERIAL

ITEM	UNIT	SN 058-0070	SN 058-0071	TOTAL
Removal and Disposal of Unsuitable Material	Cu. Yd.	20	35	55
Subbase Granular Material, Type B	Ton	100	155	255
Concrete Removal	Cu. Yd.	13.8	12.7	26.5
Slope Wall Removal	Sq. Yd.	448	448	896
Protective Shield	Sq. Yd.	101	96	197
Floor Drains	Each	12	12	24
Concrete Structures	Cu. Yd.	21.7	21.6	43.3
Concrete Superstructure	Cu. Yd.	13.4	12.4	25.8
Protective Coat	Sq. Yd.	1,532	1,550	3,082
Furnishing and Erecting Structural Steel	Pound	2,925	2,956	5,881
Reinforcement Bars, Epoxy Coated	Pound	3,970	3,810	7,780
Bar Splicers	Each	20	20	40
Slope Wall 4 Inch	Sq. Yd.	444	444	888
Preformed Joint Strip Seal	Foot	97	91	188
Elastomeric Bearing Assembly, Type I	Each	14	14	28
Anchor Bolts, 1"	Each	24	24	48
Bridge Deck Grooving (Longitudinal)	Sq. Yd.	742	678	1,420
Slope Wall Repair	Sq. Yd.	0	80	80
Slope Wall Slurry Pumping	Cu. Yd.	37	13	50
Jack and Remove Existing Bearings	Each	14	14	28
Containment and Disposal of Lead Paint Cleaning Residues No.1	L Sum	1	0	1
Containment and Disposal of Lead Paint Cleaning Residues No.2	L Sum	0	1	1
Cleaning and Painting Steel Bridge No. 1	L Sum	1	0	1
Cleaning and Painting Steel Bridge No. 2	L Sum	0	1	1
Bridge Deck Fly Ash or GGBF Slag Concrete Overlay, 2½"	Sq. Yd.	1,043	983	2,026
Bridge Deck Scarification 2¼"	Sq. Yd.	1,043	983	2,026
Structural Repair of Concrete (Depth Equal to or Less Than 5 Inches)	Sq. Ft.	197	214	411
Deck Slab Repair (Full Depth, Type I)	Sq. Yd.	14	19	33
Deck Slab Repair (Full Depth, Type II)	Sq. Yd.	89	62	151
Diamond Grinding (Bridge Section)	Sq. Yd.	987	923	1,910

MODEL: Sheet
FILE NAME: Y:\DOT11445-01_74D08\74D08 DESIGN\CADD\SP SN 058-0070-0071\COMMON SHEETS\0580070-0071-008-02-GenNotes.dgn



USER NAME = nhc	DESIGNED - ELH 01/26	REVISED -
ESCA PROJECT NO. = 1445.01	CHECKED - RDP 01/26	REVISED -
PLOT SCALE = 0:2 " = 1" / in.	DRAWN - NHC 01/26	REVISED -
PLOT DATE = 1/21/2026	CHECKED - ELH 01/26	REVISED -

**STATE OF ILLINOIS
DEPARTMENT OF TRANSPORTATION**

**GENERAL DATA
SN 058-0070 (WB) & SN 058-0071 (EB)**

F.A.I. RTE.	SECTION	COUNTY	TOTAL SHEETS	SHEET NO.
72	D7 BRIDGE REPAIRS 2026-3	MACON	108	74
CONTRACT NO. 74D08				
ILLINOIS		FED. AID PROJECT		

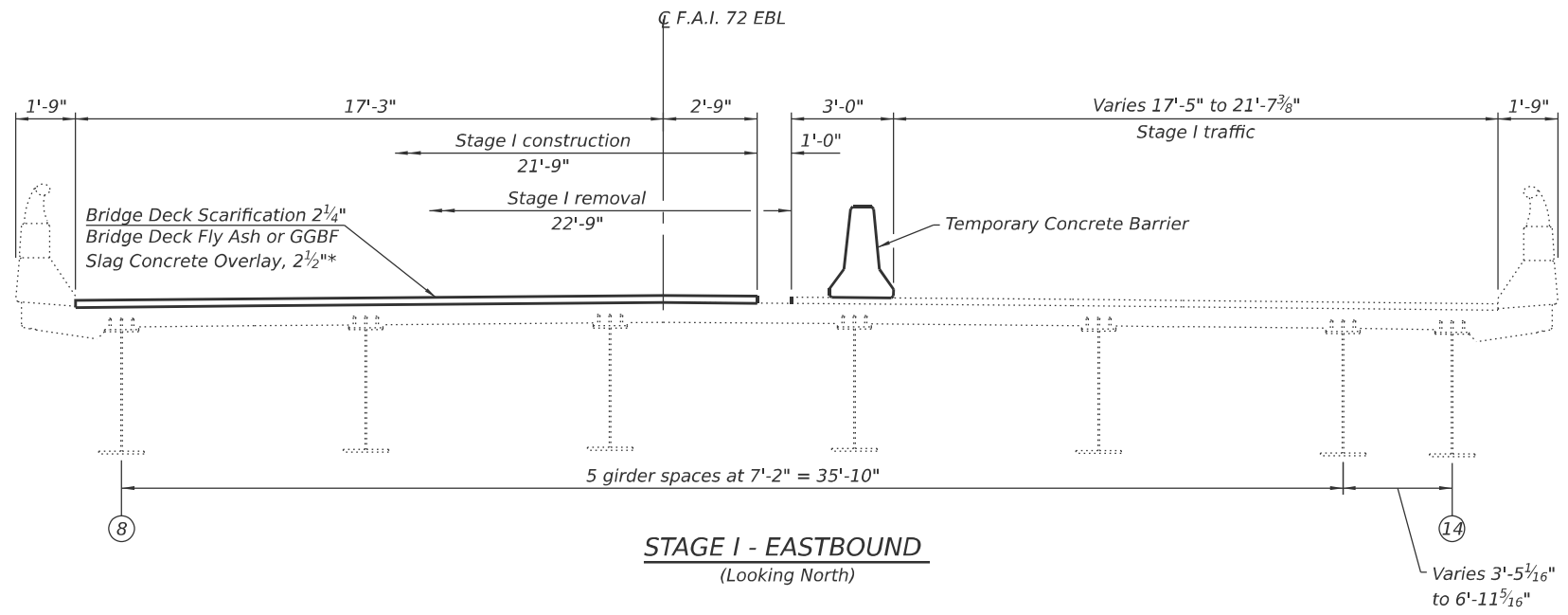

*Prior to 1/4" grinding

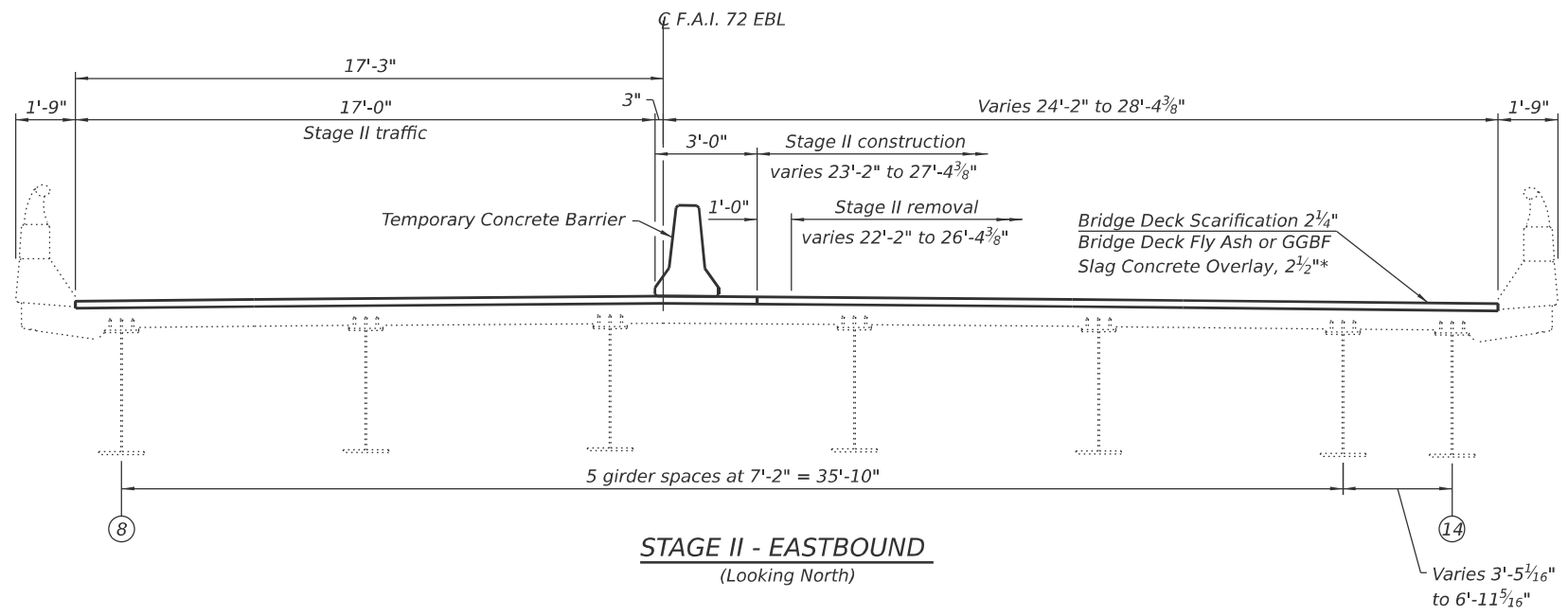

MODEL: Sheet
FILE NAME: Y:\IDOT\1445-01_74D08\74D08 DESIGN\CADD\SP SN 058-0070-04-StageCon(EB).dgn

(Sheet 2 of 2)



USER NAME = nhc	DESIGNED - ELH 01/26	REVISED -
ESCA PROJECT NO. = 1445.01	CHECKED - RDP 01/26	REVISED -
PLOT SCALE = 0.2" / in.	DRAWN - NHC 01/26	REVISED -
PLOT DATE = 1/21/2026	CHECKED - ELH 01/26	REVISED -

**STATE OF ILLINOIS
DEPARTMENT OF TRANSPORTATION**

**STAGE CONSTRUCTION
SN 058-0071 (EB)**

SHEET 4 OF 36 SHEETS

F.A.I. RTE.	SECTION	COUNTY	TOTAL SHEETS	SHEET NO.
72	D7 BRIDGE REPAIRS 2026-3	MACON	108	76
CONTRACT NO. 74D08				
ILLINOIS FED. AID PROJECT				

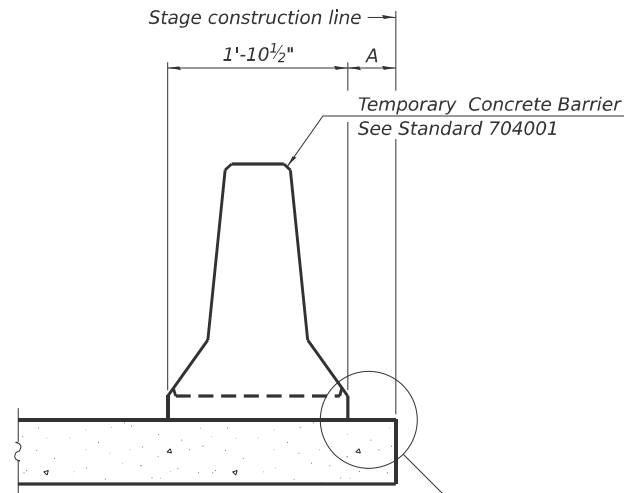

When "A" is 3'-1" or less, the temporary concrete barrier shall be restrained to the new slab according to Detail I, II or III. No restraint is required when "A" is greater than 3'-1".

NEW SLAB OR NEW DECK BEAM

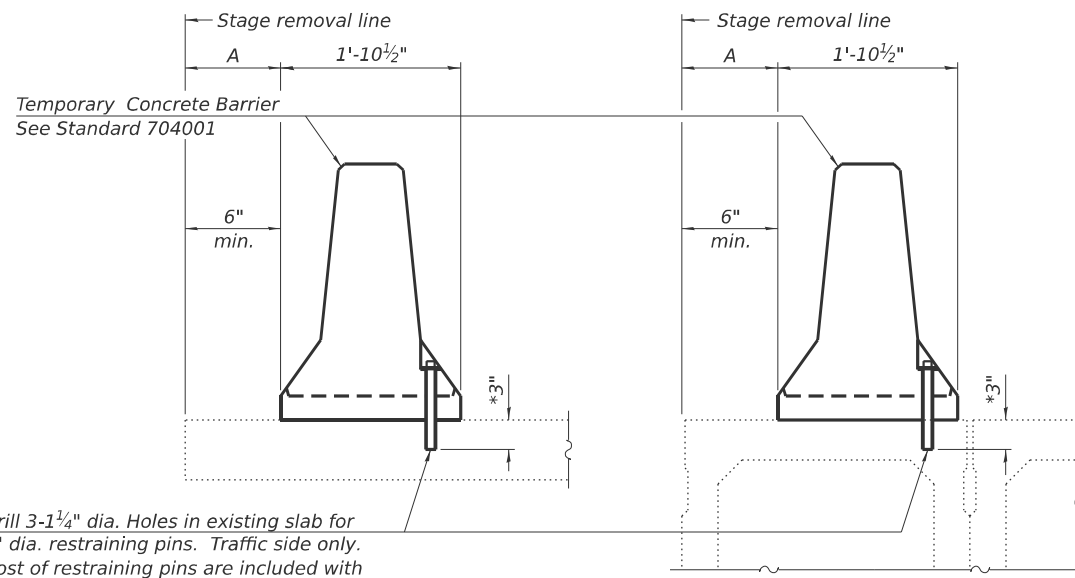

Drill 3-1/4" dia. Holes in existing slab for 1" dia. restraining pins. Traffic side only. Cost of restraining pins are included with Temporary Concrete Barrier. No restraint is required when "A" is greater than 3'-1".

EXISTING SLAB

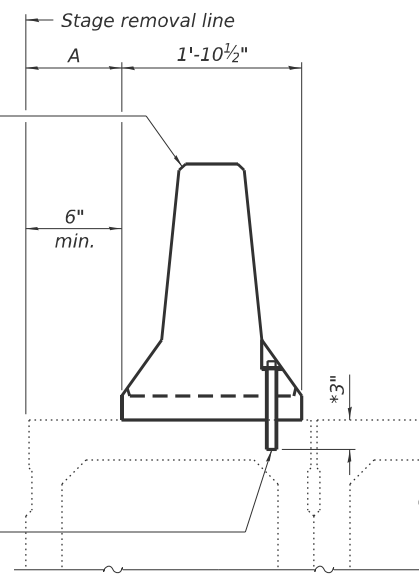

* When hot-mix asphalt wearing surface is present, embedment shall be 3" plus the wearing surface depth.

EXISTING DECK BEAM

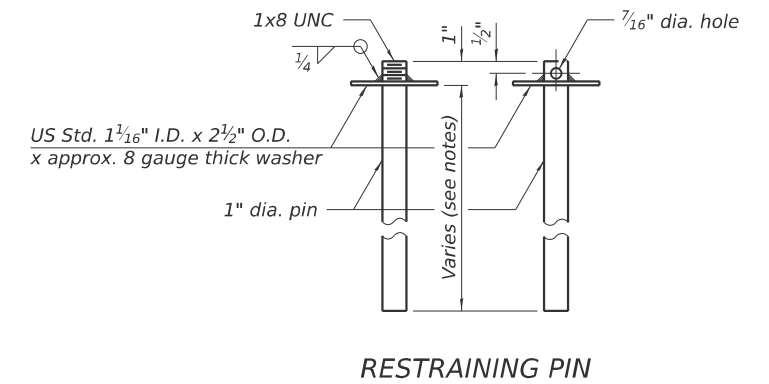

RESTRAINING PIN

SECTIONS THRU SLAB OR DECK BEAM

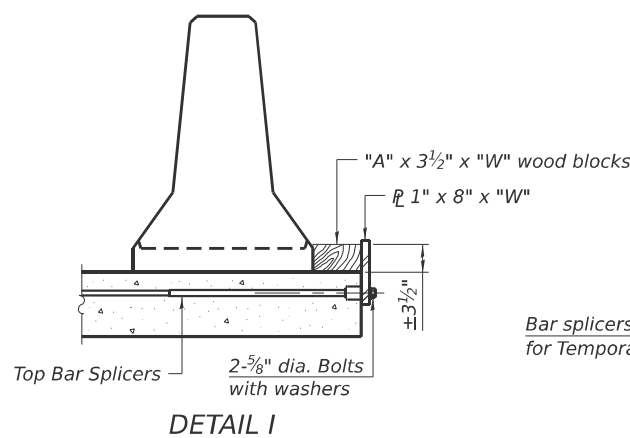

DETAIL I

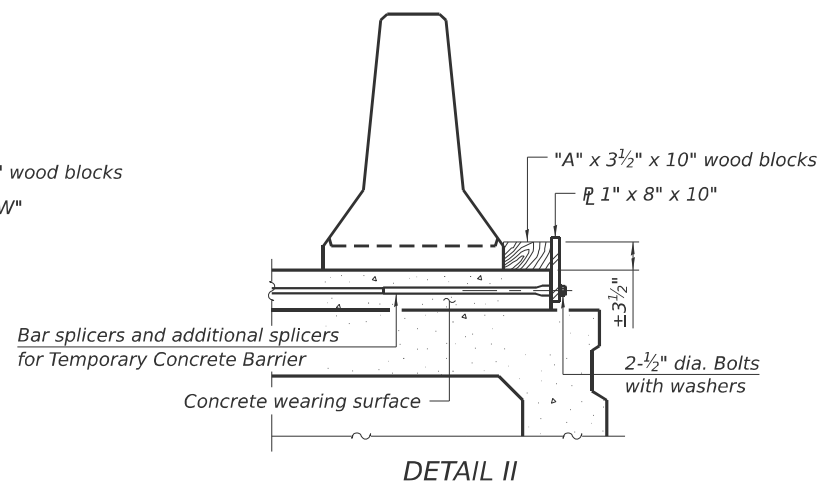

DETAIL II

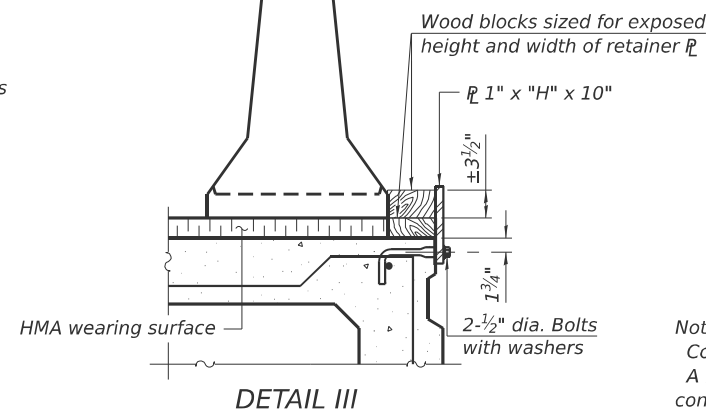

DETAIL III

BAR SPLICER FOR #4 BAR - DETAIL III

Notes:
 Cost of retainer assembly is included with Temporary Concrete Barrier.
 A retainer assembly shall be located at the approximate center of each temporary concrete barrier.
 The retainer plate shall not be removed until the concrete on the adjacent stage is ready to be poured. For Detail III applications the retainer plate shall not be removed until just prior to placing the adjacent beam.
 When the 'A' dimension is less than 1 1/2", the wood block shall be omitted and the barrier shall be placed in direct contact with the steel retainer plate.
 For deck beam applications the minimum required 'A' distance is 6" to accommodate the shear key clamping device.

Detail I - Installation for a new bridge deck or bridge slab.

Detail II - Installation for a new deck beam with an initial concrete wearing surface. Additional bar splicers shall be provided at 6'-0" centers and paired with the bar splicers of the concrete wearing surface reinforcement to accommodate the installation of the retainer assemblies. The cost of the additional bar splicers is included with the concrete wearing surface.

Detail III - Installation for a new deck beam with no initial wearing surface or with an initial hot-mix asphalt (HMA) wearing surface present. The deck beam directly beneath the temporary concrete barrier shall be fabricated with bar splicer inserts in the side of the beam, as detailed, to accommodate the installation of the retainer assemblies. A pair of bar splicers, 6" apart, shall be placed at 6'-0" centers along the length of the beam. The cost of the bar splicers is included with the deck beam.

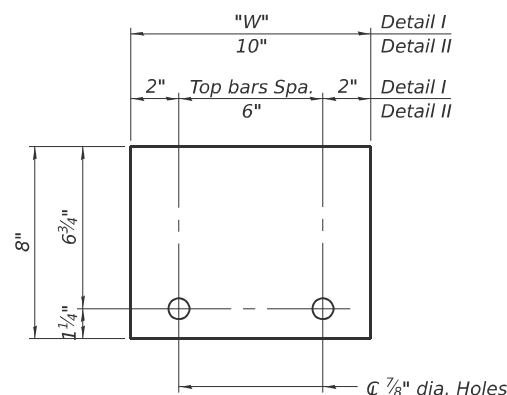

STEEL RETAINER 1" x 8" x "W"
(Detail I and II)

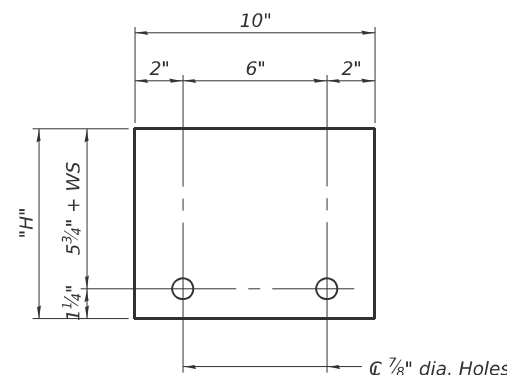

STEEL RETAINER 1" x "H" x 10"
(Detail III)

RAILING CRITERIA

NCHRP 350 Test Level	3
Railing Weight (plf)	440

R-27 5-15-2023

MODEL: Sheet
 FILE NAME: Y:\DOT11445-01_74D08\74D08 DESIGN\CADD\SP SN 058-0070-0071\Common Sheets\0580070-0071-74D08-05-TCB.dgn



USER NAME = nhc
 ESCA PROJECT NO. = 1445.01
 PLOT SCALE = 0.2" = 1' / in.
 PLOT DATE = 1/20/2026

DESIGNED - ELH 07/25
 CHECKED - RDP 07/25
 DRAWN - NHC 07/25
 CHECKED - ELH 07/25

REVISED -
 REVISED -
 REVISED -
 REVISED -

STATE OF ILLINOIS
 DEPARTMENT OF TRANSPORTATION

TEMPORARY CONCRETE BARRIER
 SN 058-0070 (WB) & SN 058-0071 (EB)

SHEET 5 OF 36 SHEETS

F.A.I. RTE.	SECTION	COUNTY	TOTAL SHEETS	SHEET NO.
72	D7 BRIDGE REPAIRS 2026-3	MACON	108	77
CONTRACT NO. 74D08				
ILLINOIS FED. AID PROJECT				

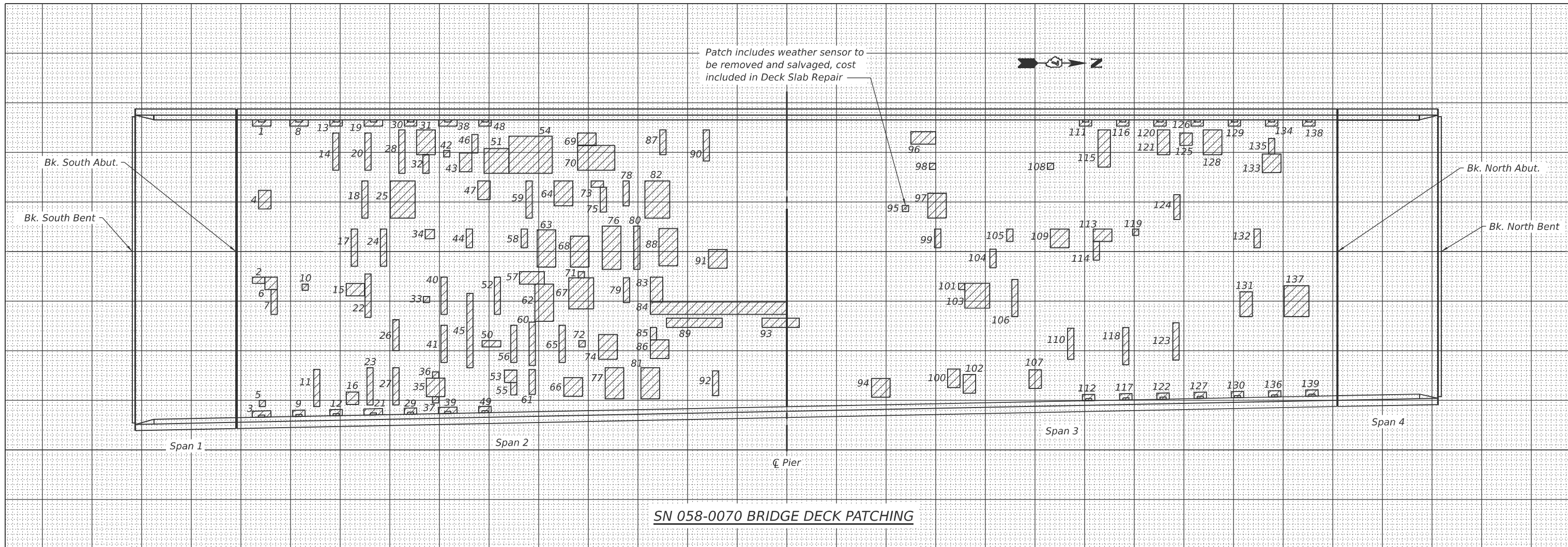

SN 058-0070 BRIDGE DECK PATCHING

PATCH NO.	LENGTH	WIDTH	DECK SLAB REPAIR (FD, TY I) SQ YD	DECK SLAB REPAIR (FD, TY II) SQ YD
1	3	1	0.3	
2	2	1	0.2	
3	3	1	0.3	
4	2	3		0.7
5	1	1	0.1	
6	2	2	0.4	
7	1	4	0.4	
8	3	1	0.3	
9	2	1	0.2	
10	1	1	0.1	
11	1	6		0.7
12	2	1	0.2	
13	2	1	0.2	
14	1	6		0.7
15	3	2		0.7
16	2	2	0.4	
17	1	6		0.7
18	1	6		0.7
19	3	1	0.3	
20	1	6		0.7
21	3	1	0.3	
22	1	7		0.8
23	1	6		0.7
24	1	6		0.7
25	4	6		2.7
26	1	5		0.6
27	1	6		0.7
28	1	7		0.8
29	2	1	0.2	

PATCH NO.	LENGTH	WIDTH	DECK SLAB REPAIR (FD, TY I) SQ YD	DECK SLAB REPAIR (FD, TY II) SQ YD
30	2	1	0.2	
31	3	4		1.3
32	1	3		0.3
33	1	1	0.1	
34	1.5	1.5	0.3	
35	3	3		1.0
36	1	1		0.1
37	1	1		0.1
38	3	1	0.3	
39	3	1	0.3	
40	1	6		0.7
41	1	6		0.7
42	1	1	0.1	
43	2	3		0.7
44	1	3	0.3	
45	1	12		1.3
46	1	3	0.3	
47	2	3		0.7
48	2	1	0.2	
49	2	1	0.2	
50	3	1	0.3	
51	4	4		1.8
52	1	6		0.7
53	2	2		0.4
54	7	6		4.7
55	1	2		0.2
56	1	6		0.7
57	4	2		0.9
58	1	3	0.3	

PATCH NO.	LENGTH	WIDTH	DECK SLAB REPAIR (FD, TY I) SQ YD	DECK SLAB REPAIR (FD, TY II) SQ YD
59	1	6		0.7
60	1	7		0.8
61	1	4	0.4	
62	3	6		2.0
63	3	6		2.0
64	3	4		1.3
65	1	6		0.7
66	3	3		1.0
67	4	5		2.2
68	3	5		1.7
69	2	3		0.7
70	6	4		2.7
71	1	1		0.1
72	1	1	0.1	
73	2	1		0.2
74	3	4		1.3
75	1	4		0.4
76	3	7		2.3
77	3	5		1.7
78	1	4	0.4	
79	1	4	0.4	
80	1	7		0.8
81	3	5		1.7
82	4	6		2.7
83	2	4		0.9
84	22	2		4.9
85	1	2		0.2
86	3	3		1.0
87	1	4	0.4	

PATCH NO.	LENGTH	WIDTH	DECK SLAB REPAIR (FD, TY I) SQ YD	DECK SLAB REPAIR (FD, TY II) SQ YD
88	3	6		2.0
89	9	1.5		1.5
90	1	5		0.6
91	3	3		1.0
92	1	4	0.4	
93	6	1.5		1.0
94	3	3		1.0
95	1	1	0.1	
96	4	2		0.9
97	3	4		1.3
98	1	1	0.1	
99	1	3	0.3	
100	2	3		0.7
101	1	1		0.1
102	2	3		0.7
103	4	4		1.8
104	1	3	0.3	
105	1	2	0.2	
106	1	6		0.7
107	2	3		0.7
108	1	1	0.1	
109	3	3		1.0
110	1	5		0.6
111	2	1	0.2	
112	2	1	0.2	
113	3	2		0.7
114	1	3		0.3
115	2	6		1.3
116	2	1	0.2	

PATCH NO.	LENGTH	WIDTH	DECK SLAB REPAIR (FD, TY I) SQ YD	DECK SLAB REPAIR (FD, TY II) SQ YD
117	2	1	0.2	
118	1	6		0.7
119	1	1	0.1	
120	2	1	0.2	
121	2	4		0.9
122	2	1	0.2	
123	1	6		0.7
124	1	4	0.4	
125	2	2	0.4	
126	2	1	0.2	
127	2	1	0.2	
128	3	4		1.3
129	2	1	0.2	
130	2	1	0.2	
131	2	4		0.9
132	1	3	0.3	
133	3	3		1.0
134	2	1	0.2	
135	1	2.5		0.3
136	2	1	0.2	
137	4	5		2.2
138	2	1	0.2	
139	2	1	0.2	
TOTAL ROUNDS TO:			14.0	89.0

THE LOCATIONS AND SIZES SHOWN GRAPHICALLY ABOVE ARE APPROXIMATE. SEE THIS TABLE FOR ACTUAL SIZES.



DATE OF SURVEY: 07-08-25
SURVEY BY: ESCA CONSULTANTS
METHOD OF SURVEY: VISUAL

ESTIMATED PAY QUANTITIES:

DECK SLAB REPAIR (FULL DEPTH, TYPE I)
14.0 SQ YD

DECK SLAB REPAIR (FULL DEPTH, TYPE II)
89.0 SQ YD

MODEL: Sheet
FILE NAME: Y:\IDOT\1445-01_74D08\74D08 DESIGN\CADD\SP SN 058-0070-071\Common Sheets\0580070-071-DeckPatching(WB).dgn



USER NAME = nhc
ESCA PROJECT NO. = 1445.01
PLOT SCALE = 0.2" = 1'
PLOT DATE = 1/20/2026

DESIGNED - ELH 07/25
CHECKED - RDP 07/25
DRAWN - NHC 07/25
CHECKED - ELH 07/25

REVISED -
REVISED -
REVISED -
REVISED -

STATE OF ILLINOIS
DEPARTMENT OF TRANSPORTATION

BRIDGE DECK PATCHING
SN 058-0070 (WB)

SHEET 6 OF 36 SHEETS

F.A.I. RTE.	SECTION	COUNTY	TOTAL SHEETS	SHEET NO.
72	D7 BRIDGE REPAIRS 2026-3	MACON	108	78
CONTRACT NO. 74D08				
ILLINOIS FED. AID PROJECT				

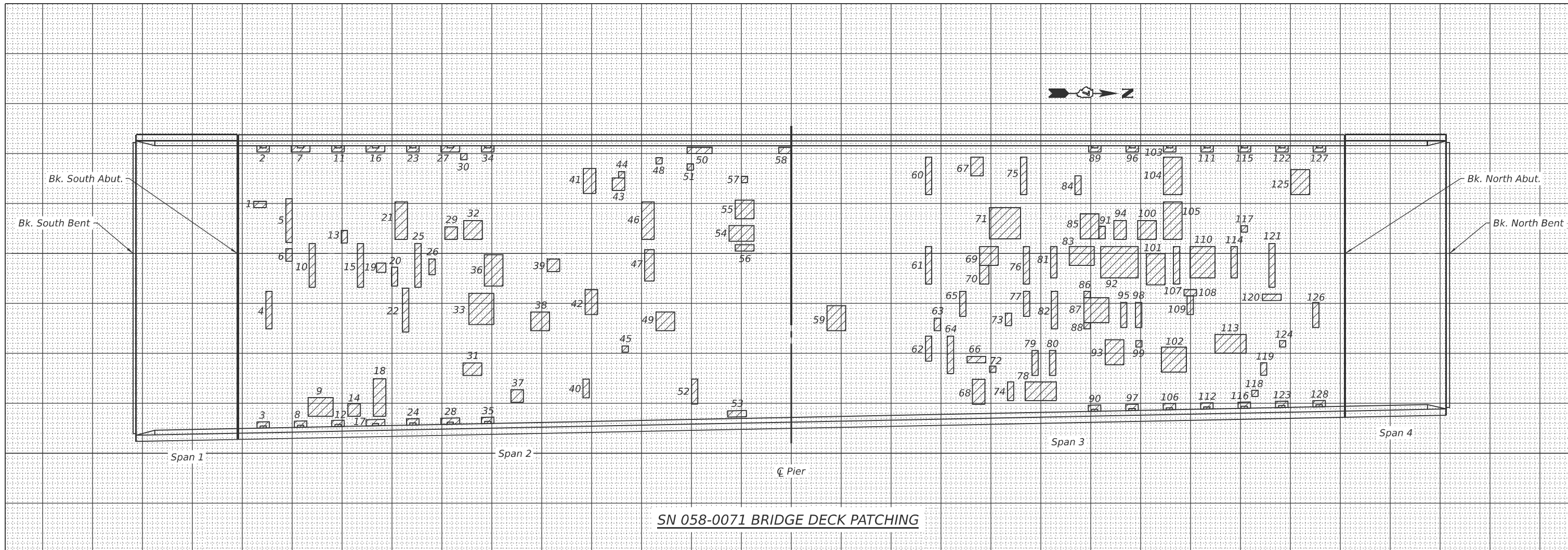

SN 058-0071 BRIDGE DECK PATCHING

PATCH NO.	SIZE (FEET)		DECK SLAB REPAIR (FD, TY I) SQ YD	DECK SLAB REPAIR (FD, TY II) SQ YD
	LENGTH	WIDTH		
1	2	1	0.2	
2	2	1	0.2	
3	2	1	0.2	
4	1	6		0.7
5	1	7		0.8
6	1	2	0.2	
7	3	1	0.3	
8	2	1	0.2	
9	4	3		1.3
10	1	7		0.8
11	2	1	0.2	
12	2	1	0.2	
13	1	2	0.2	
14	2	2	0.4	
15	1	7		0.8
16	3	1	0.3	
17	3	1	0.3	
18	2	6		1.3
19	1.5	1.5	0.3	
20	1	3	0.3	
21	2	6		1.3
22	1	7		0.8
23	2	1	0.2	
24	2	1	0.2	
25	1	7		0.8
26	1	2.5	0.3	
27	3	1	0.3	
28	3	1	0.3	
29	2	2	0.4	

PATCH NO.	SIZE (FEET)		DECK SLAB REPAIR (FD, TY I) SQ YD	DECK SLAB REPAIR (FD, TY II) SQ YD
	LENGTH	WIDTH		
30	1	1	0.1	
31	3	2		0.7
32	3	3		1.0
33	4	5		2.2
34	2	1	0.2	
35	2	1	0.2	
36	3	5		1.7
37	2	2	0.4	
38	3	3		1.0
39	2	2	0.4	
40	1	3	0.3	
41	2	4		0.9
42	2	4		0.9
43	2	2	0.4	
44	1	1	0.1	
45	1	1	0.1	
46	2	6		1.3
47	1.5	5		0.8
48	1	1	0.1	
49	3	3		1.0
50	4	1	0.4	
51	1	1	0.1	
52	1	4	0.4	
53	3	1	0.3	
54	4	2.5		1.1
55	3	3		1.0
56	3	1	0.3	
57	1	1	0.1	
58	2	1	0.2	

PATCH NO.	SIZE (FEET)		DECK SLAB REPAIR (FD, TY I) SQ YD	DECK SLAB REPAIR (FD, TY II) SQ YD
	LENGTH	WIDTH		
59	3	4		1.3
60	1	6		0.7
61	1	6		0.7
62	1	4	0.4	
63	1	2	0.2	
64	1	6		0.7
65	1	4	0.4	
66	3	1	0.3	
67	2	3		0.7
68	2	4		0.9
69	3	3		1.0
70	1.5	3	0.5	
71	5	5		2.8
72	1	1	0.1	
73	1	2	0.2	
74	1	3	0.3	
75	1	6		0.7
76	1	6		0.7
77	1	4	0.4	
78	5	3		1.7
79	1	4	0.4	
80	1	4	0.4	
81	1	5		0.6
82	1	6		0.7
83	4	3		1.3
84	1	3	0.3	
85	3	4		1.3
86	1	1		0.1
87	4	4		1.8

PATCH NO.	SIZE (FEET)		DECK SLAB REPAIR (FD, TY I) SQ YD	DECK SLAB REPAIR (FD, TY II) SQ YD
	LENGTH	WIDTH		
88	1	1		0.1
89	2	1	0.2	
90	2	1	0.2	
91	1	2	0.2	
92	6	5		3.3
93	3	4		1.3
94	2	3		0.7
95	1	4	0.4	
96	2	1	0.2	
97	2	1	0.2	
98	1	4	0.4	
99	1	1	0.1	
100	3	3		1.0
101	3	5		1.7
102	4	4		1.8
103	2	1	0.2	
104	3	6		2.0
105	3	6		2.0
106	2	1	0.2	
107	1	6		0.7
108	2	1		0.2
109	1	3		0.3
110	4	5		2.2
111	2	1	0.2	
112	2	1	0.2	
113	5	3		1.7
114	1	5		0.6
115	2	1	0.2	
116	2	1	0.2	

PATCH NO.	SIZE (FEET)		DECK SLAB REPAIR (FD, TY I) SQ YD	DECK SLAB REPAIR (FD, TY II) SQ YD
	LENGTH	WIDTH		
117	1	1	0.1	
118	1	1	0.1	
119	1	2	0.2	
120	3	1	0.3	
121	1	7		0.8
122	2	1	0.2	
123	2	1	0.2	
124	1	1	0.1	
125	3	4		1.3
126	1	4	0.4	
127	2	1	0.2	
128	2	1	0.2	
TOTAL ROUNDS TO:			19.0	62.0

THE LOCATIONS AND SIZES SHOWN GRAPHICALLY ABOVE ARE APPROXIMATE. SEE THIS TABLE FOR ACTUAL SIZES.



DATE OF SURVEY: 07-08-25
 SURVEY BY: ESCA CONSULTANTS
 METHOD OF SURVEY: VISUAL

ESTIMATED PAY QUANTITIES:

DECK SLAB REPAIR (FULL DEPTH, TYPE I)
 19.0 SQ YD

DECK SLAB REPAIR (FULL DEPTH, TYPE II)
 62.0 SQ YD

STATE OF ILLINOIS
 DEPARTMENT OF TRANSPORTATION

BRIDGE DECK PATCHING
 SN 058-0071 (EB)

SHEET 7 OF 36 SHEETS

F.A.I. RTE.	SECTION	COUNTY	TOTAL SHEETS	SHEET NO.
72	D7 BRIDGE REPAIRS 2026-3	MACON	108	79
CONTRACT NO. 74D08				
ILLINOIS FED. AID PROJECT				

MODEL: Sheet
 FILE NAME: Y:\IDOT\1445-01_74D08\74D08 DESIGN\CADD\SP SN 058-0071\Common Sheets\0580070-D774D08-07-DeckPatching(EB).dgn



USER NAME = nhc
 ESCA PROJECT NO. = 1445.01
 PLOT SCALE = 0.2" = 1' / in.
 PLOT DATE = 1/20/2026

DESIGNED - ELH 07/25
 CHECKED - RDP 07/25
 DRAWN - NHC 07/25
 CHECKED - ELH 07/25

REVISED -
 REVISED -
 REVISED -
 REVISED -

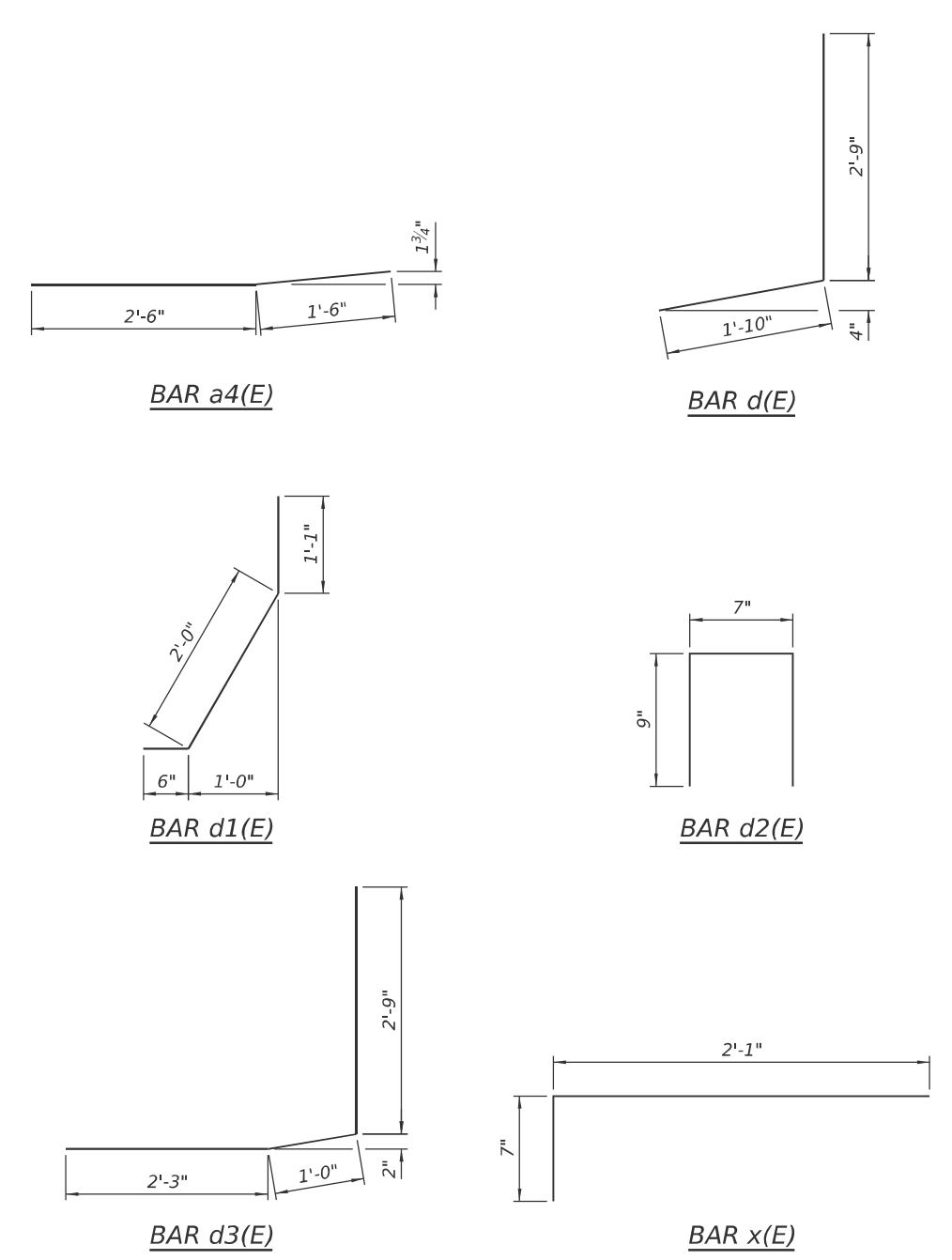
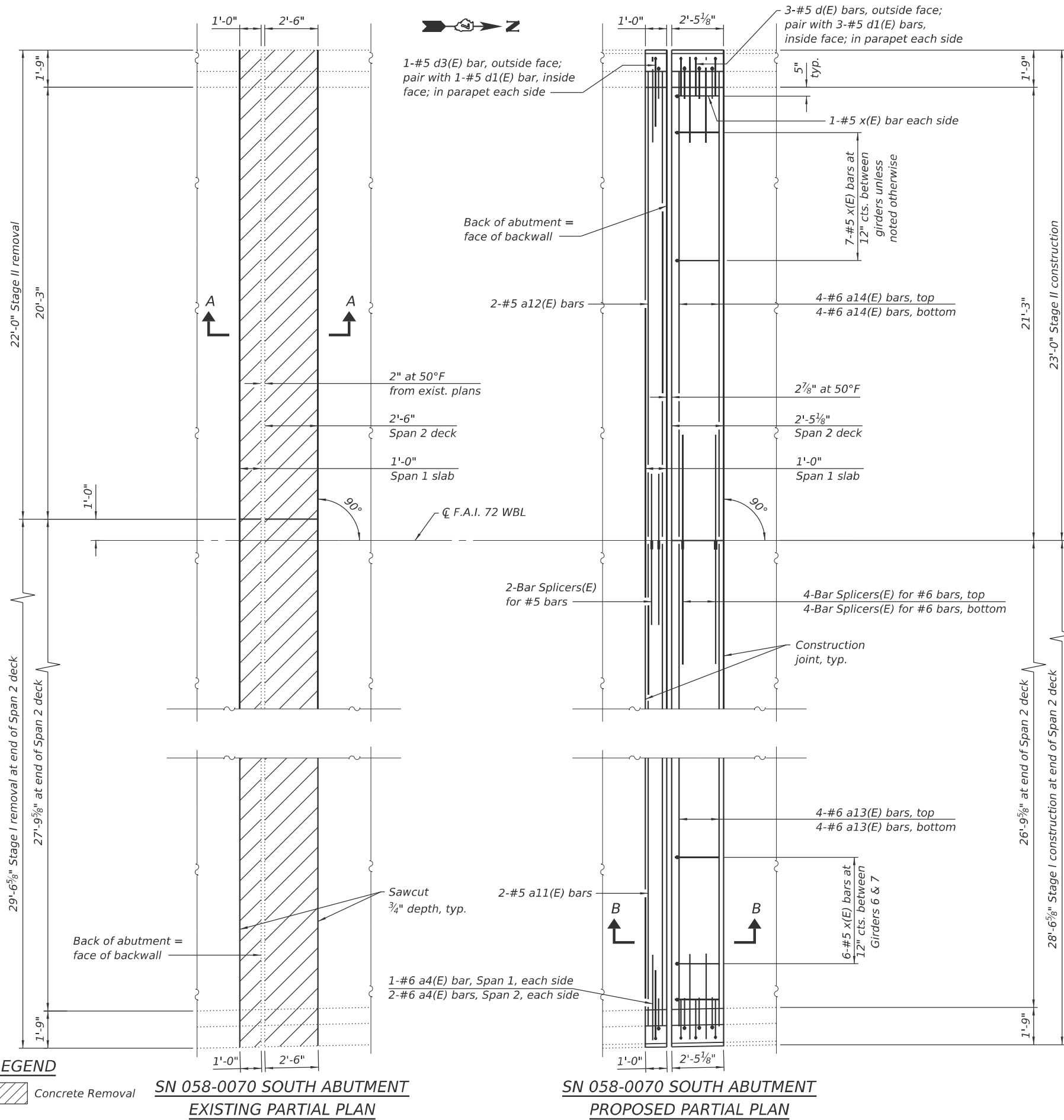

SN 058-0070 BILL OF MATERIAL
(South Abutment)

Bar	Number		Total	Size	Length	Shape	
	Stage I	Stage II					
a4(E)	3	3	6	#6	4'-0"	—	
a11(E)	2	0	2	#5	27'-5"	—	
a12(E)	0	2	2	#5	21'-10"	—	
a13(E)	8	0	8	#6	27'-5"	—	
a14(E)	0	8	8	#6	21'-10"	—	
d(E)	3	3	6	#5	4'-7"	J	
d1(E)	4	4	8	#5	3'-7"	J	
d2(E)	2	2	4	#4	2'-1"	U	
d3(E)	1	1	2	#5	6'-0"	J	
x(E)	21	22	43	#5	2'-8"	—	
Reinforcement Bars, Epoxy Coated						Pound	930
Concrete Removal						Cu. Yd.	6.9
Concrete Superstructure						Cu. Yd.	6.9
Bar Splicers						Each	10

Notes:
For Section A-A and Section B-B see Sheet 12 of 36.
Trim ends of existing longitudinal reinforcement in decks and parapets to provide minimum clearance for the expansion joint. Cost is included in Concrete Removal.

(Sheet 1 of 6)

MODEL: Sheet
FILE NAME: Y:\DOT\1445-01_74D08\74D08 DESIGN\CADD\SP_SN_058-0070-0071\COMMON SHEETS\0580070-D774D08-08-Expansion\01Dils.dgn



USER NAME = nhc
ESCA PROJECT NO. = 1445.01
PLOT SCALE = 0:2" = 1' / in.
PLOT DATE = 1/20/2026

DESIGNED - ELH 08/25
CHECKED - RDP 08/25
DRAWN - NHC 08/25
CHECKED - ELH 08/25

REVISED -
REVISED -
REVISED -
REVISED -

STATE OF ILLINOIS
DEPARTMENT OF TRANSPORTATION

EXPANSION JOINT REPLACEMENT DETAILS
SN 058-0070 (WB)

SHEET 8 OF 36 SHEETS

F.A.I. RTE.	SECTION	COUNTY	TOTAL SHEETS	SHEET NO.
72	D7 BRIDGE REPAIRS 2026-3	MACON	108	80
CONTRACT NO. 74D08				
ILLINOIS FED. AID PROJECT				

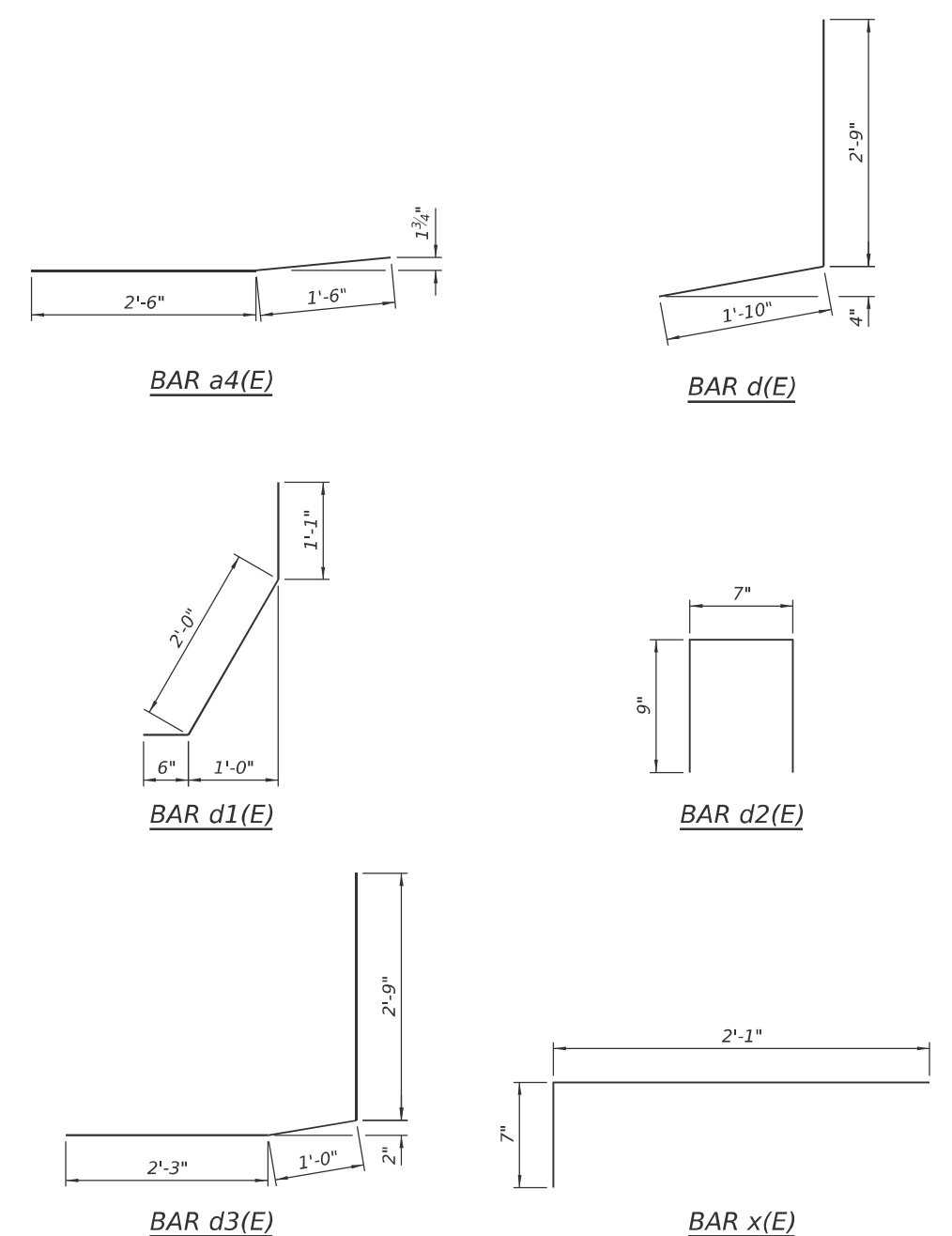
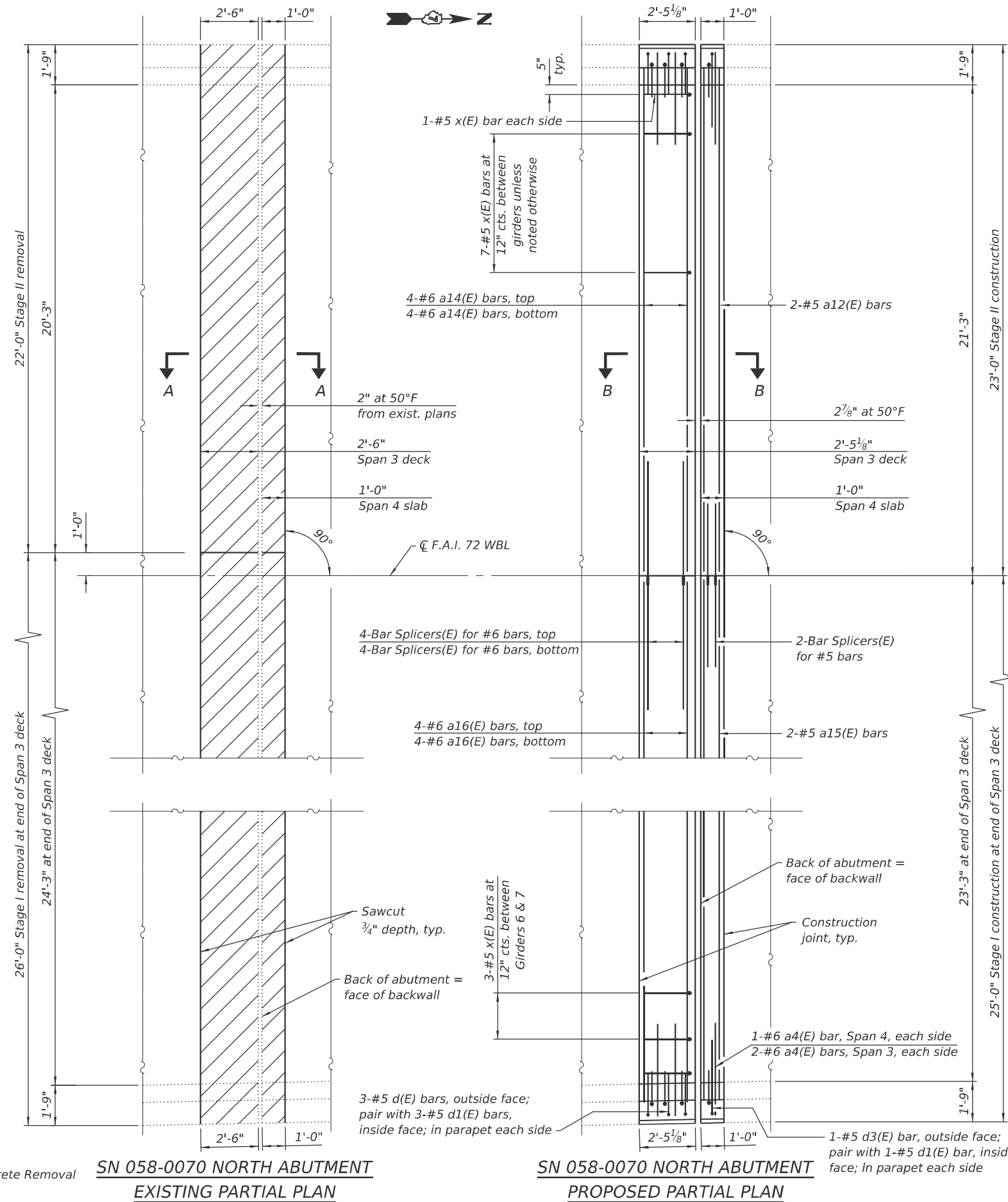

SN 058-0070 BILL OF MATERIAL
(North Abutment)

Bar	Number		Total	Size	Length	Shape	
	Stage I	Stage II					
a4(E)	3	3	6	#6	4'-0"	—	
a12(E)	0	2	2	#5	21'-10"	—	
a14(E)	0	8	8	#6	21'-10"	—	
a15(E)	2	0	2	#5	23'-10"	—	
a16(E)	8	0	8	#6	23'-10"	—	
d(E)	3	3	6	#5	4'-7"	J	
d1(E)	4	4	8	#5	3'-7"	J	
d2(E)	2	2	4	#4	2'-1"	□	
d3(E)	1	1	2	#5	6'-0"	J	
x(E)	18	22	40	#5	2'-8"	—	
Reinforcement Bars, Epoxy Coated						Pound	870
Concrete Removal						Cu. Yd.	6.6
Concrete Superstructure						Cu. Yd.	6.5
Bar Splicers						Each	10

Notes:
For Section A-A and Section B-B see Sheet 12 of 36.
Trim ends of existing longitudinal reinforcement in decks and parapets to provide minimum clearance for the expansion joint. Cost is included in Concrete Removal.

LEGEND



SN 058-0070 NORTH ABUTMENT
EXISTING PARTIAL PLAN

SN 058-0070 NORTH ABUTMENT
PROPOSED PARTIAL PLAN

STATE OF ILLINOIS
DEPARTMENT OF TRANSPORTATION

EXPANSION JOINT REPLACEMENT DETAILS
SN 058-0070 (WB)

SHEET 9 OF 36 SHEETS

F.A.I. RTE.	SECTION	COUNTY	TOTAL SHEETS	SHEET NO.
72	D7 BRIDGE REPAIRS 2026-3	MACON	108	81
CONTRACT NO. 74D08				
ILLINOIS FED. AID PROJECT				

MODEL: Sheet
FILE NAME: Y:\DOT\1445-01_74D08\74D08 DESIGN\CADD\SP SN 058-0070-0071\Common Sheets\0580070-D774D08-09-Expansion\01Dils.dgn
1/20/2026 1:55:44 PM



USER NAME = nhc
ESCA PROJECT NO. = 1445.01
PLOT SCALE = 0:2" = 1" / in.
PLOT DATE = 1/20/2026

DESIGNED - ELH 08/25
CHECKED - RDP 08/25
DRAWN - NHC 08/25
CHECKED - ELH 08/25

REVISED -
REVISED -
REVISED -
REVISED -

MODEL: Sheet
 FILE NAME: Y:\DOT\1445-01_74D08\74D08 DESIGN\CADD\SP SN 058-0071\0071-Expansion\JDL\1445-01-Expansion\JDL.dgn

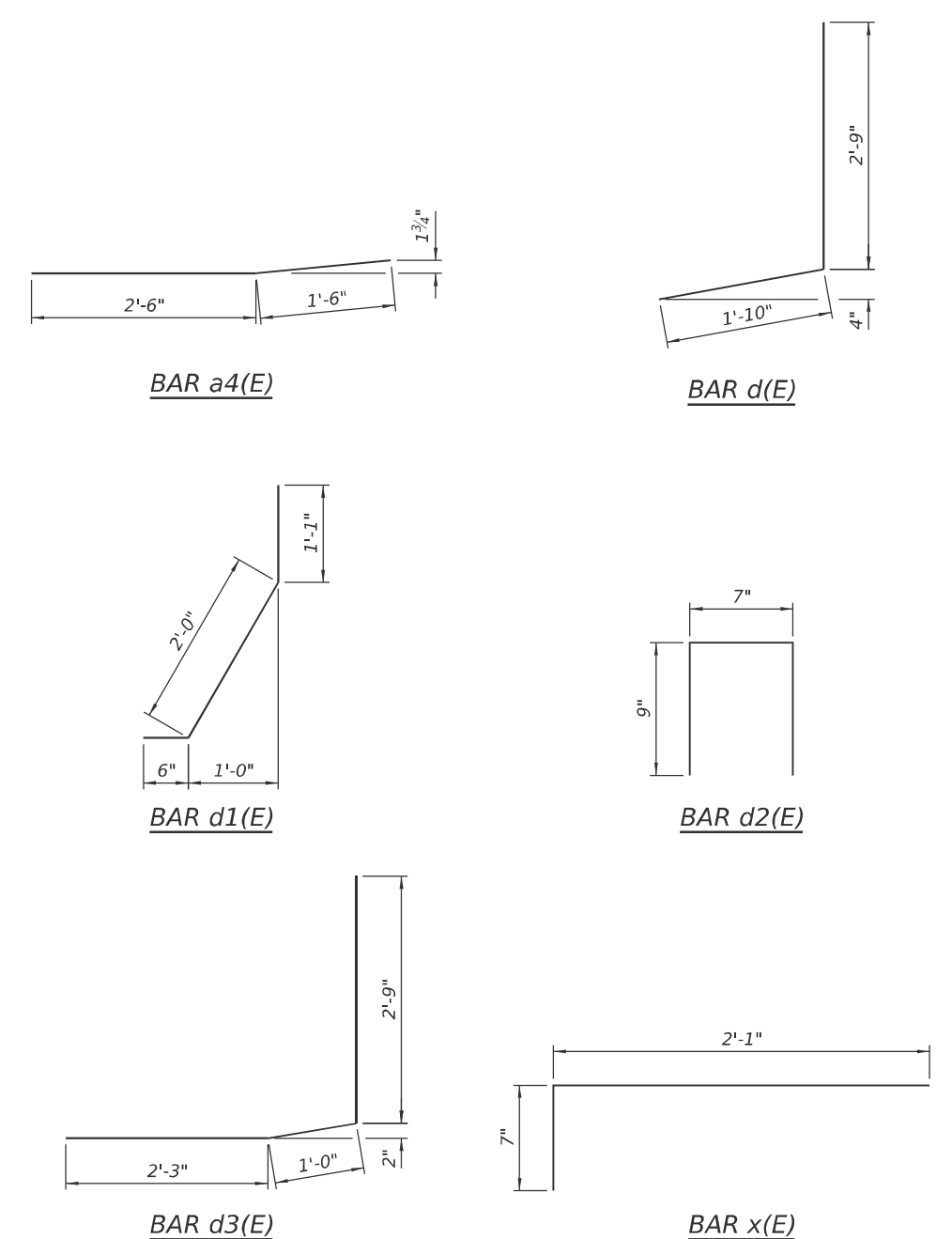
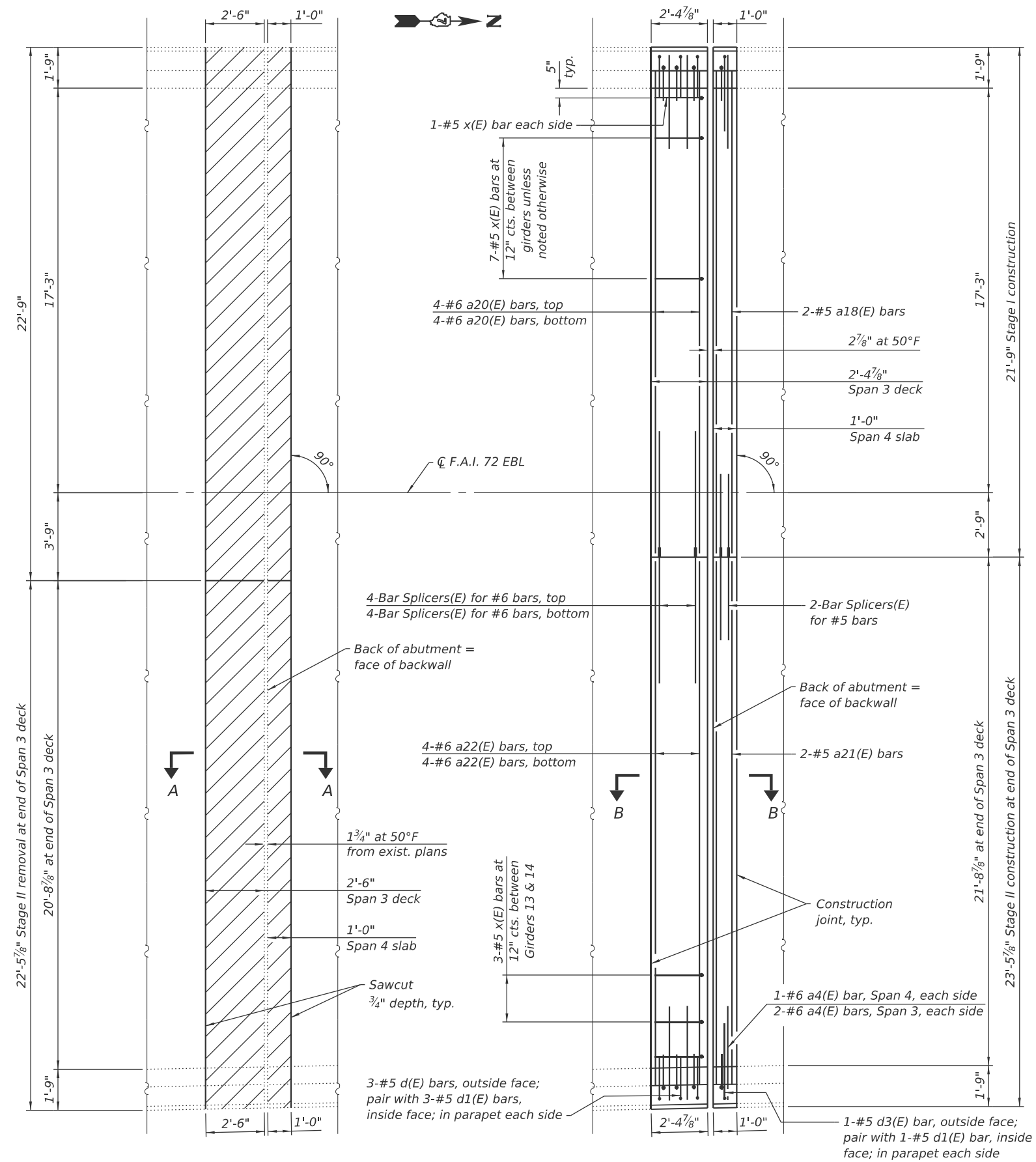

Notes:
 For Section A-A and Section B-B see Sheet 12 of 36.
 Trim ends of existing longitudinal reinforcement in decks and parapets to provide minimum clearance for the expansion joint. Cost is included in Concrete Removal.

SN 058-0071 BILL OF MATERIAL
 (North Abutment)

Bar	Number		Total	Size	Length	Shape	
	Stage I	Stage II					
a4(E)	3	3	6	#6	4'-0"	—	
a18(E)	2	0	2	#5	20'-7"	—	
a20(E)	8	0	8	#6	20'-7"	—	
a21(E)	0	2	2	#5	22'-4"	—	
a22(E)	0	8	8	#6	22'-4"	—	
d(E)	3	3	6	#5	4'-7"	J	
d1(E)	4	4	8	#5	3'-7"	J	
d2(E)	2	2	4	#4	2'-1"	□	
d3(E)	1	1	2	#5	6'-0"	J	
x(E)	19	21	40	#5	2'-8"	—	
Reinforcement Bars, Epoxy Coated						Pound	830
Concrete Removal						Cu. Yd.	6.0
Concrete Superstructure						Cu. Yd.	6.0
Bar Splicers						Each	10

LEGEND

Concrete Removal

SN 058-0071 NORTH ABUTMENT
EXISTING PARTIAL PLAN

SN 058-0071 NORTH ABUTMENT
PROPOSED PARTIAL PLAN

(Sheet 4 of 6)



USER NAME = nhc	DESIGNED - ELH 08/25	REVISED -
ESCA PROJECT NO. = 1445.01	CHECKED - RDP 08/25	REVISED -
PLOT SCALE = 0:2" = 1' / in.	DRAWN - NHC 08/25	REVISED -
PLOT DATE = 1/20/2026	CHECKED - ELH 08/25	REVISED -

STATE OF ILLINOIS
DEPARTMENT OF TRANSPORTATION

EXPANSION JOINT REPLACEMENT DETAILS
SN 058-0071 (EB)

SHEET 11 OF 36 SHEETS

F.A.I. RTE. 72	SECTION D7 BRIDGE REPAIRS 2026-3	COUNTY MACON	TOTAL SHEETS 108	SHEET NO. 83
ILLINOIS FED. AID PROJECT			CONTRACT NO. 74D08	

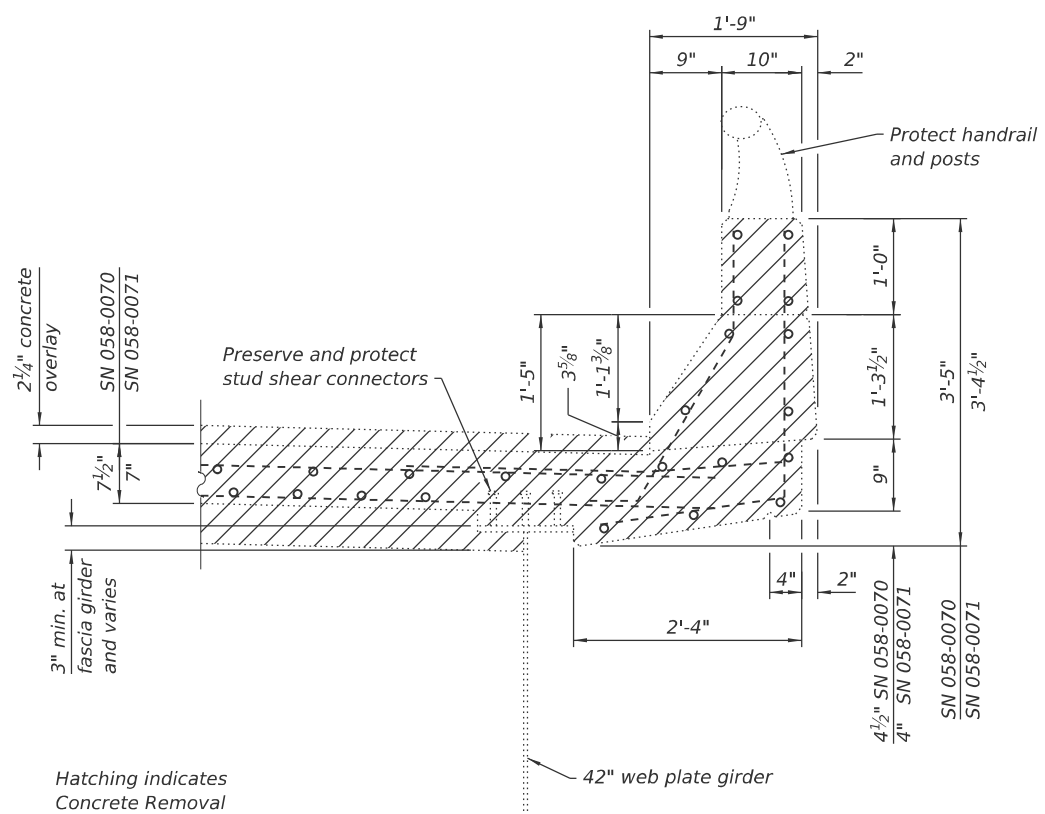

SECTION THRU EXISTING PARAPET AT MAIN SPANS

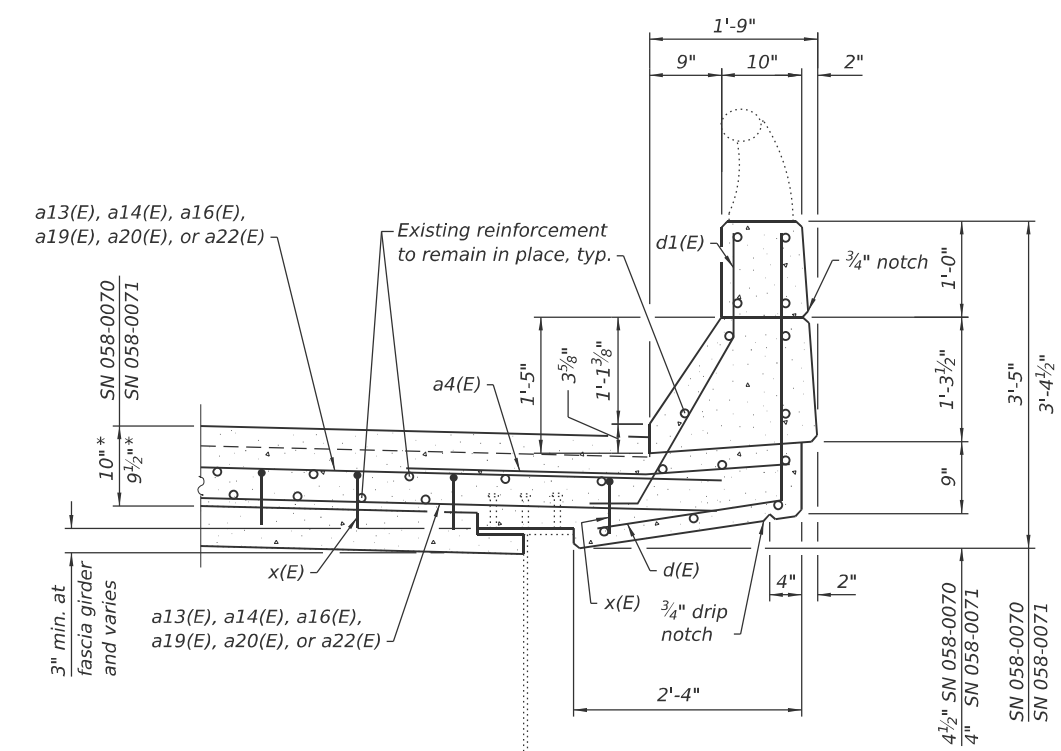

SECTION THRU PROPOSED PARAPET AT MAIN SPANS

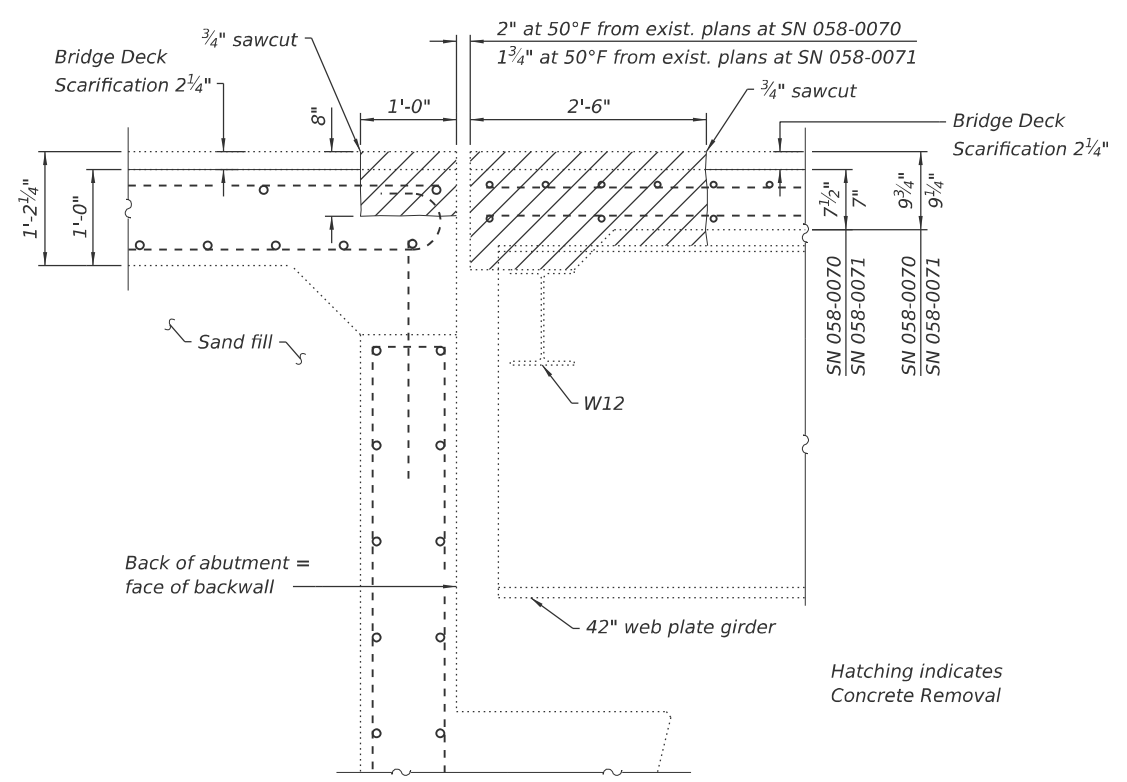

SECTION A-A

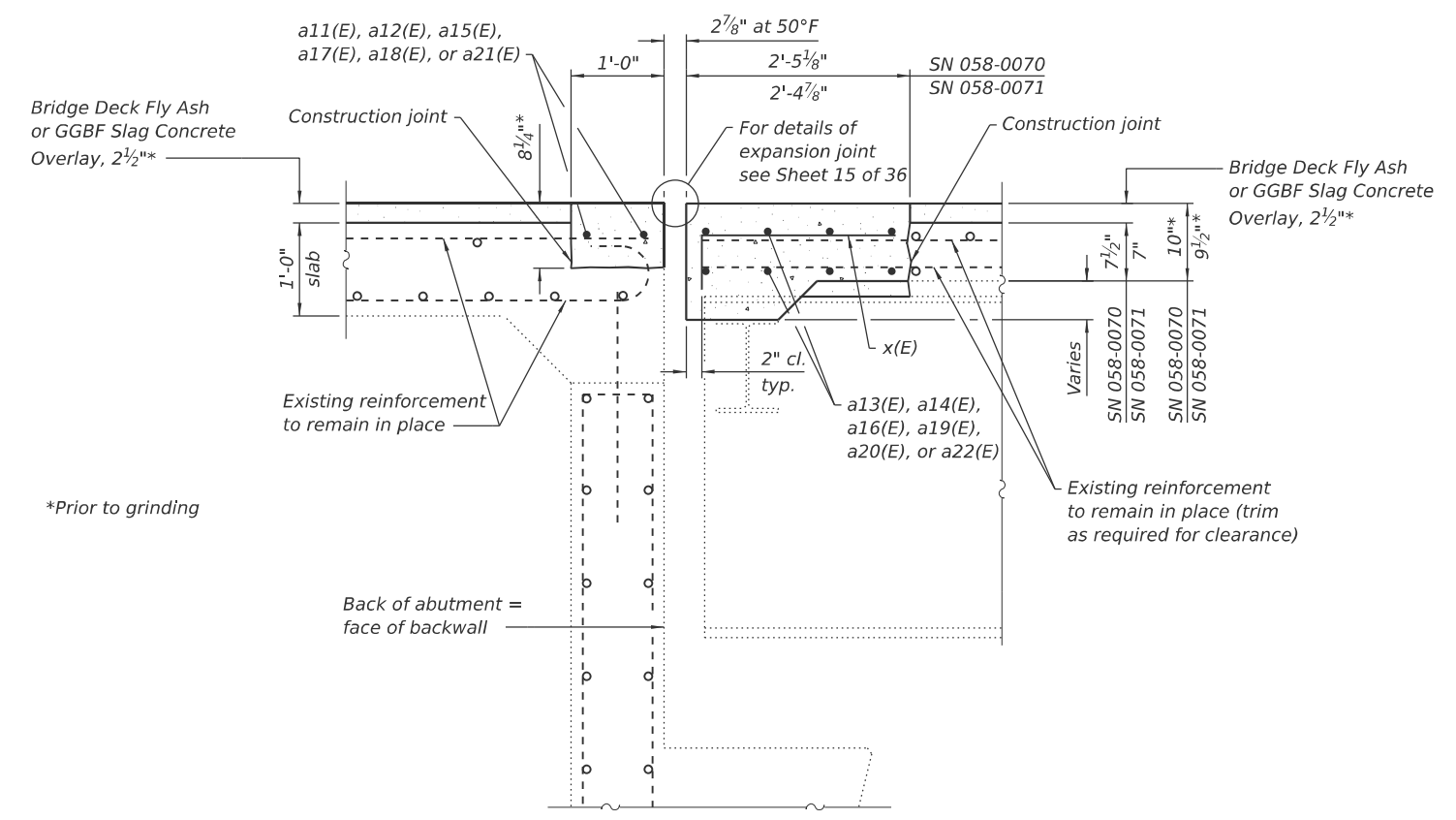

SECTION B-B

(Sheet 5 of 6)

MODEL: Sheet
 FILE NAME: Y:\IDOT\1445-01_74D08\74D08 DESIGN\CADD\SP_S058-0070-0071\Common Sheets\0580070-0071-4D08-12-Expansion\ID15.dgn
 1/20/2026 1:55:46 PM



USER NAME = nhc	DESIGNED - ELH 08/25	REVISED -
ESCA PROJECT NO. = 1445.01	CHECKED - RDP 08/25	REVISED -
PLOT SCALE = 0.2" / in.	DRAWN - NHC 08/25	REVISED -
PLOT DATE = 1/20/2026	CHECKED - ELH 08/25	REVISED -

STATE OF ILLINOIS
 DEPARTMENT OF TRANSPORTATION

EXPANSION JOINT REPLACEMENT DETAILS
 SN 058-0070 (WB) & SN 058-0071 (EB)

SHEET 12 OF 36 SHEETS

F.A.I. RTE.	SECTION	COUNTY	TOTAL SHEETS	SHEET NO.
72	D7 BRIDGE REPAIRS 2026-3	MACON	108	84
CONTRACT NO. 74D08				
ILLINOIS FED. AID PROJECT				

Notes:

Fiberglass pipe shall conform to ASTM D2996, with short-time rupture strength hoop tensile stress of 30,000 p.s.i. minimum.

The exterior surfaces of the floor drains shall be painted according to Article 506 with the finish coat as specified. The exterior surfaces of the drains shall be cleaned according to the Society of Protective Coating's Spec. SSPC-SP1 prior to painting.

The top portion of aluminum floor drains shall be coated with 5 mils of either bitumen paint or epoxy paint to minimize reaction with wet concrete.

The clamping device shall be galvanized according to AASHTO M 232. Cost of clamping device included with Floor Drains.

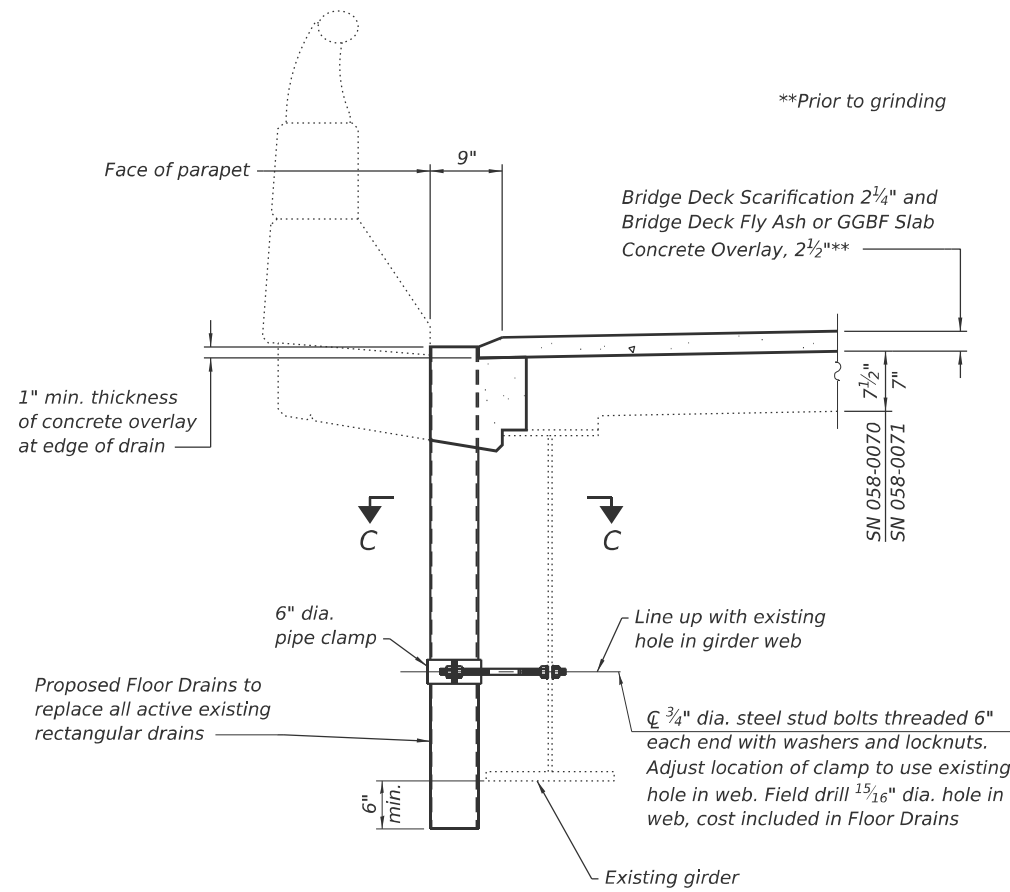

SECTION THRU PROPOSED FLOOR DRAIN

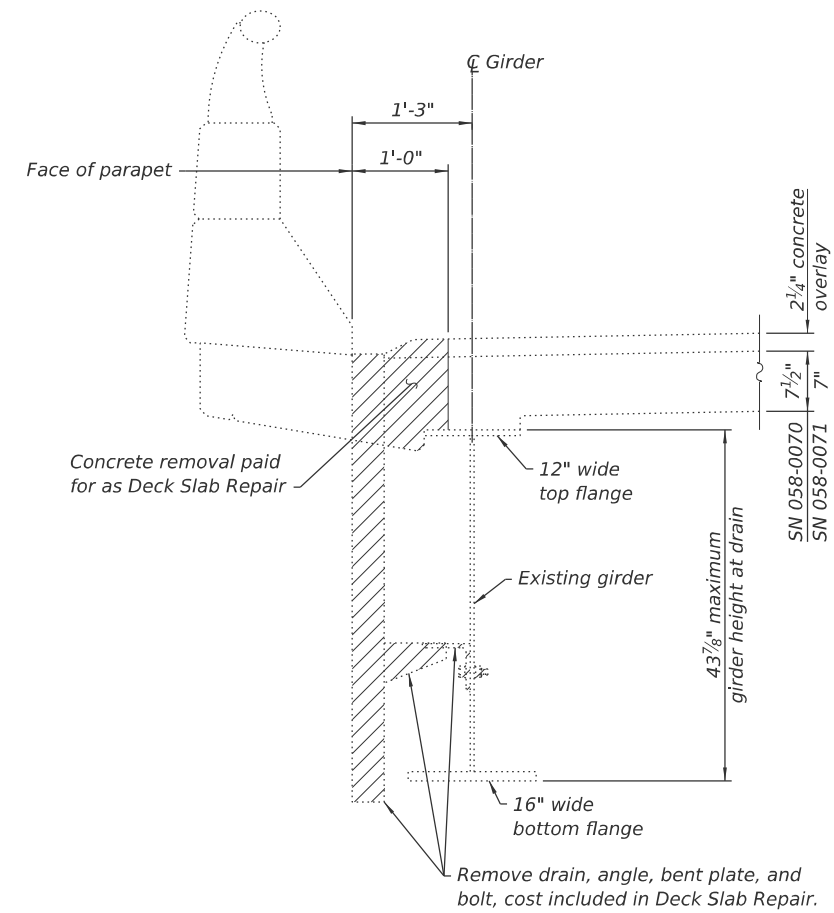

SECTION THRU EXISTING DECK DRAIN

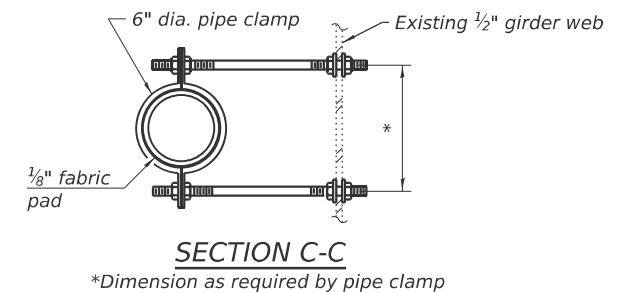
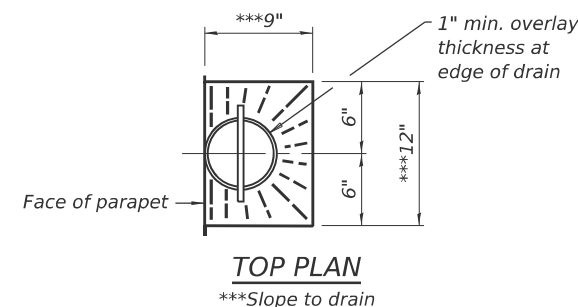
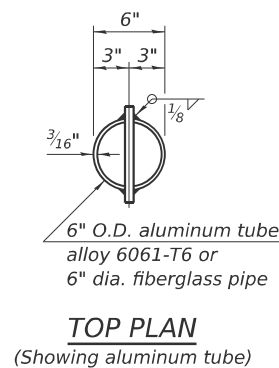
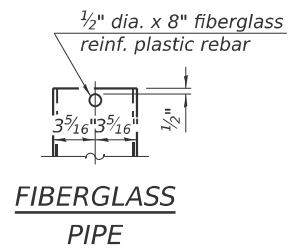
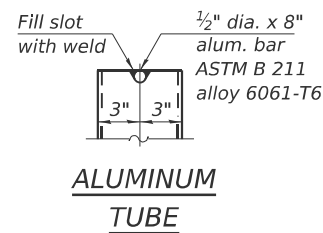

MODEL: Sheet
FILE NAME: Y:\DOT\1445-01_74D08\74D08 DESIGN\CADD\SP_SN_058-0070-0071\1445-01-74D08-14-DeckDrainDtls.dgn



USER NAME = nhc
ESCA PROJECT NO. = 1445.01
PLOT SCALE = 0.2" = 1" / in.
PLOT DATE = 1/20/2026

DESIGNED - ELH 07/25
CHECKED - RDP 07/25
DRAWN - NHC 07/25
CHECKED - ELH 07/25

REVISED -
REVISED -
REVISED -
REVISED -

STATE OF ILLINOIS
DEPARTMENT OF TRANSPORTATION

DECK DRAIN DETAILS
SN 058-0070 (WB) & SN 058-0071 (EB)

SHEET 14 OF 36 SHEETS

F.A.I. RTE.	SECTION	COUNTY	TOTAL SHEETS	SHEET NO.
72	D7 BRIDGE REPAIRS 2026-3	MACON	108	86
CONTRACT NO. 74D08				
ILLINOIS FED. AID PROJECT				

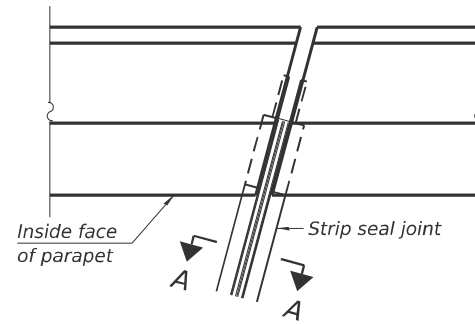

FOR SKEWS $\leq 30^\circ$
PLAN AT PARAPET

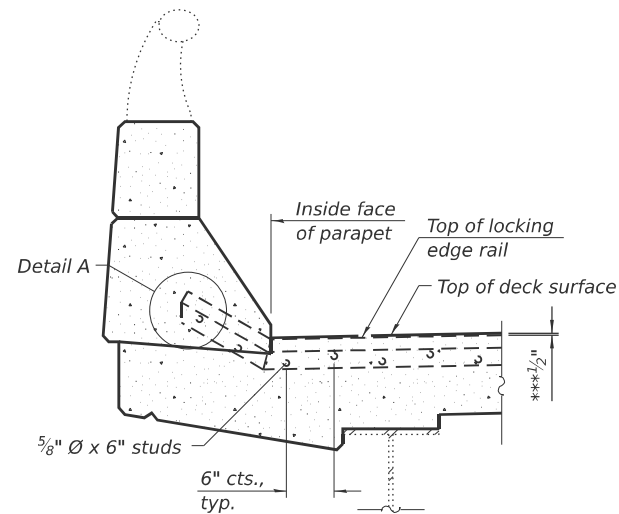

SECTION AT PARAPET

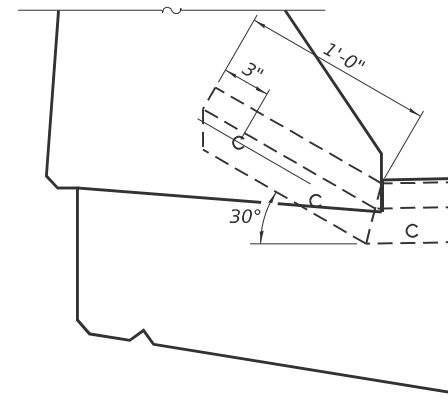

DETAIL A

Notes:
 The strip seal shall be made continuous and shall have a minimum thickness of $\frac{1}{4}$ ". The configuration of the strip seal shall match the configuration of the locking edge rails. Open or "webbed" strip seal gland configurations are not permitted. The gland shall be sized for a maximum rated movement of 4 inches.
 The locking edge rails depicted are configured for typical applications and are conceptual only. The actual configuration of the locking edge rails and matching strip seal may vary from manufacturer to manufacturer provided they fit the application and meet the minimum anchorage shown. Flanged edge rails, however, will not be allowed. Locking edge rails may exceed the $4\frac{1}{2}$ " maximum depth provided the anchorage system is revised according to the manufacturer's recommendation.
 The manufacturer's recommended installation methods shall be followed.
 All steel components shall be galvanized after fabrication according to Article 520.03 of the Standard Specifications.
 The maximum space between locking edge rail segments shall be $\frac{3}{16}$ " and sealed with a suitable sealant; however, any rail joint within 10' measured perpendicular to the face of the curb or parapet shall be welded as shown in the locking edge rail splice detail.
 The concrete opening below the strip seal will vary based on the locking edge rail chosen by the Contractor. Deck and parapet lengths shown elsewhere in the plans are dimensioned to the concrete opening, not the joint opening, and are based on the rolled locking edge rail. If the Contractor elects to use a different locking edge rail, dimensional adjustments may be required.

***Prior to grinding

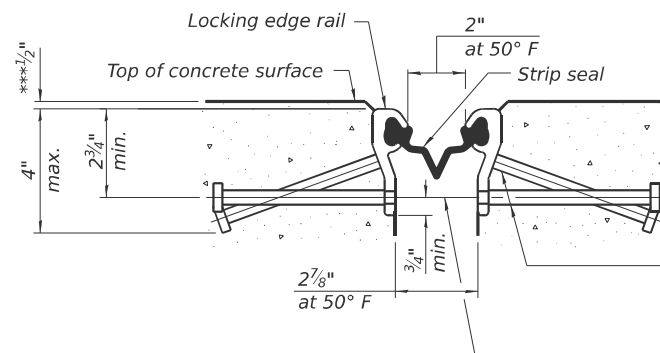

SHOWING ROLLED RAIL JOINT

* $\frac{5}{8}$ " \varnothing x 6" studs @ 6" cts. (alternate angled/bent studs with horizontal studs)

$\frac{3}{8}$ " \varnothing threaded rods in $\frac{7}{16}$ " \varnothing holes at 4'-0" \pm cts. for holding the proper joint opening based on the temperature during the deck pour. Place to miss studs. All rods shall be burned, or sawed off flush with the plates after concrete is set.

SECTION A-A

* Granular or solid flux filled headed studs conforming to Article 1006.32 of the Std. Specs., automatically end welded.

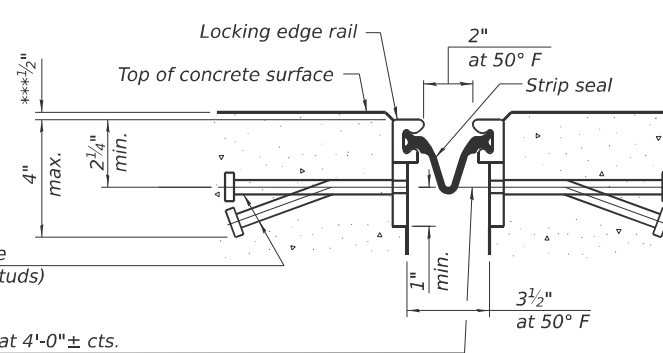

SHOWING WELDED RAIL JOINT

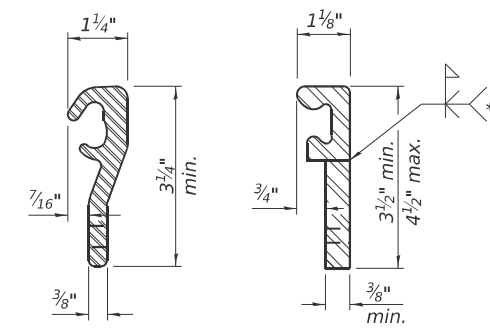

LOCKING EDGE RAILS

** Back gouge not required if complete joint penetration is verified by mock-up.

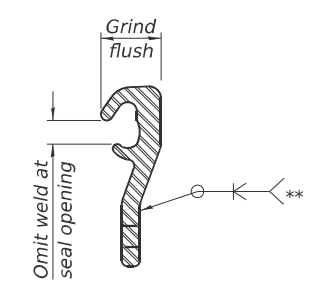

LOCKING EDGE RAIL SPLICE

The inside of the locking edge rail groove shall be free of weld residue. Rolled rail shown, welded rail similar.

SN 058-0070 & SN 058-0071

BILL OF MATERIAL

Item	Unit	Quantity
Preformed Joint Strip Seal	Foot	188

MODEL: Sheet
 FILE NAME: Y:\DOT11445-01_74D08\74D08 DESIGN\CADD\SP SN 058-0070-0071\Common Sheets\0580070-D774D08-15-P-US.dgn



USER NAME = nhc
 ESCA PROJECT NO. = 1445.01
 PLOT SCALE = 0.2" = 1' / in.
 PLOT DATE = 1/20/2026

DESIGNED - ELH 08/25
 CHECKED - RDP 08/25
 DRAWN - NHC 08/25
 CHECKED - ELH 08/25

REVISED -
 REVISED -
 REVISED -
 REVISED -

**STATE OF ILLINOIS
 DEPARTMENT OF TRANSPORTATION**

**PREFORMED JOINT STRIP SEAL
 SN 058-0070 (WB) & SN 058-0071 (EB)**

SHEET 15 OF 36 SHEETS

F.A.I. RTE.	SECTION	COUNTY	TOTAL SHEETS	SHEET NO.
72	D7 BRIDGE REPAIRS 2026-3	MACON	108	87

CONTRACT NO. 74D08
 ILLINOIS FED. AID PROJECT

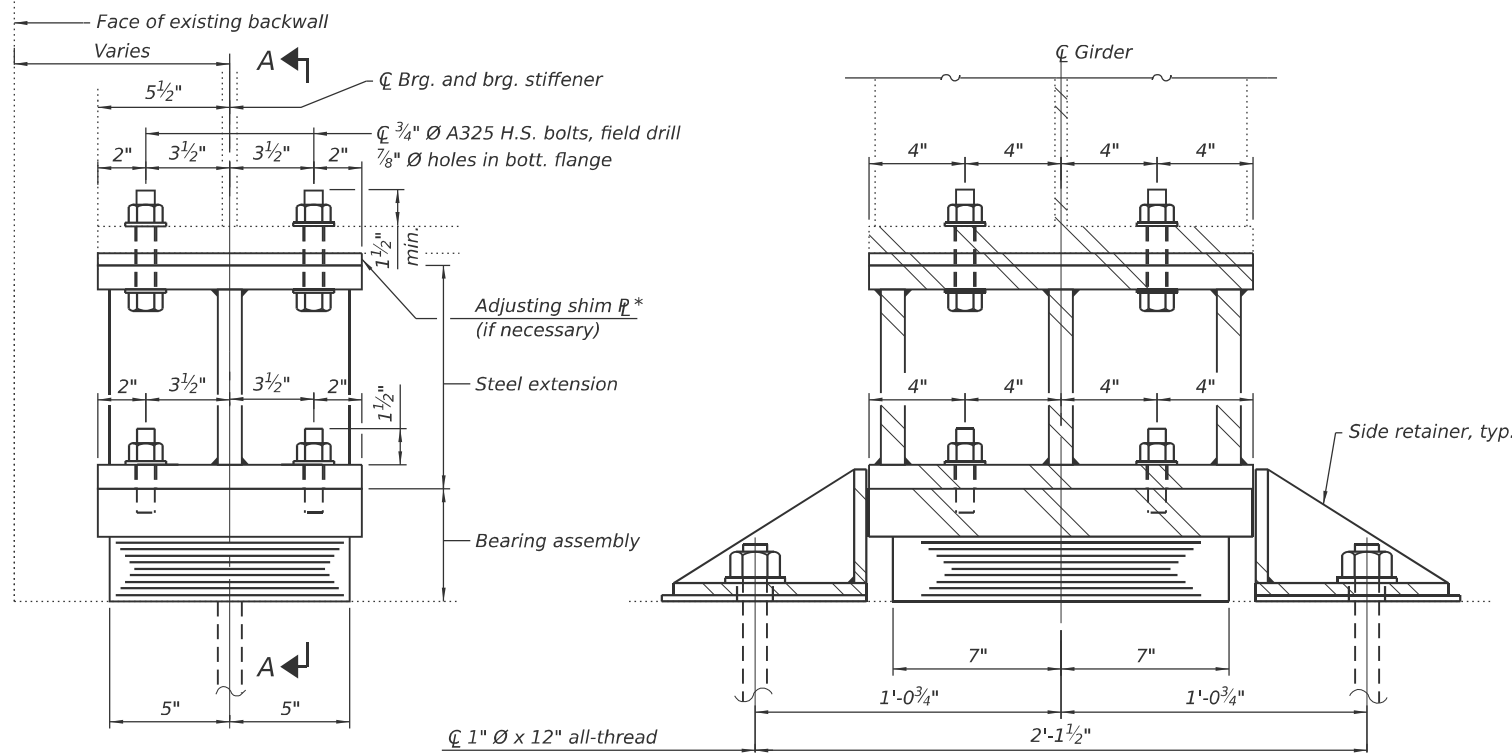

ELEVATION AT ABUT.

*See Shim Plate Tables

1" \varnothing x 12" all-thread anchor bolts (F1554 Grade 55) with 2 1/4" x 2 1/4" x 5/16" \varnothing washer under nut

TYPE I ELASTOMERIC EXP. BRG.

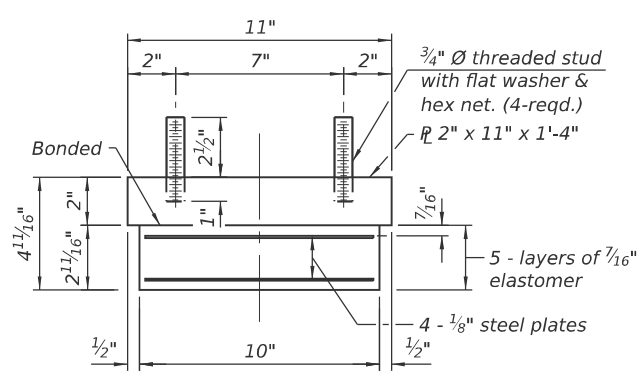

BEARING ASSEMBLY

Note:
Shim plates shall not be placed under bearing assembly.

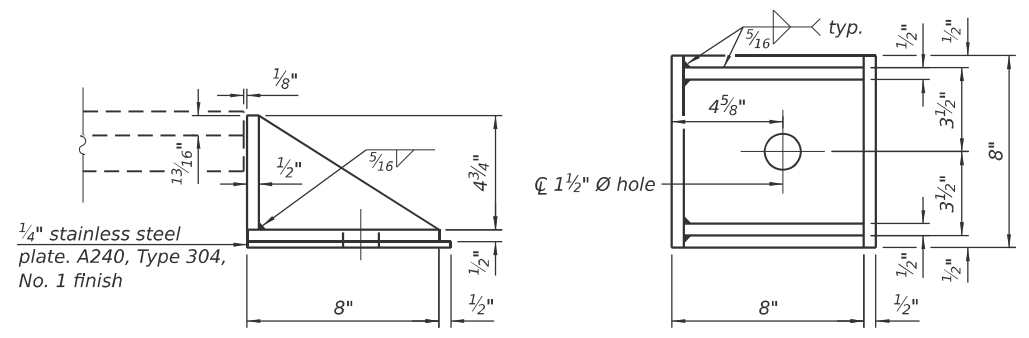

SIDE RETAINER

Equivalent rolled angle with stiffeners will be allowed in lieu of welded plates.

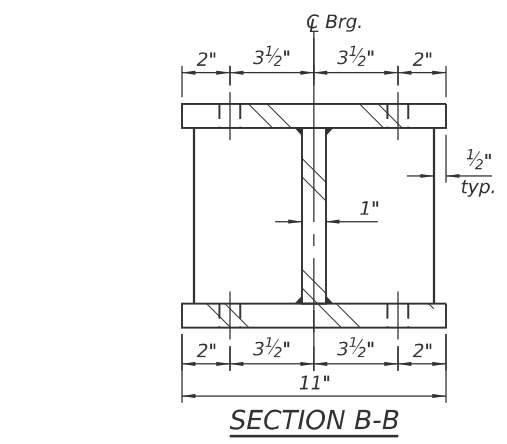

SECTION B-B

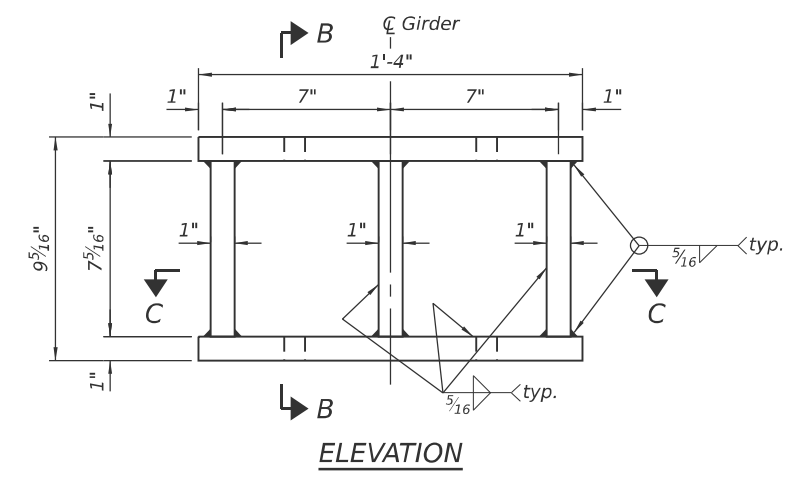

ELEVATION

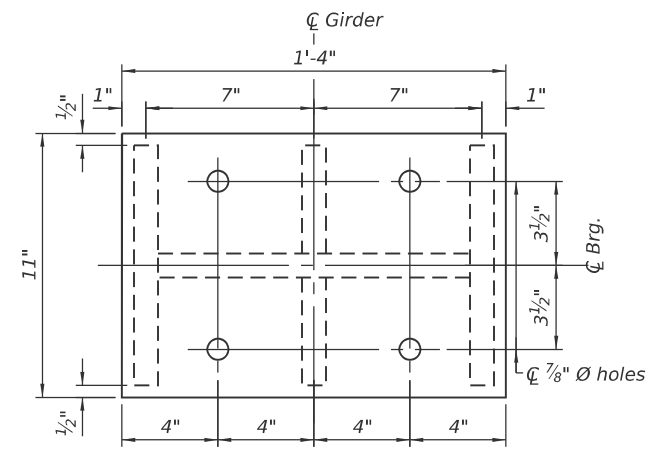

PLAN

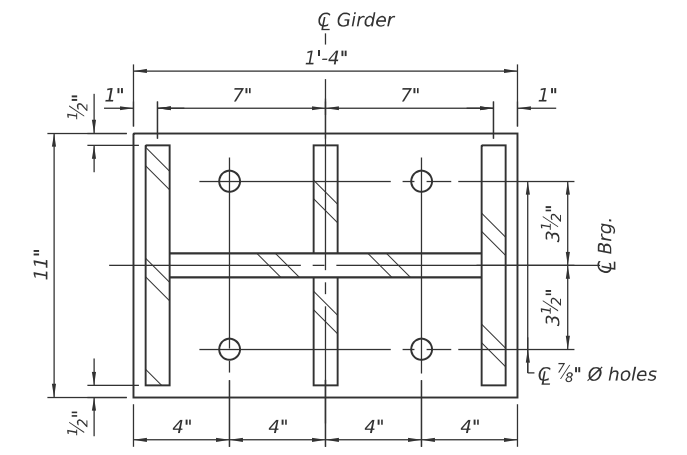

SECTION C-C

FABRICATED STEEL EXTENSION

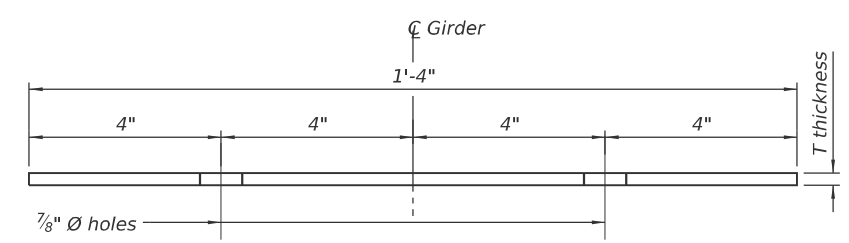

SHIM PLATE

See Shim Plate Tables for thickness

SN 058-0070 SHIM PLATE TABLE

Beam No.	North Abutment	South Abutment
	T	T
1	0	0
2	0	1/8"
3	0	0
4	1/4"	3/4"
5	0	0
6	0	0
7	0	0

SN 058-0071 SHIM PLATE TABLE

Beam No.	North Abutment	South Abutment
	T	T
8	0	0
9	0	0
10	0	0
11	0	0
12	0	0
13	0	0
14	1 1/4"	0

SN 058-0070 BEAM REACTION TABLE

Existing Service Loads	
R _{DL} (k)	44.7
R _L (k)	49.0
R _{IM} (k)	11.5
R _{TOTAL} (k)	105.2

SN 058-0071 BEAM REACTION TABLE

Existing Service Loads	
R _{DL} (k)	41.5
R _L (k)	45.7
R _{IM} (k)	10.7
R _{TOTAL} (k)	97.9

(Sheet 1 of 2)

MODEL: Sheet
FILE NAME: Y:\IDOT\1445-01_74D08\74D08 DESIGN\CADD\SP_SN_058-0070-0071\Common Sheets\0580070-D774D08-16-BearingDtls.dgn



USER NAME = nhc
ESCA PROJECT NO. = 1445.01
PLOT SCALE = 0:2" = 1'
PLOT DATE = 1/21/2026

DESIGNED - ELH 01/26
CHECKED - RDP 01/26
DRAWN - NHC 01/26
CHECKED - ELH 01/26

REVISED -
REVISED -
REVISED -
REVISED -

STATE OF ILLINOIS
DEPARTMENT OF TRANSPORTATION

BEARING DETAILS
SN 058-0070 (WB) & SN 058-0071 (EB)

SHEET 16 OF 36 SHEETS

F.A.I. RTE.	SECTION	COUNTY	TOTAL SHEETS	SHEET NO.
72	D7 BRIDGE REPAIRS 2026-3	MACON	108	88

CONTRACT NO. 74D08
ILLINOIS FED. AID PROJECT

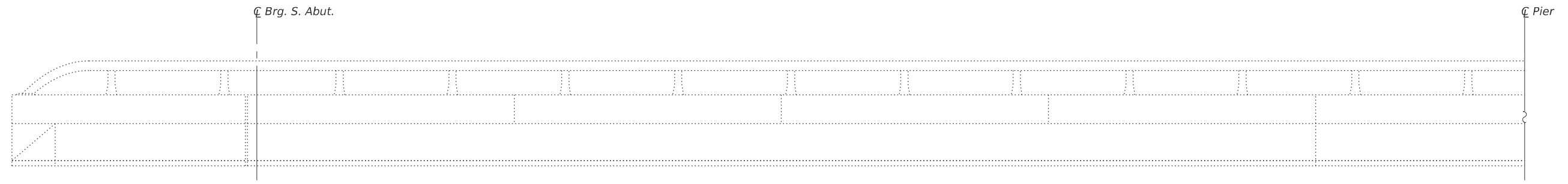

WEST RAILING INSIDE ELEVATION

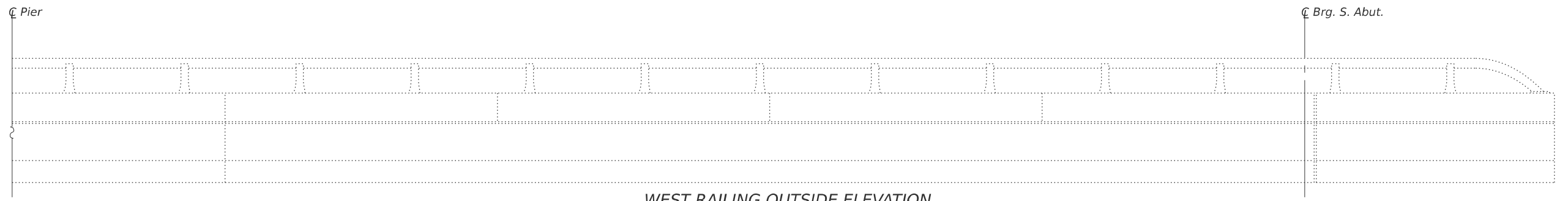
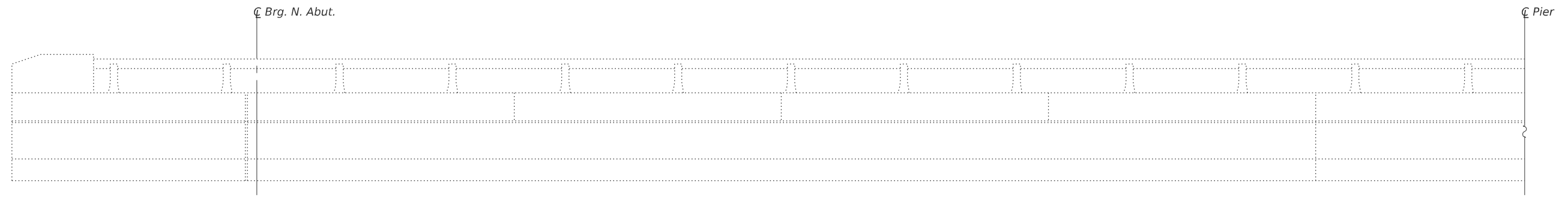

WEST RAILING OUTSIDE ELEVATION

LEGEND

 Structural Repair of Concrete (Depth Equal to or Less Than 5 Inches)

MODEL: Sheet
FILE NAME: Y:\DOT1445-01_Z4D0874D08 DESIGN\CADD\SP_S058-0070-0071\Common Sheets\0580070-0071-18-ParapetRepairs(WB).dgn

(Sheet 1 of 4)



USER NAME = nhc	DESIGNED - ELH 07/25	REVISED -
ESCA PROJECT NO. = 1445.01	CHECKED - RDP 07/25	REVISED -
PLOT SCALE = 0.2" / in.	DRAWN - ZTC 07/25	REVISED -
PLOT DATE = 1/20/2026	CHECKED - ELH 07/25	REVISED -

**STATE OF ILLINOIS
DEPARTMENT OF TRANSPORTATION**

**PARAPET REPAIRS
SN 058-0070 (WB)**

SHEET 18 OF 36 SHEETS

F.A.I. RTE.	SECTION	COUNTY	TOTAL SHEETS	SHEET NO.
72	D7 BRIDGE REPAIRS 2026-3	MACON	108	90
CONTRACT NO. 74D08				
ILLINOIS FED. AID PROJECT				

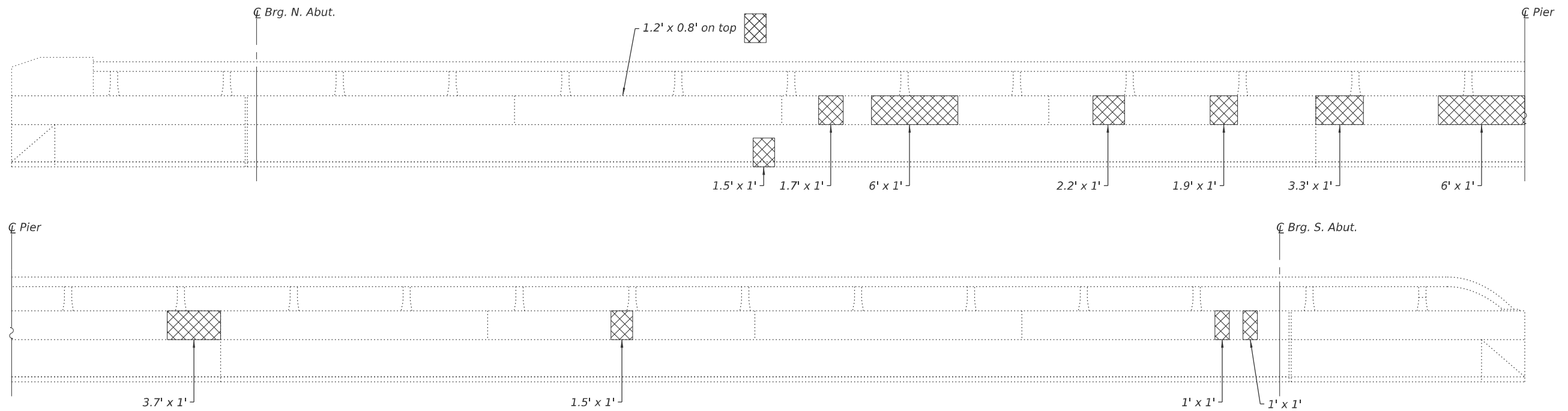

EAST RAILING INSIDE ELEVATION



EAST RAILING OUTSIDE ELEVATION

LEGEND

 Structural Repair of Concrete (Depth Equal to or Less Than 5 Inches)

SN 058-0070 BILL OF MATERIAL

Item	Unit	Quantity
Structural Repair of Concrete (Depth Equal to or Less Than 5 Inches)	Sq. Ft.	32.9

(Sheet 2 of 4)

MODEL: Sheet FILE NAME: Y:\DOT11445-01_74D08\74D08 DESIGN\CADD\SP SN 058-0070-0071\Common Sheets\0580070-D774D08-19-ParapetRepairs(WB).dgn



USER NAME = nhc
 ESCA PROJECT NO. = 1445.01
 PLOT SCALE = 0.2" / in.
 PLOT DATE = 1/20/2026

DESIGNED - ELH 07/25
 CHECKED - RDP 07/25
 DRAWN - ZTC 07/25
 CHECKED - ELH 07/25

REVISED -
 REVISED -
 REVISED -
 REVISED -

**STATE OF ILLINOIS
 DEPARTMENT OF TRANSPORTATION**

**PARAPET REPAIRS
 SN 058-0070 (WB)**

SHEET 19 OF 36 SHEETS

F.A.I. RTE.	SECTION	COUNTY	TOTAL SHEETS	SHEET NO.
72	D7 BRIDGE REPAIRS 2026-3	MACON	108	91
CONTRACT NO. 74D08				
ILLINOIS FED. AID PROJECT				

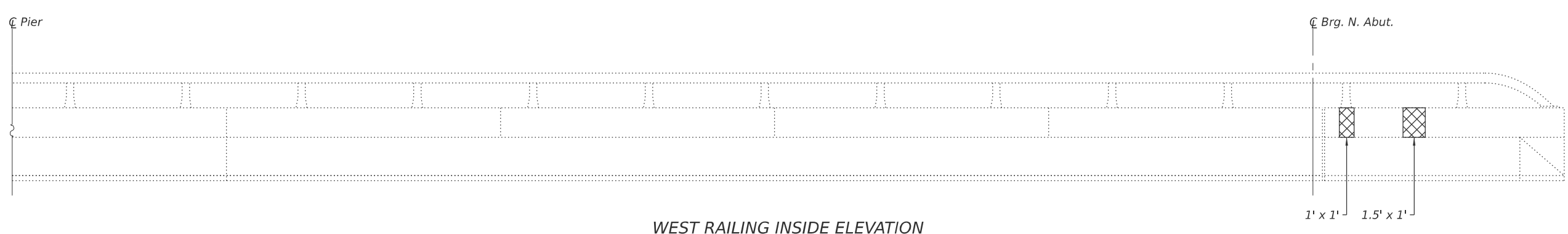
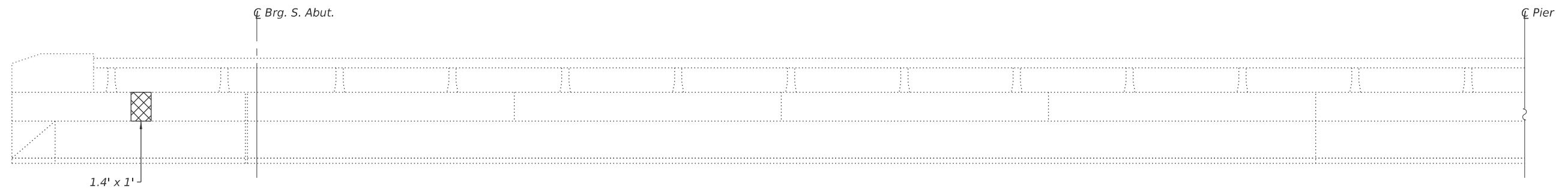

WEST RAILING INSIDE ELEVATION

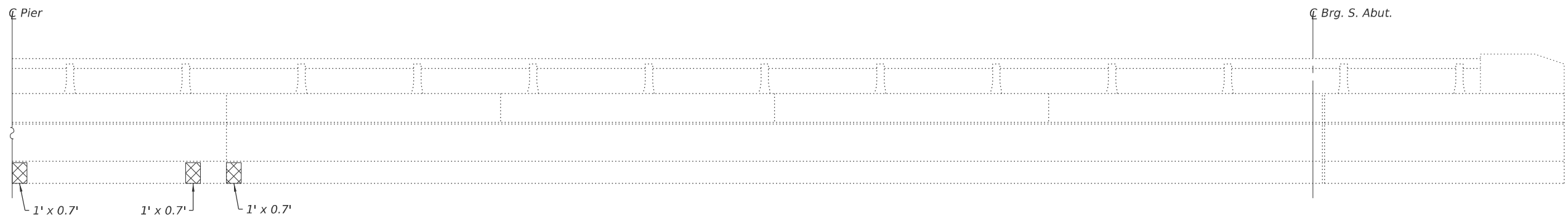
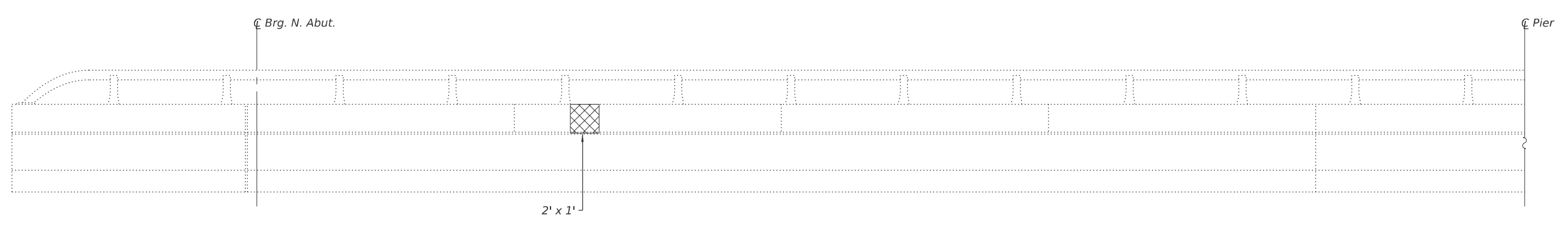

WEST RAILING OUTSIDE ELEVATION

LEGEND

 Structural Repair of Concrete (Depth Equal to or Less Than 5 Inches)

MODEL: Sheet
FILE NAME: Y:\DOT1445-01_74D08\74D08 DESIGN\CADD\SP_S\058-0071-0071\Common Sheets\0580070-D774D08-20-ParapetRepairs(EB).dgn

(Sheet 3 of 4)



USER NAME = nhc
ESCA PROJECT NO. = 1445.01
PLOT SCALE = 0.2" / in.
PLOT DATE = 1/20/2026

DESIGNED - ELH 07/25
CHECKED - RDP 07/25
DRAWN - ZTC 07/25
CHECKED - ELH 07/25

REVISED -
REVISED -
REVISED -
REVISED -

**STATE OF ILLINOIS
DEPARTMENT OF TRANSPORTATION**

**PARAPET REPAIRS
SN 058-0071 (EB)**

SHEET 20 OF 36 SHEETS

F.A.I. RTE.	SECTION	COUNTY	TOTAL SHEETS	SHEET NO.
72	D7 BRIDGE REPAIRS 2026-3	MACON	108	92
CONTRACT NO. 74D08				
ILLINOIS FED. AID PROJECT				

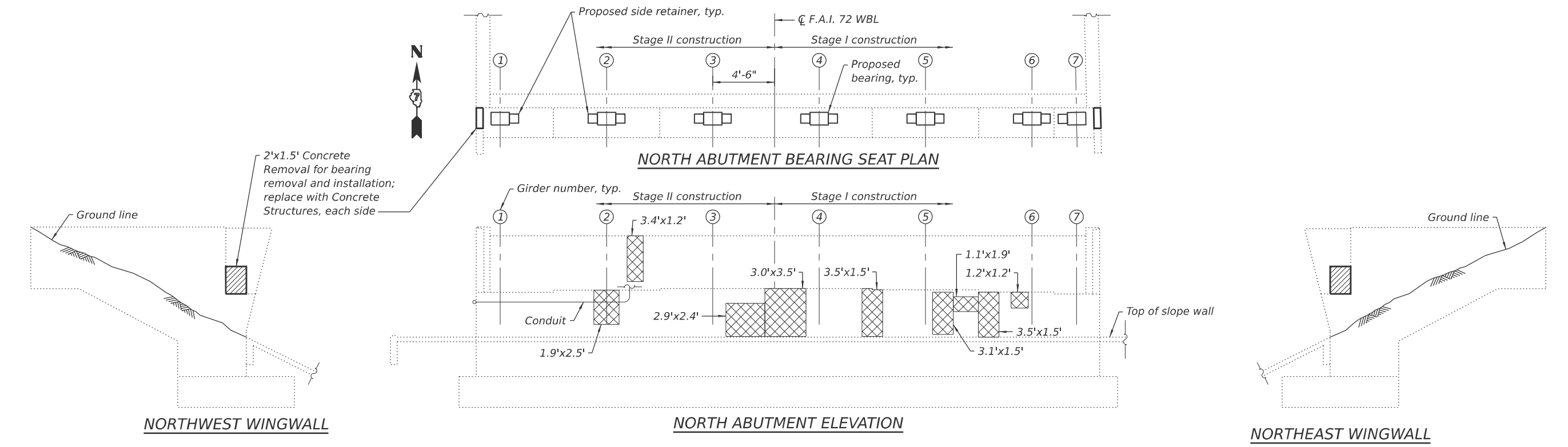
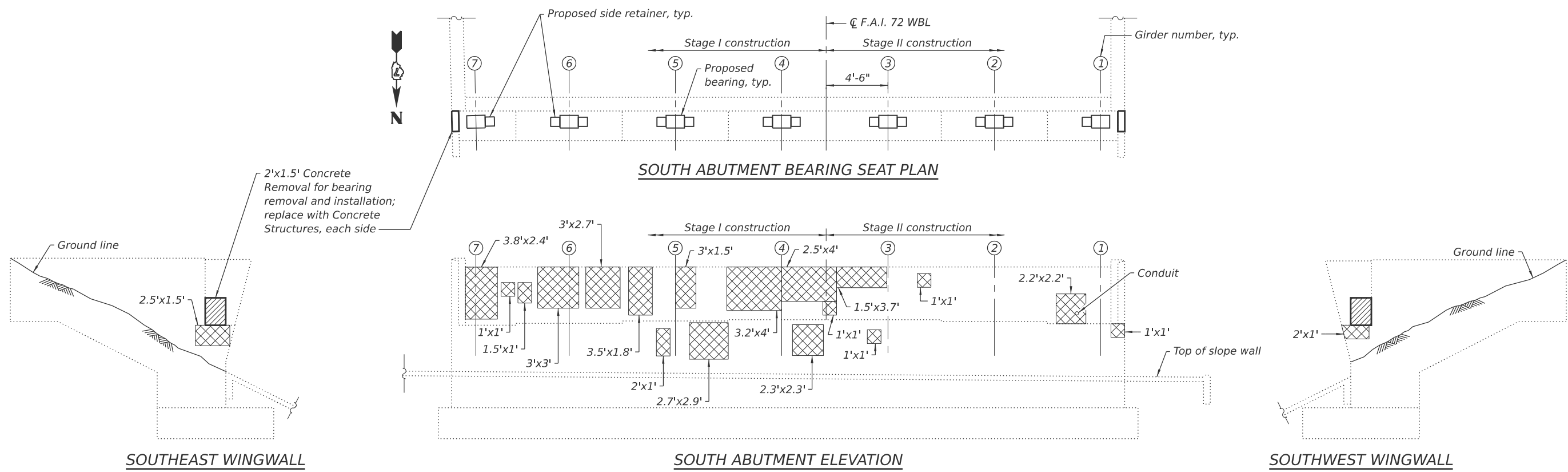

Note:
1. Abutment repairs shall be staged according to the same dimensions and locations as shown for the superstructure.

LEGEND
 Structural Repair of Concrete (Depth Equal to or Less Than 5 Inches)

SN 058-0070 BILL OF MATERIAL

Item	Unit	Quantity
Structural Repair of Concrete (Depth Equal to or Less Than 5 Inches)	Sq. Ft.	142.6
Concrete Removal	Cu. Yd.	0.3
Concrete Structures	Cu. Yd.	0.3

MODEL: Sheet
 FILE NAME: Y:\ID0711445-01_74D08\74D08 DESIGN\CADD\SP SN 058-0070-0071\Common Sheets\0580070-D774D08-22-AbutRepairs(WB).dgn
 1/20/2026 1:55:51 PM



USER NAME = nhc
 ESCA PROJECT NO. = 1445.01
 PLOT SCALE = 0.2" / in.
 PLOT DATE = 1/20/2026

DESIGNED - ELH 08/25
 CHECKED - RDP 08/25
 DRAWN - NHC 08/25
 CHECKED - ELH 08/25

REVISED -
 REVISED -
 REVISED -
 REVISED -

**STATE OF ILLINOIS
 DEPARTMENT OF TRANSPORTATION**

**ABUTMENT REPAIRS
 SN 058-0070 (WB)**
 SHEET 22 OF 36 SHEETS

F.A.I. RTE.	SECTION	COUNTY	TOTAL SHEETS	SHEET NO.
72	D7 BRIDGE REPAIRS 2026-3	MACON	108	94
CONTRACT NO. 74D08				
ILLINOIS FED. AID PROJECT				

(Sheet 1 of 2)

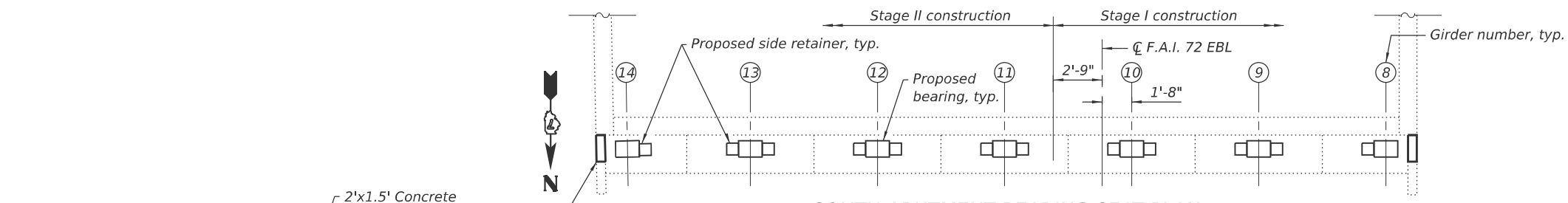

SOUTH ABUTMENT BEARING SEAT PLAN

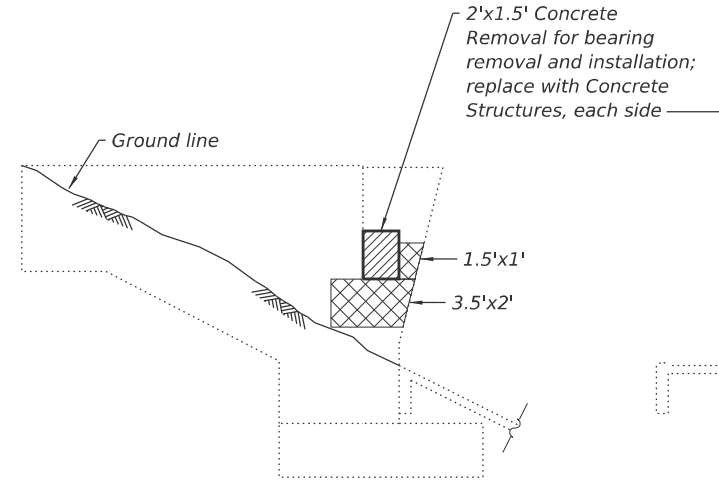

SOUTHEAST WINGWALL

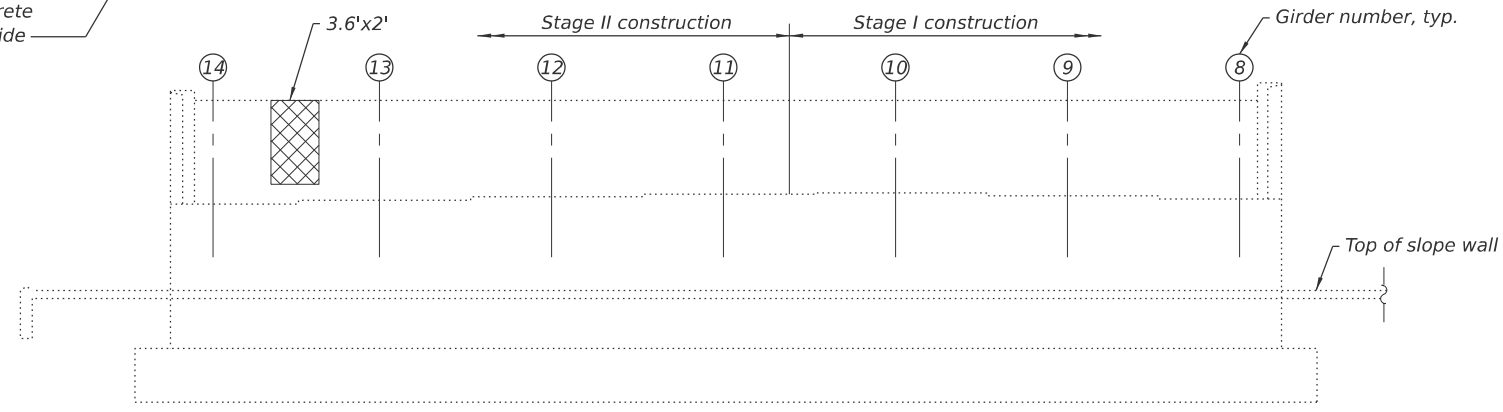

SOUTH ABUTMENT ELEVATION

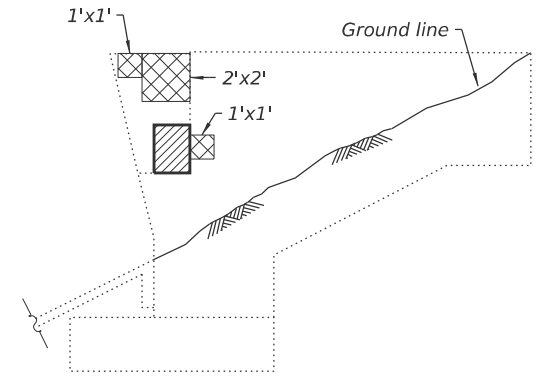

SOUTHWEST WINGWALL

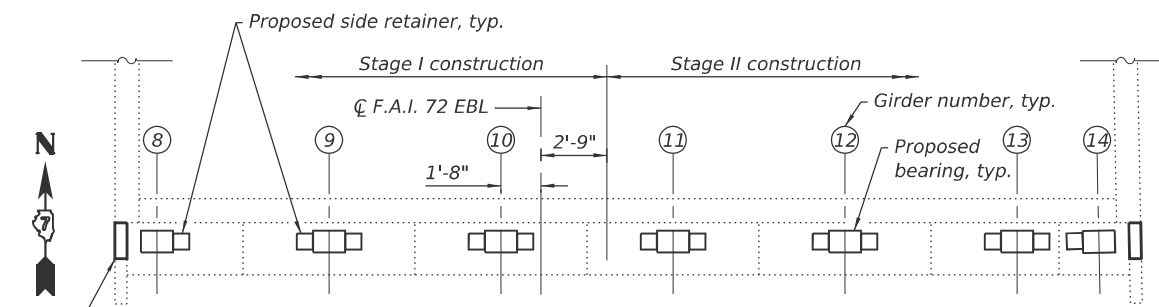

NORTH ABUTMENT BEARING SEAT PLAN

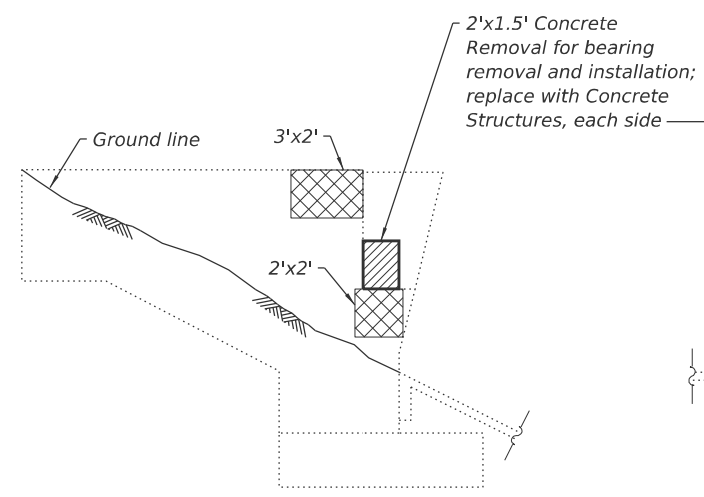

NORTHWEST WINGWALL

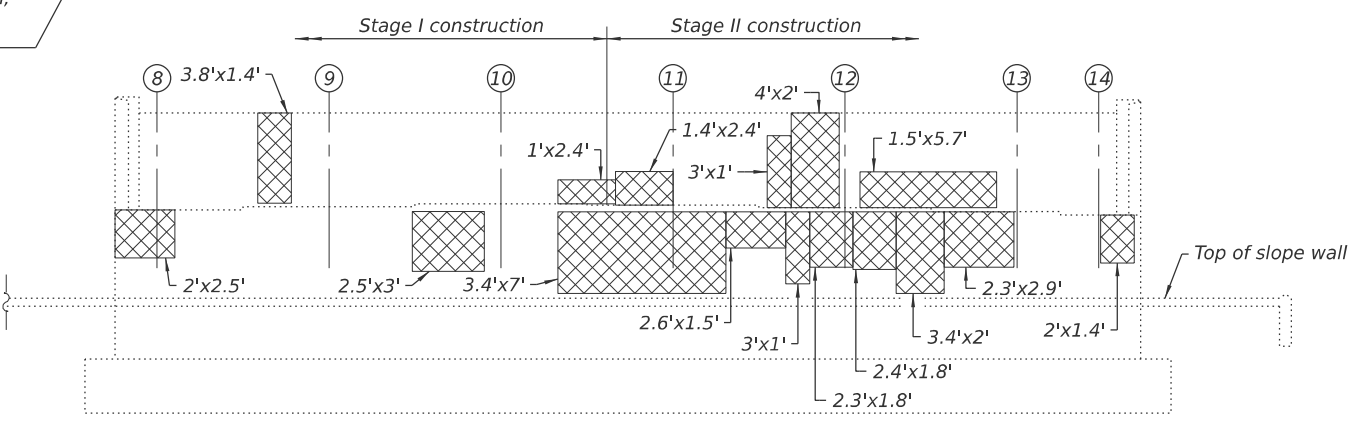

NORTH ABUTMENT ELEVATION

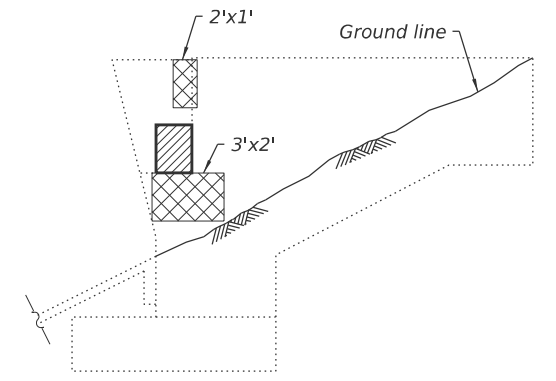

NORTHEAST WINGWALL

Note:
1. Abutment repairs shall be staged according to the same dimensions and locations as shown for the superstructure.

LEGEND

Structural Repair of Concrete (Depth Equal to or Less Than 5 Inches)

SN 058-0071 BILL OF MATERIAL

Item	Unit	Quantity
Structural Repair of Concrete (Depth Equal to or Less Than 5 Inches)	Sq. Ft.	138.3
Concrete Removal	Cu. Yd.	0.3
Concrete Structures	Cu. Yd.	0.3

(Sheet 2 of 2)

MODEL: Sheet FILE NAME: Y:\DOT11445-01_74D0874D08 DESIGN\CADD\SP SN 058-0071\1\Common Sheets\0580070-D774D08-23-AbutRepairs(EB).dgn



USER NAME = nhc
ESCA PROJECT NO. = 1445.01
PLOT SCALE = 0.2" / in.
PLOT DATE = 1/20/2026

DESIGNED - ELH 08/25
CHECKED - RDP 08/25
DRAWN - NHC 08/25
CHECKED - ELH 08/25

REVISED -
REVISED -
REVISED -
REVISED -

**STATE OF ILLINOIS
DEPARTMENT OF TRANSPORTATION**

**ABUTMENT REPAIRS
SN 058-0071 (EB)**

SHEET 23 OF 36 SHEETS

F.A.I. RTE.	SECTION	COUNTY	TOTAL SHEETS	SHEET NO.
72	D7 BRIDGE REPAIRS 2026-3	MACON	108	95
CONTRACT NO. 74D08				
ILLINOIS FED. AID PROJECT				

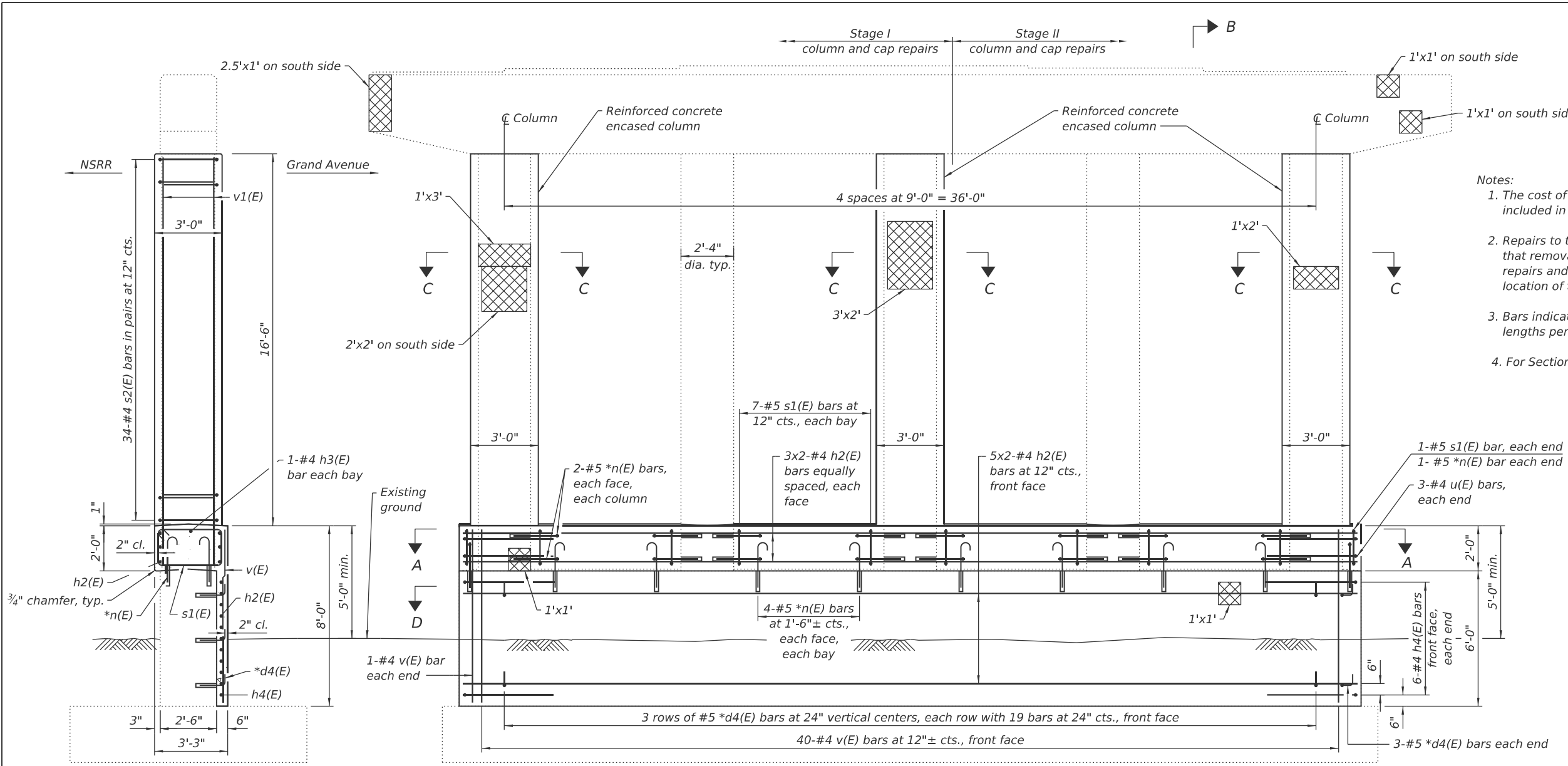

- Notes:
1. The cost of excavation and backfill required for pier repairs is included in Concrete Structures.
 2. Repairs to the pier cap and columns shall be staged as shown so that removal work is not performed under live traffic. Crashwall repairs and crashwall extension work are not restricted by the location of traffic.
 3. Bars indicated thus 5x2-#4 etc. indicates 5 lines of bars with 2 lengths per line.
 4. For Section C-C, View D see Sheet 26 of 36.

SECTION B-B

ELEVATION
(Looking South)

*Epoxy grout n(E) and d4(E) bars in 9" min. holes according to Article 584 of the Standard Specifications. Adjust locations to clear existing reinforcement. Cost is included in Reinforcement Bars, Epoxy Coated.

MINIMUM BAR LAP
#4 bar = 2'-0"

LEGEND

Structural Repair of Concrete (Depth Equal to or Less Than 5 Inches)

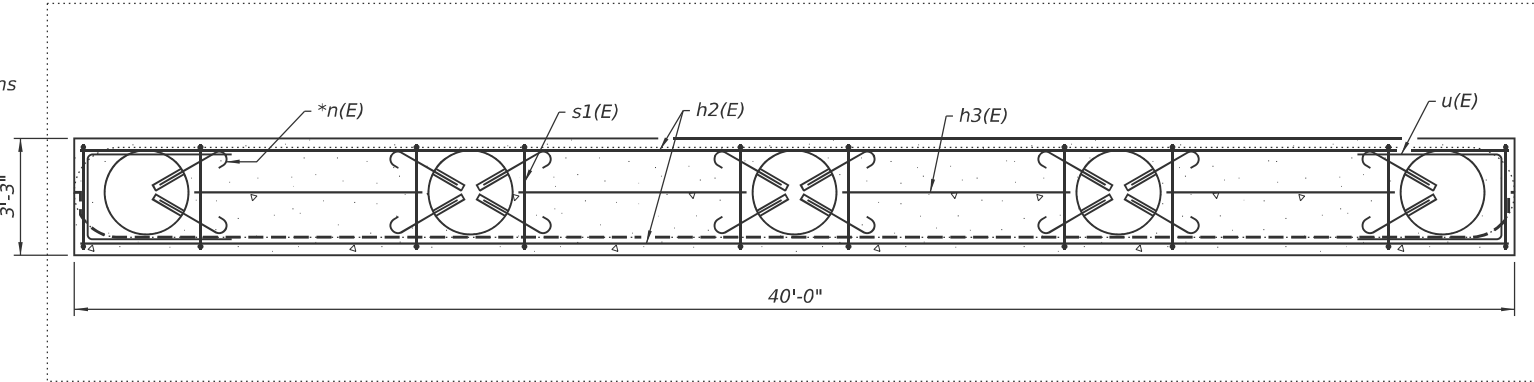

SECTION A-A

SN 058-0070 BILL OF MATERIAL

Bar	No.	Size	Length	Shape	
d4(E)	63	#5	1'-7"	□	
h2(E)	22	#4	21'-0"	—	
h3(E)	4	#4	6'-4"	—	
h4(E)	12	#4	4'-8"	—	
n(E)	66	#5	2'-7"	—	
s1(E)	30	#5	9'-11"	□	
s2(E)	102	#4	7'-7"	□	
u(E)	6	#4	10'-10"	□	
v(E)	42	#4	7'-8"	—	
v1(E)	36	#4	18'-1"	—	
Concrete Structures				Cu. Yd.	21.4
Reinforcement Bars, Epoxy Coated				Pound	2,170
Structural Repair of Concrete (Depth Equal to or Less Than 5 Inches)				Sq. Ft.	21.5

(Sheet 1 of 3)

MODEL: Sheet
FILE NAME: Y:\DOT\1445-01_74D08\74D08 DESIGN\CADD\SP SN 058-0070-0071\Common Sheets\0580070-0071-PierRepairs(WB).dgn



USER NAME = nhc
ESCA PROJECT NO. = 1445.01
PLOT SCALE = 0:2" = 1" / in.
PLOT DATE = 1/20/2026

DESIGNED - ELH 08/25
CHECKED - RDP 08/25
DRAWN - NHC 08/25
CHECKED - ELH 08/25

REVISED -
REVISED -
REVISED -
REVISED -

**STATE OF ILLINOIS
DEPARTMENT OF TRANSPORTATION**

**PIER REPAIRS
SN 058-0070 (WB)**

SHEET 24 OF 36 SHEETS

F.A.I. RTE.	SECTION	COUNTY	TOTAL SHEETS	SHEET NO.
72	D7 BRIDGE REPAIRS 2026-3	MACON	108	96
CONTRACT NO. 74D08				
ILLINOIS FED. AID PROJECT				

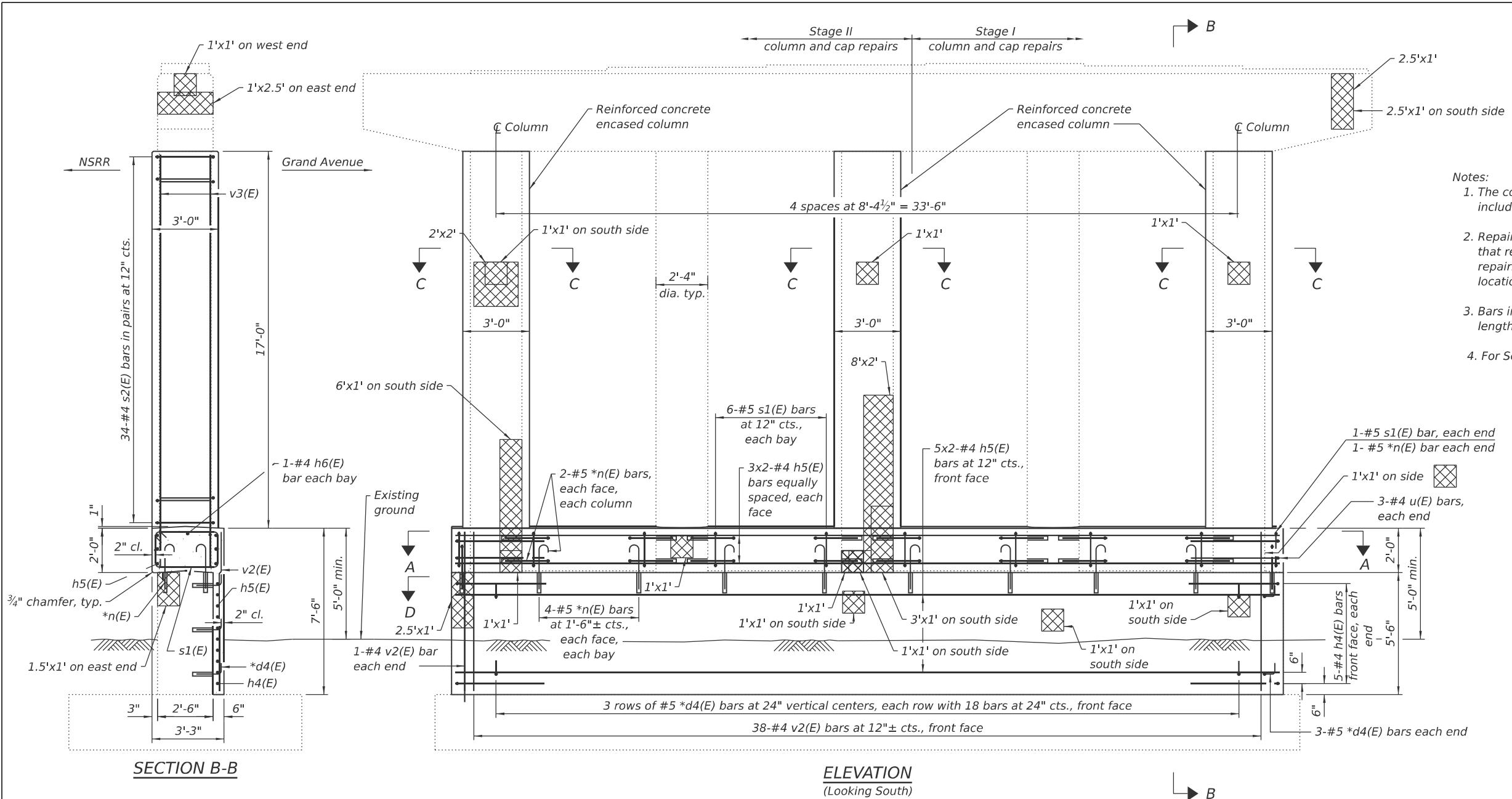

- Notes:
1. The cost of excavation and backfill required for pier repairs is included in Concrete Structures.
 2. Repairs to the pier cap and columns shall be staged as shown so that removal work is not performed under live traffic. Crashwall repairs and crashwall extension work are not restricted by the location of traffic.
 3. Bars indicated thus 5x2-#4 etc. indicates 5 lines of bars with 2 lengths per line.
 4. For Section C-C, View D see Sheet 26 of 36.

*Epoxy grout n(E) and d4(E) bars in 9" min. holes according to Article 584 of the Standard Specifications. Adjust locations to clear existing reinforcement. Cost is included in Reinforcement Bars, Epoxy Coated.

MINIMUM BAR LAP
#4 bar = 2'-0"

LEGEND

Structural Repair of Concrete (Depth Equal to or Less Than 5 Inches)

SN 058-0071 BILL OF MATERIAL

Bar	No.	Size	Length	Shape	
d4(E)	60	#5	1'-7"		
h4(E)	10	#4	4'-8"		
h5(E)	22	#4	19'-9"		
h6(E)	4	#4	5'-9"		
n(E)	66	#5	2'-7"		
s1(E)	26	#5	9'-11"		
s2(E)	102	#4	7'-7"		
u(E)	6	#4	10'-10"		
v2(E)	40	#4	7'-2"		
v3(E)	36	#4	18'-7"		
Concrete Structures				Cu. Yd.	21.3
Reinforcement Bars, Epoxy Coated				Pound	2,090
Structural Repair of Concrete (Depth Equal to or Less Than 5 Inches)				Sq. Ft.	52.5

(Sheet 2 of 3)

MODEL: Sheet
FILE NAME: Y:\DOT11445-01_74D08\74D08 DESIGN\CADD\SP SN 058-0070-0071\Common Sheets\0580070-0071-4D08-25-PierRepairs(EB).dgn



USER NAME = nhc
ESCA PROJECT NO. = 1445.01
PLOT SCALE = 0:2" = 1" / in.
PLOT DATE = 1/20/2026

DESIGNED - ELH 08/25
CHECKED - RDP 08/25
DRAWN - NHC 08/25
CHECKED - ELH 08/25

REVISED -
REVISED -
REVISED -
REVISED -

**STATE OF ILLINOIS
DEPARTMENT OF TRANSPORTATION**

**PIER REPAIRS
SN 058-0071 (EB)**

SHEET 25 OF 36 SHEETS

F.A.I. RTE.	SECTION	COUNTY	TOTAL SHEETS	SHEET NO.
72	D7 BRIDGE REPAIRS 2026-3	MACON	108	97
CONTRACT NO. 74D08				
ILLINOIS FED. AID PROJECT				

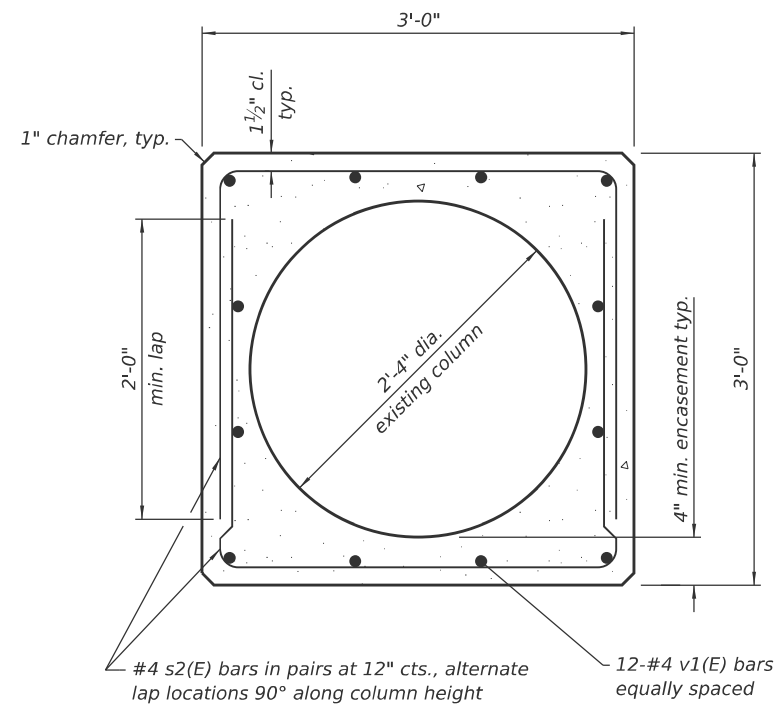

SECTION C-C

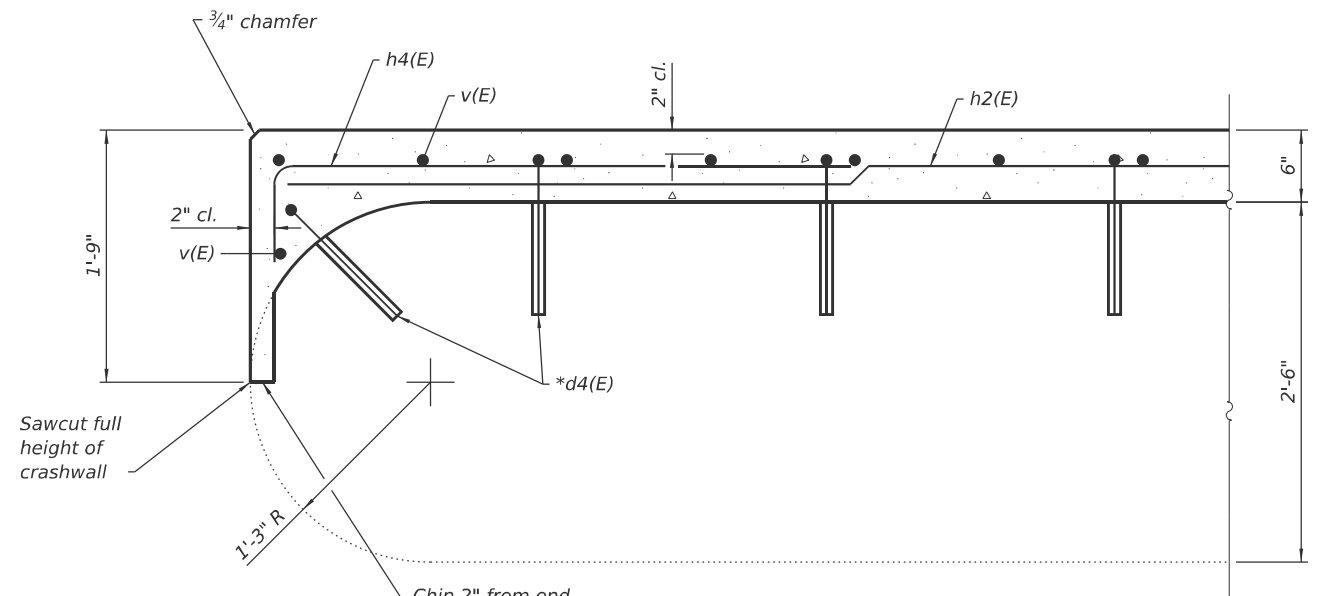

VIEW D
(Each end of pier)

*Epoxy grout n(E) and d4(E) bars in 9" min. holes according to Article 584 of the Standard Specifications. Adjust locations to clear existing reinforcement. Cost is included in Reinforcement Bars, Epoxy Coated.

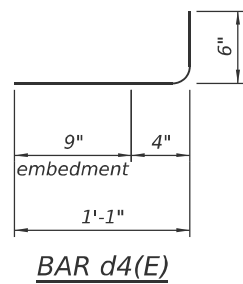

BAR d4(E)

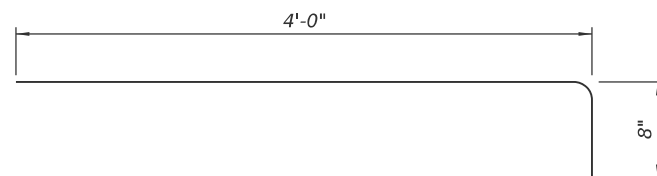

BAR h4(E)

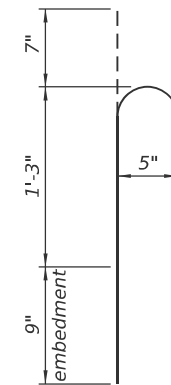

BAR n(E)

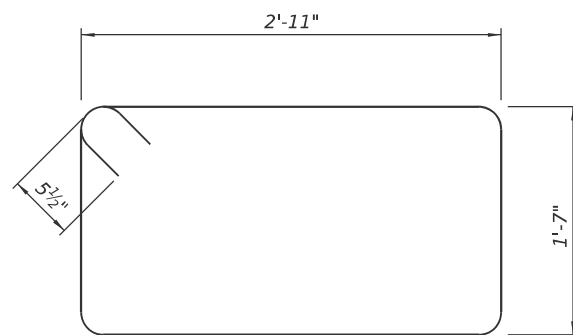

BAR s1(E)

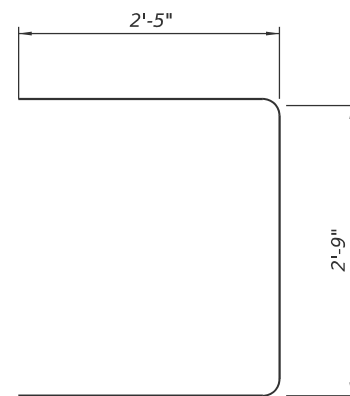

BAR s2(E)

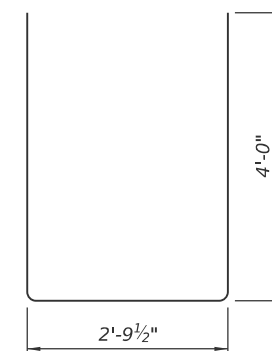

BAR u(E)

(Sheet 3 of 3)

MODEL: Sheet
FILE NAME: Y:\DOT\1445-01_74D08\74D08 DESIGN\CADD\SP SN 058-0070-0071\Common Sheets\0580070-0071-4D08-26-PierDils.dgn



USER NAME = nhc	DESIGNED - ELH 08/25	REVISED -
ESCA PROJECT NO. = 1445.01	CHECKED - RDP 08/25	REVISED -
PLOT SCALE = 0.2 "/in.	DRAWN - NHC 08/25	REVISED -
PLOT DATE = 1/20/2026	CHECKED - ELH 08/25	REVISED -

**STATE OF ILLINOIS
DEPARTMENT OF TRANSPORTATION**

**PIER REPAIRS
SN 058-0070 (WB) & SN 058-0071 (EB)**

SHEET 26 OF 36 SHEETS

F.A.I. RTE.	SECTION	COUNTY	TOTAL SHEETS	SHEET NO.
72	D7 BRIDGE REPAIRS 2026-3	MACON	108	98
CONTRACT NO. 74D08				
ILLINOIS FED. AID PROJECT				

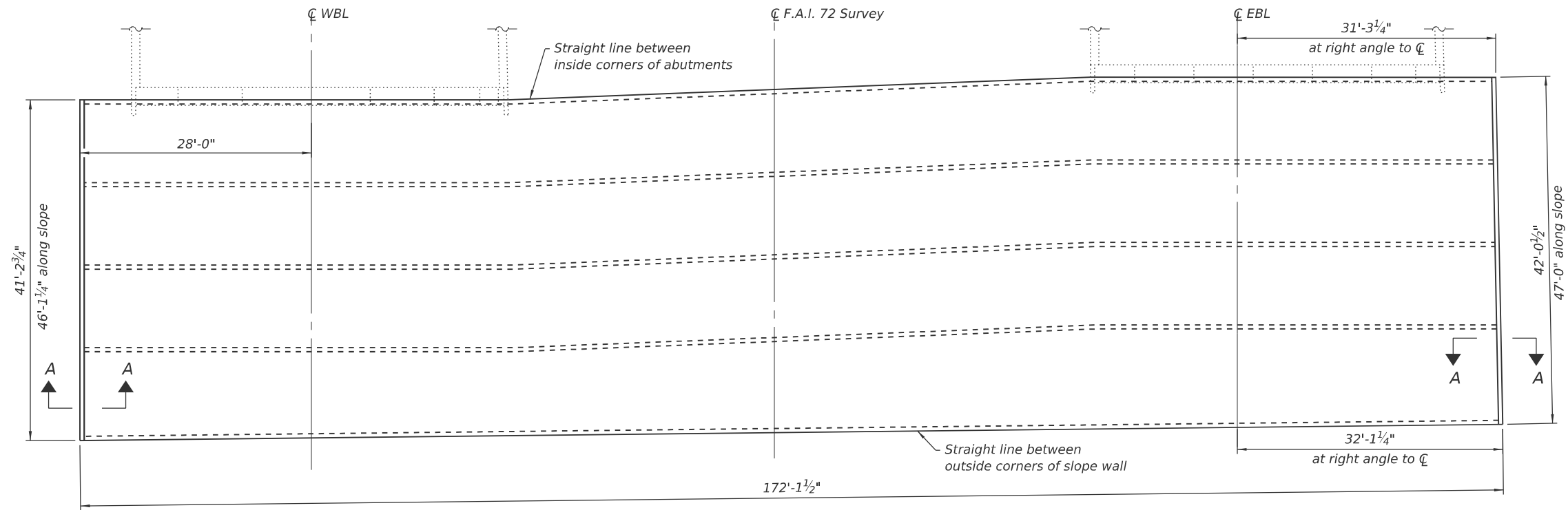

PLAN

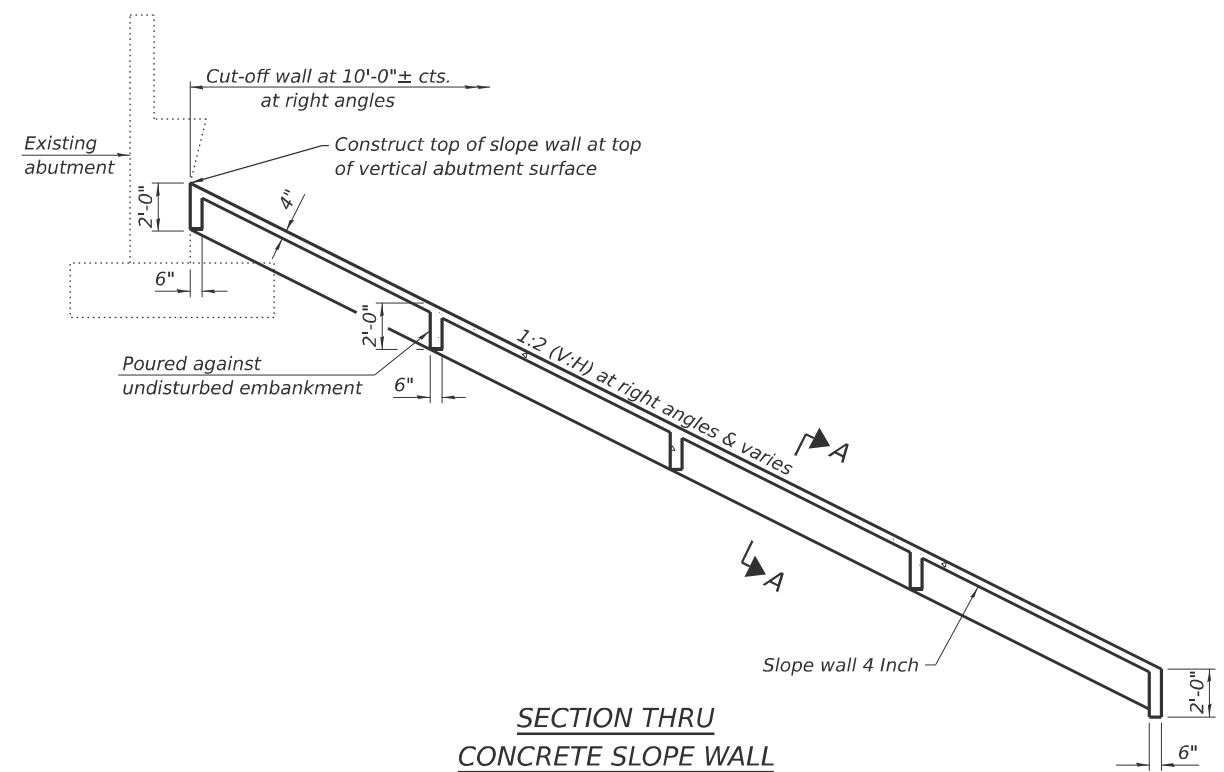

SECTION THRU CONCRETE SLOPE WALL

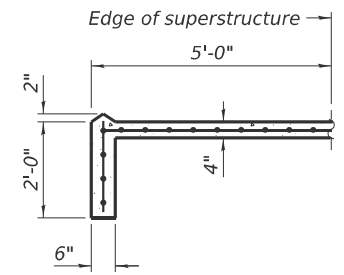

SECTION A-A

Notes:

1. The entire concrete slope wall shall be removed and paid for as Slope Wall Removal.
2. Unsuitable embankment material shall be removed as directed by the Engineer. The removal will be paid for as Removal and Disposal of Unsuitable Materials. The embankment shall be reconstructed with Subbase Granular Material, Type B. The Subbase Granular Material shall be gradation CA6 unless otherwise specified by the Engineer.
3. Slope wall shall be reinforced with welded wire fabric, 6 in. x 6 in.-W4.0 x W4.0, weighing 58 lbs. per 100 sq. ft.

SN 058-0070 & SN 058-0071
BILL OF MATERIAL

Item	Unit	Quantity
Slope Wall Removal	Sq. Yd.	896
Protective Coat	Sq. Yd.	888
Slope Wall 4 Inch	Sq. Yd.	888
Subbase Granular Material, Type B	Ton	200
Removal and Disposal of Unsuitable Material	Cu. Yd.	40

MODEL: Sheet
FILE NAME: Y:\DOT\1445-01_74D08\74D08 DESIGN\CADD\SP SN 058-0070-0071\Common Sheets\0580070-0071-NorthSlopeWall.dgn



USER NAME = nhc
ESCA PROJECT NO. = 1445.01
PLOT SCALE = 0.2" = 1' / in.
PLOT DATE = 1/20/2026

DESIGNED - ELH 08/25
CHECKED - RDP 08/25
DRAWN - NHC 08/25
CHECKED - ELH 08/25

REVISED -
REVISED -
REVISED -
REVISED -

STATE OF ILLINOIS
DEPARTMENT OF TRANSPORTATION

NORTH SLOPE WALL
SN 058-0070 (WB) & SN 058-0071 (EB)

SHEET 27 OF 36 SHEETS

F.A.I. RTE.	SECTION	COUNTY	TOTAL SHEETS	SHEET NO.
72	D7 BRIDGE REPAIRS 2026-3	MACON	108	99
CONTRACT NO. 74D08				
ILLINOIS FED. AID PROJECT				

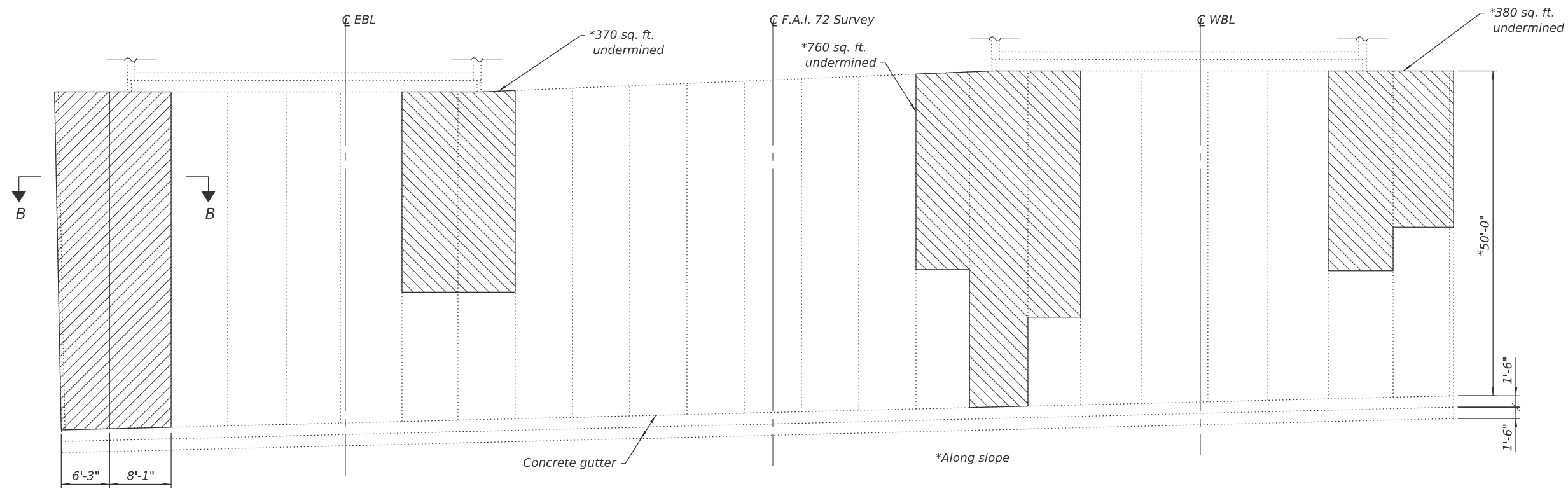

PLAN

- Notes:**
1. Prior to partial removal of slope wall, a $\frac{3}{4}$ " deep saw cut shall be made along all boundaries of the removal areas. Saw cuts will be included in the cost of Slope Wall Repair.
 2. Unsuitable embankment material shall be removed as directed by the Engineer. The removal will be paid for as Removal and Disposal of Unsuitable Materials. In these areas the embankment shall be reconstructed with Subbase Granular Material, Type B. The Subbase Granular Material shall be gradation CA6 unless otherwise specified by the Engineer.
 3. At locations where the concrete slope wall is still intact but has been undermined, Slope Wall Slurry Pumping shall be used to replace the base under the existing slope wall.
 4. Quantities and locations are approximated. Actual quantities and locations are to be determined in the field by the Engineer. This work is intended to repair only areas of severe deterioration. Some minor deteriorated areas may be left unrepaired.

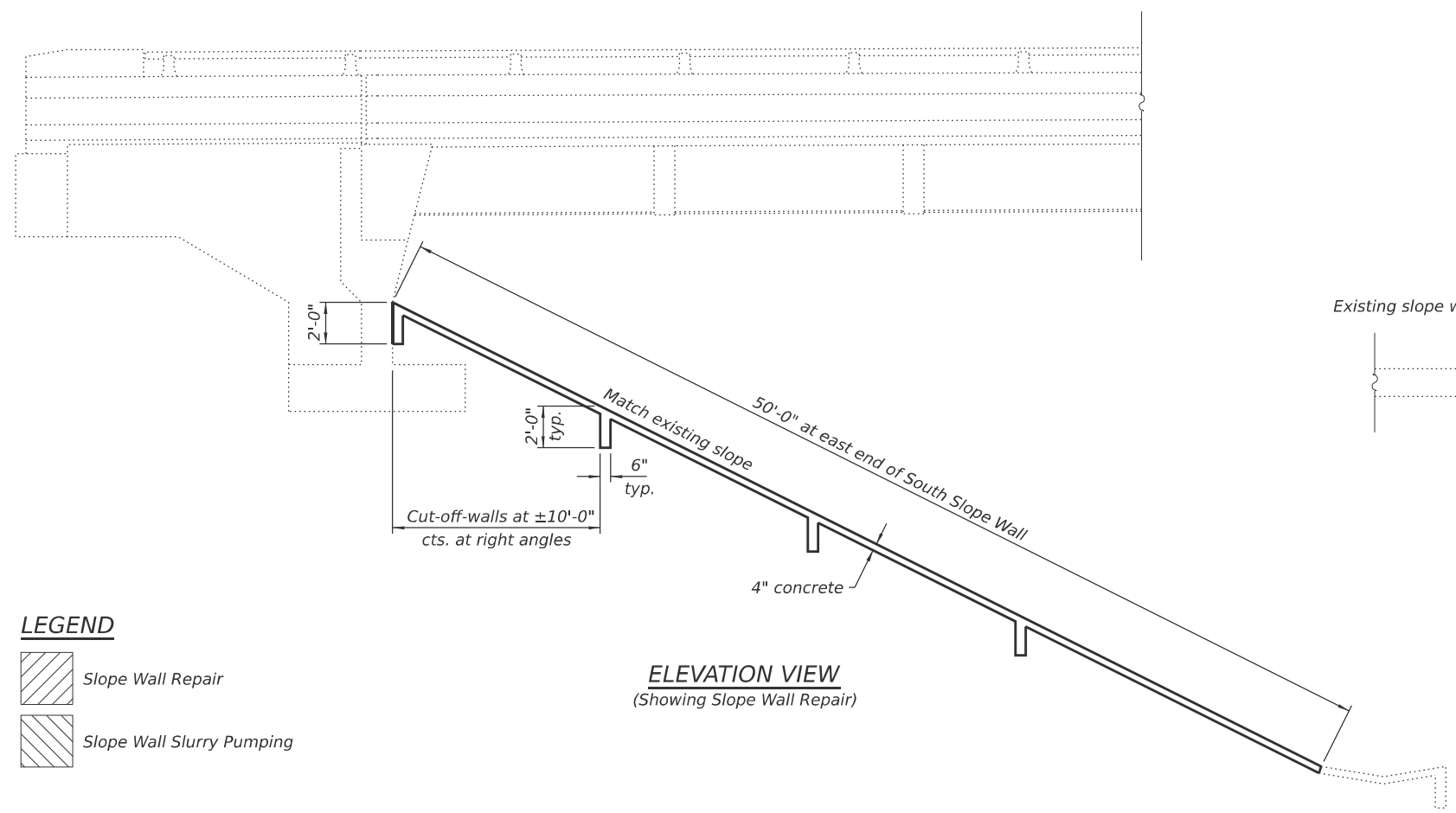

ELEVATION VIEW
(Showing Slope Wall Repair)

LEGEND

- Slope Wall Repair
- Slope Wall Slurry Pumping

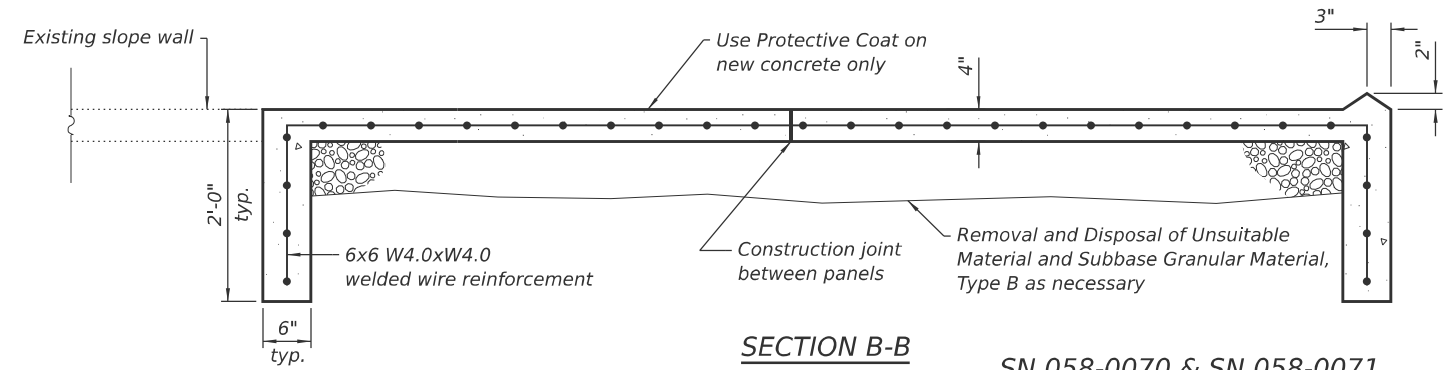

SECTION B-B

SN 058-0070 & SN 058-0071
BILL OF MATERIAL

Item	Unit	Quantity
Slope Wall Repair	Sq. Yd.	80
Slope Wall Slurry Pumping	Cu. Yd.	50
Protective Coat	Sq. Yd.	80
Subbase Granular Material, Type B	Ton	55
Removal and Disposal of Unsuitable Material	Cu. Yd.	15

MODEL: Sheet
FILE NAME: Y:\DOT1445-01_74D0874D08 DESIGN\CADD\SP SN 058-0070-071\1\Common Sheets\0580070-D774D08-28-SlopeWallRepair.dgn



USER NAME = nhc
ESCA PROJECT NO. = 1445.01
PLOT SCALE = 0.2" / in.
PLOT DATE = 1/20/2026

DESIGNED - ELH 08/25
CHECKED - RDP 08/25
DRAWN - NHC 08/25
CHECKED - ELH 08/25

REVISED -
REVISED -
REVISED -
REVISED -

STATE OF ILLINOIS
DEPARTMENT OF TRANSPORTATION

SOUTH SLOPE WALL REPAIRS
SN 058-0070 (WB) & SN 058-0071 (EB)

SHEET 28 OF 36 SHEETS

F.A.I. RTE.	SECTION	COUNTY	TOTAL SHEETS	SHEET NO.
72	D7 BRIDGE REPAIRS 2026-3	MACON	108	100
CONTRACT NO. 74D08				
ILLINOIS FED. AID PROJECT				

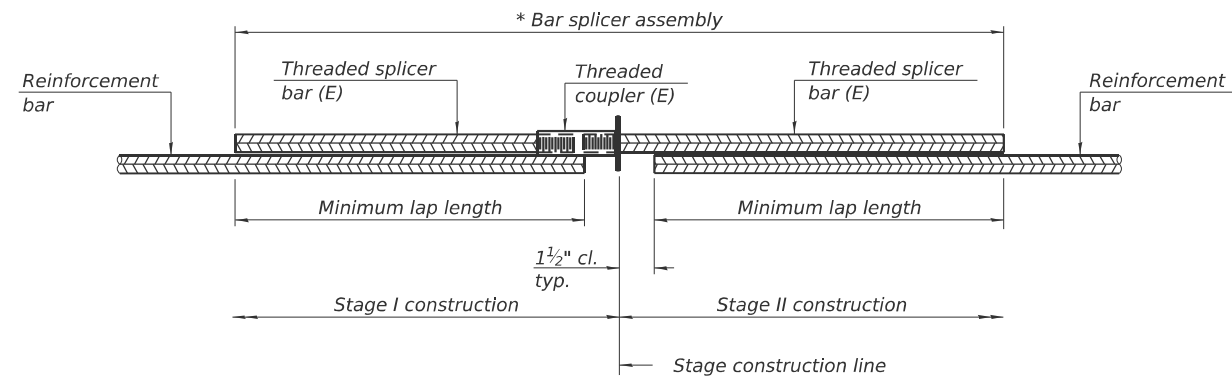

STANDARD BAR SPLICER ASSEMBLY PLAN
 Only bar splicer assemblies as presented on the approved QPL list may be used.

Threaded splicer bar length = min. lap length + 1 1/2" + thread length

* Epoxy not required on Bar Splicer Assembly components used in conjunction with black bars.

Location	Bar size	No. assemblies required	Minimum lap length
SN 058-0070 Spans 1 & 4 slabs	#5	4	3'-5"
SN 058-0070 Spans 2 & 3 deck	#6	16	5'-3"
SN 058-0071 Spans 1 & 4 slabs	#5	4	3'-5"
SN 058-0071 Spans 2 & 3 deck	#6	16	5'-3"

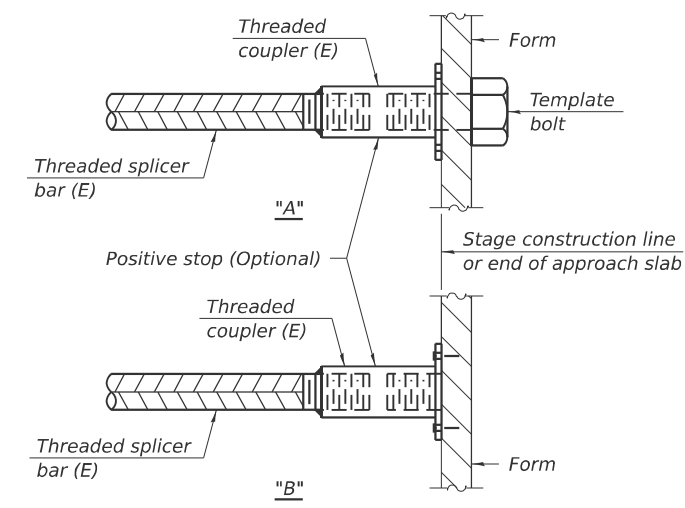

INSTALLATION AND SETTING METHODS

"A" : Set bar splicer assembly by means of a template bolt.
 "B" : Set bar splicer assembly by nailing to wood forms or cementing to steel forms.
 (E) : Indicates epoxy coating.

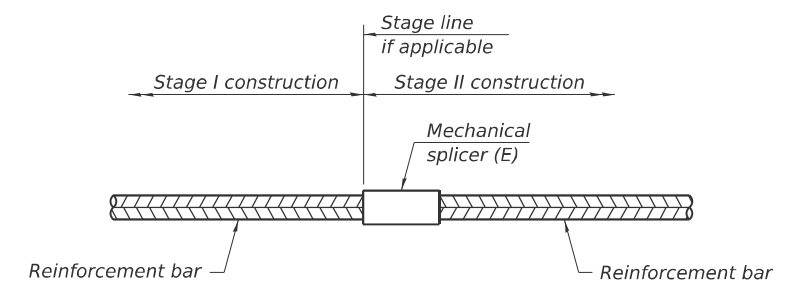

STANDARD MECHANICAL SPLICER

Location	Bar size	No. assemblies required
NA		

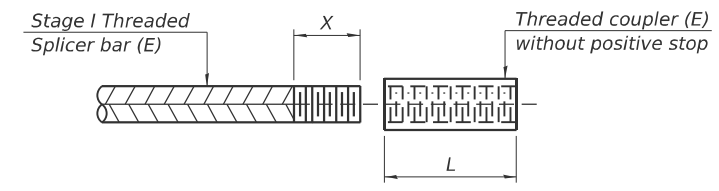

THREADING OF ASSEMBLIES

The threaded length "X" shall be no more than L/2. The bar should be tightened until 0-1 thread(s) is/are exposed.

Notes:
 Splicer bars shall be deformed with threaded ends and have a minimum 60 ksi yield strength.
 All reinforcement shall be lapped and tied to the splicer bars.
 Bar splicer assemblies shall be epoxy coated according to the requirements for reinforcement bars. See Section 508 of the Standard Specifications.
 See approved list of bar splicer assemblies and mechanical splicers for alternatives.

MODEL: Sheet
 FILE NAME: Y:\DOT11445-01_Z4D08\74D08 DESIGN\CADD\SP SN 058-0070-0071\Common Sheets\0580070-0071-BarSplice.dgn

BSD-1

4-4-2025



USER NAME = nhc	DESIGNED - ELH 07/25	REVISED -
ESCA PROJECT NO. = 1445.01	CHECKED - RDP 07/25	REVISED -
PLOT SCALE = 0.2" / in.	DRAWN - NHC 07/25	REVISED -
PLOT DATE = 1/20/2026	CHECKED - ELH 07/25	REVISED -

STATE OF ILLINOIS
 DEPARTMENT OF TRANSPORTATION

BAR SPLICER ASSEMBLY AND MECHANICAL SPLICER DETAILS
 SN 058-0070 (WB) & SN 058-0071 (EB)

SHEET 29 OF 36 SHEETS

F.A.I. RTE.	SECTION	COUNTY	TOTAL SHEETS	SHEET NO.
72	D7 BRIDGE REPAIRS 2026-3	MACON	108	101
CONTRACT NO. 74D08				
ILLINOIS FED. AID PROJECT				

REMOVAL DETAIL

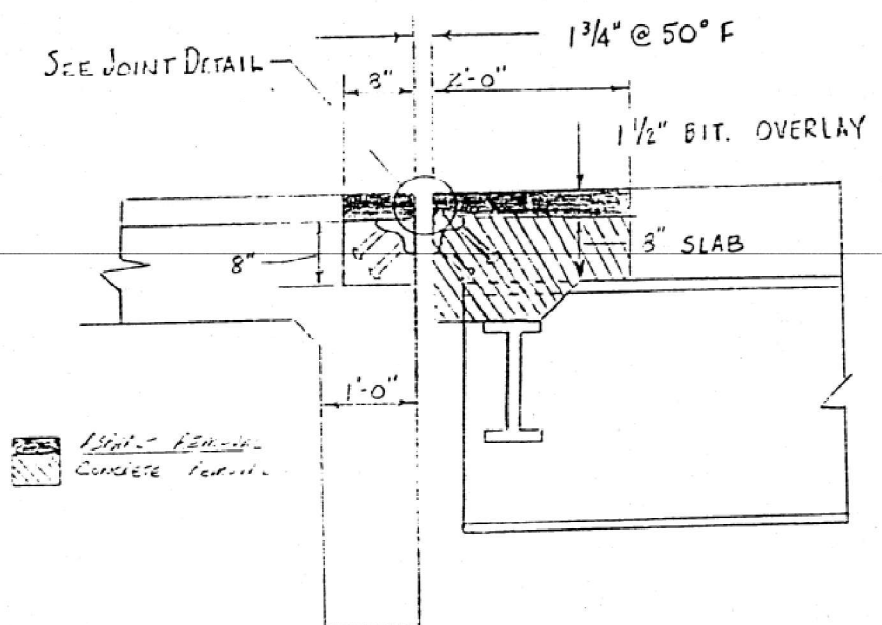

JOINT DETAIL

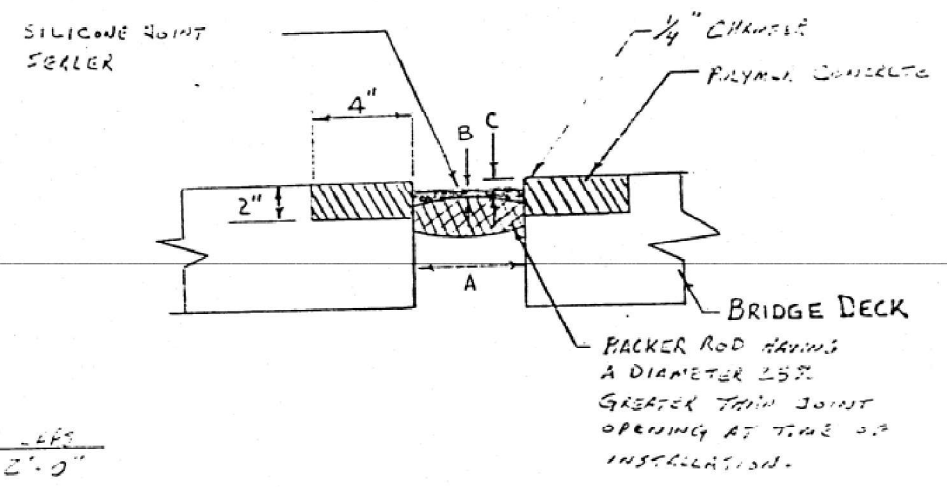

MIN. BAR LEGS
6 - 2'-0"

	A	B	C
	JOINT OPENING	SEALANT THICKNESS	SEALANT RECESS
NORTH ABUTMENT	2"	5/8"	3/4"
SOUTH ABUTMENT	2"	5/8"	3/4"

REPLACEMENT DETAIL

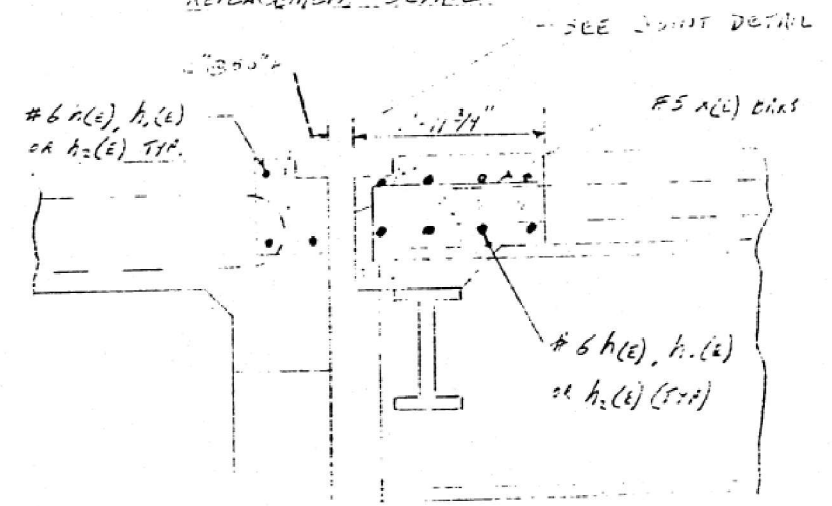

NOTE: NORTH AND SOUTH JOINTS 2" AT 50°F. ALL MATERIALS, INSTALLATION PROCEDURES AND DIMENSIONS WILL CONFORM TO SPECIAL PROVISIONS AND MANUFACTURERS RECOMMENDATIONS.

* NOTE: EXISTING REINFORCEMENT BARS TO BE REUSED, SHALL BE CLEANED AND STRAIGHTENED PRIOR TO INSTALLATION IN NEW CONCRETE.

(Sheet 2 of 7)

MODEL: Sheet
FILE NAME: Y:\DOT\1445-01_74D08\74D08 DESIGN\CADD\SP SN 058-0070-0071\COMMON SHEETS\0580070-D774D08-31-ExpPlan.dgn



USER NAME = rnhc	DESIGNED - ELH 07/25	REVISED -
ESCA PROJECT NO. = 1445.01	CHECKED - RDP 07/25	REVISED -
PLOT SCALE = 0.2" = 1' / in.	DRAWN - NHC 07/25	REVISED -
PLOT DATE = 1/20/2026	CHECKED - ELH 07/25	REVISED -

STATE OF ILLINOIS
DEPARTMENT OF TRANSPORTATION

EXISTING BRIDGE PLANS - FOR INFORMATION ONLY
SN 058-0070 (WB)

SHEET 31 OF 36 SHEETS

F.A.I. RTE.	SECTION	COUNTY	TOTAL SHEETS	SHEET NO.
72	D7 BRIDGE REPAIRS 2026-3	MACON	108	103
CONTRACT NO. 74D08				
ILLINOIS FED. AID PROJECT				

ROUTE NO.	SECTION	COUNTY	TOTAL SHEETS	SHEET NO.
FRI-72	58-62WB	MACON	49	10
FED. ROAD DIST. NO.		ILLINOIS	PROJECT	

BENCH MARK: #10 Lag Screw in Tele. Pole
175' E. Sta. 534+95 FRI-72 Elev. 687.04
EXISTING STRUCTURE: None

DESIGN LOADINGS

Live Load HS20-44 & Alternate ARSHO 1973 Specs
Road Load includes 2 1/2' (30' ft.) of Roadway for
Future Wearing Surface

DESIGN STRESSES

- f_c = 1,400 P.S.I. Substr. Curb, Parapet & App. Slabs
- f_c = 1,000 P.S.I. Superstructure Slab
- f_c = 75 P.S.I. Footings
- f_s = 20,000 P.S.I. Reinforcing Steel
- f_s = 20,000 P.S.I. Structural Steel
- n = 10

LIVE LOAD DEFLECTION

1/1200 for composite Construction

GENERAL NOTES

- All reinforcement bars shall be lapped 24 diameters unless otherwise shown.
- Fasteners shall be high strength bolts. Bolts 3/4": open holes 13/16", unless otherwise noted.
- Calculated weight of Structural Steel = 556,487 Lbs.
- The basic lead silico chromate paint system shall be used for shop and field painting of Structural Steel.
- Field welding of construction accessories will not be permitted to the bottom flange of girders nor to the top flange for a distance equal to one-fourth the span length each way from the pier supports. Field welding in other areas will be permitted only when approved by the Engineer.
- Anchor bolts shall be set before bolting diaphragms over supports.
- Slope wall shall be reinforced with welded wire fabric 6"x6" mesh, weighing 58 lbs. per 100 sq.ft.
- The Contractor shall drive 6 Concrete test piles in permanent locations at Abutment #1 and #2 and Pier in the east and west bound structures as directed by the Engineer before ordering the remainder of piles.
- Concrete piles of abutments shall be driven in holes prepared through the embankment in accordance with Article 513.09(c) of the Standard Specifications.
- Boring Data are included with the Contract Proposals.

- The Contractor shall make allowance for the deflection of forms, shrinkage and settlement of falsework, in addition to allowance for dead load deflection.
- The embankment configuration shown shall be the minimum embankment that must be constructed prior to construction of the abutments.
- The concrete rail section above the mandatory construction joint at the top of the slab shall be constructed of Class X Concrete, except the aggregates shall conform to the requirements of Handrail Concrete.
- For Waterproofing Membrane System see Special Provisions. Protective Coat shall not be applied to surfaces to which Waterproofing Membrane System is applied.
- For excavation, under embankment cones, and porous granular embankment see roadway plans.

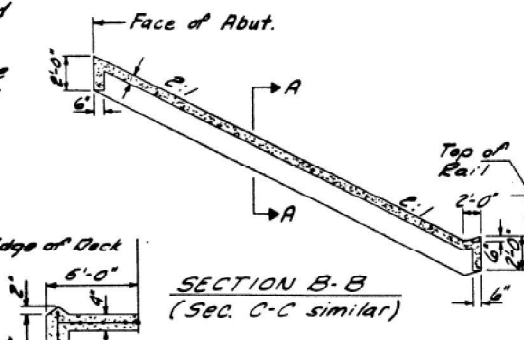
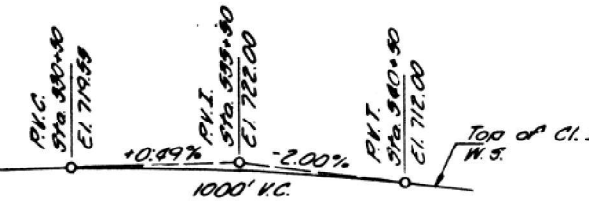

SECTION A-A
STA. 534+98.26
BUILT 197 BY
STATE OF ILLINOIS
FRI-72 SECTION 58-62WB
F.R. PROJ. I-16-72-1(43)
LOADING HS 20' 4" ALT.
LETTERING FOR NAME PLATES (E.B.)
(See Std. 2113)
Note: Sta. for W.B. Str. name plate shall be 534+95.50

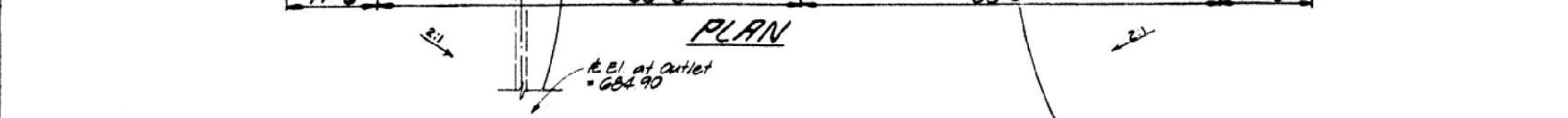
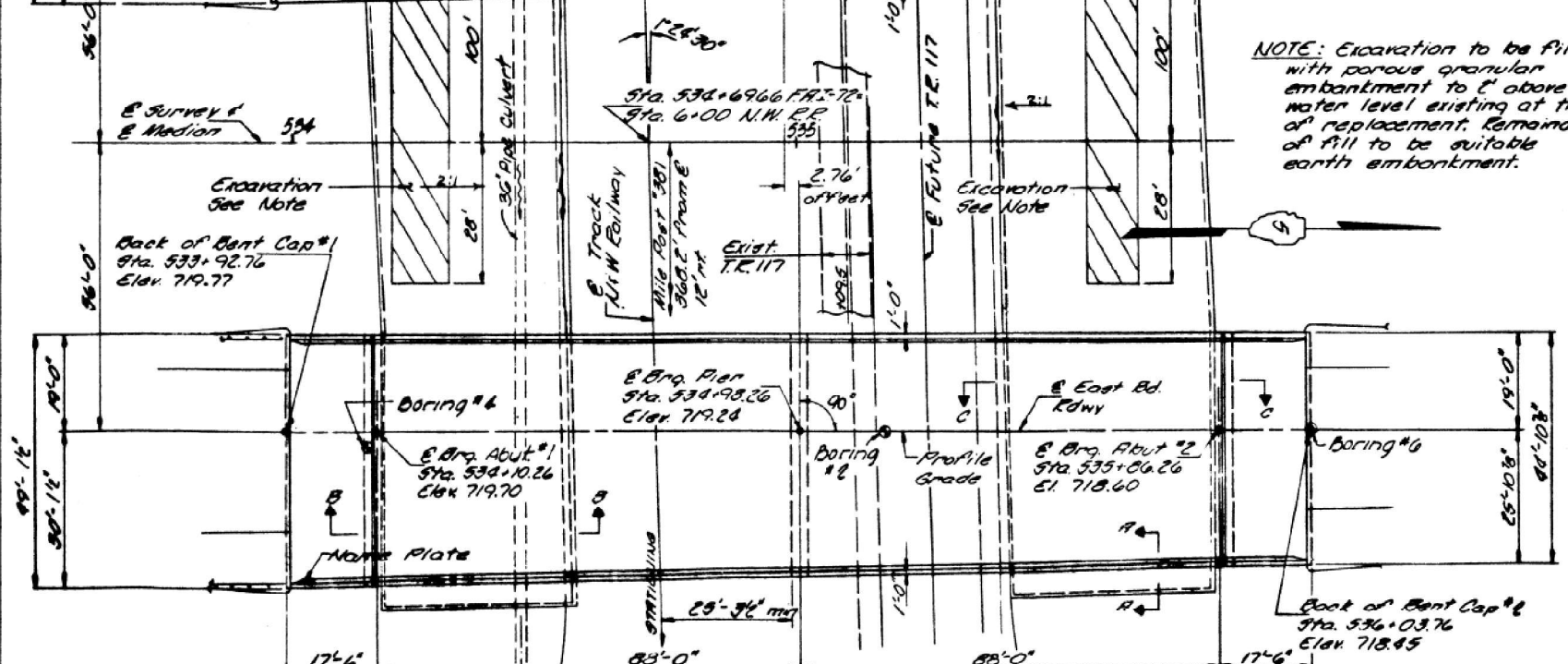
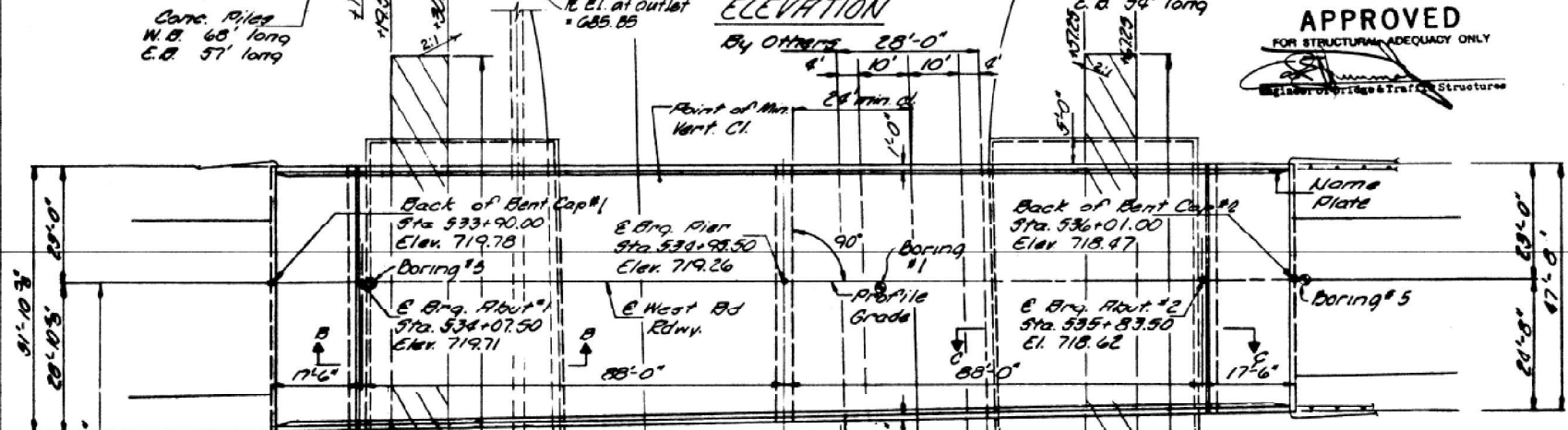
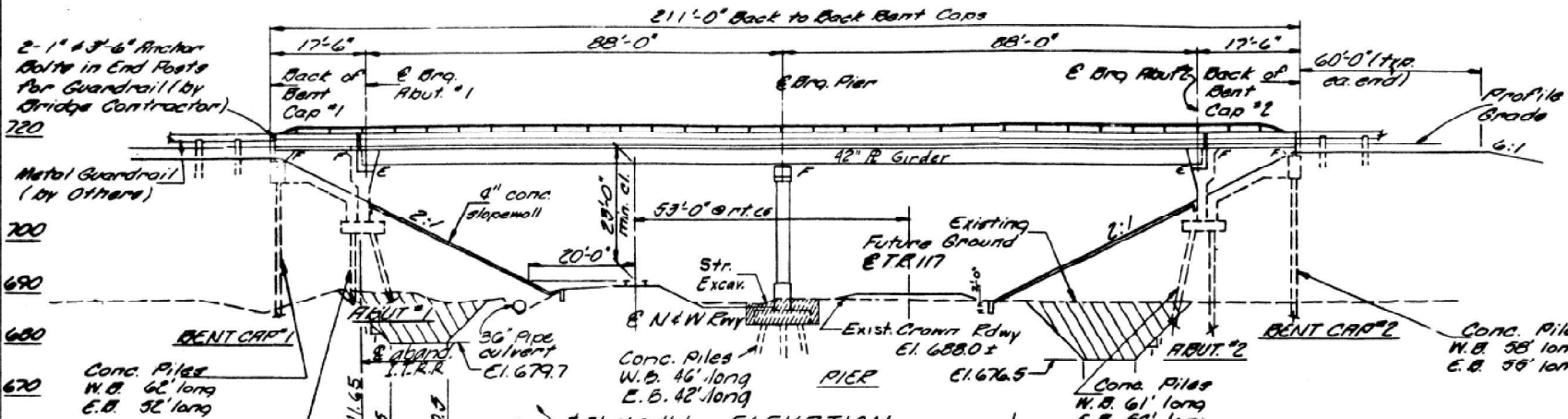
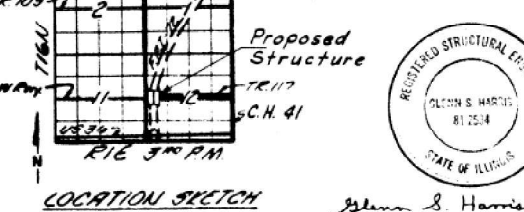

APPROVED
FOR STRUCTURAL ADEQUACY ONLY
[Signature]

NOTE: Excavation to be filled with porous granular embankment to 1' above water level existing at time of replacement. Remainder of fill to be suitable earth embankment.

TOTAL BILL OF MATERIAL

ITEM	UNIT	SUPERSTR	SUBSTR	TOTAL
Structure Excavation	Cu. Yds.		215	215
Class "X" Concrete	Cu. Yds.	654.2	525.5	1,180.7
Reinforcement Bars	Lbs.	157,950	67,530	225,480
Structural Steel	L.S.			
Aluminum Railing	Lin. Ft.	832		832
Name Plates	Each	2		2
Concrete Piles	Lin. Ft.		8,859	8,859
Test Piles (Concrete)	Each		6	6
Slopewall 4"	Sq. Yds.		1,750	1,750
Stud Shear Connectors	Each	5,292		5,292
Preformed Joint Sealer (2 1/2")	Lin. Ft.	199		199
Protective Coat	Sq. Yds.	296		296
Waterproofing Membrane System	Sq. Yds.	2,171		2,171
Bituminous Concrete Surface Course, Class I	Tons	182		182
Sand Backfill	Cu. Yds.		610	610

GENERAL PLAN & ELEVATION

REVISIONS

NO.	DATE	INITIALS
1	9/78	GSH
2	11/78	GSH

STATE OF ILLINOIS
DEPARTMENT OF TRANSPORTATION
DIVISION OF HIGHWAY

FRI-72 OVER N.W. RAILWAY
FRI-72 SEC. 58-62WB PROJECT
STA. 534+69.66 (FRI-72)

HOMER L. CHASTAIN & ASSOCIATES
CONSULTING ENGINEERS
DECATUR, ILLINOIS

DRAWN BY: DATE
GSH 7-78
CHECKED BY: DATE
GSH 7-78
BOOK NUMBER
PROJECT NO.
CONTRACT NO. 74D08
SHEET NO.
10



USER NAME = nhc	DESIGNED - ELH 07/25	REVISED -
ESCA PROJECT NO. = 1445.01	CHECKED - RDP 07/25	REVISED -
PLOT SCALE = 0.2" = 1'	DRAWN - NHC 07/25	REVISED -
PLOT DATE = 1/20/2026	CHECKED - ELH 07/25	REVISED -

STATE OF ILLINOIS
DEPARTMENT OF TRANSPORTATION

EXISTING BRIDGE PLANS - FOR INFORMATION ONLY
SN 058-0070 (WB) & SN 058-0071 (EB)

F.A.I. RTE.	SECTION	COUNTY	TOTAL SHEETS	SHEET NO.
72	D7 BRIDGE REPAIRS 2026-3	MACON	108	104
CONTRACT NO. 74D08				
ILLINOIS FED. AID PROJECT				

MODEL: Sheet
FILE NAME: Y:\DOT\1445-01_74D08\74D08 DESIGN\CADD\SP SN 058-0070-0071\Common Sheets\0580070-0071\008-32-ExpPlan.dgn
1/20/2026 1:56:00 PM

ROUTE NO.	SECTION	COUNTY	TOTAL SHEETS	SHEET NO.
FRI-72	58-621MB	MACON	49	21
FED. ROAD DIST. NO.	ILLINOIS	PROJECT		

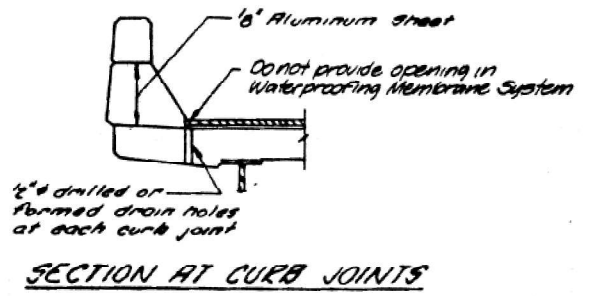
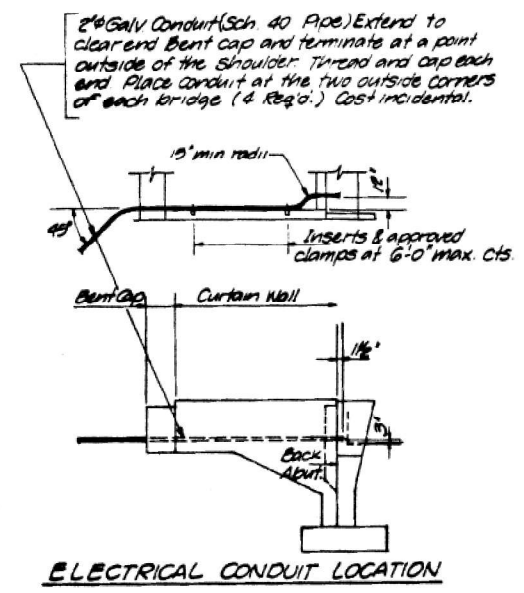

PREFORMED JOINT SEALER (2'x2')

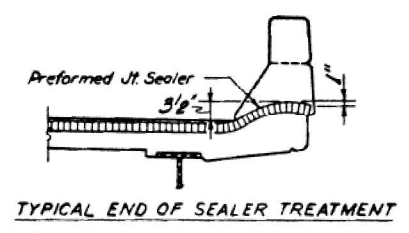
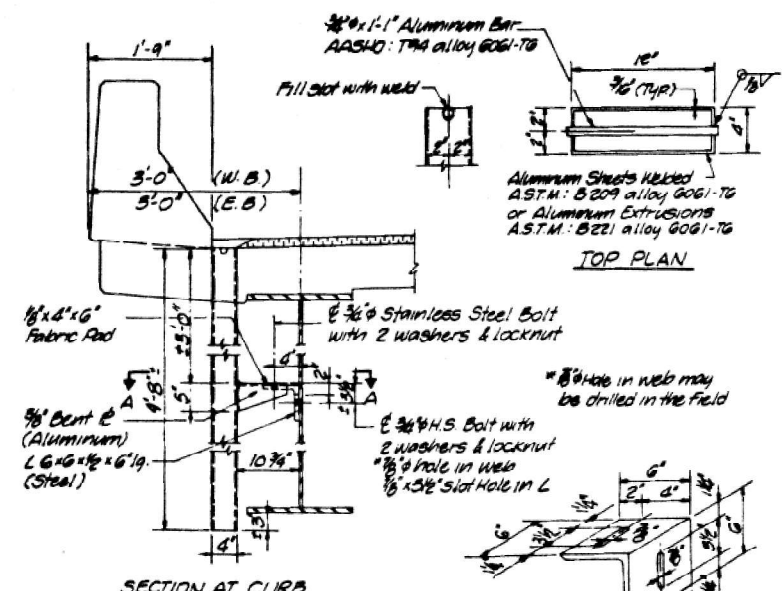
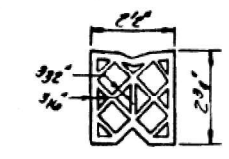

Location	**	***	****
Abut. #1 E.B.	45'-3"	45'-3"	46
Abut. #2 E.B.	41'-8 1/2"	41'-8 1/2"	42
Abut. #1 W.B.	48'-0 1/8"	48'-0 1/8"	48
Abut. #2 W.B.	44'-5 1/2"	44'-5 1/2"	45

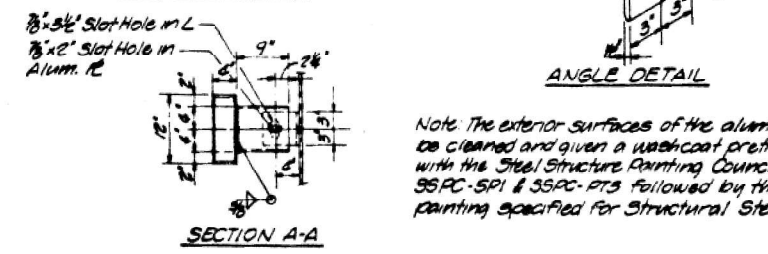
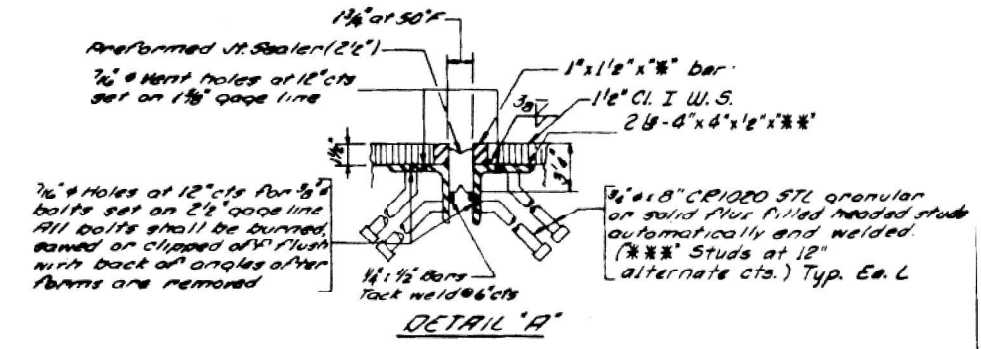

Note: The exterior surfaces of the aluminum drains shall be cleaned and given a washcoat pretreatment in accordance with the Steel Structure Painting Council's Specification SSPC-SP1 & SSPC-PT5 followed by the basic lead chromate painting specified for structural steel.

DETAILS OF GIRDER DRAIN EXTENSION
(Cost of Drains incidental to Class X Concrete)

REVISIONS		DETAILS		DATE
NO.	DATE	BY	CHKD.	
1				JUL 10 1976
DRAWN BY DATE				
CHECKED BY DATE				
PROJECT NO.				20295
SHEET NO.				21

(Sheet 4 of 7)

MODEL: Sheet
FILE NAME: Y:\ID0711445-01_74D08174D08 DESIGN\CADD\SP SN 058-0070-0071\COMMON SHEETS\0580070-0071-4D08-33-EXP\Plan.dgn



USER NAME = nhc	DESIGNED - ELH 07/25	REVISED -
ESCA PROJECT NO. = 1445.01	CHECKED - RDP 07/25	REVISED -
PLOT SCALE = 0.2" = 1' / in.	DRAWN - NHC 07/25	REVISED -
PLOT DATE = 1/20/2026	CHECKED - ELH 07/25	REVISED -

STATE OF ILLINOIS
DEPARTMENT OF TRANSPORTATION

EXISTING BRIDGE PLANS - FOR INFORMATION ONLY
SN 058-0070 (WB) & SN 058-0071 (EB)

F.A.I. RTE.	SECTION	COUNTY	TOTAL SHEETS	SHEET NO.
72	D7 BRIDGE REPAIRS 2026-3	MACON	108	105
CONTRACT NO. 74D08				
ILLINOIS FED. AID PROJECT				

ROUTE NO.	SECTION	COUNTY	TOTAL SHEETS	SHEET NO.
FAI-72	58-62WB	MACON	99	22
FED. ROAD DIST. NO.	ILLINOIS PROJECT			

210'-0" (W. Rail) End to End of Parapet
210'-0 7/8" (E. Rail) End to End of Parapet

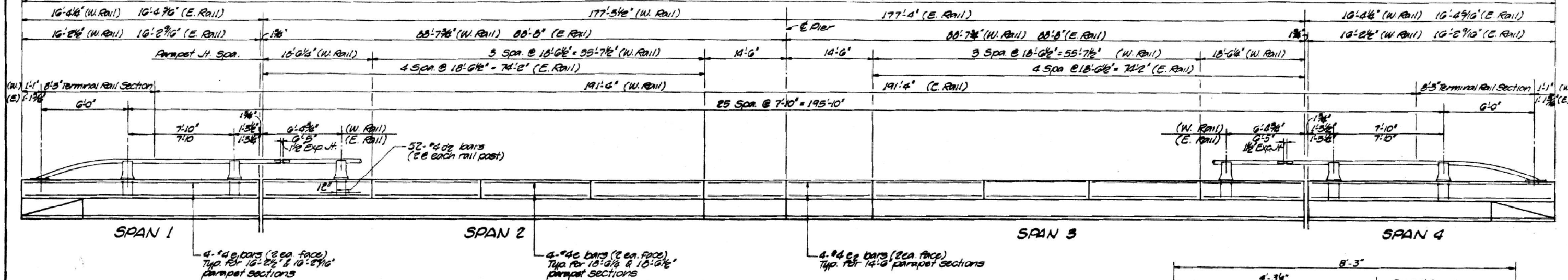

ELEVATION

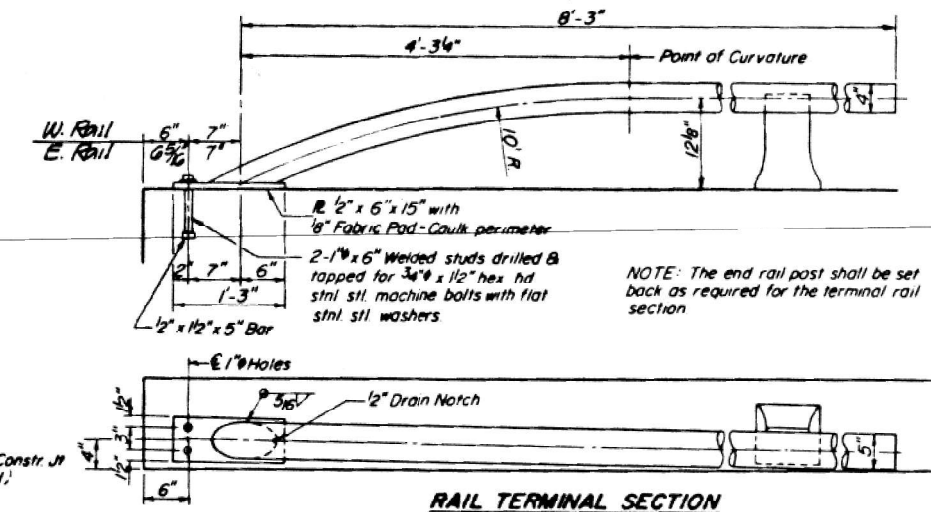

NOTE: The end rail post shall be set back as required for the terminal rail section

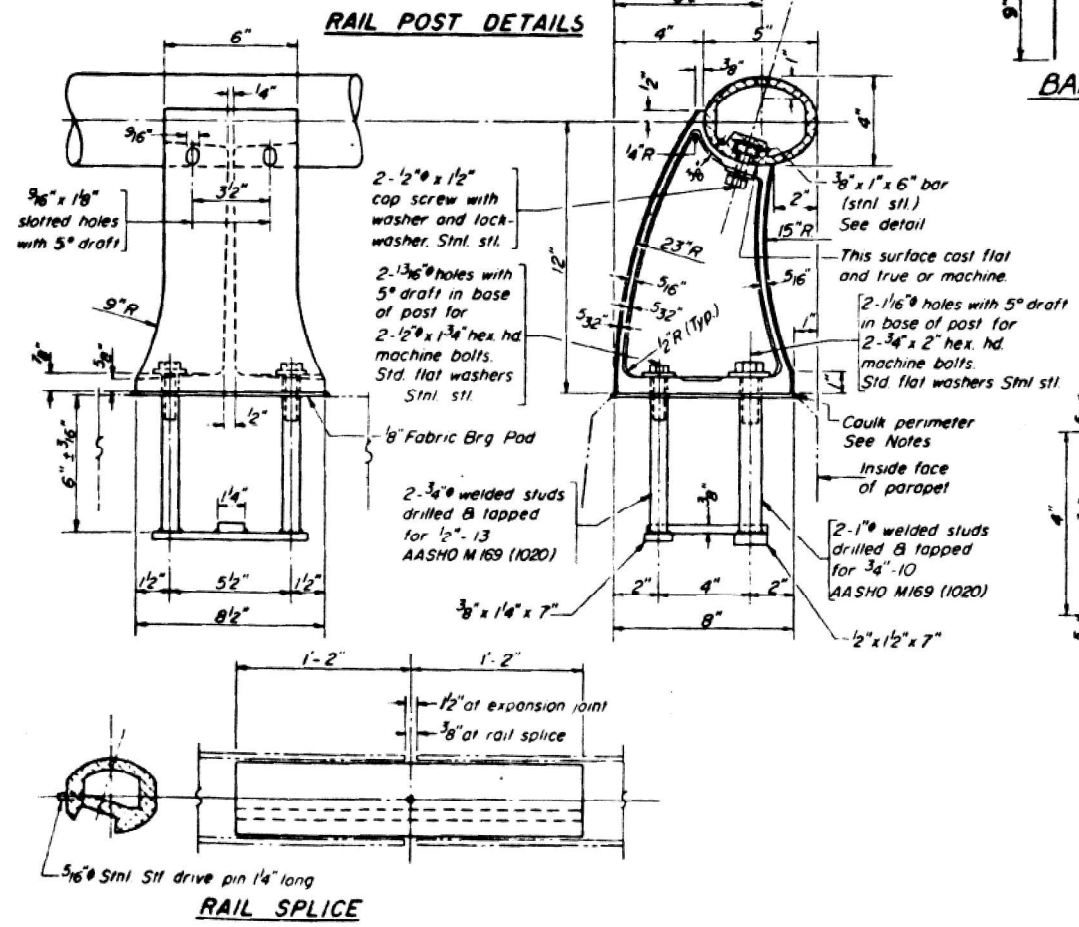

RAIL POST DETAILS

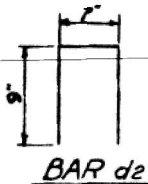

BAR d2

Two component non-staining gray sealing compound with polysulfide liquid polymers-gun grade with primer.

1/2" Preformed Cork Joint Filler (in accordance with Article 715.07 or 715.08) Coat incidental.

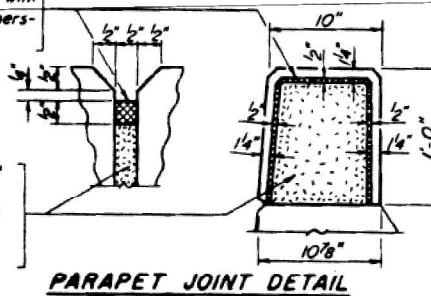

PARAPET JOINT DETAIL

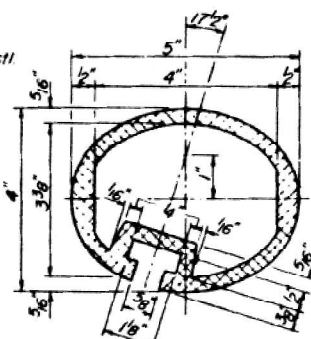

SEC. THRU ELLIPTICAL RAIL SECTION

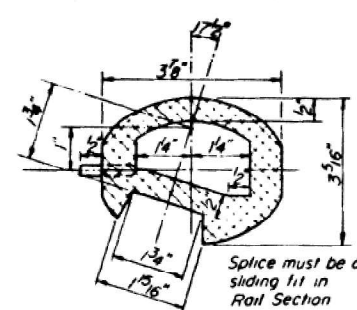

SEC. THRU SPLICE

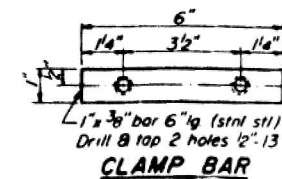

CLAMP BAR

NOTES:

All Aluminum Alloy Extruded Rail shall be supplied in modular lengths of 30 feet, except at the end of bridge or over open joints in bridge deck where the rail shall be attached to a minimum of 2 posts. If the rail is on a horizontal curve of 2300 foot radius or less, the modular lengths may be reduced but shall be attached to a minimum of 2 posts.

All joints in rail shall be spliced per detail.

Provide 1-8" and 2-1/16" Aluminum Shimms for 25% of the Posts. Rail element shall be parallel to Grade - high spots shall be ground and low spots shimmed.

Seal perimeter of base of post to parapet with two component non-staining gray sealing compound with polysulfide liquid polymers, gun grade with primer. Fabric Bearing Pad shall have same dimensions as base of post.

Aluminum alloy rail shall conform to ASTM B221 alloy 6061-T6 or 6351-75 with min. yield 35 ksi, min. tensile 38 ksi, and elongation of 10% in 2 inches.

Stainless steel machine bolts or cap screws shall be in accordance with Article 710.37(a) of the Standard Specifications except Grade BB or BM may be furnished.

PARAPETS & RAILS
BILL OF MATERIAL

Bar	No.	Size	Length	Shape
d2	104	#4	2'-1"	□
e	64	#4	18'-2"	—
e1	16	#4	15'-10"	—
e2	16	#4	14'-3"	—
Reinforcement Bars	Lbs	1240		
Glass X Concrete	Cu Yds	13.5		
Aluminum Railing	Lin Ft	416		

REVISIONS		DATE	BY
1		JUN 9-78	
2		6-9-78	
3			
4			
5			
6			
7			
8			
9			
10			

ALUMINUM RAILING - W.B. LANES

FAI-72 OVER NEW RHY. & TR. 117
FAI-72 SEC 58-62 HYB PROJ.
STA 532+69.66 MACON CO.

HOMER L. CHASTAIN & ASSOCIATES
CONSULTING ENGINEERS
DECATUR ILLINOIS

PROJECT NO. 2109-5
SHEET NO. 22

(Sheet 5 of 7)

STATE OF ILLINOIS
DEPARTMENT OF TRANSPORTATION

EXISTING BRIDGE PLANS - FOR INFORMATION ONLY
SN 058-0070 (WB)

F.A.I. RTE.	SECTION	COUNTY	TOTAL SHEETS	SHEET NO.
72	D7 BRIDGE REPAIRS 2026-3	MACON	108	106
				CONTRACT NO. 74D08
				ILLINOIS FED. AID PROJECT

SHEET 34 OF 36 SHEETS



USER NAME = nhc	DESIGNED - ELH 07/25	REVISED -
ESCA PROJECT NO. = 1445.01	CHECKED - RDP 07/25	REVISED -
PLOT SCALE = 0.2" = 1'-0"	DRAWN - NHC 07/25	REVISED -
PLOT DATE = 1/20/2026	CHECKED - ELH 07/25	REVISED -

ROUTE NO.	SECTION	COUNTY	TOTAL SHEETS	SHEET NO.
FAI-72	SB-2WB	MACON	49	25
FED. ROAD DIST. NO.	ILLINOIS PROJECT			

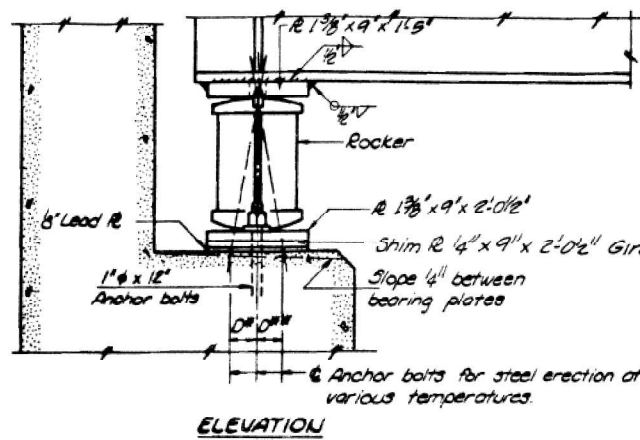

ELEVATION

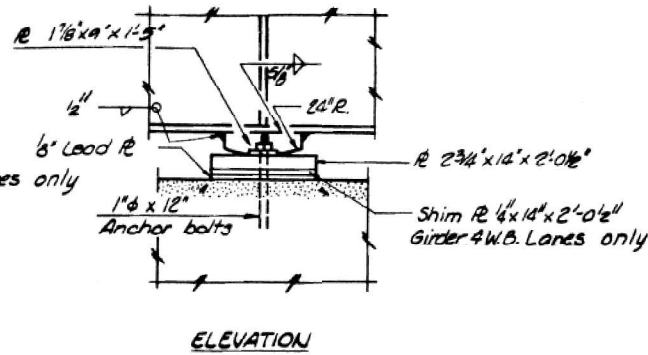

ELEVATION

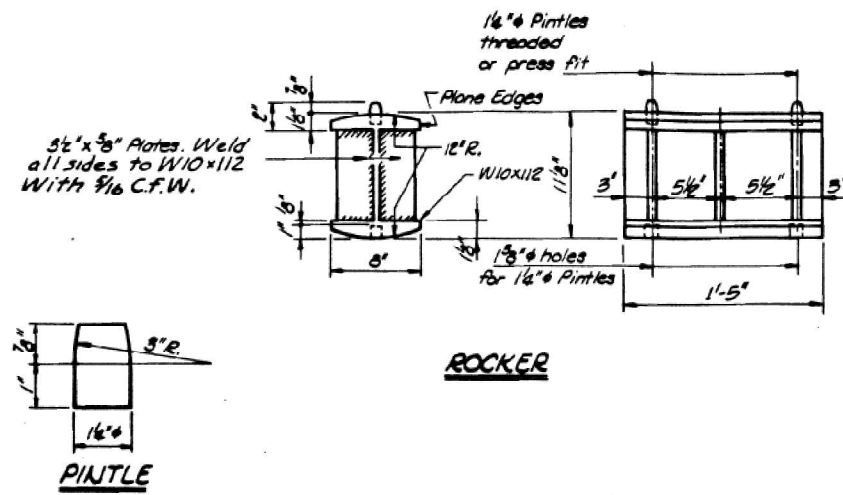

ROCKER

PINTLE

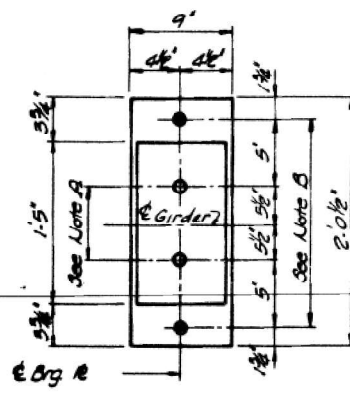

PLAN
AT ABUTMENT

NOTE A
1 1/8" holes - 1" deep in top R for pintles. Thread or press fit pintles into bottom R.

NOTE B
1/2" holes for 1" anchor bolts. 2" x 2" x 5/8" R washers under nut.

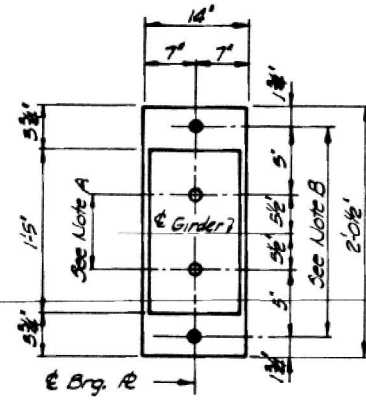

PLAN
AT PIER

NOTES ON SETTING OF ANCHOR BOLTS AT EXPANSION BEARINGS

- a) D^* (Side of brg. away from fixed brg.)
 $D^* = 1/8"$ per each 100' of expansion for every 15° below the normal temperature of 50° F.
- D^{**} (Side of brg. toward fixed brg.)
 $D^{**} = 1/8"$ per each 100' of expansion for every 15° above the normal temperature of 50° F.
- b) After beams have been erected and dimensions D^* or D^{**} determined, holes shall be drilled and anchor bolts shall be grouted in place. All fixed anchor bolts may be built into the masonry.

MOMENT TABLE - Symm Composite & Span (Composite in Positive Moment Areas Only)

INTERIOR GIRDER MOMENT TABLE		
	O.4 Sp. 1	Pier
I_g (in ⁴)	14,770	34,063
I_c (in ⁴)	42,002	—
S_g (in ³)	818	1481
S_c (in ³)	1151	—
Q (K/1)	1.02	1.02
M_Q (K)	435	1291
$F_s Q$ (K/1)	6.4	10.2
S_P (K/1)	.44	.44
M_{sP} (K)	194	440
M_E (K)	757	6.8
M_{imp} (K)	177	142
TOTAL (K)	1130	1188
$F_s + S_P$ (K/1)	11.8	9.6
F_s TOTAL (K)	18.2	19.4
VR (K)	57.3	—

REACTION TABLE INTERIOR GIRDER REACTION TABLE

	ABUTMENT	PIER
R_{P+SP} (K)	44.7	171.2
R_E (K)	49.0	61.4
$Imp.$ (K)	11.5	15.9
R TOTAL (K)	105.2	254.5

I_g and S_g are the moment of inertia and section modulus of the steel section.
 I_c and S_c are the moment of inertia and section modulus of the composite section used in computing F_s .
 VR is the maximum \pm Impact Shear range.

WESTBOUND STRUCTURE

MOMENT TABLE - Symm Composite & Span (Composite in Positive Moment Areas Only)

INTERIOR GIRDER MOMENT TABLE		
	O.4 Sp. 1	Pier
I_g (in ⁴)	14,095	31,964
I_c (in ⁴)	37,443	—
S_g (in ³)	754	1,397
S_c (in ³)	1046	—
Q (K/1)	.95	.95
M_Q (K)	412	1175
$F_s Q$ (K/1)	6.6	10.1
S_P (K/1)	.42	.42
M_{sP} (K)	217	404
M_E (K)	698	57.0
M_{imp} (K)	163	133
TOTAL (K)	1078	1107
$F_s + S_P$ (K/1)	12.4	9.5
F_s TOTAL (K)	19.0	19.6
VR (K)	53.0	—

REACTION TABLE INTERIOR GIRDER REACTION TABLE

	ABUTMENT	PIER
R_{P+SP} (K)	41.5	158.9
R_E (K)	45.7	66.3
$Imp.$ (K)	10.7	15.5
R TOTAL (K)	97.9	240.7

I_g and S_g are the moment of inertia and section modulus of the steel section.
 I_c and S_c are the moment of inertia and section modulus of the composite section used in computing F_s .
 VR is the maximum \pm Impact Shear range.

EASTBOUND STRUCTURE

BEARING SEAT ADJUSTMENT
Bearing seat surfaces shall be constructed or adjusted to the designated elevations within a tolerance of $\pm 1/8"$. Adjustment shall be made either by grinding the surface or by shimming the bearing. Two $1/8"$ adjusting shims, of the dimensions of the bottom bearing plate, shall be provided for each bearing in addition to all other plates or shims.

REVISIONS			DRAWN BY DATE
NO.	DATE	INITIALS	JLH 10-74
1			CHECKED BY DATE
2			6-9-75
3			BOOK NUMBER
4			PROJECT NO.
5			2469-5
6			SHEET NO.
7			25
8			
9			
10			

BEARING DETAILS - W.B. & E.B. LANES

FAI-72 OVER N&W HWY & TR 117
FAI-72 SEC 08-02 HVB PROJ
STA 534+09.00 MACON CO.

HOMER L. CHASTAIN & ASSOCIATES
CONSULTING ENGINEERS
DECATUR, ILLINOIS



USER NAME = nhc	DESIGNED - ELH 07/25	REVISED -
ESCA PROJECT NO. = 1445.01	CHECKED - RDP 07/25	REVISED -
PLOT SCALE = 0.2" / 1'	DRAWN - NHC 07/25	REVISED -
PLOT DATE = 1/20/2026	CHECKED - ELH 07/25	REVISED -

F.A.I. RTE.	SECTION	COUNTY	TOTAL SHEETS	SHEET NO.
72	D7 BRIDGE REPAIRS 2026-3	MACON	108	107
CONTRACT NO. 74D08				
ILLINOIS FED. AID PROJECT				

ROUTE NO.	SECTION	COUNTY	TOTAL SHEETS	SHEET NO.
FAI-72	58-47 NB	MACON	49	32
FED ROAD DIST NO.	ILLINOIS	PROJECT		

210'-0" (W. Rail) End to End of Parapet
210'-0" (E. Rail) End to End of Parapet

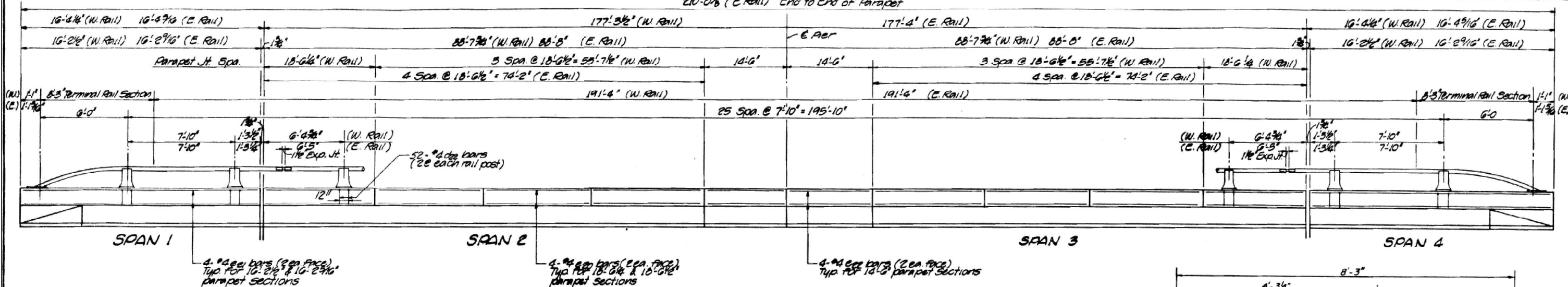

ELEVATION

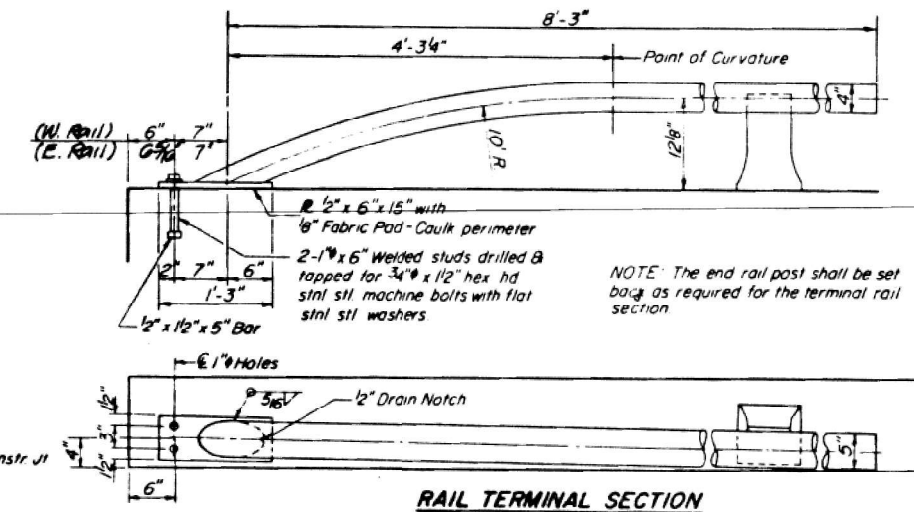

NOTE: The end rail post shall be set back as required for the terminal rail section.

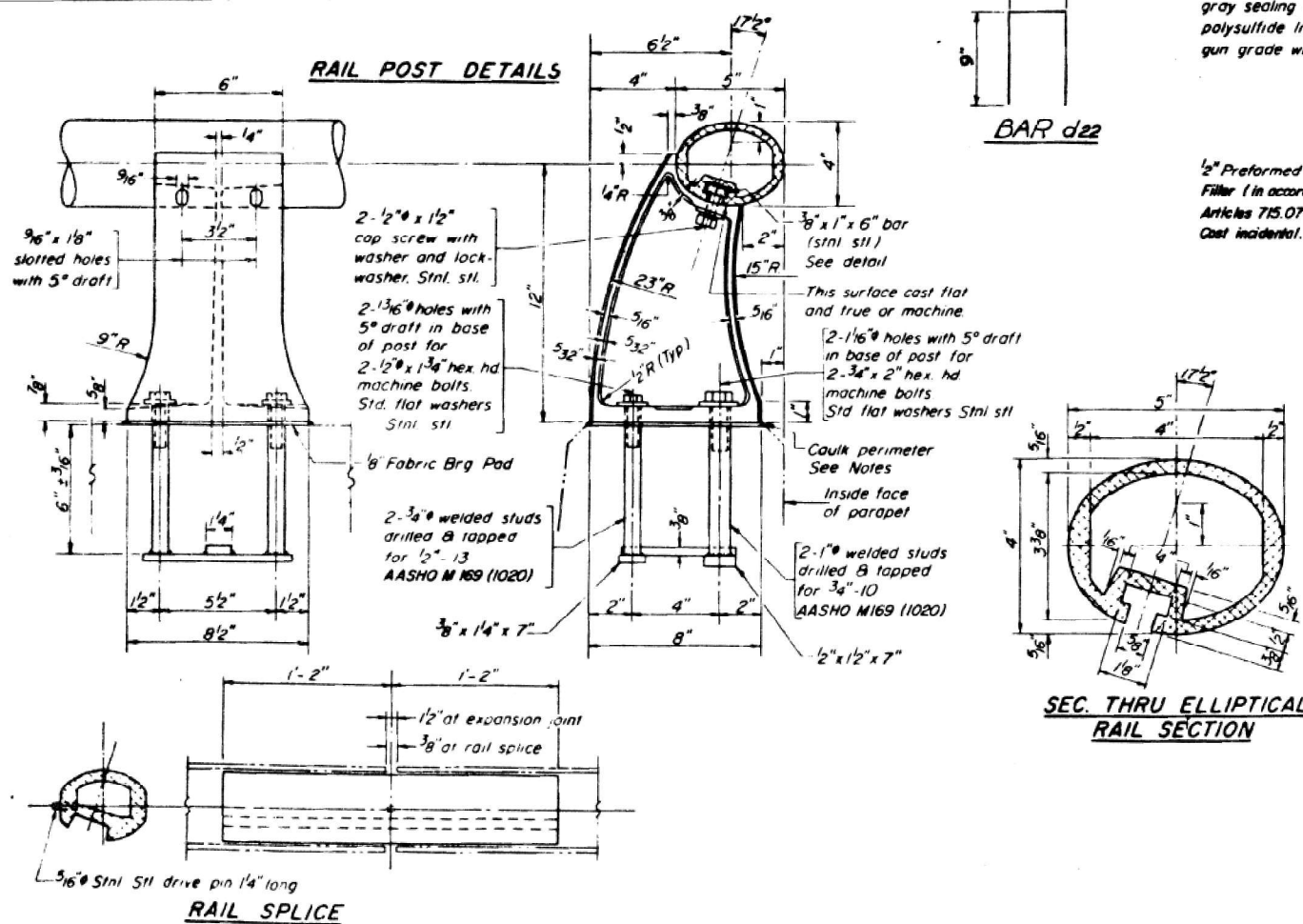

RAIL POST DETAILS

BAR d22

Two component non-staining gray sealing compound with polysulfide liquid polymers - gun grade with primer.

1/2" Preformed Cork Joint Filler (in accordance with Articles 715.07 or 715.08) Coat incidental.

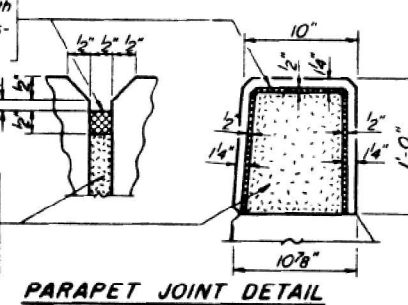

PARAPET JOINT DETAIL

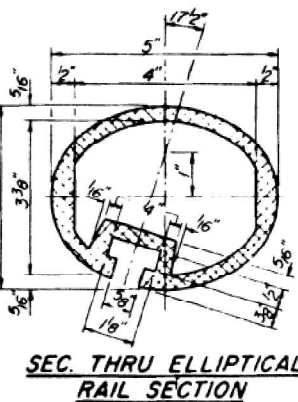

SEC. THRU ELLIPTICAL RAIL SECTION

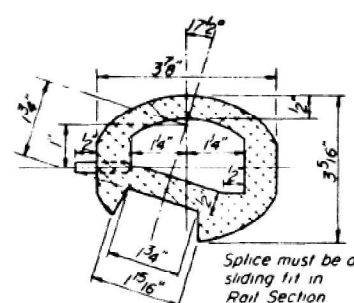

SEC. THRU SPLICE

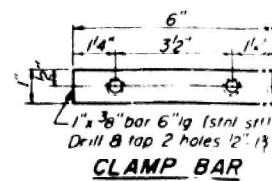

CLAMP BAR

NOTES:

All Aluminum Alloy Extruded Rail shall be supplied in modular lengths of 30 feet, except at the end of bridge or over open joints in bridge deck where the rail shall be attached to a minimum of 2 posts. If the rail is on a horizontal curve of 2300 foot radius or less, the modular lengths may be reduced but shall be attached to a minimum of 2 posts.

All joints in rail shall be spliced per detail. Provide 1-1/8" and 2-1/16" Aluminum Shim for 25% of the Posts. Rail element shall be parallel to Grade - high spots shall be ground and low spots shimmed.

Seal perimeter of base of post to parapet with two component non-staining gray sealing compound with polysulfide liquid polymers, gun grade with primer. Fabric Bearing Pad shall have same dimensions as base of post.

Aluminum alloy rail shall conform to ASTM B221 alloy 6061-T6 or 6351-T5 with min yield 35 ksi, min tensile 38 ksi, and elongation of 10% in 2 inches.

**PARAPETS & RAILS
BILL OF MATERIAL**

Bar	No	Size	Length	Shape
d22	104	#2	2'-1"	□
e20	64	#2	18'-2"	—
e21	16	#2	15'-10"	—
e22	16	#2	14'-5"	—
Reinforcement Bars		Lbs	1240	
Class X Concrete		Cu Yds	13.5	
Aluminum Railing		L in Ft	416	

REVISIONS		DESIGNED BY DATE
1	DATE	JUN 9-74
2	DATE	6-9-74
3	DATE	
4	DATE	
5	DATE	
6	DATE	
7	DATE	
8	DATE	
9	DATE	
10	DATE	

FAI-72 OVER NEW RAY & T.R. 117
FAI-72 SEC 58-02 HVB PROJ
STA. 534+09.66 MACON CO

HOMER L. CHASTAIN & ASSOCIATES
CONSULTING ENGINEERS
DECATUR, ILLINOIS

PROJECT NO. 2069-5
SHEET NO. 32

(Sheet 7 of 7)

STATE OF ILLINOIS
DEPARTMENT OF TRANSPORTATION

EXISTING BRIDGE PLANS - FOR INFORMATION ONLY
SN 058-0071 (EB)

F.A.I. RTE.	SECTION	COUNTY	TOTAL SHEETS	SHEET NO.
72	D7 BRIDGE REPAIRS 2026-3	MACON	108	108
				CONTRACT NO. 74D08
				ILLINOIS FED. AID PROJECT

SHEET 36 OF 36 SHEETS



USER NAME = nhc
ESCA PROJECT NO. = 1445.01
PLOT SCALE = 0.2" / 1"
PLOT DATE = 1/20/2026

DESIGNED - ELH 07/25
CHECKED - RDP 07/25
DRAWN - NHC 07/25
CHECKED - ELH 07/25

REVISED -
REVISED -
REVISED -
REVISED -