

INDEX OF SHEETS

1. COVER SHEET
2. GENERAL NOTES
- 3-4. SUMMARY OF QUANTITIES
5. TYPICAL SECTIONS
6. TRAFFIC CONTROL AND PROTECTION, STANDARD 701400
7. TRAFFIC CONTROL AND PROTECTION, STANDARD 701402 SPECIAL)
8. TEMPORARY CONCRETE BARRIER WALL DELINEATION

HIGHWAY STANDARDS

- 000001-09 STANDARD SYMBOLS, ABBREVIATIONS AND PATTERNS
- 001006 DECIMAL OF AN INCH AND OF A FOOT
- 701001-02 OFF-ROAD OPERATIONS 2L, 2W, MORE THAN 15' AWAY
- 701006-05 OFF-ROAD OPERATIONS 2L, 2W, 15' TO 24" FROM PAVEMENT EDGE
- 701101-05 OFF-ROAD OPERATIONS, MULTILANE, 15' (4.5 m) TO 24" (600 mm) FROM PAVEMENT EDGE
- 701106-02 OFF-ROAD OPERATIONS, MULTILANE, MORE THAN 15 (4.5 m) AWAY
- 701201-05 LANE CLOSURE, 2L, 2W, DAY ONLY, FOR SPEEDS ≥ 45 MPH
- 701301-04 LANE CLOSURE, 2L, 2W, SHORT TIME OPERATIONS
- 701426-09 LANE CLOSURE, MULTILANE INTERMITTENT OR MOVING OPERATION, FOR SPEEDS ≥ 45 MPH
- 701428-01 TRAFFIC CONTROL, SETUP AND REMOVAL, FREEWAY/EXPRESSWAY
- 780001-05 TYPICAL PAVEMENT MARKINGS
- 701901-11 TRAFFIC CONTROL DEVICES
- 704001-08 TEMPORARY CONCRETE BARRIER

**STATE OF ILLINOIS
DEPARTMENT OF TRANSPORTATION**

**PROPOSED
HIGHWAY PLANS**

**F.A.I. ROUTE 55 (I-55)
SECTION (32-1)BP
PROJECT NHPP-03LB(976)
BRIDGE PAINTING
GRUNDY COUNTY
C-93-157-25**

F.A.I. RTE.	SECTION	COUNTY	TOTAL SHEETS	SHEET NO.
55	(32-1)BP	GRUNDY	8	1
		ILLINOIS	CONTRACT NO. 66R94	

D-93-119-25

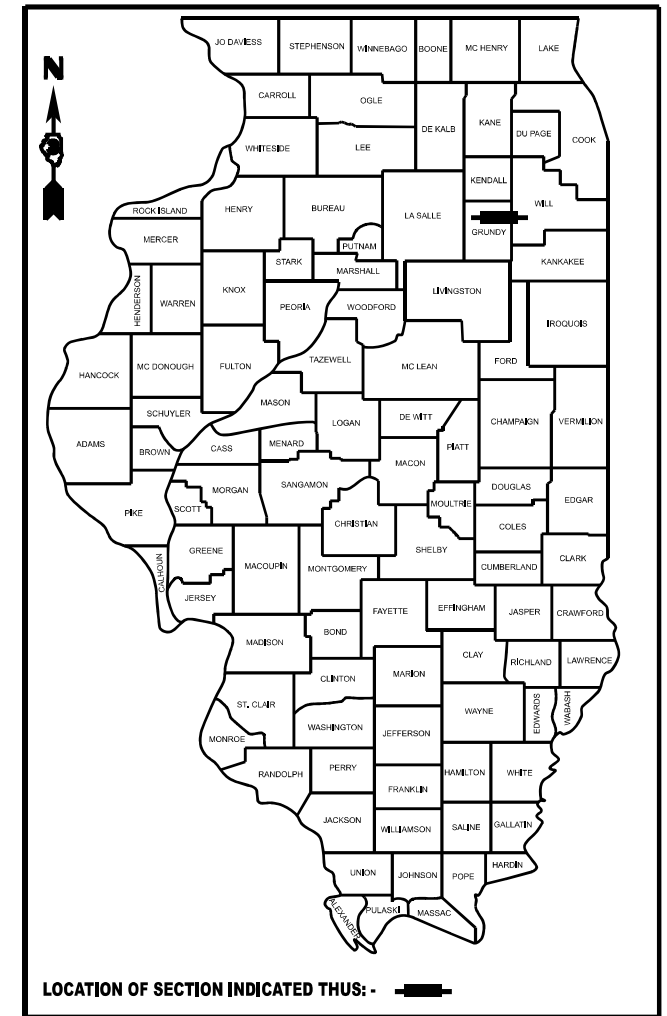

PROJECT LOCATION
STRUCTURE NO. 032-0092
CARRYING CARBON HILL RD. OVER
F.A.I. ROUTE 55 (I-55)
APPROXIMATELY 4.8 MI.
SOUTH OF REED RD.

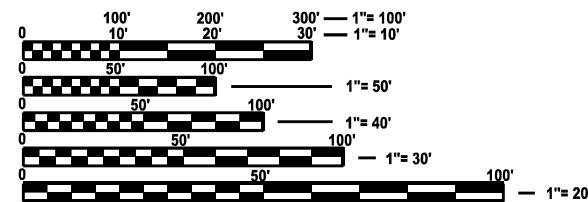
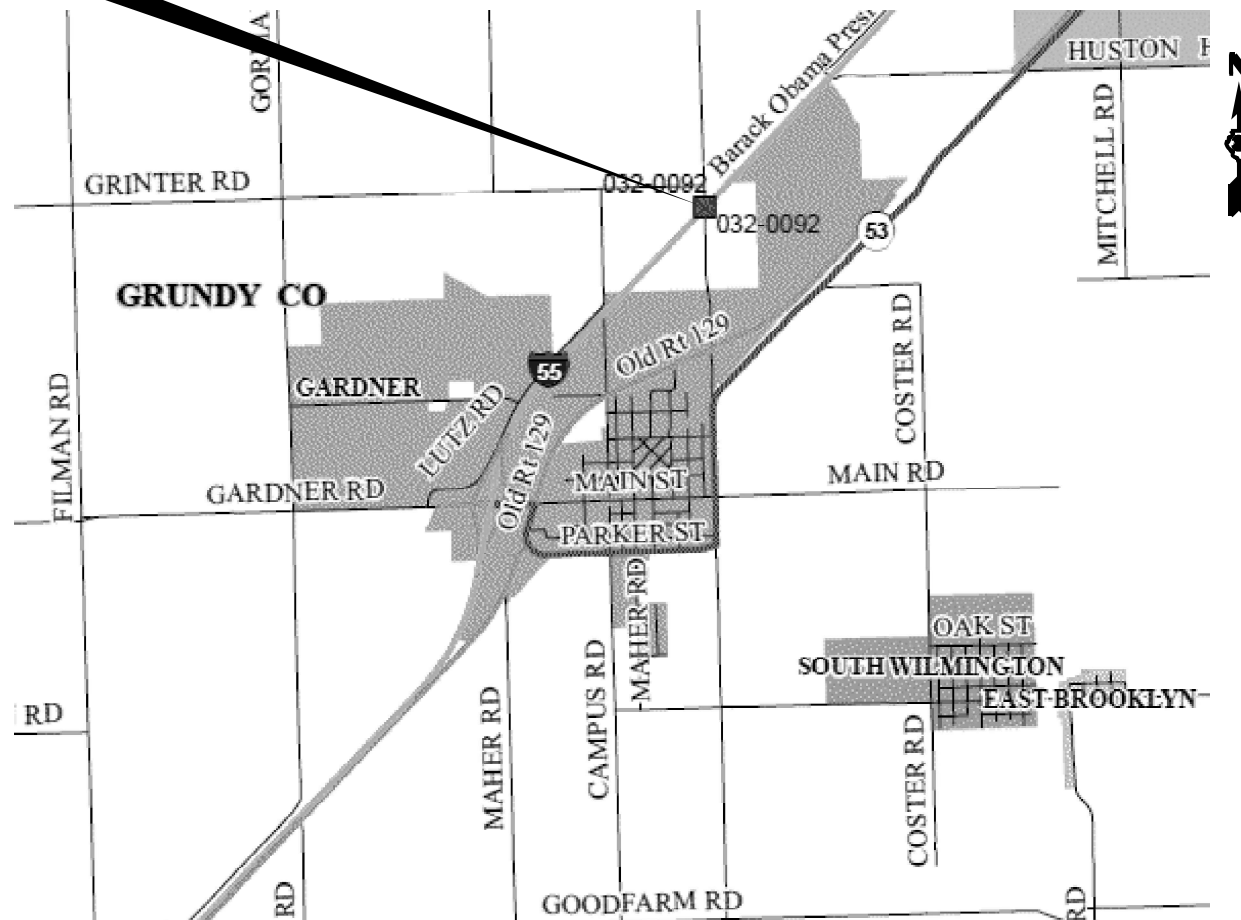

FULL SIZE PLANS HAVE BEEN PREPARED USING STANDARD ENGINEERING SCALES. REDUCED SIZED PLANS WILL NOT CONFORM TO STANDARD SCALES. IN MAKING MEASUREMENTS ON REDUCED PLANS, THE ABOVE SCALES MAY BE USED.

J.U.L.I.E.
JOINT UTILITY LOCATION INFORMATION FOR EXCAVATION
1-800-892-0123
OR 811

PROJECT ENGINEER JUNIOR SENAT P.E.
UNIT CHIEF RON WOODSHANK
DISTRICT 3 (815) 434-6131
CONTRACT NO. 66R94

FUNCTIONAL CLASSIFICATION
URBAN - INTERSTATE
F.A.I. ROUTE 55 (I-55)
2023 ADT = 12,500
P.V. 70.0 % S.U. 3.0 % M.U. 27.0 %

STATE OF ILLINOIS
DEPARTMENT OF TRANSPORTATION

SUBMITTED December 5, 20 25
Trisha Thompson REGIONAL ENGINEER

May 8 20 26
[Signature] ENGINEER OF DESIGN AND ENVIRONMENT

May 8 20 26
[Signature] DIRECTOR OF HIGHWAYS PROJECT IMPLEMENTATION

**PRINTED BY THE AUTHORITY
OF THE STATE OF ILLINOIS**

GENERAL NOTES

PLAN DIMENSIONS AND DETAILS RELATIVE TO THE EXISTING STRUCTURE HAVE BEEN TAKEN FROM EXISTING PLANS ARE SUBJECT TO NOMINAL CONSTRUCTION VARIATIONS. THE CONTRACTOR SHALL FIELD VERIFY EXISTING DIMENSIONS AND DETAILS AFFECTING NEW CONSTRUCTION AND MAKE NECESSARY APPROVED ADJUSTMENTS PRIOR TO CONSTRUCTION OR ORDERING OF MATERIALS. SUCH VARIATIONS SHALL NOT BE CAUSE FOR ADDITIONAL COMPENSATION FOR A CHANGE IN SCOPE OF THE WORK, HOWEVER, THE CONTRACTOR WILL BE PAID FOR THE QUANTITY ACTUALLY FURNISHED AT THE UNIT PRICE BID FOR THE WORK.

CLEANING AND PAINTING EXISTING STEEL / STRUCTURAL STEEL COMPONENTS

CLEANING AND PAINTING OF THE EXISTING STEEL / STRUCTURAL STEEL SHALL BE AS SPECIFIED IN THE SPECIAL PROVISION FOR "CLEANING AND PAINTING EXISTING STEEL STRUCTURES".

THE FOLLOWING STEEL / STRUCTURAL STEEL COMPONENTS SHALL BE CLEANED AND PAINTED.

- | | |
|--------------------------------|--------------------------------|
| a) STRUCTURAL STEEL COMPONENTS | b) STEEL COMPONENTS |
| BEAMS / GIRDERS | DECK DRAINS (DOWN PIPES) |
| STIFFENERS | SCUPPERS (DOWN PIPES) |
| DIAPHRAGMS | STEEL HANDRAILS (WHEN PRESENT) |
| CROSS / LATERAL FRAMING | |
| STEEL COMPONENTS OF BEARINGS | |
| ANGLE BRACKETS / CLIPS | |
| CONNECTION PLATES | |
| ANCHORS / BOLTS | |

OTHER STEEL / STRUCTURAL STEEL COMPONENTS WHEN PRESENT SHALL BE AS DIRECTED BY THE RESIDENT ENGINEER / TECHNICIAN.

STRUCTURE NO. 032-0092 SHALL BE CONSIDERED AS "LOCATION NO. 1".

EXISTING STRUCTURAL STEEL COATINGS FOR STRUCTURE NO. 032-0092 ARE "NON-LEAD" PAINT COATINGS.

SSPC QP1 "CONTRACTOR CERTIFICATION" IS REQUIRED FOR THIS STRUCTURE.

CONTAINMENT OF CLEANING RESIDUE IS REQUIRED TO CONTROL NUISANCE DUST.

CLEANING EXISTING STEEL / STRUCTURAL STEEL COMPONENTS

CLEANING ALL EXISTING STEEL / STRUCTURAL STEEL SHALL BE CLEANED PER NEAR WHITE BLAST CLEANING, "SSPC-SP10".

SEE THE SPECIAL PROVISION FOR "CONTAINMENT AND DISPOSAL OF NON-LEAD PAINT CLEANING RESIDUES.

PAINTING EXISTING STEEL / STRUCTURAL STEEL COMPONENTS

ALL EXISTING STEEL / STRUCTURAL STEEL SHALL BE PAINTED ACCORDING TO THE REQUIREMENTS OF PAINT SYSTEM 1 - OZ/E/U.

- 1) THE COLOR OF THE FINAL FINISH COAT FOR ALL INTERIOR STEEL / STRUCTURAL STEEL SURFACES SHALL BE GRAY, MUNSELL NO 5B 7/1.
- 2) THE COLOR OF THE FINAL FINISH COAT FOR THE EXTERIOR AND BOTTOM FLANGE OF THE FASCIA BEAMS, STEEL COMPONENTS OF FASCIA BEARINGS, DECK DRAINS / SCUPPERS AND STEEL HANDRAILS (WHEN PRESENT) SHALL BE "GREEN, MUNSELL NO. 7.5G 1/2.

REMOVAL AND DISPOSAL OF CLEANING AND PAINTING RESIDUES

THE CONTRACTOR SHALL BE REQUIRED TO SECURE WASTE CONTAINERS THAT REMAIN ON THE JOB SITE. THIS WILL ENTAIL THAT ALL WASTE CONTAINERS CANNOT BE MOVED OR OPENED DURING NON-WORKING HOURS.

WORKING DAYS SHALL BE CHARGED UNTIL THE CONTRACTOR / SUBCONTRACTOR LISCENSED TO REMOVE AND DISPOSE OF NON-LEAD PAINT RESIDUES HAS REMOVED THE WASTE MATERIAL FROM THE JOB SITE ACCORDING TO ALL FEDERAL, STATE AND LOCAL ORDINANCES. IF THE CONTRACTOR / SUBCONTRACTOR FAILS TO REMOVE AND DISPOSE OF THE NON-LEAD PAINT RESIDUES WITHIN THE WORKING DAYS STIPULATED, LIQUIDATED DAMAGES SHALL BE CHARGED PER CALENDAR DAY ACCORDING TO ARTICLE 108.09 OF THE STANDARD SPECIFICATIONS UNTIL SUCH TIME THAT ALL PAINT RESRESUDUES HAVE BEEN REMOVED AND DISPOSED OF.

COMMITMENTS

NONE.

STATE OF ILLINOIS
DEPARTMENT OF TRANSPORTATION
DISTRICT THREE
AS BUILT INFORMATION

SUPERVISING CONSTRUCTION FIELD ENGINEER

RESIDENT ENGINEER / TECHNICIAN

START & END DATES
OF CONSTRUCTION:

INSPECTORS:

STATE OF ILLINOIS
DEPARTMENT OF TRANSPORTATION

GENERAL NOTES

SCALE: SHEET 1 OF 1 SHEETS STA. TO STA.

F.A.I. RTE.	SECTION	COUNTY	TOTAL SHEETS	SHEET NO.
55	(32-1)BP	GRUNDY	8	2
CONTRACT NO. 66R94				
ILLINOIS FED. AID PROJECT				

CONSTRUCTION CODE
BRIDGE PAINTING
90% FED 10% STATE
BRIDGE
0047
S.N. 032-0092

CODE NO.	ITEM	UNIT	TOTAL QUANTITY	
67100100	MOBILIZATION	L SUM	1	1
70100450	TRAFFIC CONTROL AND PROTECTION, STANDARD 701201	L SUM	1	1
70106700	TEMPORARY RUMBLE STRIPS	EACH	8	8
70107025	CHANGEABLE MESSAGE SIGN	CAL DA	28	28
70300100	SHORT TERM PAVEMENT MARKING	FOOT	190	190
70300150	SHORT TERM PAVEMENT MARKING REMOVAL	SQ FT	63	63
70400100	TEMPORARY CONCRETE BARRIER	FOOT	400	400
70400200	RELOCATE TEMPORARY CONCRETE BARRIER	FOOT	1200	1200
70600251	IMPACT ATTENUATORS, TEMPORARY (NON- REDIRECTIVE, NARROW), TEST LEVEL 3	EACH	1	1
70600352	IMPACT ATTENUATORS, RELOCATE (NON- REDIRECTIVE, NARROW), TEST LEVEL 3	EACH	3	3
* 78004630	PREFORMED PLASTIC PAVEMENT MARKING - TYPE D - STANDARD - LINE 6"	FOOT	950	950
* 78009004	MODIFIED URETHANE PAVEMENT MARKING - LINE 4"	FOOT	1880	1880
78300202	PAVEMENT MARKING REMOVAL - WATER BLASTING	SQ FT	475	475
X5060601	CONTAINMENT AND DISPOSAL OF NON-LEAD PAINT CLEANING RESIDUES NO. 1	L SUM	1	1

***SPECIALITY ITEMS**

MODEL: Default
FILE NAME: c:\pwwork\woodshant\1139837\66R94.dgn

USER NAME = Cladele,O,Popoola	DESIGNED - RW	REVISED -
	DRAWN - RW	REVISED -
	CHECKED - JS	REVISED -
PLOT DATE = 12/1/2025	DATE - 7/17/2025	REVISED -

STATE OF ILLINOIS
DEPARTMENT OF TRANSPORTATION

SUMMARY OF QUANTITIES

SCALE: SHEET 1 OF 2 SHEETS STA. TO STA.

F.A.I. RTE.	SECTION	COUNTY	TOTAL SHEETS	SHEET NO.
55	(32-1)BP	GRUNDY	8	3
			CONTRACT NO. 66R94	
		ILLINOIS FED. AID PROJECT		

CODE NO.	ITEM	UNIT	TOTAL QUANTITY	CONSTRUCTION CODE
				BRIDGE PAINTING 90% FED 10% STATE
				BRIDGE 0047 S.N. 032-0092
X5067501	BRIDGE CLEANING AND PAINTING WARRANTY NUMBER 1	L SUM	1	1
X7010208	TRAFFIC CONTROL AND PROTECTION, STANDARD 701402 (SPECIAL)	EACH	1	1
Z0010501	CLEANING AND PAINTING STEEL BRIDGE NO. 1	L SUM	1	1

MODEL: Default
FILE NAME: c:\p\work\pww\woodshank\1139837\66R94.dgn

USER NAME = ronakd.woodshank	DESIGNED - RW	REVISED -
	DRAWN - RW	REVISED -
	CHECKED - JS	REVISED -
PLOT DATE = 7/17/2025	DATE - 7/17/2025	REVISED -

**STATE OF ILLINOIS
DEPARTMENT OF TRANSPORTATION**

SUMMARY OF QUANTITIES

SCALE: SHEET 2 OF 2 SHEETS STA. TO STA.

F.A.I. RTE.	SECTION	COUNTY	TOTAL SHEETS	SHEET NO.
55	(32-1)BP	GRUNDY	8	4
			CONTRACT NO. 66R94	
		ILLINOIS FED. AID PROJECT		

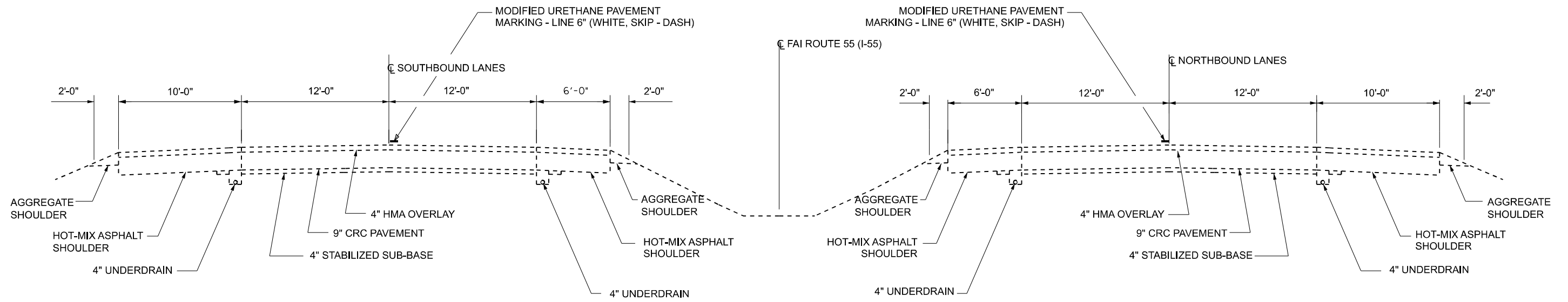

TYPICAL SECTION

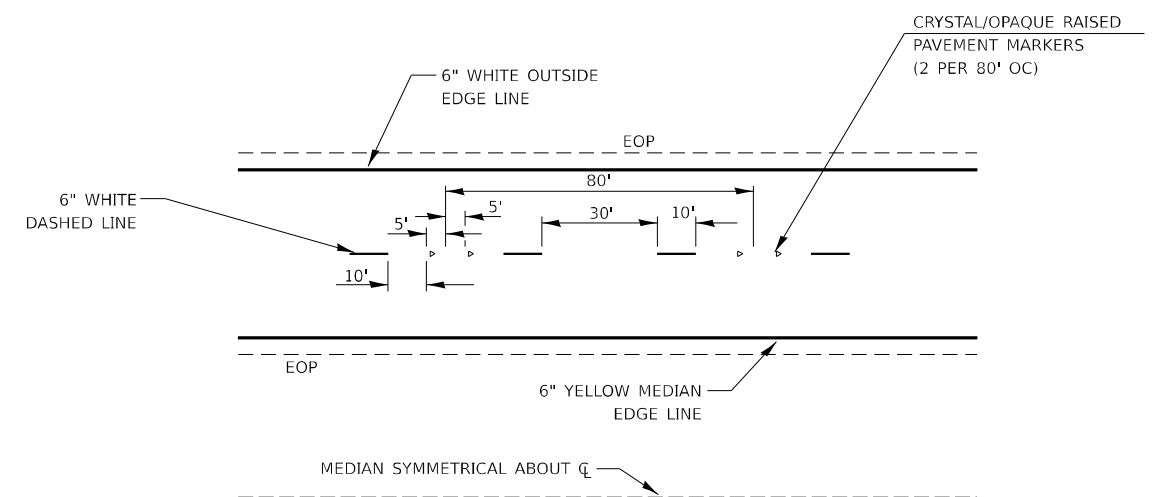

TYPICAL PAVEMENT MARKINGS

MODEL: Default
 FILE NAME: c:\pwwork\woodshank\rd1130837\66R94.dgn

USER NAME = ronakd.woodshank	DESIGNED - RW	REVISED -
	DRAWN - RW	REVISED -
	CHECKED - JS	REVISED -
PLOT DATE = 7/23/2025	DATE - 7/17/2025	REVISED -

**STATE OF ILLINOIS
 DEPARTMENT OF TRANSPORTATION**

TYPICAL SECTION

SCALE: SHEET 1 OF 1 SHEETS STA. TO STA.

F.A.I. RTE.	SECTION	COUNTY	TOTAL SHEETS	SHEET NO.
55	(32-1)BP	GRUNDY	8	5
CONTRACT NO. 66R94				
ILLINOIS FED. AID PROJECT				

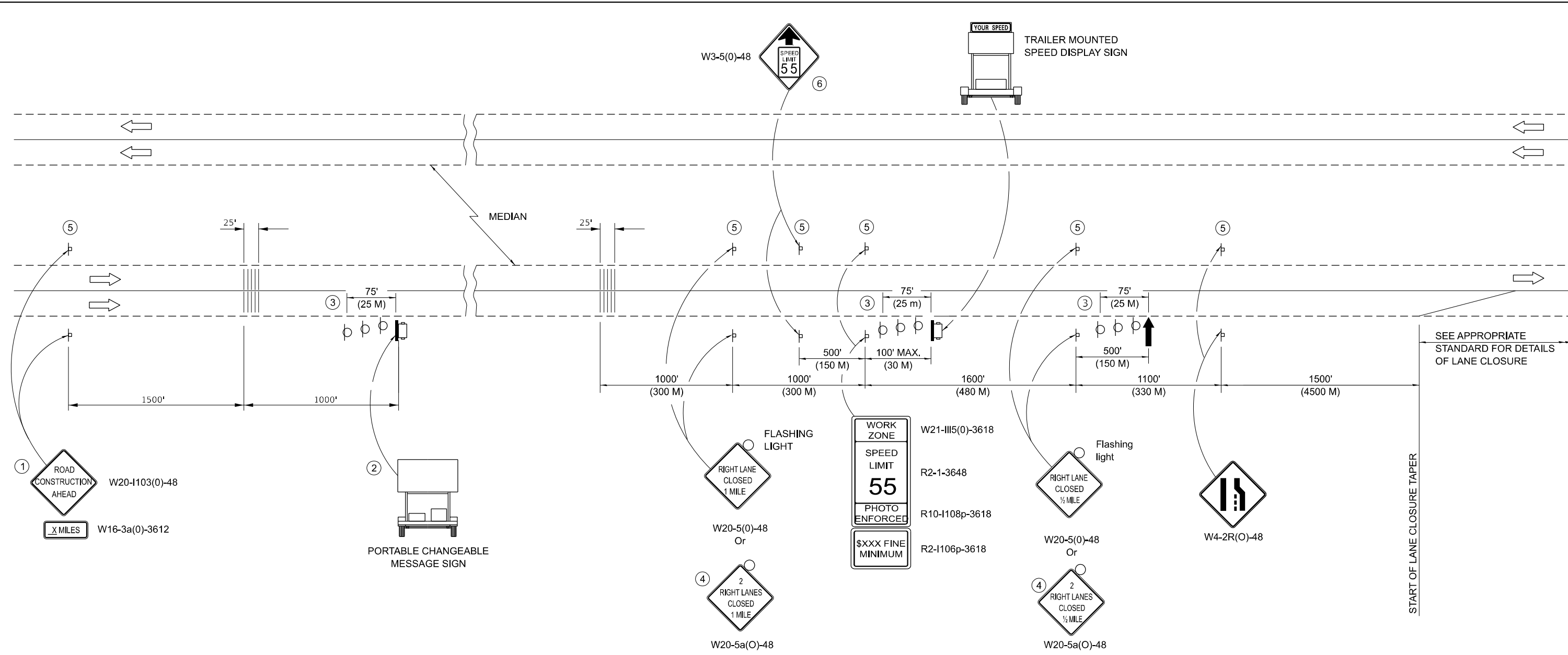

SYMBOLS

- ↑ ARROW BOARD
- ☐ TRAILER MOUNTED SIGN
- ⊥ SIGN
- TYPE II BARRICADE, DRUM, OR VERTICAL BARRICADE WITH MONODIRECTIONAL FLASHING LIGHT

- ① THE ROAD CONSTRUCTION AHEAD SIGN SHALL BE LOCATED 3 TO 5 MILES IN ADVANCE OF THE PROJECT LIMITS.
- ② THE MESSAGE BOARD SHALL BE USED TO DISPLAY STATUS OF LANES WITHIN THE PROJECT. THE PRIMARY MESSAGES SHALL BE:
 "RIGHT LANE CLOSED" / " X MILES AHEAD"
 "LEFT LANE CLOSED" / " X MILES AHEAD"
 "ALL LANES OPEN"
- ③ THREE, TYPE II BARRICADES, DRUMS, OR VERTICAL BARRICADES AT 25' (8 M) CENTERS.
- ④ THIS SIGN SHALL BE USED WHEN 2 LANES ARE CLOSED.
- ⑤ THIS SIGN SHALL BE OMITTED WHEN MEDIAN WIDTH IS LESS THAN 10' (3 M).
- ⑥ THIS SIGN SHALL ONLY BE USED IF THE EXISTING SPEED LIMIT IS GREATER THAN 65 MPH.

GENERAL NOTES

THIS STANDARD IS USED WHERE AT ANY TIME A LANE IS CLOSED ON A FREEWAY/EXPRESSWAY. WHEN THE LEFT LANE IS CLOSED, LEFT LANE CLOSED SIGNS SHALL BE SUBSTITUTED FOR THE RIGHT LANE CLOSED SIGNS.

THE FIRST SIGN AND THE MESSAGE BOARD ARE STATIONARY.

THE LAST FOUR SIGNS AND ARROW BOARD SHALL BE MOVED AS NECESSARY TO MAINTAIN THE REQUIRED DISTANCE FROM THE START OF THE LANE CLOSURE TAPER(S).

SEE STANDARD 701901 FOR TEMPORARY RUMBLE STRIP DETAILS

ALL DIMENSIONS ARE IN INCHES (MILLIMETERS) UNLESS OTHERWISE SHOWN.

MODEL: Default
 FILE NAME: c:\pwwork\woodshank\1139837\66R94.dgn

USER NAME = ronakd.woodshank	DESIGNED - RW	REVISED -
	DRAWN - RW	REVISED -
	CHECKED - JS	REVISED -
PLOT DATE = 7/17/2025	DATE - 7/17/2025	REVISED -

STATE OF ILLINOIS
 DEPARTMENT OF TRANSPORTATION

TRAFFIC CONTROL AND PROTECTION, STANDARD 701400

SCALE: SHEET 1 OF 1 SHEETS STA. TO STA.

F.A.I. RTE.	SECTION	COUNTY	TOTAL SHEETS	SHEET NO.
55	(32-1)BP	GRUNDY	8	6
CONTRACT NO. 66R94				
ILLINOIS FED. AID PROJECT				

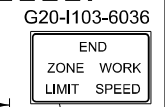
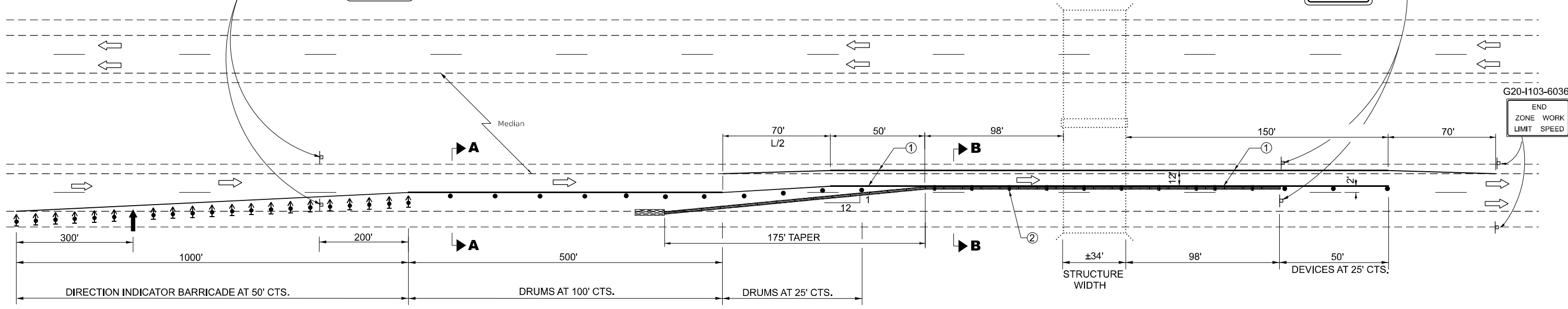
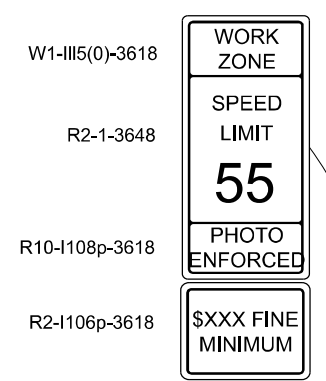
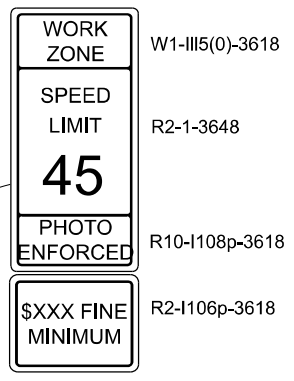

SEQUENCE OF LANE CLOSURES

1. NORTHBOUND DRIVE LANE - INITIAL LANE CLOSURE SET-UP
2. NORTHBOUND PASSING LANE - RELOCATED TRAFFIC CONTROL
3. SOUTHBOUND DRIVE LANE - RELOCATED TRAFFIC CONTROL FROM NORTHBOUND LANES
4. SOUTHBOUND PASSING LANE - RELOCATED TRAFFIC CONTROL

GENERAL NOTES

THIS STANDARD IS USED WHERE AT ANY TIME ANY VEHICLE, EQUIPMENT, WORKERS OR THEIR ACTIVITIES WILL ENCROACH ON THE PAVEMENT OR ON THE SHOULDER WITHIN 24 (600) OF THE EDGE OF PAVEMENT FOR DAYLIGHT OPERATION EXCEEDING ONE DAY AND WHERE TEMPORARY CONCRETE BARRIER IS UTILIZED.

THIS STANDARD MUST ALWAYS BE USED IN COMBINATION WITH STANDARD 701400.

WHEN WORK IS BEING PERFORMED IN THE LEFT LANE, THE SET UP WOULD BE A MIRROR IMAGE TO WHAT IS SHOWN.

TEMPORARY CONCRETE BARRIER SHALL BE ACCORDING TO STANDARD 704001.

CALCULATE L AS FOLLOWS:

NORMAL POSTED SPEED: 45 MPH OR MORE

FORMULA: ENGLISH $L = (W)(S)$

W = WIDTH OF OFFSET IN FEET.

S = NORMAL POSTED SPEED IN MPH.

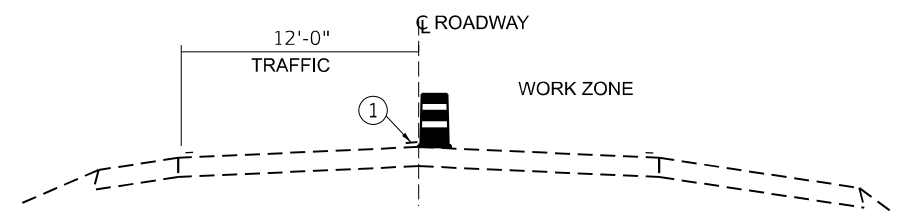

SECTION A-A

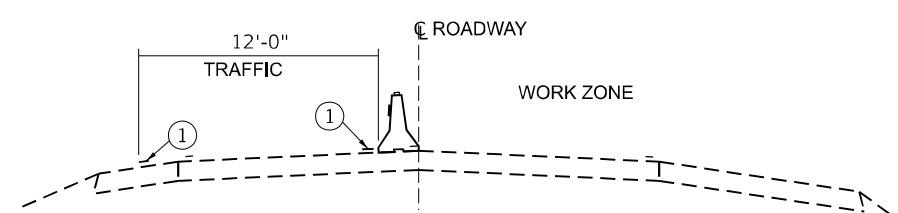

SECTION B-B

SYMBOLS

- ↑ ARROW BOARD
- ▨ WORK AREA
- ⊥ SIGN
- ↑ DIRECTION INDICATOR BARRICADE WITH STEADY BURN MONODIRECTIONAL LIGHT
- DRUM, WITH STEADY BURN MONODIRECTIONAL LIGHT
- TEMPORARY CONCRETE BARRIER
- ◁ MONODIRECTIONAL GUARDRAIL REFLECTOR
- ▨ IMPACT ATTENUATOR

- ① TEMPORARY PAVEMENT MARKING TAPE SHALL BE PLACED THROUGHOUT THE TAPER AND ALONG-SIDE THE WORK AREA. THE RIGHT EDGE LINE SHALL BE WHITE AND THE LEFT EDGE LINE SHALL BE YELLOW.
- ② BARRIER WALL DELINEATION SHALL BE ACCORDING TO THE TEMPORARY CONCRETE BARRIER WALL DELINEATION DETAILS. SEE SHEET XXX OF XXX.
- ③ VERTICAL BARRICADES SHALL NOT BE USED IN LANE SHIFT TAPER.

MODEL: Default
FILE NAME: c:\pwworking\woodshank\rd1130837\66R94.dgn

USER NAME = ronakd.woodshank	DESIGNED - RW	REVISED -
	DRAWN - RW	REVISED -
	CHECKED - JS	REVISED -
PLOT DATE = 7/17/2025	DATE - 7/17/2025	REVISED -

**STATE OF ILLINOIS
DEPARTMENT OF TRANSPORTATION**

TRAFFIC CONTROL AND PROTECTION, STANDARD 701402 (SPECIAL)

SCALE: SHEET 1 OF 1 SHEETS STA. TO STA.

F.A.I. RTE.	SECTION	COUNTY	TOTAL SHEETS	SHEET NO.
55	(32-1)BP	GRUNDY	8	7
CONTRACT NO. 66R94			ILLINOIS FED. AID PROJECT	

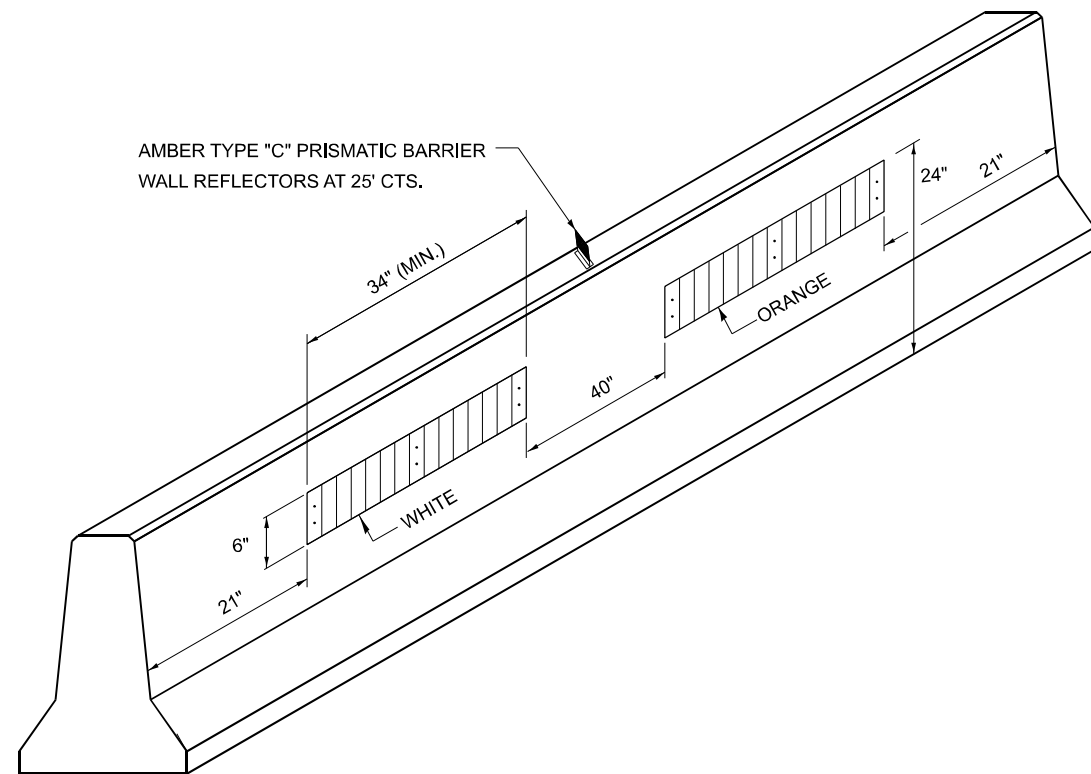

**LINEAR DELINEATOR PANELS
FOR TEMPORARY CONCRETE BARRIER**

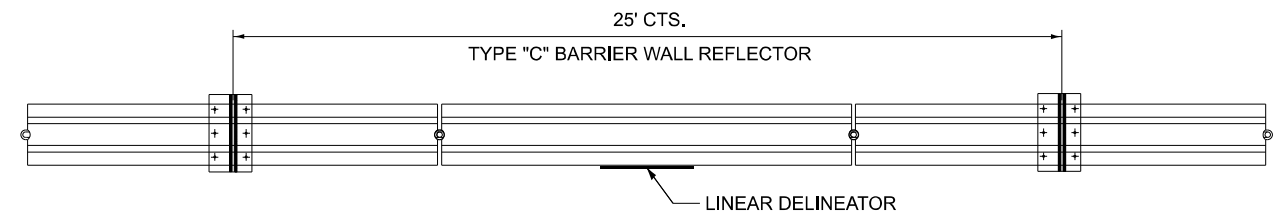

TYPE "C" REFLECTOR FOR TEMPORARY CONCRETE BARRIER

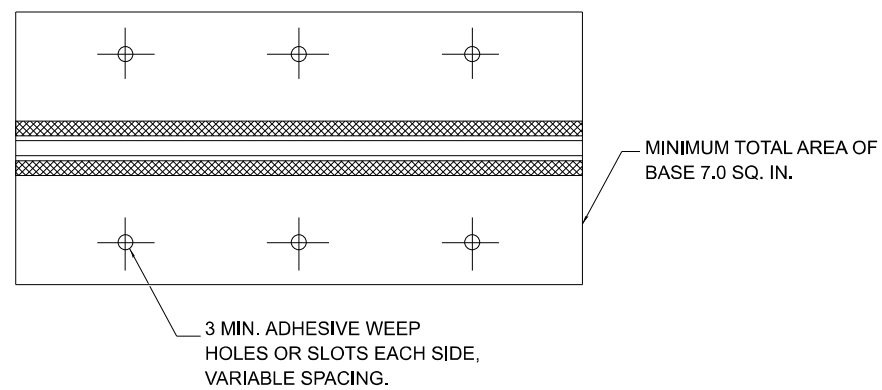
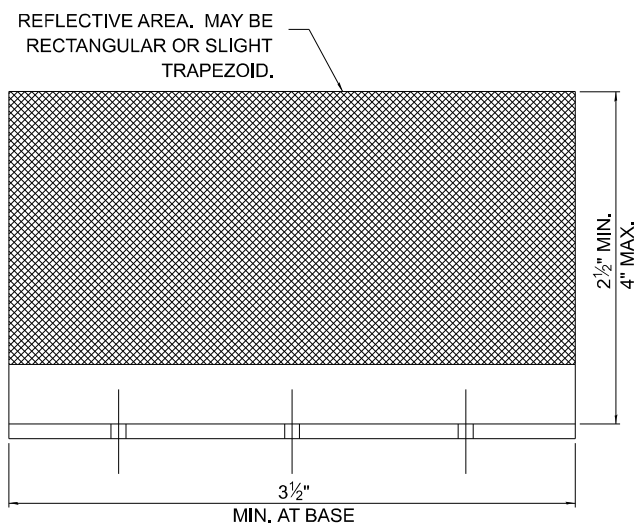

REFLECTOR TYPE C

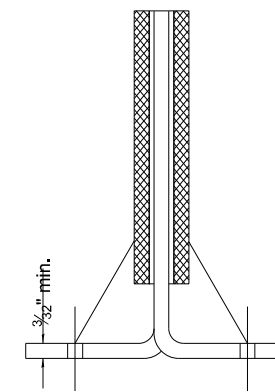

Cross section may be "T" or "L" shaped and may have side supports at ends.

MODEL: Default
FILE NAME: c:\pwwork\woodshank\1130937\66R94.dgn

USER NAME = ronak.woodshank	DESIGNED - RW	REVISED -
	DRAWN - RW	REVISED -
	CHECKED - JS	REVISED -
PLOT DATE = 7/17/2025	DATE - 7/17/2025	REVISED -

**STATE OF ILLINOIS
DEPARTMENT OF TRANSPORTATION**

TEMPORARY CONCRETE BARRIER WALL DELINEATION

SCALE: SHEET 1 OF 1 SHEETS STA. TO STA.

F.A.I. RTE.	SECTION	COUNTY	TOTAL SHEETS	SHEET NO.
55	(32-1)BP	GRUNDY	8	8
CONTRACT NO. 66R94			ILLINOIS FED. AID PROJECT	