

ELEVATION AT PIER

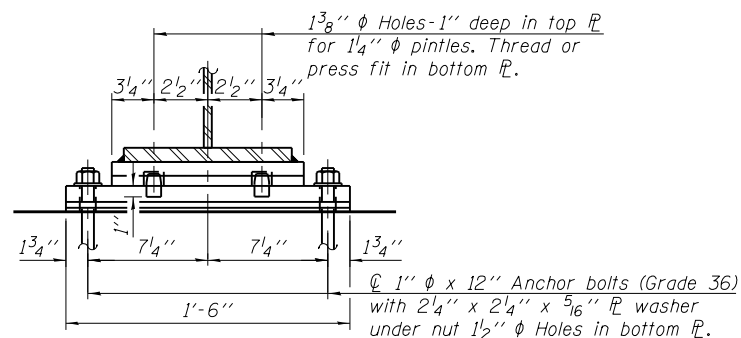

SECTION B-B

FIXED BEARING AT PIERS 2 & 3

(22 Required)

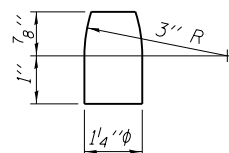

PINTLE

BILL OF MATERIAL

Item	Unit	Total
Anchor Bolts, 1"	Each	44

NOTES

- Anchor bolts shall be ASTM F1554 all-thread (or an Engineer-approved alternate material) of the grade(s) and diameter(s) specified. The corresponding specified grade of AASHTO M314 anchor bolts may be used in lieu of ASTM F1554.
- Anchor bolts at fixed bearings may be either cast in place or installed in holes drilled after the supported member is in place.
- Drilled and set anchor bolts shall be installed according to Article 521.06 of the Standard Specifications.
- The structural steel plates and pintles of the fixed bearings shall conform to the requirements of AASHTO M 270 Grade 50.
- Two 1/8 in. adjusting shims shall be provided for each bearing in addition to all other plates or shims and placed as shown on bearing details.
- All bearing plates, side retainers, anchor bolts, nuts, washers and pintles shall be galvanized according to AASHTO M111 or M232 as applicable.

H:\projects\2015\0223\CAD\Structural\dwg\016-1149-Final\00\Di60J15-s30-fixed-brg-dt.dgn
 3/27/2014 4:55:42 PM

USER NAME =	DESIGNED - J.Z.	REVISED -
	CHECKED - J.A.Z.	REVISED -
PLOT SCALE =	DRAWN - E.E.J.	REVISED -
PLOT DATE =	DATE - 3/31/2014	REVISED -

F.A.I. RTE.	SECTION	COUNTY	TOTAL SHEETS	SHEET NO.
94	1920-B	COOK	142	94
CONTRACT NO. 60J15				
ILLINOIS FED. AID PROJECT				