

H:\projects\2011\0223\CAD\Structural\06-1149-Final\00\060105-s34-abut-dt.dgn
 3/27/2014 4:56:48 PM

USER NAME =	DESIGNED - J.Z.	REVISED -
PLLOT SCALE =	CHECKED - J.A.Z.	REVISED -
PLLOT DATE =	DRAWN - E.E.J.	REVISED -
	DATE - 3/31/2014	REVISED -

F.A.I. RTE.	SECTION	COUNTY	TOTAL SHEETS	SHEET NO.
94	1920-B	COOK	142	98
CONTRACT NO. 60J15				
ILLINOIS FED. AID PROJECT				

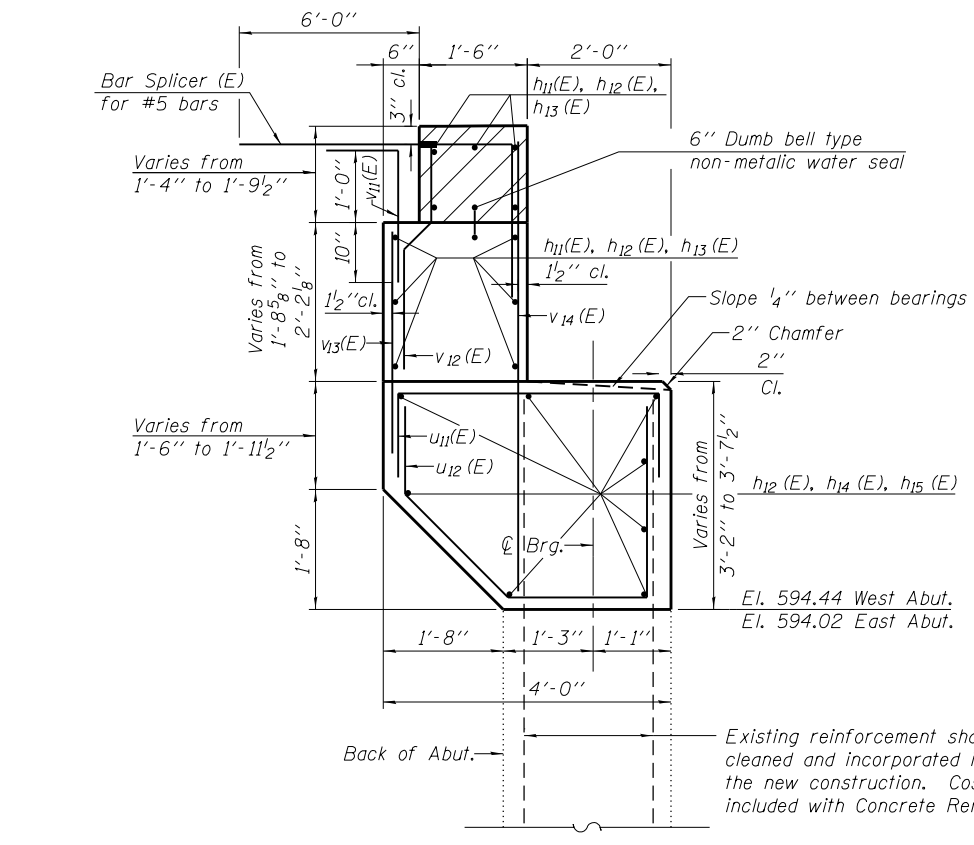
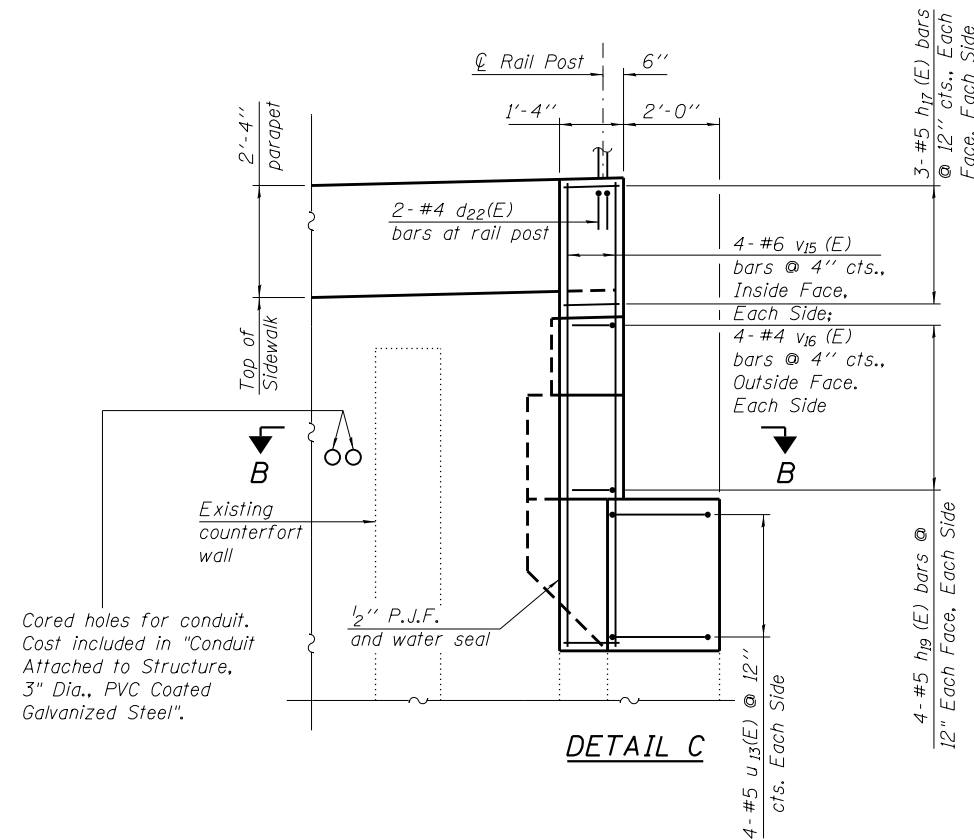

SECTION A-A

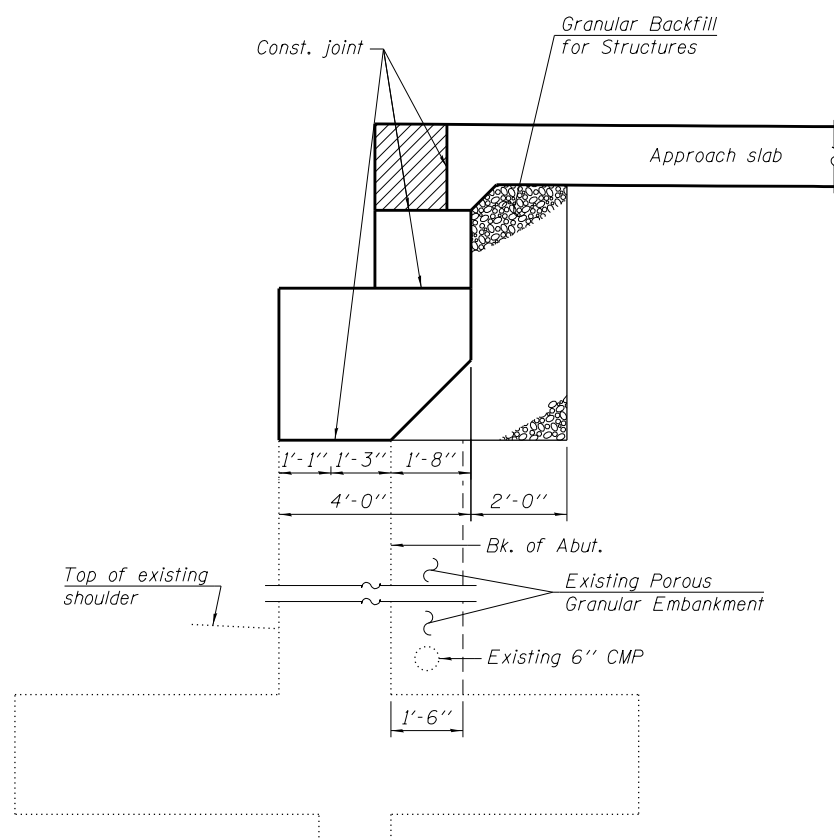

SECTION THRU ABUTMENTS

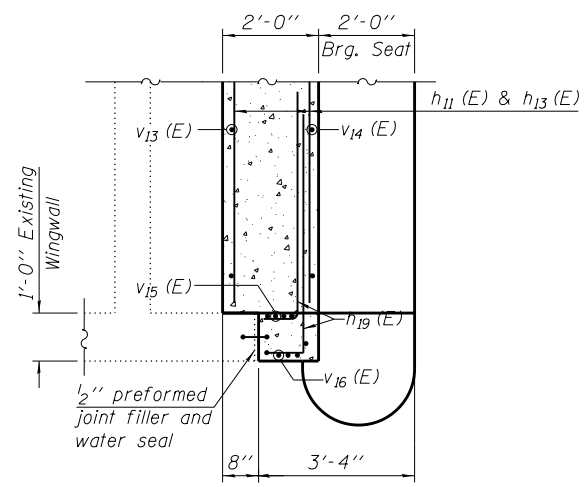

SECTION B-B

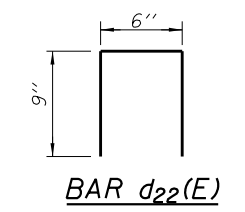

BAR d22(E)

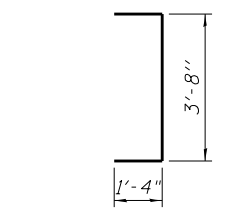

BAR u11(E)

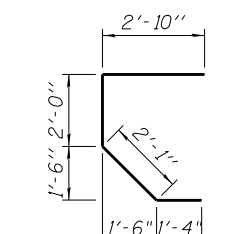

BAR u12(E)

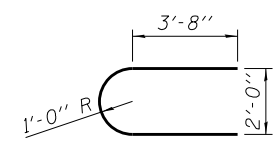

BAR u13(E)

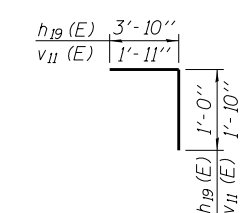

BAR h19(E) & v11(E)

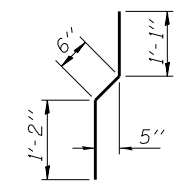

BAR v12(E)

WEST ABUTMENT
BILL OF MATERIAL

Bar	No.	Size	Length	Shape
d22(E)	4	#4	2'-0"	□
h11(E)	22	#5	25'-1"	—
h12(E)	19	#5	20'-8"	—
h13(E)	11	#5	13'-2"	—
h14(E)	16	#5	25'-6"	—
h15(E)	8	#5	14'-6"	—
h16(E)	3	#5	17'-3"	—
h17(E)	12	#5	1'-0"	—
h18(E)	3	#5	5'-3"	—
h19(E)	16	#5	4'-10"	—
u11(E)	85	#5	6'-4"	—
u12(E)	85	#5	8'-3"	—
u13(E)	8	#5	10'-6"	—
v11(E)	83	#5	3'-9"	—
v12(E)	83	#5	2'-9"	—
v13(E)	83	#5	3'-4"	—
v14(E)	83	#5	6'-0"	—
v15(E)	8	#6	9'-6"	—
v16(E)	8	#4	9'-6"	—
Structure Excavation		Cu. yd	117	
Concrete Structures		Cu. yd	51.1	
Reinforcement Bars, Epoxy Coated		Pound	4,770	
Concrete Sealer		Sq. Ft.	771	
Granular Backfill for Structures		Cu. yd	46	

EAST ABUTMENT
BILL OF MATERIAL

Bar	No.	Size	Length	Shape
d22(E)	4	#4	2'-0"	□
h11(E)	22	#5	25'-1"	—
h12(E)	19	#5	20'-8"	—
h13(E)	11	#5	13'-2"	—
h14(E)	16	#5	25'-6"	—
h15(E)	8	#5	14'-6"	—
h16(E)	3	#5	17'-3"	—
h17(E)	12	#5	1'-0"	—
h18(E)	3	#5	5'-3"	—
h19(E)	16	#5	4'-10"	—
u11(E)	85	#5	6'-4"	—
u12(E)	85	#5	8'-3"	—
u13(E)	8	#5	10'-6"	—
v11(E)	83	#5	3'-9"	—
v12(E)	83	#5	2'-9"	—
v13(E)	83	#5	3'-4"	—
v14(E)	83	#5	6'-0"	—
v15(E)	8	#6	9'-6"	—
v16(E)	8	#4	9'-6"	—
Structure Excavation		Cu. yd	100	
Concrete Structures		Cu. yd	51.4	
Reinforcement Bars, Epoxy Coated		Pound	4,770	
Concrete Sealer		Sq. Ft.	772	
Granular Backfill for Structures		Cu. yd	46	

NOTES

- For details of Bar Splicers, see sheet S49.
- Hatched area to be poured after superstructure false work has been removed. Quantity of concrete included with Concrete Superstructure.