

END VIEW

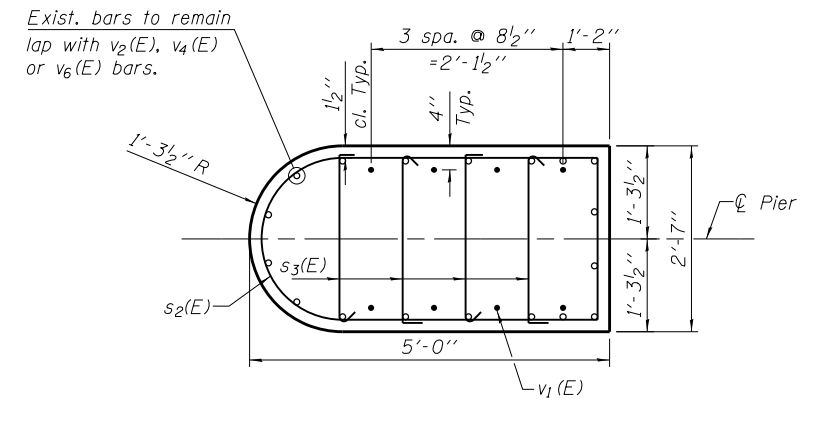

SECTION B-B

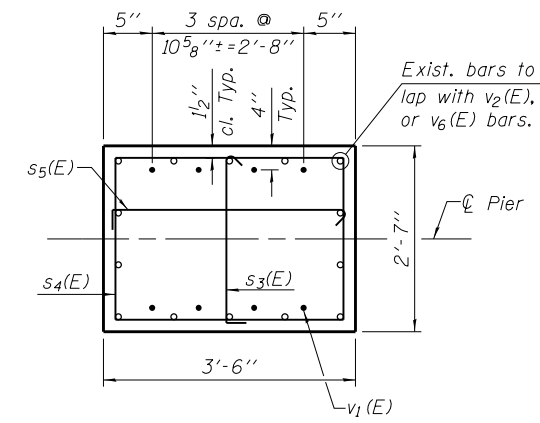

SECTION C-C

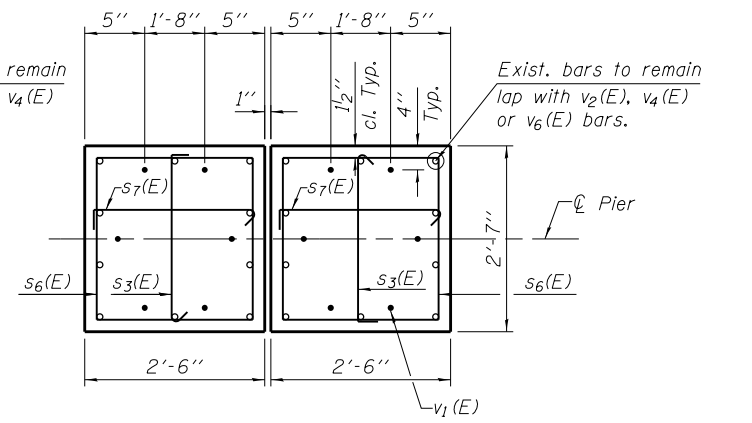

SECTION D-D

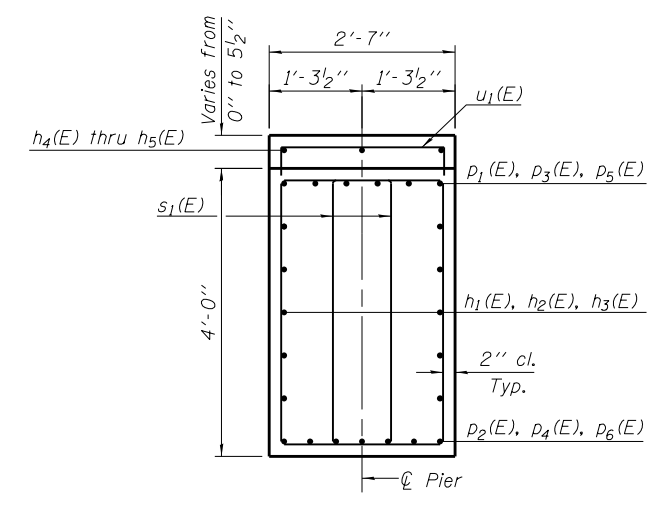

SECTION A-A

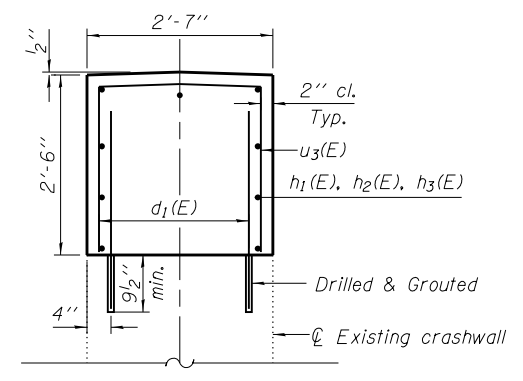

SECTION E-E

* The Location of the elevation at the top of crashwall shown in the Pier Elevation view.

**For Piers 1 & 4 only.

H:\projects\2014\0222\CAD\Structural\06-1149_Final\00\Di60J15-s46-pier-dt.dgn 3/27/2014 4:57:06 PM

USER NAME =	DESIGNED - J.Z.	REVISED -
CHECKED - J.A.Z.	REVISED -	
PLOT SCALE =	DRAWN - E.E.J.	REVISED -
PLOT DATE =	DATE - 3/31/2014	REVISED -

F.A.I. RTE.	SECTION	COUNTY	TOTAL SHEETS	SHEET NO.
94	1920-B	COOK	142	110
CONTRACT NO. 60J15				
ILLINOIS FED. AID PROJECT				