

EXISTING TYPICAL SECTION

- ROAD 6 STA 608+89 TO STA 611+17
- ROAD 6 STA 616+03 TO STA 616+90
- ROAD 6A STA 625+12 TO STA 626+40

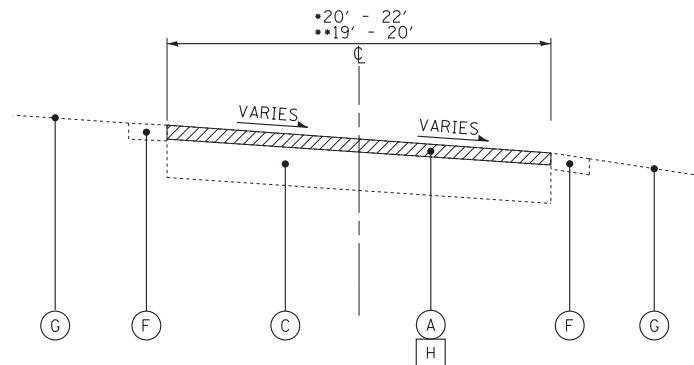

EXISTING TYPICAL SECTION

- ROAD 6 STA 611+17 TO STA 614+48
- ROAD 6 STA 616+90 TO STA 620+55

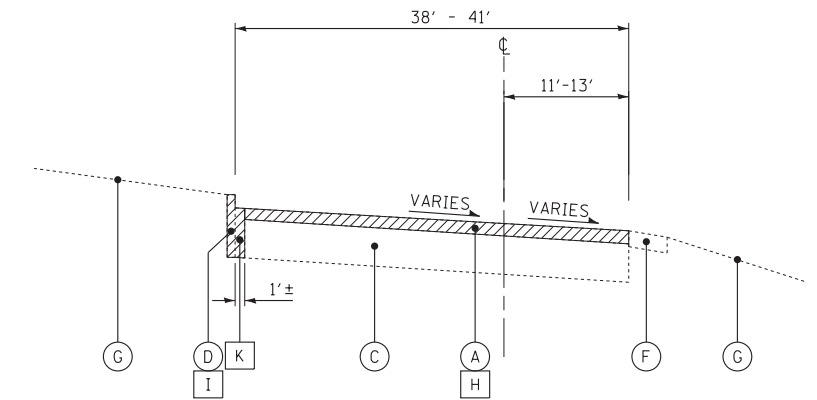

EXISTING TYPICAL SECTION

- ROAD 6 STA 614+48 TO STA 616+03

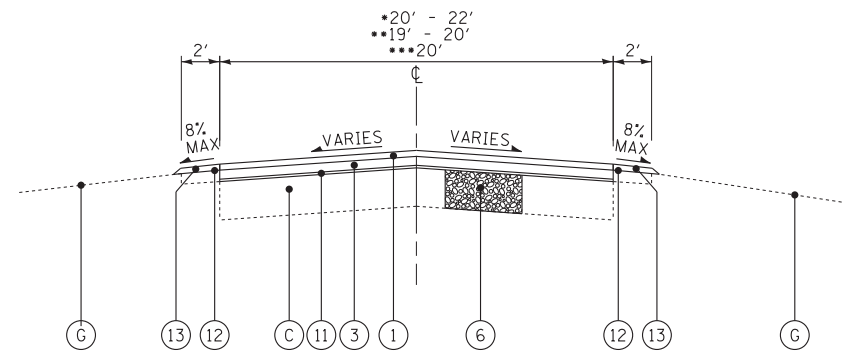

PROPOSED TYPICAL SECTION

- ROAD 6 STA 608+89 TO STA 611+17
- ROAD 6 STA 616+03 TO STA 616+90
- ROAD 6A STA 625+12 TO STA 626+40

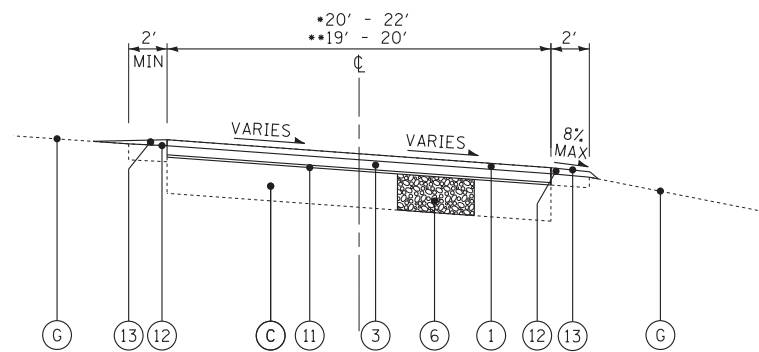

PROPOSED TYPICAL SECTION

- ROAD 6 STA 611+17 TO STA 614+48
- ROAD 6 STA 616+90 TO STA 620+55

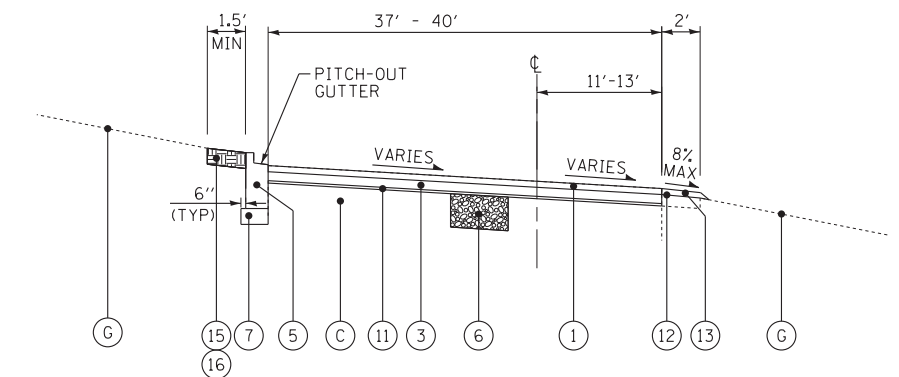

PROPOSED TYPICAL SECTION

- ROAD 6 STA 614+48 TO STA 616+03

EXISTING LEGEND

- (A) EXISTING HMA SURFACE - 2" - 3"
- (B) EXISTING PCC PAVEMENT - 8"±
- (C) EXISTING AGGREGATE BASE - 6" - 12"
- (D) EXISTING CURB
- (E) EXISTING CURB AND GUTTER
- (F) EXISTING AGGREGATE SHOULDER - 4"± (WHERE IT EXISTS)
- (G) EXISTING GROUND
- (H) HOT-MIX ASPHALT SURFACE REMOVAL - 3"
- (I) CURB REMOVAL
- (J) COMBINATION CURB AND GUTTER REMOVAL
- (K) PAVEMENT REMOVAL
- (Hatched) ITEM TO BE REMOVED

PROPOSED LEGEND

- (1) HOT-MIX ASPHALT SURFACE COURSE, MIX "D", N50 - 1 1/2"
- (2) HOT-MIX ASPHALT SURFACE COURSE, MIX "D", N50 - 2"
- (3) HOT-MIX ASPHALT BINDER COURSE, IL-19.0, N50 - 2 1/4"
- (4) LEVELING BINDER (MACHINE METHOD), N50 - 1"
- (5) COMBINATION CONCRETE CURB AND GUTTER, TYPE B-6.12
- (6) BASE COURSE REMOVAL (SPECIAL) AND AGGREGATE BASE COURSE, TYPE B (AS DETERMINED BY THE ENGINEER)
- (7) AGGREGATE BASE COURSE, TYPE B - 4"
- (8) CLASS D PATCHES - 8" (AS DETERMINED BY THE ENGINEER)
- (9) CLASS D PATCHES - 6"
- (10) CLASS D PATCHES - 3" (AS DETERMINED BY THE ENGINEER)
- (11) PREPARATION OF BASE
- (12) GRADING AND SHAPING SHOULDERS
- (13) AGGREGATE WEDGE SHOULDER, TYPE B
- (14) PORTLAND CEMENT CONCRETE SURFACE REMOVAL - BUTT JOINT
- (15) TOPSOIL FURNISH AND PLACE, 4"
- (16) SEEDING, CLASS 1A

COPYRIGHT © 2014 BY BAXTER & WOODMAN, INC.
 STATE OF ILLINOIS - PROFESSIONAL DESIGN FIRM
 LICENSE NO. - 184-00121 - EXPIRES 4/30/2015
 5/5/2014 5:56:00 PM
 I:\CrysalLaka\LDOT\40183-Vor\40\W0-1\CAADD\40183_W0-1-TypSect.dgn



DESIGNED - DSH	REVISED -
DRAWN - UKB	REVISED -
CHECKED - LDH	REVISED -
DATE - 05-06-14	FILE - 140183_W0-1-TypSect.dgn

**STATE OF ILLINOIS
DEPARTMENT OF TRANSPORTATION**

**ILLINOIS YOUTH CENTER - ST. CHARLES
EXISTING AND PROPOSED TYPICAL SECTIONS**

SCALE: NONE

STA. TO STA.

F.A. RTE.	SECTION	COUNTY	TOTAL SHEETS	SHEET NO.
347	2014-04RS	KANE	25	11
C-91-374-14		CONTRACT NO. 60Y37		
FED. ROAD DIST. NO. 1 ILLINOIS FED. AID PROJECT				