

EXISTING TYPICAL SECTION

- ROAD 7
 * ROAD 7 STA 700+10 TO STA 703+04
 ** ROAD 7 STA 703+04 TO STA 707+50

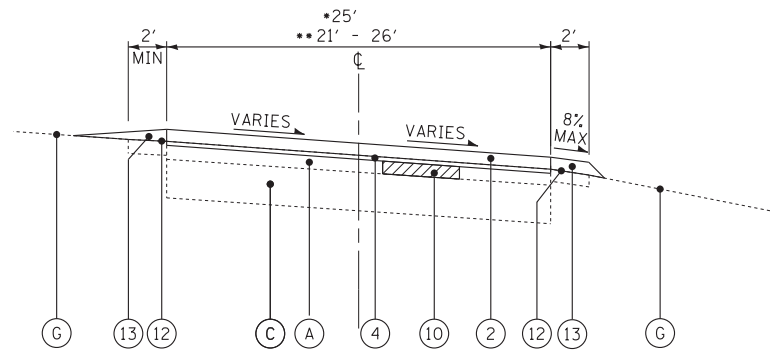

PROPOSED TYPICAL SECTION

- ROAD 7
 * ROAD 7 STA 700+10 TO STA 703+04
 ** ROAD 7 STA 703+04 TO STA 707+50

EXISTING LEGEND

- (A) EXISTING HMA SURFACE - 2" - 3"
- (B) EXISTING PCC PAVEMENT - 8"±
- (C) EXISTING AGGREGATE BASE - 6" - 12"
- (D) EXISTING CURB
- (E) EXISTING CURB AND GUTTER
- (F) EXISTING AGGREGATE SHOULDER - 4"± (WHERE IT EXISTS)
- (G) EXISTING GROUND
- (H) HOT-MIX ASPHALT SURFACE REMOVAL - 3"
- (I) CURB REMOVAL
- (J) COMBINATION CURB AND GUTTER REMOVAL
- (K) PAVEMENT REMOVAL
- [Hatched Box] ITEM TO BE REMOVED

PROPOSED LEGEND

- (1) HOT-MIX ASPHALT SURFACE COURSE, MIX "D", N50 - 1 1/2"
- (2) HOT-MIX ASPHALT SURFACE COURSE, MIX "D", N50 - 2"
- (3) HOT-MIX ASPHALT BINDER COURSE, IL-19.0, N50 - 2 1/4"
- (4) LEVELING BINDER (MACHINE METHOD), N50 - 1"
- (5) COMBINATION CONCRETE CURB AND GUTTER, TYPE B-6.12
- (6) BASE COURSE REMOVAL (SPECIAL) AND AGGREGATE BASE COURSE, TYPE B (AS DETERMINED BY THE ENGINEER)
- (7) AGGREGATE BASE COURSE, TYPE B - 4"
- (8) CLASS D PATCHES - 8" (AS DETERMINED BY THE ENGINEER)
- (9) CLASS D PATCHES - 6"
- (10) CLASS D PATCHES - 3" (AS DETERMINED BY THE ENGINEER)
- (11) PREPARATION OF BASE
- (12) GRADING AND SHAPING SHOULDERS
- (13) AGGREGATE WEDGE SHOULDER, TYPE B
- (14) PORTLAND CEMENT CONCRETE SURFACE REMOVAL - BUTT JOINT
- (15) TOPSOIL FURNISH AND PLACE, 4"
- (16) SEEDING, CLASS 1A

COPYRIGHT © 2014 BY BAXTER & WOODMAN, INC.
 STATE OF ILLINOIS - PROFESSIONAL DESIGN FIRM
 LICENSE NO. - 184-00121 - EXPIRES 4/30/2015
 5/5/2014 5:56:00 PM
 I:\CrysalLake\LDOT\40183-Vor\40\W0-1\CADD\40183_W0-1-TypSect.dgn

	DESIGNED - DSH	REVISED -
	DRAWN - UKB	REVISED -
	CHECKED - LDH	REVISED -
	DATE - 05-06-14	FILE - 140183_W0-1-TypSect.dgn

STATE OF ILLINOIS
DEPARTMENT OF TRANSPORTATION

ILLINOIS YOUTH CENTER - ST. CHARLES EXISTING AND PROPOSED TYPICAL SECTIONS		F.A. RTE. 347 SECTION 2014-04RS COUNTY KANE TOTAL SHEETS 25 SHEET NO. 12
SCALE: NONE	STA.	TO STA.

F.A. RTE. 347	SECTION 2014-04RS	COUNTY KANE	TOTAL SHEETS 25	SHEET NO. 12
C-91-374-14		CONTRACT NO. 60Y37		
FED. ROAD DIST. NO. 1 ILLINOIS FED. AID PROJECT				