

**PLAN VIEW**  
**APPROACH SLAB OR BRIDGE APPROACH SHOULDER**  
 (STANDARD 609001 or 609006)

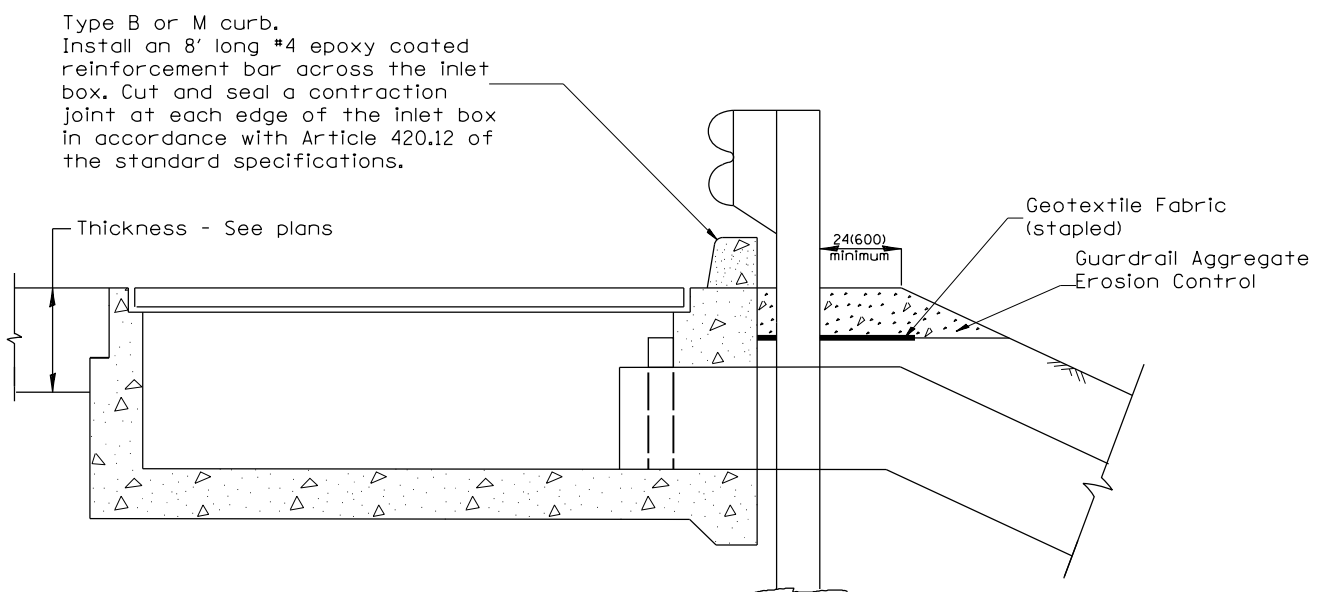

**TYPICAL SECTION AT INLETS**  
**TYPE E & F (STANDARD 610001)**

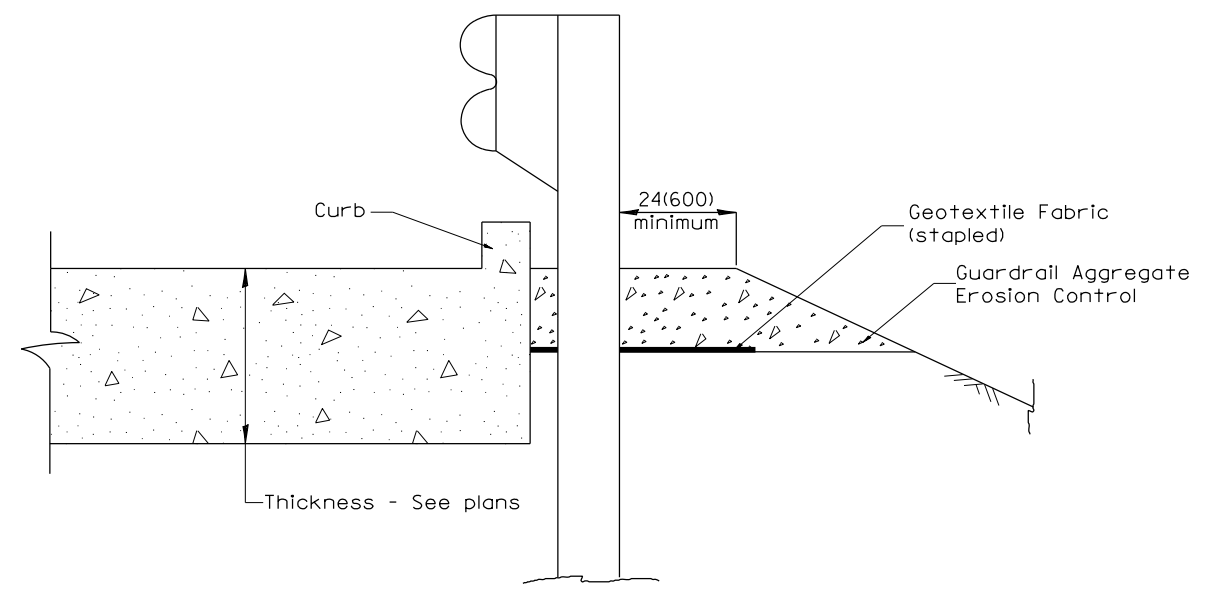

**SECTION A-A**  
**TYPICAL SECTION WITH BRIDGE APPROACH CURB**

All dimensions are in inches (millimeters) unless otherwise noted.

FILE NAME =	USER NAME = bemery	DESIGNED -	REVISED -	<b>STATE OF ILLINOIS</b> <b>DEPARTMENT OF TRANSPORTATION</b>	<b>GUARDRAIL EROSION CONTROL TREATMENTS</b> <b>IL 8 OVER KICKAPOO CREEK</b>	F.A.S. RTE.	SECTION	COUNTY	TOTAL SHEETS	SHEET NO.	
P:\Projects\2008 Projects\08379 IL 8 over Kickapoo Creek\CADD Sheets\0468697-sheet.DRAWN.dgn		CHECKED -	REVISED -			1388	(Z-ID-BR-1)BR	PEORIA	89	39	
Default	PLOT SCALE = 100.0000' / 1in.	DATE -	REVISED -			SHT. 2 OF 2 CADD STD. 630101-D4					
	PLOT DATE = 3/20/2014					CONTRACT NO. 68697					