

**STAGE I REMOVAL**

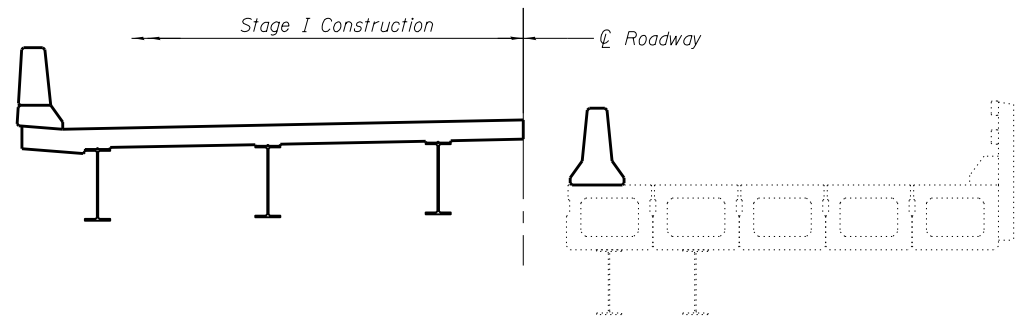

**STAGE I CONSTRUCTION**

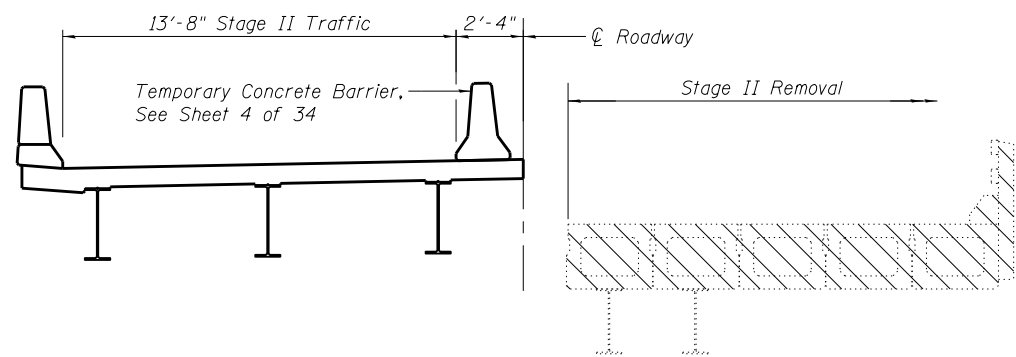

**STAGE II REMOVAL**

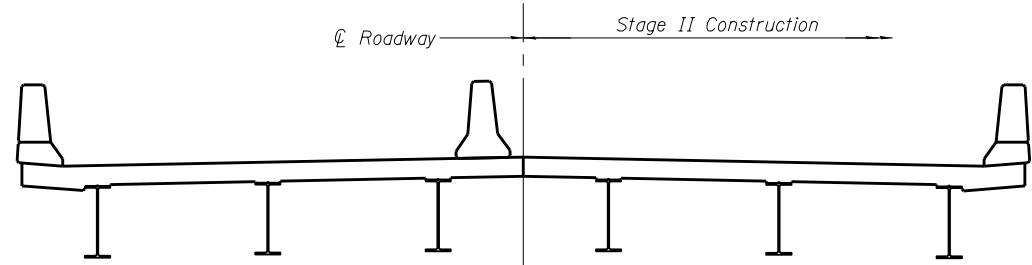

**STAGE II CONSTRUCTION**

\* Temporary support beams to be removed and salvaged. Cost included with Removal of Existing Structures.

**Notes:**

The Contractor shall connect the first sheet to the existing abutment wall to ensure stability of sheets driven to the top of the existing footing. This connection shall be reviewed and accepted by the Engineer and included in the cost for Temporary Sheet Piling.  
If the Contractor chooses to alter the temporary cantilevered sheet piling design requirements shown on the plans, a design submittal including plan details and calculations will be required for review and acceptance by the Engineer.

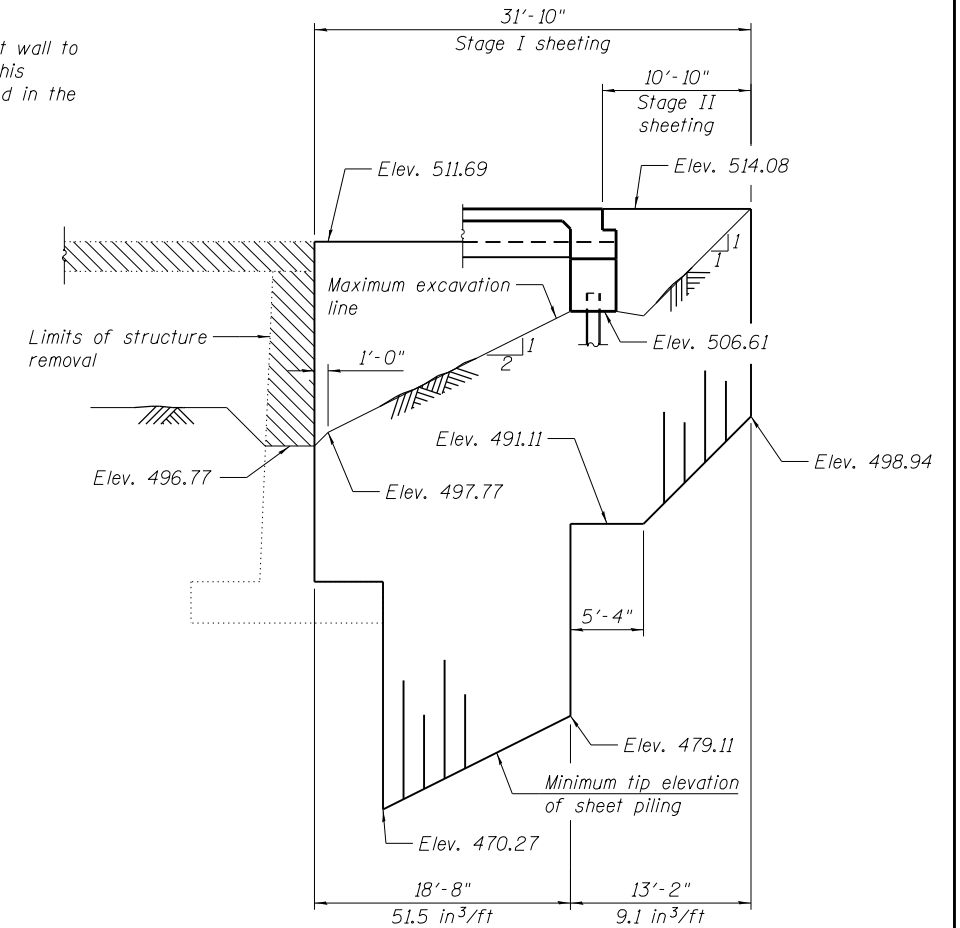

**TEMPORARY SHEET PILING AT EAST ABUTMENT**

**Notes:**

All staging cross sections are looking East. For quantity of Temporary Concrete Barrier, see roadway plans. Hatched area indicates Removal of Existing Structures.

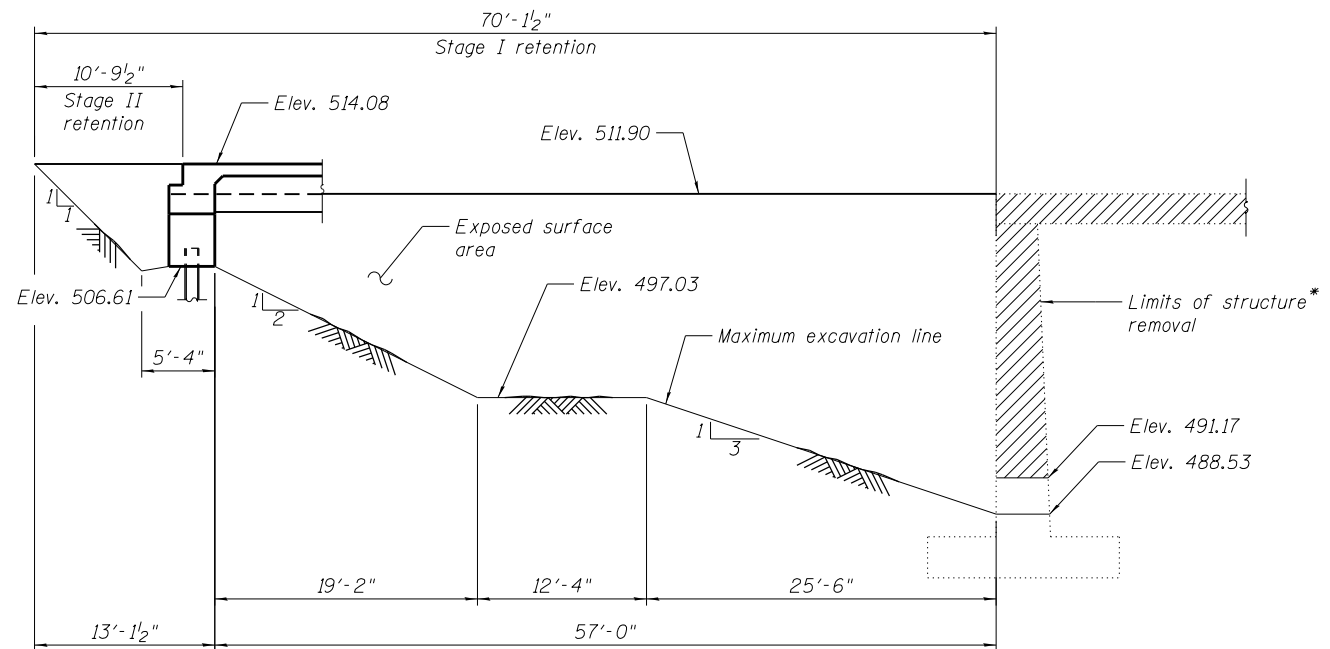

**TEMPORARY SOIL RETENTION AT WEST ABUTMENT**

**Note:**

A cantilevered sheet piling design does not appear feasible and additional members or other retention systems may be necessary. The Contractor shall submit a temporary soil retention system design including plan details and calculations for review and acceptance by the Engineer.

\* Existing reinforcement shall be cut off flush with the surface to which the old concrete has been removed.

FILE NAME = 0720229-68697-003-Stg Const Details.dgn	USER NAME =	DESIGNED - BWP	REVISED -	<b>STATE OF ILLINOIS DEPARTMENT OF TRANSPORTATION</b>	<b>STAGE CONSTRUCTION DETAILS STRUCTURE NO. 072-0229</b>	F.A.S. RTE. 1388	SECTION (Z-1D-BR-1)BR	COUNTY PEORIA	TOTAL SHEETS 89	SHEET NO. 45	
BACON   FARMER   WORKMAN ENGINEERING & TESTING, INC. 433 NORTH COURT STREET MARIETTA, IL 62428 PHONE: 618.997.9100	PLOT SCALE =	CHECKED - CMV	REVISED -			<b>CONTRACT NO. 68697</b>					
PLOT DATE = 3/18/2014		DRAWN - BJV	REVISED -			ILLINOIS FED. AID PROJECT					
		CHECKED - CMV	REVISED -			SHEET NO. 3 OF 34 SHEETS					