

PLAN

All beams are W30x124, AASHTO M270 Grade 50 (NTR).

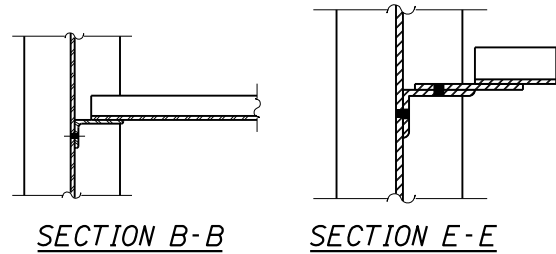

SECTION B-B SECTION E-E

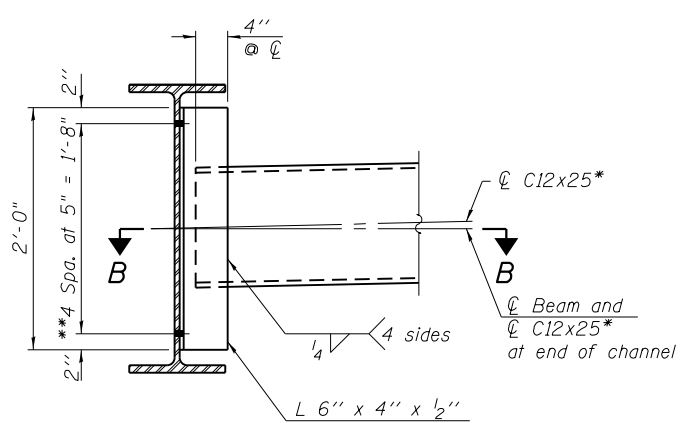

DIAPHRAGM D

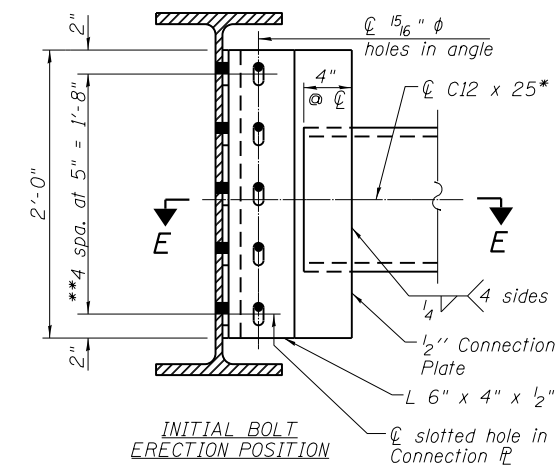

INITIAL BOLT ERECTION POSITION

Note:
 Two hardened washers required for each set of oversized holes.
 *Alternate channel C12x30 is permitted to facilitate material acquisition. Calculated weight of structural steel is based on the lighter section. The alternate, if utilized, shall be provided at no additional cost to the Department.
 ***3/4" φ HS bolts, 15/16" φ holes

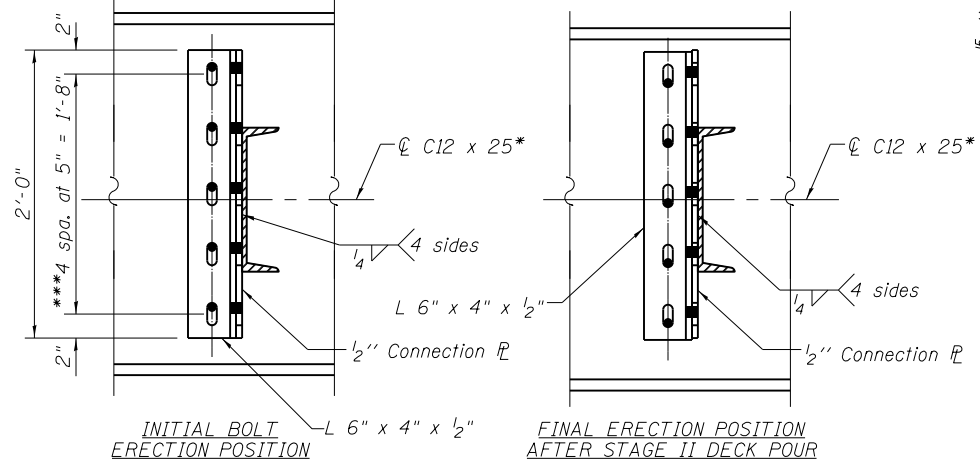

INITIAL BOLT ERECTION POSITION

FINAL ERECTION POSITION AFTER STAGE II DECK POUR

DIAPHRAGM D (North Side Beam 4)
 ***3/4" φ HS bolts, on the North side of Beam 4 provide 13/16" x 1 7/8" vertical slotted holes in the angle at the web and in the connection plate. Bolts in slotted holes shall be finger tightened until the second stage pour is completed. Position slots so bolts move from one end with no concrete load to the opposite end under the deck load. The slotted holes in the angle and connection plate shall be positioned as shown to allow the bolts to move to the final erection positions under deck load. The holes shall be positioned to allow maximum bolt displacement without laterally stressing the girders.

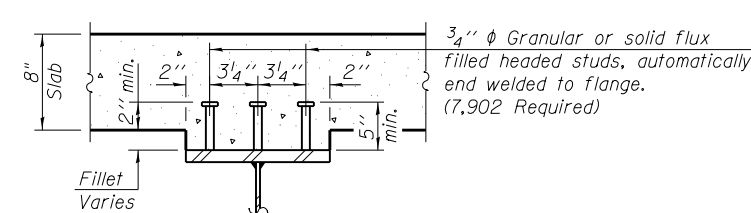

SECTION A-A

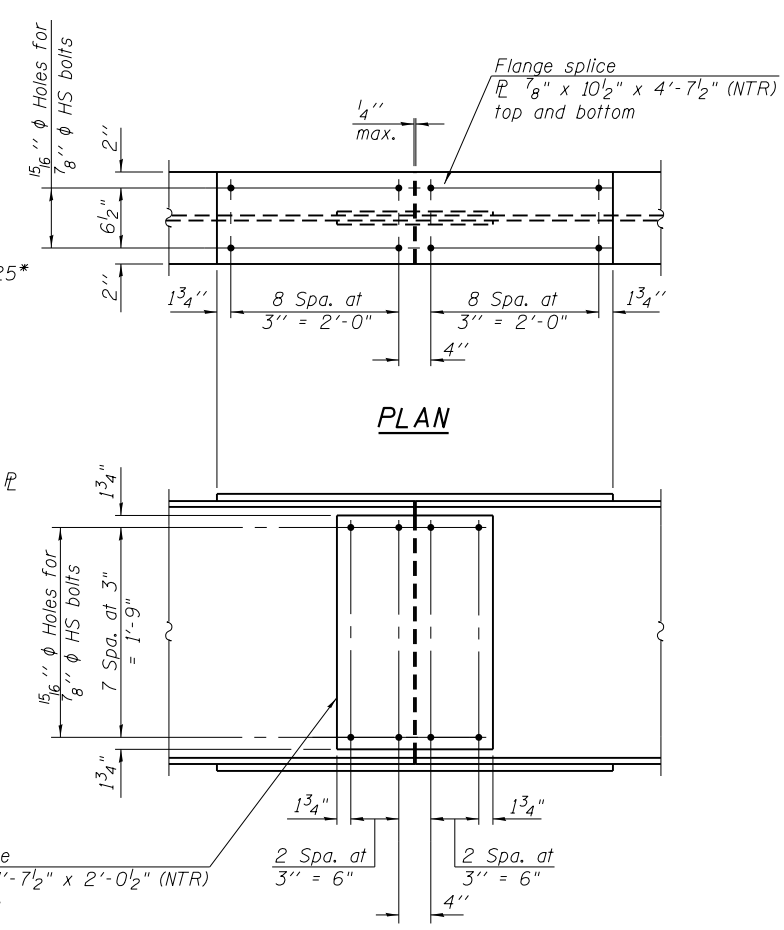

PLAN

ELEVATION

SPlice DETAIL (36 Required)

All diaphragms shall be installed as steel is erected and secured with erection pins and bolts except as otherwise noted. Individual cross frames or diaphragms at supports may be temporarily disconnected to install bearing anchor rods.

Load carrying components designated "NTR" shall conform to the Impact Testing Requirement, Zone 2.

All web and flange splice plates shall be AASHTO M270, Grade 50.

FILE NAME = 0720229-68697-019-Structural Steel.dgn	USER NAME =	DESIGNED - BWP	REVISED -	STATE OF ILLINOIS DEPARTMENT OF TRANSPORTATION	STRUCTURAL STEEL STRUCTURE NO. 072-0229	F.A.S. RT.E.	SECTION	COUNTY	TOTAL SHEETS	SHEET NO.	
BACON FARMER WORKMAN ENGINEERING & TESTING, INC.	PLOT SCALE =	CHECKED - CMV	REVISED -			1388	(Z-1D-BR-1)BR	PEORIA	89	61	
433 NORTH COURT STREET MARIETTA, IL 61751-0097 PHONE - 815/977-9190	PLOT DATE = 3/18/2014	DRAWN - BJV	REVISED -			CONTRACT NO. 68697					
		CHECKED - BWP	REVISED -			ILLINOIS FED. AID PROJECT					