

EXISTING TYPICAL SECTION F.A.I. 39 3

C.H. 12 INTERCHANGE RAMPS

RAMP	STATION	TO	STATION
RAMP A	0+00.00		7+70.00
RAMP B	11+68.00		27+47.27
RAMP C	0+00.00		7+73.00
RAMP D	10+38.00		23+95.61

C.H. 8 INTERCHANGE RAMPS

RAMP	STATION	TO	STATION
RAMP A	0+00.00		7+03.00
RAMP B	9+31.00		22+00.00
RAMP C	0+00.00		7+73.00
RAMP D	8+28.00		21+04.00

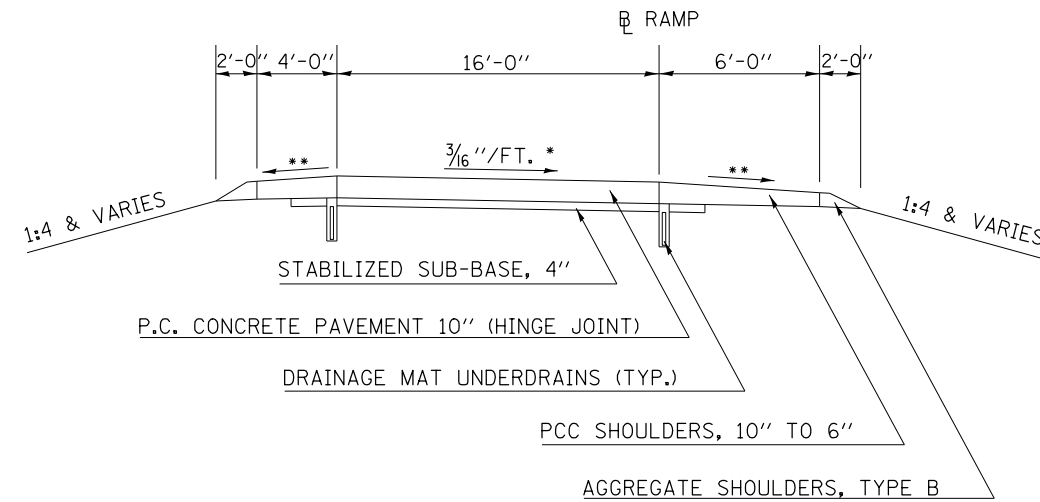

PROPOSED TYPICAL SECTION F.A.I. 39 3

C.H. 12 INTERCHANGE RAMPS

RAMP	STATION	TO	STATION
RAMP A	0+00.00		7+70.00
RAMP B	11+68.00		27+47.27
RAMP C	0+00.00		7+73.00
RAMP D	10+38.00		23+95.61

C.H. 8 INTERCHANGE RAMPS

RAMP	STATION	TO	STATION
RAMP A	0+00.00		7+03.00
RAMP B	9+31.00		22+00.00
RAMP C	0+00.00		7+73.00
RAMP D	8+28.00		21+04.00

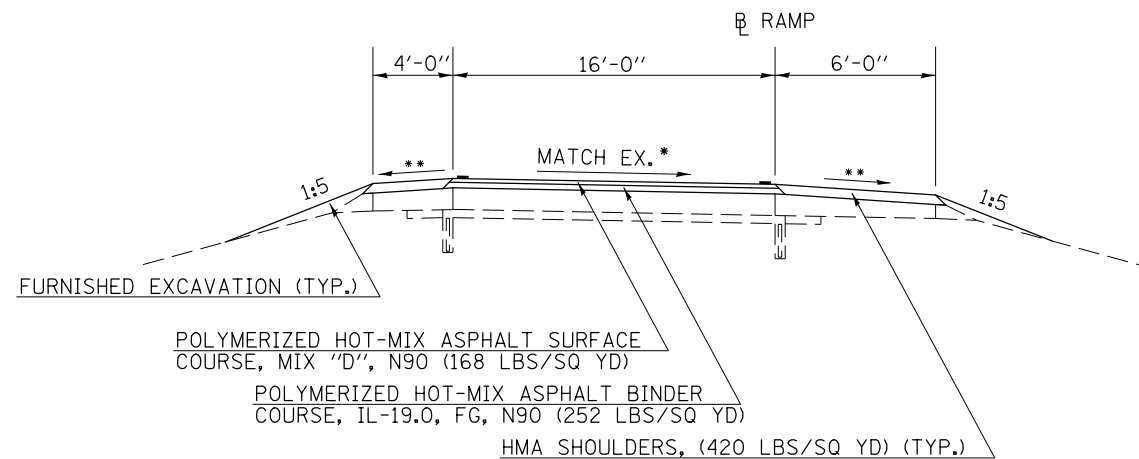

* SLOPE VARIES FOR SUPERELEVATION IN CURVES

** SLOPE VARIES IN SUPERELEVATION WITH MAXIMUM OF 0.08 FT/FT DIFFERENCE

FILE NAME =	USER NAME = bergana.j	DESIGNED -	REVISED -	STATE OF ILLINOIS DEPARTMENT OF TRANSPORTATION	TYPICAL SECTIONS	F.A.I. RTE. 39	SECTION (57-3,57-4)RS	COUNTY MCLEAN	TOTAL SHEETS 94	SHEET NO. 15
et:\p\work\p\dot\bergana.j\0373914\057391420-SHT-TYPICAL.dgn		DRAWN -	REVISED -							
	PLOT SCALE = 40.0000' / in.	CHECKED -	REVISED -							
#MODELNAME#	PLOT DATE = 3/18/2014	DATE -	REVISED -		SCALE:	SHEET 3	OF 3 SHEETS	STA.	TO STA.	ILLINOIS FED. AID PROJECT

CONTRACT NO. 70A20