

DETAIL FOR I-39 BUTT JOINTS AND PAVING TRANSITIONS

DEPARTURE SN 057-0209

(A)	NORTHBOUND	(B)
STATION	TO	STATION
306+01.00		306+35.80 (BK)
305+66.49 (AH)		306+50.19

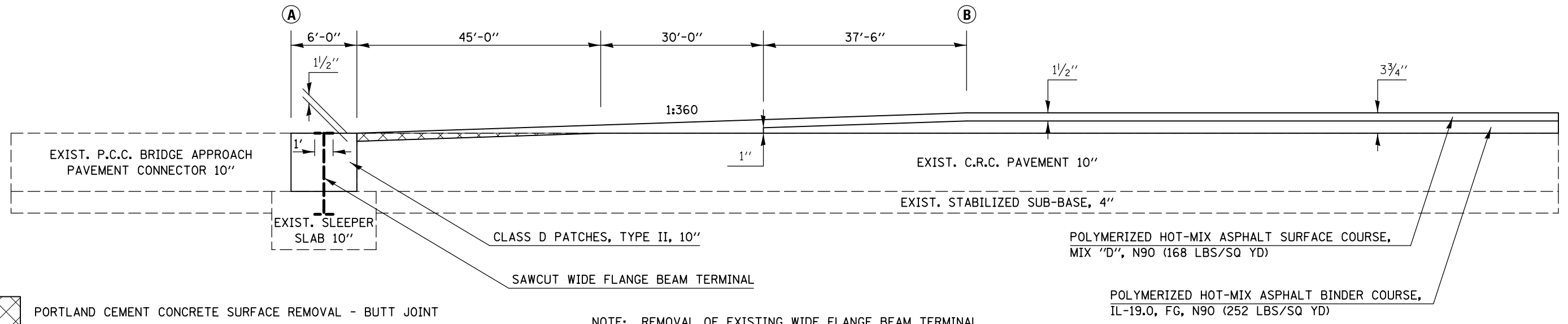

NOTE: REMOVAL OF EXISTING WIDE FLANGE BEAM TERMINAL SHALL BE INCLUDED IN THE COST OF CLASS D PATCHES

DETAIL FOR I-39 SHOULDER BUTT JOINTS AND PAVING TRANSITIONS

DEPARTURE SN 057-0209

(A)	NORTHBOUND	(B)
STATION	TO	STATION
306+01.00		306+35.80 (BK)
305+66.49 (AH)		306+50.19

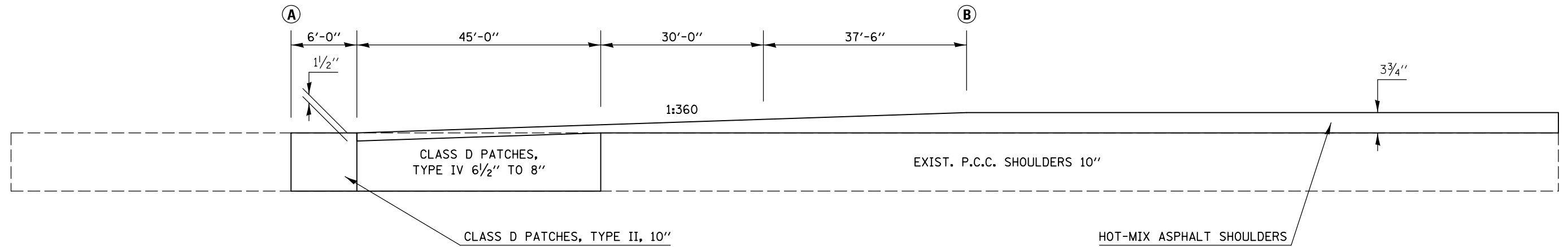

NOTE: CLASS D PATCHES, TYPE IV, 6 1/2" TO 8" SHALL BE PAID FOR AS CLASS D PATCHES, TYPE IV, 8"

FILE NAME =	USER NAME = bergenej	DESIGNED -	REVISED -	STATE OF ILLINOIS DEPARTMENT OF TRANSPORTATION	MILLING AND PAVING TRANSITION DETAILS	F.A.I. RTE.	SECTION	COUNTY	TOTAL SHEETS	SHEET NO.
ci:\pw\work\p\dot\bergenej\d0373914\0570A20-SHT-DETAILS.dgn	DRAWN -	REVISED -	39			(57-3,57-4)RS	MCLEAN	94	42	
PLOT SCALE = 40.0000' / in.	CHECKED -	REVISED -	CONTRACT NO. 70A20							
#MODELNAME#	DATE -	REVISED -	ILLINOIS FED. AID PROJECT							