

PLACE THE ARROW 18' (5.5 m) BACK FROM STOP BAR  
 PLACE ANOTHER ARROW EVEN WITH THE BEGINNING  
 OF THE SOLID WHITE LINE. SPACE ADDITIONAL ARROWS  
 EVENLY UP TO 80' (24.4 m) MAXIMUM SPACING.

\* REDUCE TO 40 FEET (12.2 METERS) SPACING ON CURVES  
 WHERE ADVISORY SPEEDS ARE 10 MPH (15 km/h) LOWER  
 THAN POSTED SPEEDS.

\*\* DOUBLE LANE LINE MARKERS SHALL BE SPECIFIED  
 AND SPACED AS SHOWN IN HIGHWAY STANDARD  
 781001 FOR MULTI-LANE DIVIDED AND UNDIVIDED  
 HIGHWAYS.

**PAVEMENT MARKING LEGEND**

- 1 4" (100) SKIP-DASH (YELLOW)
- 2 4" (100) SOLID (YELLOW)
- 3 12" (300) DIAGONAL (YELLOW)
- 4 4" (100) DOUBLE YELLOW (NARROW)
- 5 12" (300) SOLID WHITE
- 6 RESERVED
- 7 6" (150) SKIP-DASH (WHITE)
- 8 4" (100) SOLID (WHITE)
- 9 12" (300) DIAGONAL (WHITE)
- 10 6" (150) SOLID (WHITE)
- 11 24" (600) STOP BAR (WHITE)
- 12 8" (200) SOLID (WHITE)
- 13 4" (100) PARKING WHITE

**GENERAL NOTES**

1. TURN ARROW PAIRS SHALL BE PLACED AT 250' (75 m) INTERVALS AND SHALL BE EVENLY SPACED BETWEEN BOTH ENDS OF THE BIDIRECTIONAL LEFT TURN LANE. USE A MINIMUM OF TWO PAIRS PER BLOCK.
2. THE SOLID YELLOW PAVEMENT MARKINGS [2] SHOULD GENERALLY START OR END NEAR THE RADIUS POINT OF EACH STREET RETURN EXCEPT WHERE ONE OR BOTH ENDS WOULD INCLUDE STOP BARS.
3. THE SKIP-DASH PAVEMENT MARKINGS [1] OR [7] SHOULD BE CENTERED BETWEEN BOTH ENDS OF EACH CITY BLOCK AND SHALL BE PLACED SO THEY LINE UP ACROSS FROM EACH OTHER.
4. USE LARGE ARROW SIZE FOR BOTH RURAL AND URBAN LOCATIONS. (SEE LAST PAGE OF SECTION 780x FOR SYMBOLS TABLE)
5. LANE LINE EXTENSIONS SHALL BE THE SAME COLOR AND WIDTH AS THE LANE LINE BEING EXTENDED.

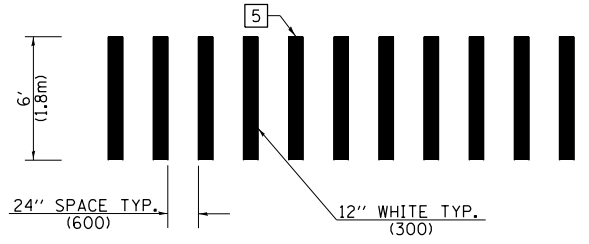

**CROSSWALK DETAIL  
 (DECATUR CITY LIMITS ONLY)**

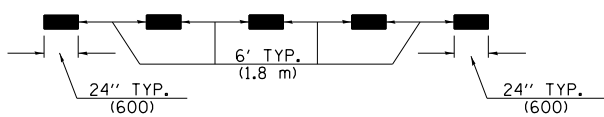

**LANE LINE EXTENSIONS**

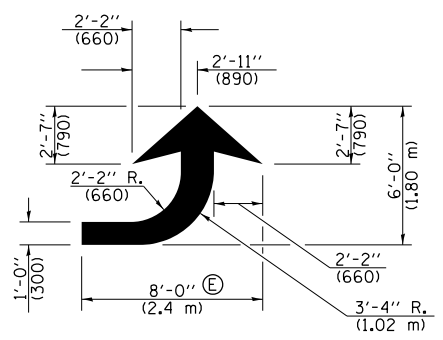

**LEFT ARROW**

REVERSE FOR RIGHT ARROW  
 AREA = 15.6 SQ. FT. (1.47 m<sup>2</sup>)  
 (WHITE)

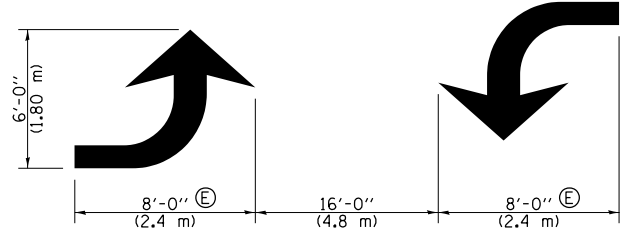

**TYPICAL DOUBLE  
 TURN ARROWS (WHITE)**

NOT TO SCALE  
 Note: All dimensions are in INCHES  
 (millimeters) unless otherwise shown.

**DISTRICT 7 DETAIL NO. 7800001**

|  |                               |            |           |   |   |  |  |             |              |          |              |           |
|--|-------------------------------|------------|-----------|---|---|--|--|-------------|--------------|----------|--------------|-----------|
| FILE NAME =  | USER NAME = steffenmk         | DESIGNED - | REVISED - | <b>STATE OF ILLINOIS<br/>DEPARTMENT OF TRANSPORTATION</b> | <b>PAVEMENT MARKING AND RAISED REFLECTIVE PAVEMENT MARKERS<br/>(RURAL &amp; URBAN APPLICATIONS)</b> |  |  | F.A.P. RTE. | SECTION      | COUNTY   | TOTAL SHEETS | SHEET NO. |
| ei:\pw\work\p\idot\steffenmk\d0282300\074554-sht-details.dgn | PLOT SCALE = 100.0000' / 1" = | DRAWN -    | REVISED - |   |   |  |  | 781         | (12,172RS-1) | CRAWFORD | 60           | 58        |
|  | PLOT DATE = 4/5/2013          | CHECKED -  | REVISED - |   | CONTRACT NO. 74554  |  |  |             |              |          |              |           |
|  |                               | DATE -     | REVISED - |   | ILLINOIS FED. AID PROJECT   |  |  |             |              |          |              |           |