

MAIN SPAN ELEVATION

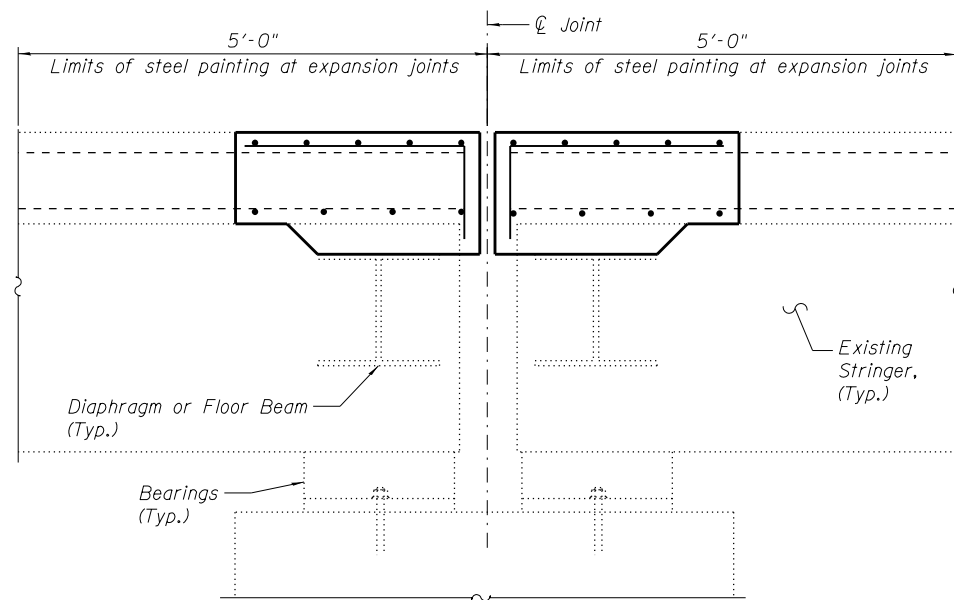

CROSS SECTION AT TYPICAL EXPANSION JOINT
(Joint at diaphragm shown, Joint at floorbeam similar)

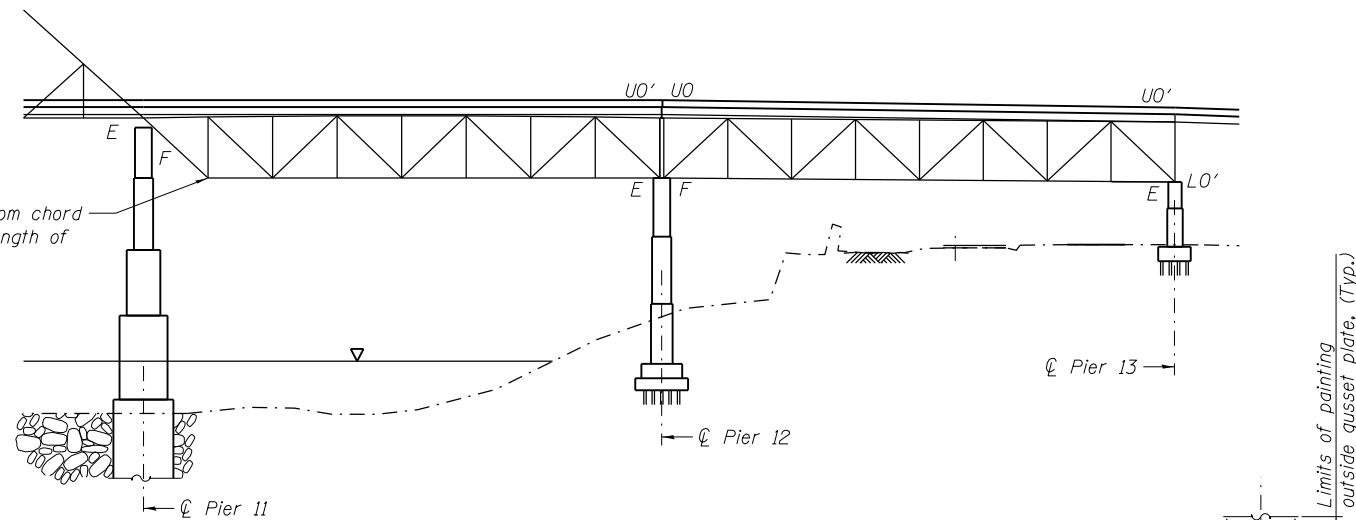

DECK TRUSS ELEVATION

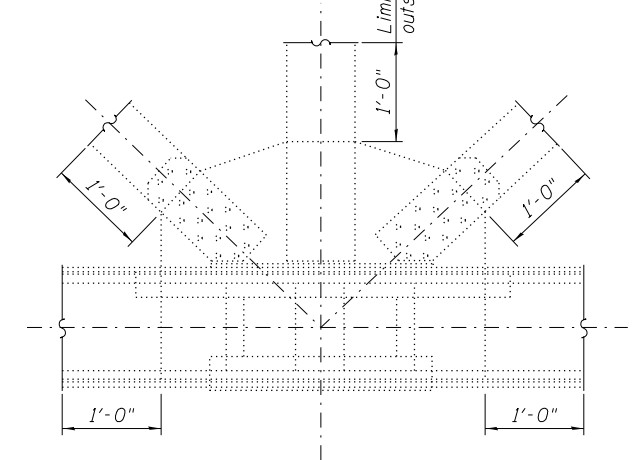

TYPICAL DECK TRUSS GUSSET PLATE

Notes:

- All steel members underneath the deck that are to remain shall be cleaned and painted within 5 ft from any deck joint (including deck relief joints throughout the main spans).
- The entire wind transfer device between PP 21' and PP 23', shall be cleaned and painted including all attachments to other members. See existing 1987 rehabilitation plans for details.
- Clean and paint the bottom truss chord and splash zone on each side of the main spans. This shall include all surfaces of each member including inside the bottom chord. All truss members shall be painted up to the height of 15 ft from the bottom of the bottom truss chord on each side of the deck. The floor beam end connections to the bottom chord, the end of 5 ft of each floor beam, the exterior stringer connections to the floor beams, and the end of 5 ft of each exterior stringer shall also be cleaned and painted.
- Clean and paint all bottom chord gusset plates, including members within the joint to a distance 1 ft beyond the limits of the gusset plates, throughout the limits of the deck truss spans.
- Clean and paint the end 8 ft of Stringer 1 on span 19 at Bent 18.
- The Contractor shall match the color of the final finish coat for all steel surfaces to the existing paint color on the structure.

- The existing structural steel coating contains lead. The Contractor shall take appropriate precautions to deal with the presence of lead on this project as specified in the special provision for Containment and Disposal of Lead Paint Cleaning Residues.
- Cleaning and painting of the existing structural steel shall be as specified in the special provision for Cleaning and Painting Existing Steel Structures.
- Complete cost of painting the locations described on this sheet shall be considered included with the pay item Cleaning and Painting Steel Bridge No. 1.
- Cleaning of existing structural steel in the areas of structural repairs or new structural installations shall be as specified in the special provision for Cleaning and Painting Contact Surface Areas of Existing Steel Structures.
- Calendar date painting restrictions will be waived for this project. See special provisions.
- Complete cost of painting repair areas shown throughout the plans shall be considered included with the pay item Structural Steel Repair.
- The removal and disposal of the existing lead paint shall be considered included with the pay item Containment and Disposal of Lead Paint Cleaning Residues No. 1.

BILL OF MATERIAL

Item	Unit	Total
Cleaning and Painting Steel Bridge No. 1	L Sum	1
Containment and Disposal of Lead Paint Cleaning Residues No. 1	L Sum	1