

STATE OF ILLINOIS  
DEPARTMENT OF TRANSPORTATION  
DIVISION OF HIGHWAYS

**PROPOSED  
HIGHWAY PLANS**

FAP ROUTE 869 (IL 34)  
SECTION 101RS-6

3P RESURFACING AND PATCHING  
FRANKLIN COUNTY

C-99-009-14

F.A.P. RTE.	SECTION	COUNTY	TOTAL SHEETS	SHEET NO.
869	101RS-6	FRANKLIN	13	1
		ILLINOIS	CONTRACT NO. 78388	

FOR INDEX OF SHEETS, SEE SHEET NO. 2

**TRAFFIC DATA**

IL 34: 2014 ADT = 4790 WITH 7.5% TRUCKS  
2034 ADT = 5850 WITH 7.5% TRUCKS

**TOWNSHIPS**

BENTON

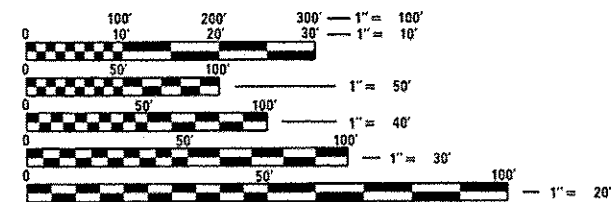
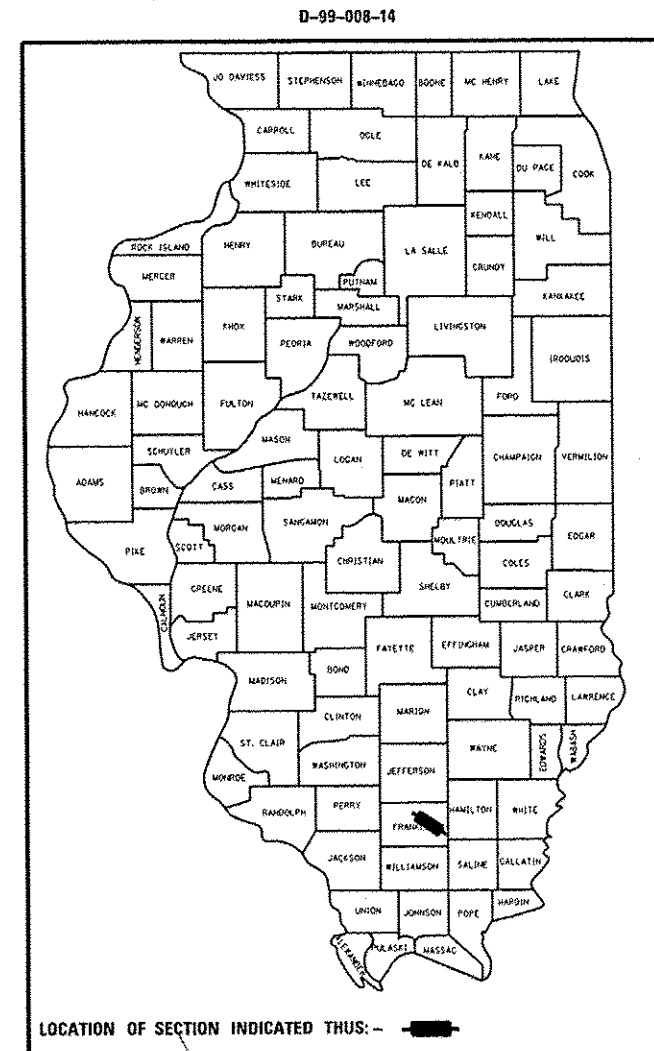

FULL SIZE PLANS HAVE BEEN PREPARED USING STANDARD ENGINEERING SCALES. REDUCED SIZED PLANS WILL NOT CONFORM TO STANDARD SCALES. IN MAKING MEASUREMENTS ON REDUCED PLANS, THE ABOVE SCALES MAY BE USED.

J.U.L.I.E.  
JOINT UTILITY LOCATION INFORMATION FOR EXCAVATION  
1-800-892-0123  
OR 811

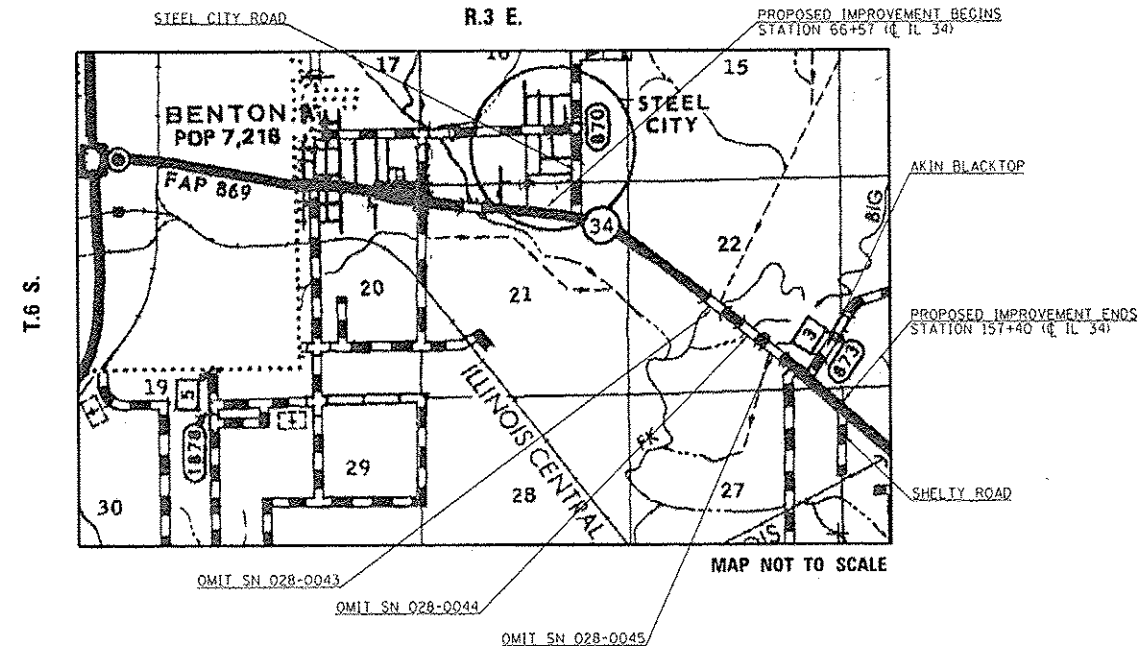

PROJECT ENGINEER: CHARLES STEIN  
PROJECT MANAGER: PAULA STOVER

CONTRACT NO. 78388

GROSS LENGTH = 9083 FT. = 1.72 MILE  
NET LENGTH = 8681 FT. = 1.64 MILE

STATE OF ILLINOIS  
DEPARTMENT OF TRANSPORTATION  
DIVISION OF HIGHWAYS

SUBMITTED *March 20, 2014*

*Jeffrey L. Keim*  
DEPUTY DIRECTOR OF HIGHWAYS, REGION ENGINEER

*May 9, 2014*  
*John D. Baranzelli, PE, Inc.*  
ENGINEER OF DESIGN AND ENVIRONMENT

*May 9, 2014*  
*Osman, PE, Inc.*  
DIRECTOR OF HIGHWAYS, CHIEF ENGINEER

**PRINTED BY THE AUTHORITY  
OF THE STATE OF ILLINOIS**

## INDEX OF SHEETS

SHT NO.	DESCRIPTION
1	COVER SHEET
2	INDEX OF SHEETS, STANDARDS, AND STRUCTURES
3	SIGNATURE SHEET
4	GENERAL NOTES, COMMITMENTS, AND MIX DESIGN
5	SUMMARY OF QUANTITIES
6	TYPICAL SECTIONS - IL 34
7-9	SCHEDULES OF QUANTITIES
10	DETAILS: SIDEROADS AND ENTRANCES
11	DETAILS: TEMPORARY RAMP AND BUTT JOINTS
12	DETAILS: MILLING TAPER
13	DETAILS: TEMPORARY HOT-MIX ASPHALT TRANSITIONS, UNEVEN LANES SIGN, ROUGH GROOVED SURFACE SIGN

## STANDARDS

000001-06  
001006  
001001-02  
442201-03  
701006-05  
701011-04  
701301-04  
701306-03  
701311-03  
701336-06  
701901-03  
780001-04

## STRUCTURES WITHIN PROJECT LIMITS

STRUCTURE NUMBER	OPERATING RATING	INVENTORY RATING	POSTING	MTD APPROVAL
028-0043	2.750	1.700	NONE	TBD
028-0044	1.825	1.095	NONE	TBD
028-0045	1.145	1.910	NONE	TBD

FILE NAME *	USER NAME * Heger-TA	DESIGNED - _____	REVISED - _____	<b>STATE OF ILLINOIS DEPARTMENT OF TRANSPORTATION</b>	<b>INDEX OF SHEETS, STANDARDS, AND STRUCTURES</b>	F.A.P. RTE.	SECTION	COUNTY	TOTAL SHEETS	SHEET NO.	
o:\pwork\pwork\meyer ta\0362583\0362583.dgn	CAOD.dgn	DRAWN - _____	REVISED - _____			869	101RS-6	FRANKLIN	13	2	
#MODELNAME*	PLOT SCALE = 5000.0004 1/16"	CHECKED - _____	REVISED - _____			CONTRACT NO. 78388					
	PLOT DATE = 3/26/2014	DATE - _____	REVISED - _____			ILLINOIS FED. AID PROJECT					
					SCALE: _____	SHEET _____ OF _____ SHEETS		STA. _____ TO STA. _____			

Prepared By: *Joe Zdaniewicz*  
DISTRICT STUDIES & PLANS ENGINEER

Examined By: *John E.*  
DISTRICT LAND ACQUISITION ENGINEER

Examined By: *Carrie Miller*  
DISTRICT PROGRAM DEVELOPMENT ENGINEER

Examined By: *Keel M.*  
DISTRICT OPERATIONS ENGINEER

Examined By: *[Signature]*  
DISTRICT PROJECT IMPLEMENTATION ENGINEER

Examined By: *Dwight J. [Signature]*  
DISTRICT CONSTRUCTION ENGINEER

Examined By: *[Signature]*  
DISTRICT MATERIALS ENGINEER

FILE NAME *	USER NAME = Mayer TA	DESIGNED - _____	REVISED - _____	<b>STATE OF ILLINOIS DEPARTMENT OF TRANSPORTATION</b>	<b>SIGNATURE SHEET</b>		F.A.P. RTE.	SECTION	COUNTY	TOTAL SHEETS	SHEET NO.	
c:\pwork\pctdas\mayer ta\d8362583\01x	CGDD.dgn	DRAWN - _____	REVISED - _____		869	10RS-6	FRANKLIN	13	3			
*MODEL NAME *	PLOT SCALE = 5280.0001 * / 12.	CHECKED - _____	REVISED - _____		SCALE: _____	SHEET _____	OF _____	SHEETS	STA. _____	TO STA. _____	ILLINOIS FED. AID PROJECT	CONTRACT NO. 78388
	PLOT DATE = 3/20/2014	DATE - _____	REVISED - _____									

## GENERAL NOTES

THE THICKNESS OF HOT-MIX ASPHALT SHOWN ON THE PLANS IS THE NOMINAL THICKNESS. DEVIATIONS FROM THE NOMINAL THICKNESS WILL BE PERMITTED WHEN SUCH DEVIATIONS OCCUR DUE TO IRREGULARITIES IN THE EXISTING SURFACE OR BASE ON WHICH THE HOT-MIX ASPHALT MIXTURE IS PLACED.

FACTORS USED FOR ESTIMATING PLAN QUANTITIES ARE AS FOLLOWS AND SHALL NOT BE USED FOR THE BASIS OF FINAL QUANTITIES:

ALL HOT-MIX ASPHALT	2.016 TONS / CU YD
ALL AGGREGATE	2.05 TONS / CU YD
BITUMINOUS MATERIALS: ON PAVEMENT	0.05 POUND / SQ YD

QUANTITIES SHOWN IN THE PLANS FOR PATCHING ARE ESTIMATES. THE ACTUAL AMOUNT OF PATCHING REQUIRED SHALL BE DETERMINED BY THE ENGINEER.

THE QUANTITY OF SHORT TERM PAVEMENT MARKING SHOWN IN THE PLANS IS BASED ON ONE APPLICATION EACH FOR THE SURFACE REMOVAL, SURFACE COURSE, AND BINDER COURSE.

IF EXISTING SUB-BASE IS INADEQUATE, AS DETERMINED BY THE ENGINEER, THE SIDE ROADS SHALL BE CORED OUT AND AGGREGATE SUB-BASE, TYPE B SHALL BE PLACED FOR BASE. THE COST OF CORING OUT THE SIDE ROAD SHALL BE INCLUDED IN THE COST OF THE AGGREGATE BASE COURSE. IF EXISTING SUB-BASE IS DETERMINED TO BE ADEQUATE, THE AGGREGATE BASE COURSE SHALL BE DELETED AND THE PREPARATION OF THE BASE SHALL BE CONSTRUCTED ACCORDING TO ARTICLE 406.09.

THE QUANTITY SHOWN FOR MIXTURE FOR CRACKS, JOINTS AND FLANGEWAYS IS AN ESTIMATE. THE ACTUAL AMOUNT USED WILL BE DETERMINED BY THE ENGINEER.

THE CONTRACTOR SHALL STAMP STATIONING IN THE PROPOSED BITUMINOUS SURFACE AT 300 FT. INTERVALS ON ALTERNATING SIDES OF THE PAVEMENT AND AS DIRECTED BY THE ENGINEER. THE STATION SYMBOL STAMPS USED SHALL BE FURNISHED BY THE CONTRACTOR. THEY SHALL BE 5 1/2 IN. TALL, OF A DESIGN APPROVED BY THE ENGINEER, AND SHALL REMAIN THE PROPERTY OF THE CONTRACTOR.

UNLESS OTHERWISE DIRECTED BY THE ENGINEER, HOT-MIX ASPHALT RESURFACING SHALL BE PLACED IN A SEQUENCE THAT WILL MINIMIZE THE TIME THE CENTERLINE EDGE IS EXPOSED TO TRAFFIC. WHEN AT THE END OF A DAY'S OPERATION THE EXPOSED CENTERLINE EDGE IS GREATER THAN 2,000 FT., THE CONTRACTOR SHALL BE REQUIRED TO PAVE IN THE ADJACENT LANE ON THE FOLLOWING WORK DAY. PRIOR TO WINTER SHUTDOWN, RESURFACING ON ADJACENT LANES IS TO BE BROUGHT UP TO THE SAME ELEVATION.

PRIOR TO PLACEMENT OF THE FINAL PAVEMENT MARKINGS THE RESIDENT ENGINEER SHALL CONTACT THE BUREAU OF OPERATIONS AND ARRANGE FOR INSPECTION AND APPROVAL OF THE PAVEMENT MARKING LAYOUT.

IN ADDITION TO THE REQUIREMENTS OF ARTICLE 107.16 THE CONTRACTOR SHALL PROTECT THE SURFACE OF ALL BRIDGE DECKS AND BRIDGE APPROACH PAVEMENTS IN A MANNER SATISFACTORY TO THE ENGINEER BEFORE ANY EQUIPMENT IS ALLOWED TO CROSS THE STRUCTURE. PROTECTION SHALL BE PROVIDED FOR ALL EQUIPMENT AS DEFINED IN ARTICLE 107.16 REGARDLESS IF TRACK MOUNTED OR WHEELED.

## COMMITMENTS

NONE

## MIXTURE REQUIREMENTS

LOCATION(S):	HOT-MIX ASPHALT SURFACE COURSE
MIXTURE USE(S):	HOT-MIX ASPHALT SURFACE COURSE, MIX D, N90
AC/PG:	PG64-22
ABRZ (MAX):	SEE BDE SPECIAL PROVISION
DESIGN AIR VOIDS:	4.0%, 90 GYRATION DESIGN
MIXTURE COMPOSITION: (GRADATION MIXTURE)	IL-9.5mm FINE GRADE
FRICTION AGGREGATE:	D SURFACE
QUALITY MANAGEMENT PROGRAM:	OCP

LOCATION(S):	HOT-MIX ASPHALT LEVELING BINDER
MIXTURE USE(S):	HOT-MIX ASPHALT LEVELING BINDER, N90, IL-9.5mm FINE GRADE
AC/PG:	PG64-22
ABRZ (MAX):	SEE BDE SPECIAL PROVISION
DESIGN AIR VOIDS:	4.0%, 90 GYRATION DESIGN
MIXTURE COMPOSITION: (GRADATION MIXTURE)	IL-9.5mm FINE GRADE
FRICTION AGGREGATE:	NONE
QUALITY MANAGEMENT PROGRAM:	OCP

LOCATION(S):	PAVEMENT PATCHING
MIXTURE USE(S):	HOT-MIX ASPHALT BINDER COURSE, N90, IL-19.0mm FINE GRADE
AC/PG:	PG64-22
ABRZ (MAX):	SEE BDE SPECIAL PROVISION
DESIGN AIR VOIDS:	4.0%, 90 GYRATION DESIGN
MIXTURE COMPOSITION: (GRADATION MIXTURE)	IL-9.5mm
FRICTION AGGREGATE:	NONE
QUALITY MANAGEMENT PROGRAM:	OC/OA

LOCATION(S):	INCIDENTAL HMA SURFACING
MIXTURE USE(S):	HOT-MIX ASPHALT SURFACE COURSE MIX C, N90
AC/PG:	PG64-22
ABRZ (MAX):	SEE BDE SPECIAL PROVISION
DESIGN AIR VOIDS:	4.0%, 90 GYRATION DESIGN
MIXTURE COMPOSITION: (GRADATION MIXTURE)	IL-9.5mm
FRICTION AGGREGATE:	C SURFACE
QUALITY MANAGEMENT PROGRAM:	OC/OA

FILE NAME =	USER NAME = Stover/pg	DESIGNED - _____	REVISED - _____	<b>STATE OF ILLINOIS DEPARTMENT OF TRANSPORTATION</b>	<b>GENERAL NOTES, COMMITMENTS, AND MIX DESIGN</b>	F.A.P. RTE.	SECTION	COUNTY	TOTAL SHEETS	SHEET NO.	
c:\pwwork\pwwork\stover\pg\18352831.dgn	xxxx-CA00.dgn	DRAWN - _____	REVISED - _____			869	101RS-6	FRANKLIN	13	4	
Default	PLOT SCALE = 5000:8888 * / 1in.	CHECKED - _____	REVISED - _____			SCALE: _____ SHEET _____ OF _____ SHEETS STA. _____ TO STA. _____					
	PLOT DATE = 3/21/2014	DATE - _____	REVISED - _____			ILLINOIS FED. AID PROJECT CONTRACT NO. 78388					

# SUMMARY OF QUANTITIES

CODE NUMBER	ITEM DESCRIPTION	UNIT	TOTAL QUANTITY	FRANKLIN COUNTY	
				ROADWAY	RURAL
CONSTRUCTION TYPE CODE				100% STATE	
				0005	
X4060110	BITUMINOUS MATERIALS (PRIME COAT)	POUND	11285		11285
Z0034105	MATERIAL TRANSFER DEVICE	TON	3155		3155
35101400	AGGREGATE BASE COURSE, TYPE B	TON	23		23
40600400	MIXTURE FOR CRACKS, JOINTS, AND FLANGEWAYS	TON	3		3
40600647	LEVELING BINDER (MACHINE METHOD), IL-9.5 FC, N90	TON	1,048		1,048
40600982	HOT-MIX ASPHALT SURFACE REMOVAL - BUTT JOINT	SQ YD	419		419
40600990	TEMPORARY RAMP	SQ YD	130		130
40603345	HOT-MIX ASPHALT SURFACE COURSE, MIX "D", N90	TON	2,107		2,107
40800050	INCIDENTAL HOT-MIX ASPHALT SURFACING	TON	24		24
44000155	HOT-MIX ASPHALT SURFACE REMOVAL, 1 1/2"	SQ YD	23,420		23,420
44000158	HOT-MIX ASPHALT SURFACE REMOVAL, 2 1/4"	SQ YD	1,398		1,398
44200144	PAVEMENT PATCHING, TYPE II, 12"	SQ YD	1,001		1,001
44200148	PAVEMENT PATCHING, TYPE III, 12"	SQ YD	297		297
44200150	PAVEMENT PATCHING, TYPE IV, 12"	SQ YD	185		185
48101200	AGGREGATE SHOULDERS, TYPE B	TON	429		429
67100100	MOBILIZATION	L SUM	1		1
70100460	TRAFFIC CONTROL AND PROTECTION, STANDARD 701306	L SUM	1		1
70100600	TRAFFIC CONTROL AND PROTECTION, STANDARD 701336	L SUM	1		1
70106800	CHANGEABLE MESSAGE SIGN	CAL MO	2		2
70300100	SHORT-TERM PAVEMENT MARKING	FOOT	1,736		1,736
70300220	TEMPORARY PAVEMENT MARKING - LINE 4"	FOOT	20,652		20,652
70301000	WORK ZONE PAVEMENT MARKING REMOVAL	SQ FT	6,684		6,684
* 78001110	PAVEMENT PAINT MARKING - LINE 4"	FOOT	20,652		20,652
78300200	RAISED REFLECTIVE PAVEMENT MARKER REMOVAL	EACH	109		109

\* SPECIALTY ITEM

FILE NAME *	USER NAME * Stoverda	DESIGNED -	REVISED -	<b>STATE OF ILLINOIS DEPARTMENT OF TRANSPORTATION</b>	<b>SUMMARY OF QUANTITIES</b>	F.A.P. RTE.	SECTION	COUNTY	TOTAL SHEETS	SHEET NO.	
***-CAD.dgn	***-CAD.dgn	DRAWN -	REVISED -			869	101RS-6	FRANKLIN	13	5	
PLOT SCALE - 5000:1	PLOT DATE - 3/26/2014	CHECKED -	REVISED -			CONTRACT NO. 78388					
PLOT DATE - 3/26/2014	DATE -	CHECKED -	REVISED -			ILLINOIS FED. AID PROJECT					

# TYPICAL SECTIONS

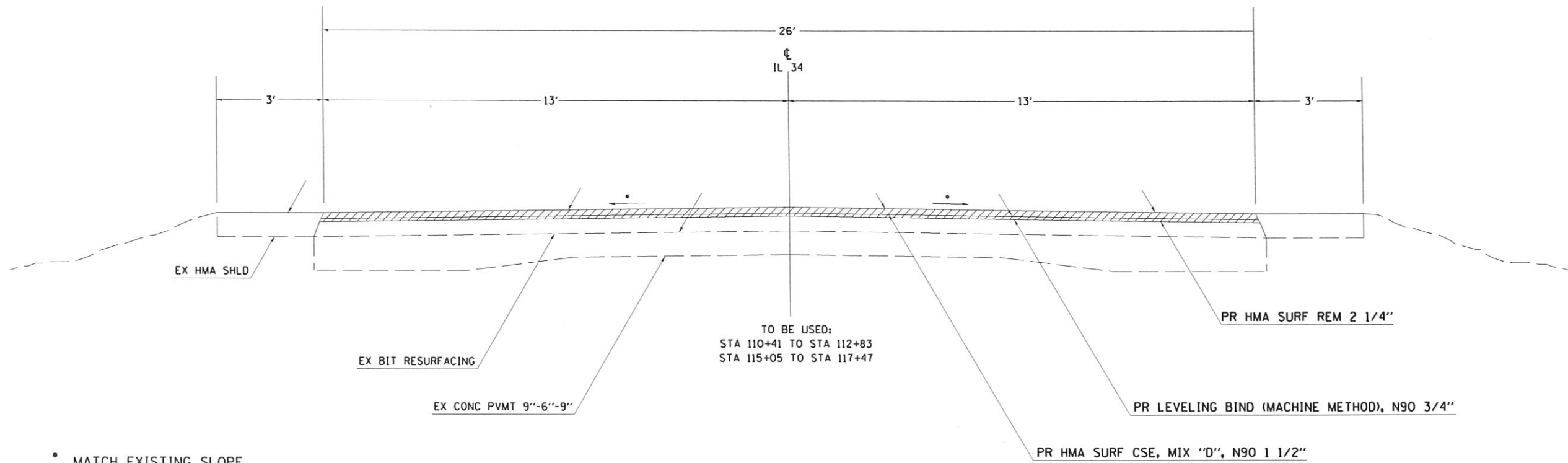
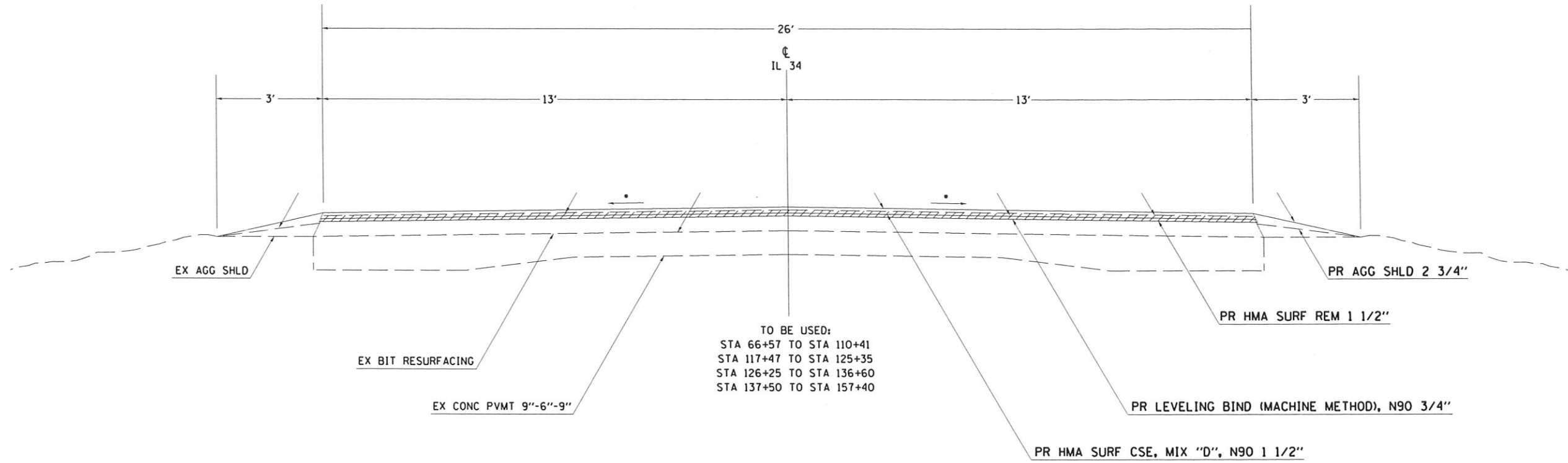

FILE NAME *	USER NAME * MeyerTA	DESIGNED -	REVISED -	<b>STATE OF ILLINOIS DEPARTMENT OF TRANSPORTATION</b>	<b>TYPICAL SECTIONS - IL 34</b>		F.A.P. RTE.	SECTION	COUNTY	TOTAL SHEETS	SHEET NO.
es:\pwork\pwork\meyer\ta\0362583\DX\...-CADD.dgn	DRAWN -	REVISED -	869				10IRS-6	FRANKLIN	13	6	
PLOT SCALE = 5000.0004' / in.	CHECKED -	REVISED -	CONTRACT NO. 78388								
PLOT DATE = 3/20/2014	DATE -	REVISED -	ILLINOIS FED. AID PROJECT								
*MODELNAME*				SCALE: _____ SHEET ____ OF ____ SHEETS STA. _____ TO STA. _____							

## RESURFACING SCHEDULE

LOCATION STATION TO STATION			LENGTH	HOT-MIX ASPHALT BINDER COURSE	HOT-MIX ASPHALT SURFACE COURSE, MIX "D", N90	BITUMINOUS MATERIALS (PRIME COAT)	AGGREGATE SHOULDERS, TYPE B	HOT-MIX ASPHALT SURFACE REMOVAL, 1 1/2"	HOT-MIX ASPHALT SURFACE REMOVAL, 2 1/4"	HOT-MIX ASPHALT SURFACE REMOVAL, BUTT JOINT	TEMPORARY RAMP
				TON	TON	POUND	TON	SQ YD	SQ YD	SQ YD	SQ YD
			FEET	TON	TON	POUND	TON	SQ YD	SQ YD	SQ YD	SQ YD
66+57	TO	110+41	4384	531	1064	5699	229	12622	0	43	14
110+41	TO	112+83	242	29	59	315	0	0	699	0	22
115+05	TO	117+47	242	29	59	315	0	0	699	0	22
117+47	TO	125+35	788	95	191	1024	41	2233	0	43	14
126+25	TO	136+60	1035	124	251	1346	54	2903	0	87	29
137+50	TO	157+40	1990	240	483	2587	104	5662	0	246	29
<b>TOTALS</b>			<b>8681</b>	<b>1048</b>	<b>2107</b>	<b>11285</b>	<b>428</b>	<b>23420</b>	<b>1398</b>	<b>419</b>	<b>130</b>

## ENTRANCE AND SIDEROAD SCHEDULE

LT/RT	PE, CE, OR SIDEROAD	SURFACE TYPE	STATION	AVERAGE WIDTH @ EOP	DIST. TO END OF APRON	AVERAGE WIDTH @ END OF APRON	INCIDENTAL HMA SURFACING	AGGREGATE WEDGE
				( FT )	( FT )	( FT )	( TON )	( TON )
LT	CE	AGG	66+72	38	4	28	0.6	0.2
LT	CE	AGG	69+49	69	4	58	1.2	0.5
RT	PE	O/C	73+07	62	4	55	0.9	
LT	STEEL CITY ROAD	O/C	73+07	80	15	37	4.4	
RT	MINE 5 ROAD	O/C	104+34	107	15	69	6.8	
LT	AKIN ROAD	HMA BIT	145+65	128	15	63	10.0	
<b>TOTALS</b>							<b>24.0</b>	<b>0.7</b>

•AN EXTRA QUANTITY OF 23 TONS OF AGGREGATE BASE COURSE, TYPE B  
HAS BEEN ADDED TO THE PLANS TO BE USED ONLY FOR OIL & CHIP  
OR AGGREGATE SIDEROADS WITH INADEQUATE SUB-BASES.

## PAVEMENT MARKING SCHEDULE

LOCATION STATION TO STATION			LENGTH	LINE 4"		REMARKS
				SOLID WHITE	SOLID YELLOW	
			FOOT	FOOT	FOOT	
66+57	TO	68+72	215	430	269	NO PASSING LEFT
68+72	TO	157+40	8868	17736	2217	PASSING
<b>SUBTOTALS</b>				<b>18,166</b>	<b>2,486</b>	
<b>TOTAL</b>				<b>20,652</b>		



PATCHING SCHEDULE - FOR INFORMATION ONLY

Lane	Width(ft)	Length(ft)	Station	Area(sqyd)	Type II	Type III	Type IV
WBL	12	9	66+08	12.0	12.0		
EBL	12	9	66+08	12.0	12.0		
WBL	12	6	67+09	8.0	8.0		
EBL	12	6	67+09	8.0	8.0		
EBL	12	8	68+11	10.7	10.7		
WBL	12	7	69+13	9.3	9.3		
EBL	12	7	70+14	9.3	9.3		
WBL	12	4	71+28	5.3	5.3		
EBL	12	4	71+28	5.3	5.3		
WBL	12	4	72+25	5.3	5.3		
EBL	12	4	72+25	5.3	5.3		
WBL	12	6	73+55	8.0	8.0		
EBL	12	6	73+55	8.0	8.0		
WBL	12	10	76+33	13.3	13.3		
WBL	12	4	78+36	5.3	5.3		
EBL	12	4	78+36	5.3	5.3		
WBL	12	4	79+36	5.3	5.3		
EBL	12	15	79+36	20.0		20.0	
WBL	12	8	80+38	10.7	10.7		
WBL	12	6	81+44	8.0	8.0		
EBL	12	6	81+44	8.0	8.0		
WBL	12	6	83+39	8.0	8.0		
EBL	12	7	83+39	9.3	9.3		
WBL	12	6	84+41	8.0	8.0		
WBL	12	10	86+45	13.3	13.3		
WBL	12	6	87+45	8.0	8.0		
EBL	12	6	87+45	8.0	8.0		
WBL	12	8	89+50	10.7	10.7		
EBL	12	11	89+50	14.7	14.7		
WBL	12	7	91+53	9.3	9.3		
EBL	12	7	91+53	9.3	9.3		
WBL	12	4	92+64	5.3	5.3		
EBL	12	6	92+64	8.0	8.0		
WBL	12	7	94+69	9.3	9.3		
EBL	12	7	94+69	9.3	9.3		
WBL	12	6	96+16	8.0	8.0		
WBL	12	6	96+54	8.0	8.0		
EBL	12	6	96+54	8.0	8.0		
WBL	12	6	99+60	8.0	8.0		
EBL	12	6	100+61	8.0	8.0		
WBL	12	17	105+74	22.7		22.7	
EBL	12	16	105+74	21.3		21.3	
WBL	12	6	106+62	8.0	8.0		
WBL	12	4	106+78	5.3	5.3		
EBL	12	4	106+78	5.3	5.3		
WBL	12	4	109+75	5.3	5.3		
EBL	12	4	109+75	5.3	5.3		
WBL	12	10	110+81	13.3	13.3		
EBL	12	4	111+09	5.3	5.3		

Lane	Width(ft)	Length(ft)	Station	Area(sqyd)	Type II	Type III	Type IV
WBL	12	4	111+16	5.3	5.3		
WBL	12	6	111+60	8.0	8.0		
EBL	12	6	111+60	8.0	8.0		
WBL	12	6	111+82	8.0	8.0		
EBL	12	6	111+82	8.0	8.0		
WBL	12	10	114+74	13.3	13.3		
EBL	12	10	114+74	13.3	13.3		
WBL	12	4	115+35	5.3	5.3		
EBL	12	4	115+35	5.3	5.3		
WBL	12	8	116+47	10.7	10.7		
EBL	12	8	116+47	10.7	10.7		
WBL	12	10	116+93	13.3	13.3		
EBL	12	10	116+93	13.3	13.3		
EBL	20	6	117+05	13.3	13.3		
WBL	12	4	117+48	5.3	5.3		
EBL	12	4	117+48	5.3	5.3		
WBL	12	27	118+02	36.0			36.0
EBL	12	27	118+02	36.0			36.0
WBL	12	4	118+48	5.3	5.3		
EBL	12	4	118+48	5.3	5.3		
EBL	12	6	118+58	8.0	8.0		
WBL	12	4	119+59	5.3	5.3		
EBL	12	4	119+59	5.3	5.3		
WBL	120	6	121+50	80.0			80.0
WBL	12	10	121+92	13.3	13.3		
EBL	12	10	121+92	13.3	13.3		
EBL	12	6	121+69	8.0	8.0		
WBL	12	17	121+69	22.7		22.7	
EBL	12	17	121+18	22.7		22.7	
WBL	12	6	121+06	8.0	8.0		
WBL	12	8	122+23	10.7	10.7		
WBL	12	5	122+63	6.7	6.7		
WBL	12	4	123+01	5.3	5.3		
WBL	12	5	123+18	6.7	6.7		
WBL	12	4	123+32	5.3	5.3		
WBL	12	4	123+76	5.3	5.3		
WBL	12	4	124+21	5.3	5.3		
WBL	12	4	124+32	5.3	5.3		
WBL	12	18	124+42	24.0		24.0	
EBL	12	18	124+42	24.0		24.0	
WBL	12	4	127+25	5.3	5.3		
EBL	12	4	127+25	5.3	5.3		
WBL	12	4	128+29	5.3	5.3		
EBL	12	4	128+29	5.3	5.3		
EBL	12	4	128+71	5.3	5.3		
WBL	12	7	129+28	9.3	9.3		
EBL	12	7	129+28	9.3	9.3		
EBL	12	8	129+50	10.7	10.7		
EBL	12	4	129+88	5.3	5.3		

Lane	Width(ft)	Length(ft)	Station	Area(sqyd)	Type II	Type III	Type IV
WBL	12	8	130+31	10.7	10.7		
EBL	12	8	130+31	10.7	10.7		
WBL	12	6	131+31	8.0	8.0		
EBL	12	17	131+31	22.7			22.7
WBL	12	10	132+30	13.3	13.3		
EBL	12	18	132+30	24.0			24.0
EBL	12	25	132+64	33.3			33.3
WBL	12	6	132+93	8.0	8.0		
WBL	12	4	133+33	5.3	5.3		
EBL	12	4	133+33	5.3	5.3		
WBL	12	18	134+21	24.0			24.0
EBL	12	18	134+21	24.0			24.0
EBL	12	4	134+64	5.3	5.3		
EBL	12	4	135+00	5.3	5.3		
EBL	12	4	135+29	5.3	5.3		
EBL	12	4	135+40	5.3	5.3		
WBL	12	6	136+00	8.0	8.0		
EBL	12	6	136+00	8.0	8.0		
WBL	12	4	137+75	5.3	5.3		
EBL	12	4	137+75	5.3	5.3		
WBL	12	4	138+55	5.3	5.3		
EBL	12	4	138+55	5.3	5.3		
WBL	12	5	138+67	6.7	6.7		
EBL	12	5	138+67	6.7	6.7		
WBL	12	4	139+23	5.3	5.3		
EBL	12	4	139+23	5.3	5.3		
WBL	12	6	139+66	8.0	8.0		
EBL	12	6	139+66	8.0	8.0		
WBL	12	4	140+61	5.3	5.3		
EBL	12	4	140+61	5.3	5.3		
WBL	12	7	140+87	9.3	9.3		
EBL	12	4	140+92	5.3	5.3		
EBL	12	4	141+78	5.3	5.3		
WBL	12	4	142+15	5.3	5.3		
EBL	12	4	142+15	5.3	5.3		
WBL	12	7	142+66	9.3	9.3		
EBL	12	7	142+66	9.3	9.3		
WBL	12	8	143+70	10.7	10.7		
WBL	12	4	144+70	5.3	5.3		
EBL	12	4	144+70	5.3	5.3		
WBL	12	6	146+79	8.0	8.0		
EBL	12	6	146+79	8.0	8.0		
WBL	12	6	148+83	8.0	8.0		
EBL	12	6	148+83	8.0	8.0		
WBL	12	4	152+88	5.3	5.3		
EBL	12	4	152+88	5.3	5.3		
WBL	12	17	153+91	22.7		22.7	
EBL	12	17	153+91	22.7		22.7	
WBL	12	4	157+00	5.3	5.3		
TOTALS							
					1001	297	185

DETAIL OF BITUMINOUS  
SIDE ROADS WITH BUTT JOINT

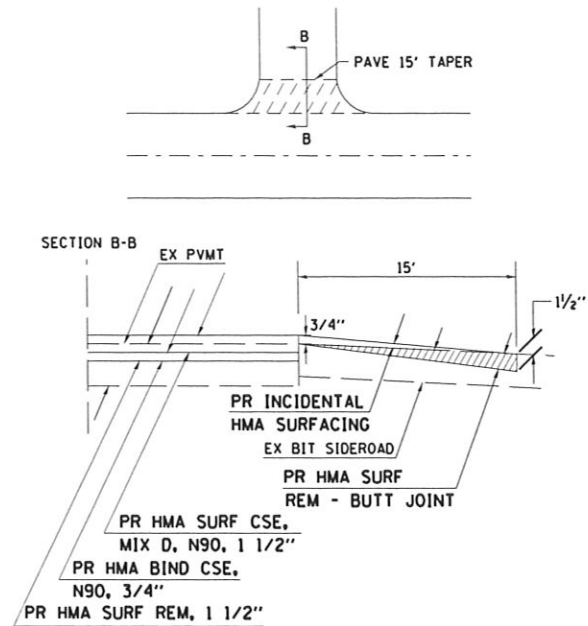

DETAIL OF BITUMINOUS, PCC, OR OIL &  
CHIP PRIVATE OR COMMERCIAL ENTRANCE

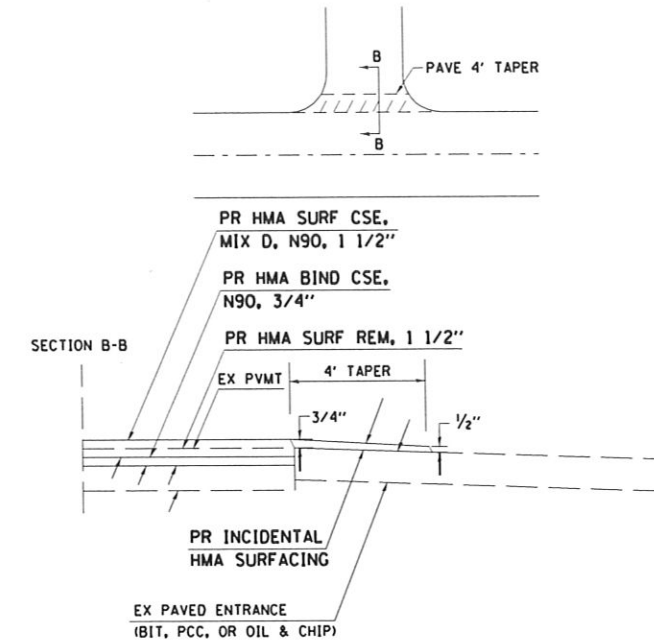

DETAIL OF AGGREGATE PRIVATE OR  
COMMERCIAL ENTRANCE

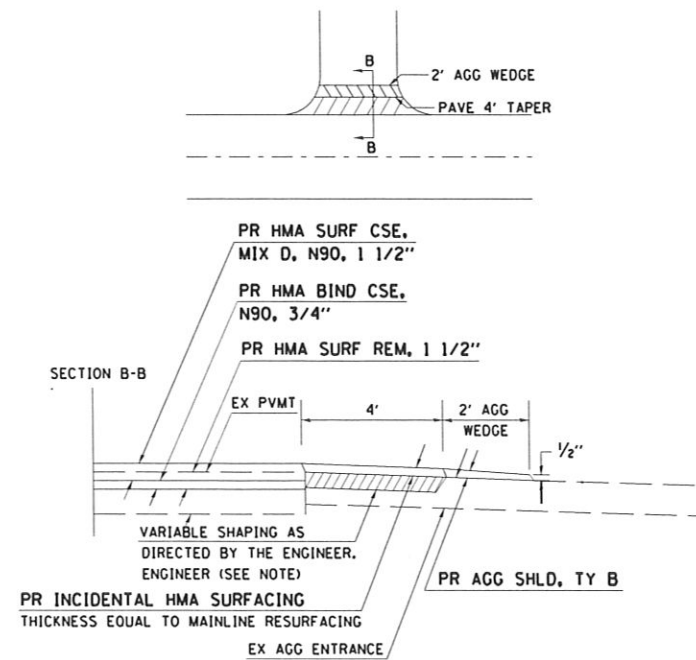

DETAIL OF OIL & CHIP  
SIDE ROAD

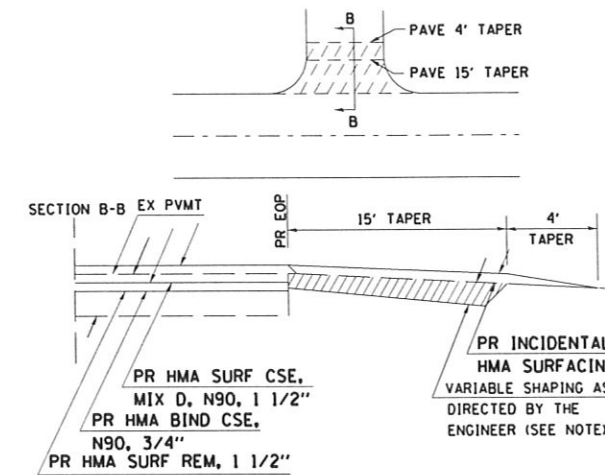

NOTES:  
VARIABLE SHAPING IS INCLUDED IN THE COST OF HOT-MIX ASPHALT.  
PREPARATION OF EXISTING SURFACE AND ANY EXCAVATION FOR ENTRANCES SHALL BE IN ACCORDANCE WITH ARTICLE 406.09 OF THE STANDARD SPECIFICATIONS.  
IF EXISTING SUB-BASE IS INADEQUATE, AS DETERMINED BY THE ENGINEER, THE SIDEROADS SHALL BE CORED OUT AND AGGREGATE SUB-BASE, TYPE B SHALL BE PLACED FOR BASE. THE COST OF CORING OUT THE SIDEROAD SHALL BE INCLUDED IN THE COST OF THE AGGREGATE BASE COURSE. IF EXISTING SUB-BASE IS DETERMINED TO BE ADEQUATE, THE AGGREGATE BASE COURSE SHALL BE DELETED AND THE PREPARATION OF THE BASE SHALL BE CONSTRUCTED ACCORDING TO ARTICLE 406.09.

FILE NAME =	USER NAME = MeyerTA	DESIGNED -	REVISED -
cc:\pwork\p\dot\meyerta\d0362583\0xxx-CADD.dgn		DRAWN -	REVISED -
	PLOT SCALE = 5000.0004' / 1in.	CHECKED -	REVISED -
#MODELNAME#	PLOT DATE = 3/20/2014	DATE -	REVISED -

STATE OF ILLINOIS  
DEPARTMENT OF TRANSPORTATION

DETAILS: SIDEROADS AND ENTRANCES

SCALE: \_\_\_\_\_ SHEET \_\_\_\_\_ OF \_\_\_\_\_ SHEETS STA. \_\_\_\_\_ TO STA. \_\_\_\_\_

F.A.P. RTE. 869	SECTION 10IRS-6	COUNTY FRANKLIN	TOTAL SHEETS 13	SHEET NO. 10
CONTRACT NO. 78388				
ILLINOIS FED. AID PROJECT				

# BUTT JOINT DETAIL

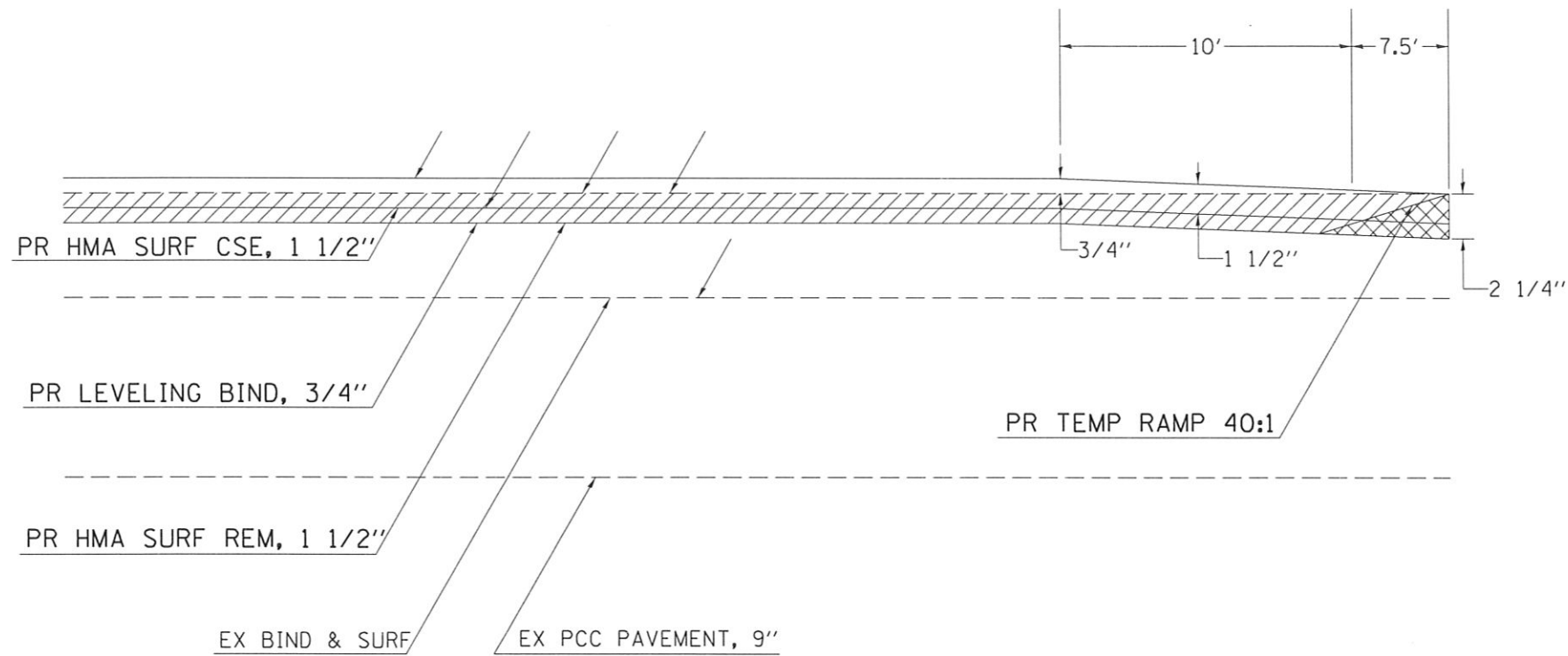

TO BE USED:  
 STA 66+57 BEGINNING OF PROJECT  
 SN 028-0044 STA 125+35 WEST ABUT; STA 126+25 EAST ABUT  
 SN 028-0045 STA 136+60 WEST ABUT; STA 137+50 EAST ABUT  
 STA 157+40 END OF PROJECT

# TEMPORARY RAMP DETAIL

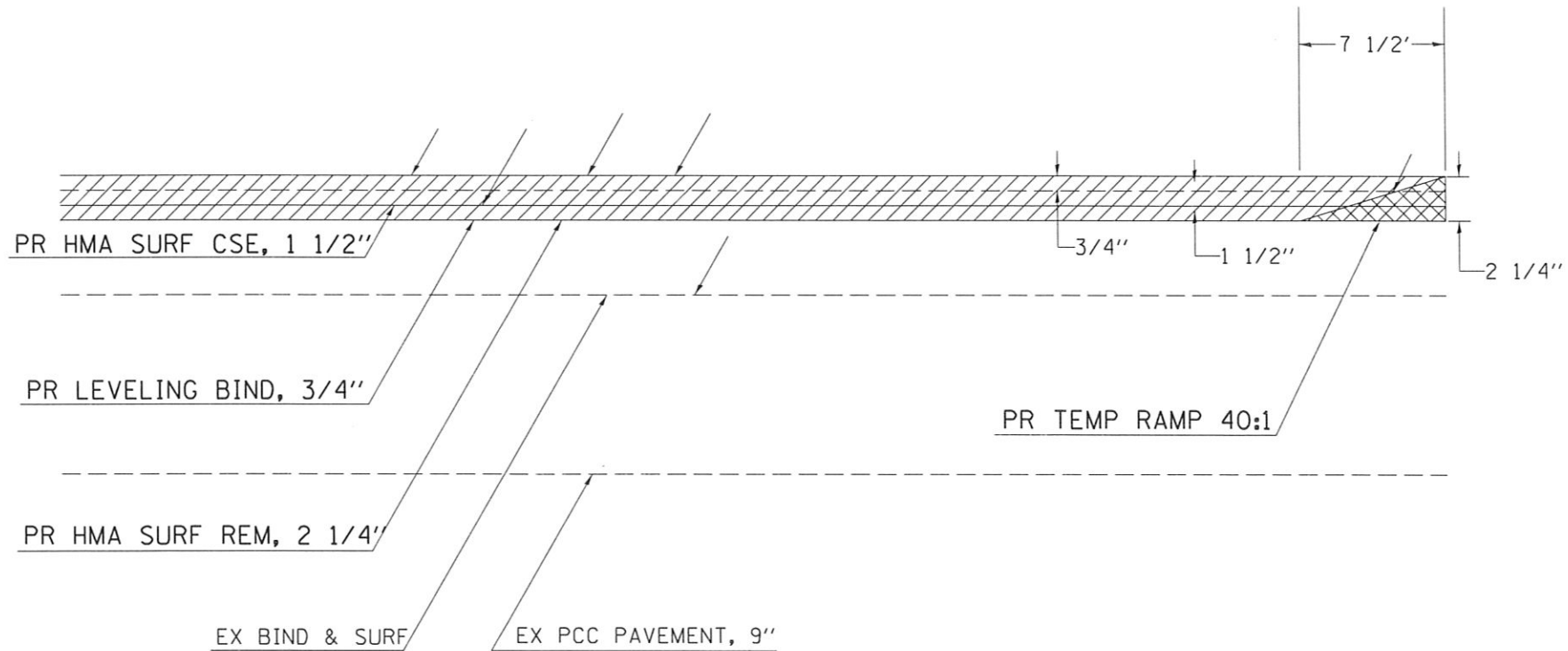

TO BE USED:  
 SN 028-0043 STA 112+83 WEST ABUT; STA 115+05 EAST ABUT

FILE NAME =	USER NAME = Stoverpg	DESIGNED - _____	REVISED - _____	<b>STATE OF ILLINOIS DEPARTMENT OF TRANSPORTATION</b>	<b>DETAILS: TEMPORARY RAMP AND BUTT JOINT</b>	F.A.P. RTE. 869	SECTION 101RS-6	COUNTY FRANKLIN	TOTAL SHEETS 13	SHEET NO. 11	
Default	Plot Scale = 5000.0000' / in.	CHECKED - _____	REVISED - _____			SCALE: _____ SHEET _____ OF _____ SHEETS	STA. _____ TO STA. _____	ILLINOIS FED. AID PROJECT			
	PLOT DATE = 3/21/2014	DATE - _____	REVISED - _____			CONTRACT NO. 78388					

# MILLING TAPER DETAIL SN 028-0043

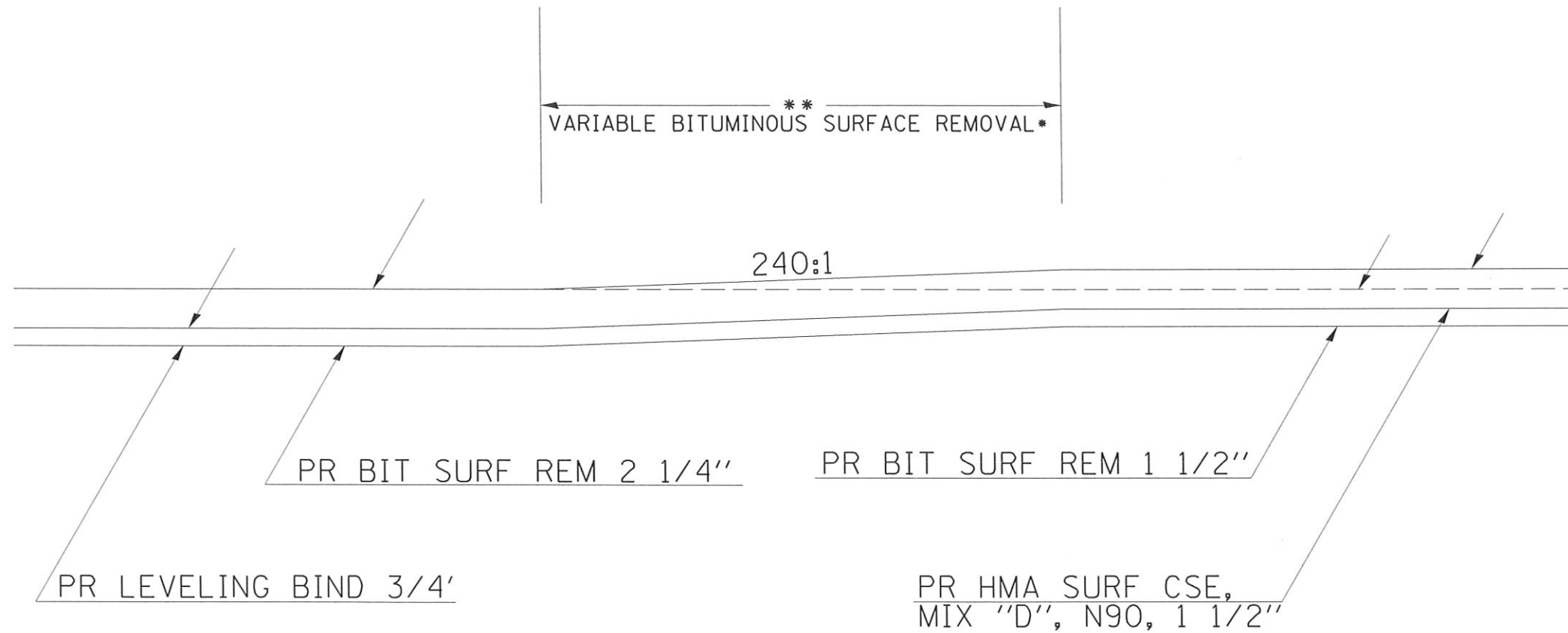

**NOTE:**

\* VARIABLE BITUMINOUS SURFACE REMOVAL WILL BE PAID FOR AS BITUMINOUS SURFACE REMOVAL 1 1/2"

\*\* TAPER LENGTH AS DIRECTED BY THE ENGINEER TO MAINTAIN 240:1 TAPER RATIO

**TO BE USED:**

SN 028-0043 STA 110+26 TO STA 110+41 WEST ABUT  
SN 028-0043 STA 117+47 TO STA 117+62 EAST ABUT

FILE NAME =	USER NAME = MeyerTA	DESIGNED - _____	REVISED - _____	<b>STATE OF ILLINOIS DEPARTMENT OF TRANSPORTATION</b>	<b>DETAILS: MILLING TAPER</b>	F.A.P. RTE.	SECTION	COUNTY	TOTAL SHEETS	SHEET NO.
ca:\p\work\p\pidot\meyer\ta\d0362583\DX...	...-CADD.dgn	DRAWN - _____	REVISED - _____			869	10IRS-6	FRANKLIN	13	12
*MODELNAME*	PLOT SCALE = 5000.0000 ' / in.	CHECKED - _____	REVISED - _____		SCALE: _____ SHEET ____ OF ____ SHEETS STA. _____ TO STA. _____	CONTRACT NO. 78388				
	PLOT DATE = 3/20/2014	DATE - _____	REVISED - _____			ILLINOIS FED. AID PROJECT				

## TEMPORARY HOT-MIX ASPHALT TRANSITIONS

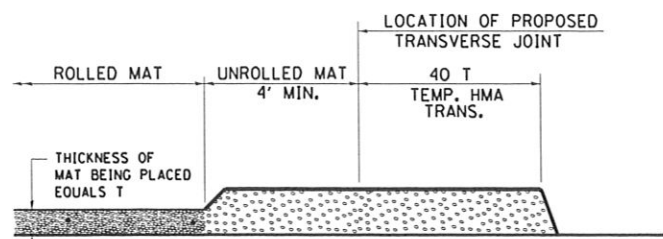

### STEP I

1. PLACE HOT-MIX ASPHALT MAT, LENGTH 40 TIMES THE THICKNESS OF THE MAT BEING PLACED PAST THE PROPOSED TRANSVERSE JOINT LOCATION USING NORMAL OPERATING PROCEDURES.
2. EXTREME CARE SHOULD BE TAKEN TO MAINTAIN ENOUGH MATERIAL IN FRONT OF THE SCREED TO MAINTAIN REQUIRED PAVING DEPTH.

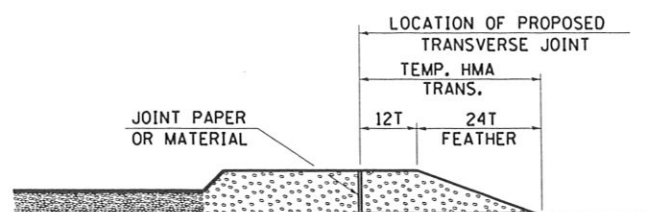

### STEP III

1. JOINT PAPER OR OTHER PRESELECTED JOINT MATERIAL IS THEN PLACED IN THE CLEARED AREA AND THE EXCESS ASPHALT USED TO HAND FORM A TRANSITION TO THE DIMENSIONS SHOWN ABOVE.
2. NOTE THAT IN CONSTRUCTING THE TRANSITION, THE MAT DEPTH IS CONTINUED AS PART OF THE TRANSITION BEFORE FORMING THE FEATHER.

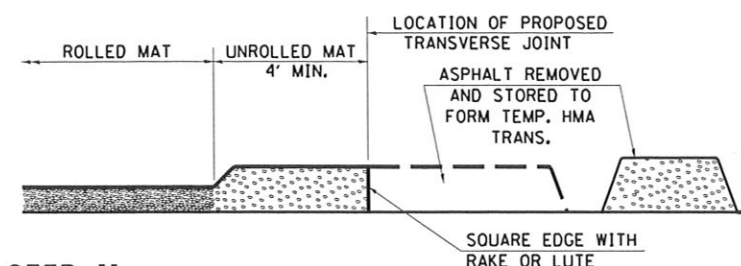

### STEP II

1. MOVE THE PAVER OUT OF THE WAY AND REMOVE THE ASPHALT FROM THE AREA OF THE PROPOSED TEMPORARY HOT-MIX ASPHALT TRANSITION.
2. SQUARE UP THE END OF THE MAT WITH A RAKE OR LUTE.
3. NOTE THAT THE MAT WITHIN 4' OF THE END OF JOINT IS NOT TO BE ROLLED AT THIS TIME.

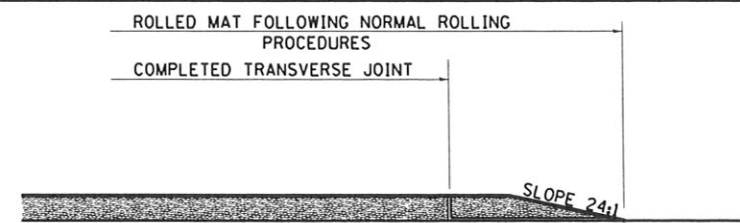

### STEP IV

1. COMPLETE TEMPORARY TRANSITION BY ROLLING.
2. TO RESUME PAVING, AT THE JOINT, REMOVE TEMPORARY TRANSITION AND DISPOSE OF THE MATERIAL ACCORDING TO ART. 202.03 OF THE STD. SPECS. (COST INCLUDED IN THE CONTRACT).
3. CONSTRUCTING THE TEMPORARY TRANSITIONS WILL NOT BE PAID FOR SEPARATELY BUT WILL BE INCLUDED IN THE HOT-MIX ASPHALT MATERIAL BEING PLACED.

## UNEVEN LANES SIGN

WB-11 (48" x 48")

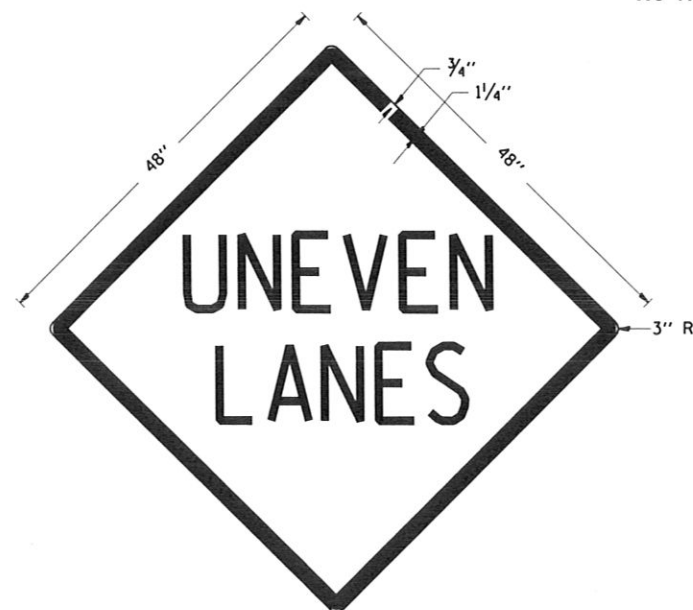

**COLORS:**  
LEGEND AND BORDER - BLACK NON-REFLECTORIZED  
BACKGROUND - ORANGE REFLECTORIZED

**NOTE:** PRIOR TO ALLOWING TRAFFIC ON ANY PORTION OF THE ROADWAY THAT HAS BEEN COLDMILLED OR BEFORE RESURFACING OPERATIONS BEGIN, THE CONTRACTOR SHALL HAVE ERECTED "UNEVEN PAVEMENT" SIGNS THAT CONFORM TO THE ABOVE DETAILS. A MINIMUM OF ONE SIGN AT EACH END OF THE IMPROVEMENT WILL BE REQUIRED. THE CONTRACTOR SHALL MAINTAIN THE "UNEVEN PAVEMENT" SIGNS UNTIL THE RESURFACING OPERATIONS ARE COMPLETED.

IF AT ANY TIME THE SIGNS ARE IN PLACE BUT NOT APPLICABLE, THEY SHALL BE TURNED FROM THE VIEW OF MOTORISTS OR COVERED AS DIRECTED BY THE ENGINEER.

THE COST OF FURNISHING, ERECTING, MAINTAINING, AND REMOVING THE REQUIRED SIGNS SHALL BE INCLUDED IN THE CONTRACT.

## ILLINOIS STANDARD

WB-1106

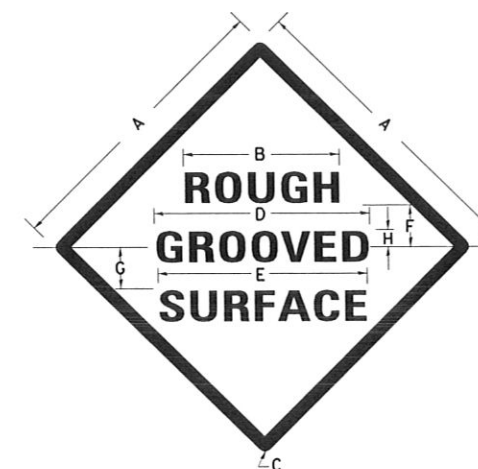

### COLORS:

LEGEND AND BORDER - BLACK NON-REFLECTORIZED  
BACKGROUND - ORANGE REFLECTORIZED

SIGN SIZE	DIMENSIONS							
	A	B	C	D	E	F	G	H
48X48	48.0	24.1	3.0	34.0	33.0	6.0	13.0	3.5

SIGN SIZE	SERIES LINES			MAR-GIN	BOR-DER	BLANK STD.
	1	2	3			
48X48	7C	7C	7C	0.8	1.2	B4-48D

ALL DIMENSIONS IN INCHES

### NOTES:

PRIOR TO ALLOWING TRAFFIC ON ANY PORTION OF THE ROADWAY THAT HAS BEEN COLDMILLED, THE CONTRACTOR SHALL HAVE ERECTED "ROUGH GROOVED SURFACE" SIGNS THAT CONFORM TO THE ABOVE DETAILS. A MINIMUM OF ONE SIGN AT EACH END OF THE IMPROVEMENT WILL BE REQUIRED. THE CONTRACTOR SHALL MAINTAIN THE "ROUGH GROOVED SURFACE" SIGNS UNTIL THE COLDMILLED SURFACE IS COVERED WITH LEVELING BINDER OR SURFACE COURSE.

IF AT ANY TIME THE SIGNS ARE IN PLACE BUT NOT APPLICABLE, THEY SHALL BE TURNED FROM THE VIEW OF MOTORISTS OR COVERED AS DIRECTED BY THE ENGINEER.

THE COST OF FURNISHING, ERECTING, MAINTAINING, AND REMOVING THE REQUIRED SIGNS SHALL BE INCLUDED IN THE CONTRACT.