

P:\09-0016-02 Rieder Road Phase II\18 CAD\CADD Sheets\09-0016-sht-landscape.dgn  
 FILE NAME = 09-0016-sht-landscape.dgn  
 USER NAME = IDOT  
 MODEL NAME = Default  
 PLOT SCALE = 100,0000' / in.  
 PLOT DATE = 4/29/2014

DESIGNED -	REVISED -
DRAWN -	REVISED -
CHECKED -	REVISED -
DATE - April 29, 2014	REVISED -

**STATE OF ILLINOIS**  
**DEPARTMENT OF TRANSPORTATION**

**LANDSCAPE PLAN**  
**FAI-64 AND PROPOSED RIEDER ROAD**

SCALE: SHEET NO. 1 OF 2 SHEETS STA. 51+75 TO STA. 64+50

F.A.I. RTE.	SECTION	COUNTY	TOTAL SHEETS	SHEET NO.
64	09-00365-01-PV	ST. CLAIR	535	201
TR RTE. 222 (RIEDER ROAD)			CONTRACT NO. 97549	
ILLINOIS				

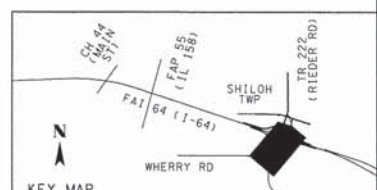
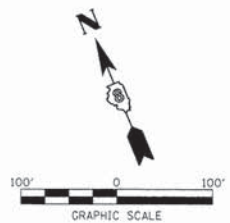

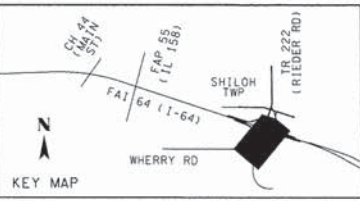

LEGEND

ID NO.	DESCRIPTION	SPACING
1	SHRUB, SAMBUCUS CANADENSIS (AMERICAN ELDER), 3' HEIGHT, BALLED AND BURLAPPED	10'
2	TREE, CERCIIS CANADENSIS (EASTERN REDBUD), 2" CALIPER, TREE FORM, BALLED AND BURLAPPED	15'-20'
3	TREE, AMELANCHIER X GRANDIFLORA COLE'S SELECT (COLE'S SELECT SERVICEBERRY), 6' HEIGHT, SHRUB FORM, BALLED AND BURLAPPED	15'-20'
4	TREE, ULMUS MORTON GLOSSY (TRIUMPH ELM), 2" CALIPER, BALLED AND BURLAPPED	30'
5	TREE, QUERCUS RUBRA (RED OAK), 2" CALIPER, BALLED AND BURLAPPED	30'
6	TREE, QUERCUS IMBRICARIA (SHINGLE OAK), 6' HEIGHT, CLUMP FORM, BALLED AND BURLAPPED	30'
7	TREE, NYSSA SYLVATICA (BLACK TUPELO), 8' HEIGHT, CLUMP FORM, BALLED AND BURLAPPED	30'
8	TREE, GYMNOCLADUS DIOICUS PRAIRIE TITAN, (PRAIRIE TITAN KENTUCKY COFFEETREE), 2-1/2" CALIPER, BALLED AND BURLAPPED	20'
9	TREE, CELTIS OCCIDENTALIS PRAIRIE PRIDE (PRAIRIE PRIDE HACKBERRY), 2" CALIPER, BALLED AND BURLAPPED	30'
10	TREE, ACER RUBRUM RED SUNSET (RED SUNSET RED MAPLE), 2" CALIPER, BALLED AND BURLAPPED	20'
11	EVERGREEN, PINUS STROBUS (EASTERN WHITE PINE), 6' HEIGHT, BALLED AND BURLAPPED	30'
12	TREE, TAXODIUM DISTICHUM (COMMON BALD CYPRESS), 2" CALIPER, BALLED AND BURLAPPED	30'

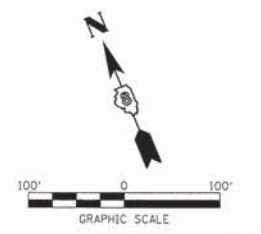
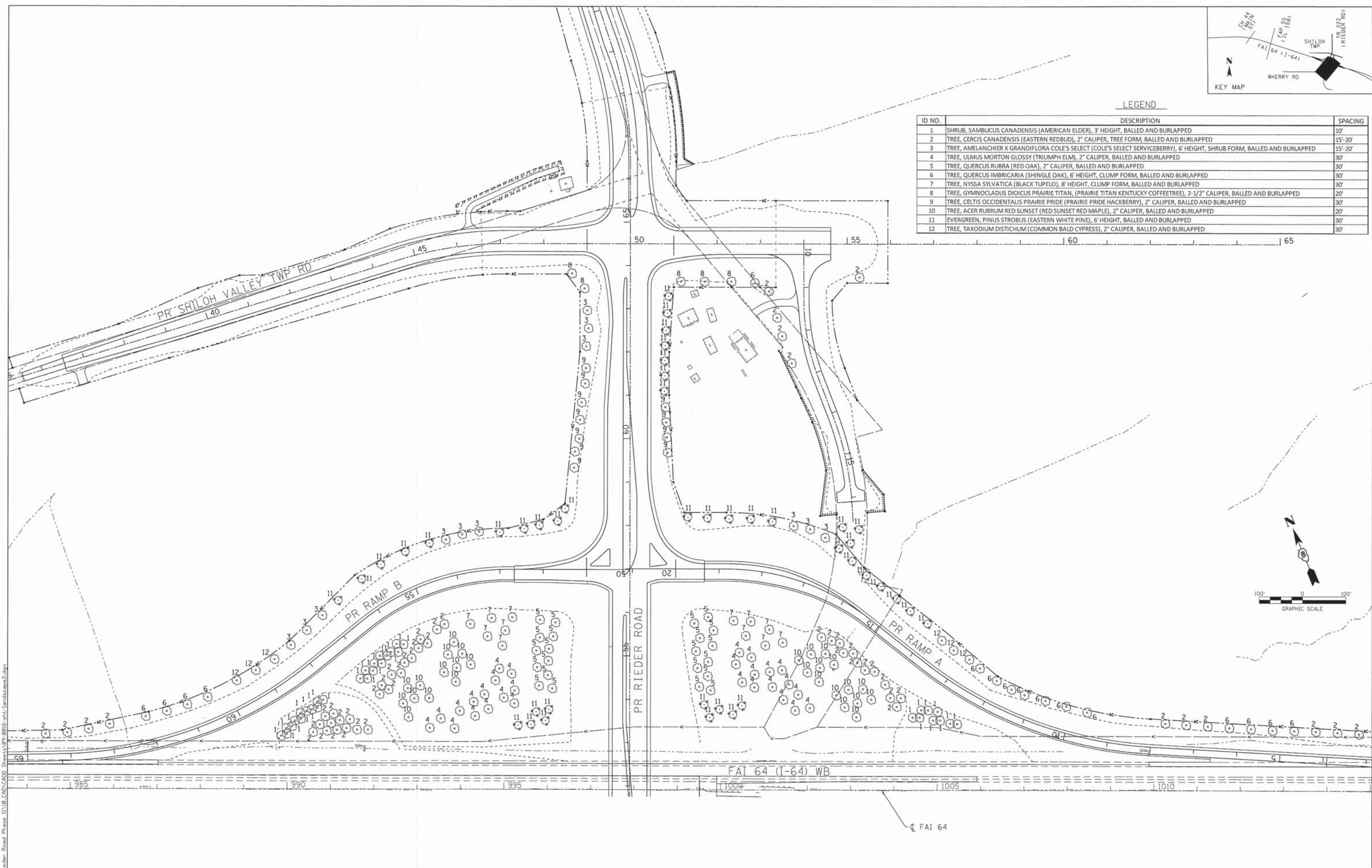

P:\09-2016\02 Rieder Road Phase 1\1110 CAD\CAD Sheets\09-2016-shr-landscape2.dgn  
 FILE NAME = 09-2016-shr-landscape2.dgn  
 USER NAME = IDOT  
 MODEL NAME = Default  
 PLOT SCALE = 100.0000' / 1" =  
 PLOT DATE = 4/26/2014  
 DESIGNED -  
 DRAWN -  
 CHECKED -  
 DATE - April 29, 2014  
 REVISED -  
 REVISED -  
 REVISED -  
 REVISED -

STATE OF ILLINOIS  
DEPARTMENT OF TRANSPORTATION

LANDSCAPE PLAN  
FAI-64 AND PROPOSED RIEDER ROAD

SCALE: 1"=100' SHEET NO. 2 OF 2 SHEETS STA. 51+75 TO STA. 64+50

F.A.I. RTE.	SECTION	COUNTY	TOTAL SHEETS	SHEET NO.
64	09-00365-01-PV	ST. CLAIR	535	202
TR RTE. 222 (RIEDER ROAD)		CONTRACT NO. 97549		
ILLINOIS				

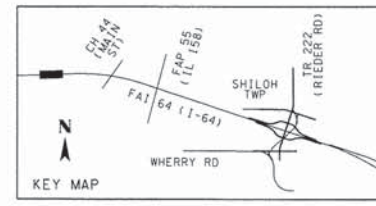

\*  
**LODGING - EXIT 16**

\*  
**Illinois 159 5**  
**East St. Louis 16**  
**St. Louis 19**

BEGINNING OF PROJECT  
 ☐ STA 846+02.28 FAI 64 (I-64)

BEGIN MEDIAN IMPROVEMENTS  
 ☐ STA 848+72.28 FAI 64 (I-64)

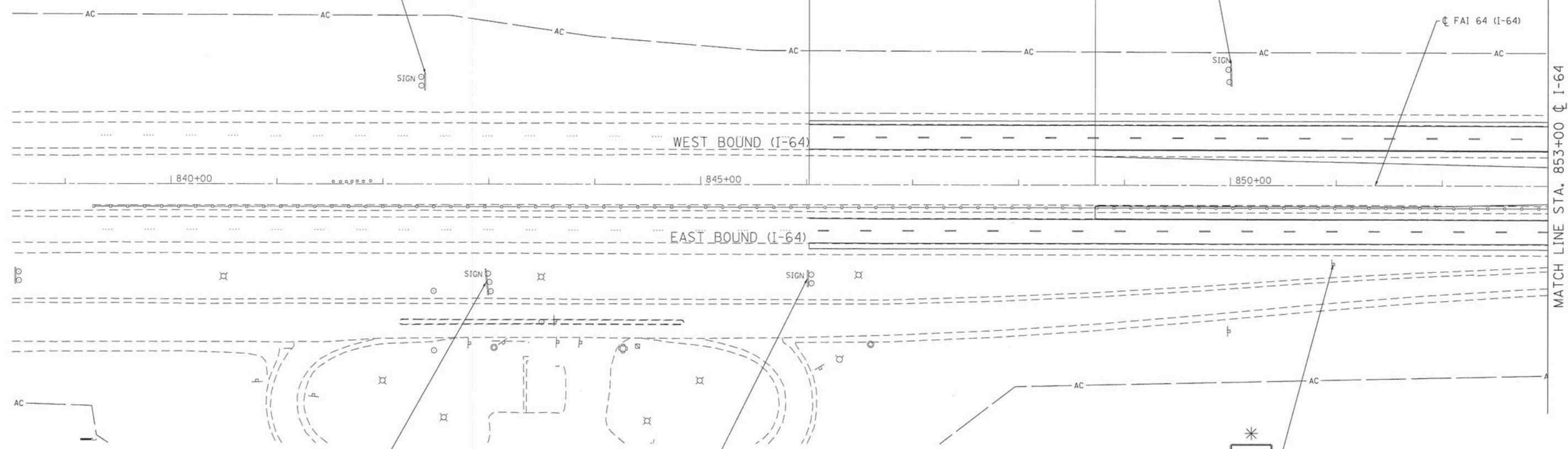

\*  
**EXITS 19 A-B**  
 50 ILLINOIS 158  
**Scott A.F. Base**  
**Carlyle**  
**1 MILE**

\*  
**FOOD - EXITS**

\*  
**NO PARKING**

\* **M** MOUNTED ON SIGN POST

⊗ EXISTING SIGN TO BE REMOVED  
 \* EXISTING SIGN TO REMAIN

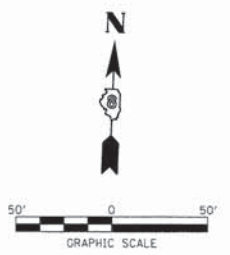

NOTE: SIGNING FOR WEIGH STATION NOT SHOWN ON THIS PLAN.

FILE NAME =  
 09-0016-sht-1-64 Sign01.dgn

USER NAME = IDOT  
 MODEL NAME = Default  
 PLOT SCALE = 600,0000 ' / ft.  
 PLOT DATE = 4/26/2014

DESIGNED - SMS  
 DRAWN - SMS  
 CHECKED - LDC  
 DATE - April 29, 2014

REVISED -  
 REVISED -  
 REVISED -  
 REVISED -

**STATE OF ILLINOIS**  
**DEPARTMENT OF TRANSPORTATION**

**SIGNING PLAN**  
**PROPOSED WIDENING FAI 64 (I-64)**  
 SCALE: 1" = 50' SHEET NO. 1 OF 37 SHEETS STA. 838+00 TO STA. 853+00

F.A.I. RTE.	SECTION	COUNTY	TOTAL SHEETS	SHEET NO.
64	09-00365-01-PV	ST. CLAIR	535	203
TR RTE. 222 (RIEDER ROAD)			CONTRACT NO. 97549	
[ILLINOIS]				

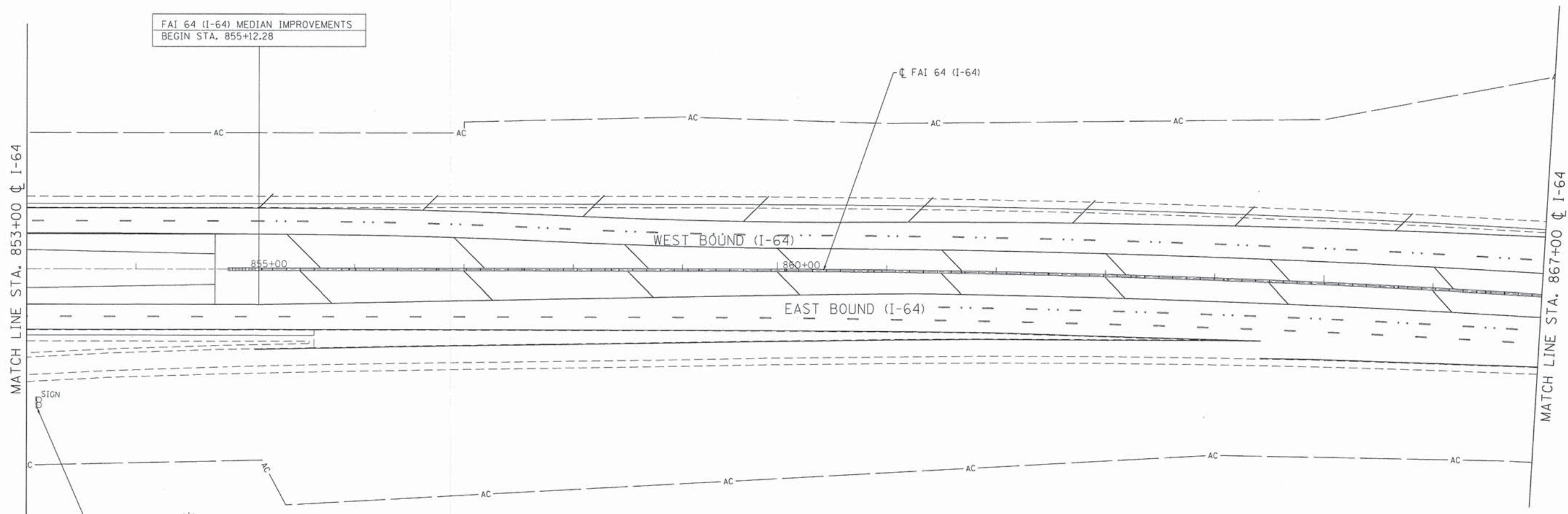
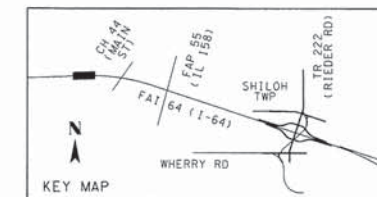

FAI 64 (I-64) MEDIAN IMPROVEMENTS  
BEGIN STA. 855+12.28

**NOTICE**  
MOVE OVER - SLOW DOWN  
FOR STOPPED  
EMERGENCY OR  
MAINTENANCE VEHICLES  
IT'S THE LAW

☒ EXISTING SIGN TO BE REMOVED  
\* EXISTING SIGN TO REMAIN

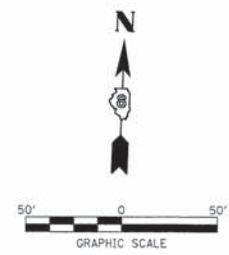

P:\09-0016-02 Rieder Road Phase II\18 CAD\CADD Sheets\09-0016-sht-1-64\_Sign02.dgn

FILE NAME = 09-0016-sht-1-64_Sign02.dgn	USER NAME = IDOT	DESIGNED - SMS	REVISED -
MODEL NAME = Default	DRAWN - SMS	CHECKED - LDC	REVISED -
PLOT SCALE = 600.0000' / ft.	DATE - Apr 29, 2014		REVISED -

**STATE OF ILLINOIS  
DEPARTMENT OF TRANSPORTATION**

**SIGNING PLAN  
PROPOSED WIDENING FAI 64 (I-64)**

SCALE: 1" = 50'    SHEET NO. 2 OF 37 SHEETS    STA. 853+00    TO STA. 867+00

F.A.I. RTE.	SECTION	COUNTY	TOTAL SHEETS	SHEET NO.
64	09-00365-01-PV	ST. CLAIR	535	204
TR RTE. 222 (RIEDER ROAD)			CONTRACT NO. 97549	
ILLINOIS				

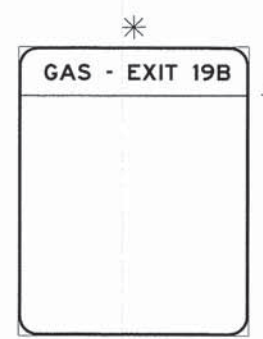
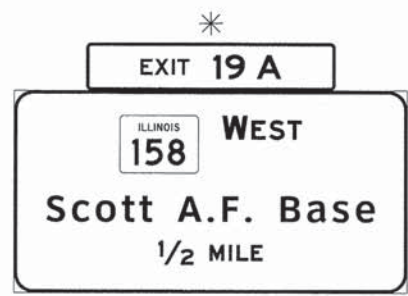
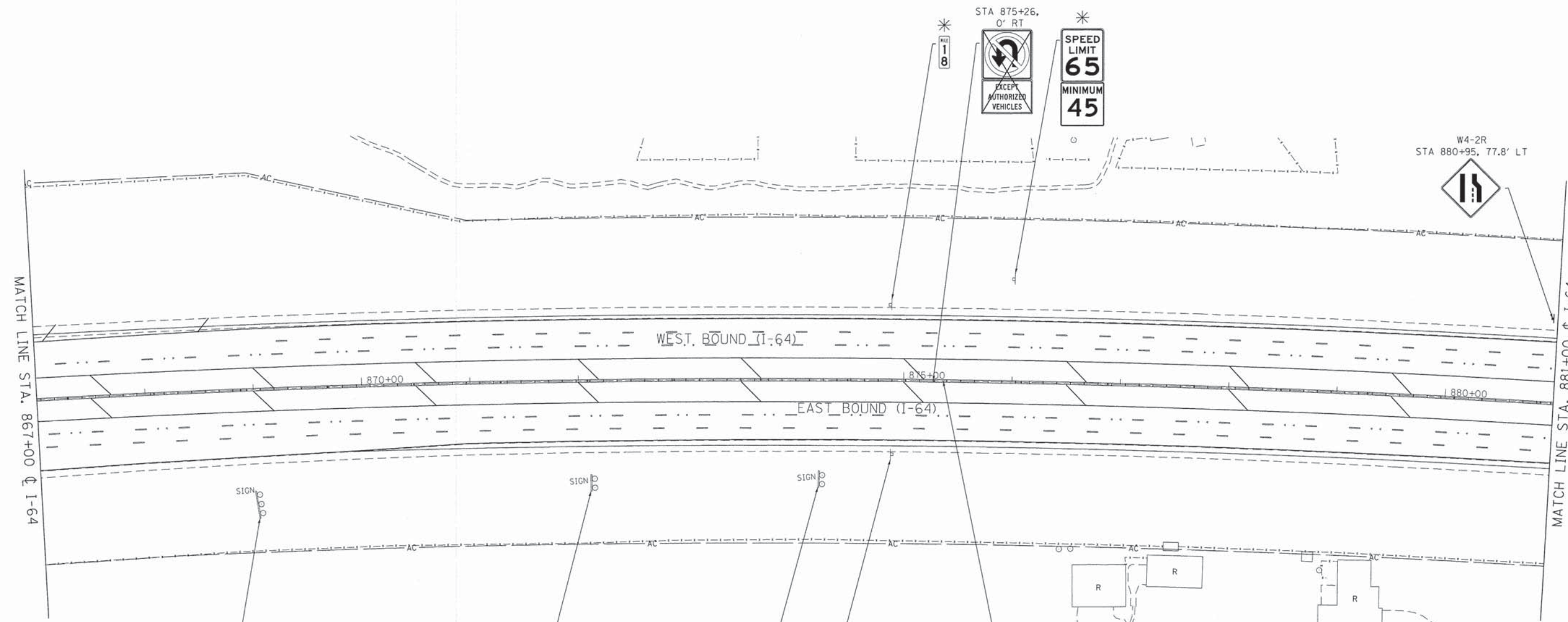
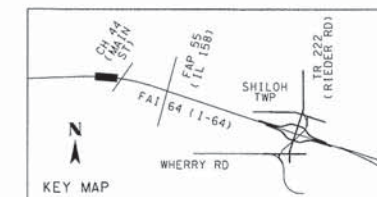

 EXISTING SIGN TO BE REMOVED  
 EXISTING SIGN TO REMAIN

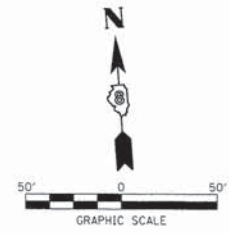

P:\09-0016-02 Rieder Road Phase 1\118 CAD\CADD Sheets\09-0016-sht-1-64\_Sign03.dgn

FILE NAME = 09-0016-sht-1-64_Sign03.dgn	USER NAME = IDOT	DESIGNED - SMS	REVISED -
MODEL NAME = Default	DRAWN - SMS	REVISIONS -	
PLOT SCALE = 600.0000' / ft.	CHECKED - LDC	REVISIONS -	
PLOT DATE = 4/26/2014	DATE - April 29, 2014	REVISIONS -	

**STATE OF ILLINOIS**  
**DEPARTMENT OF TRANSPORTATION**

**SIGNING PLAN**  
**PROPOSED WIDENING FAI 64 (I-64)**

SCALE: 1" = 50'    SHEET NO. 3 OF 37 SHEETS    STA. 867+00 TO STA. 881+00

F.A.I. RTE.	SECTION	COUNTY	TOTAL SHEETS	SHEET NO.
64	09-00365-01-PV	ST. CLAIR	535	205
TR RTE. 222 (RIEDER ROAD)		CONTRACT NO. 97549		
ILLINOIS				

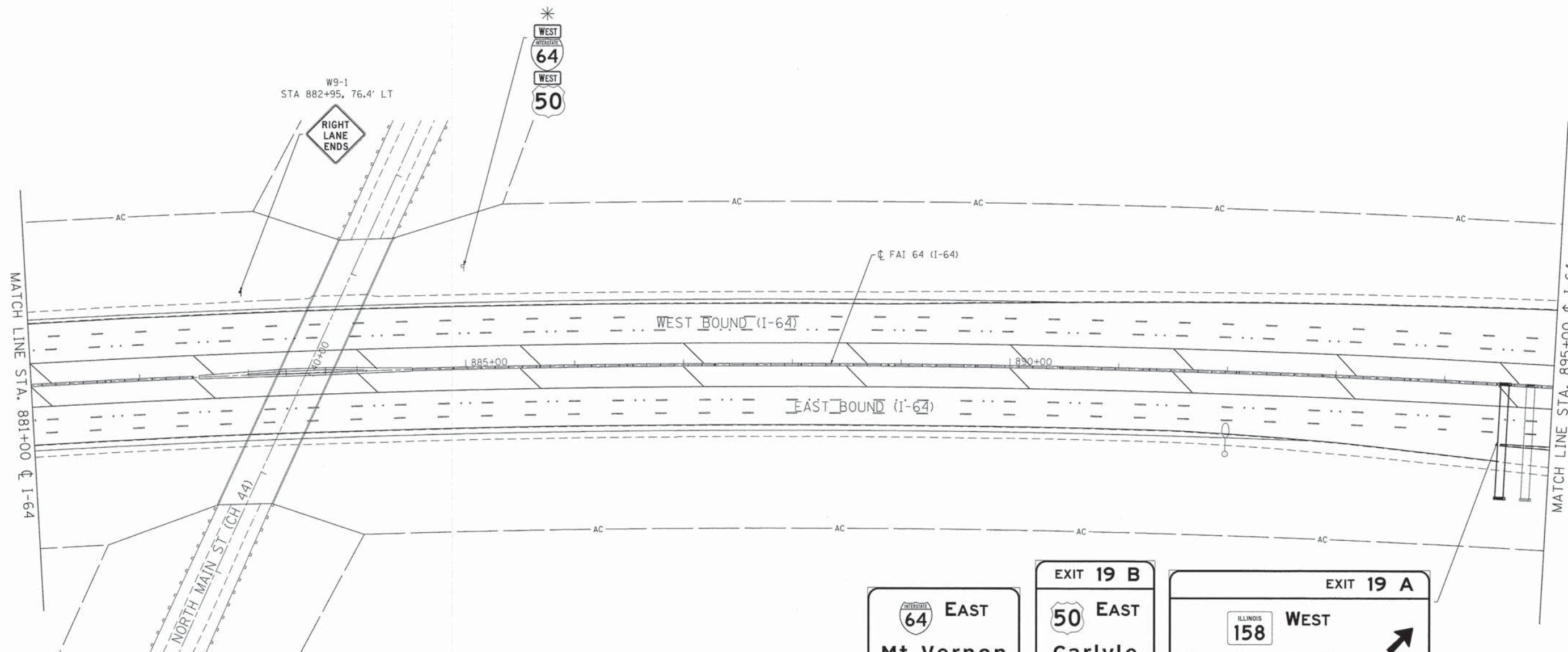
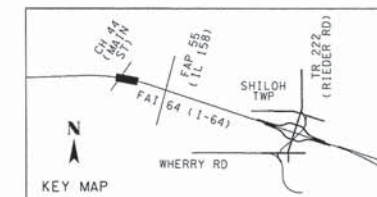

W9-1  
STA 882+95, 76.4' LT



EXIT 19 B

EXIT 19 A

STR NO 8S0821064R018.4  
STA 894+56



RELOCATED SIGN ASSEMBLY  
MOUNT ON SIGN TRUSS POST

- EXISTING SIGN TO BE REMOVED
- EXISTING SIGN TO REMAIN

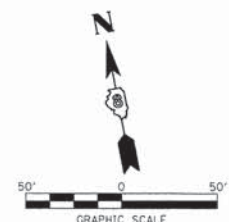

P:\09-0016-02\_Roadway\_Road\_Phase\_1\19\_CADD\CADD\_Sheets\09-0016-02-1-64\_Sign04.dgn

FILE NAME = 09-0016-02-1-64_Sign04.dgn	USER NAME = IDOT	DESIGNED - SMS	REVISED - -
MODEL NAME = Default	DRAWN - SMS	CHECKED - LDC	REVISED - -
PLOT SCALE = 600,0000' / ft.	DATE - April 29, 2014		REVISED - -

**STATE OF ILLINOIS  
DEPARTMENT OF TRANSPORTATION**

**SIGNING PLAN  
PROPOSED WIDENING FAI 64 (I-64)**

F.A.I. RTE.	SECTION	COUNTY	TOTAL SHEETS	SHEET NO.
64	09-00365-01-PV	ST. CLAIR	535	206
TR RTE. 222 (RIEDER ROAD)		CONTRACT NO. 97549		

SCALE: 1" = 50'    SHEET NO. 4 OF 37 SHEETS    STA. 881+00 TO STA. 895+00

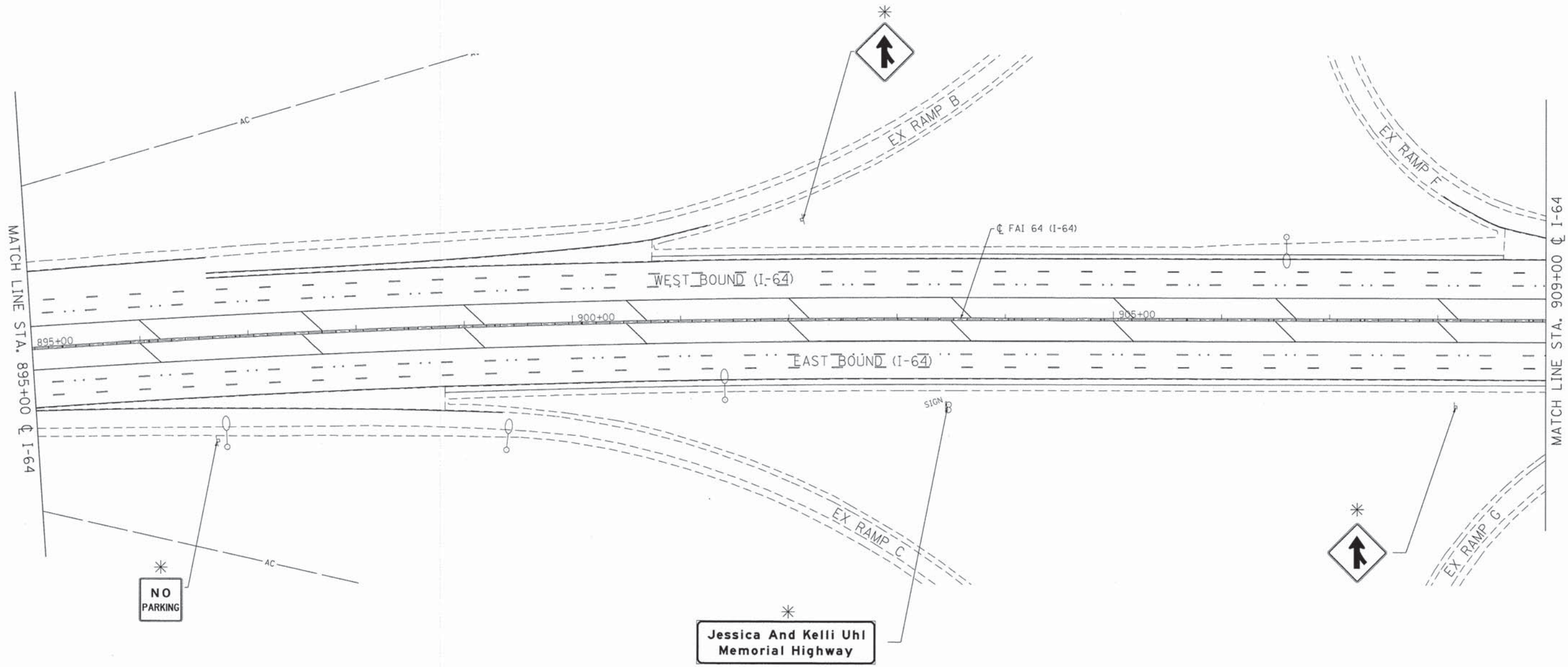
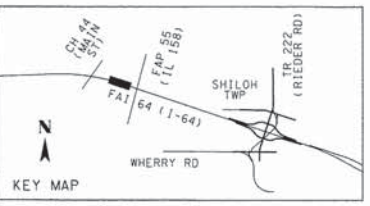

EXISTING SIGN TO BE REMOVED  
 EXISTING SIGN TO REMAIN

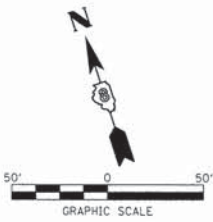

P:\09-0016\02 Rieder Road Phase 1\1\B\CAD\CADD Sheets\09-0016-sht-1-64\_Sign05.dgn

FILE NAME = 09-0016-sht-1-64_Sign05.dgn	USER NAME = IDOT	DESIGNED - SMS	REVISED -
MODEL NAME = Default	DRAWN - SMS	CHECKED - LDC	REVISED -
PLOT SCALE = 600.0000' / ft.	DATE - April 29, 2014		
PLOT DATE = 4/26/2014			

**STATE OF ILLINOIS**  
**DEPARTMENT OF TRANSPORTATION**

**SIGNING PLAN**  
**PROPOSED WIDENING FAI 64 (I-64)**

SCALE: 1" = 50'    SHEET NO. 5 OF 37 SHEETS    STA. 895+00 TO STA. 909+00

F.A.I. RTE.	SECTION	COUNTY	TOTAL SHEETS	SHEET NO.
64	09-00365-01-PV	ST. CLAIR	535	207
TR RTE. 222 (RIEDER ROAD)		CONTRACT NO. 97549		
ILLINOIS				

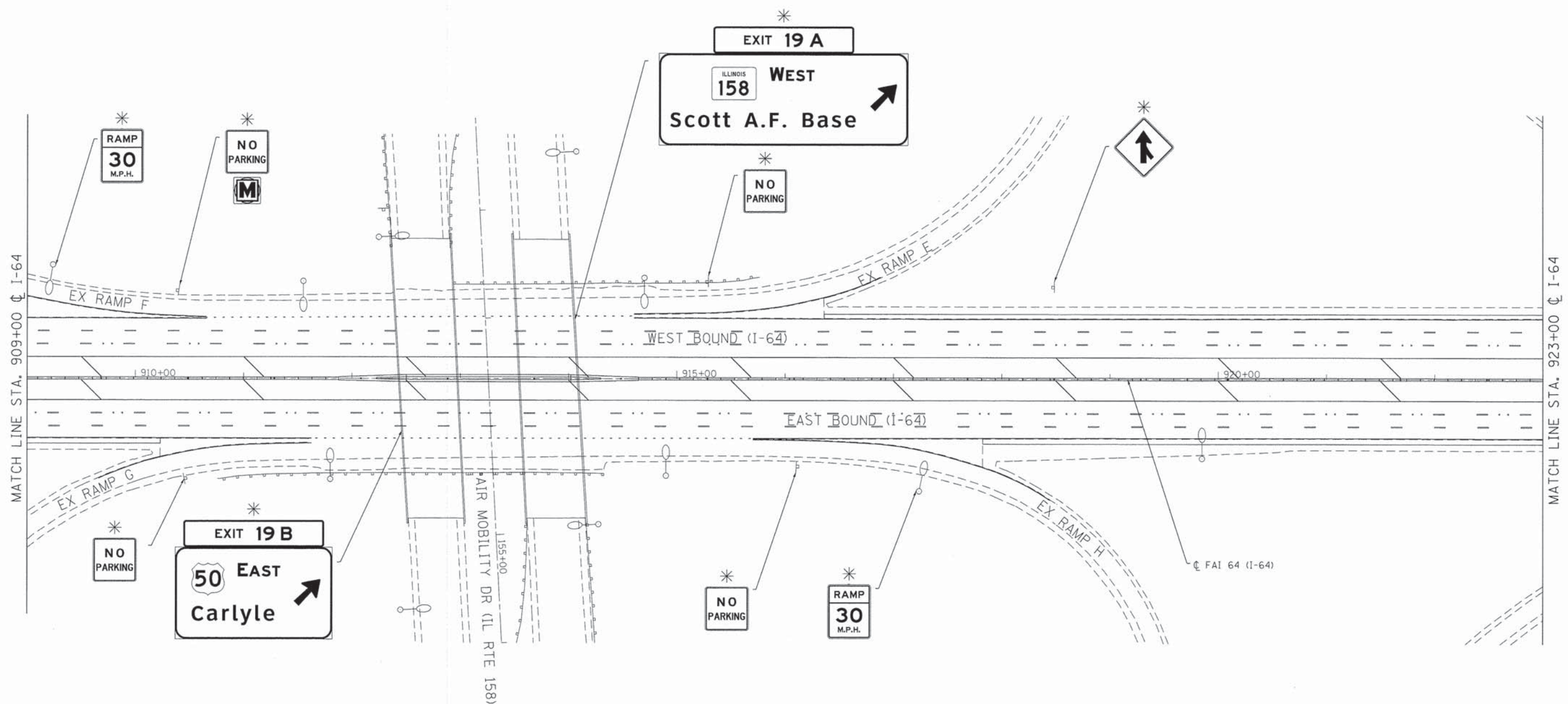
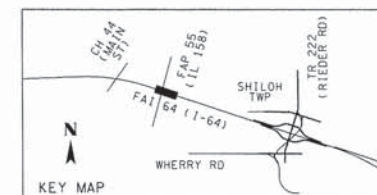

EXISTING SIGN TO BE REMOVED  
 EXISTING SIGN TO REMAIN

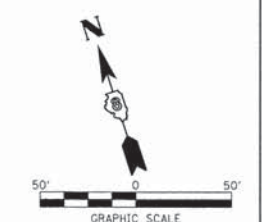

P:\09-0016-02\_Rieder\_Road\_Phase\_1\1118\_CADD\CADD\_Sheets\SP-0016-sh1-I-64\_Sign06.dgn

FILE NAME = 09-0016-sh1-I-64\_Sign06.dgn  
 USER NAME = IDOT  
 MODEL NAME = Default  
 PLOT SCALE = 600.0000' / ft.  
 PLOT DATE = 4/26/2014

DESIGNED - SMS  
 DRAWN - SMS  
 CHECKED - LDC  
 DATE - April 29, 2014

REVISED -  
 REVISED -  
 REVISED -  
 REVISED -

**STATE OF ILLINOIS**  
**DEPARTMENT OF TRANSPORTATION**

**SIGNING PLAN**  
**PROPOSED WIDENING FAI 64 (I-64)**  
 SCALE: 1" = 50'    SHEET NO. 6 OF 37 SHEETS    STA. 909+00 TO STA. 923+00

F.A.I. RTE.	SECTION	COUNTY	TOTAL SHEETS	SHEET NO.
64	09-00365-01-PV	ST. CLAIR	535	208
TR RTE. 222 (RIEDER ROAD)			CONTRACT NO. 97549	
ILLINOIS				





EXIT 19 A  
 WEST  
 Scott A.F. Base  
 NEXT RIGHT

EXIT 19 B  
 EAST  
 O'Fallon

STR NO 8S0821064L019.1  
 STA 931+02

RELOCATED SIGN ASSEMBLY  
 MOUNT ON SIGN TRUSS POST

RAMP  
 50  
 M.P.H.

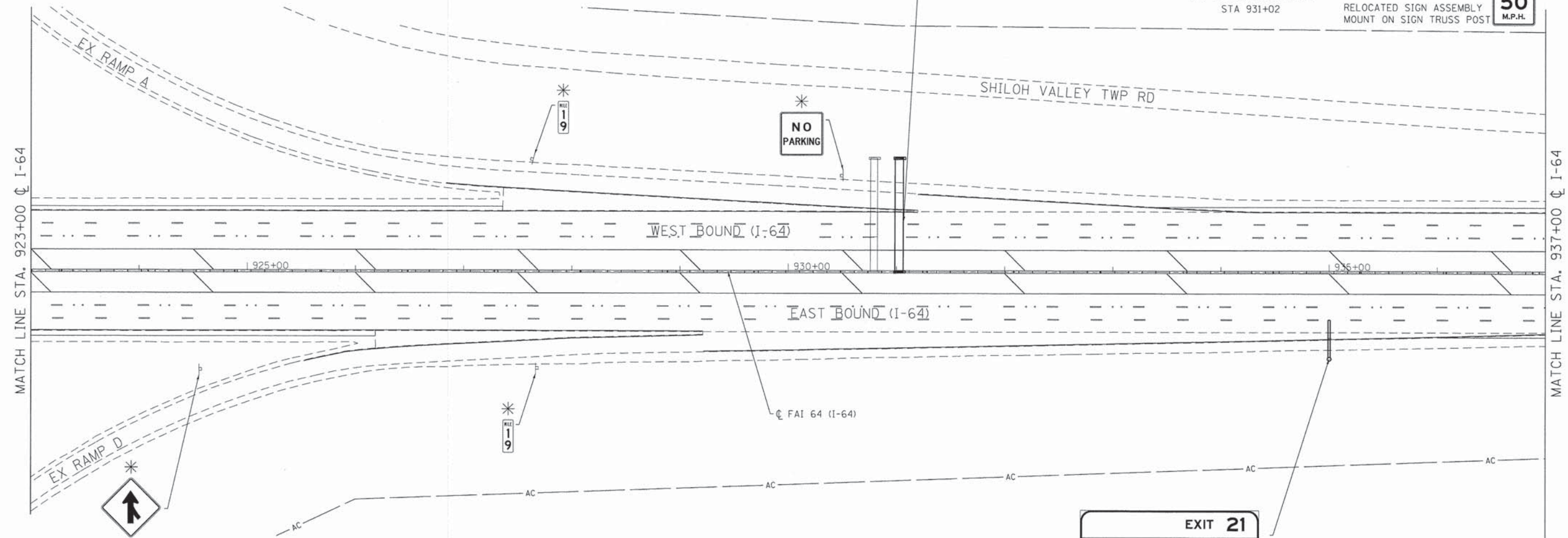

EXIT 21  
 Rieder Road  
 1 MILE  
 EXIT ↓ ONLY

STR NO 8C0821064R019.1  
 STA 935+00, 80.0' RT

☒ EXISTING SIGN TO BE REMOVED  
 \* EXISTING SIGN TO REMAIN

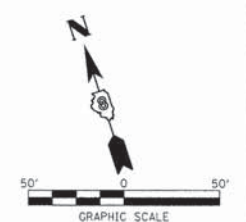

P:\09-2016-02 Rieder Road Phase I\118 CAD\CADD Sheets\09-2016-sht-1-64 Sign07.dgn

FILE NAME = 09-2016-sht-1-64 Sign07.dgn	USER NAME = IDOT	DESIGNED - SMS	REVISED -
	MODEL NAME = Default	DRAWN - SMS	REVISED -
	PLOT SCALE = 600.0000' / ft.	CHECKED - LDC	REVISED -
	PLOT DATE = 4/26/2014	DATE - April 29, 2014	REVISED -

**STATE OF ILLINOIS  
 DEPARTMENT OF TRANSPORTATION**

**SIGNING PLAN  
 PROPOSED WIDENING FAI 64 (I-64)**

SCALE: 1" = 50'    SHEET NO. 7 OF 37 SHEETS    STA. 923+00 TO STA. 937+00

F.A.I. RTE.	SECTION	COUNTY	TOTAL SHEETS	SHEET NO.
64	09-00365-01-PV	ST. CLAIR	535	209
TR RTE. 222 (RIEDER ROAD)			CONTRACT NO. 97549	
ILLINOIS				

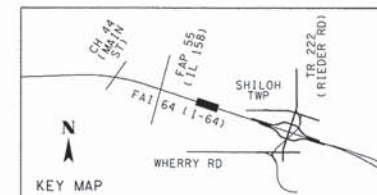

STA 940+00, 87.4' LT  
RELOCATED FROM STA 991+78

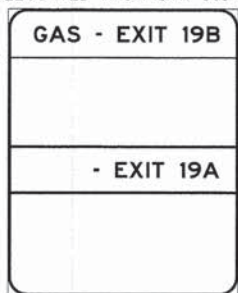

STA 948+00, 96.8' LT



STA 948+00, 99' LT

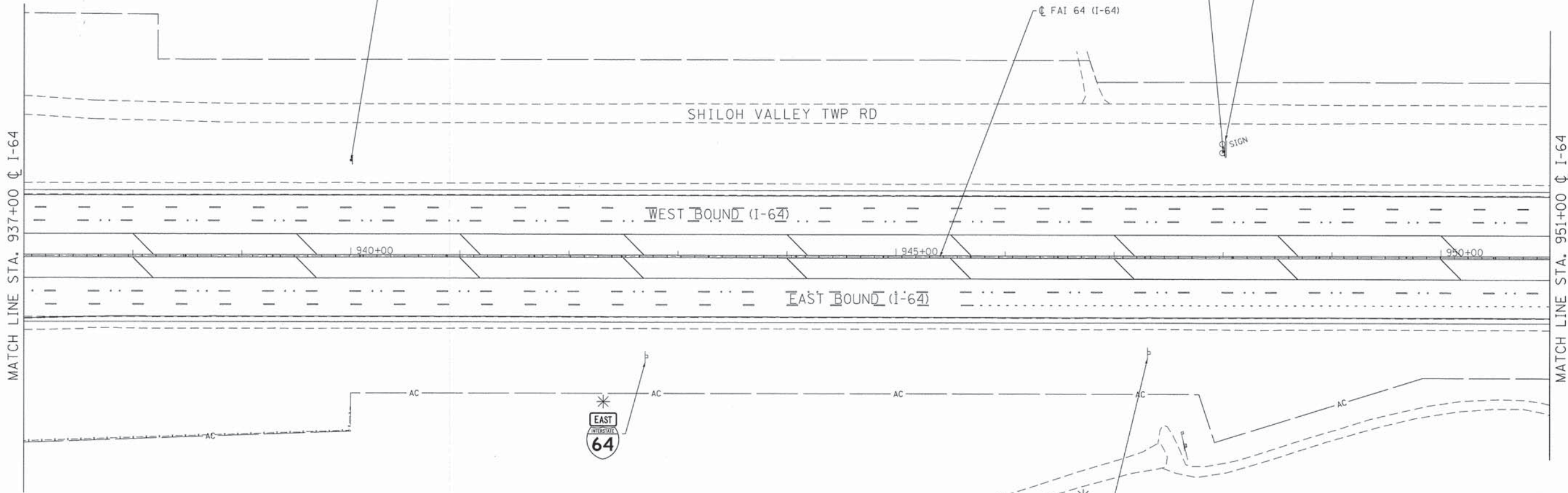

⊗ EXISTING SIGN TO BE REMOVED  
\* EXISTING SIGN TO REMAIN

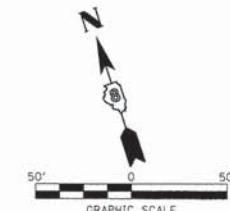

P:\09-0016\02\_Rieder\_Road\_Phase\_1\1\10\_CAD\CADD\_Sheets\09-0016-sht-1-64\_Sign08.dgn

FILE NAME = 09-0016-sht-1-64_Sign08.dgn	USER NAME = IDDT	DESIGNED - SMS	REVISED -
	MODEL NAME = Default	DRAWN - SMS	REVISED -
	PLOT SCALE = 600.0000' / Ft.	CHECKED - LDC	REVISED -
	PLOT DATE = 4/26/2014	DATE - April 29, 2014	REVISED -

**STATE OF ILLINOIS  
DEPARTMENT OF TRANSPORTATION**

**SIGNING PLAN  
PROPOSED WIDENING FAI 64 (I-64)**

SCALE: 1" = 50'    SHEET NO. 8 OF 37 SHEETS    STA. 937+00 TO STA. 951+00

F.A.I. RTE.	SECTION	COUNTY	TOTAL SHEETS	SHEET NO.
64	09-00365-01-PV	ST. CLAIR	535	210
TR RTE. 222 (RIEDER ROAD)			CONTRACT NO. 97549	
ILLINOIS				

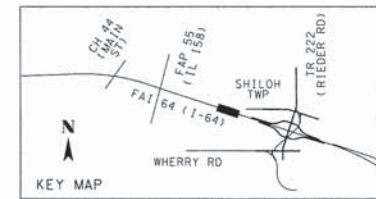

STA 955+00, 98.9' LT  
RELOCATED FROM STA 1009+89

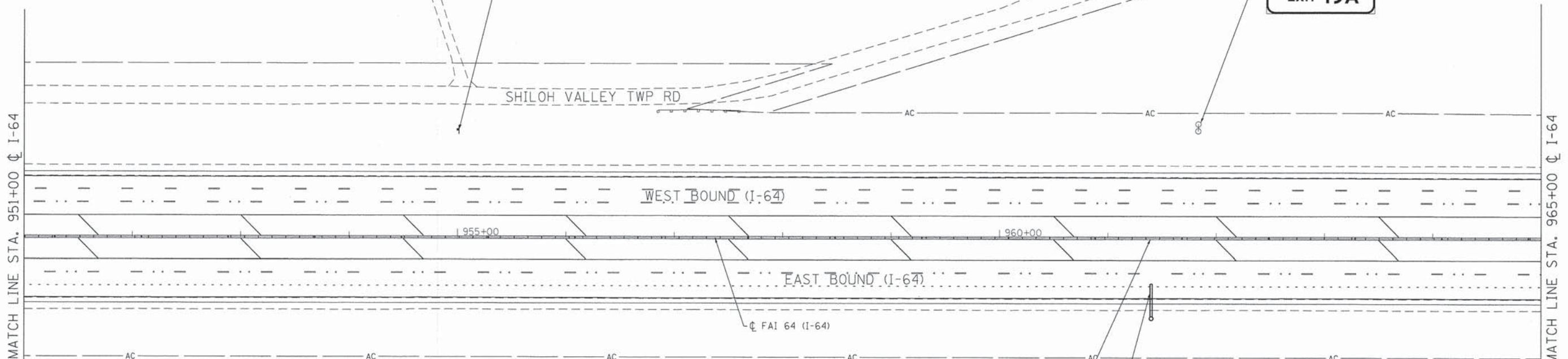
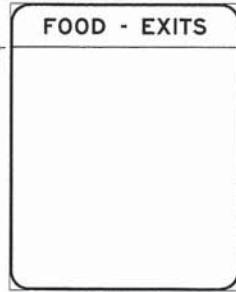

961+40, 0' RT

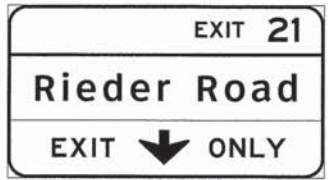

STR NO 8C0821064R019.6  
STA 961+40, 73.6' RT

☒ EXISTING SIGN TO BE REMOVED  
\* EXISTING SIGN TO REMAIN

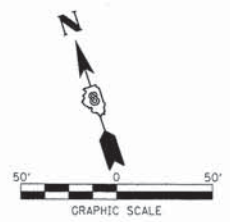

P:\99-0016\02\_Rieder\_Road\_Phase\_II\10\_CADD\03\_Sheets\99-0016-shr-1-64\_Sign09.dgn

FILE NAME = 09-0016-shr-1-64_Sign09.dgn	USER NAME = IDOT	DESIGNED - SMS	REVISED -
	MODEL NAME = Default	DRAWN - SMS	REVISED -
	PLOT SCALE = 600.0000' / ft.	CHECKED - LDC	REVISED -
	PLOT DATE = 4/26/2014	DATE - April 29, 2014	REVISED -

**STATE OF ILLINOIS  
DEPARTMENT OF TRANSPORTATION**

**SIGNING PLAN  
PROPOSED WIDENING FAI 64 (I-64)**

SCALE: 1" = 50'    SHEET NO. 9 OF 37 SHEETS    STA. 951+00 TO STA. 965+00

F.A.I. RTE.	SECTION	COUNTY	TOTAL SHEETS	SHEET NO.
64	09-00365-01-PV	ST. CLAIR	535	211
TR RTE. 222 (RIEDER ROAD)			CONTRACT NO. 97549	
ILLINOIS				

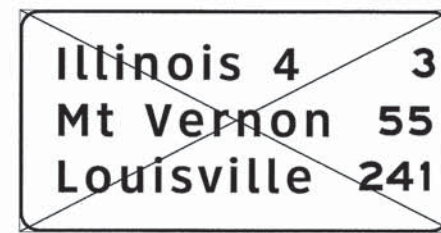
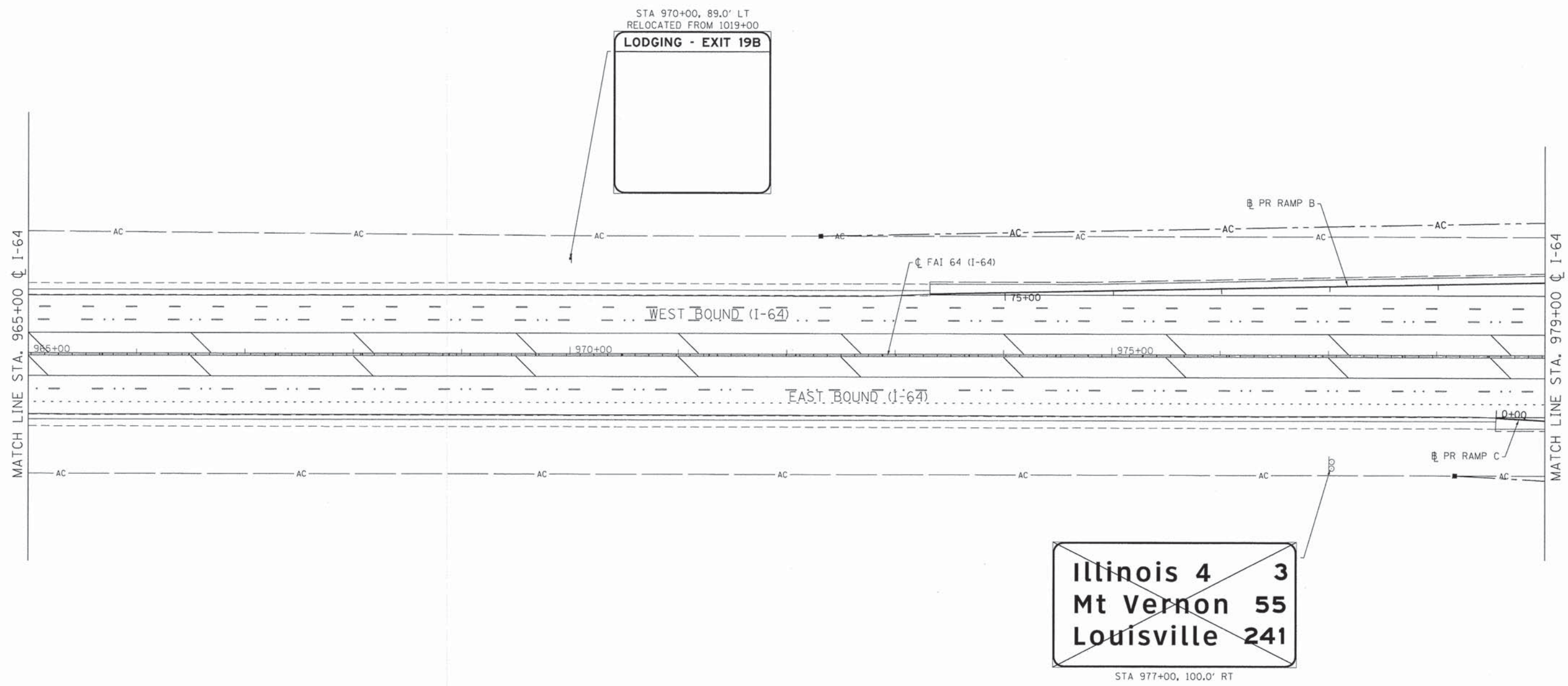
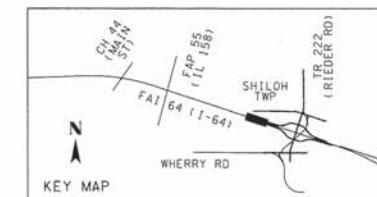

☒ EXISTING SIGN TO BE REMOVED  
\* EXISTING SIGN TO REMAIN

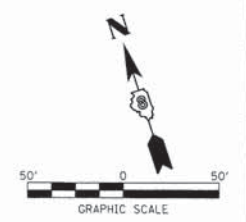

P:\09-0016-02 Rieder Road Phase 1\10 CAD\CADD Sheets\09-0016-sht-1-64 Sign10.dgn

FILE NAME = 09-0016-sht-1-64 Sign10.dgn	USER NAME = IDOT	DESIGNED - SMS	REVISED - -
	MODEL NAME = Default	DRAWN - SMS	REVISED - -
	PLOT SCALE = 600,0000' / ft.	CHECKED - LDC	REVISED - -
	PLOT DATE = 4/26/2014	DATE - Apr 29, 2014	REVISED - -

**STATE OF ILLINOIS  
DEPARTMENT OF TRANSPORTATION**

**SIGNING PLAN  
PROPOSED WIDENING FAI 64 (I-64)**

SCALE: 1" = 50'    SHEET NO. 10 OF 37 SHEETS    STA. 965+00    TO STA. 979+00

F.A.I. RTE.	SECTION	COUNTY	TOTAL SHEETS	SHEET NO.
64	09-00365-01-PV	ST. CLAIR	535	212
TR RTE. 222 (RIEDER ROAD)			CONTRACT NO. 97549	
ILLINOIS				

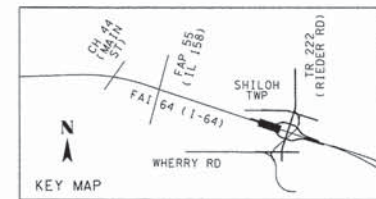

STA 991+78, 94' LT  
RELOCATE TO STA 940+00, 87.4' LT

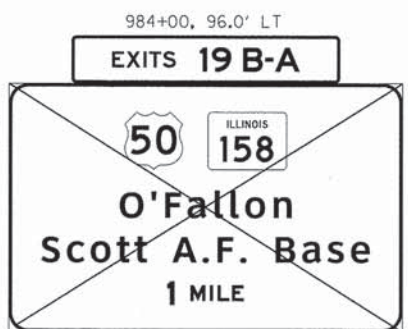
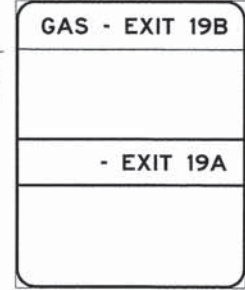

STA 980+48, 67' LT  
RELOCATE IN ACCORDANCE  
WITH STANDARD 720006

STA 980+53, 71' RT  
RELOCATE IN ACCORDANCE  
WITH STANDARD 720006

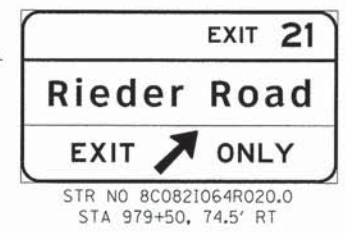
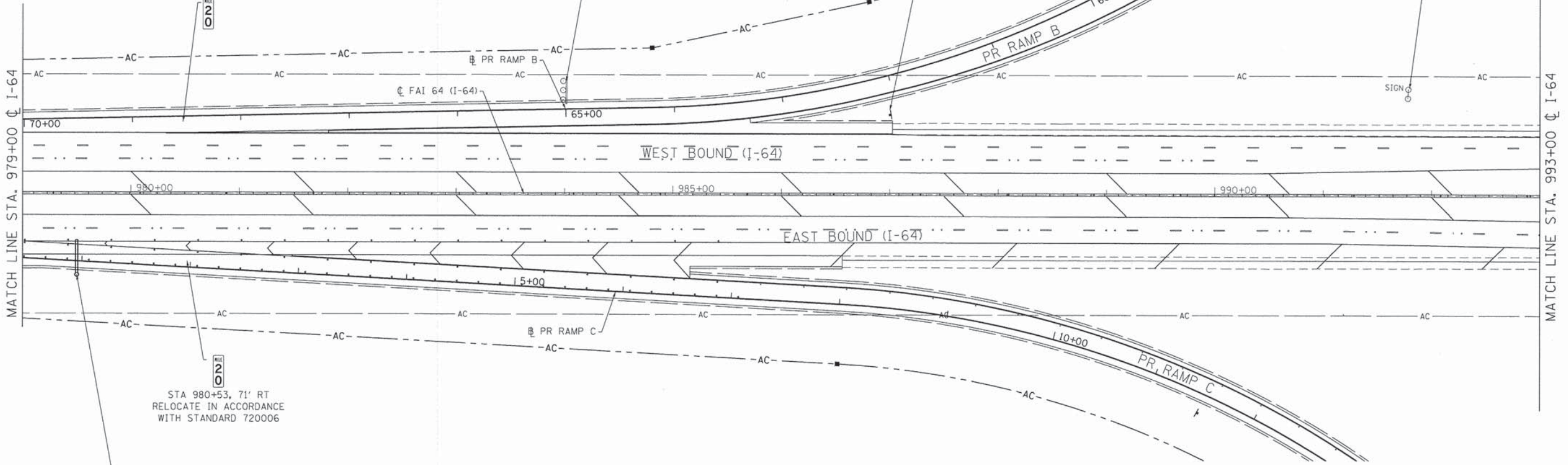

☒ EXISTING SIGN TO BE REMOVED  
\* EXISTING SIGN TO REMAIN

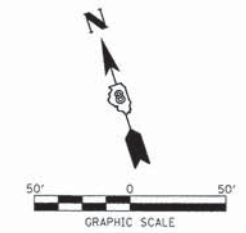

F:\Bt-001602\_Rieder\_Road\_Phase\_1\110\_CAD\CADD\_Sheets\VR-0016-sh1-1-64\_Sign1.dgn

FILE NAME = 09-0016-sh1-1-64_Sign1.dgn	USER NAME = IDOT	DESIGNED - SMS	REVISED - -
MODEL NAME = Default	DRAWN - SMS	CHECKED - LDC	REVISED - -
PLOT SCALE = 600.0000 1/ Ft.	DATE - Apr 29, 2014	REVISED - -	REVISED - -

**STATE OF ILLINOIS  
DEPARTMENT OF TRANSPORTATION**

**SIGNING PLAN  
PROPOSED WIDENING FAI 64 (I-64)**

SCALE: 1" = 50'    SHEET NO. 11 OF 37 SHEETS    STA. 979+00 TO STA. 993+00

F.A.I. RTE.	SECTION	COUNTY	TOTAL SHEETS	SHEET NO.
64	09-00365-01-PV	ST. CLAIR	535	213
TR RTE. 222 (RIEDER ROAD)		CONTRACT NO. 97549		
[ILLINOIS]				

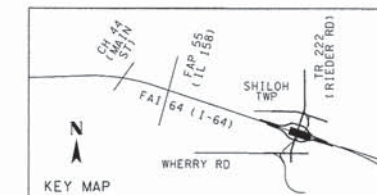

STR NO 8B082I064L020.4  
STA 998+40, 39.0' LT

**EXIT 19 B-A**

**50** ILLINOIS **158**

**O'Fallon  
Scott A.F. Base**

**1 MILE**

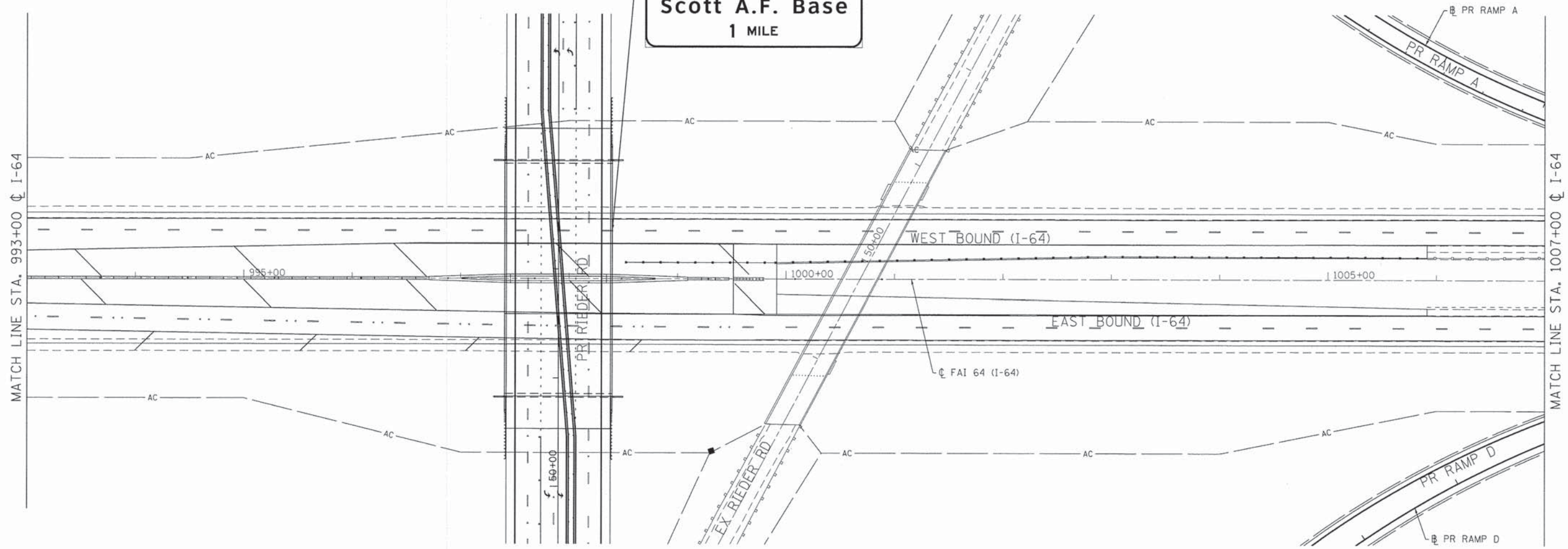

- ☒ EXISTING SIGN TO BE REMOVED
- \* EXISTING SIGN TO REMAIN

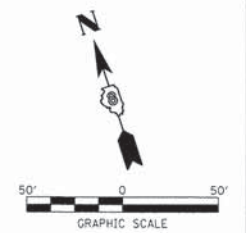

P:\09-2016\09-2016-Road Phase - I-64\CADD\CADD Sheets\09-2016-sht-I-64\_Sign12.dgn

FILE NAME = 09-2016-sht-I-64_Sign12.dgn	USER NAME = ID07	DESIGNED - SMS	REVISED -
MODEL NAME = Default	DRAWN - SMS	CHECKED - LDC	REVISED -
PLOT SCALE = 600.0000' / ft.	DATE - Apr 29, 2014		

**STATE OF ILLINOIS  
DEPARTMENT OF TRANSPORTATION**

**SIGNING PLAN**  
**PROPOSED WIDENING FAI 64 (I-64)**

SCALE: 1" = 50'    SHEET NO. 12 OF 37 SHEETS    STA. 993+00 TO STA. 1007+00

F.A.I. RTE.	SECTION	COUNTY	TOTAL SHEETS	SHEET NO.
64	09-00365-01-PV	ST. CLAIR	535	214
TR RTE. 222 (RIEDER ROAD)			CONTRACT NO. 97549	
ILLINOIS				

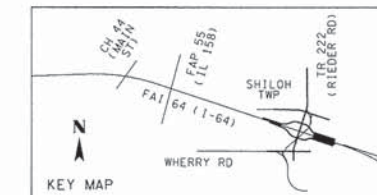

STA 1009+89, 86' LT  
RELOCATE TO STA 955+00, 98.9' LT

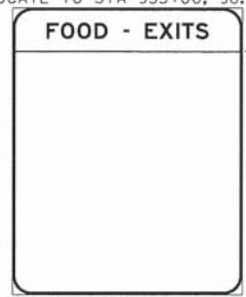

STA 1019+00, 98' LT  
RELOCATE TO STA 970+00, 89.0' LT

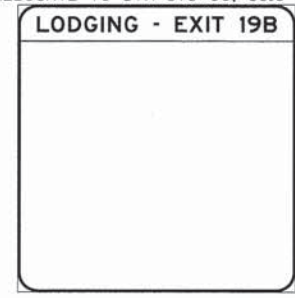

STA 1018+00, 90.9' LT

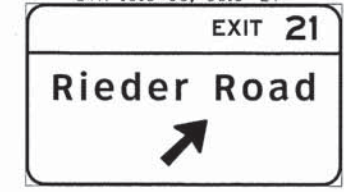

STA 1020+00, 99.7' RT

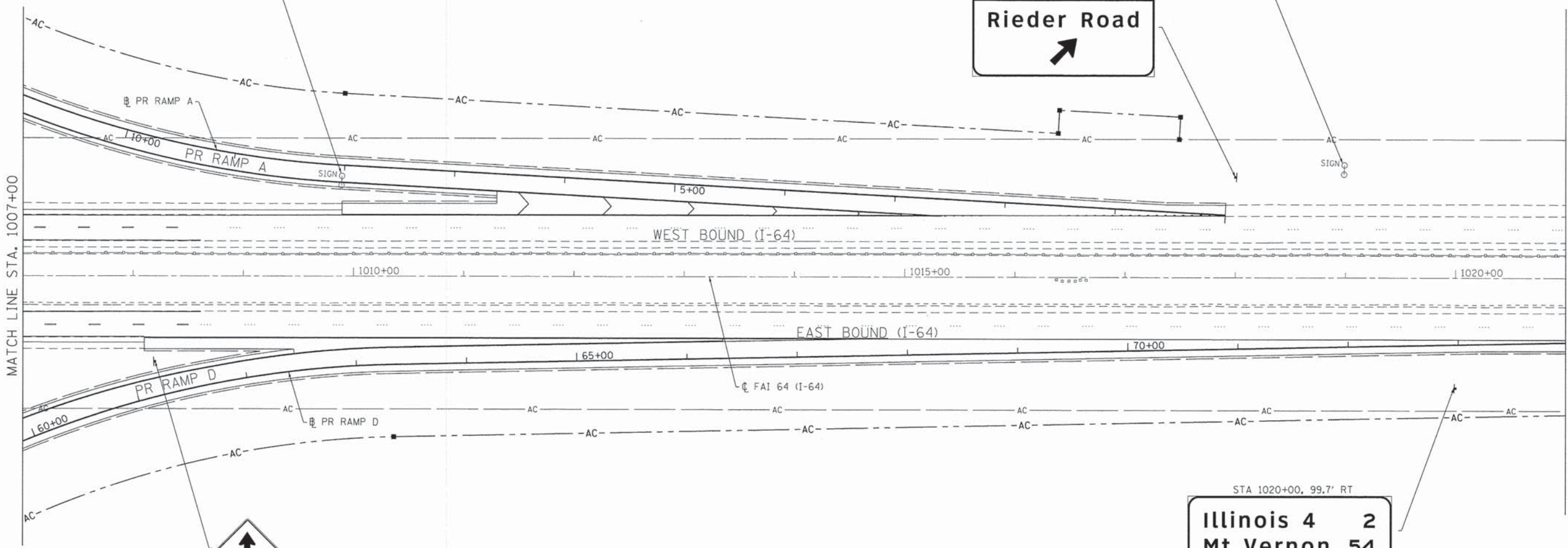
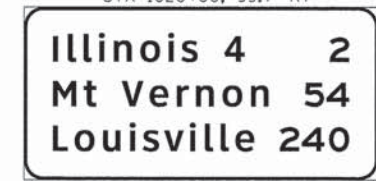

W4-1  
STA 1008+20, 77.3' RT



☒ EXISTING SIGN TO BE REMOVED  
\* EXISTING SIGN TO REMAIN

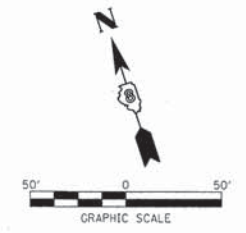

P:\09-0016-02 Rieder Road Phase II\10.LAND\ADD Sheets\09-0016-sh1-64\_Sign13.dgn

FILE NAME =	09-0016-sh1-64_Sign13.dgn
USER NAME =	IDOT
MODEL NAME =	Default
PLOT SCALE =	600.0000' / ft.
PLOT DATE =	4/26/2014

DESIGNED -	SMS
DRAWN -	SMS
CHECKED -	LDC
DATE -	April 29, 2014

REVISED -	
REVISED -	
REVISED -	
REVISED -	

**STATE OF ILLINOIS  
DEPARTMENT OF TRANSPORTATION**

**SIGNING PLAN  
PROPOSED WIDENING FAI 64 (I-64)**  
SCALE: 1" = 50' SHEET NO. 13 OF 37 SHEETS STA. 1007+00 TO STA. 1021+00

F.A.I. RTE.	SECTION	COUNTY	TOTAL SHEETS	SHEET NO.
64	09-00365-01-PV	ST. CLAIR	535	215
TR RTE. 222 (RIEDER ROAD)		CONTRACT NO. 97549		
ILLINOIS				

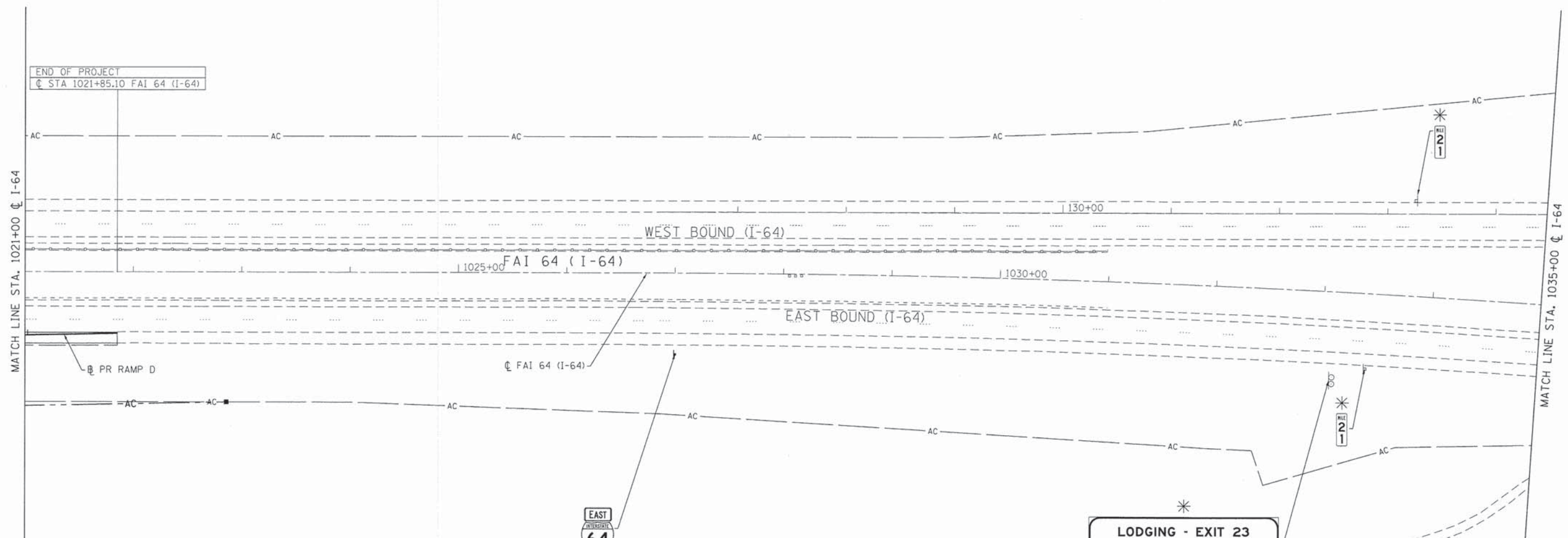
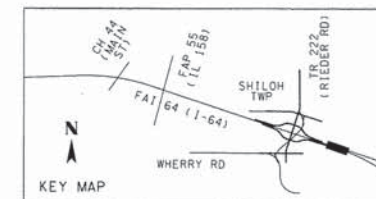

END OF PROJECT  
 ☉ STA 1021+85.10 FAI 64 (I-64)

MATCH LINE STA. 1021+00 ☉ I-64

MATCH LINE STA. 1035+00 ☉ I-64

WEST BOUND (I-64)

EAST BOUND (I-64)

FAI 64 (I-64)

☉ FAI 64 (I-64)

PR RAMP D



MI-1 & M3-2  
 STA 1027+00, 75.1' RT

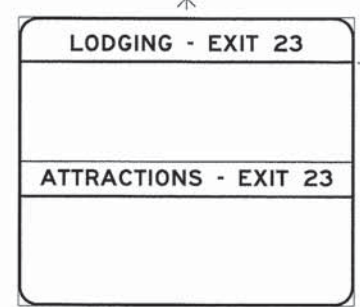

☒ EXISTING SIGN TO BE REMOVED  
 \* EXISTING SIGN TO REMAIN

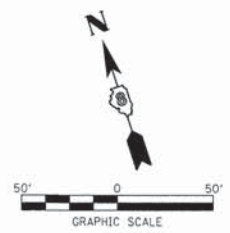

P:\09-0016\02\_Road\Road Phase\11\10\_CAD\CADD\_Sheet\09-0016-sht-1-64\_Sign1.dgn

FILE NAME = 09-0016-sht-1-64_Sign1.dgn	USER NAME = IDDT	DESIGNED - SMS	REVISED - -
	MODEL NAME = Default	DRAWN - SMS	REVISED - -
	PLOT SCALE = 600.0000' / ft.	CHECKED - LDC	REVISED - -
	PLOT DATE = 4/26/2014	DATE - April 29, 2014	REVISED - -

**STATE OF ILLINOIS  
 DEPARTMENT OF TRANSPORTATION**

**SIGNING PLAN  
 PROPOSED WIDENING FAI 64 (I-64)**

SCALE: 1" = 50'    SHEET NO. 14 OF 37 SHEETS    STA. 1021+00 TO STA. 1035+00

F.A.I. RTE.	SECTION	COUNTY	TOTAL SHEETS	SHEET NO.
64	09-00365-01-PV	ST. CLAIR	535	216
TR RTE. 222 (RIEDER ROAD)		ILLINOIS	CONTRACT NO. 97549	



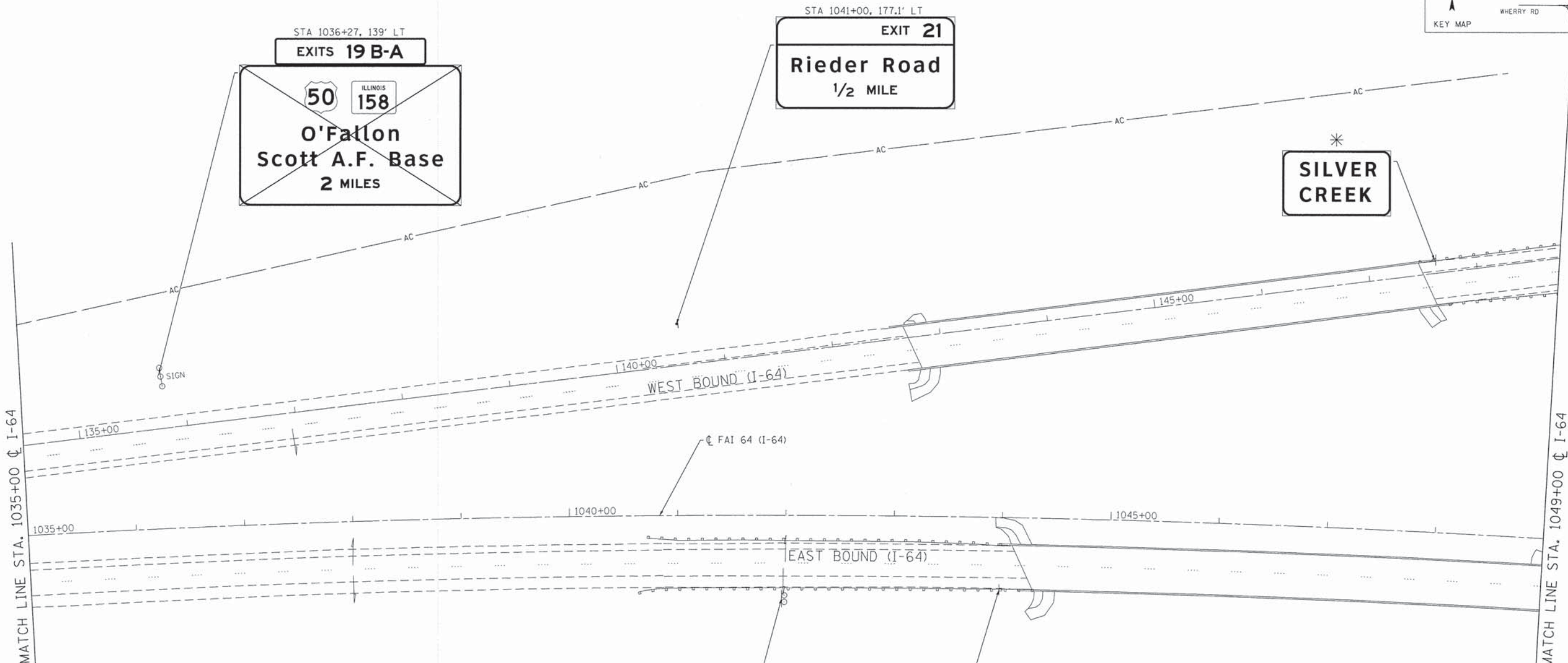
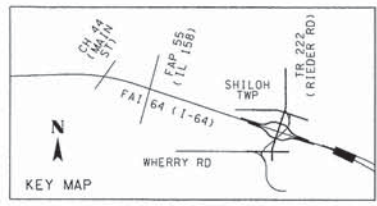

STA 1036+27, 139' LT  
**EXITS 19B-A**  
 50 ILLINOIS 158  
**O'Fallon  
 Scott A.F. Base  
 2 MILES**

STA 1041+00, 177.1' LT  
**EXIT 21**  
**Rieder Road**  
 1/2 MILE

\*  
**SILVER CREEK**

\*  
**GAS - EXIT 23**  
 \_\_\_\_\_  
**FOOD - EXIT 23**  
 \_\_\_\_\_

\*  
**SILVER CREEK**

☒ EXISTING SIGN TO BE REMOVED  
 \* EXISTING SIGN TO REMAIN

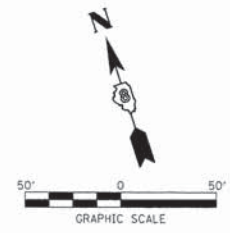

P:\09-0016-02 Rieder Road Phase I\10 CAD\CADD Sheets\09-0016-sht-1-64 Sign15.dgn

FILE NAME = 09-0016-sht-1-64 Sign15.dgn	USER NAME = IDOT	DESIGNED - SMS	REVISED -
	MODEL NAME = Default	DRAWN - SMS	REVISED -
	PLOT SCALE = 600.0000' / ft.	CHECKED - LDC	REVISED -
	PLOT DATE = 4/26/2014	DATE - April 29, 2014	REVISED -

**STATE OF ILLINOIS  
 DEPARTMENT OF TRANSPORTATION**

**SIGNING PLAN  
 PROPOSED WIDENING FAI 64 (I-64)**

SCALE: 1" = 50'    SHEET NO. 15 OF 37 SHEETS    STA. 1035+00 TO STA. 1049+00

F.A.I. RTE.	SECTION	COUNTY	TOTAL SHEETS	SHEET NO.
64	09-00365-01-PV	ST. CLAIR	535	217
TR RTE. 222 (RIEDER ROAD)			CONTRACT NO. 97549	
ILLINOIS				

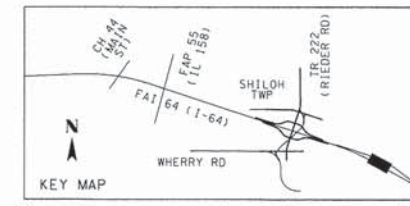

STA 1054+56, 359.0' LT  
**O'Fallon**  
 Next 3 Exits

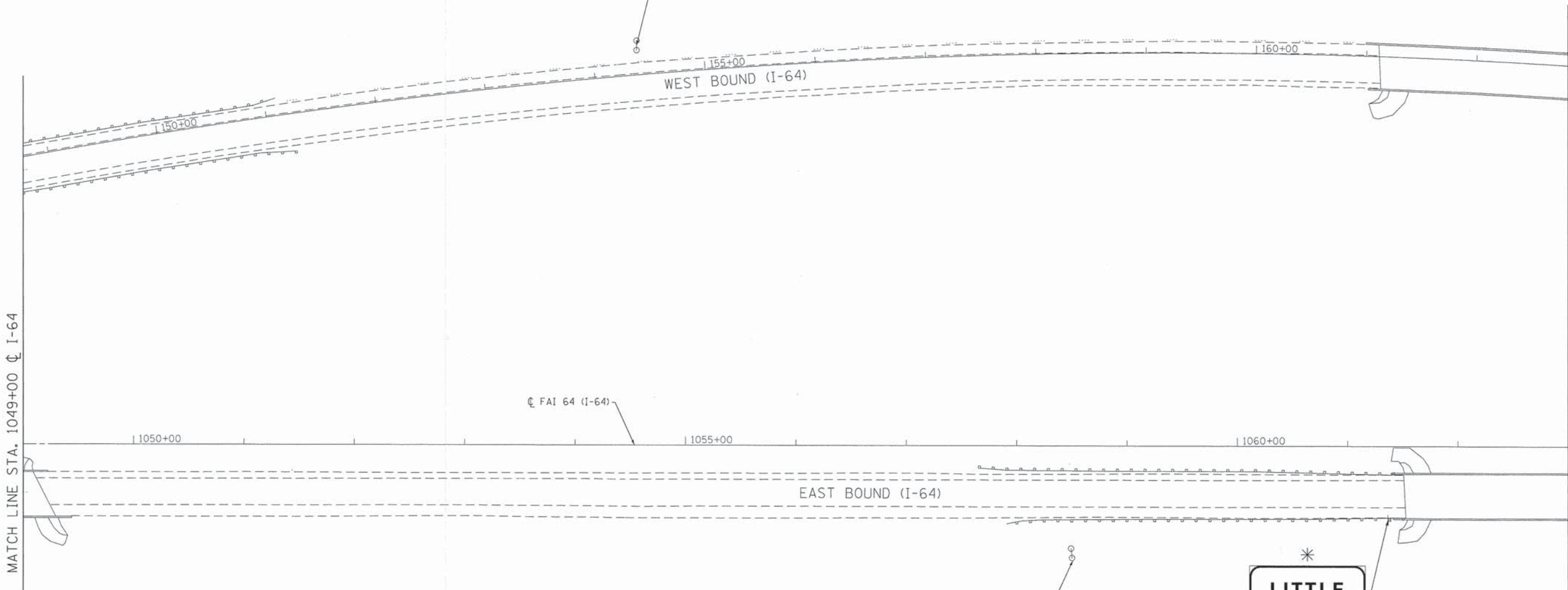

EXIT 23  
 ILLINOIS  
**4**  
**Mascoutah**  
**Lebanon**  
 1 MILE

**LITTLE SILVER CREEK**

☒ EXISTING SIGN TO BE REMOVED  
 \* EXISTING SIGN TO REMAIN

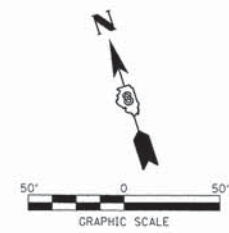

P:\09-0016-02\_Rieder\_Road\_Phase\_1\119\_CADD\CADD\_Sheets\09-0016-02-1-64\_Sign16.dgn

FILE NAME = 09-0016-02-1-64_Sign16.dgn	USER NAME = 100T	DESIGNED - SMS	REVISED - -
MODEL NAME = Default	DRAWN - SMS	CHECKED - LDC	REVISED - -
PLOT SCALE = 600,0000' / Ft.	DATE - April 29, 2014		

**STATE OF ILLINOIS**  
**DEPARTMENT OF TRANSPORTATION**

**SIGNING PLAN**  
**PROPOSED WIDENING FAI 64 (I-64)**  
 SCALE: 1" = 50'    SHEET NO. 16 OF 37 SHEETS    STA. 1049+00 TO STA. 1063+00

F.A.I. RTE.	SECTION	COUNTY	TOTAL SHEETS	SHEET NO.
64	09-00365-01-PV	ST. CLAIR	535	218
TR RTE. 222 (RIEDER ROAD)			CONTRACT NO. 97549	
ILLINOIS				

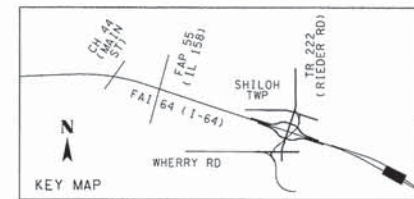

Illinois 158	3
East St Louis	20
St Louis	23

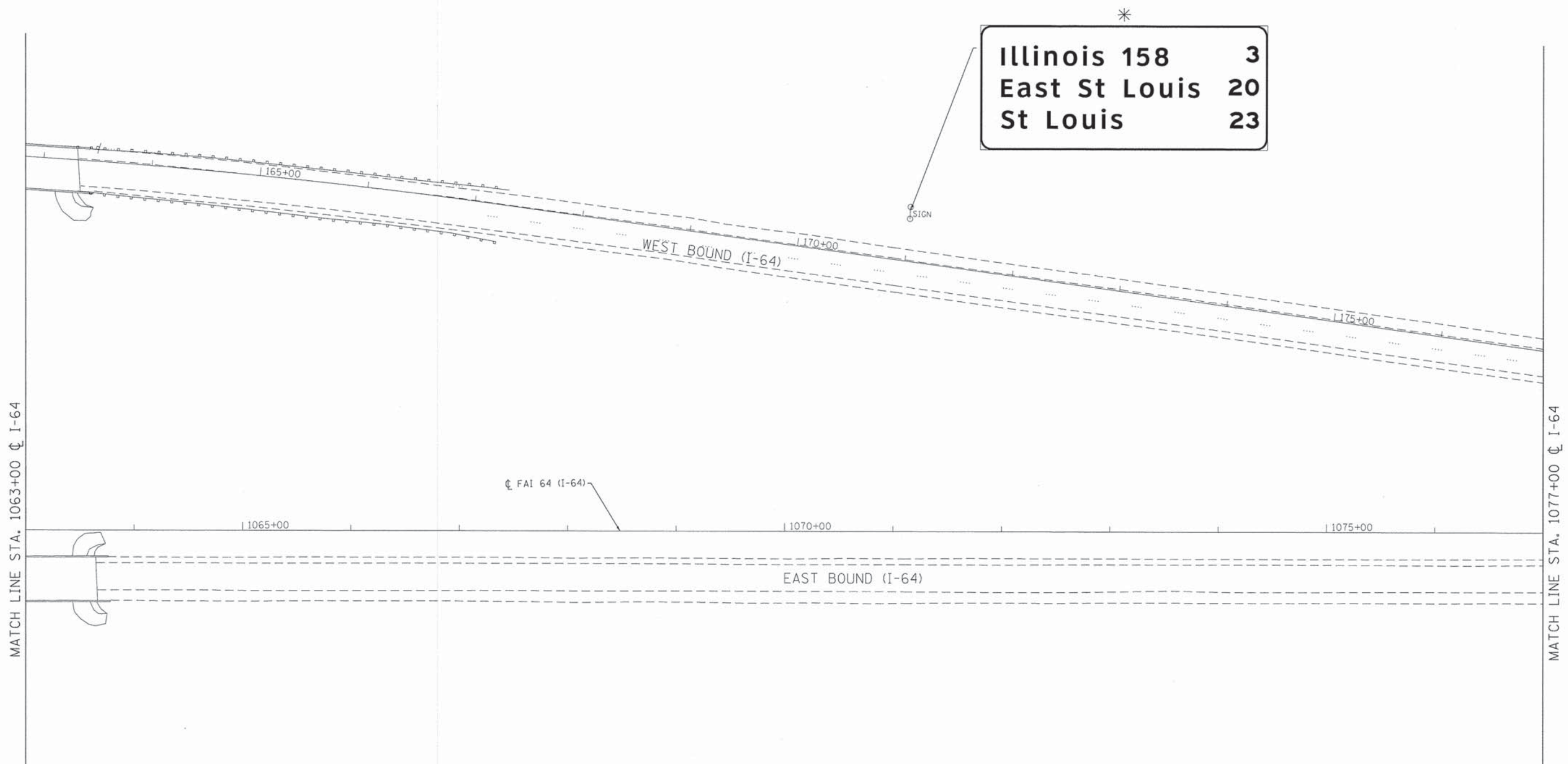

- ☒ EXISTING SIGN TO BE REMOVED
- \* EXISTING SIGN TO REMAIN

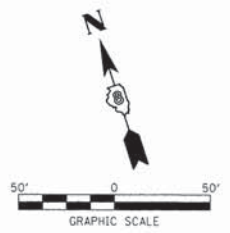

P:\09-0016-02 Rieder Road Phase I\10-00\CA000 Sheets\09-0016-sht-1-64\_Sign17.dgn

FILE NAME = 09-0016-sht-1-64_Sign17.dgn	USER NAME = IDOT	DESIGNED - SMS	REVISED -
	MODEL NAME = Default	DRAWN - SMS	REVISED -
	PLOT SCALE = 600.0000' / ft.	CHECKED - LDC	REVISED -
	PLOT DATE = 4/26/2014	DATE - April 29, 2014	REVISED -

**STATE OF ILLINOIS  
DEPARTMENT OF TRANSPORTATION**

**SIGNING PLAN  
PROPOSED WIDENING FAI 64 (I-64)**

SCALE: 1" = 50'    SHEET NO. 17 OF 37 SHEETS    STA. 1063+00 TO STA. 1077+00

F.A.I. RTE.	SECTION	COUNTY	TOTAL SHEETS	SHEET NO.
64	09-00365-01-PV	ST. CLAIR	535	219
TR RTE. 222 (RIEDER ROAD)			CONTRACT NO. 97549	
ILLINOIS				

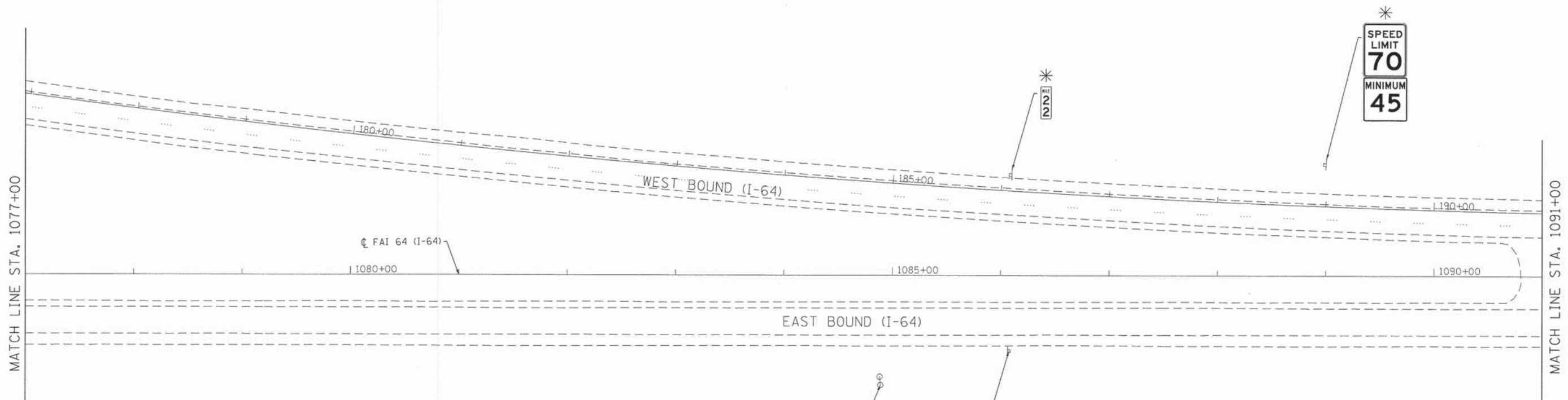
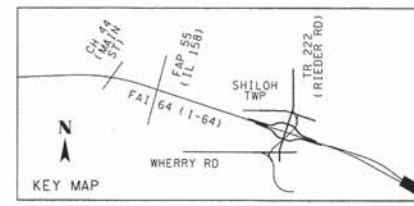

\*  
SPEED LIMIT  
**70**  
MINIMUM  
**45**

\*  
EXIT **23**  
ILLINOIS  
**4**  
Mascoutah  
Lebanon  
1/2 MILE

\*  
RET  
**22**

☒ EXISTING SIGN TO BE REMOVED  
\* EXISTING SIGN TO REMAIN

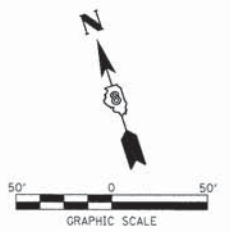

F:\09-0016\02 Rieder Road Phase II\IB\CAD\CADD Sheets\09-0016-sht-1-64\_Sign1B.dgn

FILE NAME = 09-0016-sht-1-64_Sign1B.dgn	USER NAME = IDOT	DESIGNED - SMS	REVISED -
	MODEL NAME = Default	DRAWN - SMS	REVISED -
	PLOT SCALE = 600.0000' / ft.	CHECKED - LDC	REVISED -
	PLOT DATE = 4/26/2014	DATE - April 29, 2014	REVISED -

**STATE OF ILLINOIS  
DEPARTMENT OF TRANSPORTATION**

**SIGNING PLAN  
PROPOSED WIDENING FAI 64 (I-64)**  
SCALE: 1" = 50' SHEET NO. 18 OF 37 SHEETS STA. 1077+00 TO STA. 1091+00

F.A.I. RTE.	SECTION	COUNTY	TOTAL SHEETS	SHEET NO.
64	09-00365-01-PV	ST. CLAIR	535	220
TR RTE. 222 (RIEDER ROAD)			CONTRACT NO. 97549	
ILLINOIS				

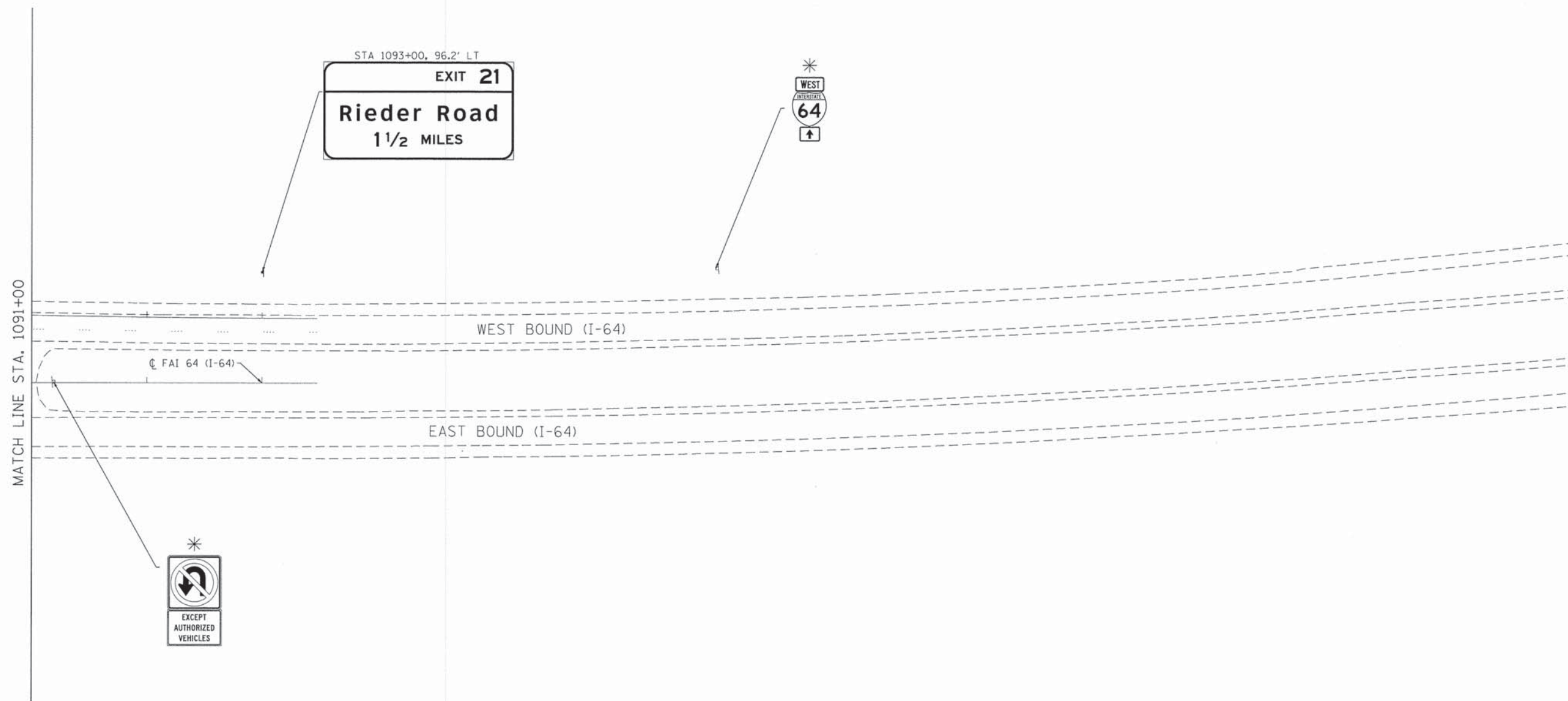
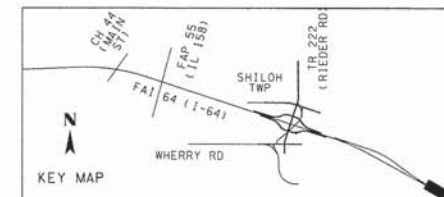

EXISTING SIGN TO BE REMOVED  
 EXISTING SIGN TO REMAIN

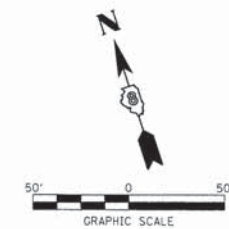

P:\09-0016\02 Rieder Road Phase I\118.CAD\CADD\_Sheets\09-0016-sh1-1-64\_Sign18a.dgn

FILE NAME = 09-0016-sh1-1-64_Sign18a.dgn	USER NAME = IDOT	DESIGNED - SMS	REVISED -
	MODEL NAME = Default	DRAWN - SMS	REVISED -
	PLOT SCALE = 50,0000' / in.	CHECKED - LDC	REVISED -
	PLOT DATE = 4/26/2014	DATE - April 29, 2014	REVISED -

**STATE OF ILLINOIS**  
**DEPARTMENT OF TRANSPORTATION**

**SIGNING PLAN**  
**PROPOSED WIDENING FAI 64 (I-64)**

SCALE: 1" = 50'    SHEET NO. 19 OF 37 SHEETS    STA. 1077+00 TO STA. 1091+00

F.A.I. RTE.	SECTION	COUNTY	TOTAL SHEETS	SHEET NO.
64	09-00365-01-PV	ST. CLAIR	535	221
TR RTE. 222 (RIEDER ROAD)			CONTRACT NO. 97549	
ILLINOIS				

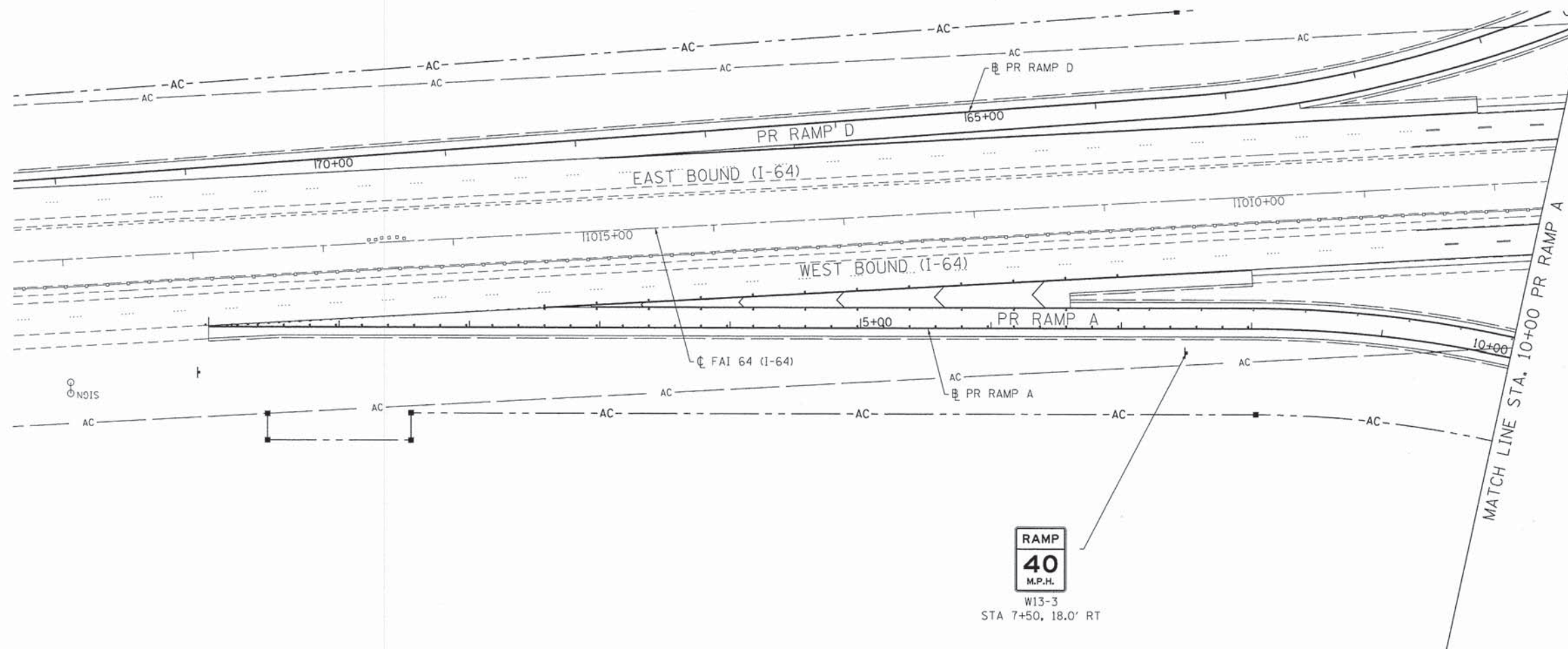
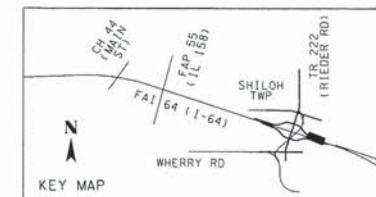

RAMP  
40  
M.P.H.  
W13-3  
STA 7+50, 18.0' RT

☒ EXISTING SIGN TO BE REMOVED  
\* EXISTING SIGN TO REMAIN

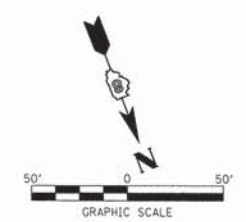

P:\gts\081622\_Rieder\_Road\_Phase1\1118\_CAD\CADD\_Sheets\09-00365-sht-1-64\_Sign1.dgn

FILE NAME = 09-00365-sht-1-64_Sign1.dgn	USER NAME = IDOT	DESIGNED - SMS	REVISED - -
	MODEL NAME = Default	DRAWN - SMS	REVISED - -
	PLOT SCALE = 600.0000' / ft.	CHECKED - LDC	REVISED - -
	PLOT DATE = 4/26/2014	DATE - April 29, 2014	REVISED - -

**STATE OF ILLINOIS  
DEPARTMENT OF TRANSPORTATION**

**SIGNING PLAN  
PROPOSED RAMP A**

SCALE: 1" = 50'    SHEET NO. 20 OF 37 SHEETS    STA. 0+00    TO STA. 10+00

F.A.I. RTE.	SECTION	COUNTY	TOTAL SHEETS	SHEET NO.
64	09-00365-01-PV	ST. CLAIR	535	222
TR RTE. 222 (RIEDER ROAD)			CONTRACT NO. 97549	
[ILLINOIS]				

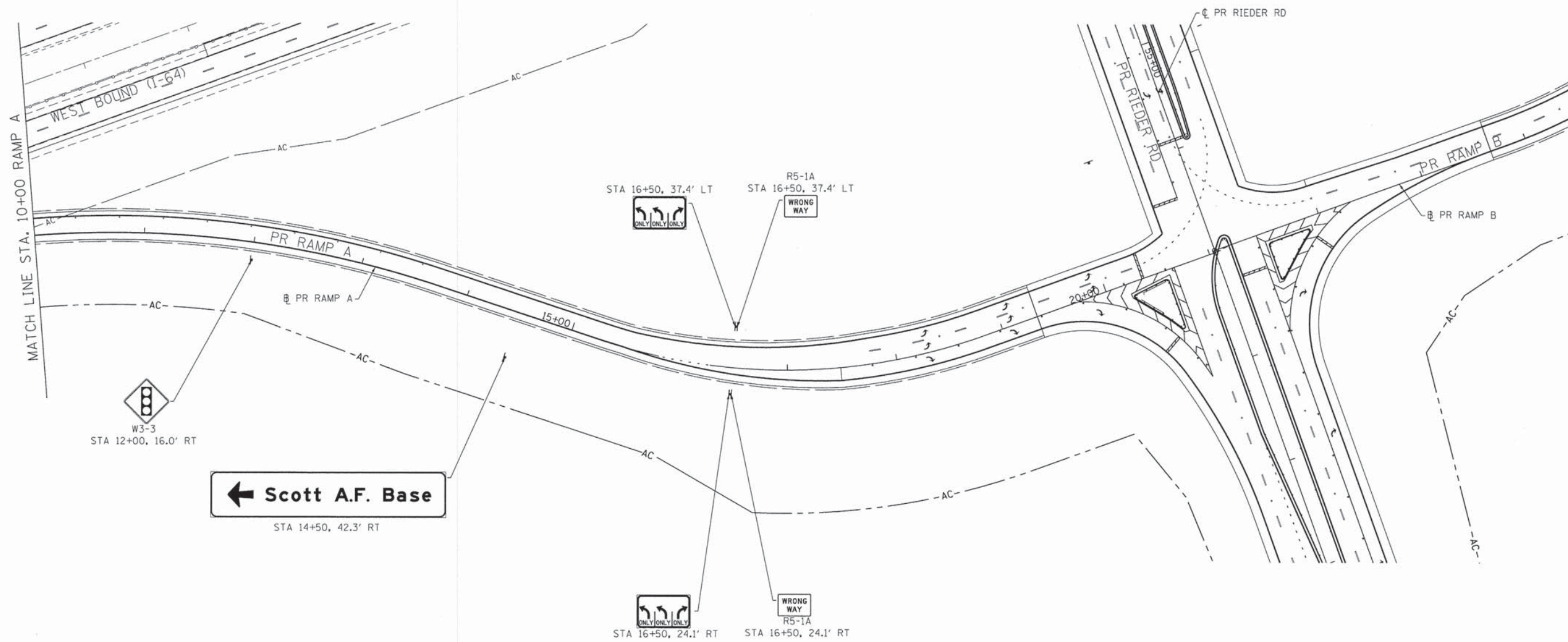
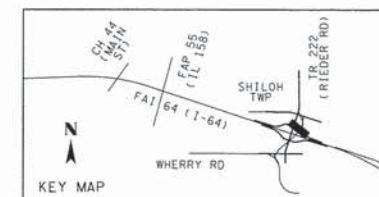

☒ EXISTING SIGN TO BE REMOVED  
 \* EXISTING SIGN TO REMAIN

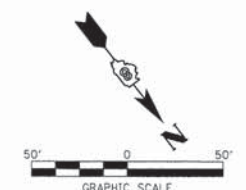

F:\09-0016\02 Rieder Road Phase II\118 CAD\CADD Sheets\09-0016-sht-1-64 Sign20.dgn

FILE NAME = 09-0016-sht-1-64 Sign20.dgn	USER NAME = IDOT	DESIGNED - SMS	REVISED - -
MODEL NAME = Default	DRAWN - SMS	CHECKED - LDC	REVISED - -
PLOT SCALE = 600.0000' / ft.	DATE - Apr 29, 2014		

**STATE OF ILLINOIS  
DEPARTMENT OF TRANSPORTATION**

**SIGNING PLAN  
PROPOSED RAMP A**

SCALE: 1" = 50'    SHEET NO. 21 OF 37 SHEETS    STA. 10+00 TO STA. 21+05.65

F.A.I. RTE.	SECTION	COUNTY	TOTAL SHEETS	SHEET NO.
64	09-00365-01-PV	ST. CLAIR	535	223
TR RTE. 222 (RIEDER ROAD)			CONTRACT NO. 97549	
ILLINOIS				

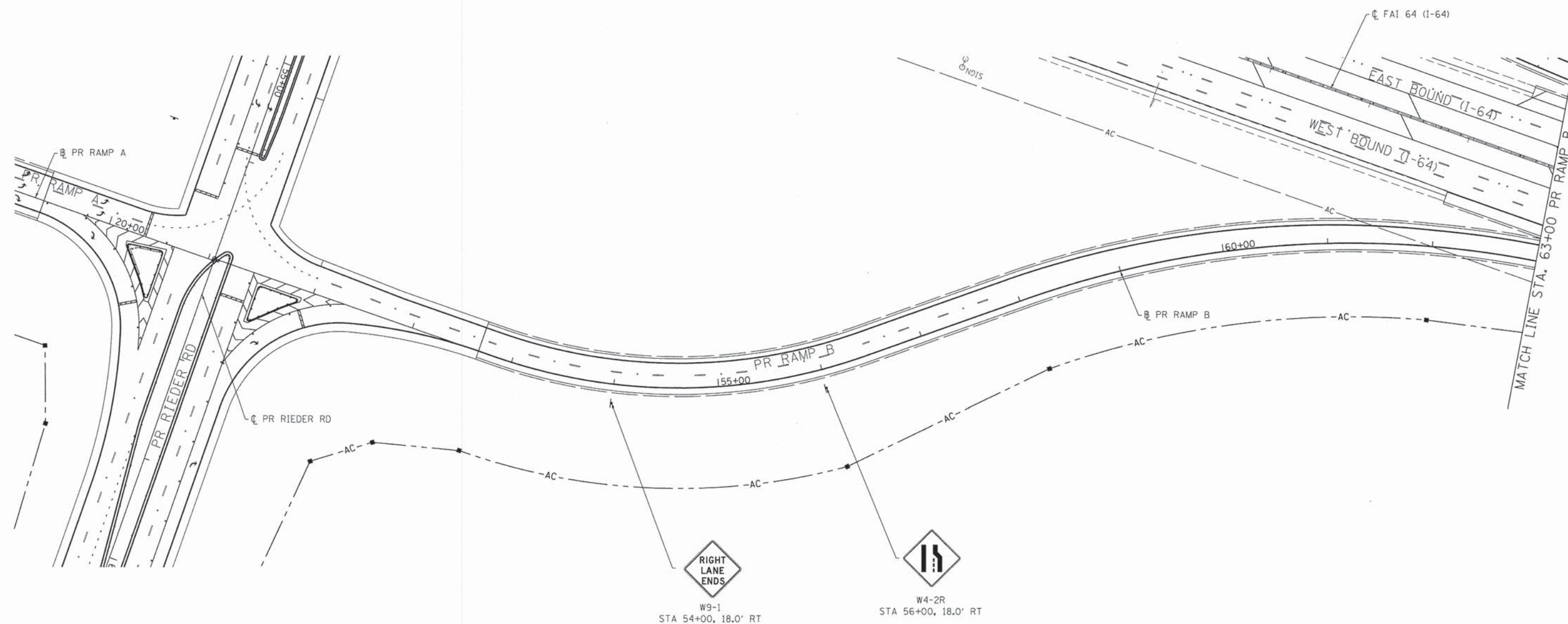
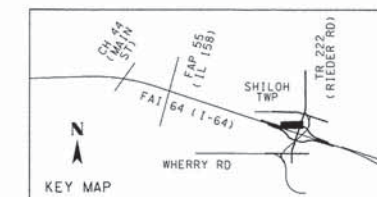

EXISTING SIGN TO BE REMOVED  
 EXISTING SIGN TO REMAIN

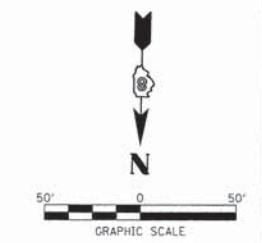

P:\09-0016\02\_Rieder\_Road\_Phase\_1\1\B\_CADD\CADD\_Sheets\09-0016-ah1-64\_Sign21.dgn

FILE NAME = 09-0016-ah1-64_Sign21.dgn	USER NAME = IDOT	DESIGNED - SMS	REVISED -
MODEL NAME = Default	DRAWN - SMS	REVISIONS -	REVISIONS -
PLDT SCALE = 600,0000 ' / ft.	CHECKED - LDC	REVISIONS -	REVISIONS -
PLDT DATE = 4/26/2014	DATE - April 29, 2014	REVISIONS -	REVISIONS -

**STATE OF ILLINOIS**  
**DEPARTMENT OF TRANSPORTATION**

**SIGNING PLAN**  
**PROPOSED RAMP B**

SCALE: 1" = 50'    SHEET NO. 22 OF 37 SHEETS    STA. 50+00    TO STA. 63+00

F.A.I. RTE.	SECTION	COUNTY	TOTAL SHEETS	SHEET NO.
64	09-00365-01-PV	ST. CLAIR	535	224
TR RTE. 222 (RIEDER ROAD)		CONTRACT NO. 97549		
ILLINOIS				



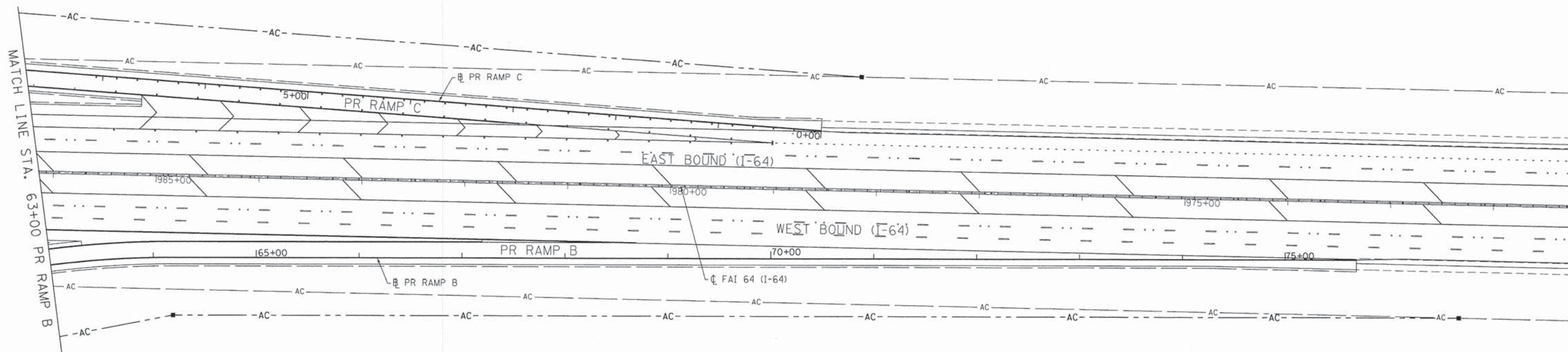
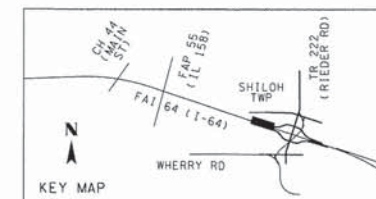

EXISTING SIGN TO BE REMOVED  
 EXISTING SIGN TO REMAIN

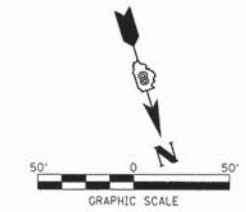

F:\09-0016\02 Render Road Phase 1\1\10 CAD\CAD00 Sheets\09-0016-sh1-1-64\_Sign22.dgn

FILE NAME = 09-0016-sh1-1-64_Sign22.dgn	USER NAME = IDOT	DESIGNED - SMS	REVISED -
	MODEL NAME = Default	DRAWN - SMS	REVISED -
	PLOT SCALE = 600.0000' / Ft.	CHECKED - LDC	REVISED -
	PLOT DATE = 4/26/2014	DATE - April 29, 2014	REVISED -

**STATE OF ILLINOIS**  
**DEPARTMENT OF TRANSPORTATION**

**SIGNING PLAN**  
**PROPOSED RAMP B**

SCALE: 1" = 50'    SHEET NO. 23 OF 37 SHEETS    STA. 63+00.00 TO STA. 75+69.19

F.A.I. RTE.	SECTION	COUNTY	TOTAL SHEETS	SHEET NO.
64	09-00365-01-PV	ST. CLAIR	535	225
TR RTE. 222 (RIEDER ROAD)		CONTRACT NO. 97549		
ILLINOIS				

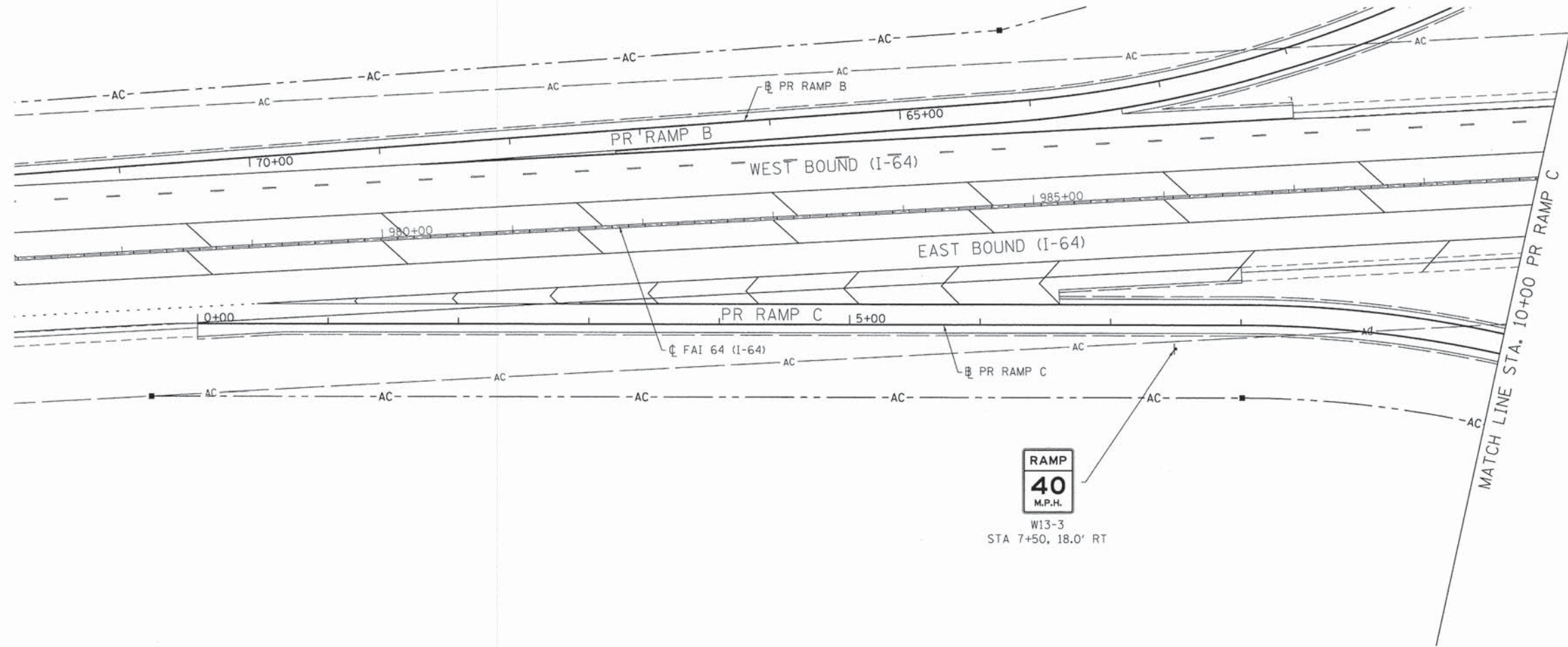
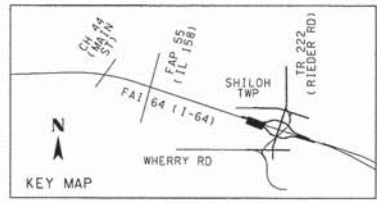

RAMP  
40  
M.P.H.  
W13-3  
STA 7+50, 18.0' RT

☒ EXISTING SIGN TO BE REMOVED  
\* EXISTING SIGN TO REMAIN

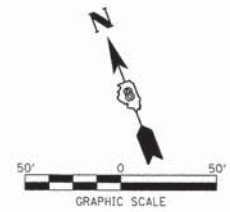

F:\09-0016\02\_Roadway\_Road Phase\_IL\B\_CADD\CADD\_Sheets\09-0016-sht-1-64\_Sign23.dgn

FILE NAME = 09-0016-sht-1-64_Sign23.dgn	USER NAME = IDOT	DESIGNED - SMS	REVISED - -
	MODEL NAME = Default	DRAWN - SMS	REVISED - -
	PLOT SCALE = 600.0000' / ft.	CHECKED - LDC	REVISED - -
	PLOT DATE = 4/26/2014	DATE - April 29, 2014	REVISED - -

**STATE OF ILLINOIS  
DEPARTMENT OF TRANSPORTATION**

**SIGNING PLAN  
PROPOSED RAMP C**

SCALE: 1" = 50'    SHEET NO. 24 OF 37 SHEETS    STA. 0+00    TO STA. 10+00

F.A.I. RTE.	SECTION	COUNTY	TOTAL SHEETS	SHEET NO.
64	09-00365-01-PV	ST. CLAIR	535	226
TR RTE. 222 (RIEDER ROAD)			CONTRACT NO. 97549	
ILLINOIS				

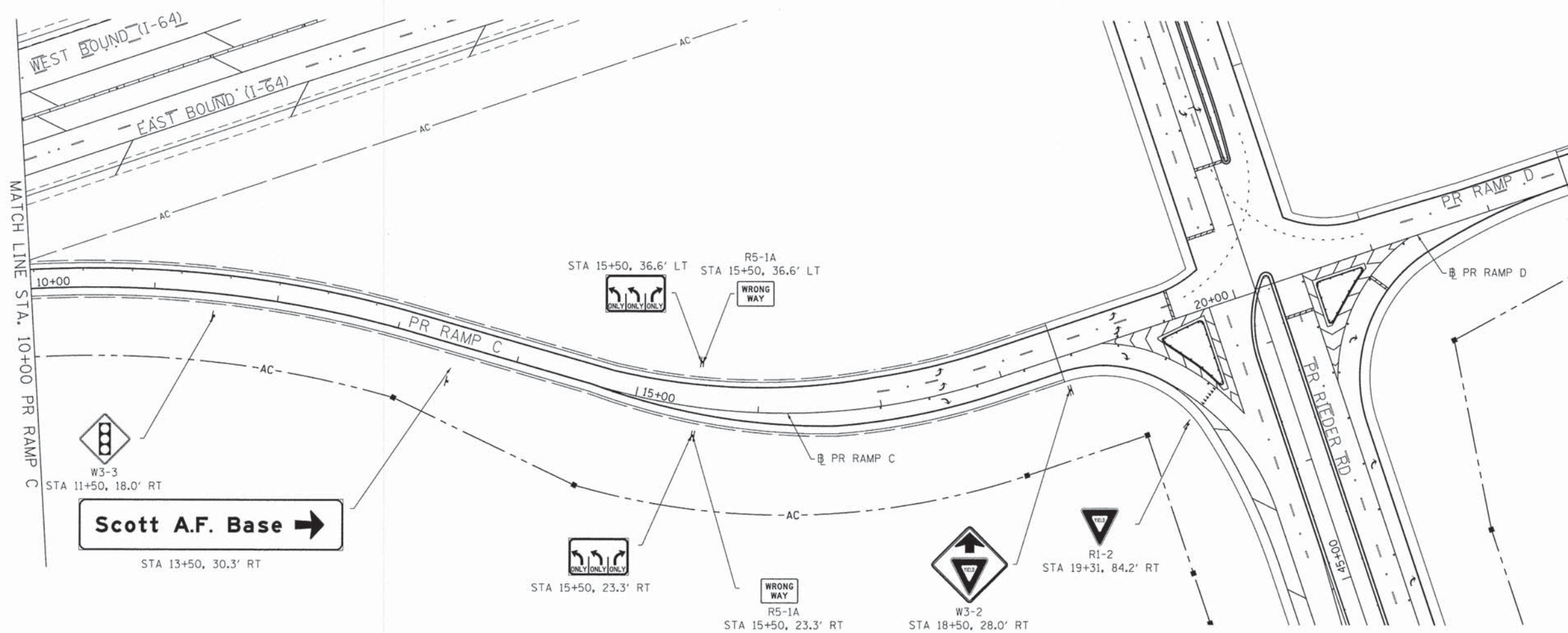
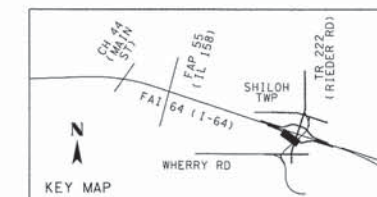

☒ EXISTING SIGN TO BE REMOVED  
 \* EXISTING SIGN TO REMAIN

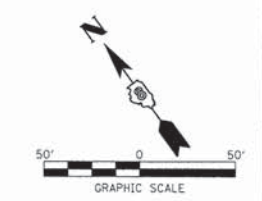

F:\09-0016\02 Rieder Road Phase I\1101\_CADD\CADD\_Sheets\09-0016-sht-1-64\_Sign24.dgn

FILE NAME = 09-0016-sht-1-64_Sign24.dgn	USER NAME = IDOT	DESIGNED - SMS	REVISED -
	MODEL NAME = Default	DRAWN - SMS	REVISED -
	PLOT SCALE = 600.0000' / Ft.	CHECKED - LDC	REVISED -
	PLOT DATE = 4/26/2014	DATE - April 29, 2014	REVISED -

**STATE OF ILLINOIS**  
**DEPARTMENT OF TRANSPORTATION**

**SIGNING PLAN**  
**PROPOSED RAMP C**

SCALE: 1" = 50'    SHEET NO. 25 OF 37 SHEETS    STA. 10+00    TO STA. 20+17.43

F.A.I. RTE.	SECTION	COUNTY	TOTAL SHEETS	SHEET NO.
64	09-00365-01-PV	ST. CLAIR	535	227
TR RTE. 222 (RIEDER ROAD)			CONTRACT NO. 97549	
ILLINOIS				

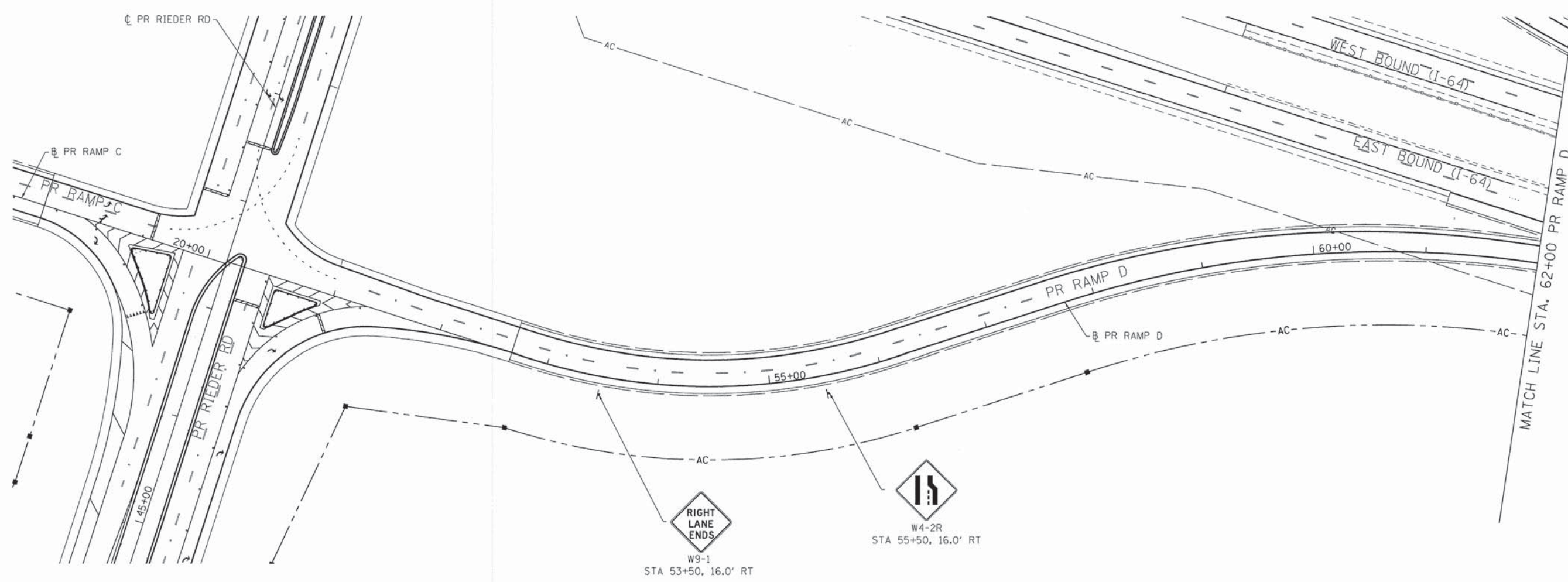
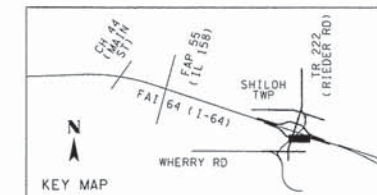

EXISTING SIGN TO BE REMOVED  
 EXISTING SIGN TO REMAIN

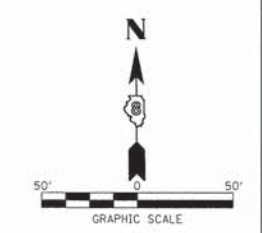

P:\09\_2016\02\_Rieder\_Road\_Phase\_1\119\_CAD\CADD\_Sheets\09\_2016\_sht-1-64\_Sign25.dgn

FILE NAME = 09-2016-sht-1-64_Sign25.dgn	USER NAME = IDOT	DESIGNED - SMS	REVISED -
	MODEL NAME = Default	DRAWN - SMS	REVISED -
	PLOT SCALE = 600.0000' / Ft.	CHECKED - LDC	REVISED -
	PLOT DATE = 4/26/2014	DATE - Apr'11 29, 2014	REVISED -

**STATE OF ILLINOIS**  
**DEPARTMENT OF TRANSPORTATION**

**SIGNING PLAN**  
**PROPOSED RAMP D**

SCALE: 1" = 50'    SHEET NO. 26 OF 37 SHEETS    STA. 50+00    TO STA. 62+00

F.A.I. RTE.	SECTION	COUNTY	TOTAL SHEETS	SHEET NO.
64	09-00365-01-PV	ST. CLAIR	535	228
TR RTE. 222 (RIEDER ROAD)			CONTRACT NO. 97549	
ILLINOIS				

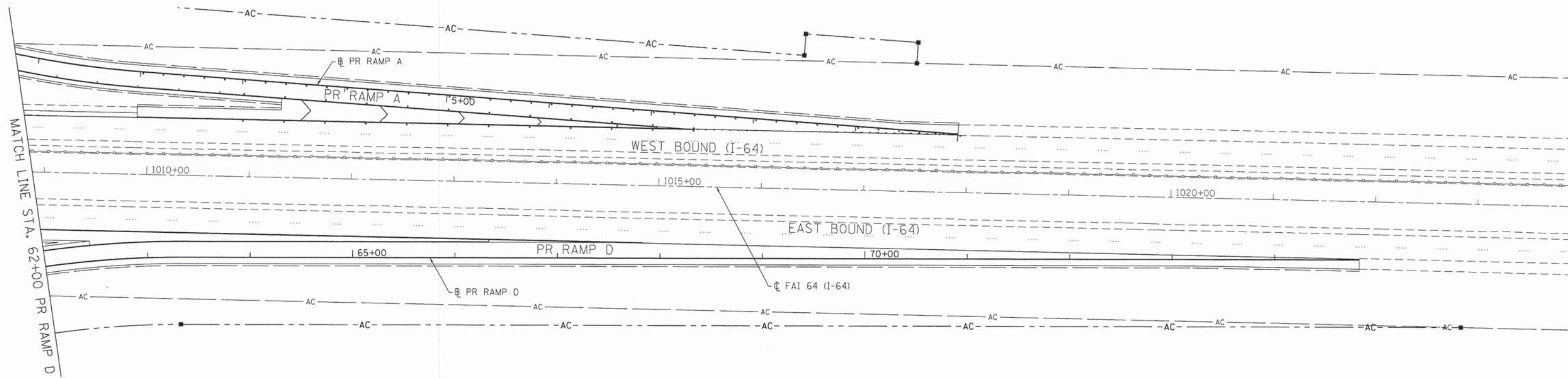
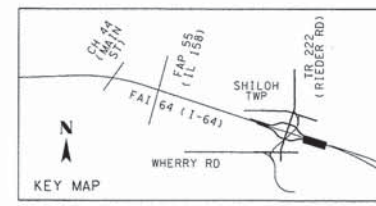

EXISTING SIGN TO BE REMOVED  
 EXISTING SIGN TO REMAIN

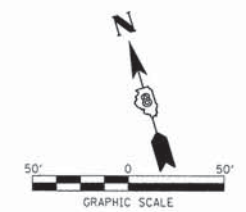

P:\g09-0016-01-01-0000\_Signing\09-0016-01-01-0000\_Signing\09-0016-01-01-0000\_Signing.dgn

FILE NAME = 09-0016-sht-1-64 Sign26.dgn	USER NAME = IDOT	DESIGNED - SMS	REVISED -
	MODEL NAME = Default	DRAWN - SMS	REVISED -
	PLOT SCALE = 600,0000' / ft.	CHECKED - LDC	REVISED -
	PLOT DATE = 4/26/2014	DATE - April 29, 2014	REVISED -

**STATE OF ILLINOIS**  
**DEPARTMENT OF TRANSPORTATION**

**SIGNING PLAN**  
**PROPOSED RAMP D**

SCALE: 1" = 50'    SHEET NO. 27 OF 37 SHEETS    STA. 62+00    TO STA. 74+82.59

F.A.I. RTE.	SECTION	COUNTY	TOTAL SHEETS	SHEET NO.
64	09-00365-01-PV	ST. CLAIR	535	229
TR RTE. 222 (RIEDER ROAD)		CONTRACT NO. 97549		
[ILLINOIS]				

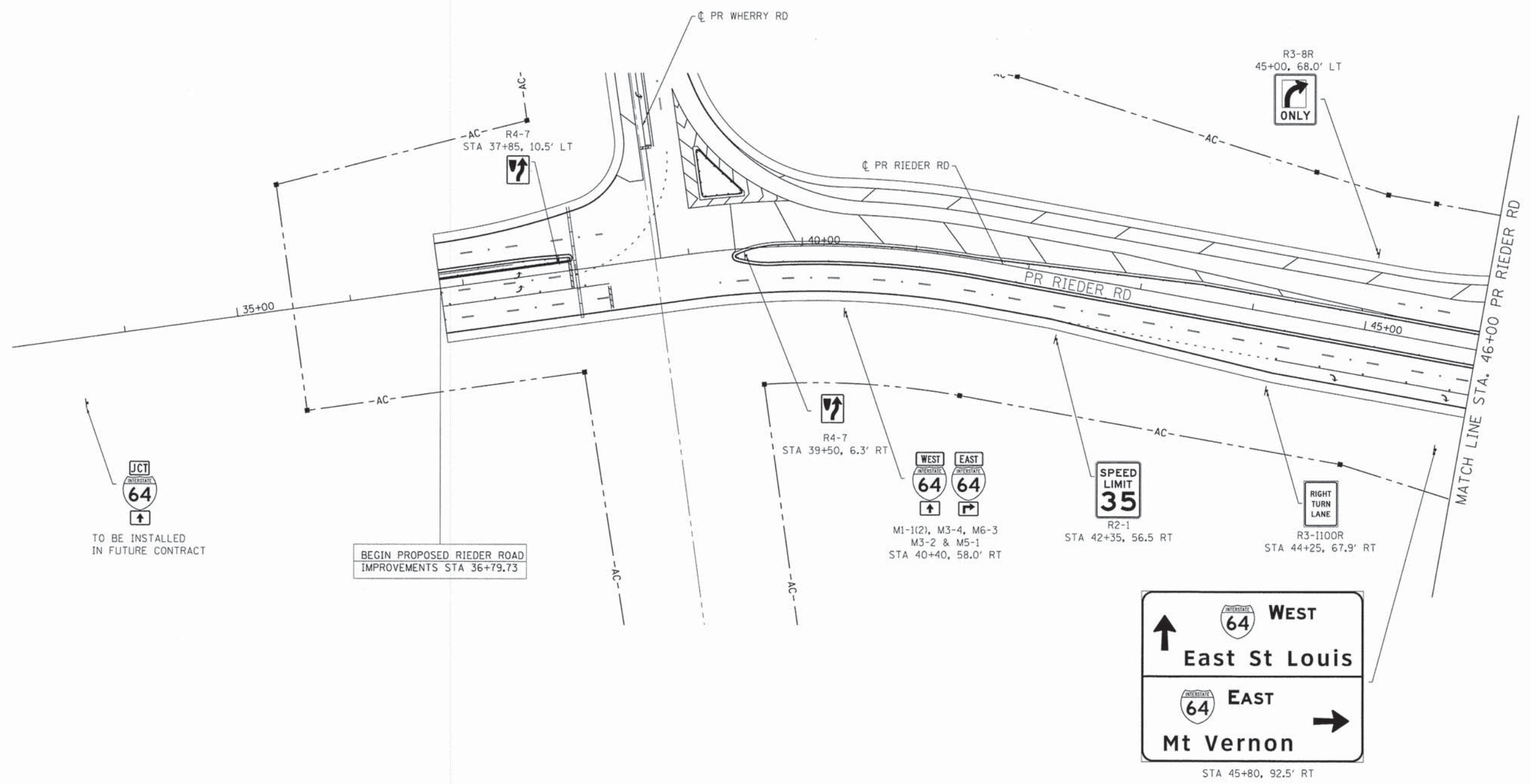
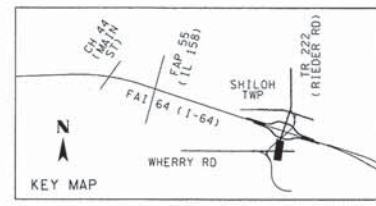

BEGIN PROPOSED RIEDER ROAD  
IMPROVEMENTS STA 36+79.73

WEST EAST  
64 64  
↑ ↓  
M1-1(2), M3-4, M6-3  
M3-2 & M5-1  
STA 40+40, 58.0' RT

SPEED  
LIMIT  
35  
R2-1  
STA 42+35, 56.5 RT

RIGHT  
TURN  
LANE  
R3-1100R  
STA 44+25, 67.9' RT

↑ WEST  
64 East St Louis  
64 EAST  
Mt Vernon →  
STA 45+80, 92.5' RT

⊗ EXISTING SIGN TO BE REMOVED  
\* EXISTING SIGN TO REMAIN

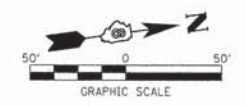

F:\09-0016\02 Rieder Road Phase II\118 CAD\CAD00 Sheets\09-0016-sht-1-64 Sign27.dgn

FILE NAME = 09-0016-sht-1-64 Sign27.dgn	USER NAME = I00T	DESIGNED - SMS	REVISED - -
	MODEL NAME = Default	DRAWN - SMS	REVISED - -
	PLOT SCALE = 600.0000' / ft.	CHECKED - LDC	REVISED - -
	PLOT DATE = 4/26/2014	DATE - Apr 11 29, 2014	REVISED - -

STATE OF ILLINOIS  
DEPARTMENT OF TRANSPORTATION

SIGNING PLAN  
PROPOSED RIEDER ROAD  
SCALE: 1" = 50'  
SHEET NO. 28 OF 37 SHEETS  
STA. 35+65.20 TO STA. 46+00

F.A.I. RTE.	SECTION	COUNTY	TOTAL SHEETS	SHEET NO.
64	09-00365-01-PV	ST. CLAIR	535	230
TR RTE. 222 (RIEDER ROAD)		CONTRACT NO. 97549		
ILLINOIS				

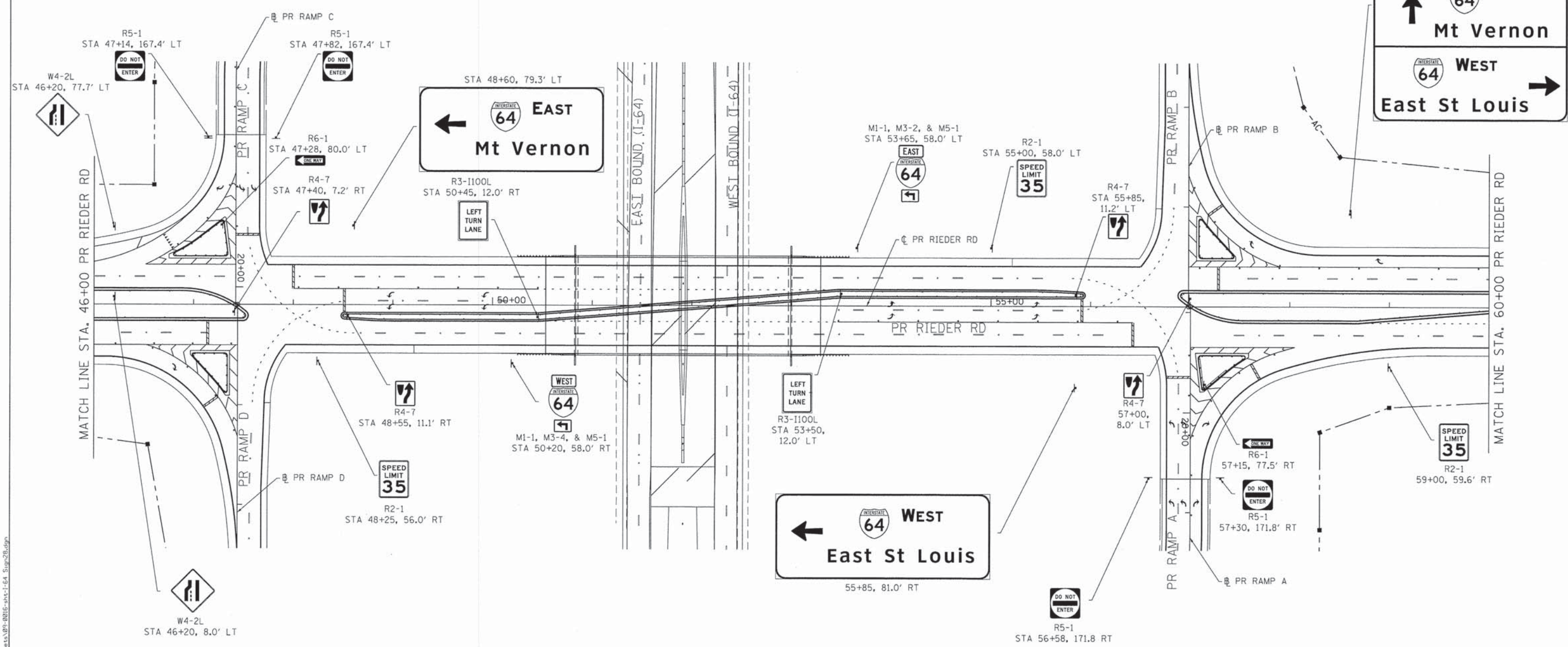
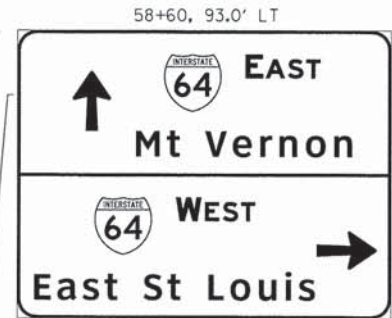
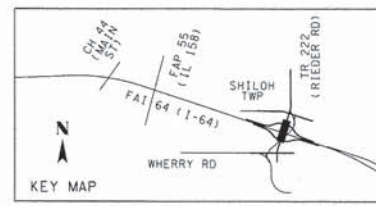

EXISTING SIGN TO BE REMOVED  
 EXISTING SIGN TO REMAIN

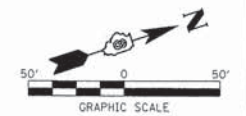

P:\09-0016\02 Rieder Road Phase 1\11B\_CADD\CADD Sheets\09-0016-sh1-1-64\_Sign28.dgn

FILE NAME = 09-0016-sh1-1-64_Sign28.dgn	USER NAME = IDOT	DESIGNED - SMS	REVISED -
MODEL NAME = Default	DRAWN - SMS	REVISED -	
PLOT SCALE = 600.0000' / ft.	CHECKED - LDC	REVISED -	
PLOT DATE = 4/26/2014	DATE - April 29, 2014	REVISED -	

**STATE OF ILLINOIS**  
**DEPARTMENT OF TRANSPORTATION**

**SIGNING PLAN**  
**PROPOSED RIEDER ROAD**  
 SCALE: 1" = 50'    SHEET NO. 29 OF 37 SHEETS    STA. 46+00 TO STA. 60+00

F.A.I. RTE.	SECTION	COUNTY	TOTAL SHEETS	SHEET NO.
64	09-00365-01-PV	ST. CLAIR	535	231
TR RTE. 222 (RIEDER ROAD)		CONTRACT NO. 97549		
ILLINOIS				

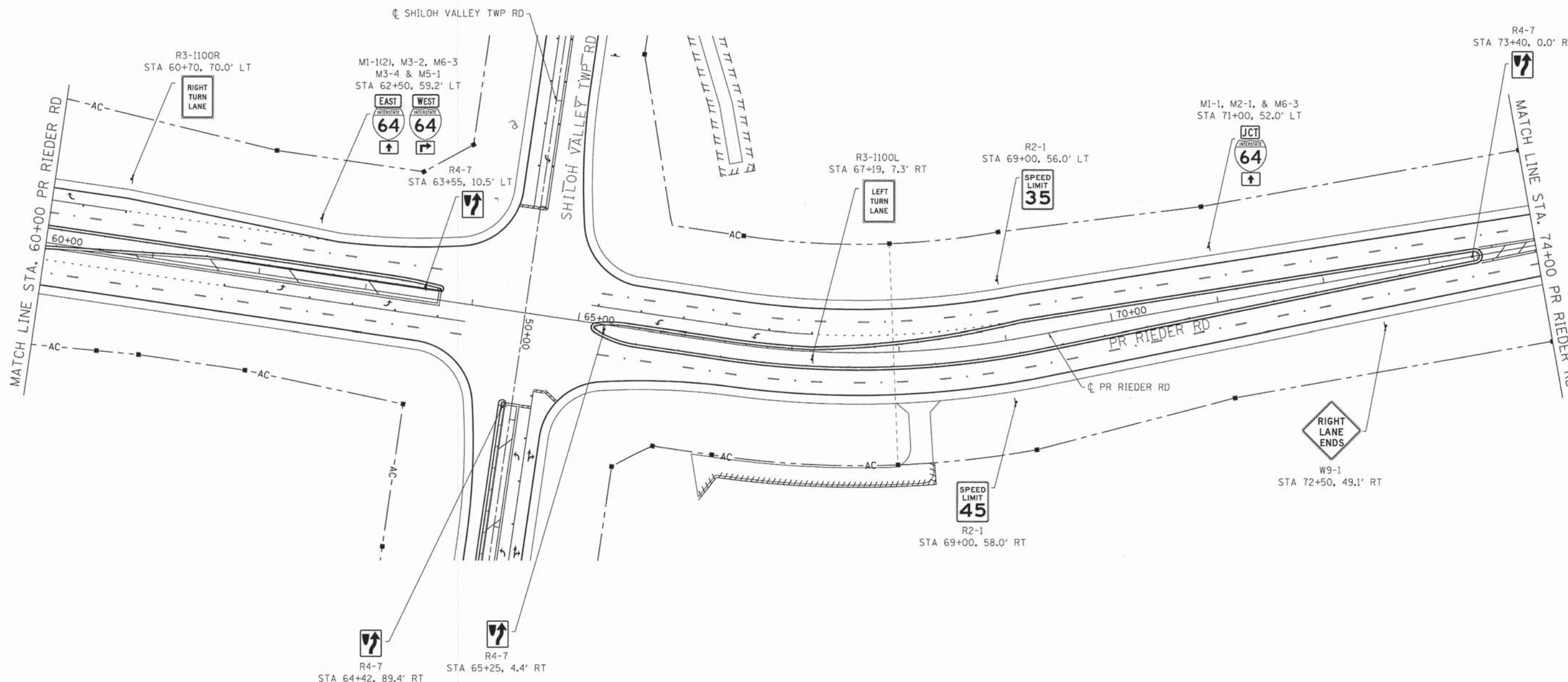
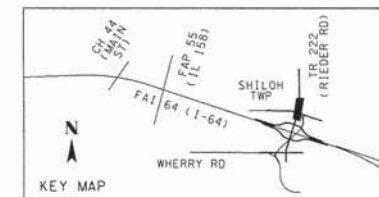

EXISTING SIGN TO BE REMOVED  
 EXISTING SIGN TO REMAIN



P:\09-2016\02 Rieder Road Phase 1\118 CAD\CADD Sheets\09-2016-sht-1-64 Sign29.dgn

FILE NAME = 09-2016-sht-1-64 Sign29.dgn	USER NAME = IDDT	DESIGNED - SMS	REVISED - -
MODEL NAME = Default	DRAWN - SMS	CHECKED - LDC	REVISED - -
PLOT SCALE = 600.0000' / Ft.	DATE - April 29, 2014		REVISED - -

**STATE OF ILLINOIS**  
**DEPARTMENT OF TRANSPORTATION**

**SIGNING PLAN**  
**PROPOSED RIEDER ROAD**

SCALE: 1" = 50'    SHEET NO. 30 OF 37 SHEETS    STA. 60+00    TO STA. 74+00

F.A.I. RTE.	SECTION	COUNTY	TOTAL SHEETS	SHEET NO.
64	09-00365-01-PV	ST. CLAIR	535	232
TR RTE. 222 (RIEDER ROAD)			CONTRACT NO. 97549	
[ILLINOIS]				



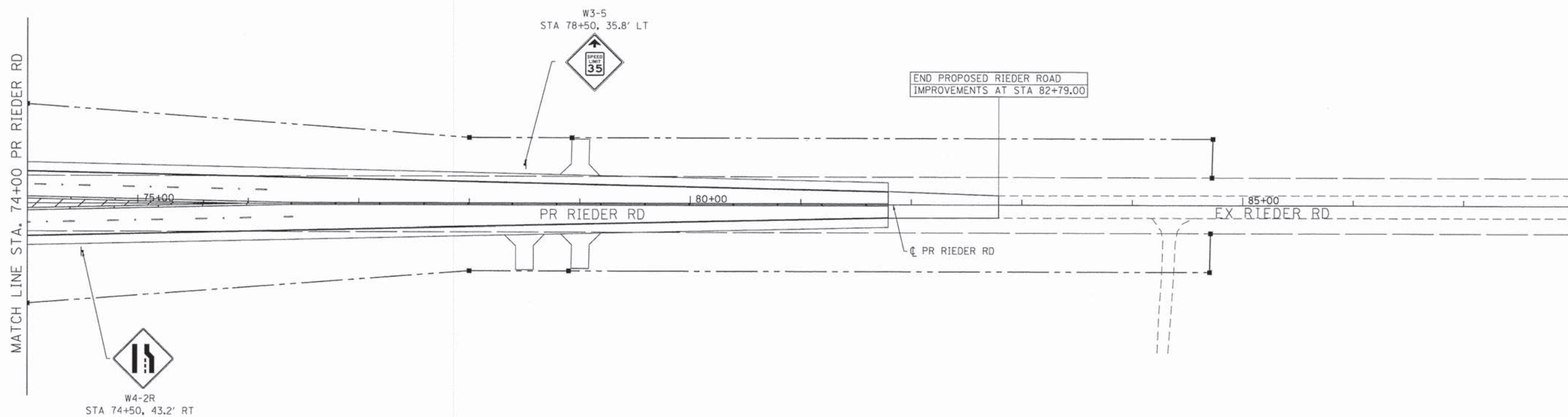
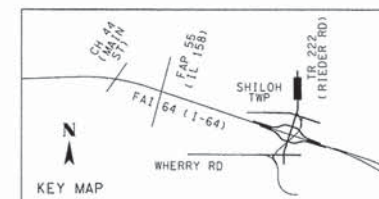

EXISTING SIGN TO BE REMOVED  
 EXISTING SIGN TO REMAIN

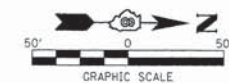

P:\09-0016-02 Rieder Road Phase 1\1\B CAD\CADD Sheets\09-0016-0216-01-64 Sign30.dgn

FILE NAME =  
 09-0016-01-64 Sign30.dgn

USER NAME =	IDOT	DESIGNED -	SMS	REVISED -	
MODEL NAME =	Default	DRAWN -	SMS	REVISED -	
PLOT SCALE =	600.0000' / Ft.	CHECKED -	LDC	REVISED -	
PLOT DATE =	4/26/2014	DATE -	April 29, 2014	REVISED -	

**STATE OF ILLINOIS  
 DEPARTMENT OF TRANSPORTATION**

**SIGNING PLAN  
 PROPOSED RIEDER ROAD**

SCALE: 1" = 50'    SHEET NO. 31 OF 37 SHEETS    STA. 74+00    TO STA. 82+79.00

F.A.I. RTE.	SECTION	COUNTY	TOTAL SHEETS	SHEET NO.
64	09-00365-01-PV	ST. CLAIR	535	233
TR RTE. 222 (RIEDER ROAD)		CONTRACT NO. 97549		
ILLINOIS				

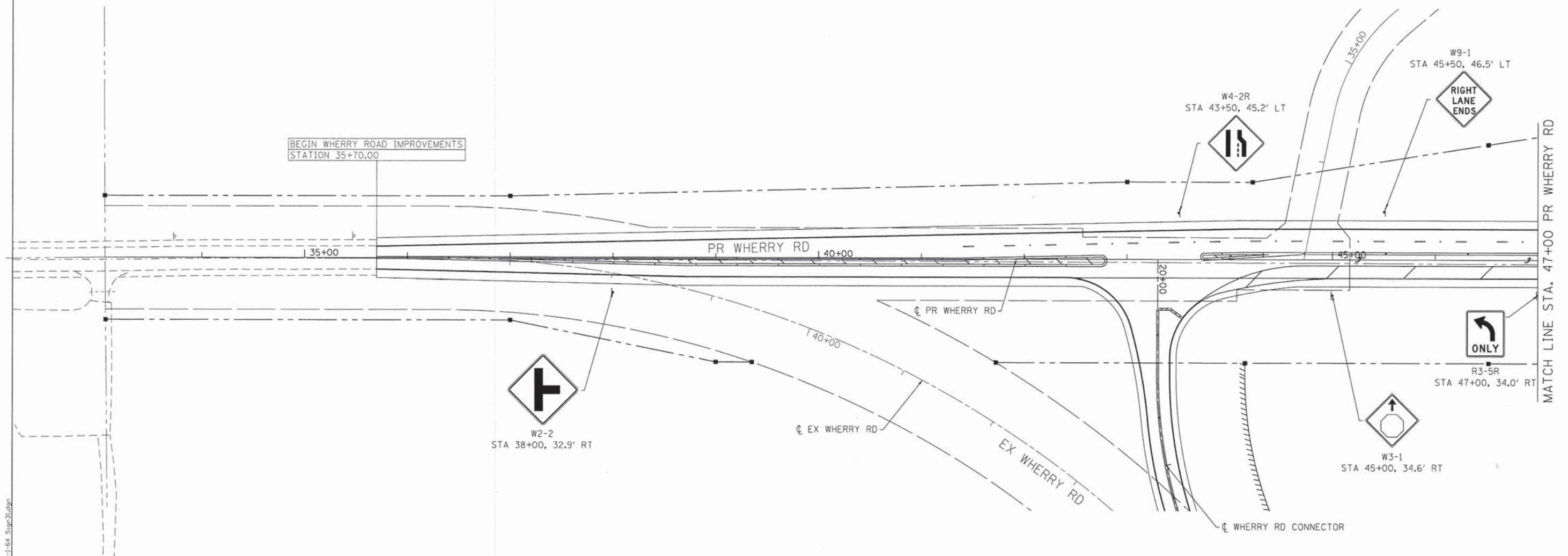
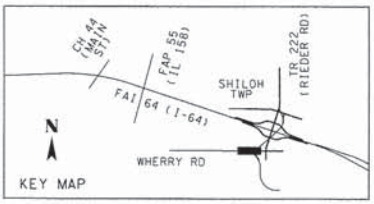

EXISTING SIGN TO BE REMOVED  
 EXISTING SIGN TO REMAIN

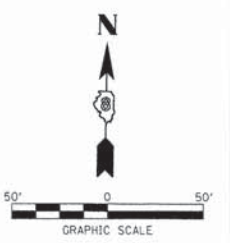

P:\09-0016-02 Rieder Road Phase 1\1108.LCDD\CADD Sheets\09-0016-sht-1-64\_Sign31.dgn

FILE NAME = 09-0016-sht-1-64_Sign31.dgn	USER NAME = IDOT	DESIGNED - SMS	REVISED - -
	MODEL NAME = Default	DRAWN - SMS	REVISED - -
	PLOT SCALE = 600.0000' / ft.	CHECKED - LDC	REVISED - -
	PLOT DATE = 4/26/2014	DATE - April 29, 2014	REVISED - -

**STATE OF ILLINOIS**  
**DEPARTMENT OF TRANSPORTATION**

**SIGNING PLAN**  
**PROPOSED WHERRY ROAD**

SCALE: 1" = 50'    SHEET NO. 32 OF 37 SHEETS    STA. 35+70.00 TO STA. 47+00

F.A.I. RTE.	SECTION	COUNTY	TOTAL SHEETS	SHEET NO.
64	09-00365-01-PV	ST. CLAIR	535	234
TR RTE. 222 (RIEDER ROAD)			CONTRACT NO. 97549	
ILLINOIS				

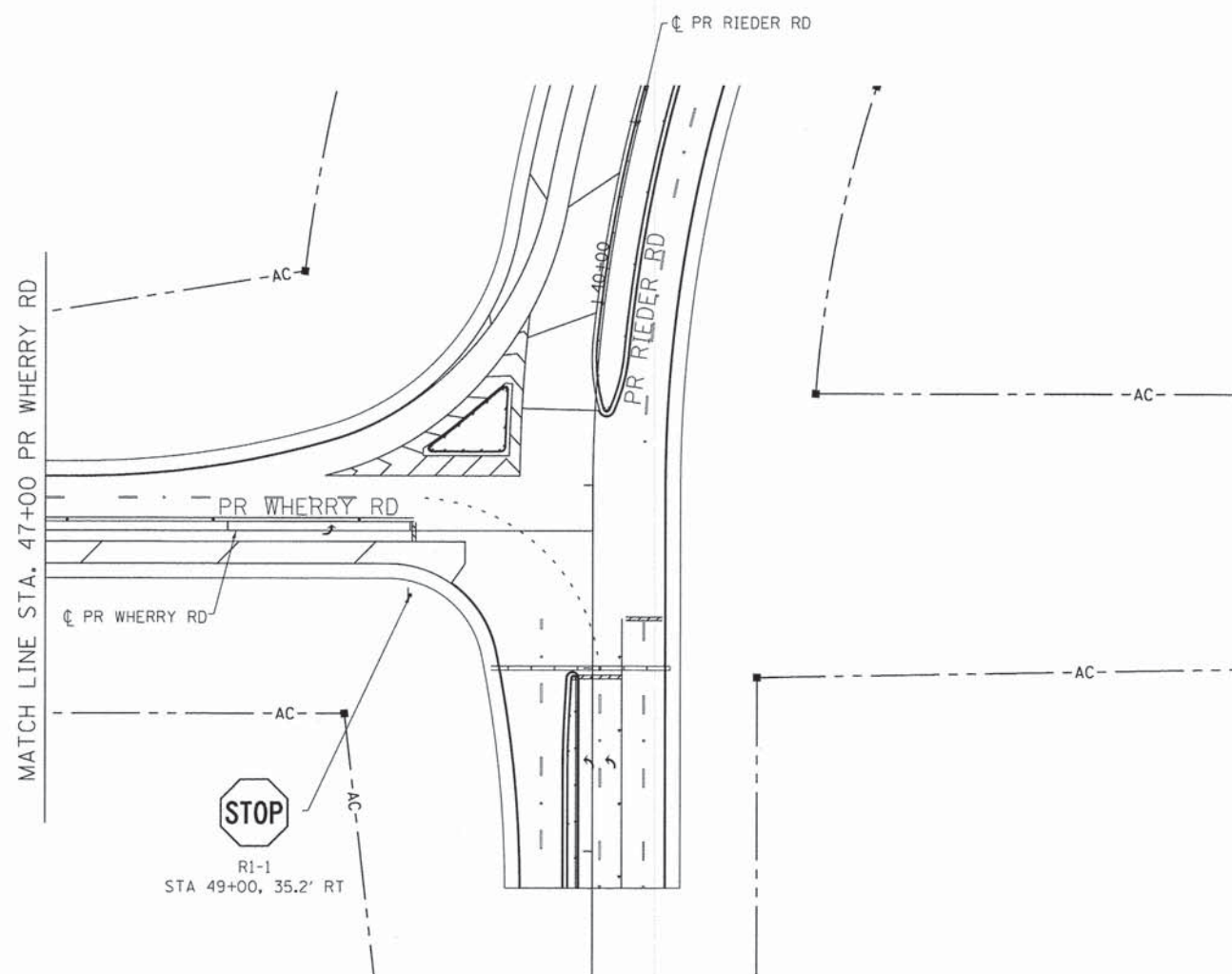
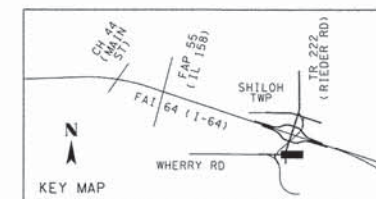

R1-1  
STA 49+00, 35.2' RT

- ☒ EXISTING SIGN TO BE REMOVED
- \* EXISTING SIGN TO REMAIN

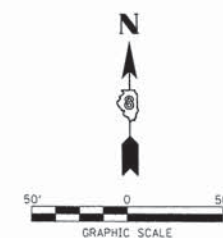

F:\09-0016\02 Rieder Road Phase II\100\CAD\CAD00\_Sheet\09-0016-sh1-1-64\_Sign32.dgn

FILE NAME =  
09-0016-sh1-1-64\_Sign32.dgn

USER NAME =	IDOT	DESIGNED -	SMS	REVISED -	
MODEL NAME =	Default	DRAWN -	SMS	REVISED -	
PLOT SCALE =	600.0000' / ft.	CHECKED -	LDC	REVISED -	
PLOT DATE =	4/26/2014	DATE -	Apr 29, 2014	REVISED -	

**STATE OF ILLINOIS  
DEPARTMENT OF TRANSPORTATION**

**SIGNING PLAN  
PROPOSED WHERRY ROAD**

SCALE: 1" = 50'    SHEET NO. 33 OF 37 SHEETS    STA. 47+00    TO STA. 52+17.37

F.A.I. RTE.	SECTION	COUNTY	TOTAL SHEETS	SHEET NO.
64	09-00365-01-PV	ST. CLAIR	535	235
TR RTE. 222 (RIEDER ROAD)			CONTRACT NO. 97549	
ILLINOIS				

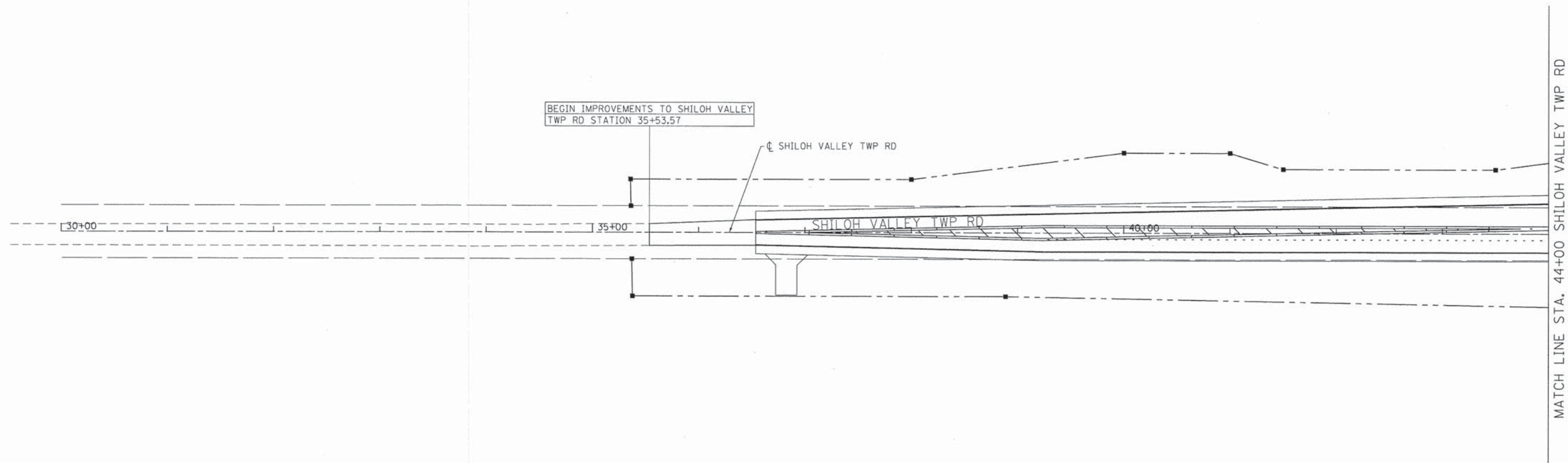
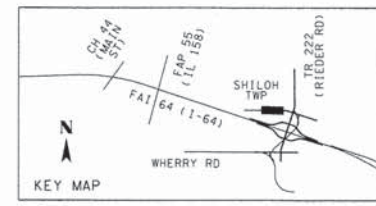

EXISTING SIGN TO BE REMOVED  
 EXISTING SIGN TO REMAIN

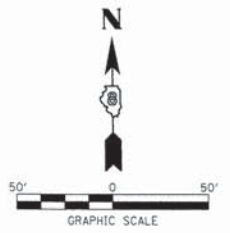

P:\09-0016\02 Rieder Road Phase II\1108.CAD\CAD00 Sheets\09-0016-sht-1-64 Sign33.dgn

FILE NAME = 09-0016-sht-1-64 Sign33.dgn	USER NAME = IDOT	DESIGNED - SMS	REVISED -
	MODEL NAME = Default	DRAWN - SMS	REVISED -
	PLOT SCALE = 600.0000' / ft.	CHECKED - LDC	REVISED -
	PLOT DATE = 4/26/2014	DATE - April 29, 2014	REVISED -

**STATE OF ILLINOIS**  
**DEPARTMENT OF TRANSPORTATION**

**SIGNING PLAN**  
**SHILOH VALLEY TOWNSHIP ROAD**  
 SCALE: 1" = 50'    SHEET NO. 34 OF 37 SHEETS    STA. 35+53.57    TO STA. 44+00

F.A.I. RTE.	SECTION	COUNTY	TOTAL SHEETS	SHEET NO.
64	09-00365-01-PV	ST. CLAIR	535	236
TR RTE. 222 (RIEDER ROAD)		CONTRACT NO. 97549		
[ILLINOIS]				

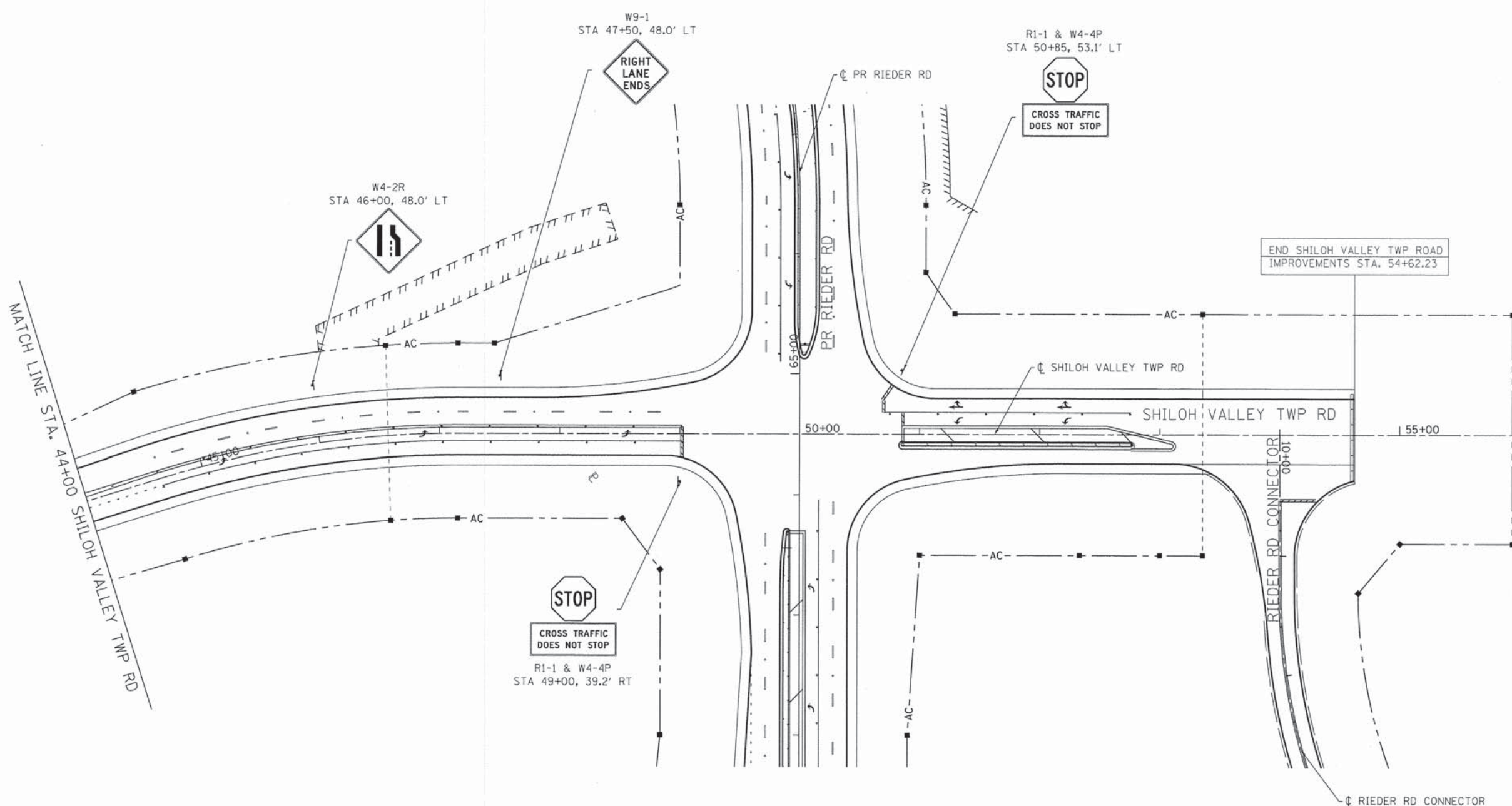
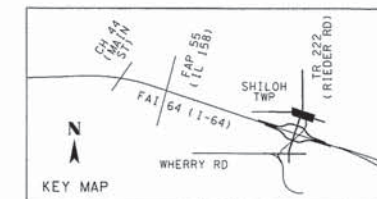

EXISTING SIGN TO BE REMOVED  
 EXISTING SIGN TO REMAIN

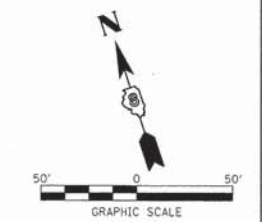

P:\01-0016\02 Rieder Road Phase II\B\CADD\000 Sheets\01-0016-sh1-1-64\_Sign34.dgn

FILE NAME = 01-0016-sh1-1-64\_Sign34.dgn  
 USER NAME = IDOT  
 MODEL NAME = Default  
 PLOT SCALE = 600.0000' / ft.  
 PLOT DATE = 4/26/2014

DESIGNED - SMS	REVISED -
DRAWN - SMS	REVISED -
CHECKED - LDC	REVISED -
DATE - April 29, 2014	REVISED -



**STATE OF ILLINOIS  
 DEPARTMENT OF TRANSPORTATION**

**SIGNING PLAN  
 SHILOH VALLEY TOWNSHIP ROAD**  
 SCALE: 1" = 50'    SHEET NO. 35 OF 37 SHEETS    STA. 44+00 TO STA. 55+84.00

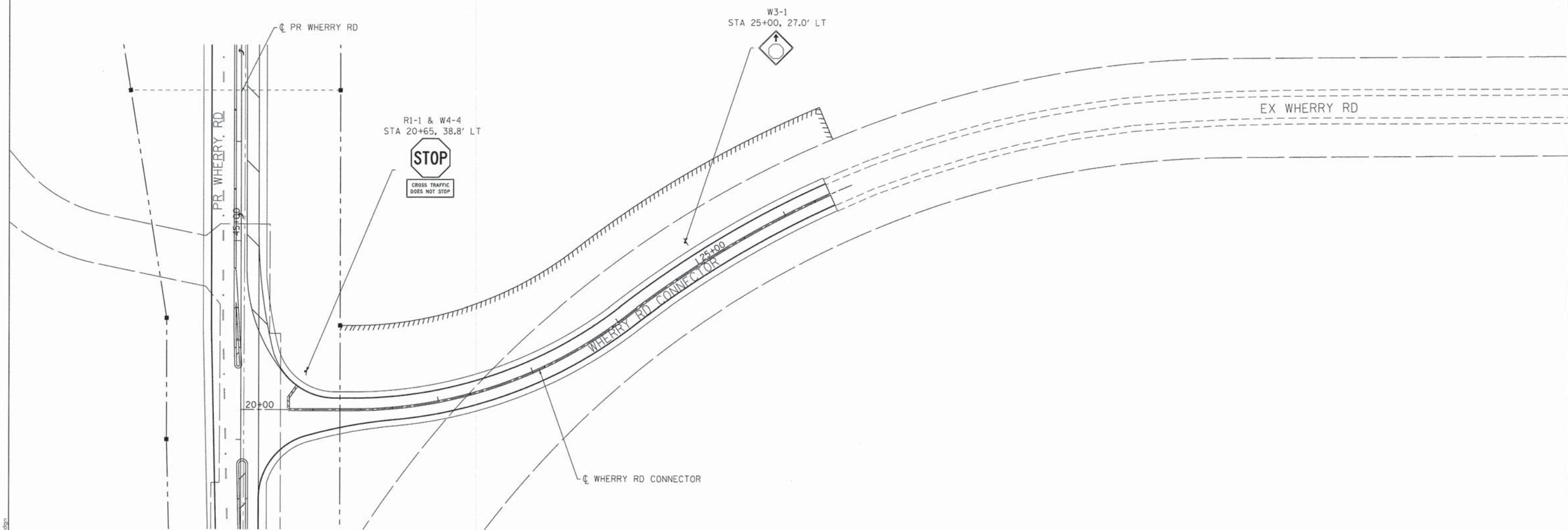
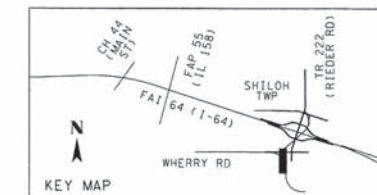
F.A.I. RTE.	SECTION	COUNTY	TOTAL SHEETS	SHEET NO.
64	09-00365-01-PV	ST. CLAIR	535	237
TR RTE. 222 (RIEDER ROAD)		CONTRACT NO. 97549		
ILLINOIS				



P:\09-0016\02 Rieder Road Phase 1\118 CAD\CADD Sheets\09-0016-sht-1-64 Sign35.dgn

 EXISTING SIGN TO BE REMOVED  
 EXISTING SIGN TO REMAIN

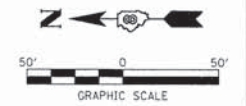

FILE NAME = 09-0016-sht-1-64 Sign35.dgn	USER NAME = 100T	DESIGNED - SMS	REVISED -
MODEL NAME = Default	DRAWN - SMS	CHECKED - LDC	REVISED -
PLOT SCALE = 50.0000' / in.	DATE - Apr 29, 2014		

**STATE OF ILLINOIS  
DEPARTMENT OF TRANSPORTATION**

**SIGNING PLAN  
WHERRY ROAD CONNECTOR**

SCALE: 1" = 50'    SHEET NO. 36 OF 37 SHEETS    STA. 20+00    TO STA. 26+50

F.A.I. RTE.	SECTION	COUNTY	TOTAL SHEETS	SHEET NO.
64	09-00365-01-PV	ST. CLAIR	535	238
TR RTE. 222 (RIEDER ROAD)		CONTRACT NO. 97549		
ILLINOIS				

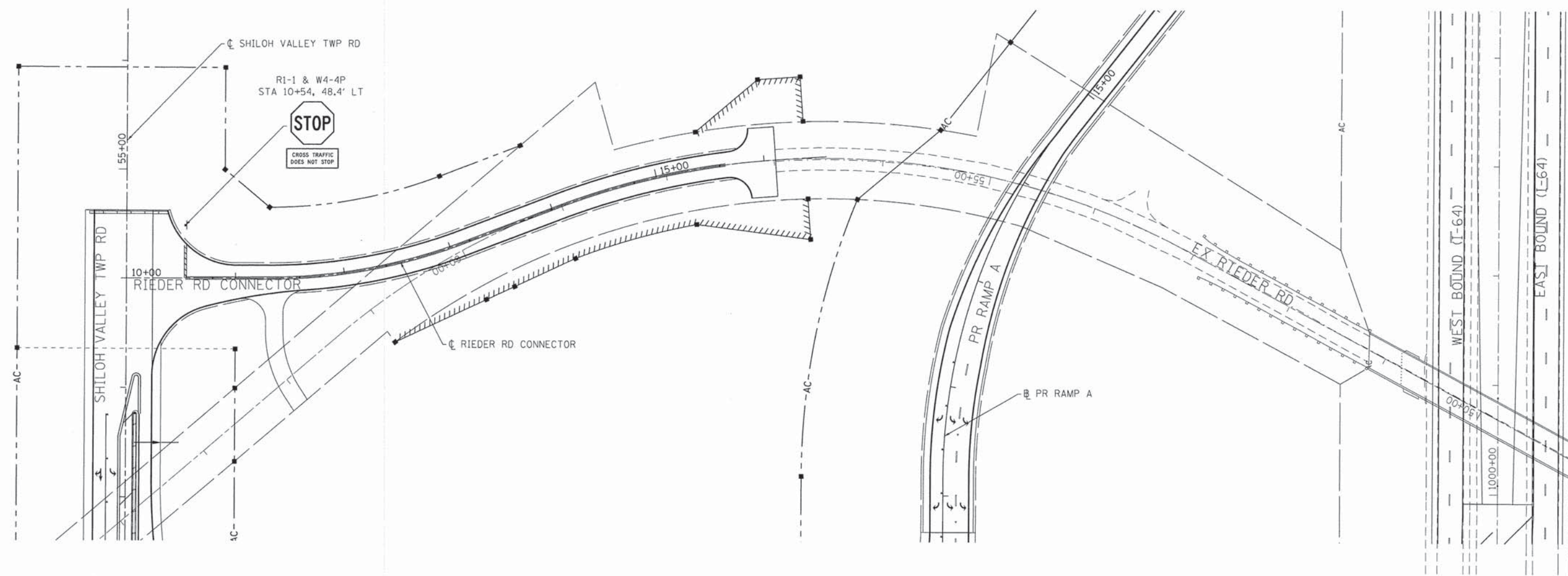

- ☒ EXISTING SIGN TO BE REMOVED
- \* EXISTING SIGN TO REMAIN

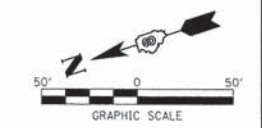

P:\09-0016-02 Rieder Road Phase 1\10 CAD\CADD Sheets\09-0016-sht-1-64 Sign36.dgn

FILE NAME = 09-0016-sht-1-64 Sign36.dgn	USER NAME = IDOT	DESIGNED - SMS	REVISED -
MODEL NAME = Default	DRAWN - SMS	REVISIONS	REVISED -
PLOT SCALE = 50.0000' / in.	CHECKED - LDC	REVISIONS	REVISED -
PLOT DATE = 4/26/2014	DATE - April 29, 2014	REVISIONS	REVISED -

**STATE OF ILLINOIS**  
**DEPARTMENT OF TRANSPORTATION**

SIGNING PLAN	
RIEDER ROAD CONNECTOR	
SCALE: 1" = 50'	SHEET NO. 37 OF 37 SHEETS
STA. 10+00	TO STA. 16+10.57

F.A.I. RTE.	SECTION	COUNTY	TOTAL SHEETS	SHEET NO.
64	09-00365-01-PV	ST. CLAIR	535	239
TR RTE. 222 (RIEDER ROAD)		CONTRACT NO. 97549		
ILLINOIS				







SIGN DETAIL

1:75

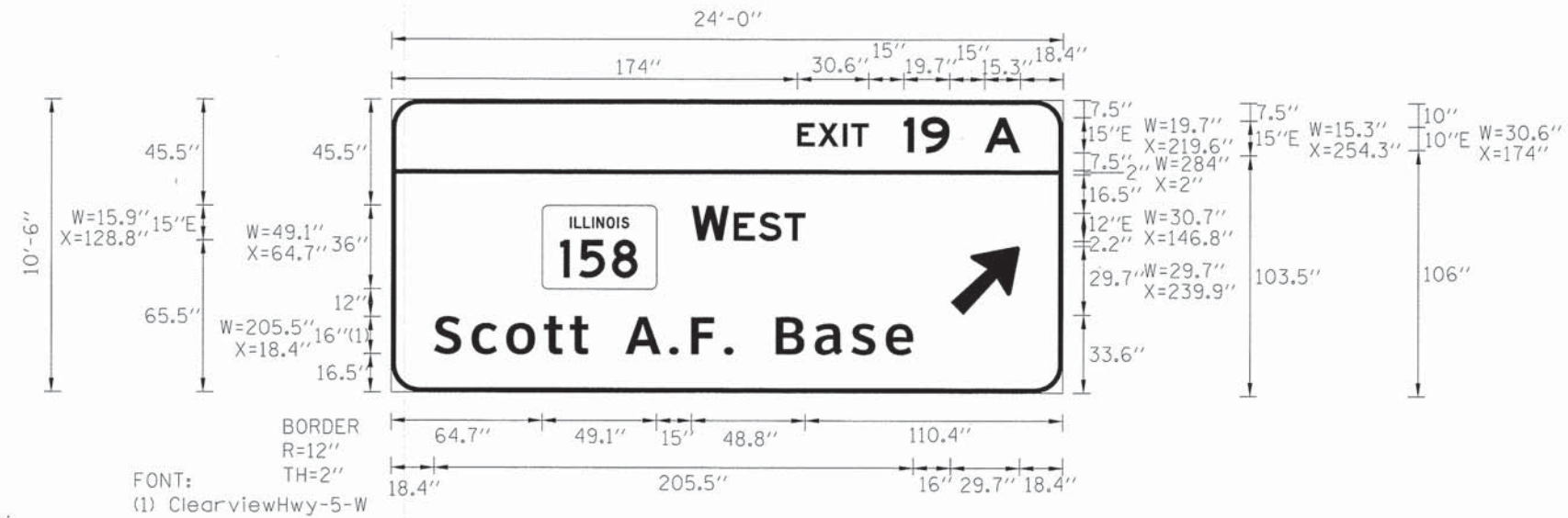

Panel Style: guide\_fwy\_overhead\_clear\_exit.ssi  
 Dimensions are in inches.tenths

Letter locations are panel edge to lower left corner

SIGN NUMBER	STR NO 8S0821064R018.4
WIDTH x HGHT.	24'-0" x 10'-6"
BORDER WIDTH	2"
CORNER RADIUS	12"
MOUNTING	Overhead
BACKGROUND	TYPE: Reflective
	COLOR: Green
LEGENDBORDER	TYPE: Reflective
	COLOR: WhiteWhite

SYMBOL	ROT	X	Y	WID	HT
M1-1100A-3-22-10D	100	64.7	44.5	49.1	36
AR_Type A	315	239.9	33.6	24	37.7

LETTER POSITIONS (X)

LETTER	X	Y	WID	HT	LENGTH	SERIES/SIZE
E	174	44.5	49.1	36	95.6	E 2000
X	182.9	44.5	49.1	36	95.6	10,15
I	193.6	44.5	49.1	36	95.6	10,15
T	197.1	44.5	49.1	36	95.6	10,15
1	219.6	44.5	49.1	36	95.6	10,15
9	227.1	44.5	49.1	36	95.6	10,15
A	254.3	44.5	49.1	36	95.6	10,15
W	128.8	103.5	48.8	15.12	48.8	E 2000
E	146.8	103.5	48.8	15.12	48.8	15,12
S	157.5	103.5	48.8	15.12	48.8	15,12
T	168.6	103.5	48.8	15.12	48.8	15,12
S	18.4	106	205.5	16.13	205.5	ClearviewHwy-5-W
c	34.5	106	205.5	16.13	205.5	1613
o	49.4	106	205.5	16.13	205.5	1613
t	65.6	106	205.5	16.13	205.5	1613
t	76.6	106	205.5	16.13	205.5	1613
A	100.5	106	205.5	16.13	205.5	1613
.	119.2	106	205.5	16.13	205.5	1613
F	128.7	106	205.5	16.13	205.5	1613
.	142.8	106	205.5	16.13	205.5	1613
B	146.8	106	205.5	16.13	205.5	1613
a	165	106	205.5	16.13	205.5	1613
s	181.7	106	205.5	16.13	205.5	1613
e	197.4	106	205.5	16.13	205.5	1613
.	212.1	106	205.5	16.13	205.5	1613

P:\09-0016\02 Rieder Road Phase II\10\_CAD\CADD Sheets\09-0016-shr-signpanel19.dgn





SIGN DETAIL

1:75

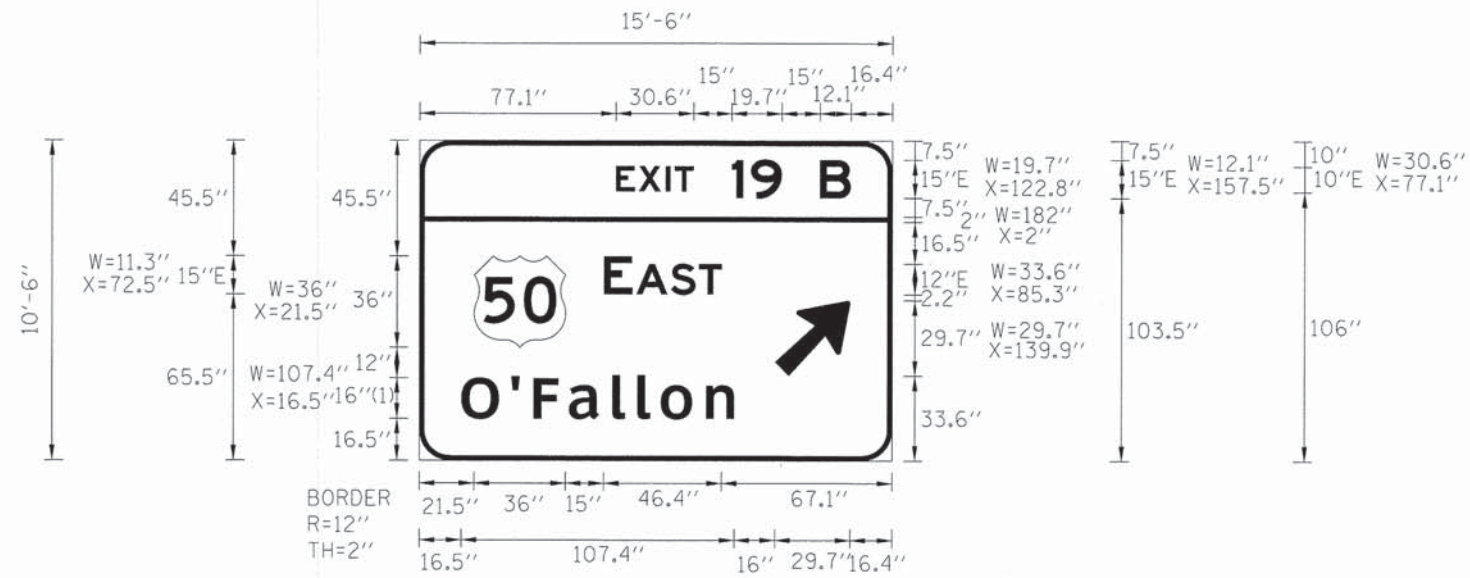

Panel Style: guide\_fwy\_overhead\_clear\_exit.ssi  
 Dimensions are in inches.tenths

FONT:  
 (1) ClearviewHwy-5-W

Letter locations are panel edge to lower left corner

SIGN NUMBER	STR NO 8S0821064L019.1
WIDTH x HGHT.	15'-6" x 10'-6"
BORDER WIDTH	2"
CORNER RADIUS	12"
MOUNTING	Overhead
BACKGROUND	TYPE: Reflective
	COLOR: Green
LEGEND/BORDER	TYPE: Reflective
	COLOR: White/White

SYMBOL	ROT	X	Y	WID	HT
M1_4	0	21.5	44.5	36	36
AR_Type A	315	139.9	33.6	24	37.7

LETTER POSITIONS (X)

LETTER	X	Y	W	H	LENGTH	SERIESSIZE
E	77.1	45.5	11.3	15	92.5	E 2000
X	86.1	45.5	11.3	15	92.5	10,15
I	96.8	45.5	11.3	15	92.5	10,15
T	100.3	45.5	11.3	15	92.5	10,15
1	122.8	45.5	11.3	15	92.5	10,15
9	130.3	45.5	11.3	15	92.5	10,15
B	157.5	45.5	11.3	15	92.5	10,15
E	72.5	65.5	11.3	15	46.4	E 2000
A	85.3	65.5	11.3	15	46.4	15,12
S	98.9	65.5	11.3	15	46.4	15,12
T	109.9	65.5	11.3	15	46.4	15,12
O	16.5	106	107.4	16	107.4	ClearviewHwy-5-W
'	36.2	106	107.4	16	107.4	1613
F	44.9	106	107.4	16	107.4	1613
a	58.9	106	107.4	16	107.4	1613
l	75.9	106	107.4	16	107.4	1613
l	85.8	106	107.4	16	107.4	1613
o	95	106	107.4	16	107.4	1613
n	112.8	106	107.4	16	107.4	1613

P:\09-0016-02 Rieder Road Phase II\119 CAD\CADD Sheets\09-0016-sht-signpanel22.dgn

SIGN DETAIL

1:75

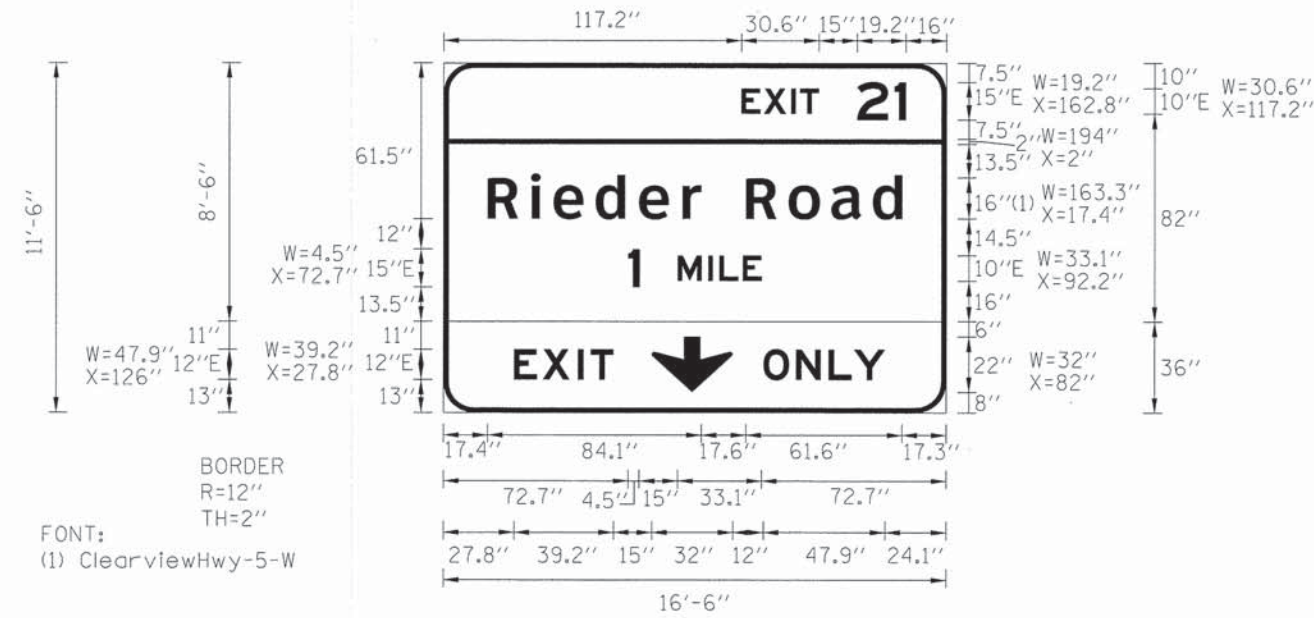

Panel Style: guide\_fwy\_overhead\_clear\_exit\_only.ssi  
 Dimensions are in inches.tenths

Letter locations are panel edge to lower left corner

SIGN NUMBER	STR NO 8C0821064R019.1
WIDTH x HGHT.	16'-6" x 11'-6"
BORDER WIDTH	2"
CORNER RADIUS	12"
MOUNTING	Overhead
BACKGROUND	TYPE: Reflective
	COLOR: Green/Yellow
LEGEND/BORDER	TYPE: Reflective
	COLOR: Black/White/Black

SYMBOL	ROT	X	Y	WID	HT
ARDDOWN	0	82	8	32	22

LETTER POSITIONS (X)

CHARACTER	LENGTH	SERIES/SIZE
E	64.8	E 2000
X	10.15	10,15
I	163.3	ClearviewHwy-5-W
T	1613	1613
2	52.6	E 2000
1	15.10	15,10
R	39.2	E 2000
i	12	12
e	47.9	E 2000
d	12	12
e		
r		
R		
o		
a		
d		
1		
M		
I		
L		
E		
E		
X		
I		
T		
O		
N		
L		
Y		

P:\09-0016\02 Rieder Road Phase I\110-CAD\CADD Sheets\09-0016-sh1-signpanel01.dgn

FILE NAME = 09-0016-sh1-signpanel01.dgn	USER NAME = IDOT	DESIGNED - SMS	REVISED -
MODEL NAME = Default	DRAWN - SMS	CHECKED - LDC	REVISED -
PLOT SCALE = 5.0000 ' / 1"	DATE - April 29, 2014		
PLOT DATE = 4/26/2014			

**STATE OF ILLINOIS  
DEPARTMENT OF TRANSPORTATION**

**RIEDER ROAD INTERCHANGE  
SIGN PANEL DETAIL**

SCALE: SHEET NO. 7 OF 22 SHEETS STA. TO STA.

F.A.I. RTE. 64	SECTION 09-00365-01-PV	COUNTY ST. CLAIR	TOTAL SHEETS 535	SHEET NO. 246
TR RTE. 222 (RIEDER ROAD)		CONTRACT NO. 97549		ILLINOIS











SIGN DETAIL

1:75

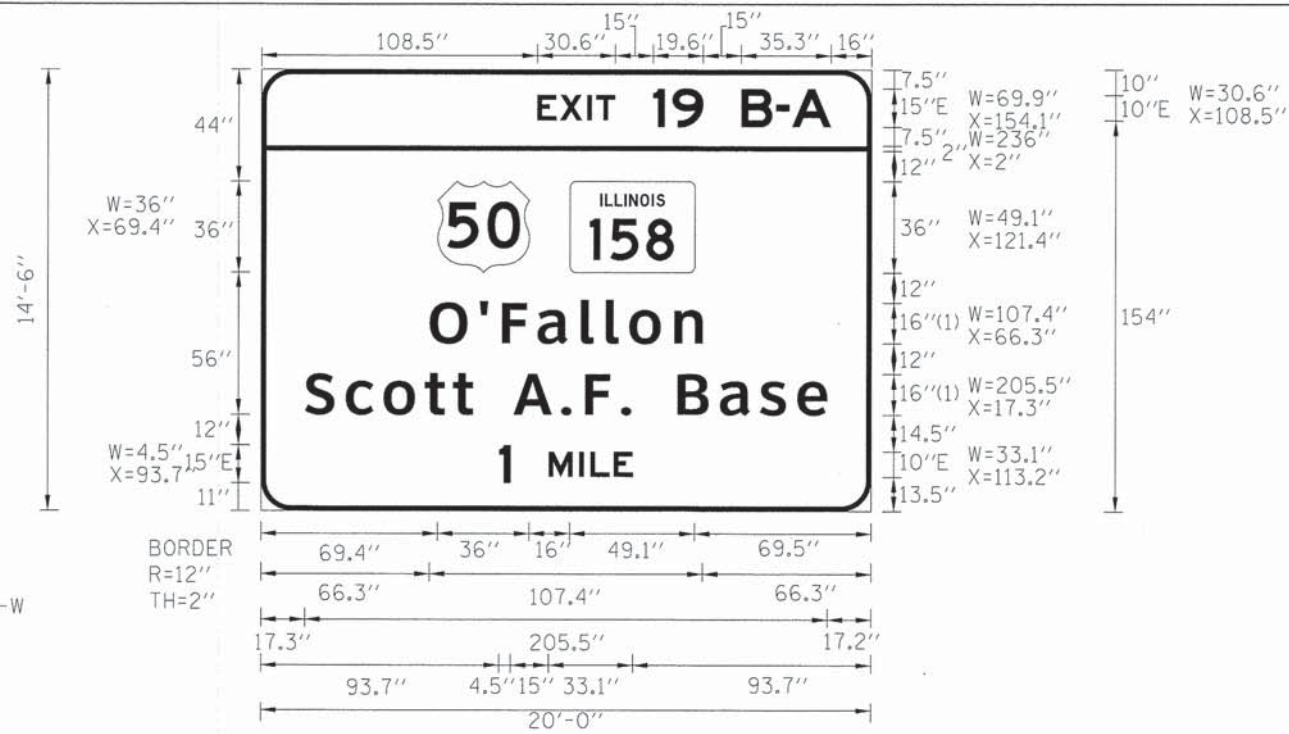

FONT:  
(1) ClearviewHwy-5-W

Panel Style: guide\_fwy\_intermediate\_clearview.ssi

Dimensions are in inches.tenths

Letter locations are panel edge to lower left corner

SIGN NUMBER	STR NO 8B0821064L020.4
WIDTH x HGHT.	20'-0" x 14'-6"
BORDER WIDTH	2"
CORNER RADIUS	12"
MOUNTING	Overhead
BACKGROUND	TYPE: ZZ Retro Reflective COLOR: Green
LEGEND/BORDER	TYPE: ZZ Retro Reflective COLOR: White/White

SYMBOL	ROT	X	Y	WID	HT
M1_4	0	69.4	94	36	36
M1-1100A-3-22-10	10	121.4	94	49.1	36

LETTER POSITIONS (X)

Letter	X	Y	WID	HT	Series/Size
E	108.5	117.4	128.1	131.6	E 2000
X	117.4	117.4	128.1	131.6	10,15
I	128.1	117.4	131.6	154.1	ClearviewHwy-5-W
T	131.6	117.4	131.6	154.1	16/13
1	154.1	117.4	161.6	173.7	ClearviewHwy-5-W
9	161.6	117.4	161.6	173.7	16/13
B	173.7	117.4	188.7	202.4	E 2000
-	188.7	117.4	188.7	202.4	15,10
A	202.4	117.4	202.4	208.7	
O	66.3	86	94.7	108.7	
F	86	86	94.7	108.7	
a	94.7	86	94.7	108.7	
l	108.7	86	125.7	135.6	
l	125.7	86	125.7	135.6	
o	135.6	86	144.8	162.6	
n	144.8	86	144.8	162.6	
S	17.3	33.3	48.2	64.4	
c	33.3	33.3	48.2	64.4	
o	48.2	33.3	48.2	64.4	
t	64.4	33.3	48.2	64.4	
t	75.5	33.3	48.2	64.4	
A	83.4	33.3	48.2	64.4	
.	99.4	33.3	48.2	64.4	
F	118.1	33.3	48.2	64.4	
B	127.5	33.3	48.2	64.4	
a	141.6	33.3	48.2	64.4	
s	145.6	33.3	48.2	64.4	
e	163.9	33.3	48.2	64.4	
1	17.3	113.2	125.2	129.6	
M	33.3	113.2	125.2	129.6	
I	48.2	113.2	125.2	129.6	
L	64.4	113.2	125.2	129.6	
E	75.5	113.2	125.2	129.6	

F:\gpr\0016\02\_Rieder\_Road\_Phase\_1\1118\_CAD\CAD00\_Sheets\01-0016-sh1-signpanel06.dgn















**SIGN DETAIL**

1:75

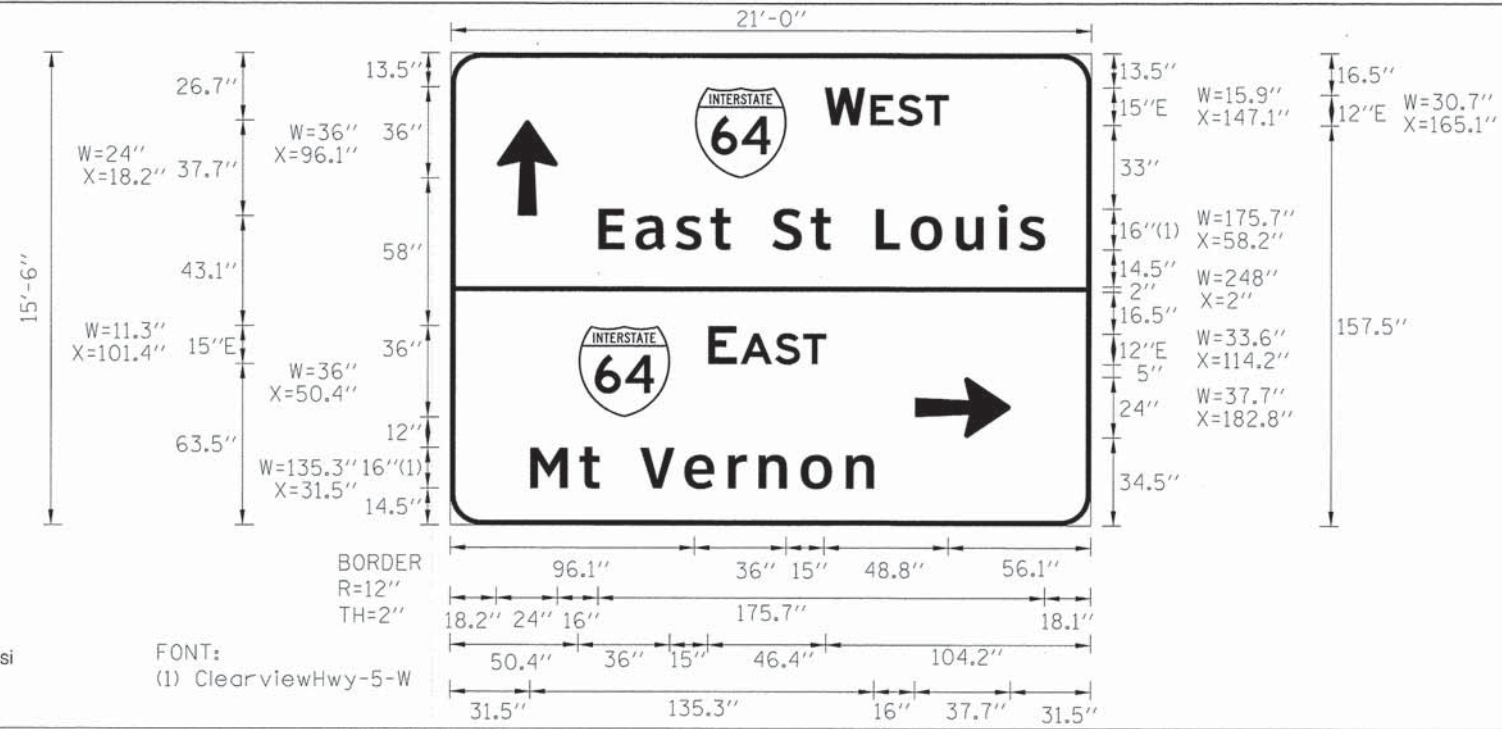

Panel Style: guide\_fwy\_intermediate\_clearview.ssi  
 Dimensions are in inches.tenths

FONT:  
 (1) ClearviewHwy-5-W

Letter locations are panel edge to lower left corner

SIGN NUMBER	STA 45+80
WIDTH x HGHT.	21'-0" x 15'-6"
BORDER WIDTH	2"
CORNER RADIUS	12"
MOUNTING	Ground
BACKGROUND	TYPE: Reflective
	COLOR: Green
LEGEND/BORDER	TYPE: Reflective
	COLOR: White/White

SYMBOL	ROT	X	Y	WID	HT
M1_1	0	96.1	136.5	36	36
AR_Type A	0	18.2	121.7	23.9	37.7
M1_1	0	50.4	42.5	36	36
AR_Type A	270	182.8	34.6	23.9	37.7

**LETTER POSITIONS (X)**

W	E	S	T											LENGTH	SERIESSIZE
147.1	165.1	175.8	186.9											48.8	E 2000 15,12
58.2	72.7	88.5	102.2	110.1	126.6	141.7	149.5	167.3	181	198.8	215.5	223.7	175.7	ClearviewHwy-5-W 1613	
101.4	114.2	127.8	138.8											46.4	E 2000 15,12
31.5	50.8	58.7	74.7	92.1	109.3	121.3	137.9	155.7						135.3	ClearviewHwy-5-W 1613

P:\09-0016-02 Rieder Road Phase 1\18 CAD\CADD Sheets\09-0016-sht-signpanel13.dgn

FILE NAME = 09-0016-sht-signpanel13.dgn	USER NAME = IDOT	DESIGNED - SMS	REVISED -
MODEL NAME = Default	DRAWN - SMS	CHECKED - LDC	REVISED -
PLOT SCALE = 5.0000' / in.	DATE - Apr/29, 2014		

**STATE OF ILLINOIS  
 DEPARTMENT OF TRANSPORTATION**

**RIEDER ROAD INTERCHANGE  
 SIGN PANEL DETAIL**

SCALE: SHEET NO. 19 OF 22 SHEETS STA. TO STA.

F.A.I. RTE.	SECTION	COUNTY	TOTAL SHEETS	SHEET NO.
64	09-00365-01-PV	ST. CLAIR	535	258
TR RTE. 222 (RIEDER ROAD)			CONTRACT NO. 97549	
ILLINOIS				





**SIGN DETAIL**

1:75

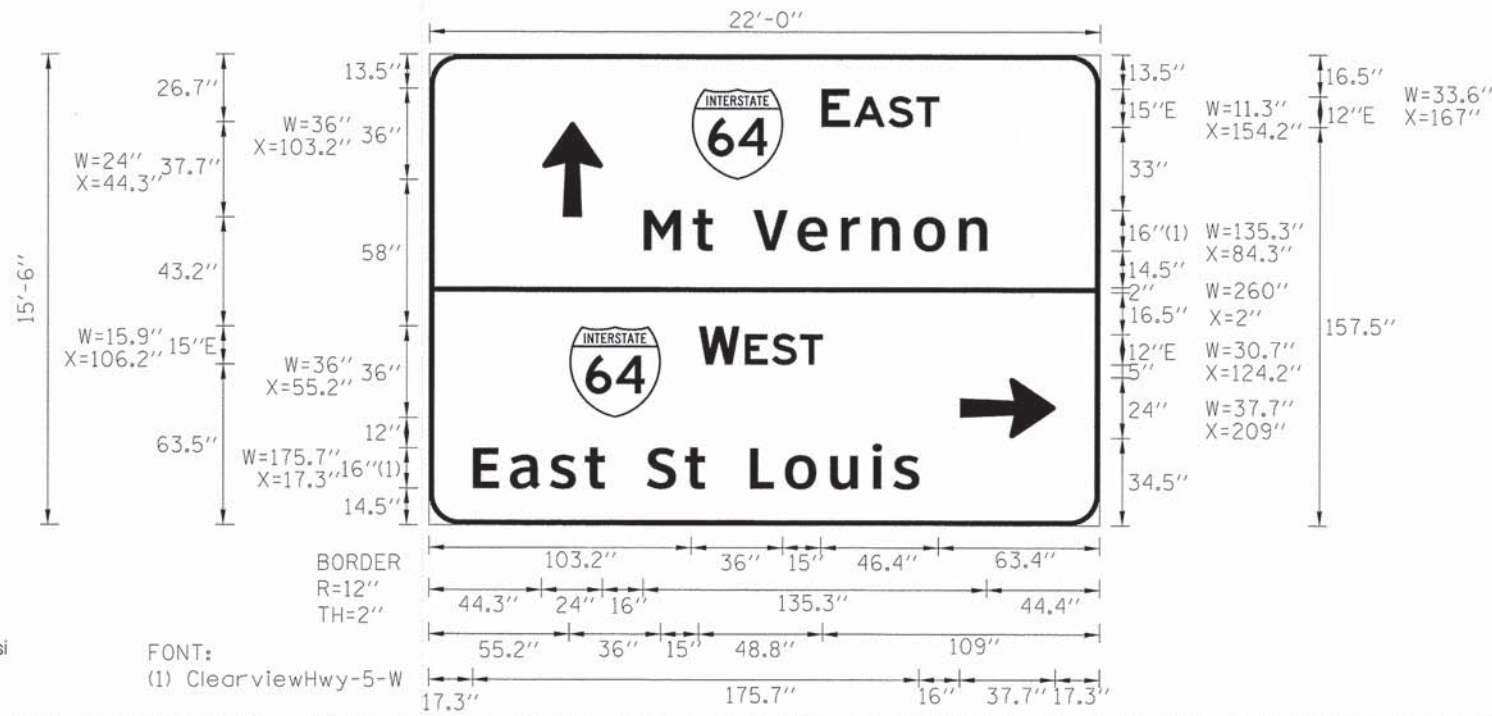

Panel Style: guide\_fwy\_intermediate\_clearview.ssi  
 Dimensions are in inches.tenths

FONT:  
 (1) ClearviewHwy-5-W

Letter locations are panel edge to lower left corner

SIGN NUMBER	STA 58+60
WIDTH x HGHT.	22'-0" x 15'-6"
BORDER WIDTH	2"
CORNER RADIUS	12"
MOUNTING	Ground
BACKGROUND	TYPE: ZZ Retro Reflective COLOR: Green
LEGEND/BORDER	TYPE: ZZ Retro Reflective COLOR: White/White

SYMBOL	ROT	X	Y	WID	HT
M1_1	0	103.2	136.5	36	36
AR_Type A	0	44.3	121.6	24	37.7
M1_1	0	55.2	42.5	36	36
AR_Type A	270	209	34.5	24	37.7

**LETTER POSITIONS (X)**

													LENGTH	SERIESSIZE
E	A	S	T										46.4	E 2000
154.2	167	180.6	191.6											15,12
M	t		V	e	r	n	o	n					135.3	ClearviewHwy-5-W
84.3	103.6	111.5	127.5	144.9	162.1	174.1	190.7	208.5						1613
W	E	S	T										48.8	E 2000
106.2	124.2	134.9	146											15,12
E	a	s	t		S	t		L	o	u	i	s	175.7	ClearviewHwy-5-W
17.3	31.8	47.6	61.3	69.2	85.7	100.8	108.6	126.4	140.1	157.9	174.6	182.8		1613

P:\09-2016-02 Rieder Road Phase 1\118 CAD\CADD Sheets\09-2016-sht-signpanel116.dgn

Roadway	Station	A	B	C	D
I-64	948+00	20.0	14.5	5	30
I-64	1018+00	16.5	9.5	7	27
I-64	1020+00	18.5	9.0	5	35
I-64	1041+00	16.5	8.5	5	30
I-64	1093+00	16.5	8.5	5	30
Ramp A	14+50	24.5	5.0	8.4	30
Ramp C	13+50	24.5	5.0	7	18
Rieder Road	45+80	21.0	10.3	5	30
Rieder Road	48+60	18.5	8.0	5	30
Rieder Road	55+85	22.0	8.0	5	30
Rieder Road	58+60	22.0	15.5	5	30

- C \* (A) For signs less than 30'(9.1m) from edge of pavement, the bottom edge of Sign shall be set level at an elevation of at least 7'(2.1m) above grade Elevation at edge of pavement.
- (B) For signs 30'(9.1m) and greater from edge of pavement, the bottom edge of sign shall be set level at an elevation of at least 5'(1.5m) above grade elevation at edge of pavement.
- (C) For signs on rising embankmentslopes, the bottom edge of the sign shall be set so as to obtain at least 7'(2.1 m) between the top of the stub post and the slot at the fuse plate on the far post. This may be reduced to 5'(1.5m) when the distance from the edge of pavement is 30'(9.1m) or greater and the slope is 1:2 or steeper or where it would be unlikely for an out of control vehicle to reach the post.
- D \*\* All signs will be placed 35'(10.7m) or more off of main line wherever possible, except when placed behind guardrail. Signs on ramps will be placed 18'(5.5m) or more off the edge of pavement.
- In general, the location of shoulder mounted signs may vary in order to take advantage of flatter cross sections which can result in considerable cost savings.

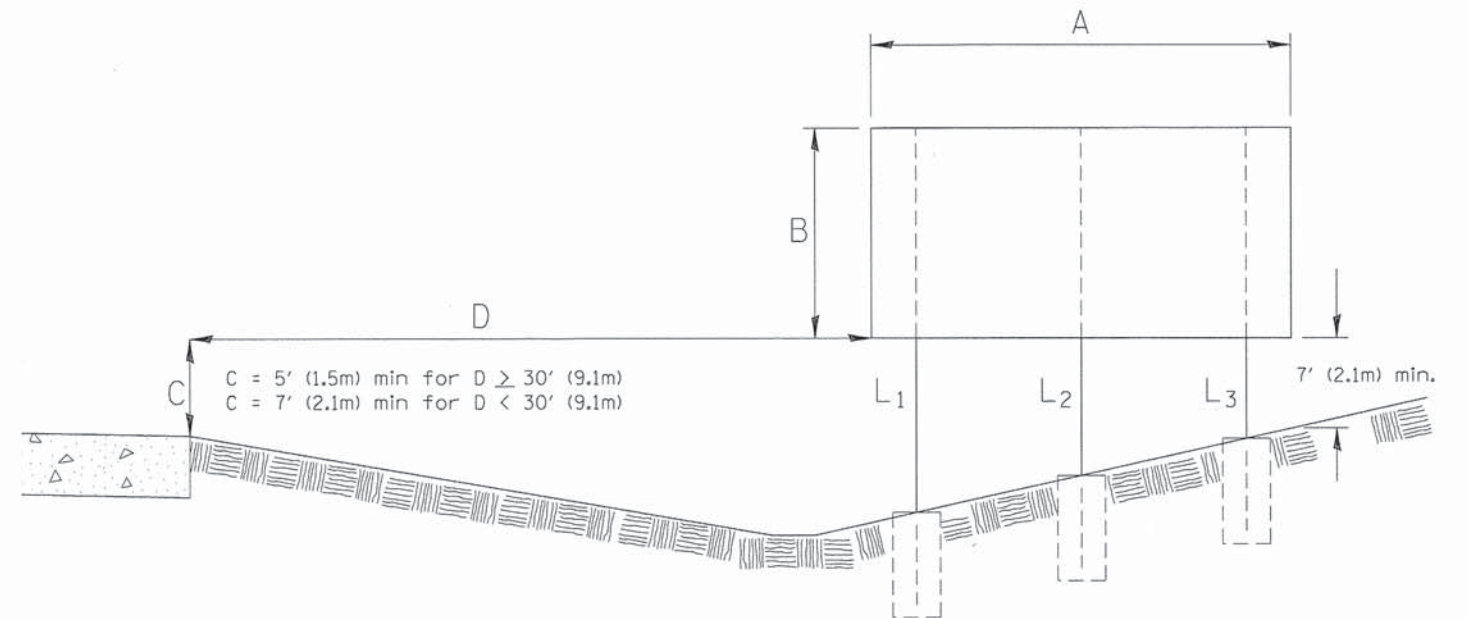

L<sub>1</sub> is always the post nearest to the edge of pavement. (See Sign Structures Manual)

7' (2.1m) min. between top of stud post & fuse plate. May be reduced to 5' (1.5m) when D = 30' (9.1m) & the slope is 1:2 or steeper or where it would be unlikely for an out of control vehicle to reach the post.

All post sizes and support lengths shown on plans shall be verified in field prior to construction.

All post sizes will be verified by the I.D.O.T. Shoulder Mounted Sign Post Stress Analysis (See Special Provisions).

All slope ratios are expressed as units of vertical displacement to units of horizontal displacement (V:H).

All dimensions are in inches (millimeters) unless otherwise noted.

DESIGNER NOTES:  
1. Include District Special Provision.  
2. Check w/Bureau of Operations for current policies.  
3. Designer fill in table.

FILE NAME = 09-0016-sht-signschedulm01.dgn	USER NAME = IDOT	DESIGNED - SMS	REVISED -
MODEL NAME = Default	DRAWN - TJH	CHECKED - LDC	REVISED -
PLOT SCALE = 1:0000' / 1"	DATE - April 29, 2014		
PLOT DATE = 4/26/2014			

STATE OF ILLINOIS  
DEPARTMENT OF TRANSPORTATION

SIGN PANEL PLACEMENT SCHEDULE

SCALE: SHEET NO. 1 OF 1 SHEETS STA. TO STA.

F.A.I. RTE.	SECTION	COUNTY	TOTAL SHEETS	SHEET NO.
64	09-00365-01-PV	ST. CLAIR	535	262
TR RTE. 222 (RIEDER ROAD)		CONTRACT NO. 97549		
[ILLINOIS]				

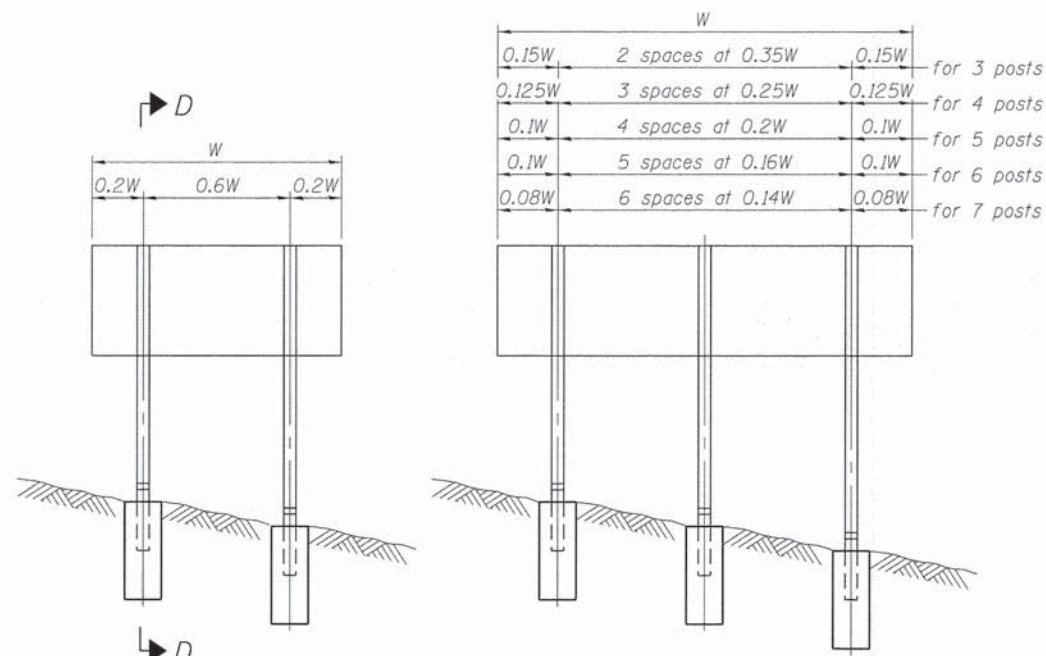

0.15W	2 spaces at 0.35W	0.15W	for 3 posts
0.125W	3 spaces at 0.25W	0.125W	for 4 posts
0.1W	4 spaces at 0.2W	0.1W	for 5 posts
0.1W	5 spaces at 0.16W	0.1W	for 6 posts
0.08W	6 spaces at 0.14W	0.08W	for 7 posts

ELEVATION

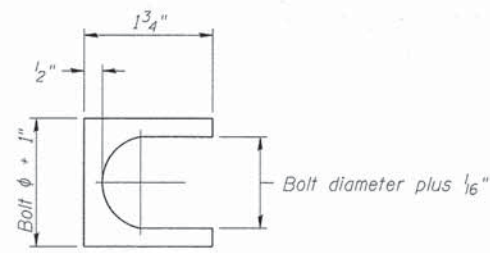

SHIM DETAIL  
Furnish two 0.01" thick and two 0.03" thick stainless steel or brass (ASTM B36) shims per post.

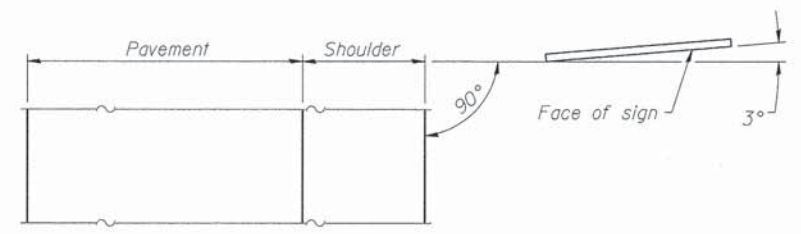

LOCATION SKETCH

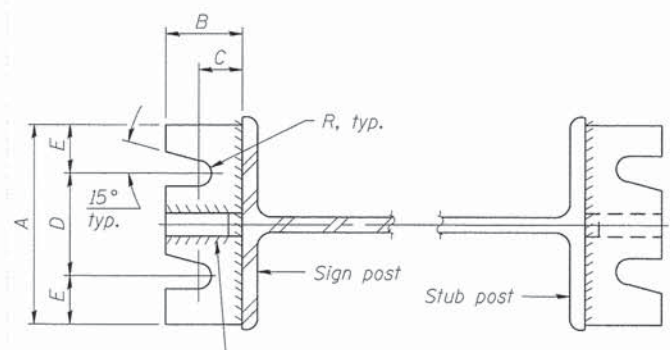

SECTION A-A

SECTION B-B

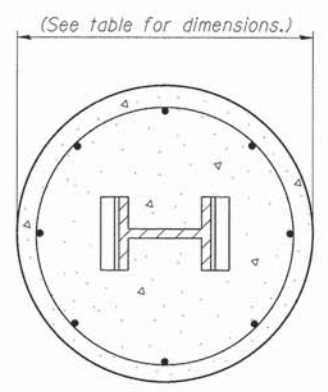

SECTION C-C

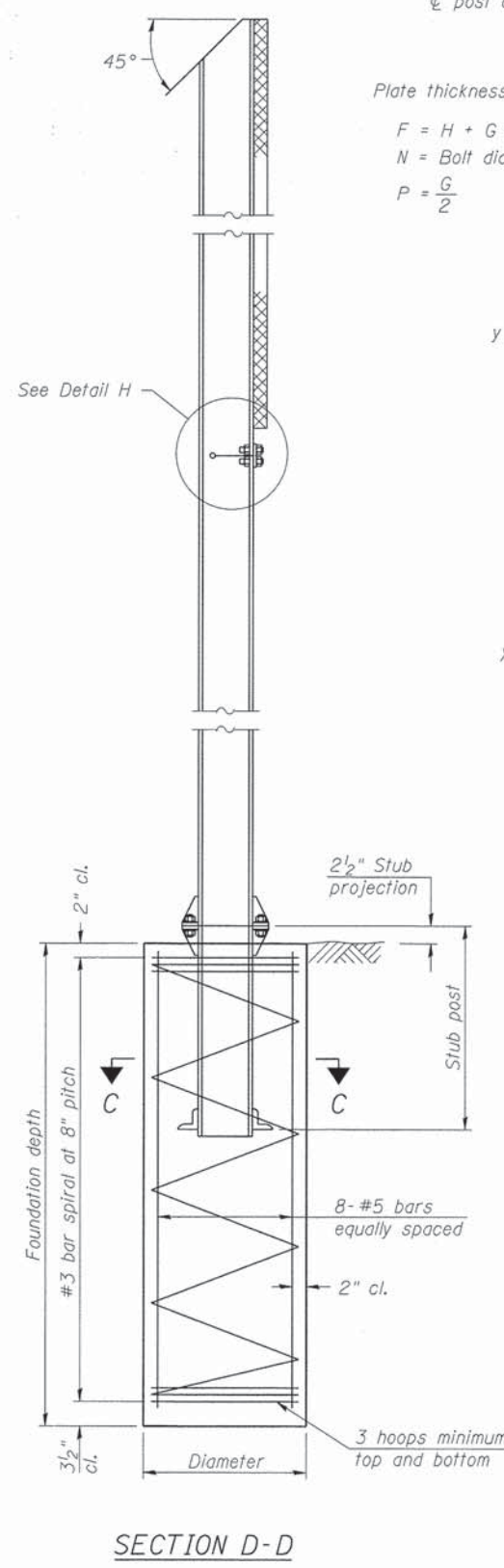

SECTION D-D

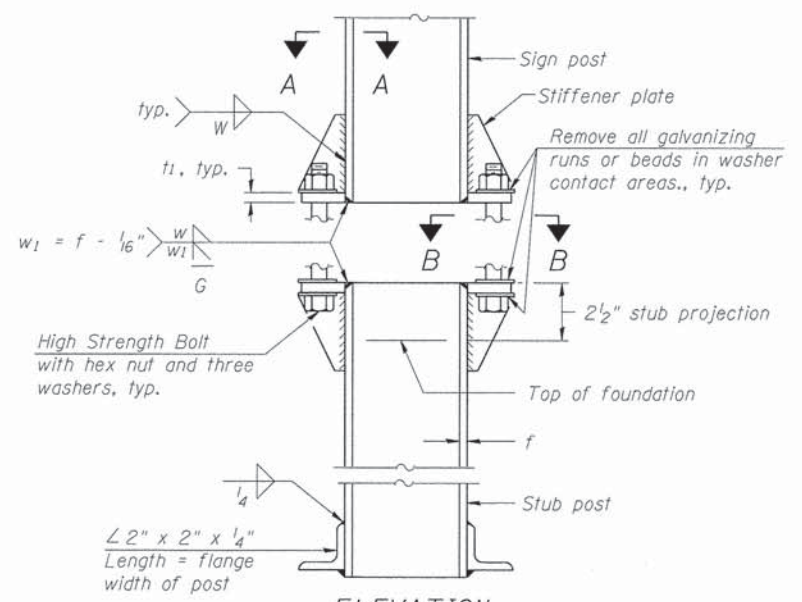

ELEVATION  
SIGN POST & STUB POST

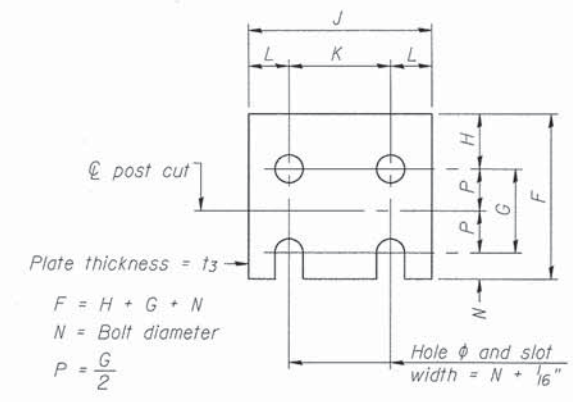

FUSE PLATE DETAIL  
(Install with notches down.)

N = Bolt Diameter	G	H
1/2"	2"	1 1/8"
5/8"	2 1/4"	1 1/4"
3/4"	2 1/2"	1 3/8"
7/8"	2 3/4"	1 1/2"
1"	3"	1 5/8"
1 1/8"	3 1/4"	1 3/4"
1 1/4"	3 1/2"	1 7/8"

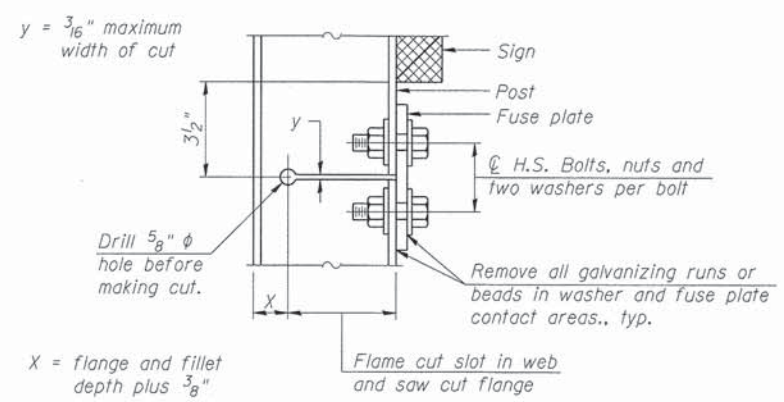

DETAIL H

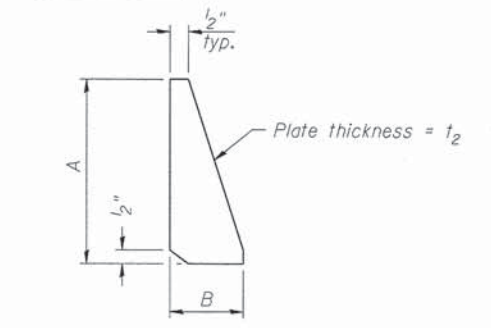

STIFFENER PLATE DETAIL

GENERAL NOTES

Posts shall be plumbed by using shims with post-to-stub post connection bolts snug tight only. Final tightening of all High Strength Bolts shall be in accordance with Article 727.05 and threads at the junction of the bolt and nut shall be burred or center punched to prevent the nut from loosening.

LOADING: 80 m.p.h. wind with 30% gust factor, normal to sign.

DESIGN STRESSES:  
Structural steel - 20,000 p.s.i.  
Reinforcing steel - 20,000 p.s.i.  
Concrete - 1,400 p.s.i.  
Footing soil pressure - 2,000 p.s.f.

After fabrication, the post, fuse plate and upper 6", min. of the stub post shall be hot-dip galvanized in accordance with AASHTO M111. All bolts, nuts and washers shall be hot-dip galvanized in accordance with AASHTO M232.

Work this sheet with Base Sheet BAW-A-2.

BAW-A-1

6-1-12

(Sheet 1 of 2)

FILE NAME = 09-0016-sht-signbowdetails01.dgn	USER NAME = IDOT	DESIGNED - SMS	REVISED -
MODEL NAME = Default	DRAWN - TJH	REVISIONS -	
PLOT SCALE = 1.0000' / in.	CHECKED - LDC	REVISIONS -	
PLOT DATE = 4/26/2014	DATE - Apr 11 29, 2014	REVISIONS -	

STATE OF ILLINOIS  
DEPARTMENT OF TRANSPORTATION

BREAK-AWAY WIDE FLANGE  
STEEL SIGN POST DETAILS

SCALE: SHEET NO. 1 OF 2 SHEETS STA. TO STA.

F.A.I. RTE.	SECTION	COUNTY	TOTAL SHEETS	SHEET NO.
64	09-00365-01-PV	ST. CLAIR	535	263
TR RTE. 222 (RIEDER ROAD)		CONTRACT NO. 97549		
ILLINOIS				

POST	CONCRETE FOUNDATION TABLE							POST TO STUB POST CONNECTION DATA										FUSE PLATE DATA				
	Foundation			Reinforcement			Stub Post Length	Bolt Size	A	B	C	D	E	t <sub>1</sub>	t <sub>2</sub>	R	W	J	K	L	t <sub>3</sub>	
	Diameter	* Minimum Depth	Concrete (1) cu. yds.	Vertical Bars Length	Bar Spirals Diameter	Bar Spirals Length																lbs. (2)
W6x9	2'-0"	6'-0"	0.70	5'-9"	1'-8 1/2"	79'-0"	78	2'-3"	5/8" x 3 1/4"	6"	2 1/4"	1 1/4"	3 1/2"	1 1/4"	3/4"	1/2"	1 1/2"	1 1/4"	4"	2 1/4"	7/8"	1/4"
W6x15	2'-0"	6'-0"	0.70	5'-9"	1'-8 1/2"	79'-0"	78	2'-6"	5/8" x 3 1/4"	6"	2 1/4"	1 1/4"	3 1/2"	1 1/4"	3/4"	1/2"	1 1/2"	1 1/4"	6"	3 1/2"	1 1/4"	3/8"
W8x18	2'-0"	6'-0"	0.70	5'-9"	1'-8 1/2"	79'-0"	78	2'-6"	3/4" x 3 3/4"	6"	2 1/2"	1 3/8"	3 1/4"	1 3/8"	1"	1/2"	1 1/2"	1 1/4"	5 1/4"	2 3/4"	1 1/4"	3/8"
W10x22	2'-6"	6'-6"	1.18	6'-3"	2'-2 1/2"	105'-0"	92	3'-0"	3/4" x 3 3/4"	6"	2 1/2"	1 3/8"	3 1/4"	1 3/8"	1"	1/2"	1 1/2"	1 1/4"	5 3/4"	2 3/4"	1 1/2"	1/2"
W10x26	2'-6"	7'-0"	1.27	6'-9"	2'-2 1/2"	112'-0"	98	3'-0"	7/8" x 4"	7"	2 3/4"	1 1/2"	4"	1 1/2"	1"	3/4"	1 1/2"	5 3/4"	2 3/4"	1 1/2"	5/8"	
W12x26	2'-6"	7'-9"	1.41	7'-6"	2'-2 1/2"	119'-0"	107	3'-0"	7/8" x 4"	7"	2 3/4"	1 1/2"	4"	1 1/2"	1"	3/4"	1 1/2"	5 3/4"	2 3/4"	1 1/2"	5/8"	
W14x30	3'-0"	7'-3"	1.90	7'-0"	2'-8 1/2"	145'-0"	113	3'-0"	7/8" x 4"	7"	2 3/4"	1 1/2"	4"	1 1/2"	1"	3/4"	1 1/2"	5 3/4"	2 3/4"	1 1/2"	5/8"	
W14x38	3'-0"	8'-0"	2.09	7'-9"	2'-8 1/2"	153'-0"	122	3'-6"	1" x 4 1/2"	7 1/2"	3"	1 3/4"	4"	1 3/4"	1 1/4"	3/4"	1 1/2"	5 3/4"	2 3/4"	1 1/2"	5/8"	
W16x45	3'-0"	8'-6"	2.23	8'-3"	2'-8 1/2"	162'-0"	130	3'-6"	1" x 4 1/2"	7 1/2"	3"	1 3/4"	4"	1 3/4"	1 1/4"	3/4"	1 1/2"	5 3/4"	2 3/4"	1 1/2"	5/8"	

\*Dimensional changes required for varying site conditions shall be approved by the Engineer.

POST	FUSE PLATE BOLT SIZE																				
	Sign Height																				
	4'-0"	5'-0"	6'-0"	7'-0"	8'-0"	9'-0"	10'-0"	11'-0"	12'-0"	13'-0"	14'-0"	15'-0"	16'-0"	17'-0"	18'-0"	19'-0"	20'-0"	21'-0"	22'-0"	23'-0"	24'-0"
W6x9	1/2" x 1 1/2"	1/2" x 1 1/2"	1/2" x 1 1/2"	1/2" x 1 1/2"	---	---	---	---	---	---	---	---	---	---	---	---	---	---	---	---	
W6x15	1/2" x 1 3/4"	1/2" x 1 3/4"	1/2" x 1 3/4"	5/8" x 2"	5/8" x 2"	3/4" x 2"	3/4" x 2"	3/4" x 2"	3/4" x 2"	3/4" x 2"	---	---	---	---	---	---	---	---	---	---	
W8x18	1/2" x 1 3/4"	1/2" x 1 3/4"	1/2" x 1 3/4"	1/2" x 1 3/4"	5/8" x 2"	5/8" x 2"	3/4" x 2"	3/4" x 2"	3/4" x 2"	3/4" x 2"	---	---	---	---	---	---	---	---	---	---	
W10x22	1/2" x 2"	1/2" x 2"	1/2" x 2"	1/2" x 2"	1/2" x 2"	5/8" x 2"	5/8" x 2"	3/4" x 2 1/4"	3/4" x 2 1/4"	3/4" x 2 1/4"	3/4" x 2 1/4"	3/4" x 2 1/4"	3/4" x 2 1/4"	---	---	---	---	---	---	---	
W10x26	1/2" x 2"	1/2" x 2"	1/2" x 2"	1/2" x 2"	1/2" x 2"	5/8" x 2 1/4"	5/8" x 2 1/4"	3/4" x 2 1/2"	3/4" x 2 1/2"	3/4" x 2 1/2"	3/4" x 2 1/2"	3/4" x 2 1/2"	3/4" x 2 1/2"	3/4" x 2 1/2"	---	---	---	---	---	---	
W12x26	1/2" x 2"	1/2" x 2"	1/2" x 2"	1/2" x 2"	1/2" x 2"	5/8" x 2 1/4"	5/8" x 2 1/4"	3/4" x 2 1/2"	3/4" x 2 1/2"	3/4" x 2 1/2"	3/4" x 2 1/2"	3/4" x 2 1/2"	3/4" x 2 1/2"	3/4" x 2 1/2"	3/4" x 2 1/2"	---	---	---	---	---	
W14x30	1/2" x 2"	1/2" x 2"	1/2" x 2"	1/2" x 2"	1/2" x 2"	5/8" x 2"	5/8" x 2"	3/4" x 2 1/4"	3/4" x 2 1/4"	3/4" x 2 1/4"	3/4" x 2 1/4"	3/4" x 2 1/4"	3/4" x 2 1/4"	3/4" x 2 1/4"	3/4" x 2 1/4"	3/4" x 2 1/4"	---	---	---	---	
W14x38	1/2" x 2"	1/2" x 2"	1/2" x 2"	1/2" x 2"	1/2" x 2"	5/8" x 2 1/4"	5/8" x 2 1/4"	3/4" x 2 1/2"	3/4" x 2 1/2"	3/4" x 2 1/2"	3/4" x 2 1/2"	7/8" x 2 1/2"	7/8" x 2 1/2"	1" x 2 3/4"	1" x 2 3/4"	1" x 2 3/4"	1" x 2 3/4"	1" x 2 3/4"	1" x 2 3/4"	1" x 2 3/4"	1" x 2 3/4"
W16x45	---	1/2" x 2"	1/2" x 2"	1/2" x 2"	1/2" x 2"	1/2" x 2"	1/2" x 2"	5/8" x 2 1/4"	5/8" x 2 1/4"	5/8" x 2 1/4"	3/4" x 2 1/2"	3/4" x 2 1/2"	7/8" x 2 1/2"	7/8" x 2 1/2"	1" x 2 3/4"	1" x 2 3/4"	1" x 2 3/4"	1" x 2 3/4"	1" x 2 3/4"	1" x 2 3/4"	1" x 2 3/4"

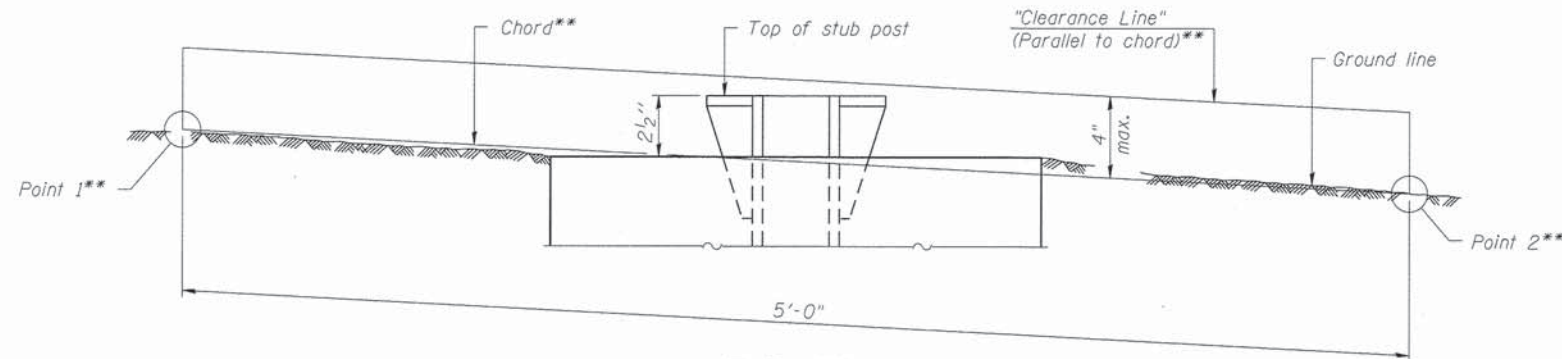

ELEVATION  
GROUND LINE & STUB POST

\*\* For all "Point 1" and "Point 2" locations, "Clearance Line" must be at or above top of stub post.

- (1) Quantity includes all concrete necessary for one foundation.
- (2) Includes reinforcement bars and spiral hooping for one foundation.

BAW-A-2

6-1-12

(Sheet 2 of 2)

FILE NAME = 09-0216-ahs-signbowdetails02.dgn  
 USER NAME = IDOT  
 MODEL NAME = Default  
 PLOT SCALE = 1:8000  
 PLOT DATE = 4/26/2014

DESIGNED - SMS  
 DRAWN - TJH  
 CHECKED - LDC  
 DATE - April 29, 2014

REVISED -  
 REVISED -  
 REVISED -  
 REVISED -

STATE OF ILLINOIS  
 DEPARTMENT OF TRANSPORTATION

BREAK-AWAY WIDE FLANGE  
 STEEL SIGN POST TABLES

SCALE: SHEET NO. 2 OF 2 SHEETS STA. TO STA.

F.A.I. RTE.	SECTION	COUNTY	TOTAL SHEETS	SHEET NO.
64	09-00365-01-PV	ST. CLAIR	535	264
TR RTE. 222 (RIEDER ROAD)			CONTRACT NO. 97549	
ILLINOIS				



**GENERAL NOTES**

**SPECIFICATIONS:**

**DESIGN:** AASHTO Standard Specifications for Structural Supports for Highway Signs, Luminaires and Traffic Signals. ("AASHTO Specifications") ②

**CONSTRUCTION:** Current (at time of letting) Illinois Department of Transportation Standard Specifications for Road and Bridge Construction, Supplemental Specifications and Special Provisions. ("Standard Specifications")

**LOADING:** 90 M.P.H. WIND VELOCITY

**WALKWAY LOADING:** Dead load plus 500 lbs. concentrated live load.

**MINIMUM CLEARANCE:** 3" greater than bridge members at all locations. (All Obstructions)

**WELDING:** All welds to be continuous unless otherwise shown. All welding to be done in accordance with current AWS D1.1 Structural Welding Code (Steel) and the Standard Specifications.

**MATERIALS:** All Structural Steel Pipe shall be ASTM A53 Grade B with a minimum yield of 35,000 p.s.i., or A500 Grade B or C with a minimum yield of 46,000 p.s.i. If A500 pipe is substituted for A53, then the outside diameter shall be as detailed and wall thickness greater than or equal to A53.  
All Structural Steel Plates and Shapes shall conform to AASHTO M270 Gr. 36, Gr. 50 (M183, M223 Gr. 50.).

**HIGH STRENGTH BOLTS:** All bolts, washers, nuts and locknuts shall satisfy the requirements of ASTM designation A307 unless noted as "H.S." which shall require AASHTO M164 (A325), ASTM A449, or approved alternate. All fasteners shall be hot dip galvanized per AASHTO M232 unless otherwise specified.

**GALVANIZING:** All Steel Grating, Plates, Shapes and Pipe shall be Hot Dip Galvanized after fabrication in accordance with AASHTO M111. Painting is not permitted.

**ANCHOR RODS:** All-threaded rod shall conform to ASTM F1554 Grade 105, 3/4"  $\phi$  x 12" long, each with one plate washer and locknut and be hot dip galvanized per AASHTO M232. They shall be either cast into the concrete or epoxy grouted in accordance with Section 584 of the Standard Specifications. Minimum embedment in concrete shall be 9".

- ① Bracket spacing  $g \leq 6'-0"$ , max. Spacing shall be uniform if possible but may vary  $\pm 6"$  to miss existing obstruction (rail post, light poles, web stiffeners, splice plates, etc.). Adjust bracket lengths accordingly on skewed structures.
- ② Any design modifications shall be based on the current version of applicable specifications and submitted for the Engineer's approval.
- ③ Unit price includes grating, handrail, brackets, supports, anchor bolts, fasteners, fabrication, delivery, erection, field drilling and other necessary items. Limits of payment are based on grating length ( $c_w$ ,  $d_w$ ) unless otherwise specified. For Safety Chain Details and Details D, F and G, see Base Sheet BM-4.
- ④ If walkway bracket at safety chain location is behind sign, add angle to bracket. See detail on Base Sheet BM-4.

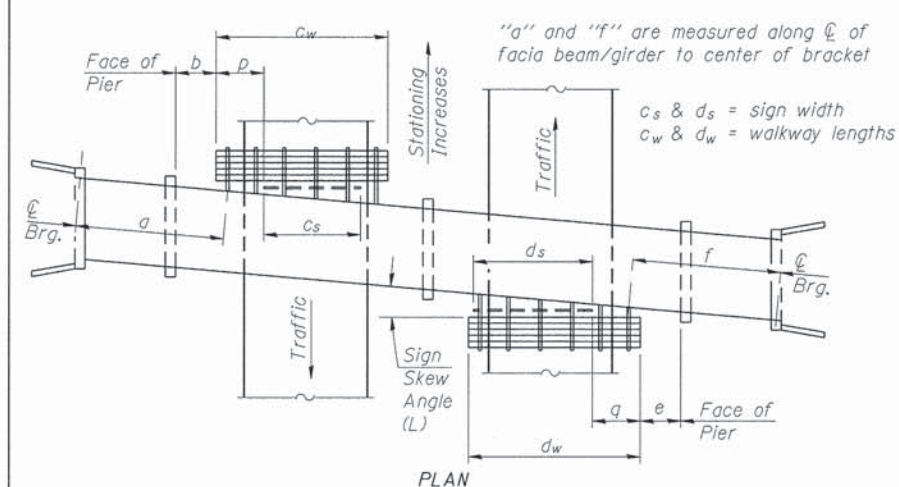

**WALKWAY AND HANDRAIL SKETCH**  
(Road plan beneath structure varies.)

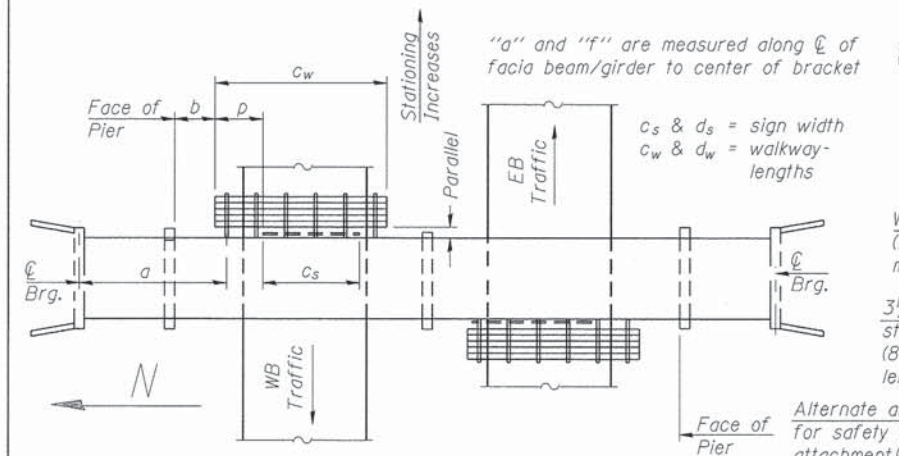

**WALKWAY AND HANDRAIL SKETCH**  
(Road plan beneath structure varies.)

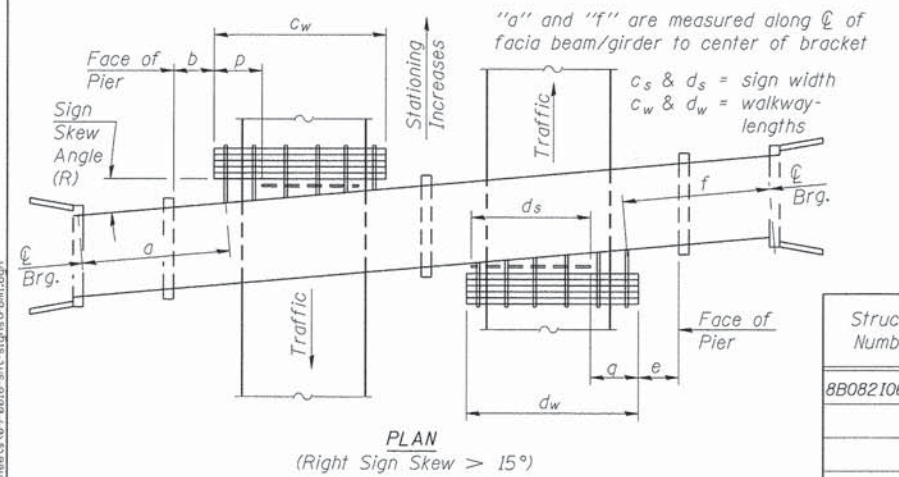

**WALKWAY AND HANDRAIL SKETCH**  
(Road plan beneath structure varies.)

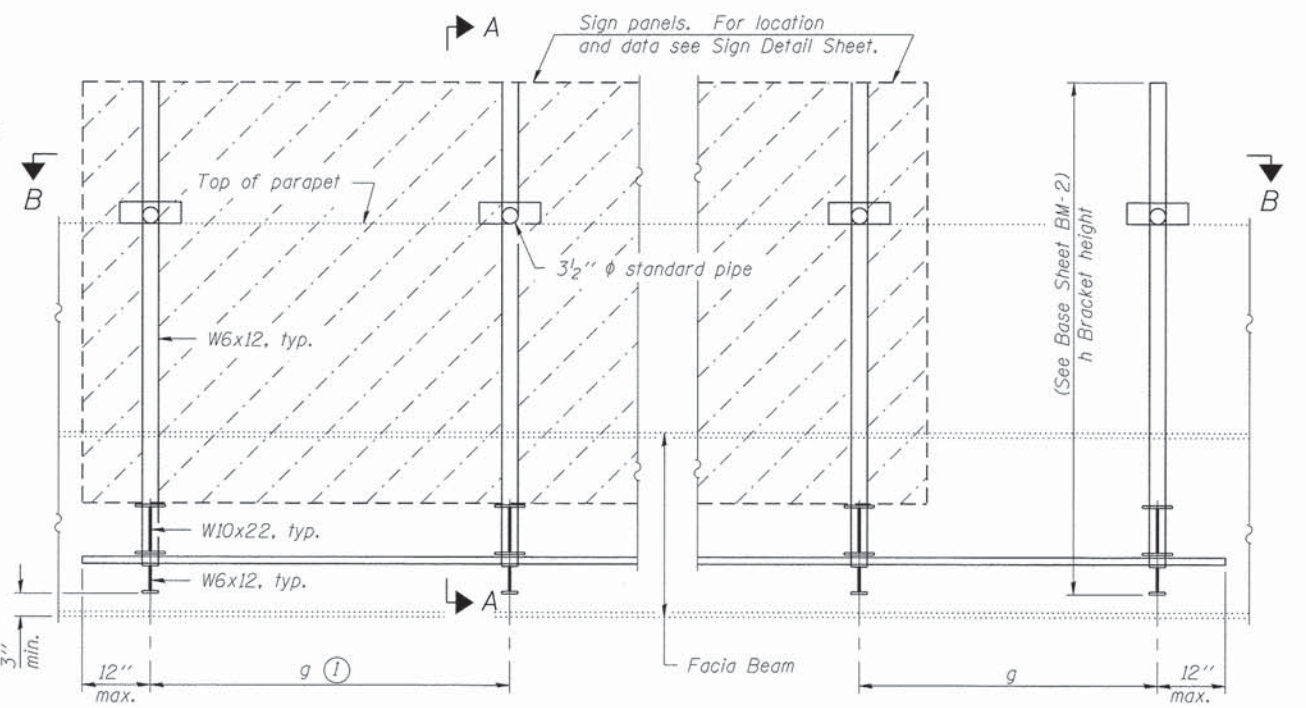

**TYPICAL FRONT ELEVATION**  
(With lights, safety chain and handrail omitted for clarity.)

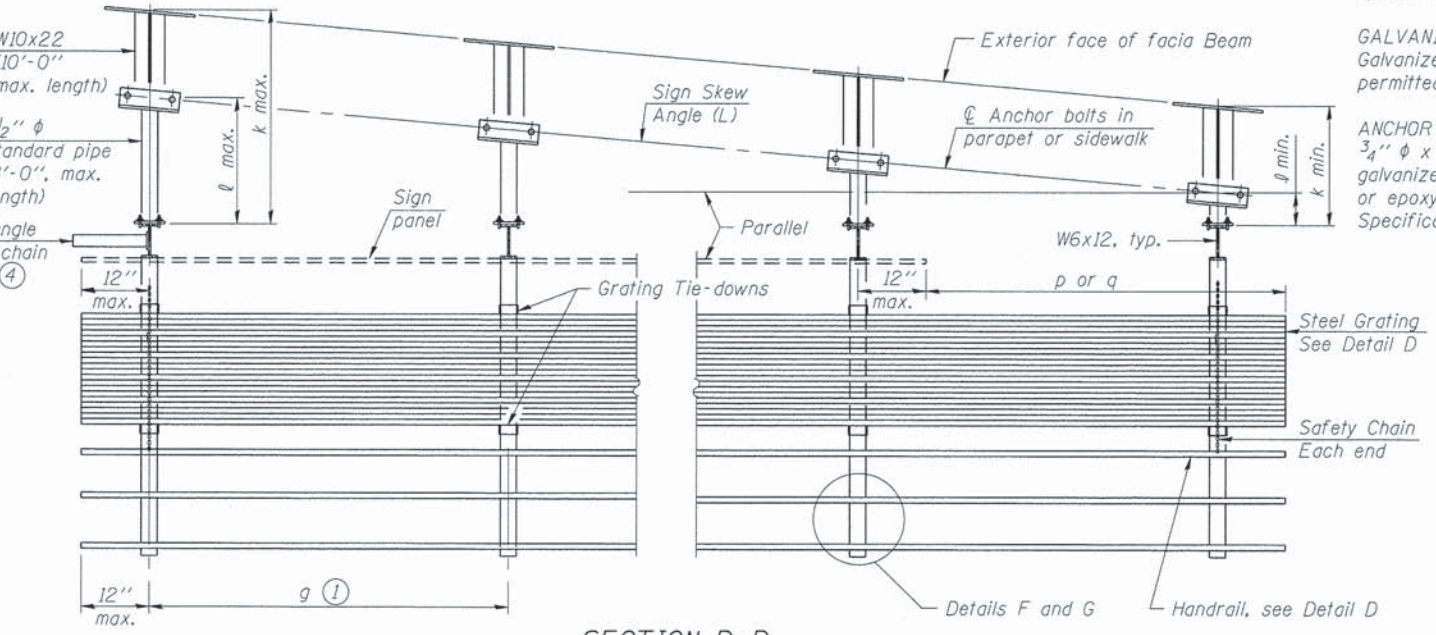

**SECTION B-B**  
(Shown: Left Sign Skew > 15 degrees)

Structure Number	Sign Skew Angle (L) or (R)	Bridge Station	Bridge Structure Number	Contract Route Designation	a	b	c <sub>s</sub>	c <sub>w</sub>	d <sub>s</sub>	d <sub>w</sub>	e	f	g	No. of Brackets (Total)	p	q	Total Grating/Hndrl. Lengths (c <sub>w</sub> + d <sub>w</sub> )
8B0821064L020.4	0°	997+90.18	SN082-0285	FA1 64	47	N/A	20	32	X	X	X	X	6	6	12	X	32

Dimensions a, b, e, f & g may vary as approved by the Engineer, see ①.  
When  $c_w < c_s$  and/or  $d_w < d_s$ , use alternate brackets without walkway supports where applicable, see ③.

**TOTAL BILL OF MATERIAL**

③ OVERHEAD SIGN STRUCTURE - BRIDGE MOUNTED	Foot	32
--	------	----

FILE NAME = 09-0016-02 Rieder Road Phase 11V10.CADD.DWG Sheets\09-0016-sh1-signstr-bml.dgn

BM-1

6-1-12

USER NAME = IDOT	DESIGNED - JAH	REVISD -
MODEL NAME = Default	DRAWN - TJH	REVISD -
PLOT SCALE = 12.0000' / ft.	CHECKED - LDC	REVISD -
PLOT DATE = 4/26/2014	DATE - April 29, 2014	REVISD -

**STATE OF ILLINOIS**  
**DEPARTMENT OF TRANSPORTATION**

**BRIDGE MOUNT SIGN STRUCTURES**  
**GENERAL PLAN AND ELEVATION**

SCALE: SHEET NO. 1 OF 4 SHEETS STA. TO STA.

F.A.I. RTE.	SECTION	COUNTY	TOTAL SHEETS	SHEET NO.
64	09-00365-01-PV	ST. CLAIR	535	265
TR RTE. 222 (RIEDER ROAD)		CONTRACT NO. 97549		ILLINOIS

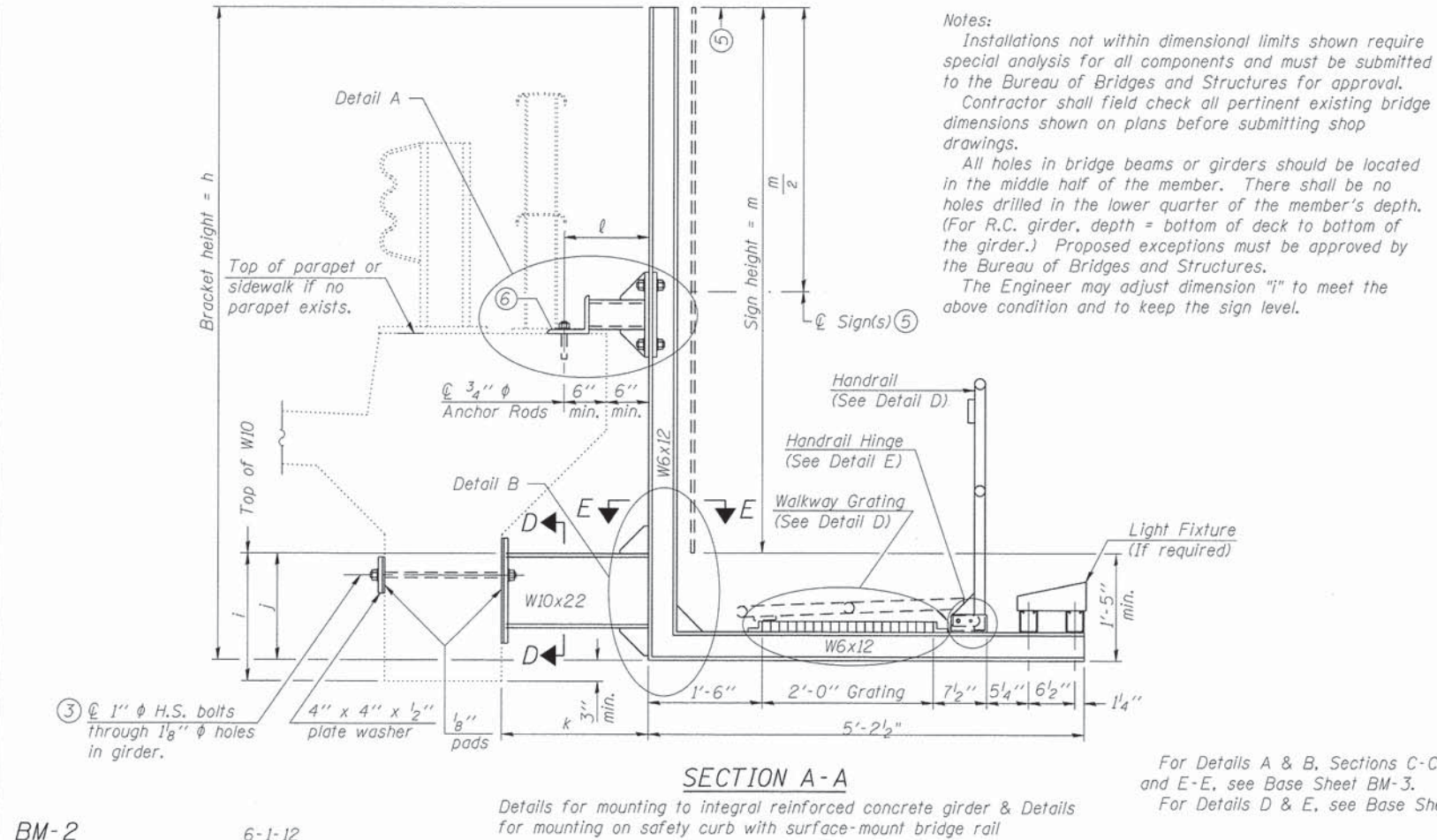
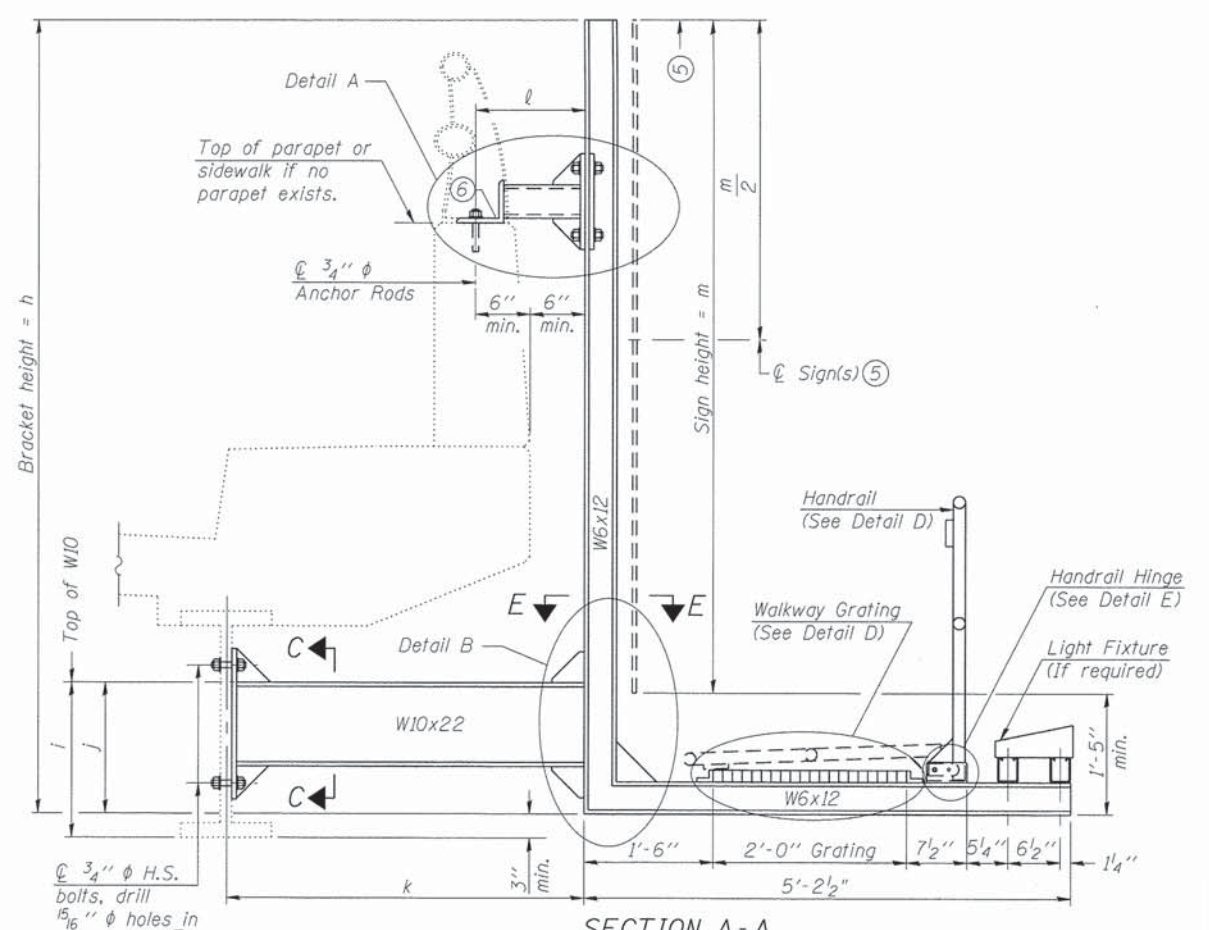
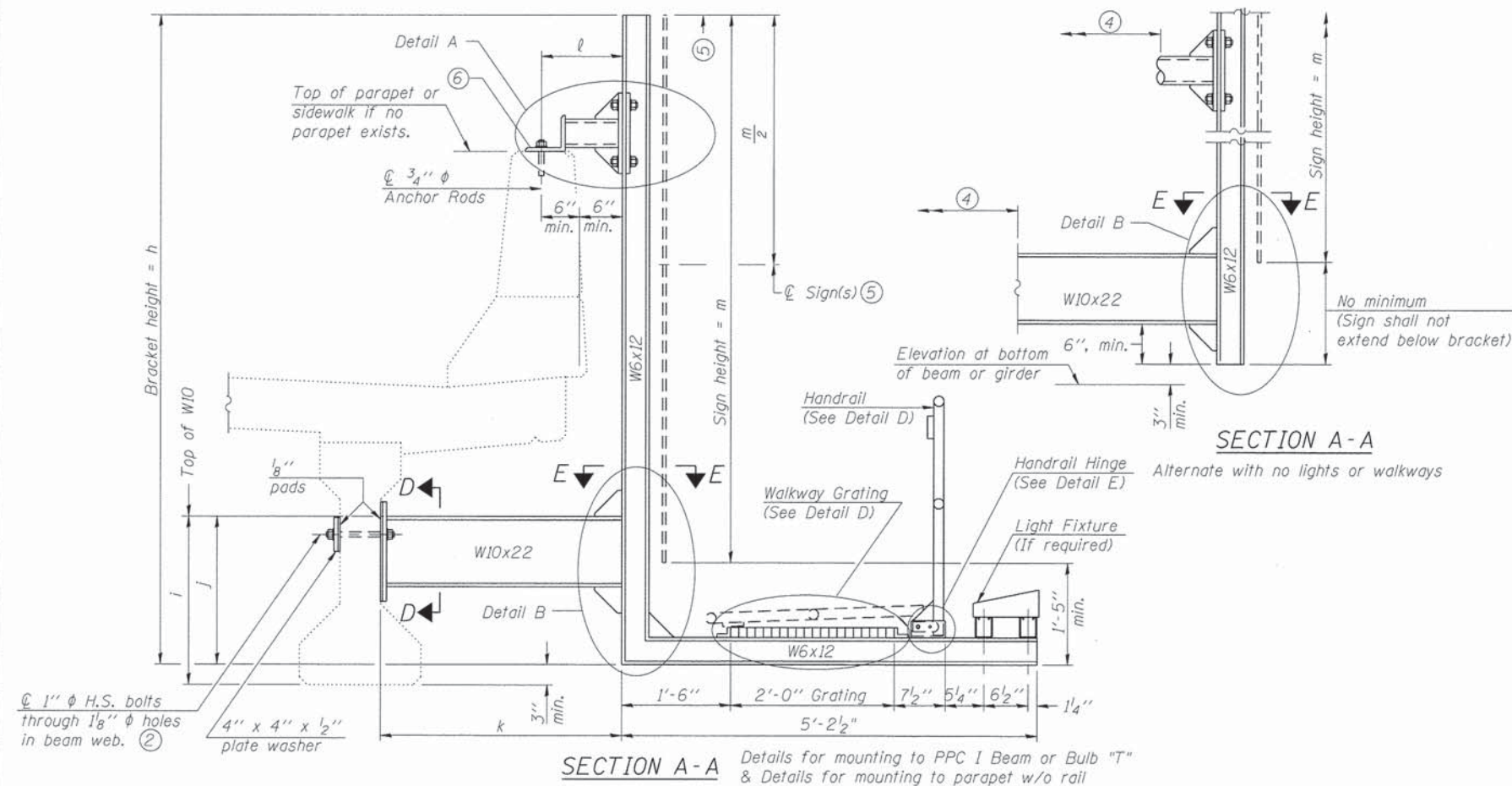

Notes:  
 Installations not within dimensional limits shown require special analysis for all components and must be submitted to the Bureau of Bridges and Structures for approval. Contractor shall field check all pertinent existing bridge dimensions shown on plans before submitting shop drawings.  
 All holes in bridge beams or girders should be located in the middle half of the member. There shall be no holes drilled in the lower quarter of the member's depth. (For R.C. girder, depth = bottom of deck to bottom of the girder.) Proposed exceptions must be approved by the Bureau of Bridges and Structures.  
 The Engineer may adjust dimension "i" to meet the above condition and to keep the sign level.

- ① Holes in new steel members may be drilled in the fabrication shop or in the field. Field drill existing members.
- ② For new PPC I beams, holes shall be formed during casting. For existing PPC I beams, prestressing strand locations shall be determined and spaced to miss strands by 6", min. Minimize spalling during field drilling of existing beams.
- ③ For new construction, form holes. For existing RC beams, locate primary reinforcement and space holes to miss by 6", min. Minimize spalling and concrete fracturing/damage during field drilling of existing concrete. Spalls over 1/4" deep or beyond the coverage of the 4x4 plate washer shall be repaired with epoxy mortar before installing washer.
- ④ For attachment details of 3 1/2" pipe and W10x22, see other sections as applicable.
- ⑤ Sign shall not extend more than 6" above top of bracket, and this dimension may vary to keep sign level if bridge is on grade or vertical curve. Multiple signs of various heights shall share a common horizontal centerline and use equal bracket heights. If no sign is attached to a W6x12 vertical (bracket only supporting walkway), dimension h shall be the same as an adjacent bracket with a sign attached, unless Engineer specifically directs shorter brackets due to locational restraints on future uses. (See Detail A for minimum bracket height.)
- ⑥ For bridge mounted sign structures installed on new bridges with railing, during design, bracket spacing must be coordinated with railing post spacing and the Contractor must install upper brackets prior to railing installation. For bridge mounted sign structures installed on existing bridges with railing, during design, brackets spacing must be coordinated with railing post spacing and the Contractor must temporarily remove sections of railing to facilitate upper bracket installation. If it is determined during design that existing railings can't be removed, alternate upper connection details must be developed for the contract plans and approved by the Bureau of Bridges and Structures.

Structure Number	Station	h	i	j	k max. (10'-0" max.)	l max. (8'-0" max.)	m (15'-0" max.)
8B0821064L020.4	997+90.18	15'-11"	2'-6"	2'-3"	4'-3"	1'-3"	14'-6"

BM-2

6-1-12

Details for mounting to integral reinforced concrete girder & Details for mounting on safety curb with surface-mount bridge rail

For Details A & B, Sections C-C, D-D and E-E, see Base Sheet BM-3.  
 For Details D & E, see Base Sheet BM-4.

FILE NAME = 09-0016-ght-signstrbm2.dgn  
 MODEL NAME = Default  
 PLOT SCALE = 12.0000 "/ft.  
 PLOT DATE = 4/26/2014

USER NAME = IOOT	DESIGNED - JAH	REVISED -
DRAWN - TJH	CHECKED - LDC	REVISED -
DATE - April 29, 2014		

STATE OF ILLINOIS  
 DEPARTMENT OF TRANSPORTATION

BRIDGE MOUNT SIGN STRUCTURES  
 WALKWAY AND CONNECTION DETAILS  
 SCALE: SHEET NO. 2 OF 4 SHEETS STA. TO STA.

F.A.I. RTE. 64	SECTION 09-00365-01-PV	COUNTY ST. CLAIR	TOTAL SHEETS 535	SHEET NO. 266
TR RTE. 222 (RIEDER ROAD)		CONTRACT NO. 97549		ILLINOIS



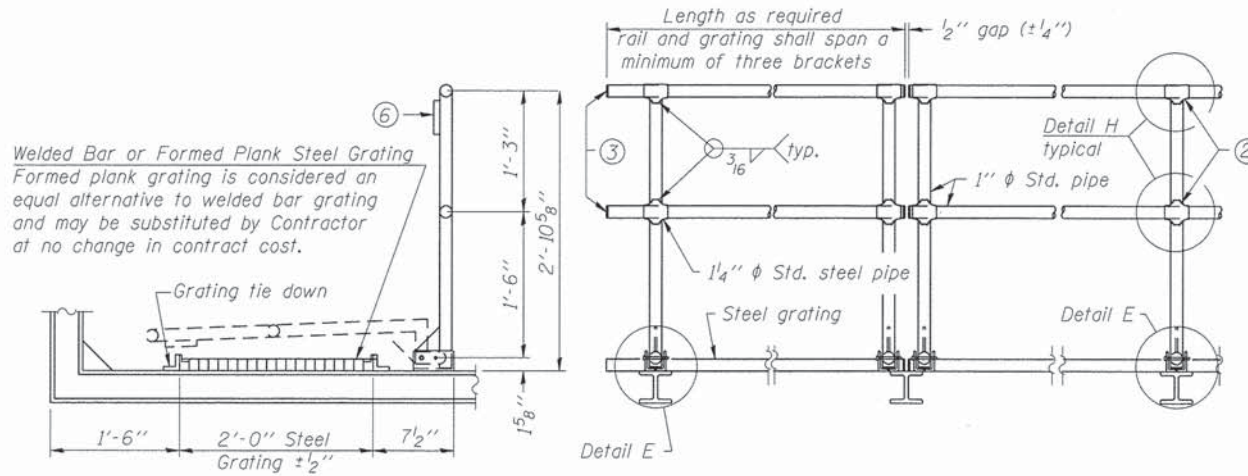

SIDE ELEVATION DETAIL D HANDRAIL FRONT ELEVATION

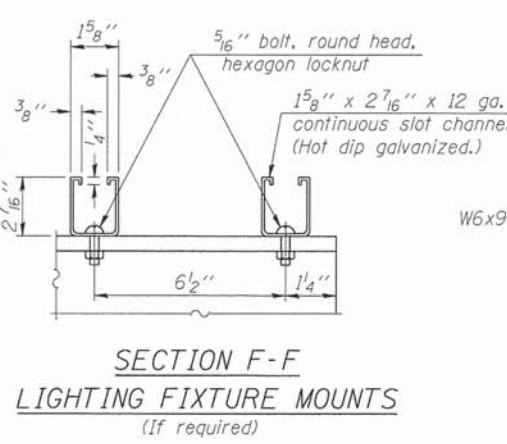

SECTION F-F LIGHTING FIXTURE MOUNTS (If required)

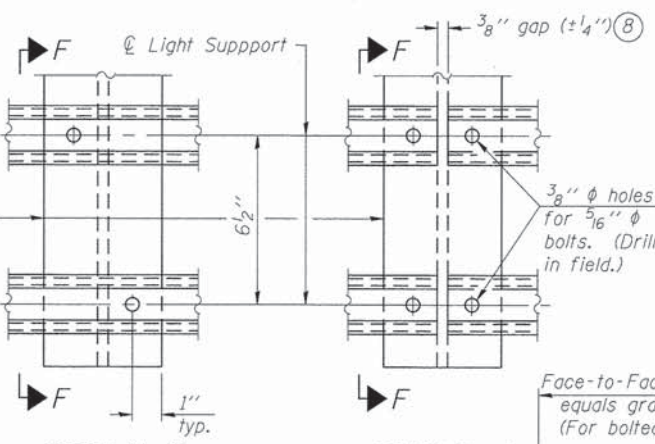

DETAIL F DETAIL G

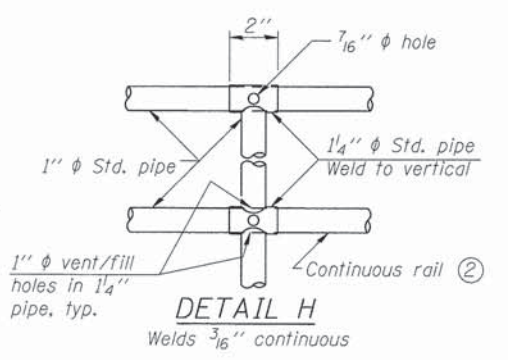

DETAIL H Welds 3/16" continuous

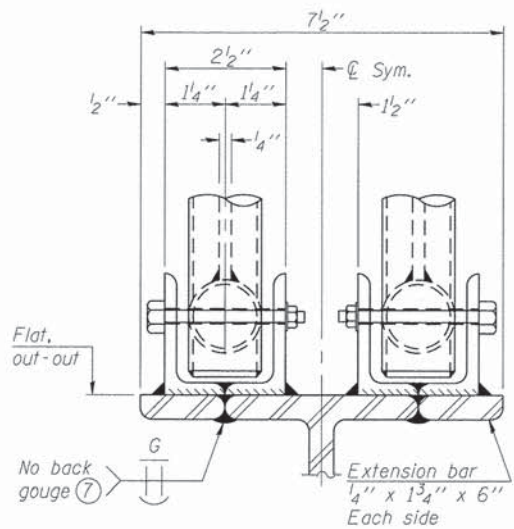

ELEVATION AT HANDRAIL JOINT (Details not shown same as "FRONT ELEVATION")

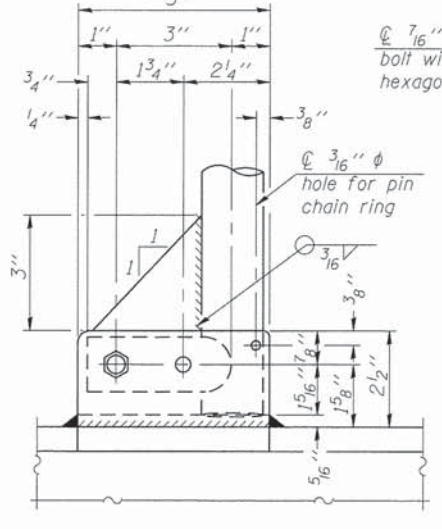

SIDE ELEVATION

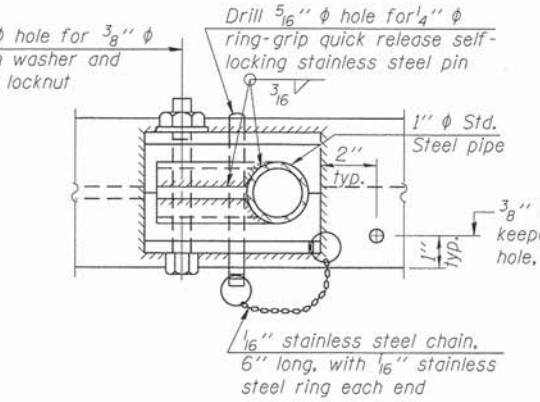

PLAN AT SINGLE HANDRAIL HINGE DETAIL E

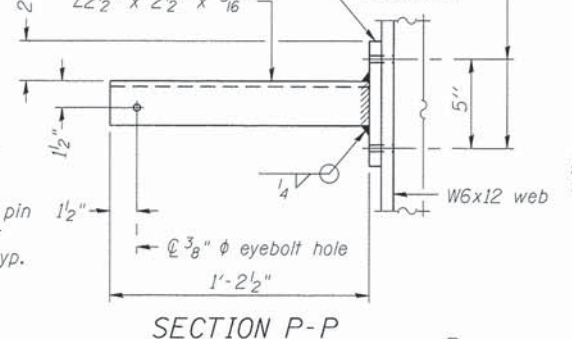

SECTION P-P

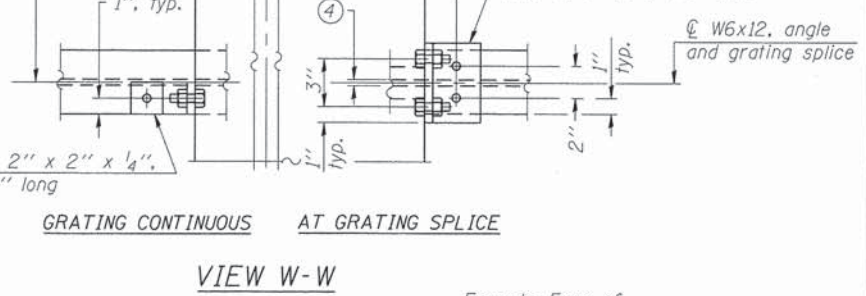

GRATING CONTINUOUS AT GRATING SPLICE

VIEW W-W

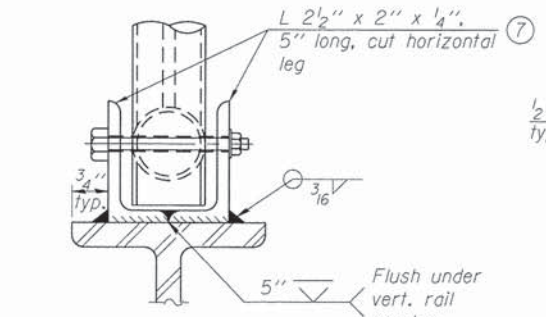

FRONT ELEVATION (See above Elevations for dimensions.)

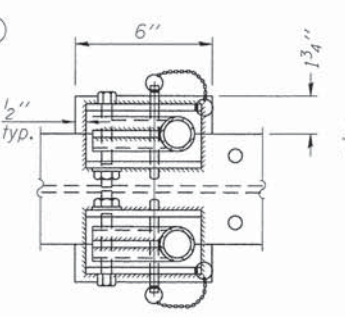

PLAN AT HANDRAIL JOINT (For Details, see Elevations.)

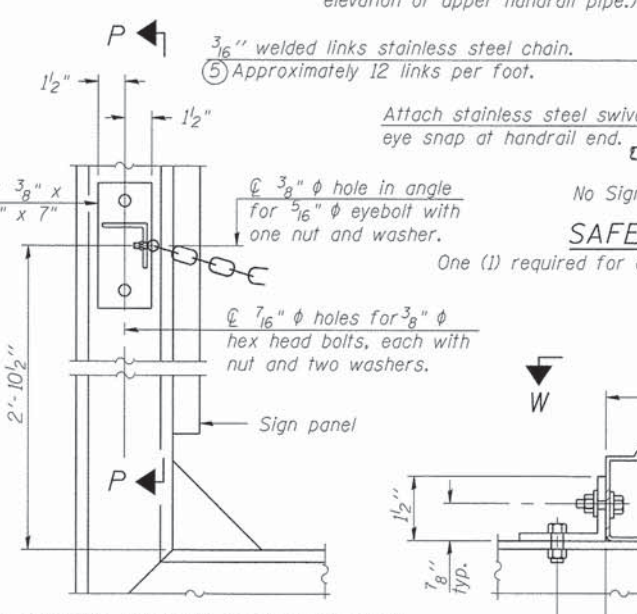

SAFETY CHAIN ATTACHMENT

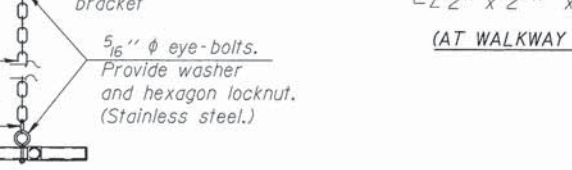

SAFETY CHAIN

One (1) required for each end of each walkway.

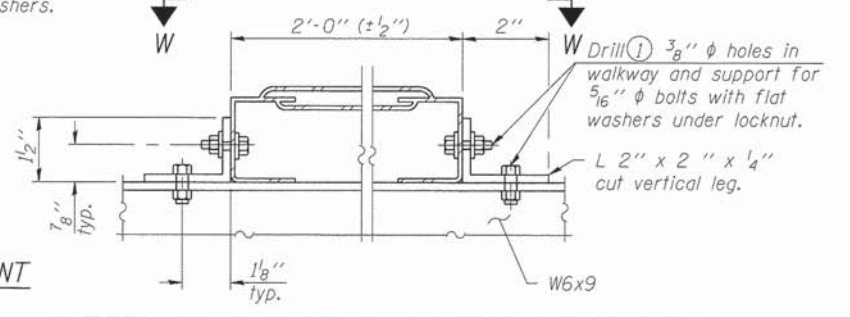

ALTERNATE FORMED PLANK GRATING DETAILS

Plank Grating: nominal depth = 2 1/2" (± 1/2"); perforated or expanded steel sheet with a non-skid surface (non-serrated) concentrated load capacity = 500 lbs. with 6'-0" clear span.

NOTES

- Drilling holes in grating may be done in shop or field, based on Contractor's preference and subject to accurate alignment. Field drilled holes must be touched up with galvanized paint.
- Horizontal rail member shall be continuous thru 1 1/4" pipe. Provide 7/16" hole in 1 1/4" pipe for 3/8" bolt. Field drill 7/16" hole in horizontal rail member. Provide washer and locknut for bolt. (Use 5/16" eyebolts in 7/16" holes on top rail at ends only.)
- Install standard force-fit end caps or weld 1/8" end plates with 1/8" c.f.w. and grind smooth. (All rail ends.)
- 3/8" (± 1/4") gap between grating panels at splice.
- Chain to be type 304L stainless steel suitable for prolonged exterior exposure. Approximately 3'-6" long chain per location. Maximum sag with handrail erected = 4".
- 1 1/8" x 1/2" x 2" welded to handrail posts to protect locations that contact grating.
- Extrusions may be used in lieu of details shown, with approval by Engineer.
- Field cut ends of light support channels shall be free of burrs or hazardous projections and coated with zinc-rich primer or equivalent.

WELDED BAR GRATING DETAILS

BM-4 6-1-12

FILE NAME = 09-0016-sht-signstrbm4.dgn	DESIGNED - JAH	REVISOR -
MODEL NAME = Default	DRAWN - TJH	REVISOR -
PLOT SCALE = 1/2" = 1'-0"	CHECKED - LDC	REVISOR -
PLOT DATE = 4/26/2014	DATE - Apr 29, 2014	REVISOR -

STATE OF ILLINOIS DEPARTMENT OF TRANSPORTATION

BRIDGE MOUNT SIGN STRUCTURES WALKWAY DETAILS

SCALE: SHEET NO. 4 OF 4 SHEETS STA. TO STA.

F.A.I. RTE.	SECTION	COUNTY	TOTAL SHEETS	SHEET NO.
64	09-00365-01-PV	ST. CLAIR	535	268
TR RTE. 222 (RIEDER ROAD)		CONTRACT NO. 97549		
ILLINOIS				

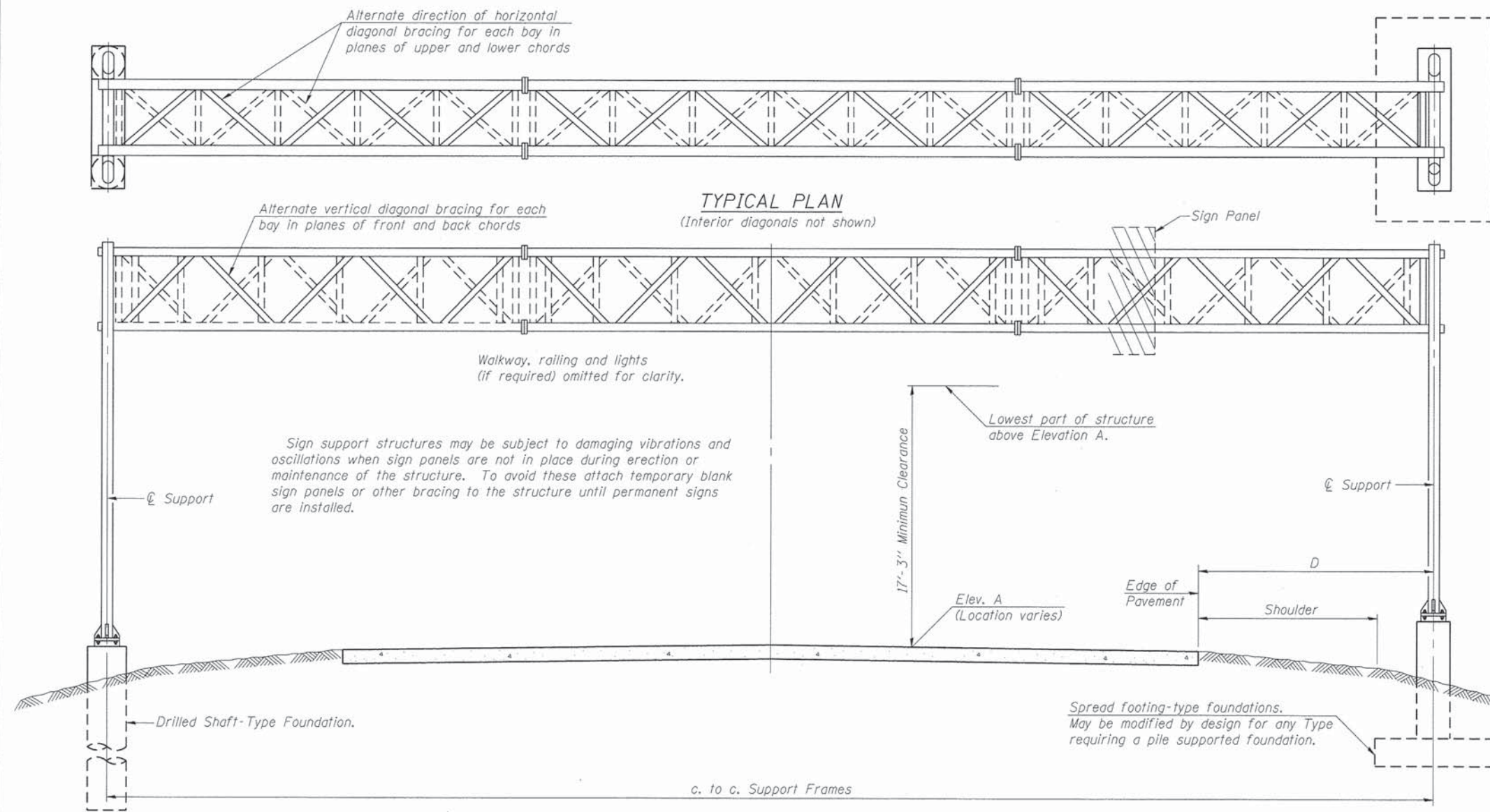

**GENERAL NOTES**

DESIGN: AASHTO Standard Specifications for Structural Supports for Highway Signs, Luminaires and Traffic Signals. ("AASHTO Specifications")

CONSTRUCTION: Current (at time of letting) Illinois Department of Transportation Standard Specifications for Road and Bridge Construction, Supplemental Specifications and Special Provisions. ("Standard Specifications")

LOADING: 90 M.P.H. WIND VELOCITY

WALKWAY LOADING: Dead load plus 500 lbs. concentrated live load.

DESIGN STRESSES:  
Field Units  
f<sub>c</sub> = 3,500 p.s.i.  
f<sub>y</sub> = 60,000 p.s.i. (reinforcement)

WELDING: All welds to be continuous unless otherwise shown. All welding to be done in accordance with current AWS D1.1 and D1.2 Structural Welding Codes (Steel and Aluminum) and the Standard Specifications.

MATERIALS: Aluminum Alloys as shown throughout plans. All Structural Steel Pipe shall be ASTM A53 Grade B or A500 Grade B or C. If A500 pipe is substituted for A53, then the outside diameter shall be as detailed and wall thickness greater than or equal to A53. All Structural Steel Plates and Shapes shall conform to AASHTO M270 Gr. 36, Gr. 50 or Gr. 50W\*. Stainless steel for shims, sleeves and handhole covers shall be ASTM A240, Type 302 or 304, or another alloy suitable for exterior exposure and acceptable to the Engineer.

The steel pipe and stiffening ribs at the base plate for the column shall have a minimum longitudinal Charpy V-Notch (CVN) energy of 15 lb.-ft. at 40° F. (Zone 2) before galvanizing.

FASTENERS FOR ALUMINUM TRUSSES: All bolts noted as "high strength" must satisfy the requirements of AASHTO M164 (ASTM A325), or approved alternate, and must have matching lock nuts. Threaded studs for splices (if Members interfere) must satisfy the requirements of ASTM A449, ASTM A193, Grade B7, or approved alternate, and must have matching lock nuts. Bolts and lock nuts not required to be high strength must satisfy the requirements of ASTM A307. All bolts and lock nuts must be hot dip galvanized per AASHTO M232. The lock nuts must have nylon or steel inserts. A stainless steel flat washer conforming to ASTM A240 Type 302 or 304, is required under both head and nut or under both nuts where threaded studs are used. High strength bolt installation shall conform to Article 505.04 (f) (2)d of the IDOT Standard Specifications for Road and Bridge Construction. Rotational capacity ("ROCAP") testing of bolts will not be required.

U-BOLTS AND EYEBOLTS: U-Bolts and Eyebolts must be produced from ASTM A276 Type 304, 304L, 316 or 316L, Condition A, cold finished stainless steel, or an equivalent material acceptable to the Engineer. All nuts for U-Bolts and Eyebolts must be lock nuts equivalent to ASTM A307 with nylon or steel inserts and hot dip galvanized per AASHTO M232. A stainless steel flat washer conforming to ASTM A240, Type 302 or 304, is required under each U-Bolt and Eyebolt lock nut.

GALVANIZING: All Steel Grating, Plates, Shapes and Pipe shall be Hot Dip Galvanized after fabrication in accordance with AASHTO M111. Painting is not permitted.

ANCHOR RODS: Shall conform to ASTM F1554 Gr. 105.

CONCRETE SURFACES: All concrete surfaces above an elevation 6" below the lowest final ground line at each foundation shall be cleaned and coated with Bridge Seat Sealer in accordance with the Standard Specifications.

REINFORCEMENT BARS: Reinforcement Bars designated (E) shall be epoxy coated in accordance with the Standard Specifications.

FOUNDATIONS: The contract unit price for Concrete Foundations and Drilled Shaft Concrete Foundations shall include reinforcement bars complete in place.

**TYPICAL ELEVATION**  
(Looking at Face of Signs)\*\*

Structure Number	Station	Design Truss Type	c. to c. Supports	Elev. A	Dim. D	Height of Tallest Sign	Total Sign Area
BS0821064R018.4	894+56	II-A	104'-0"	526.43	32'-10"	12'-0"	496
BS0821064L019.1	931+02	II-A	106'-0"	491.00	32'-11 1/2"	12'-0"	543

\*\*Looking upstation for structures with signs both sides.

\* If M270 Gr. 50W (M222) steel is proposed, chemistry for plate to be used shall first be approved by the Engineer as suitable for galvanizing and welding.

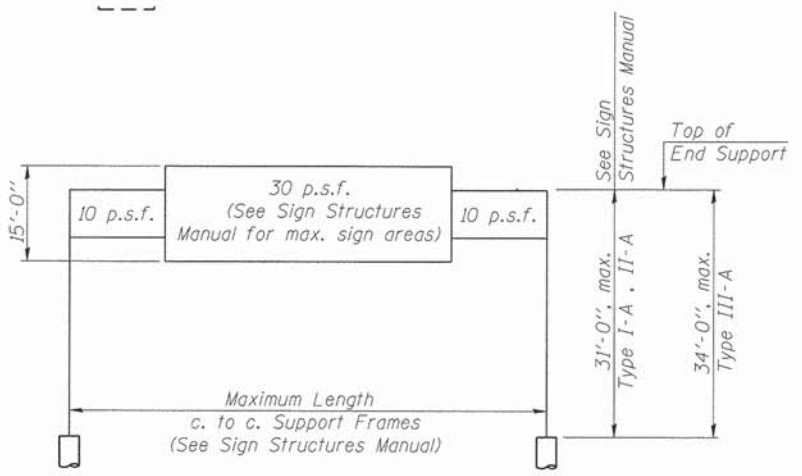

**DESIGN WIND LOADING DIAGRAM**

Parameters shown are basis for I.D.O.T. Standards and Sign Manual Tables. Installations not within dimensional limits shown require special analysis for all components.

**TOTAL BILL OF MATERIAL**

ITEM	UNIT	TOTAL
OVERHEAD SIGN STRUCTURE SPAN TYPE II-A	Foot	210.0
OVERHEAD SIGN STRUCTURE WALKWAY TYPE A	Foot	119.0
DRILLED SHAFT CONCRETE FOUNDATIONS	Cu. Yds.	62.1

05-A-1

6-1-12

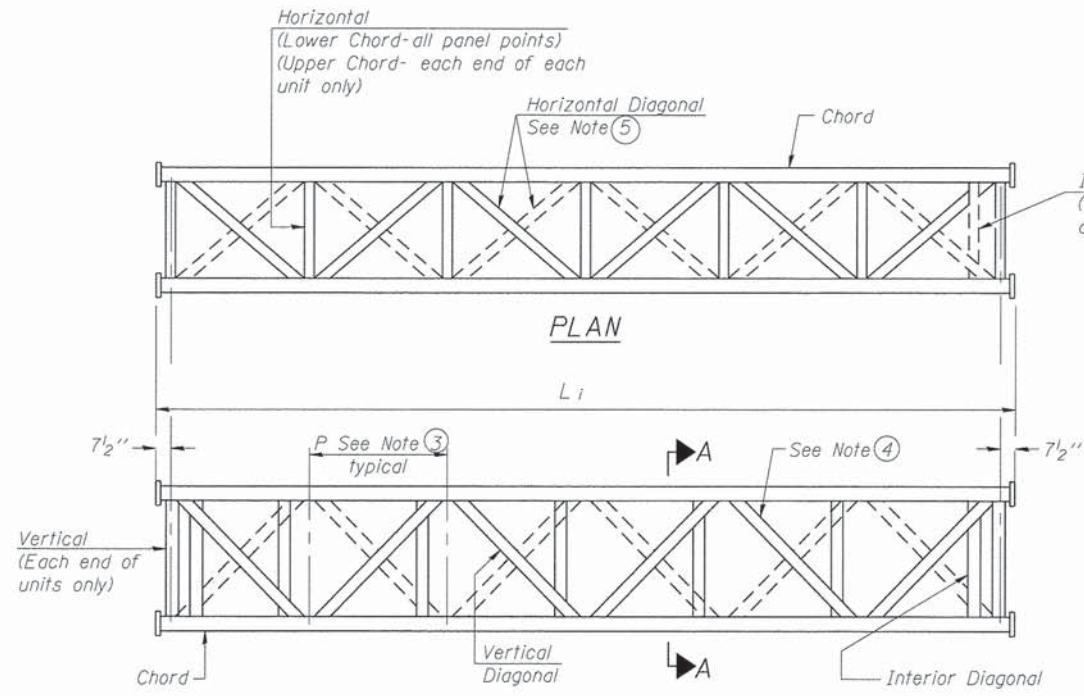

**ELEVATION  
TYPICAL INTERIOR UNIT**  
Even number of panels/interior unit required.

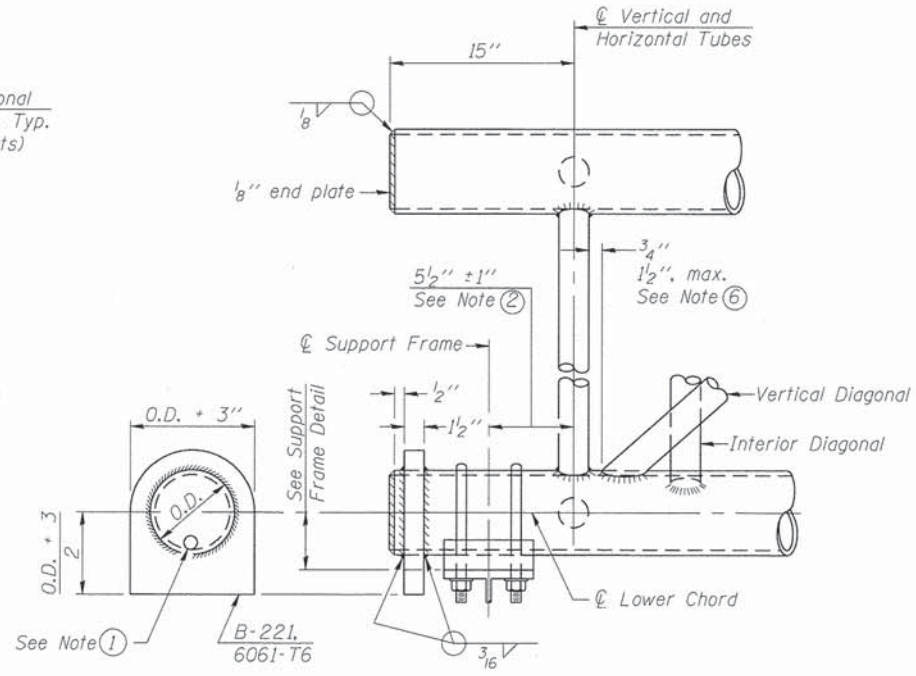

**SUPPORT END DETAIL FOR EXTERIOR UNIT**

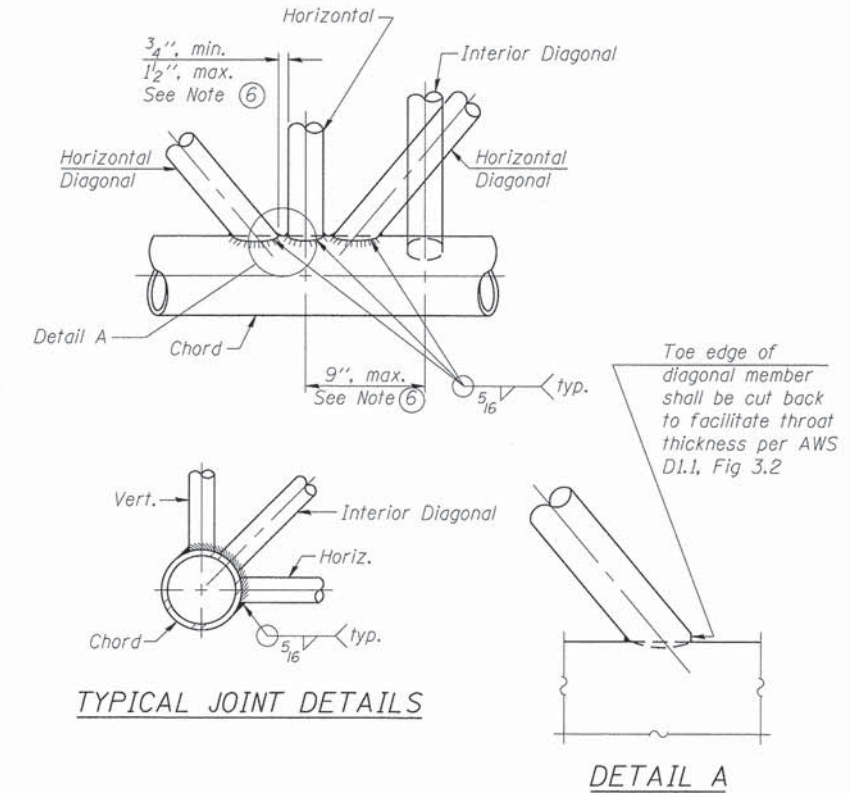

**TYPICAL JOINT DETAILS**

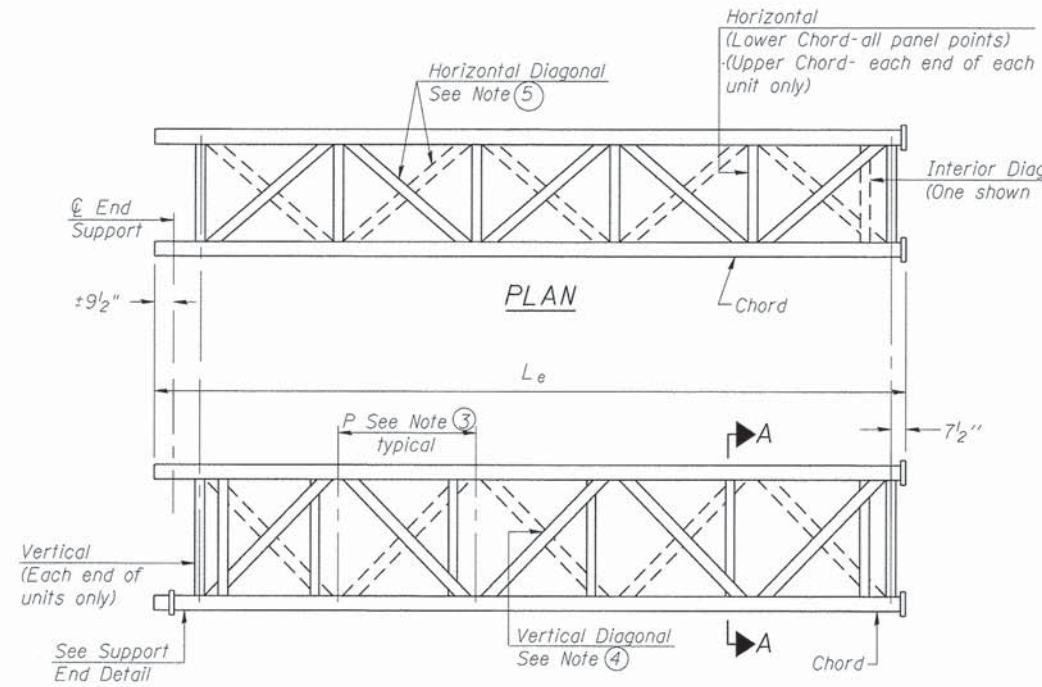

**ELEVATION  
TYPICAL EXTERIOR UNIT**  
Even or odd number of panels/exterior units allowed.

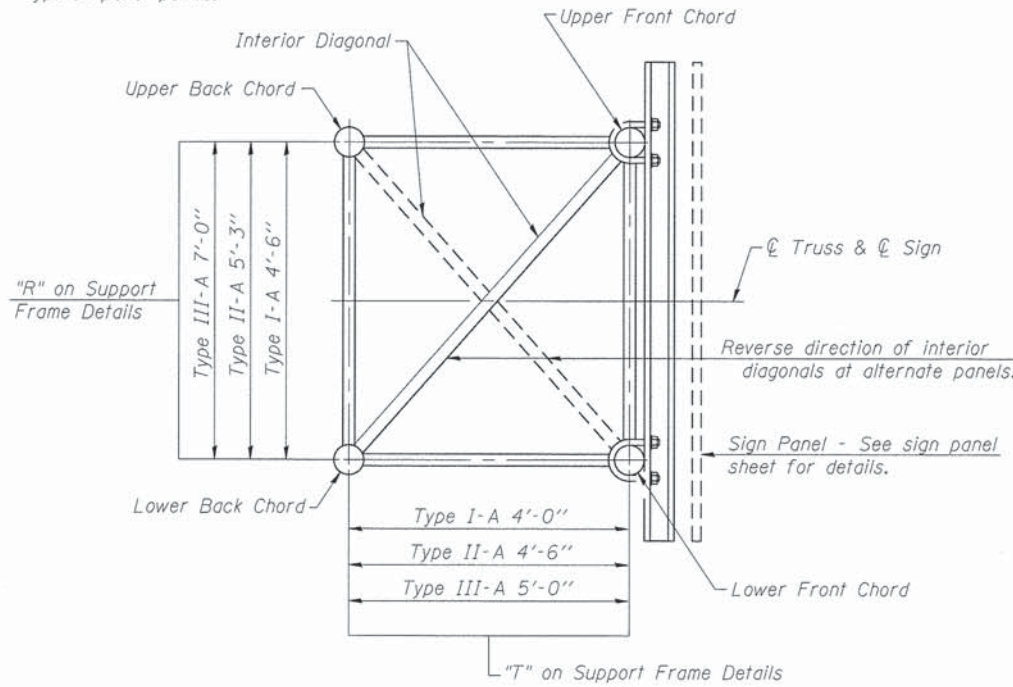

**SECTION A-A**

- ① Contractor may alternatively use standard aluminum drive-fit cap to close end. 1/2"  $\phi$  drain hole in end plate/drive-fit cap. (Typ. at ends of all chords)
- ② 5 1/2" end dimension may vary by  $\pm 1"$  to provide uniform panel spacing (P).
- ③ Panel spacing (P) shall be uniform for entire truss and between 4'-0" and 5'-0" for Type I-A or 4'-0" and 5'-6" for Types II-A and III-A.
- ④ Vertical Diagonals in front and back face shall alternate.
- ⑤ Hidden lines show wind bracing alternates direction between planes of top and bottom chords.
- ⑥ All diagonals shall be detailed for minimum offset from the panel point based on the following: Offset shall be such as to provide a 3/4" minimum to 1 1/2" maximum clearance between any diagonal and any horizontal or vertical member, and to provide clearance for U-bolt connections of signs or walkway brackets.

P:\05-2016\05-2016-Phase 1\1\B\_CAD\CADD\_Sheets\09-2016-sht-signovr-hd02.dgn

OS-A-2

6-1-12

FILE NAME = 09-2016-sht-signovr-hd02.dgn	USER NAME = IDOT	DESIGNED - JAH	REVISED -
MODEL NAME = Default	DRAWN - TJH	REVISOR -	REVISOR -
PLOT SCALE = 1:8000' / 1/8"	CHECKED - LOC	REVISOR -	REVISOR -
PLOT DATE = 4/26/2014	DATE - Apr 29, 2014	REVISOR -	REVISOR -

**STATE OF ILLINOIS  
DEPARTMENT OF TRANSPORTATION**

**OVERHEAD SIGN STRUCTURES - ALUMINUM TRUSS  
DETAILS FOR TRUSS TYPES I-A, II-A AND III-A**

SCALE: SHEET NO. 2 OF 11 SHEETS STA. TO STA.

F.A.I. RTE.	SECTION	COUNTY	TOTAL SHEETS	SHEET NO.
64	09-00365-01-PV	ST. CLAIR	535	270
TR RTE. 222 (RIEDER ROAD)		CONTRACT NO. 97549		ILLINOIS

TRUSS UNIT TABLE

Structure Number	Station	Design Truss Type	Exterior Units (2)			Interior Unit				Upper & Lower Chord		Verticals; Horizontals; Vertical, Horizontal, and Interior Diagonals				Camber at Midspan	Splicing Flange					
			No. Panels per Unit	Unit Lgth.(L <sub>e</sub> )	Panel Lgth.(P)	No. Req'd.	No. Panels per Unit	Unit Lgth.(L <sub>i</sub> )	Panel Lgth.(P)	O.D.	Wall	O.D.	Wall	Bolts			Weld Sizes		A	B		
														No./Splice	Dia.		W	W <sub>1</sub>				
8S0821064R018.4	894+56	II-A	7	37'-0 1/4"	5'-0 1/4"	1	6	31'-4 1/2"	5'-0 1/4"	6 1/2"	5/16"	3"	5/16"	3 1/2"	6	1"	3/8"	1/4"	11"	14 1/2"		
8S0821064L019.1	931+02	II-A	7	37'-9"	5'-1 1/2"	1	6	32'-0"	5'-1 1/2"	6 1/2"	5/16"	3"	5/16"	3 1/2"	6	1"	3/8"	1/4"	11"	14 1/2"		

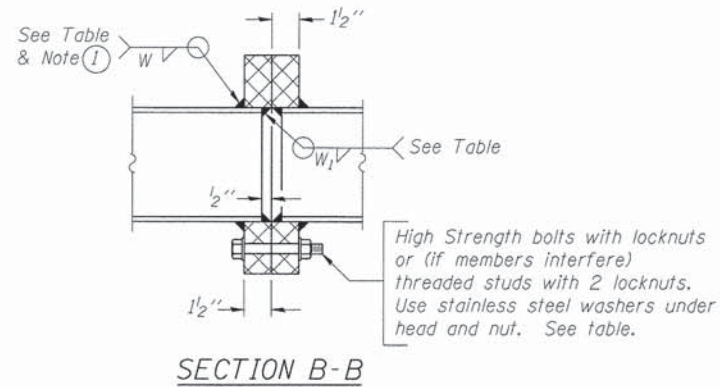

(1) Splicing Flanges shall be attached to each truss unit with the truss shop assembled to camber shown. Truss units shall be in proper alignment and flange surfaces shall be shop bolted into full contact before welding. Sufficient external welds or tacks shall be made to secure flanges until remaining welds are made after disassembly. Adjacent flanges shall be "match marked" to insure proper field assembly.

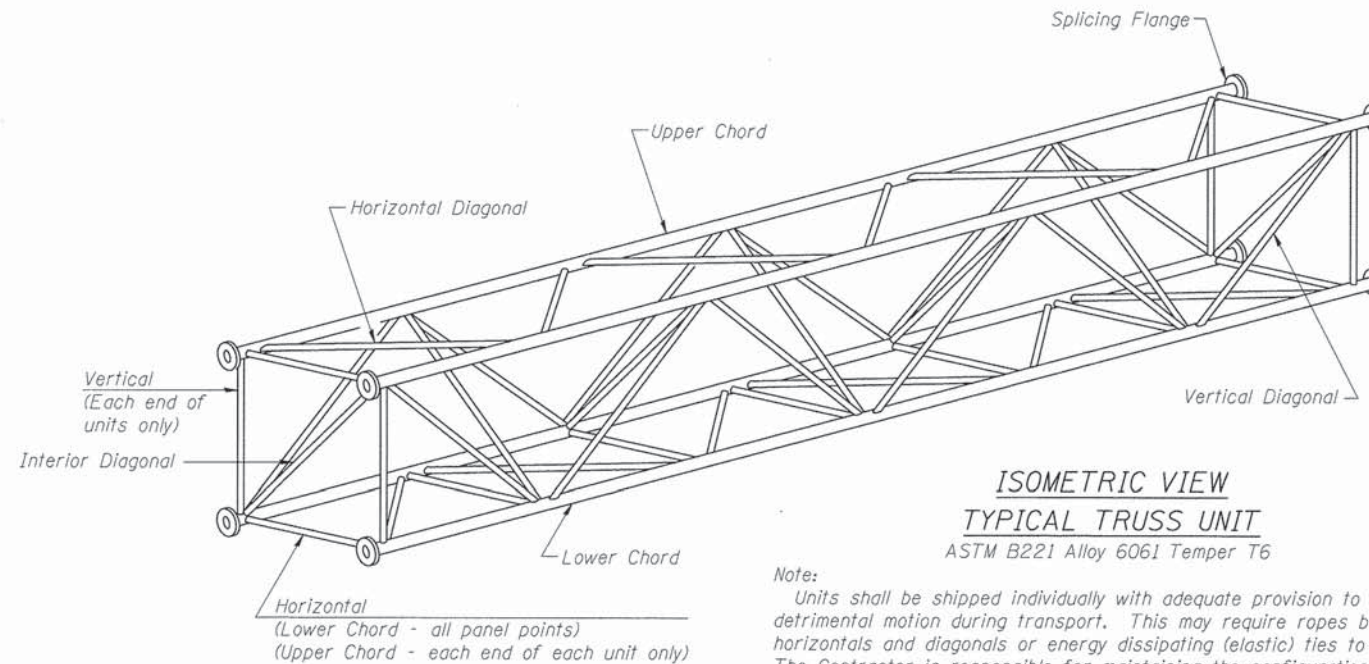

Note: Units shall be shipped individually with adequate provision to prevent detrimental motion during transport. This may require ropes between horizontals and diagonals or energy dissipating (elastic) ties to the vehicle. The Contractor is responsible for maintaining the configuration and protection of the units.

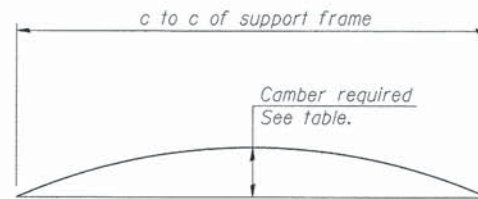

CAMBER DIAGRAM  
Camber curve shown is theoretical. Actual camber attained by slope changes at splices between units.

CAMBER ATTAINMENT EXAMPLES:

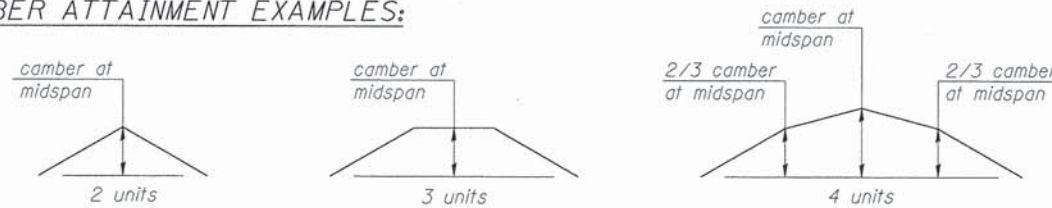

Camber shown is for fabrication only, measured with truss fully supported. (No-load condition)

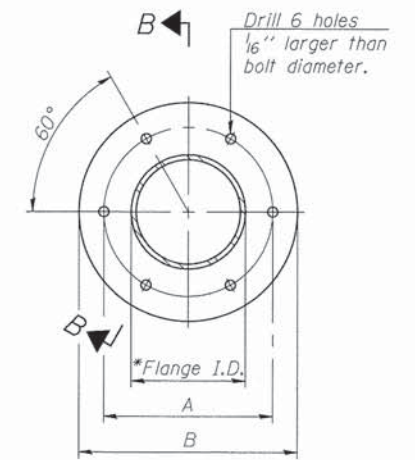

TRUSS TYPES I-A, II-A, & III-A

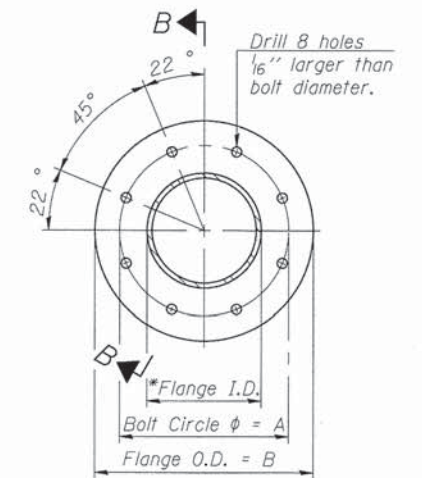

TRUSS TYPES II-A & III-A  
SPlicing FLANGES

ASTM B221, Alloy 6061-T6  
or ASTM B209, Alloy 6061-T651  
\*To fit O.D. of Chord with maximum gap of 1/16".

OS4-A-2

6-1-12

FILE NAME = 09-0016-shtr-signovrh03.dgn	USER NAME = IDOT	DESIGNED - JAH	REVISED -
MODEL NAME = Default	DRAWN - TJH	CHECKED - LDC	REVISED -
PLOT SCALE = 1:8000 1/16"	DATE - Apr 29, 2014	REVISED -	REVISED -

STATE OF ILLINOIS  
DEPARTMENT OF TRANSPORTATION

OVERHEAD SIGN STRUCTURES - ALUMINUM TRUSS DETAILS  
FOR TRUSS TYPES I-A, II-A AND III-A

SCALE: SHEET NO. 3 OF 11 SHEETS STA. TO STA.

F.A.I. RTE.	SECTION	COUNTY	TOTAL SHEETS	SHEET NO.
64	09-00365-01-PV	ST. CLAIR	535	271
TR RTE. 222 (RIEDER ROAD)			CONTRACT NO. 97549	
ILLINOIS				

F:\09-0016\02\_Rieder\_Road\_Phase\_II\IB\_CADD\ADD\_Sheets\09-0016-shtr-signovrh03.dgn

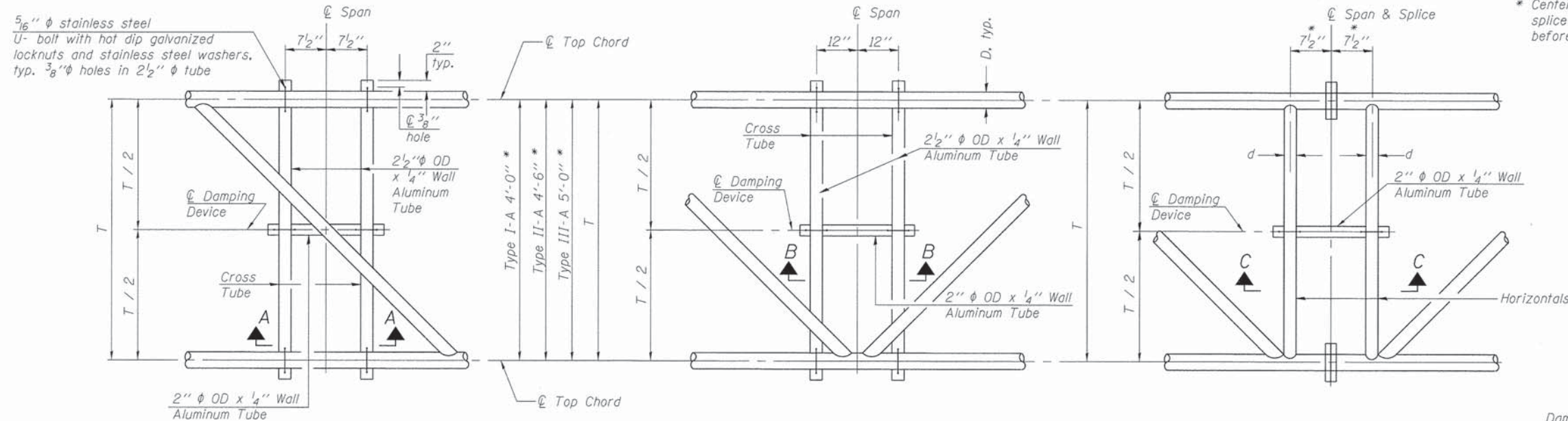

\* Center of horizontal to center of splice dimension may vary. Verify before drilling holes in mounting tube.

PLAN DETAIL "A"  
Span between Panel Points

PLAN DETAIL "B"  
Span at Panel Point

PLAN DETAIL "C"  
Span at Chord Splice

NOTES

Damper: One damper per truss. (31 lbs. minimum Stockbridge-Type Aluminum - 29" minimum between ends of weights) Cost included in Overhead Sign Structure...

Materials: Materials: Aluminum tubes shall be ASTM B221 alloy 6061 temper T6. Cost included in Overhead Sign Structure...

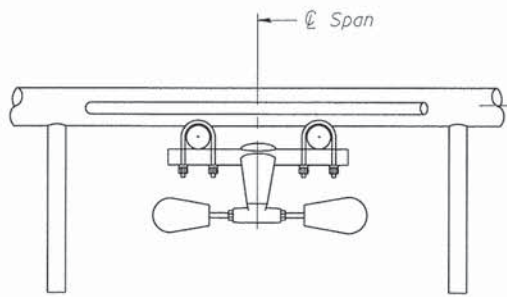

SECTION A-A

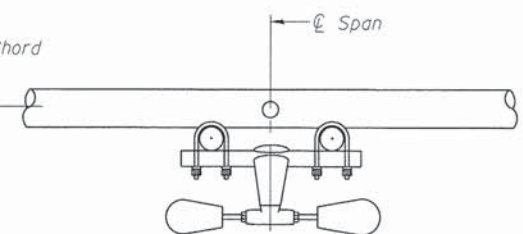

SECTION B-B

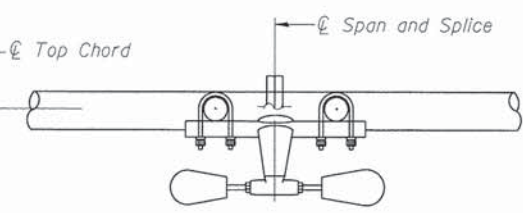

SECTION C-C

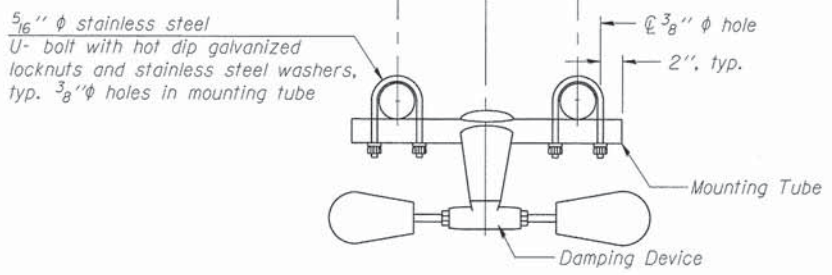

TRUSS DAMPING DEVICE CONNECTION DETAIL  
(Typical)

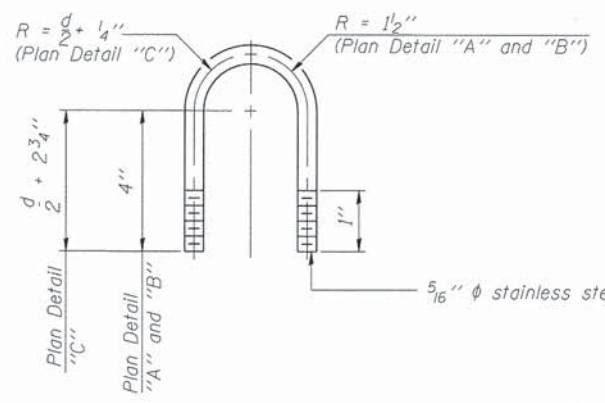

DAMPING DEVICE MOUNTING TUBE U-BOLT DETAIL  
(Typical)

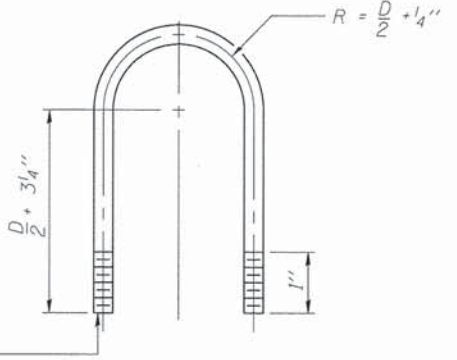

TOP CHORD TO CROSS TUBE U-BOLT DETAIL  
(Typical - Detail "A" and "B")

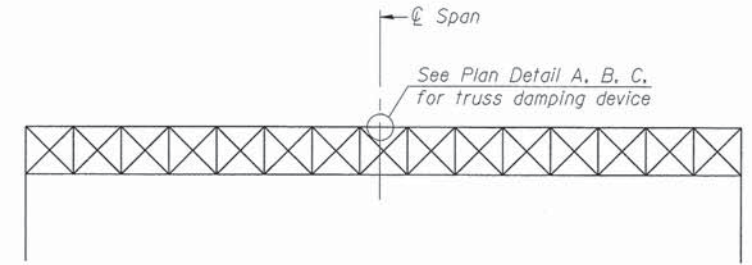

ELEVATION  
Aluminum Overhead Sign Truss

F:\gpr-0016.dwg Redline Road Phase 1\118 CAD\CADD Sheets\09-0016-shr-signovrhd04.dgn

OS-A-D

6-1-12

FILE NAME = 09-0016-shr-signovrhd04.dgn	USER NAME = IDOT	DESIGNED - JAH	REVISED -
MODEL NAME = Default	DRAWN - TJH	CHECKED - LDC	REVISED -
PLOT SCALE = 1:8000 1/16"	DATE - April 29, 2014		
PLOT DATE = 4/26/2014			

STATE OF ILLINOIS  
DEPARTMENT OF TRANSPORTATION

OVERHEAD SIGN STRUCTURE  
DAMPING DEVICE

SCALE: SHEET NO. 4 OF 11 SHEETS STA. TO STA.

F.A.I. RTE.	SECTION	COUNTY	TOTAL SHEETS	SHEET NO.
64	09-00365-01-PV	ST. CLAIR	535	272
TR RTE. 222 (RIEDER ROAD)			CONTRACT NO. 97549	
ILLINOIS				



3/4" φ stainless steel U-bolt.  
Provide two washers and two hexagon locknuts. (4)  
1 1/16" x 2" slots on 10" φ pipe.  
(4 slots required per pipe)

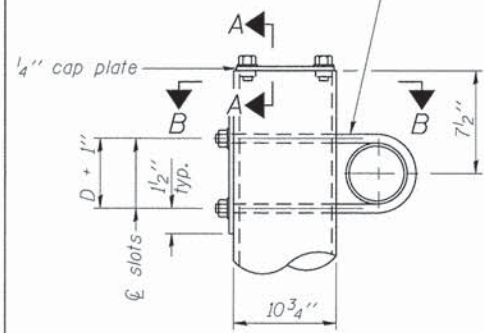

DETAIL A

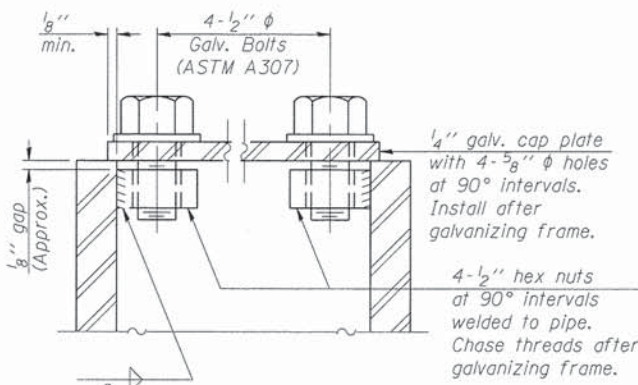

SECTION A-A

As an alternate to bolts, may use galvanized drive-fit caps installed after galvanizing frame.

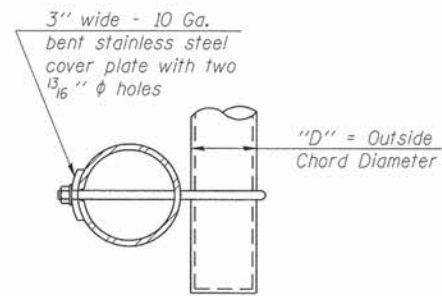

SECTION B-B

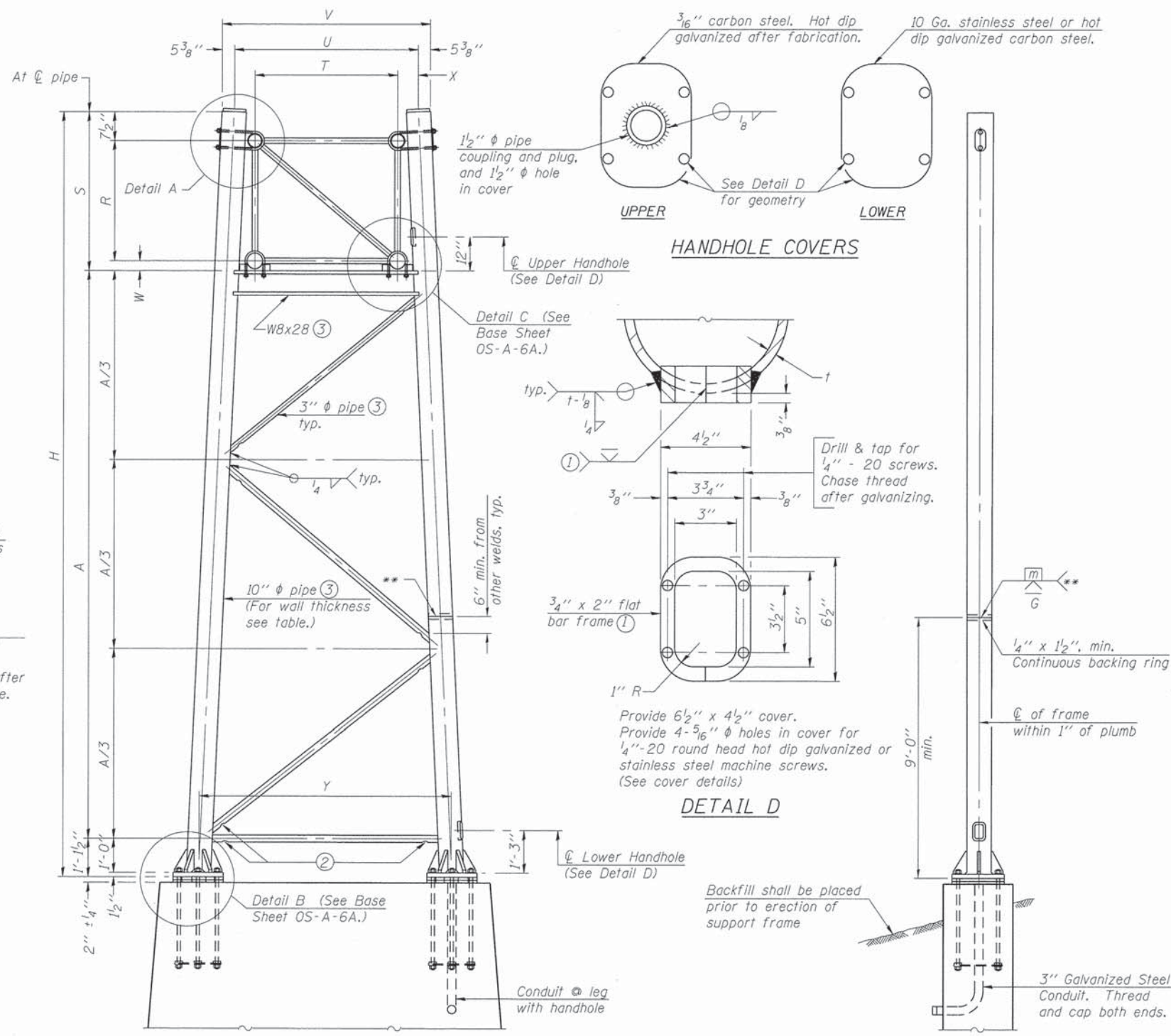

For Foundation Details, see base sheet OS-F3 (Spread Footing) or OS4-F3 (Drilled Shaft).

SIDE ELEVATION

10" φ PIPE TRUSS SUPPORT FRAME

\*\* One butt welded joint is allowed only on one post per support frame. If used, weld procedure must be pre-approved by Engineer and joint shall receive 100% RT or UT (tension criteria) at Contractor's expense.

Truss Type	Dimensions							
	R	S	T	U	V	W	X	Y
I-A	4'-6"	5'-5 1/2"	4'-0"	5'-6"	6'-4 3/4"	4"	9"	8'-3"
II-A (5)	5'-3"	6'-3 3/4"	4'-6"	6'-1"	6'-11 3/4"	4 3/4"	9 1/2"	8'-3"

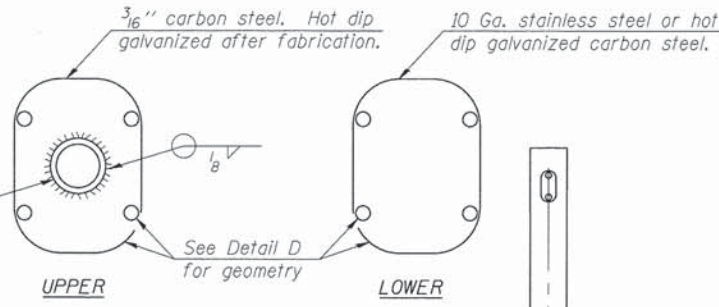

HANDHOLE COVERS

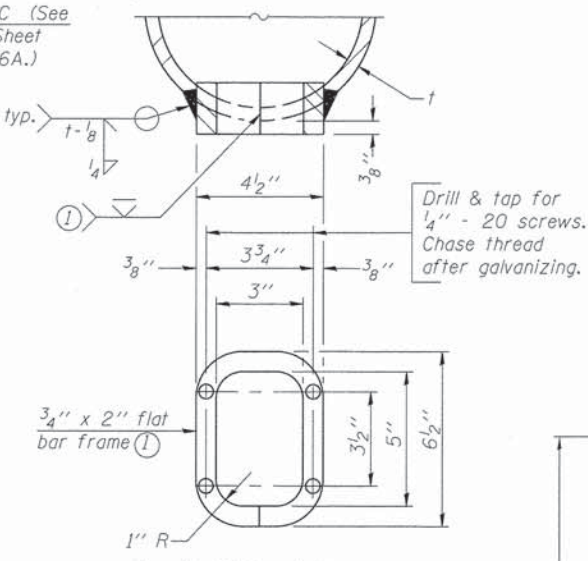

DETAIL D

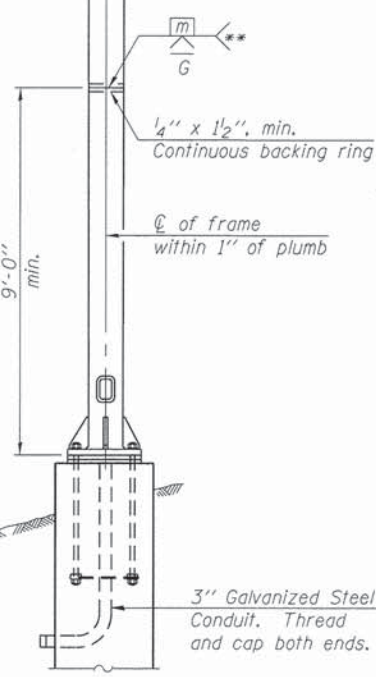

END ELEVATION

Support Design Loads: See Base Sheet OS-A-1 for design and loading criteria.  
Load combinations checked include deadload plus:  
a) 100% wind normal to sign, 20% parallel to sign  
b) 60% wind normal to sign, 30% parallel to sign

- In lieu of fabricated handhole frame as shown, may cut from 2" plate (rolling direction vertical). All cut faces to be ground to ANSI Roughness of 500 μin or less.
- Galvanizing vent holes of adequate size shall be provided on underside at each end of bracing pipes. Alternately, holes may be drilled in wall of pipe column. All vent holes shall be drilled and de-burred, typ.
- Steel pipe, plate, carbon steel handhole covers and rolled sections shall be hot dip galvanized after fabrication. Painting is not permitted. See Base Sheet OS-A-1.
- See General Notes for fasteners.
- Dimensions shown are based on selection criteria in the Sign Structures Manual. Nonstandard applications must have dimensions verified or amended as appropriate.
- "H" based on 15'-0" or actual sign height, whichever is greater.

Structure Number	Station	Support		Truss Type	Pipe Wall Thickness	H (6)	A
		Left	Right				
8S0821064R018.4	894+56		X	II-A	0.500	32'-6"	25'-1 1/4"
8S0821064R018.4	894+56	X		II-A	0.365	25'-10"	18'-5 1/4"
8S0821064L019.1	931+02		X	II-A	0.365	26'-5"	19'-0 1/4"
8S0821064L019.1	931+02	X		II-A	0.500	32'-8"	25'-3 1/4"

OS-A-6

6-1-12

FILE NAME = 09-0016-shft-signovrh05.dgn	USER NAME = IDOT	DESIGNED - JAH	REVISED -
MODEL NAME = Default	DRAWN - TJH	CHECKED - LDC	REVISED -
PLOT SCALE = 1:8000 1/2" = 1'	DATE - Apr 29, 2014		
PLOT DATE = 4/26/2014			

STATE OF ILLINOIS  
DEPARTMENT OF TRANSPORTATION

OVERHEAD SIGN STRUCTURES  
SUPPORT FRAME FOR ALUMINUM TRUSS

SCALE: SHEET NO. 5 OF 11 SHEETS STA. TO STA.

F.A.I. RTE. 64	SECTION 09-00365-01-PV	COUNTY ST. CLAIR	TOTAL SHEETS 535	SHEET NO. 273
TR RTE. 222 (RIEDER ROAD)			CONTRACT NO. 97549	
ILLINOIS				

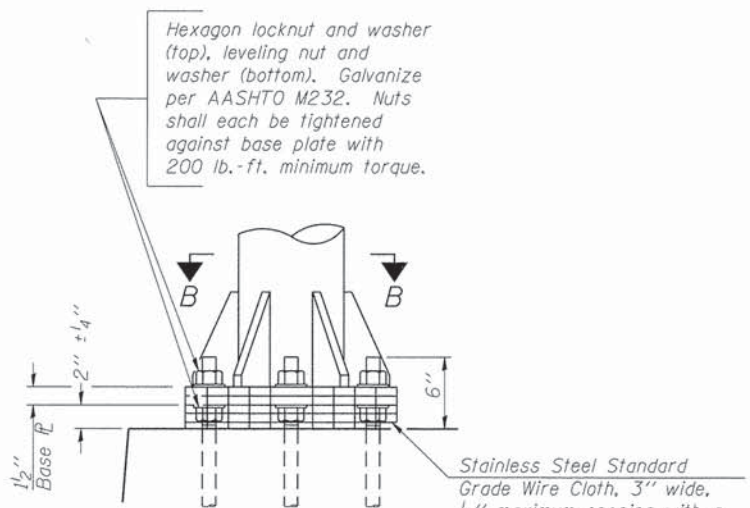

**DETAIL B**

Ribs shall be cut to fit slope of pipe.

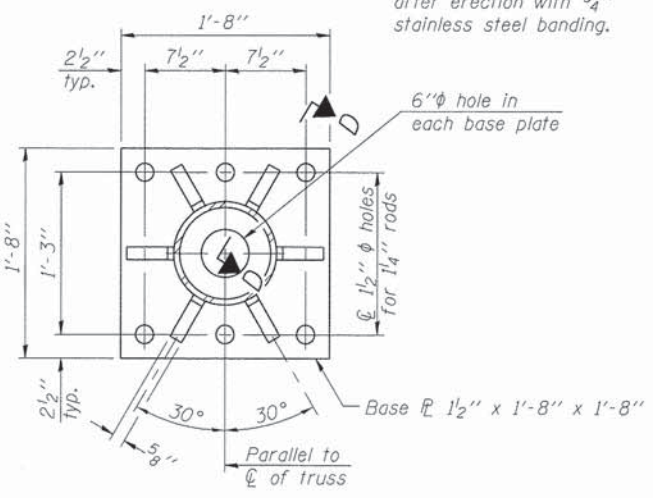

**SECTION B-B**

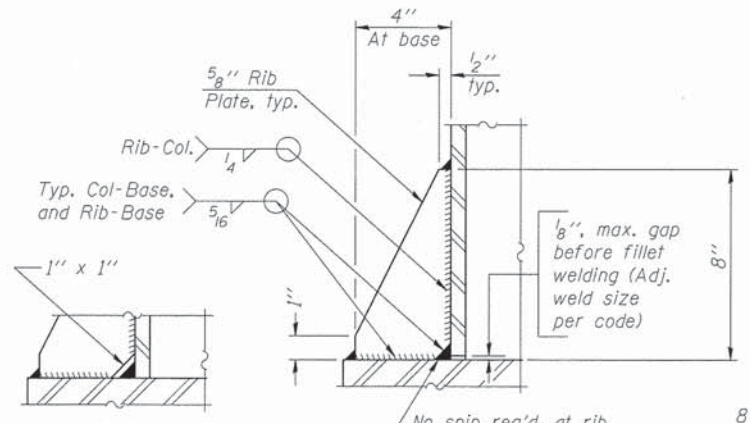

**SECTION D-D**

\*\* Alternate detail if welding col. to base plate first, then snip inside corner of ribs. Terminate weld on rib 1/4" from snip.

No snip req'd. at rib inside corner if placed before col. to base plate welding.\*\*

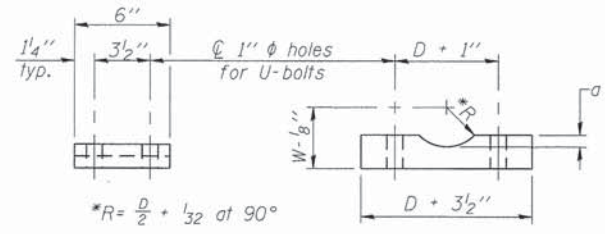

**SADDLE SHIM DETAIL**

ASTM B26 Alloy 356-F  
or  
ASTM B209 Alloy 6061-T651  
(4 required per sign truss)

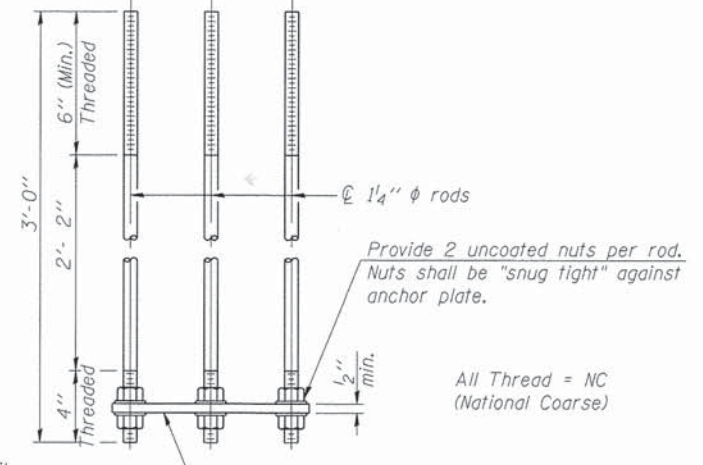
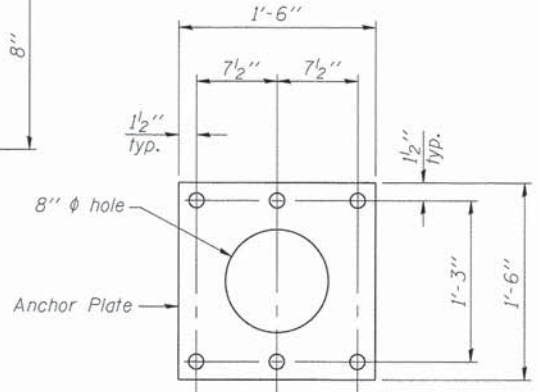

**ANCHOR ROD DETAIL**  
Spread Footing Foundation

Anchor rods shall conform to ASTM F1554 Grade 105. Galvanize upper 12" minimum per AASHTO M232. No welding shall be permitted on rods.

**10"  $\phi$  PIPE SUPPORT FRAME DETAILS**

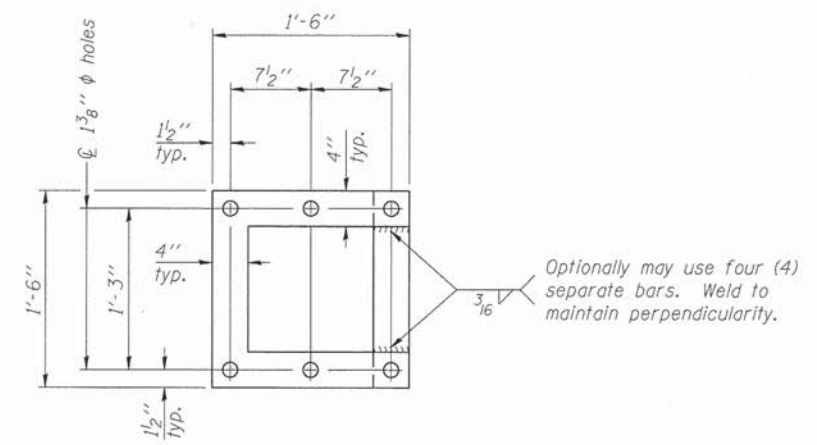

**POSITIONING PLATE(S)**

At each location, provide 1/4" thick positioning plate(s) and six (6) additional nuts to be used with leveling nuts to maintain anchor bolts position during concrete placement.

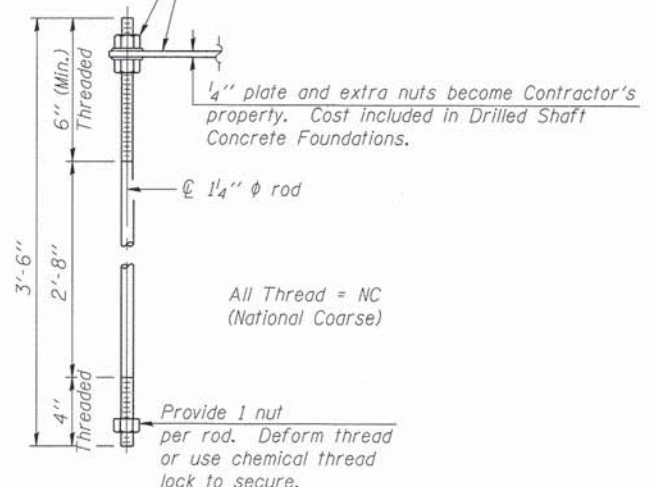

**ANCHOR ROD DETAIL**  
Drilled Shaft Foundation

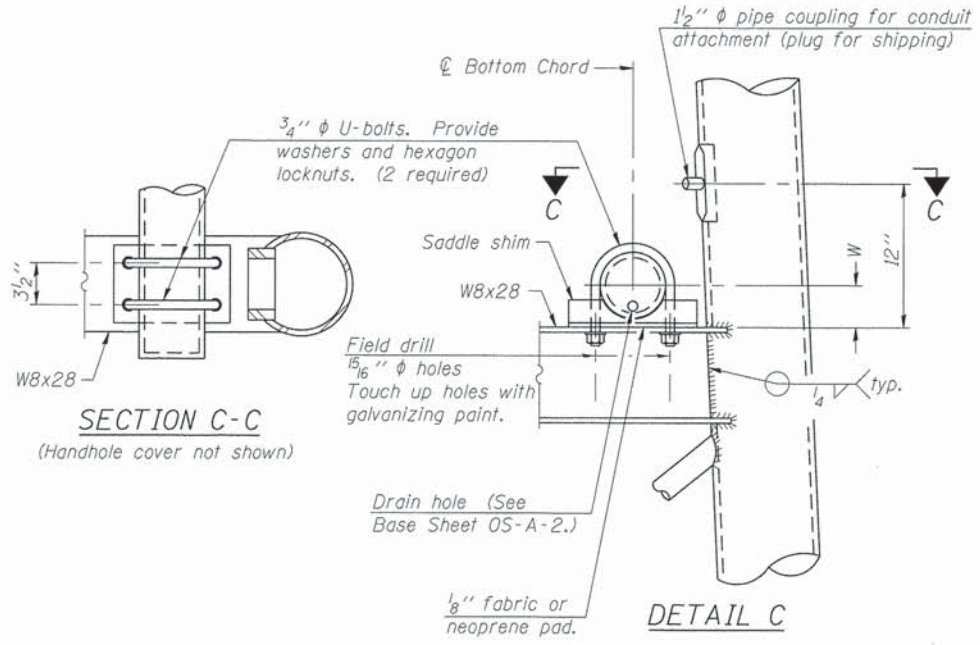

**SECTION C-C**  
(Handhole cover not shown)

**DETAIL C**

OS-A-6A

6-1-12

FILE NAME = 09-0016-sht-signovrh06.dgn	USER NAME = IDOT	DESIGNED - JAH	REVISED -
MODEL NAME = Default	DRAWN - TJH	REVISOR -	REVISOR -
PLOT SCALE = 1:0000 ' / 1"	CHECKED - LDC	REVISOR -	REVISOR -
PLOT DATE = 4/26/2014	DATE - April 29, 2014	REVISOR -	REVISOR -

STATE OF ILLINOIS  
DEPARTMENT OF TRANSPORTATION

OVERHEAD SIGN STRUCTURES  
SUPPORT FRAME DETAILS - ALUMINUM TRUSS

SCALE: SHEET NO. 6 OF 11 SHEETS STA. TO STA.

F.A.I. RTE.	SECTION	COUNTY	TOTAL SHEETS	SHEET NO.
64	09-00365-01-PV	ST. CLAIR	535	274
TR RTE. 222 (RIEDER ROAD)			CONTRACT NO. 97549	
ILLINOIS				

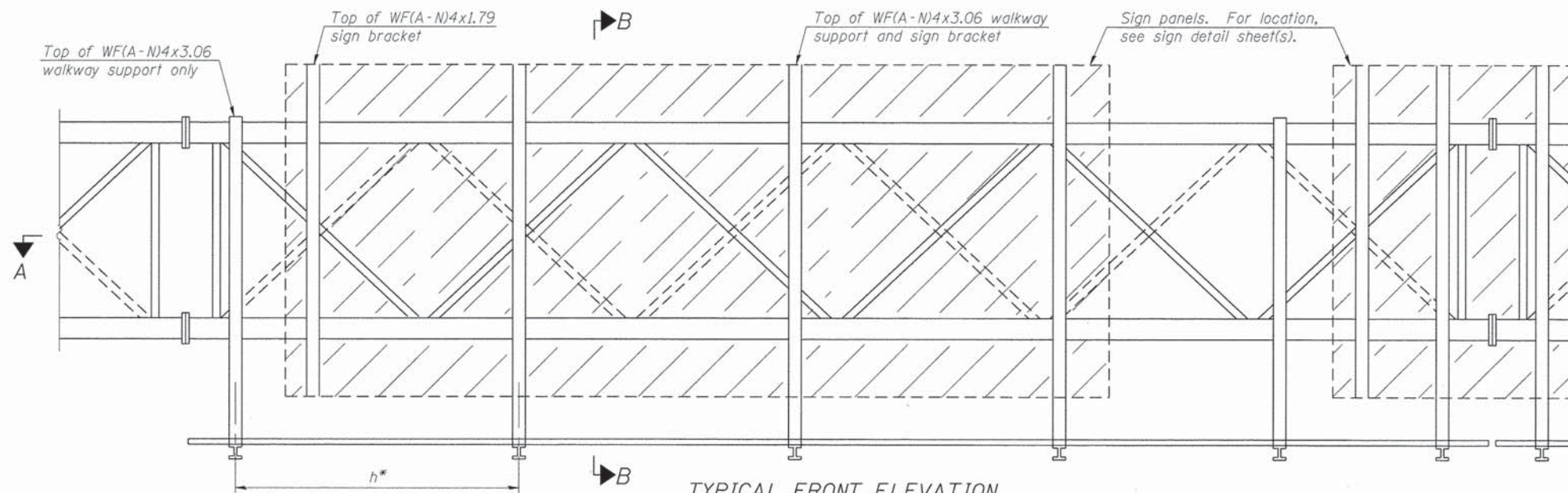

**TYPICAL FRONT ELEVATION**

With lights and handrail omitted for clarity.  
For Section B-B, see Base Sheet OS-A-10.

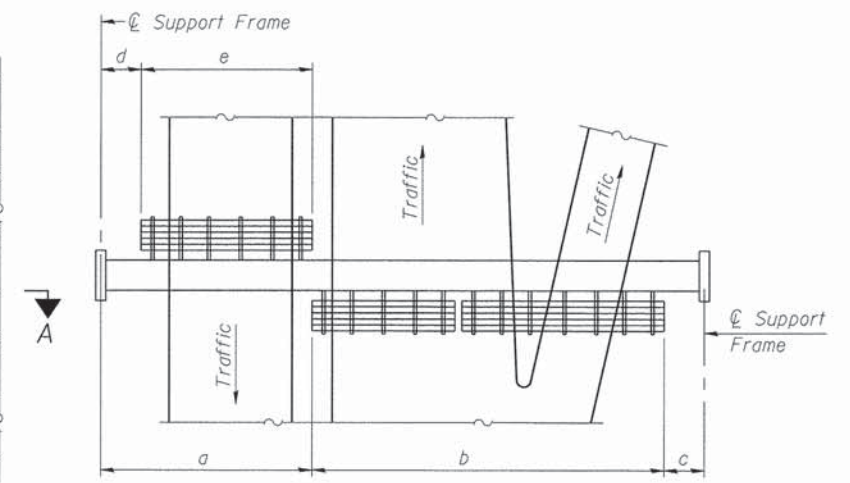

**PLAN WALKWAY AND HANDRAIL SKETCH**  
(Road plan beneath truss varies)

**BRACKET TABLE**

WF(A-N)4x1.79 or WF(A-N)4x3.06 ASTM B308, Alloy 6061-T6		
Sign Width		Number Brackets Required
Greater Than	Less Than or Equal To	
	8'-0"	2
8'-0"	14'-0"	3
14'-0"	20'-0"	4
20'-0"	26'-0"	5
26'-0"	32'-0"	6

**Notes:**

\* Space walkway brackets WF(A-N)4x3.06 and sign brackets WF(A-N)4x1.79 for efficiency and within limits shown:

f = 12" maximum, 4" minimum (End of sign to center of nearest bracket)

g = 12" maximum, 4" minimum (End of walkway grating to center of nearest support bracket)

h = 6'-0" maximum (center to center of sign and/or walkway support brackets, WF(A-N)4x1.79 or WF(A-N)4x3.06)

k = 2" maximum gap between adjacent walkway grating sections and handrail ends

\*\* If walkway bracket at safety chain location is behind sign, add angle to bracket, see Alternate Safety Chain Attachment on Base Sheet OS-A-11.

For Details T and W, Section B-B and Grating Splice Details see Base Sheet OS-A-10.

For Handrail Details see Base Sheet OS-A-11.

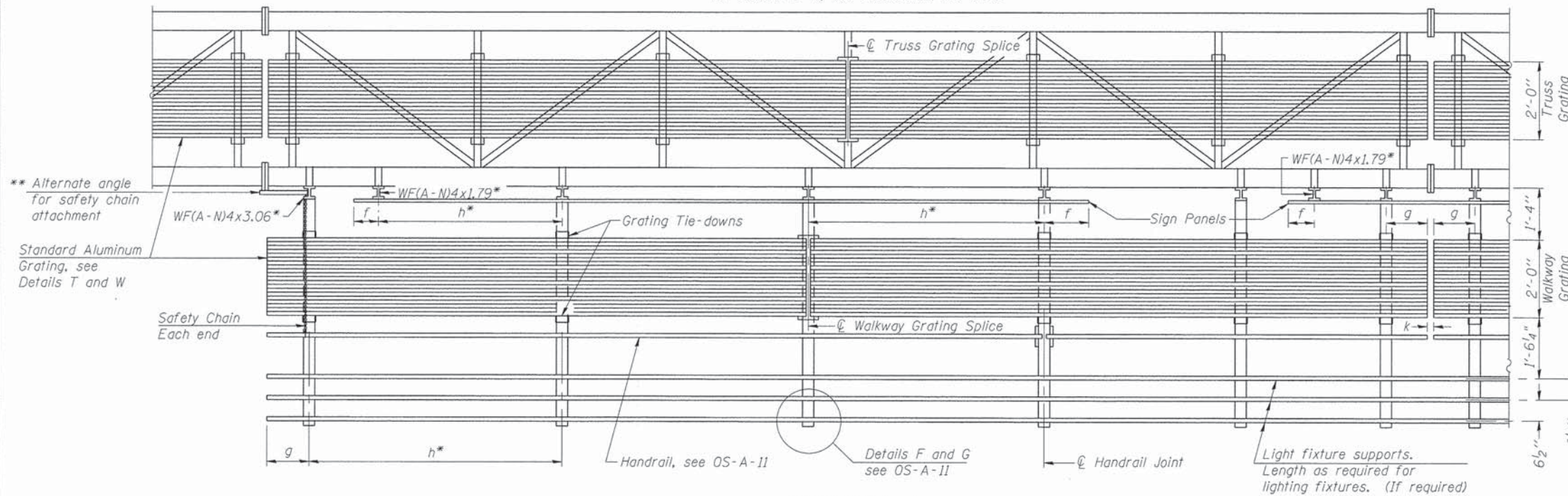

**SECTION A-A**

Handrail and walkway shall span a minimum of three brackets between splices and/or gap joints. Place all sign and walkway brackets as close to panel points as practical. Handrail joints, grating, and light support splices placed as needed.

Structure Number	Station	a	b	c	d	e	Walkway Grating and Handrail Lengths
8S0821064R018.4	894+56	20'-0"	60'-0"	24'-0"	N/A	N/A	60'-0"
8S0821064L019.1	931+02	N/A	N/A	N/A	29'-0"	59'-0"	59'-0"

Truss grating to facilitate inspection shall run full length (center to center of support frames) ±12" on overhead trusses. Cost of truss grating is included in "Overhead Sign Structure".

Walkway and Truss Grating width dimensions are nominal and may vary ±1/2" based on available standard widths.

OS-A-9

6-1-12

FILE NAME = 09-0816-sht-signovrhd07.dgn

USER NAME = IDOT

DESIGNED - JAH

REVISED -

MODEL NAME = Default

DRAWN - TJH

REVISED -

PLOT SCALE = 1/8" = 1'-0"

CHECKED - LDC

REVISED -

PLOT DATE = 4/26/2014

DATE - Apr 29, 2014

REVISED -

**STATE OF ILLINOIS  
DEPARTMENT OF TRANSPORTATION**

**OVERHEAD SIGN STRUCTURES  
ALUMINUM WALKWAY DETAILS**

SCALE: SHEET NO. 7 OF 11 SHEETS STA. TO STA.

F.A.I. RTE.	SECTION	COUNTY	TOTAL SHEETS	SHEET NO.
64	09-00365-01-PV	ST. CLAIR	535	275
TR RTE. 222 (RIEDER ROAD)			CONTRACT NO. 97549	
ILLINOIS				

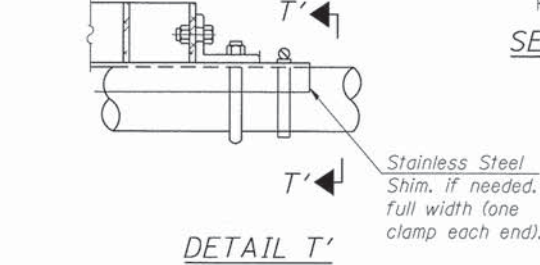
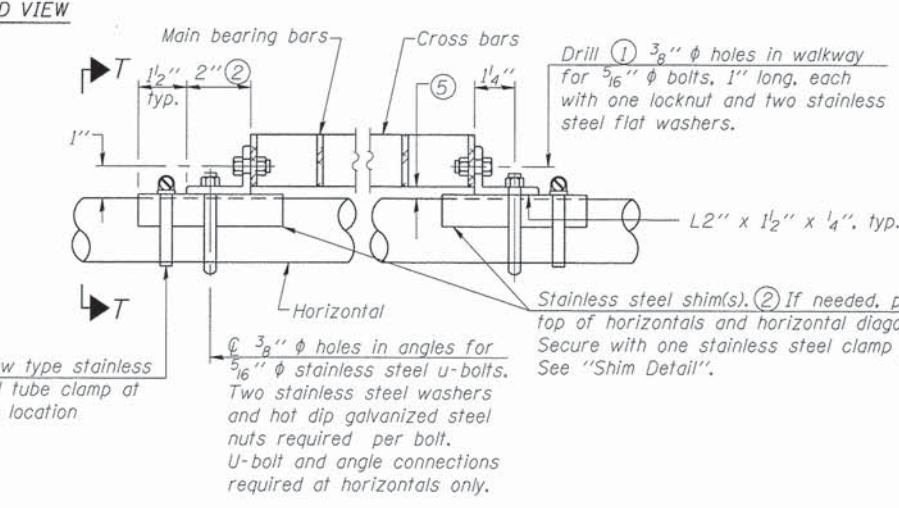
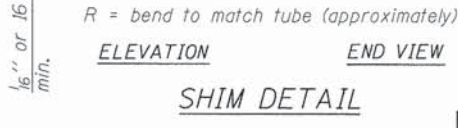
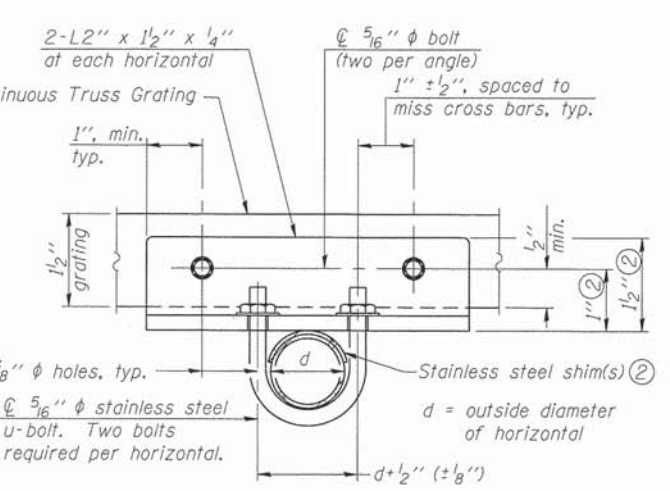
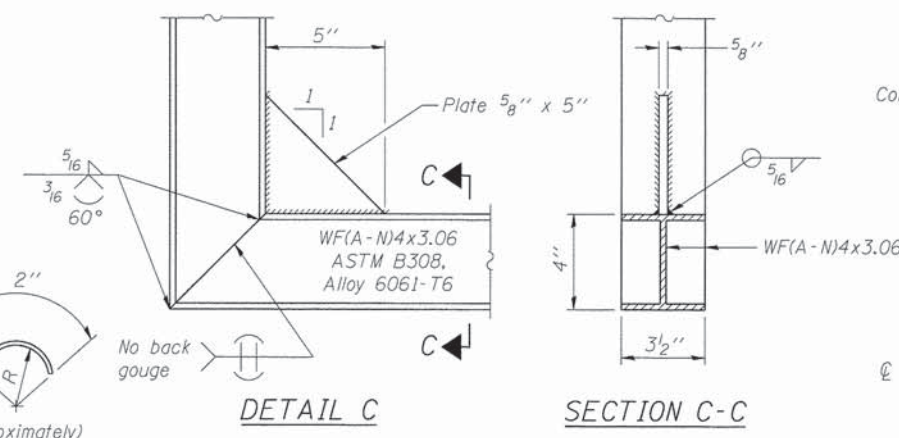
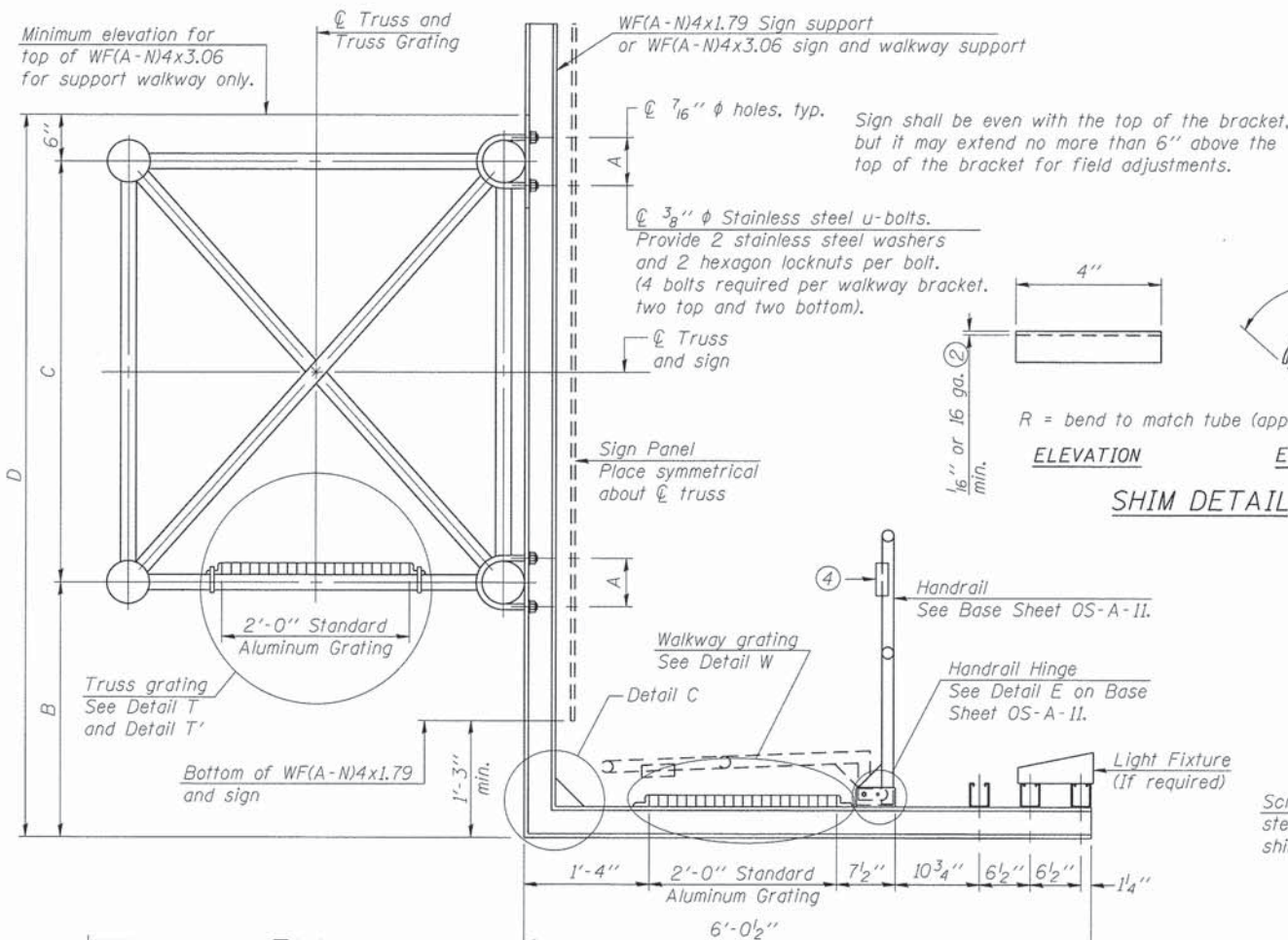

(Truss grating splice)  
Details not shown same as Detail T.  
Alternate materials may be used subject to the Engineer's review and approval.

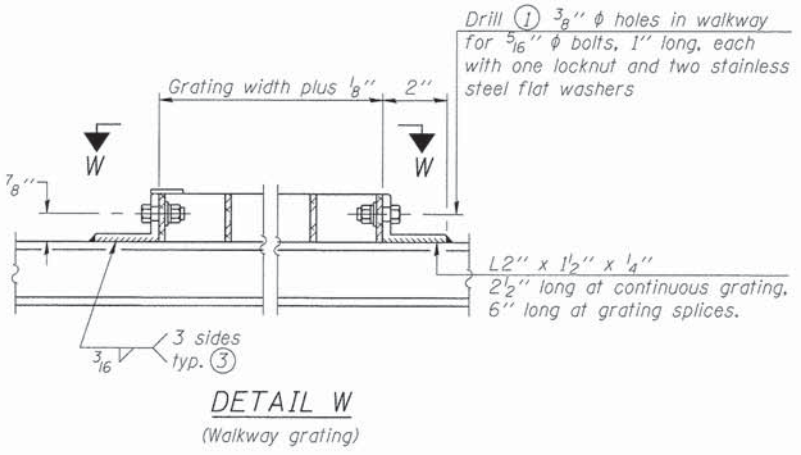
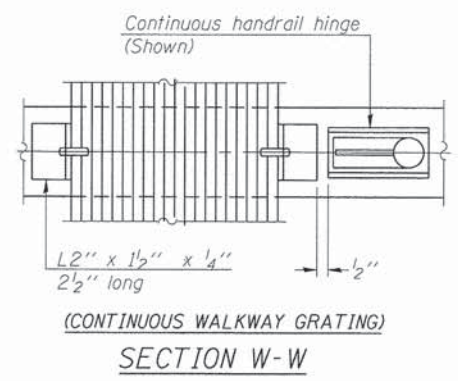
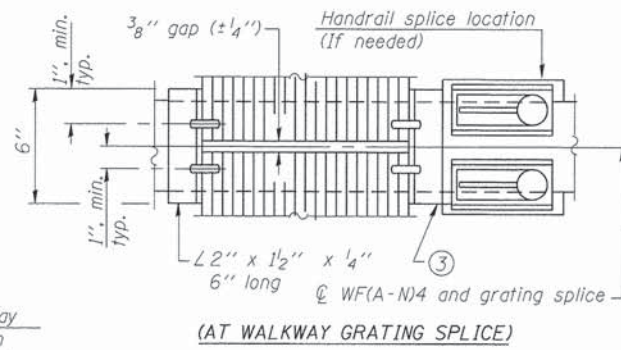

**SPECIFICATIONS FOR STANDARD ALUMINUM GRATING**

Main Bearing Bars shall be 3/16" x 1/2" on 1 3/16" centers and conform to ASTM B221 Alloy 6061-T6.  
Cross bars shall be 3/16" x 1/2" on 4" centers and conform to ASTM B221 Alloy 6063-T5 or 6061-T6.

OR

Aluminum Grating with modified "T" sections for main bearing bars shall meet the following requirements:  
Main bars shall conform to ASTM B221 Alloy 6061-T6 and have a minimum section modulus equal to 0.0705 in.<sup>3</sup> per bar, a depth of 1 1/2", spaced on 1 3/16" centers.  
Cross bars shall conform to ASTM B221 Alloy 6063-T5 or T-42 and spaced on 4" centers.

Structure Number	Station	A	⑥ B	C	⑥ D
BS0821064R018.4	894+56	7'-0"	4'-7 1/2"	5'-3"	10'-4 1/2"
BS0821064L019.1	931+02	7'-0"	4'-7 1/2"	5'-3"	10'-4 1/2"

- Drilling holes in grating may be done in shop or field, based on Contractor's preference and subject to accurate alignment.
- Stainless steel shims shall be placed as shown in Detail T if needed to compensate for alignment variations between horizontal and diagonal pipes beyond adjustment provided by angles. Thicker shims may be used subject to shims performing properly.
- If Handrail Joint present, weld angle to WF(A-N)4 and 1/4" extension bars. (See Base Sheet OS-A-II.)
- 1/8" x 1/2" x 2" welded to handrail posts to protect locations that contact grating.
- Tube to grating gap may vary from 0 to 1/2", max. to align walkway, allow for camber, etc.
- Based on actual height of tallest sign given on OS-A-I.

OS-A-10

6-1-12

FILE NAME = 09-0816-sht-signovrhd08.dgn	USER NAME = IDOT	DESIGNED - JAH	REVISED -
MODEL NAME = Default	DRAWN - TJH	REVISIONS -	
PLOT SCALE = 1:80000' / in.	CHECKED - LDC	REVISIONS -	
PLOT DATE = 4/26/2014	DATE - Apr 11 29, 2014	REVISIONS -	

STATE OF ILLINOIS  
DEPARTMENT OF TRANSPORTATION

OVERHEAD SIGN STRUCTURES  
ALUMINUM WALKWAY DETAILS

SCALE: SHEET NO. 8 OF 11 SHEETS STA. TO STA.

F.A.I. RTE.	SECTION	COUNTY	TOTAL SHEETS	SHEET NO.
64	09-00365-01-PV	ST. CLAIR	535	276
TR RTE. 222 (RIEDER ROAD)		CONTRACT NO. 97549		
ILLINOIS				

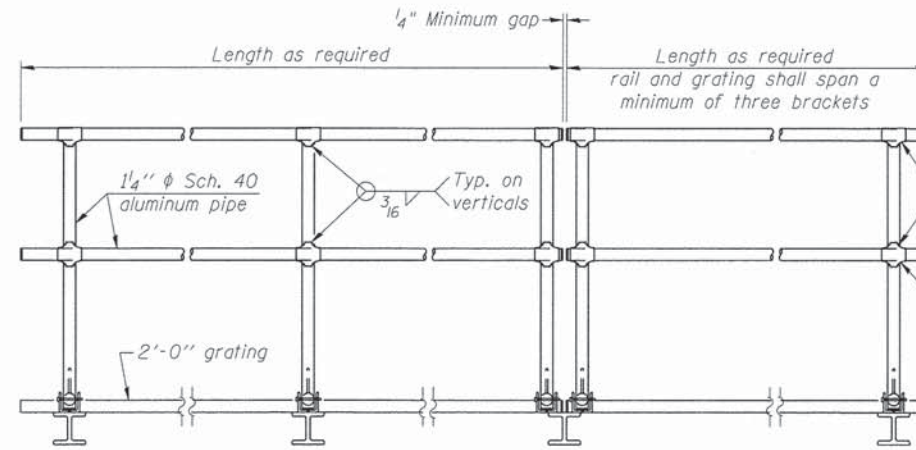
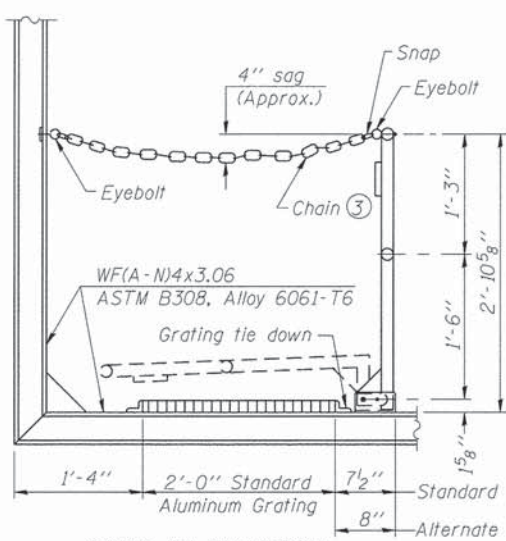

**HANDRAIL DETAILS**

Handrail pipe shall be ASTM B241 or B429, Alloy 6063-T6 or Alloy 6061-T6.

- ① Install standard force-fit end caps or weld 1/8" end plates with 1/8" c.f.w. and grind smooth. (All rail ends)
- ② Horizontal handrail member shall be continuous thru fitting. Provide 7/16" hole in fitting for 3/8" bolt. Field drill 7/16" hole in horizontal rail member. Provide locknut and two stainless steel washers for bolt. (Use 5/16" eyebolts in 7/16" holes on top rail at ends only.)

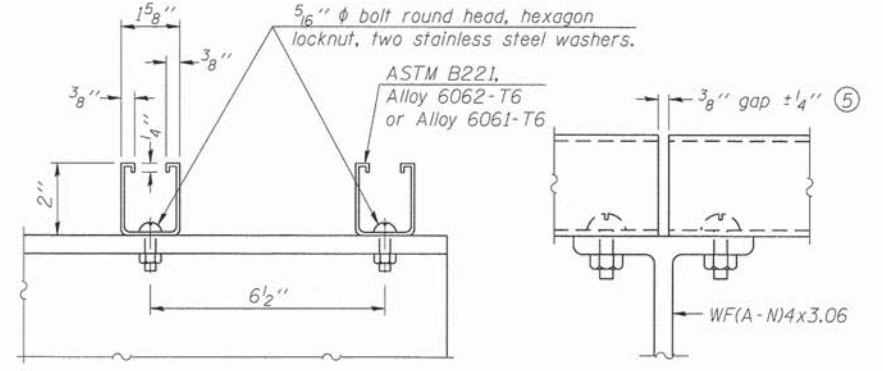
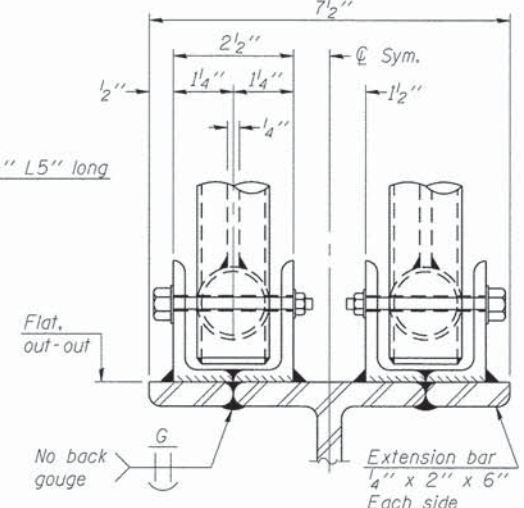
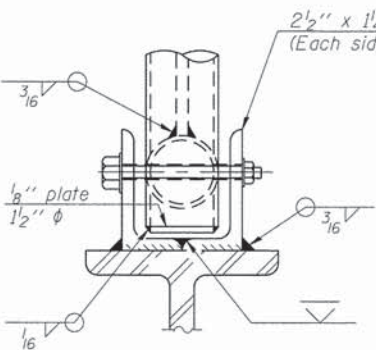
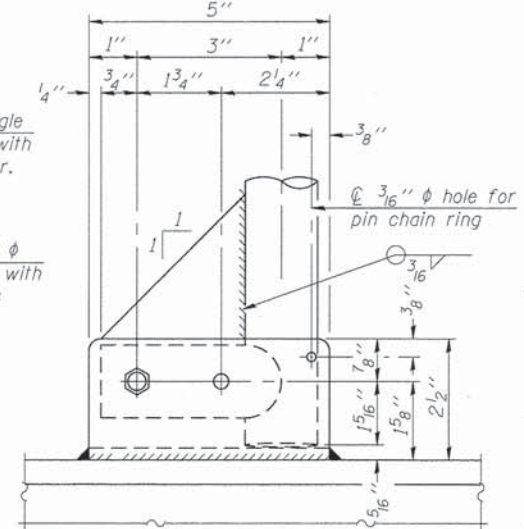
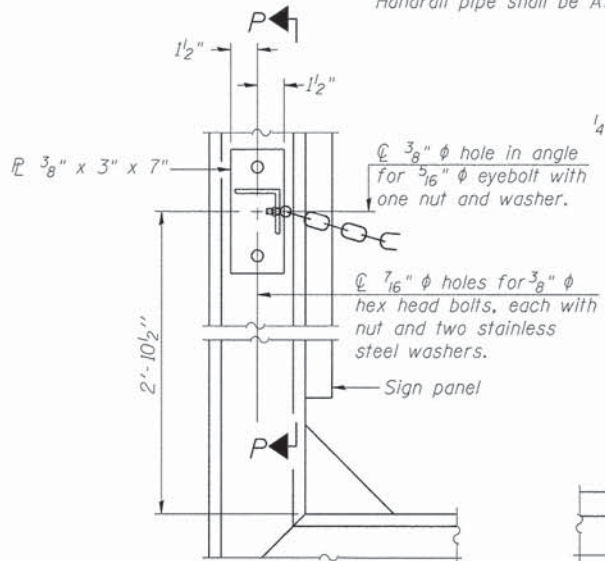
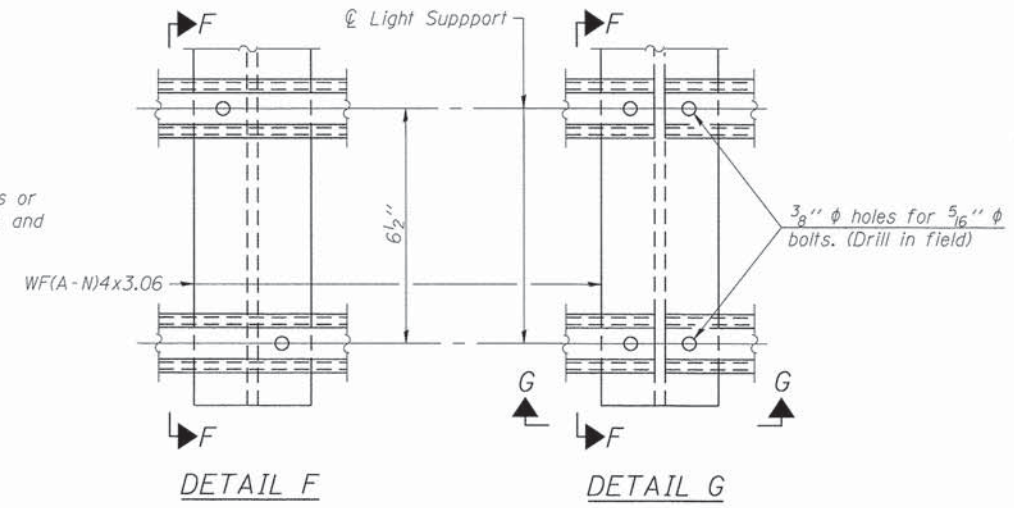

**LIGHTING FIXTURE MOUNTS (IF REQUIRED)**

- ⑤ Field cut ends of light support channels shall be free of burrs or hazardous projections and coated with zinc-rich primer or equivalent.

**ALTERNATE SAFETY CHAIN ATTACHMENT**

(With Sign Present)  
Items not shown same as "Side Elevation" of "Handrail Details"

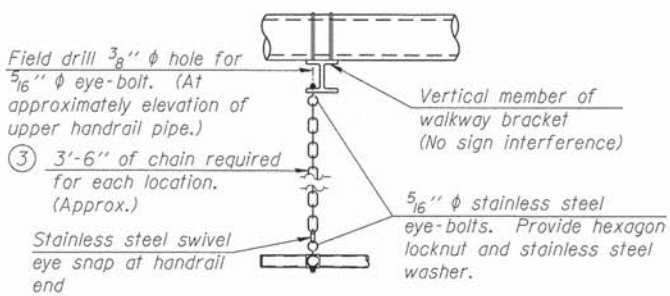
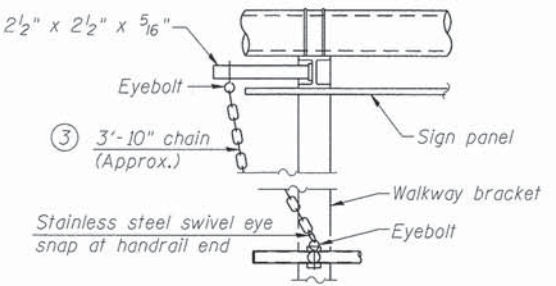
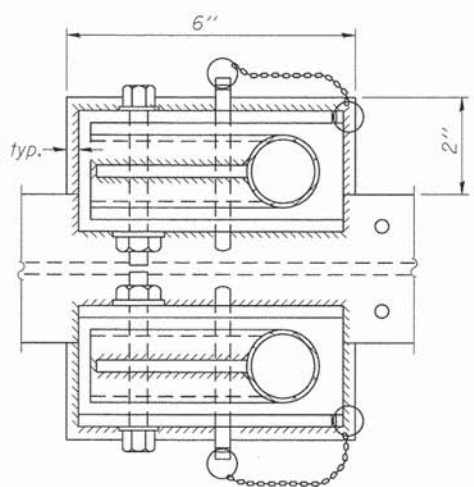
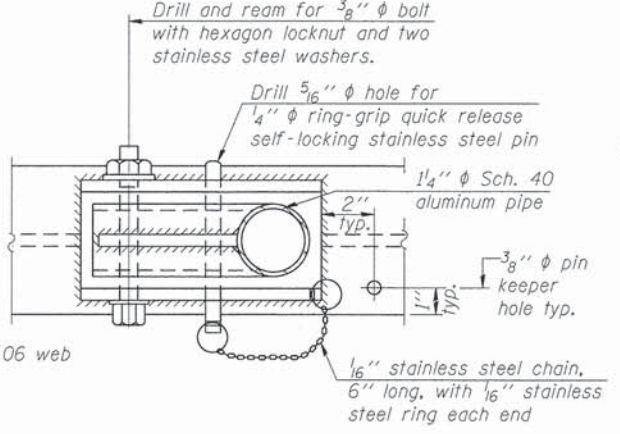
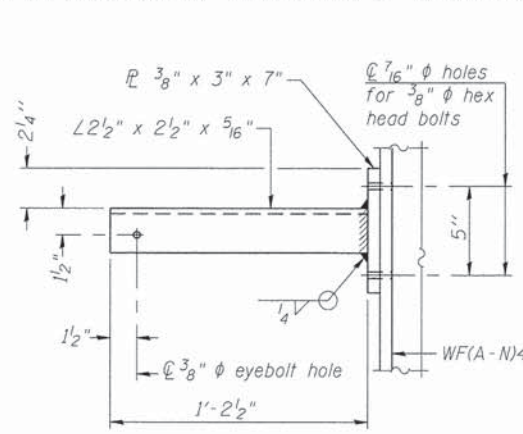

**ALTERNATE SAFETY CHAIN ATTACHMENT**

Details not shown similar to "Safety Chain" Details (Walkway omitted for clarity)

**SAFETY CHAIN**

One required for each end of each walkway.

- ③ 3/16" Type 304L stainless steel chain, approximately 12 links per foot.
- ④ Extrusions may be used in lieu of the details shown, with approval of the Engineer.

OS-A-11

6-1-12

FILE NAME = 09-0016-shr-signovrhd29.dgn	USER NAME = IDOT	DESIGNED - JAH	REVISED -
MODEL NAME = Default	DRAWN - TJH	REVISOR -	REVISOR -
PLOT SCALE = 1:8000 @ 1/8" = 1'	CHECKED - LDC	REVISOR -	REVISOR -
PLOT DATE = 4/26/2014	DATE - April 29, 2014	REVISOR -	REVISOR -

STATE OF ILLINOIS  
DEPARTMENT OF TRANSPORTATION

OVERHEAD SIGN STRUCTURES  
ALUMINUM HANDRAIL DETAILS

SCALE: SHEET NO. 9 OF 11 SHEETS STA. TO STA.

F.A.I. RTE.	SECTION	COUNTY	TOTAL SHEETS	SHEET NO.
64	09-00365-01-PV	ST. CLAIR	535	277
TR RTE. 222 (RIEDER ROAD)		CONTRACT NO. 97549		
ILLINOIS				

**BAR LIST - EACH FOUNDATION**

Bar	Number	Size	Length	Shape
v4(E)	24	#9	F less 5"	—
#4 bar spiral (E) - see Side Elevation				

**NOTES:**

The foundation dimensions shown are based on the presence of mostly cohesive soils with an average Unconfined Compressive Strength (Qu) of at least 1.25 tsf, which must be determined by previous soil investigations at the jobsite. When other conditions are indicated, the boring data will be included in the plans and the foundation dimensions shown will be the result of site specific designs.

If the conditions encountered are different than those indicated, the Contractor shall notify the Engineer to determine if the foundation dimensions need to be modified. If dimensions "B" or "F" are revised by more than 12" by the Contractor, "as-built" plans shall be prepared and submitted to the District Bureau of Operations for future reference.

No sonotubes or decomposable forms shall be used below the lower conduit entrance. Permanent metal forms or other shielding may not be left in place below that elevation without the Engineer's written permission.

Concrete shall be placed monolithically, without construction joints.

Backfill shall be placed per Article 502 of Standard Specification and prior to erection of support column.

A normal surface finish followed by a Bridge Seat Sealer application will be required on concrete surfaces above the lowest elevation 6" below finished ground line. Cost included in Drilled Shaft Concrete Foundation.

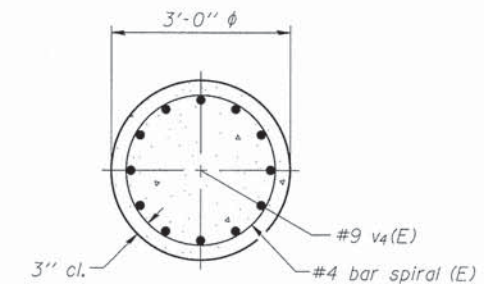
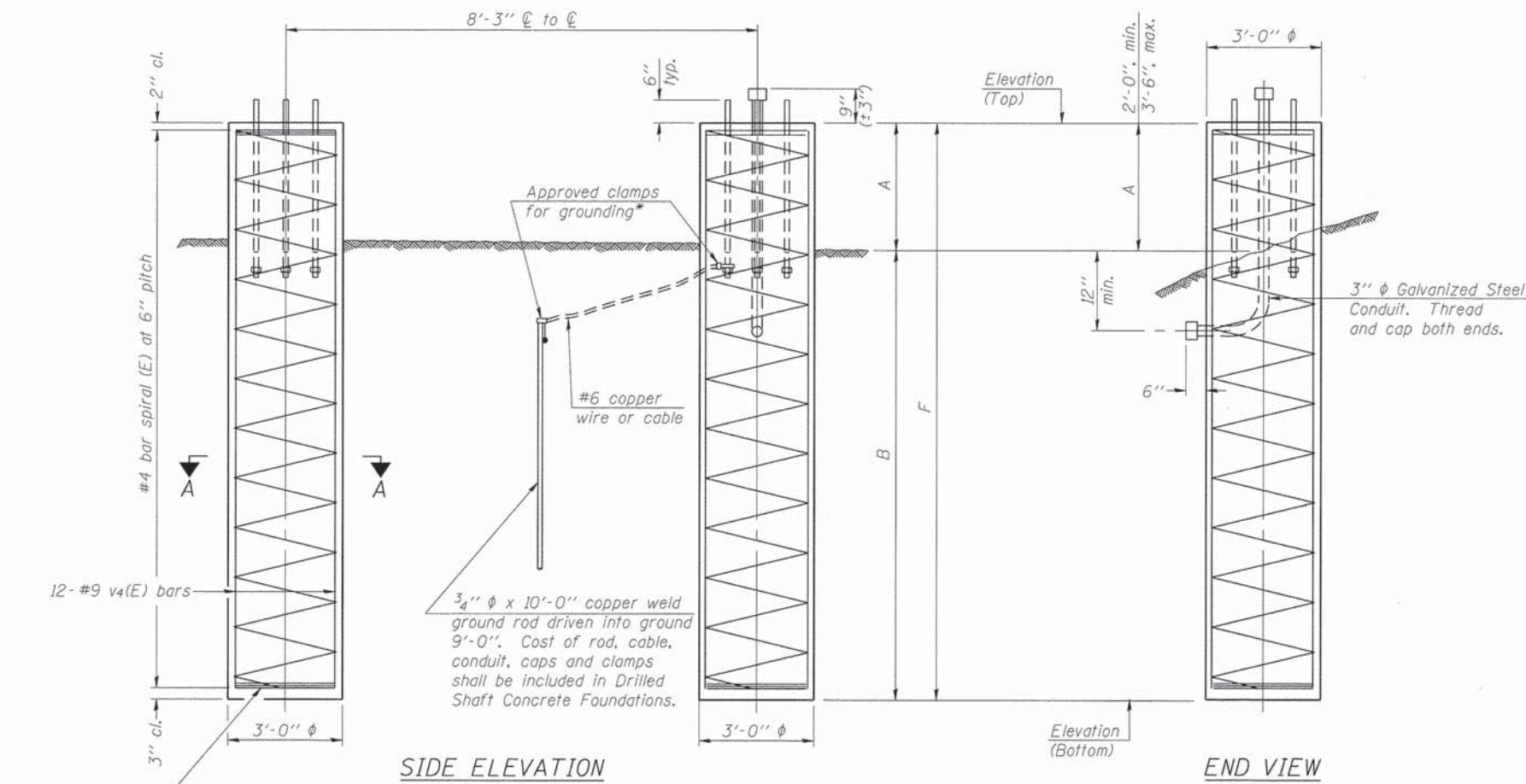

**SECTION A-A**

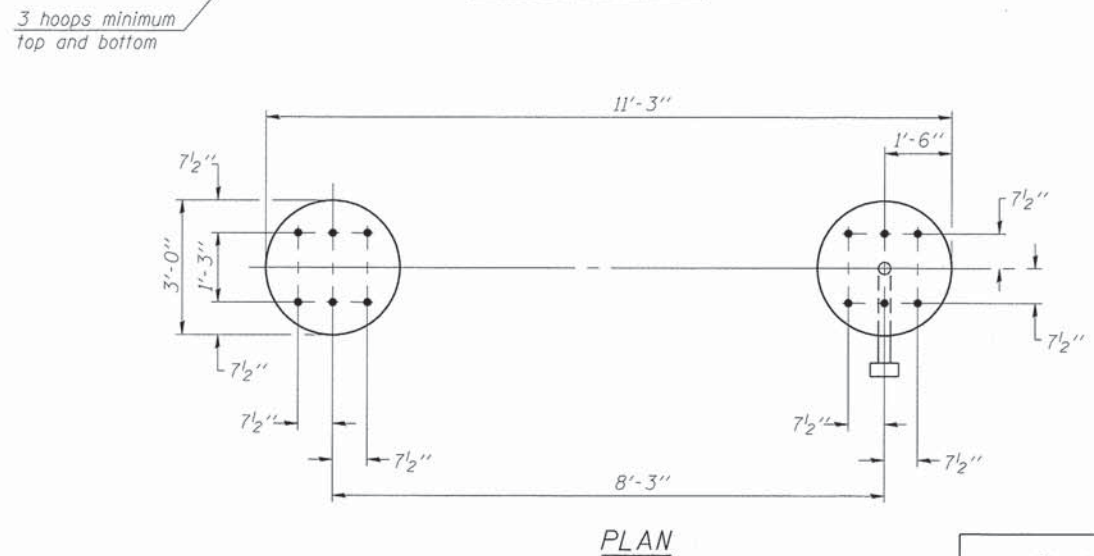

**PLAN**

For anchor rod size and placement, see Support Frame Detail Sheet.

\* Anchor rod shall be ground or filed to bright metal at clamp and cable connection location.

**DETAILS FOR 10" Ø SUPPORT FRAME  
TYPE I-A or II-A TRUSS**

Structure Number	Station	Left Foundation					Right Foundation					Class DS Concrete (Cu. Yds.)
		Elevation Top	Elevation Bottom	A	B	F	Elevation Top	Elevation Bottom	A	B	F	
8S0821064R018.4	894+56						523.01	499.93	2'-7"	20'-6"	23'-1"	12.1
8S0821064L019.1	931+02	487.41	464.33	2'-7"	20'-6"	23'-1"						12.1

P:\05-0816-02\_Roadway\_Road\_Phase\_1\1108\_CADD\CADD\_Sheets\09-0816-0216-shr-signovr-hd1.dgn  
 OS4-F3  
 6-1-12

OS4-F3

6-1-12

FILE NAME = 09-0816-shr-signovr-hd1.dgn	USER NAME = IDOT	DESIGNED - JAH	REVISED -
MODEL NAME = Default	DRAWN - TJH	REVISOR -	REVISOR -
PLOT SCALE = 1/8" = 1'-0"	CHECKED - LDC	REVISOR -	REVISOR -
PLOT DATE = 4/26/2014	DATE - Apr 29, 2014	REVISOR -	REVISOR -

**STATE OF ILLINOIS  
DEPARTMENT OF TRANSPORTATION**

**OVERHEAD SIGN STRUCTURES  
DRILLED SHAFT DETAILS**

SCALE: SHEET NO. 10 OF 11 SHEETS STA. TO STA.

F.A.I. RTE.	SECTION	COUNTY	TOTAL SHEETS	SHEET NO.
64	09-00365-01-PV	ST. CLAIR	535	278
TR RTE. 222 (RIEDER ROAD)			CONTRACT NO. 97549	
ILLINOIS				

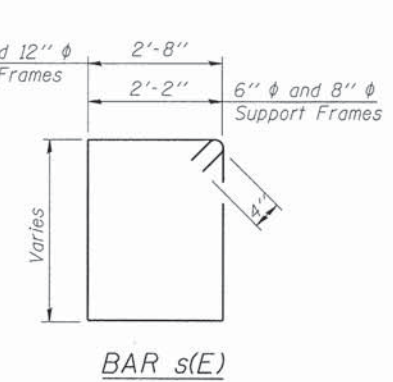
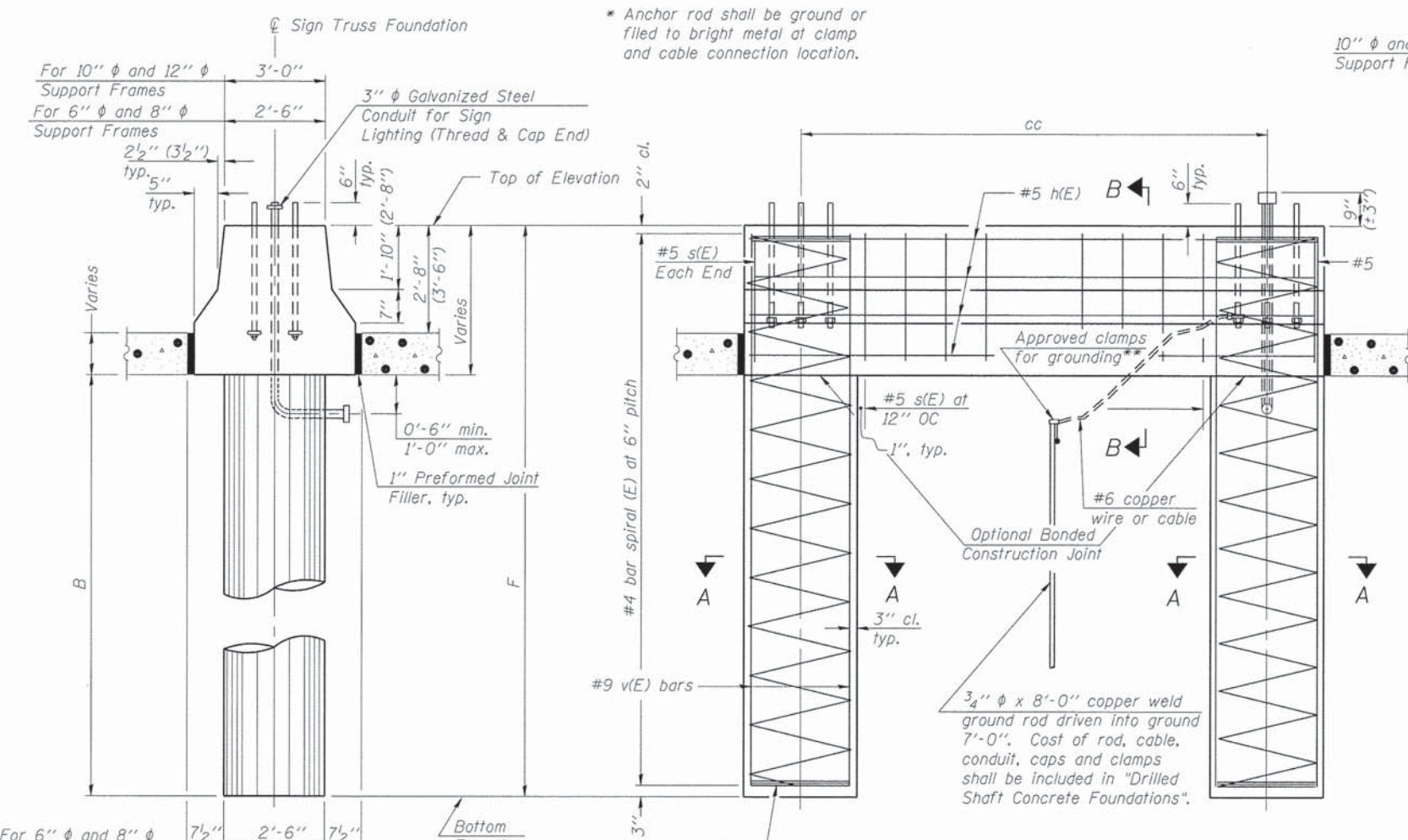

**NOTES:**  
 The foundation dimensions shown are based on the presence of mostly cohesive soils with an average Unconfined Compressive Strength (Qu) of at least 1.25 tsf, which must be determined by previous soil investigations at the jobsite. When other conditions are indicated, the boring data will be included in the plans and the foundation dimensions shown will be the result of site specific designs.  
 If the conditions encountered are different than those indicated, the Contractor shall notify the Engineer to determine if the foundation dimensions need to be modified. If dimensions "B" or "F" are revised by more than 12" by the Contractor, "as-built" plans shall be prepared and submitted to the District Bureau of Operations for future reference.  
 No sonotubes or decomposable forms shall be used below the lower conduit entrance. Permanent metal forms or other shielding may not be left in place below that elevation without the Engineer's written permission.  
 Concrete shall be placed monolithically, without construction joints.  
 Backfill shall be placed per Article 502 of Standard Specification and prior to erection of support column.  
 A normal surface finish followed by a Bridge Seat Sealer application will be required on concrete surfaces above the lowest elevation 6" below finished ground line. Cost included in Drilled Shaft Concrete Foundation.

Pipe Support Frames	cc	M	a	a/2
6"φ	7'-0"	9'-6"	0'-11"	5 1/2"
8"φ	7'-6"	10'-0"	1'-1 1/2"	6 3/4"
10"φ	8'-3"	11'-3"	1'-3"	7 1/2"
12"φ	9'-0"	12'-0"	1'-6"	9"

**BAR LIST - EACH FOUNDATION**

Bar	Number	Size	Length	Shape
h(E)	10	#5	M less 4"	—
s(E)	Varies	#5	Varies	□
v(E)	16	#9	F less 0'-5"	—
v(E)	24	#9	F less 0'-5"	—

#4(E) bar spiral - see Side Elevation

6" φ and 8" φ Support Frame  
 10" φ and 12" φ Support Frame

All dimensions in parenthesis are for 42" high barrier.

**SIDE ELEVATION**  
 Concrete Foundation poured monolithically with no construction joint.

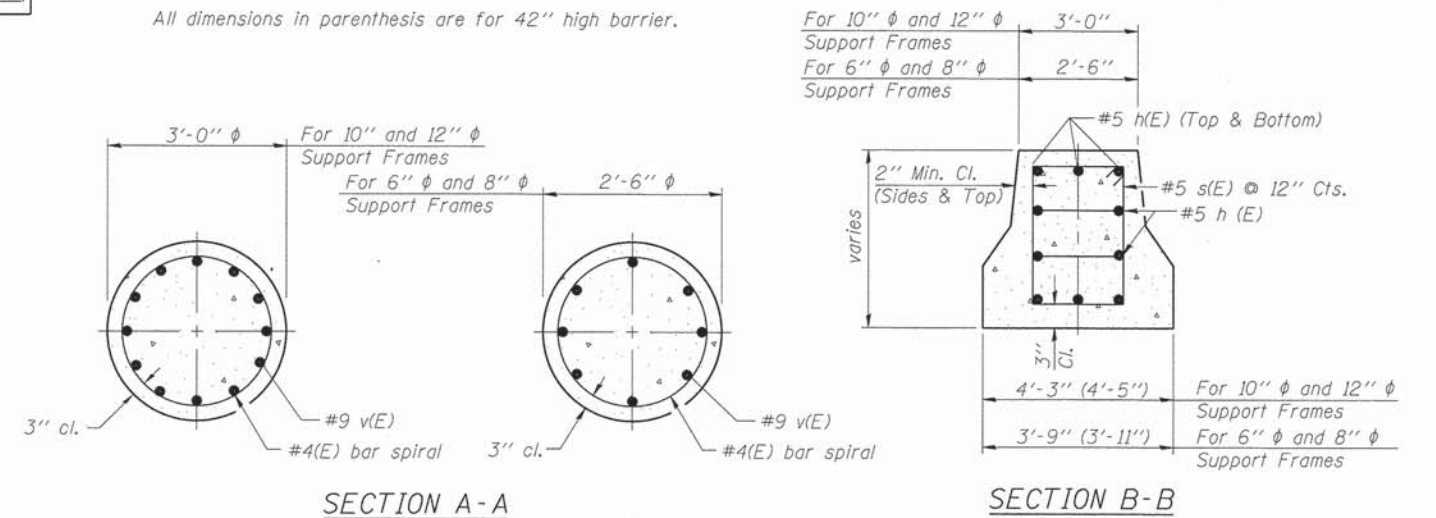

**END VIEW**

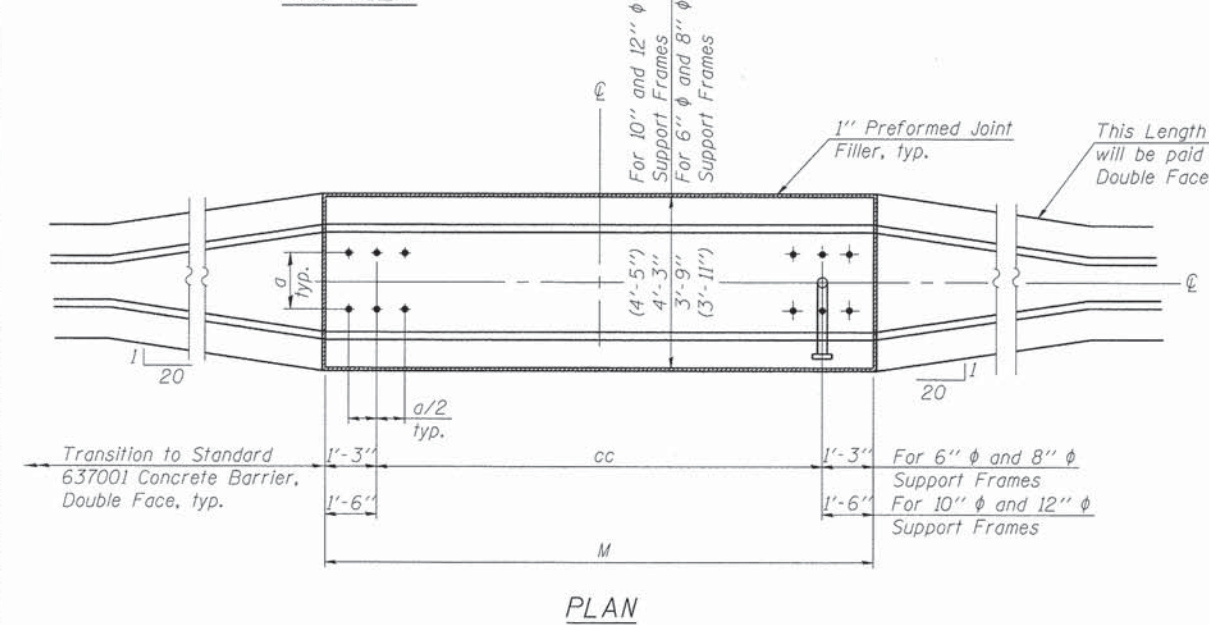

Structure Number	Station	Left Foundation		Right Foundation		Class DS Concrete (Cu. Yds.)				
		Elevation Top	Elevation Bottom	B	F		Elevation Top	Elevation Bottom	B	F
8S0821064R018.4	894+56	529.68	503.43	20'-6"	26'-3"	19.7				
8S0821064L019.1	931+02					493.66	468.33	20'-6"	25'-4"	18.2

**GENERAL NOTES**

DESIGN: AASHTO Standard Specifications for Structural Supports for Highway Signs, Luminaires and Traffic Signals. ("AASHTO Specifications")

CONSTRUCTION: Current (at time of letting) Illinois Department of Transportation Standard Specifications for Road and Bridge Construction, Supplemental Specifications and Special Provisions. ("Standard Specifications")

LOADING: 90 M.P.H. WIND VELOCITY

WALKWAY LOADING: Dead load plus 500 lbs. concentrated live load.

DESIGN STRESSES:

Field Units  
 $f_c = 3,500$  p.s.i.  
 $f_y = 60,000$  p.s.i. (reinforcement)

WELDING: All welds to be continuous unless otherwise shown. All welding to be done in accordance with current AWS D1.1 and D1.2 Structural Welding Codes (Steel and Aluminum) and the Standard Specifications.

MATERIALS: Aluminum Alloys as shown throughout plans. All Structural Steel Pipe shall be ASTM A53 Grade B or A500 Grade B or C. If A500 pipe is substituted for A53, then the outside diameter shall be as detailed and wall thickness greater than or equal to A53.

All Structural Steel Plates and Shapes shall conform to AASHTO M270 Gr. 36, Gr. 50 or Gr. 50W\*. Stainless steel for shims, sleeves and handhole covers shall be ASTM A240, Type 302 or 304, or another alloy suitable for exterior exposure and acceptable to the Engineer.

The steel pipe and stiffening ribs at the base plate for the column shall have a minimum longitudinal Charpy V-Notch (CVN) energy of 15 lb.-ft. at 40° F. (Zone 2) before galvanizing.

FASTENERS FOR ALUMINUM TRUSSES: All bolts noted as "high strength" must satisfy the requirements of AASHTO M164 (ASTM A325), or approved alternate, and must have matching lock nuts. Threaded studs for splices (if Members interfere) must satisfy the requirements of ASTM A449, ASTM A193, Grade B7, or approved alternate, and must have matching lock nuts. Bolts and lock nuts not required to be high strength must satisfy the requirements of ASTM A307. All bolts and lock nuts must be hot dip galvanized per AASHTO M232. The lock nuts must have nylon or steel inserts. A stainless steel flat washer conforming to ASTM A240 Type 302 or 304, is required under both head and nut or under both nuts where threaded studs are used. High strength bolt installation shall conform to Article 505.04 (f) (2)d of the IDOT Standard Specifications for Road and Bridge Construction. Rotational capacity ("ROCAP") testing of bolts will not be required.

U-BOLTS AND EYEBOLTS: U-Bolts and Eyebolts must be produced from ASTM A276 Type 304, 304L, 316 or 316L, Condition A, cold finished stainless steel, or an equivalent material acceptable to the Engineer. All nuts for U-Bolts and Eyebolts must be lock nuts equivalent to ASTM A307 with nylon or steel inserts and hot dip galvanized per AASHTO M232. A stainless steel flat washer conforming to ASTM A240, Type 302 or 304, is required under each U-Bolt and Eyebolt lock nut.

GALVANIZING: All Steel Grating, Plates, Shapes and Pipe shall be Hot Dip Galvanized after fabrication in accordance with AASHTO M111. Painting is not permitted.

ANCHOR RODS: Shall conform to ASTM F1554 Gr. 105.

CONCRETE SURFACES: All concrete surfaces above an elevation 6" below the lowest final ground line at each foundation shall be cleaned and coated with Bridge Seat Sealer in accordance with the Standard Specifications.

REINFORCEMENT BARS: Reinforcement Bars designated (E) shall be epoxy coated in accordance with the Standard Specifications.

FOUNDATIONS: The contract unit price for Drilled Shaft Concrete Foundations shall include reinforcement bars complete in place.

Structure Number	Station	Design Truss Type	Cantilever Length (L)	Elev. A	Dim. D	D <sub>s</sub>	Total Sign Area
8C0821064R019.1	935+00	III-C-A	36'-0"	490.32	17'-7 <sup>3</sup> / <sub>8</sub> "	11'-6"	190
8C0821064R019.6	961+40	II-C-A	30'-0"	489.89	18'-0"	9'-0"	149
8C0821064R020.0	979+50	I-C-A	24'-6"	467.85	12'-3 <sup>3</sup> / <sub>4</sub> "	9'-0"	149

Truss Type	Maximum Sign Area	Maximum Length
I-C-A	170 Sq. Ft.	25 Ft.
II-C-A	340 Sq. Ft.	30 Ft.
III-C-A	400 Sq. Ft.	40 Ft.

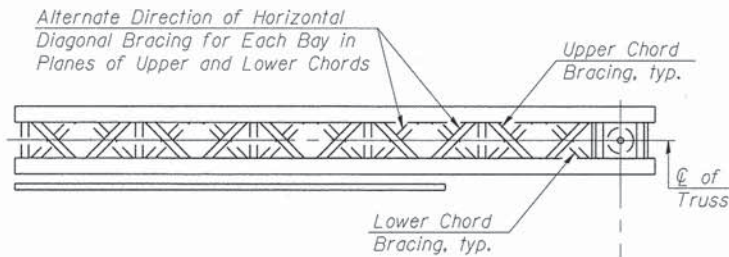

**TYPICAL PLAN**  
(Walkway not shown)

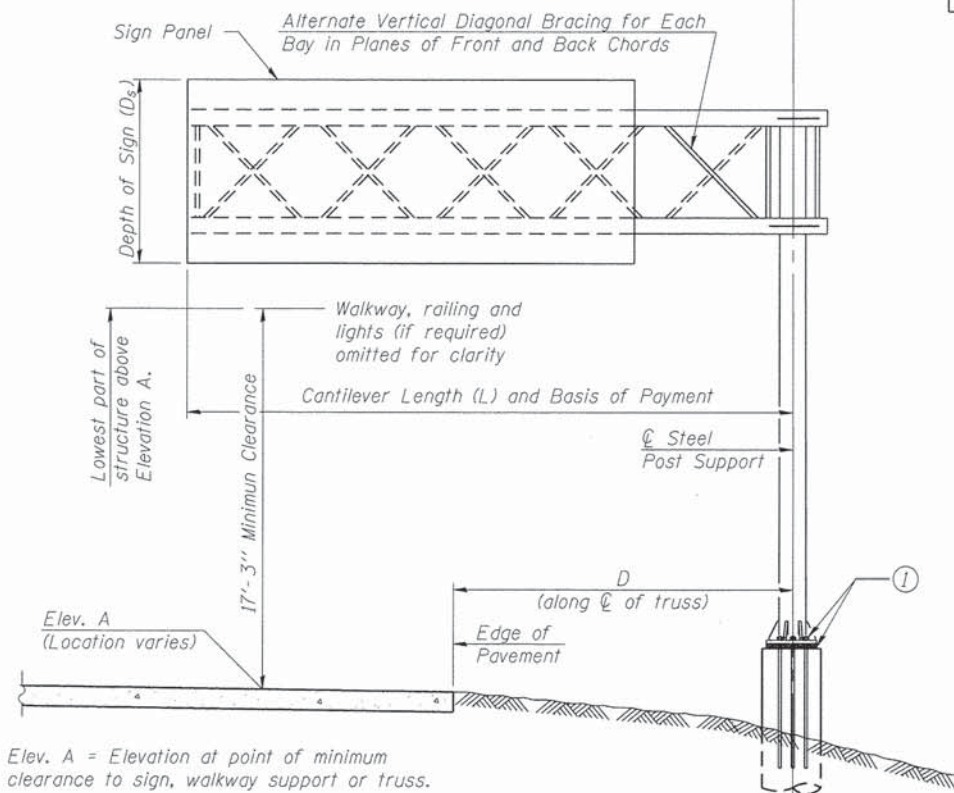

Elev. A = Elevation at point of minimum clearance to sign, walkway support or truss.

**TYPICAL ELEVATION**  
Looking in Direction of Traffic

Sign support structures may be subject to damaging vibrations and oscillations when sign panels are not in place during erection or maintenance of the structure. To avoid these vibrations and oscillations, consideration should be given to attaching temporary blank sign panels to the structure.

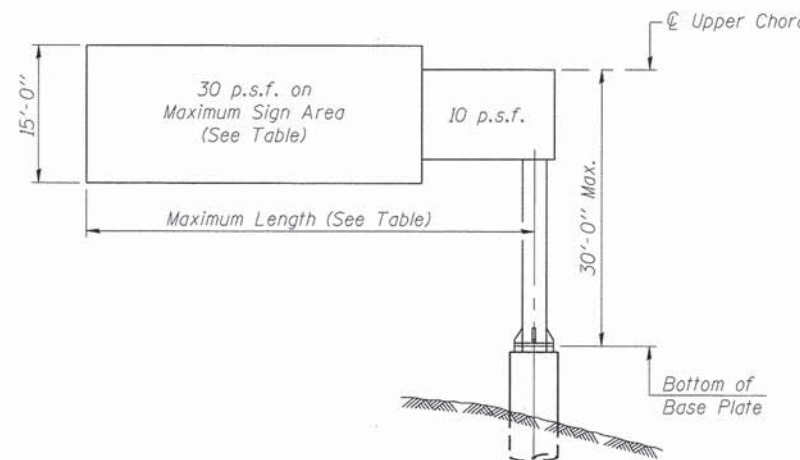

**DESIGN WIND LOADING DIAGRAM**

Parameters shown are basis for I.D.O.T. Standards. Installations not within dimensional limits shown require special analysis for all components.

Note:

Trusses shall be shipped individually with adequate provision to prevent detrimental motion during transport. This may require ropes between horizontals and diagonals or energy dissipating (elastic) ties to the vehicle. The contractor is responsible for maintaining the configuration and protection of the trusses.

1 After adjustments to level truss and insure adequate vertical clearance, all top and leveling nuts shall be tightened against the base plate with a minimum torque of 200 lb.-ft. Stainless steel mesh shall then be placed around the perimeter of the base plate. Secure to base plate with stainless steel banding.

\* If M270 Gr. 50W (M222) steel is proposed, chemistry for plate to be used shall first be approved by the Engineer as suitable for galvanizing and welding.

**TOTAL BILL OF MATERIAL**

ITEM	UNIT	TOTAL
OVERHEAD SIGN STRUCTURE CANTILEVER TYPE I-C-A	Foot	24.5
OVERHEAD SIGN STRUCTURE CANTILEVER TYPE II-C-A	Foot	30.0
OVERHEAD SIGN STRUCTURE CANTILEVER TYPE III-C-A	Foot	36.0
OVERHEAD SIGN STRUCTURE WALKWAY, TYPE A	Foot	56.0
DRILLED SHAFT CONCRETE FOUNDATIONS	Cu. Yds.	28.3

P:\09-0816-02 Under Road Phase 1\118 CAD\CAD Sheets\09-0816-sht-signcant01.dgn

OSC-A-1

6-1-12

FILE NAME = 09-0816-sht-signcant01.dgn	USER NAME = IDDT	DESIGNED - JAH	REVISED -
MODEL NAME = Default	DRAWN - TJH	REVISIONS -	
PLOT SCALE = 12,0000 ' / ft.	CHECKED - LDC	REVISIONS -	
PLOT DATE = 4/27/2014	DATE - April 29, 2014	REVISIONS -	

STATE OF ILLINOIS  
DEPARTMENT OF TRANSPORTATION

CANTILEVER SIGN STRUCTURES - GENERAL PLAN & ELEVATION  
ALUMINUM TRUSS & STEEL POST

SCALE: SHEET NO. 1 OF 10 SHEETS STA. TO STA.

F.A.I. RTE.	SECTION	COUNTY	TOTAL SHEETS	SHEET NO.
64	09-00365-01-PV	ST. CLAIR	535	280
TR RTE. 222 (RIEDER ROAD)			CONTRACT NO. 97549	
ILLINOIS				



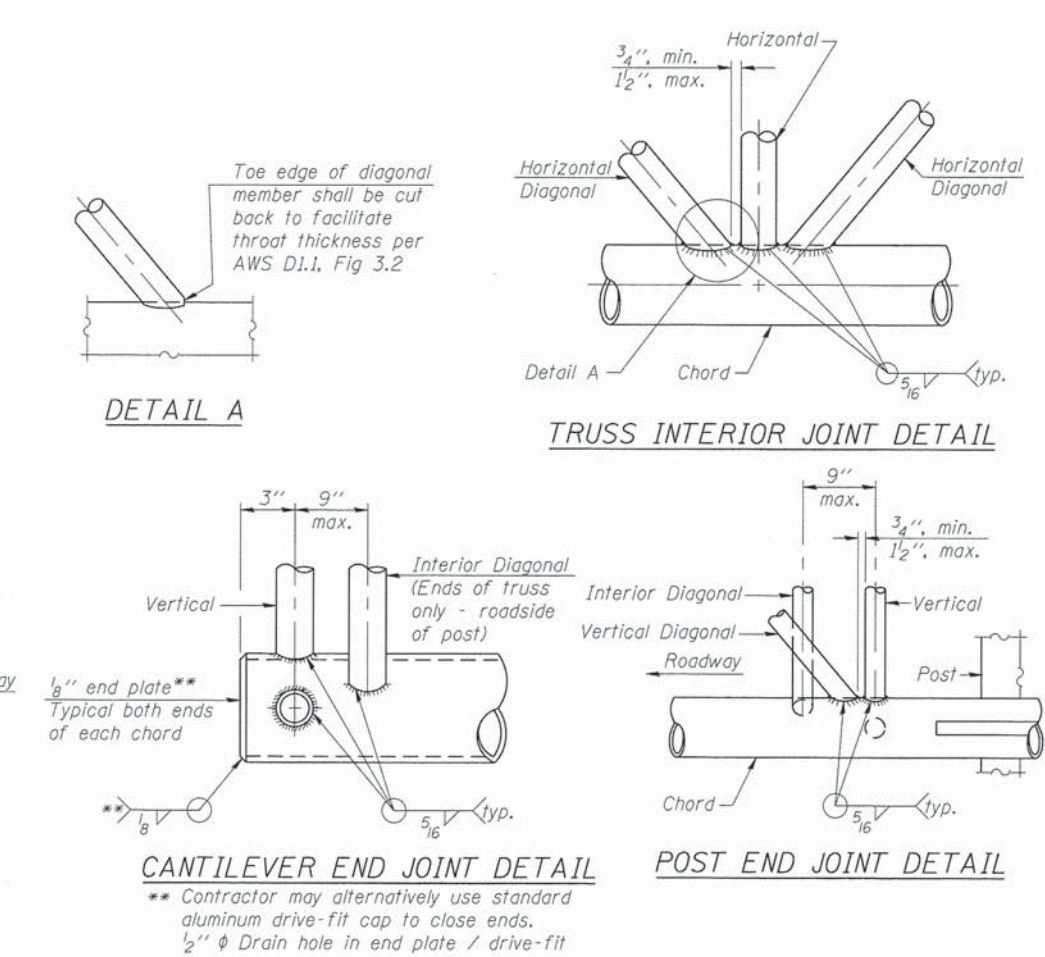
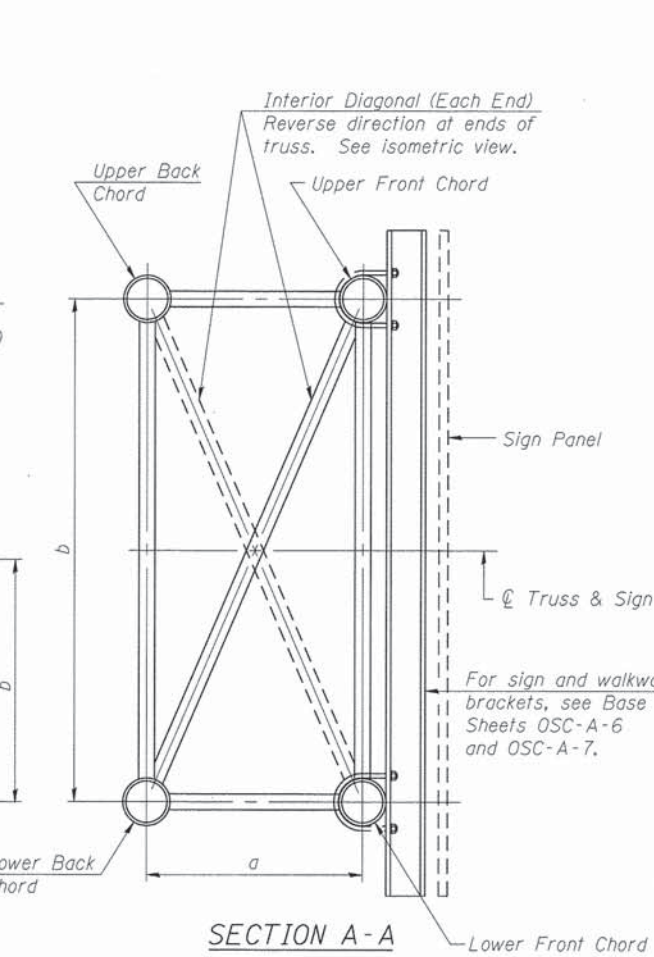
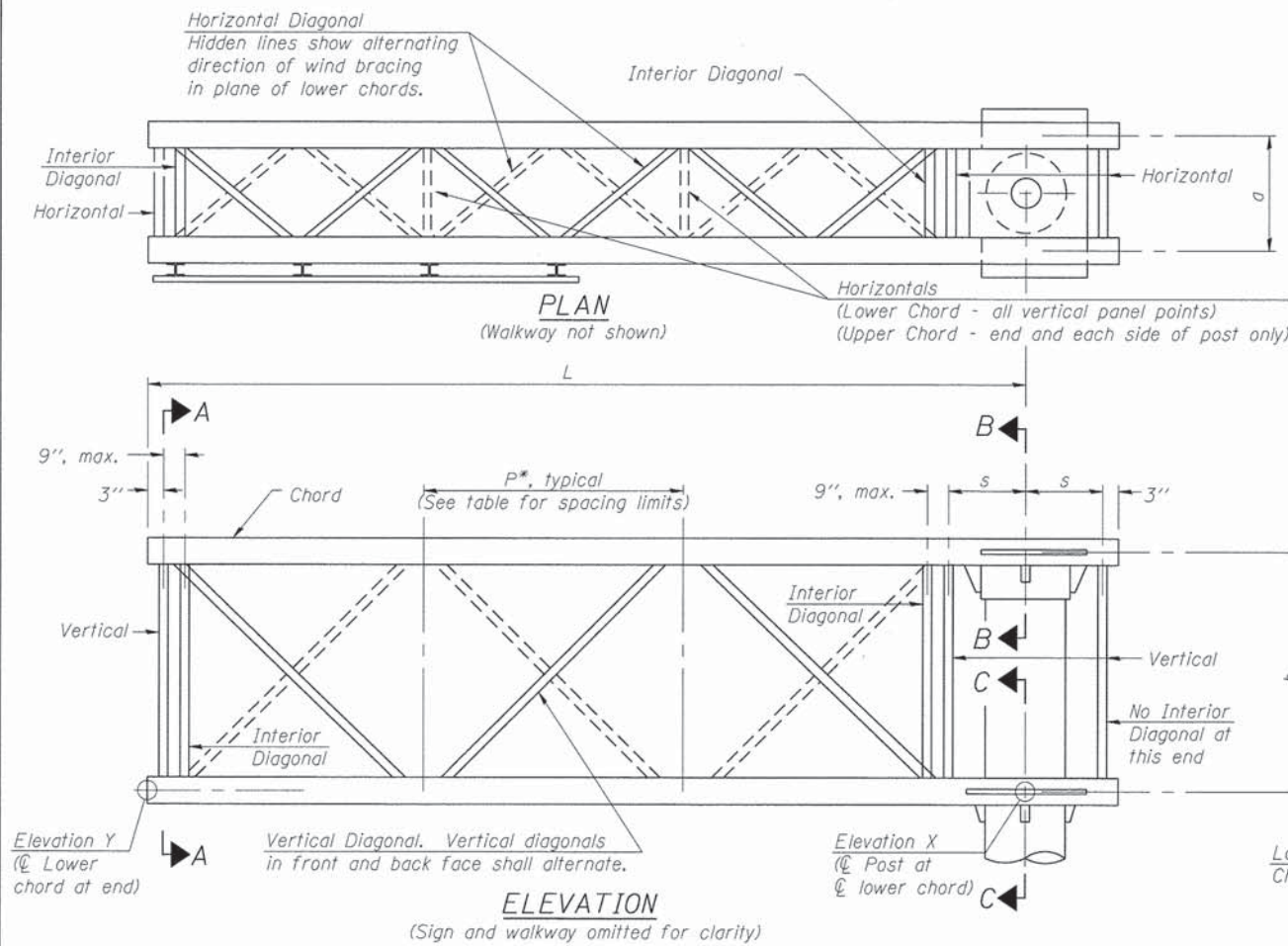

Note: For Section B-B and Section C-C, see Base Sheet OSC-A-3.  
There are twice as many horizontal diagonals as there are vertical diagonals.

**TRUSS UNIT TABLE**

Truss Type	Dimension "a"	Dimension "b"	Dimension "s"	Limits for Panel Spacing (P)*	Up. & Low. Chord		Verticals; Horizontals; Vertical, Horizontal, and Interior Diagonals	
					O.D.	Wall	O.D.	Wall
I-C-A	24"	54"	16"	36" min. to 48" max.	5"	5/16"	2 1/2"	5/16"
II-C-A	36"	66"	21"	42" min. to 54" max.	6 1/2"	5/16"	3 1/4"	5/16"
III-C-A (35' Max.)	36"	84"	21"	48" min. to 66" max.	7"	3/8"	3 1/2"	3/8"
III-C-A (>35' to 40')	36"	84"	21"	48" min. to 66" max.	8"	3/8"	3 1/2"	3/8"

$$*P = \frac{L - s - 3''}{\# \text{ Panels}}$$

Structure Number	Station	Truss Type	Design Length (L)	Number of Panels Per Unit	Panel Length (P)*
8C0821064R019.1	935+00	III-C-A	36'-0"	7	4'-10 1/2"
8C0821064R019.6	961+40	II-C-A	30'-0"	7	4'-0"
8C0821064R020.0	979+50	I-C-A	24'-6"	6	3'-10"

**SHOP CAMBER TABLE**

Unit Length (L)	Shop Camber at End
15'	1 1/2"
16'-17'	1 3/4"
18'-20'	2"
21'-22'	2 1/4"
23'-25'	2 1/2"
26'-27'	2 3/4"
28'-30'	3"
31'-32'	3 1/4"
33'-35'	3 1/2"
36'-37'	4"
38'-40'	4 1/2"

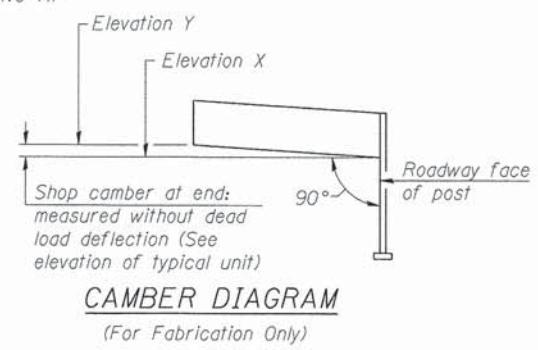
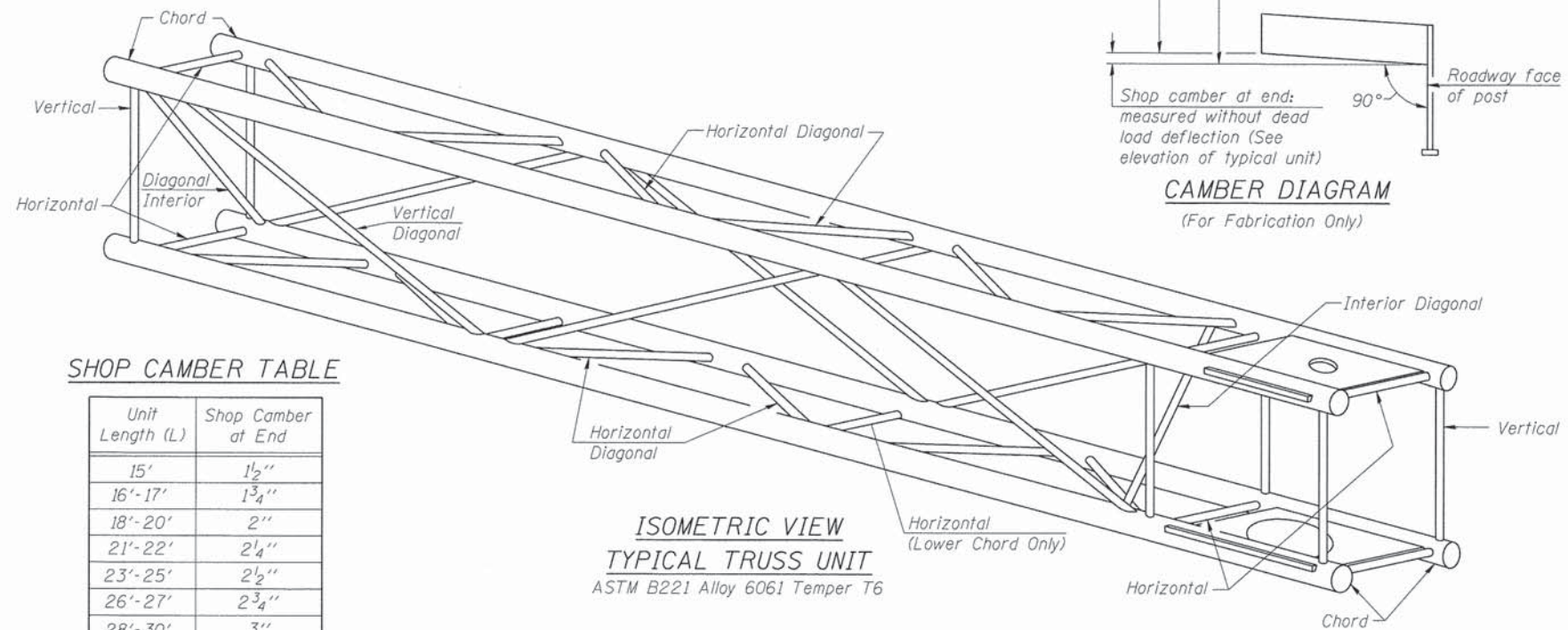

OSC-A-2

6-1-12

FILE NAME = 09-0016-shr-signcent82.dgn	USER NAME = IDOT	DESIGNED - JAH	REVISED -
MODEL NAME = Default	DRAWN - TJH	REVISOR -	REVISOR -
PLDT SCALE = 1/2" = 1' / ft.	CHECKED - LDC	REVISOR -	REVISOR -
PLDT DATE = 4/27/2014	DATE - Apr 29, 2014	REVISOR -	REVISOR -

STATE OF ILLINOIS  
DEPARTMENT OF TRANSPORTATION

CANTILEVER SIGN STRUCTURES - TRUSS DETAILS  
ALUMINUM TRUSS & STEEL POST

SCALE: SHEET NO. 2 OF 10 SHEETS STA. TO STA.

F.A.I. RTE.	SECTION	COUNTY	TOTAL SHEETS	SHEET NO.
64	09-00365-01-PV	ST. CLAIR	535	281
TR RTE. 222 (RIEDER ROAD)		CONTRACT NO. 97549		
ILLINOIS				

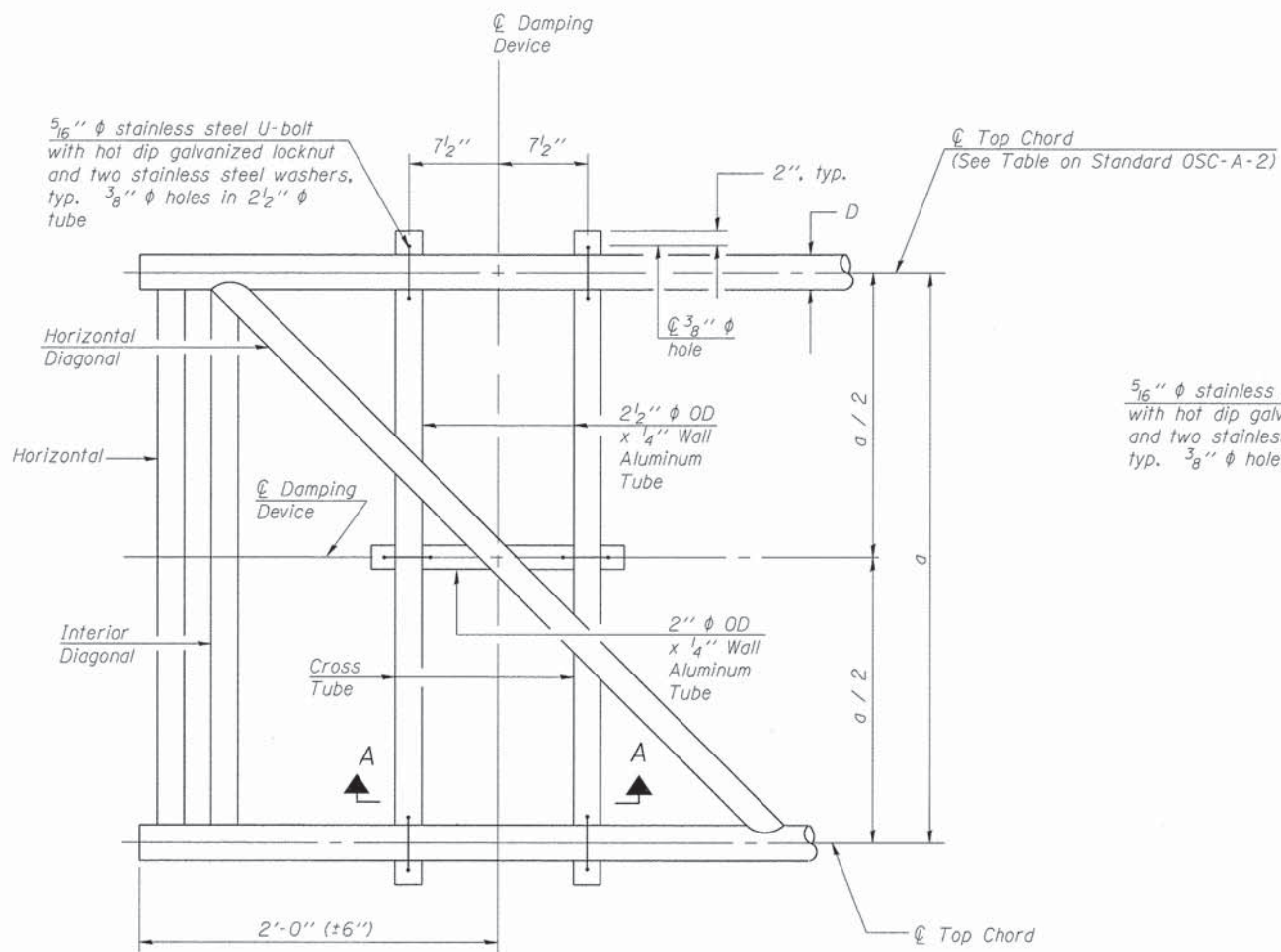

PLAN DETAIL

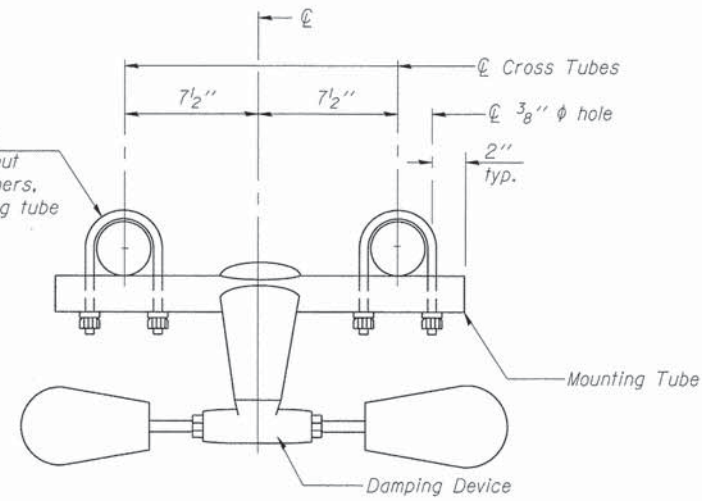

TRUSS DAMPING DEVICE CONNECTION DETAIL

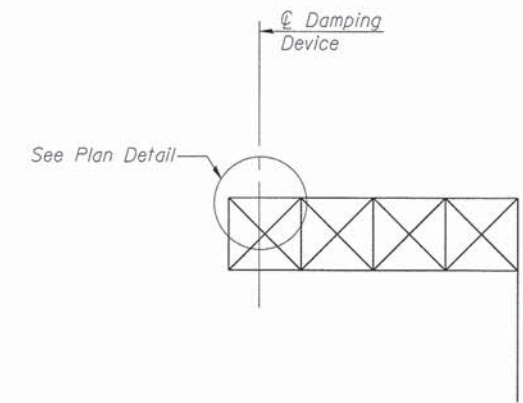

ELEVATION  
Aluminum Cantilever Sign Structure

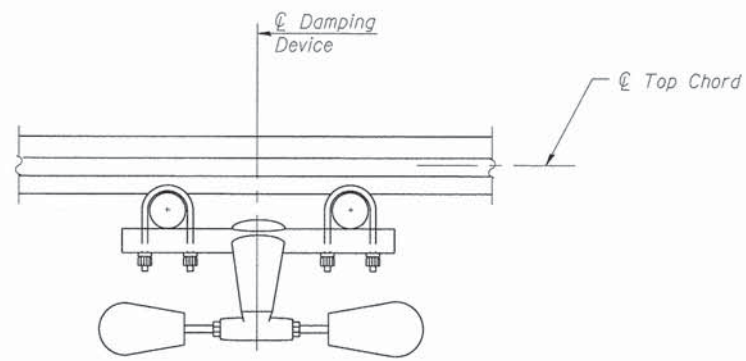

SECTION A-A

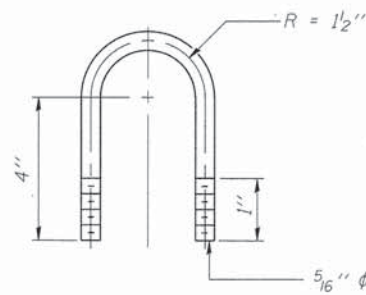

DAMPING DEVICE MOUNTING TUBE U-BOLT DETAIL  
(Typical)

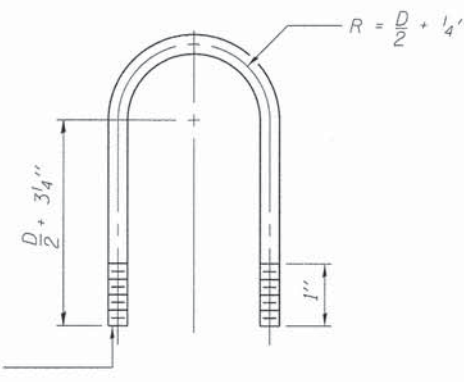

TOP CHORD TO CROSS TUBE U-BOLT DETAIL  
(Typical)

GENERAL NOTES

- Damper: One damper per truss. (31 lbs. Stockbridge-Type Aluminum-29" minimum between ends of weights)
- Materials: Aluminum tubes shall be ASTM B221 alloy 6061 temper T6

P:\09-0016\02 Render Road Phase 1\1\B\CAD\CADD Sheets\09-0016-sht-signcent03.dgn

OSC-A-D

6-1-12

USER NAME = 100T	DESIGNED - JAH	REVISED -
MODEL NAME = Default	DRAWN - TJH	REVISED -
PLOT SCALE = 12.0000' / ft	CHECKED - LDC	REVISED -
PLOT DATE = 4/27/2014	DATE - April 29, 2014	REVISED -

STATE OF ILLINOIS  
DEPARTMENT OF TRANSPORTATION

CANTILEVER SIGN STRUCTURE  
DAMPING DEVICE

SCALE: SHEET NO. 3 OF 10 SHEETS STA. TO STA.

F.A.I. RTE.	SECTION	COUNTY	TOTAL SHEETS	SHEET NO.
64	09-00365-01-PV	ST. CLAIR	535	282
TR RTE. 222 (RIEDER ROAD)			CONTRACT NO. 97549	
ILLINOIS				

Holes in galvanized steel post and aluminum collar = bolt  $\phi + \frac{1}{16}$ ".  
Holes in stainless steel sleeve = bolt  $\phi + \frac{3}{16}$ ".

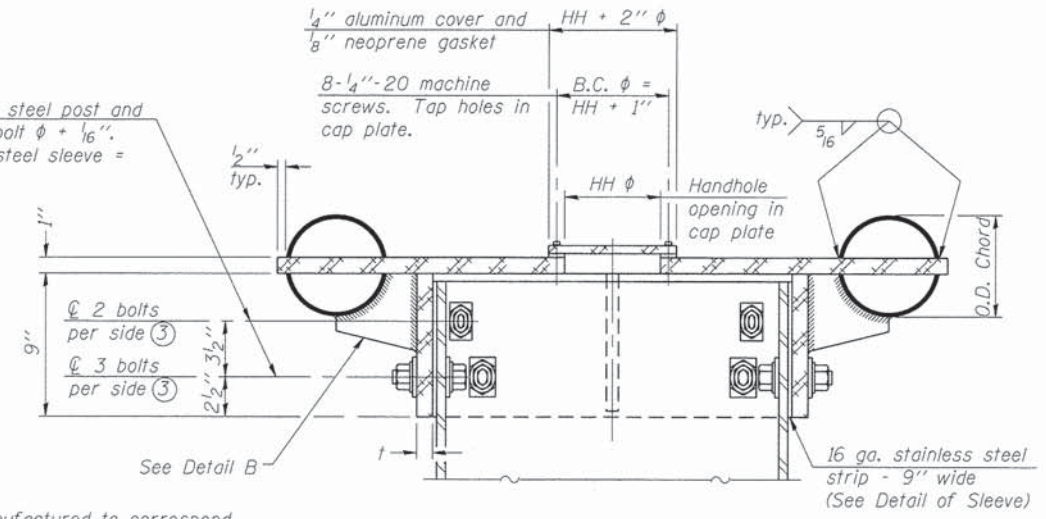

**SECTION B-B**  
Bolts, washers (including contoured washers), and locknuts shall be stainless steel.

④ Collar I.D. shall be manufactured to correspond to O.D. of actual galvanized post and stainless steel sleeve plus  $\frac{1}{8}$ " ( $\pm \frac{1}{16}$ "). Maximum gap between post and collar at any location equals  $\frac{1}{8}$ " before tightening bolts.

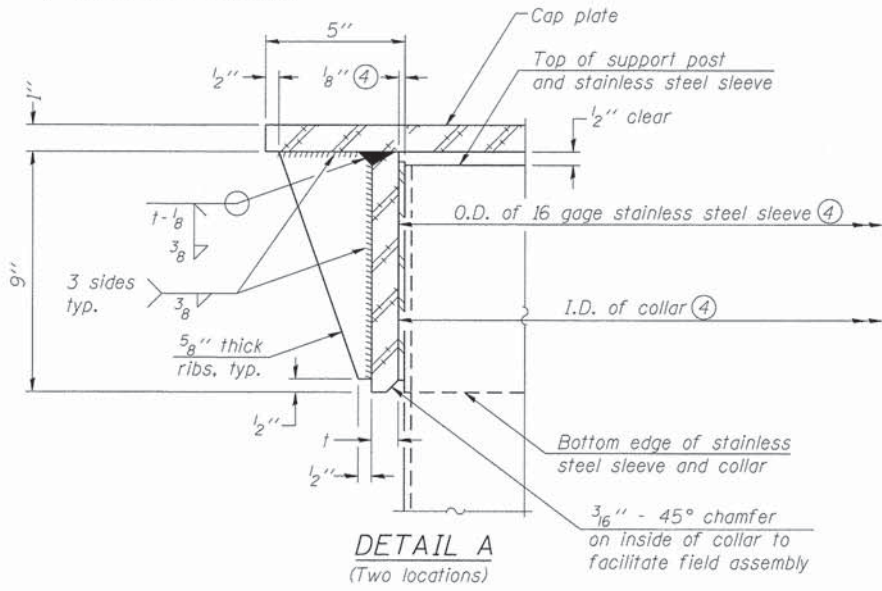

**DETAIL A**  
(Two locations)

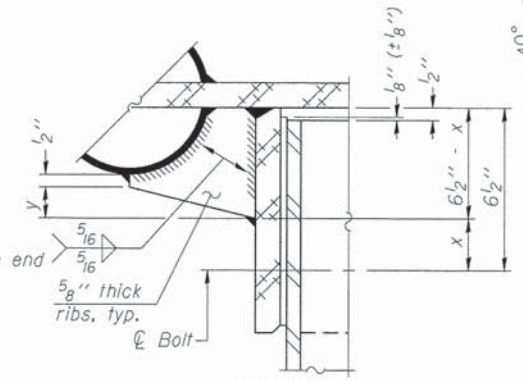

**DETAIL B**  
Two locations  
(For details not shown, see Detail C)

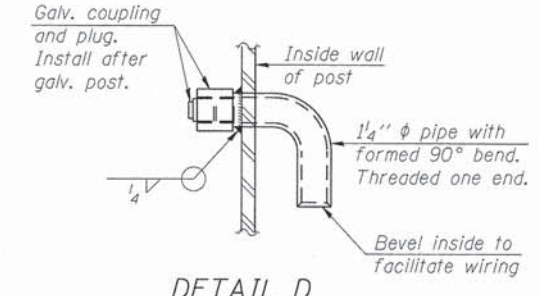

**DETAIL D**

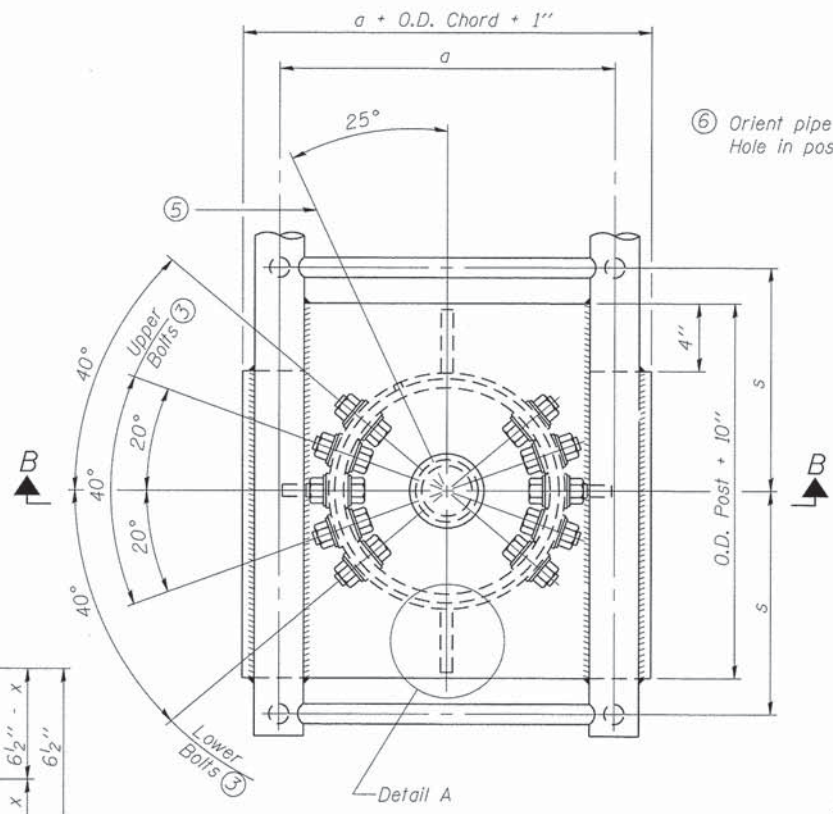

**PLAN VIEW - TOP OF COLUMN**

⑤ Optional full penetration weld in collar. (Two locations maximum....(180° apart)....X-ray or UT 100%)

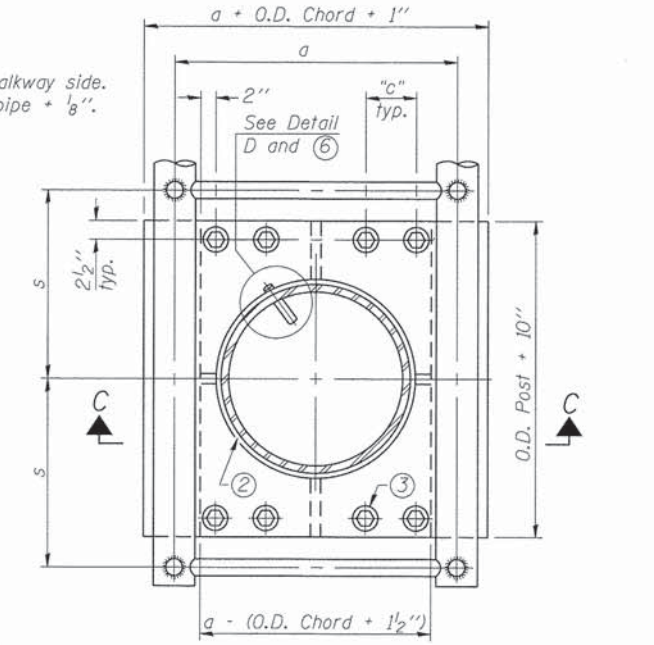

**SECTION THRU POST ABOVE LOWER CHORDS**

Hole in aluminum plate (and 16 ga. stnl. stl. sheet) to be O.D. post +  $\frac{1}{2}$ "

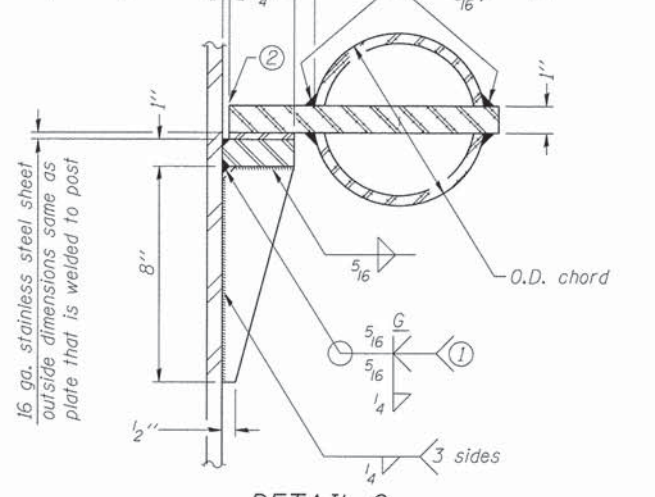

**DETAIL C**

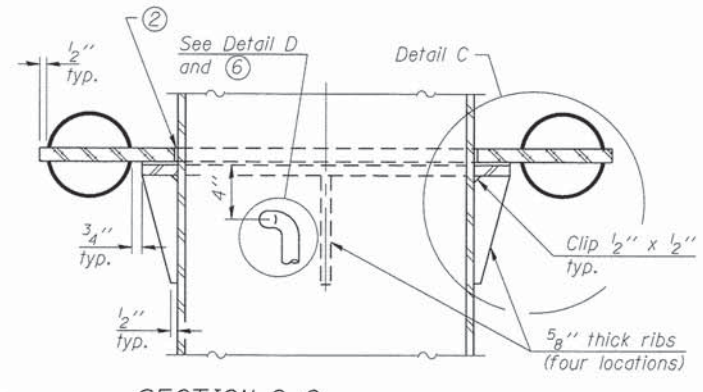

**SECTION C-C**

**CONTOURED WASHERS**

Bolt Size	Contoured Washers	
	Hole Dia.	B
7/8"	1"	2 1/2"
1"	1 1/8"	3"
1 1/4"	1 3/8"	3 1/4"

**DETAIL OF STAINLESS STEEL SLEEVE**

Weld to post after galvanizing. (Prepare post surface to insure tight, uniform fit and allow welding.) Welds to be 1/2" long at 6" cts. along top edge and at 1/4" opening.

Truss Type	Post Size	Upper & Lower Connection Bolt Diameter ③	Lower Juncture Bolt Spacing Dimension "c" ③	Opening in Cap Plate "HH"	Collar Thickness (t)	Side Ribs	
						x	y
I-C-A	16" $\phi$ (83#/')	7/8"	3 1/4"	8"	5/8"	1 3/4"	2 1/4"
II-C-A	24" $\phi$ (125#/')	1"	3 1/2"	12"	7/8"	2"	1 1/4"
III-C-A (35' max.)	24" $\phi$ (125#/')	1 1/4"	3 1/2"	12"	7/8"	2"	1"
III-C-A (>35' to 40')	24" $\phi$ (171#/')	1 1/4"	3 1/2"	12"	7/8"	2"	1"

- ① Grind top if required to fully seat aluminum plate and stainless steel sheet.
- ② After tightening lower connection bolts, fill gap with non-hardening, silicone caulk suitable for exterior exposure and acceptable to the Engineer. Cost is included in Overhead Sign Structure Cantilever.
- ③ Upper and lower connection bolts in collar and bolts at lower chord connection shall be high strength with matching locknuts. Connection bolts shall have 2 stainless steel flat washers each.

OSC-A-3

6-1-12

FILE NAME = 09-0016-sht-signcant04.dgn	USER NAME = IDOT	DESIGNED - JAH	REVISED -
MODEL NAME = Default	DRAWN - TJH	CHECKED - LDC	REVISED -
PLOT SCALE = 12.0000' / ft.	DATE - Apr 29, 2014		REVISED -
PLOT DATE = 4/27/2014			

STATE OF ILLINOIS  
DEPARTMENT OF TRANSPORTATION

CANTILEVER SIGN STRUCTURES - JUNCTURE DETAILS  
ALUMINUM TRUSS & STEEL POST

F.A.I. RTE.	SECTION	COUNTY	TOTAL SHEETS	SHEET NO.
64	09-00365-01-PV	ST. CLAIR	535	283
TR RTE. 222 (RIEDER ROAD)		CONTRACT NO. 97549		
ILLINOIS				

SCALE: SHEET NO. 4 OF 10 SHEETS STA. TO STA.

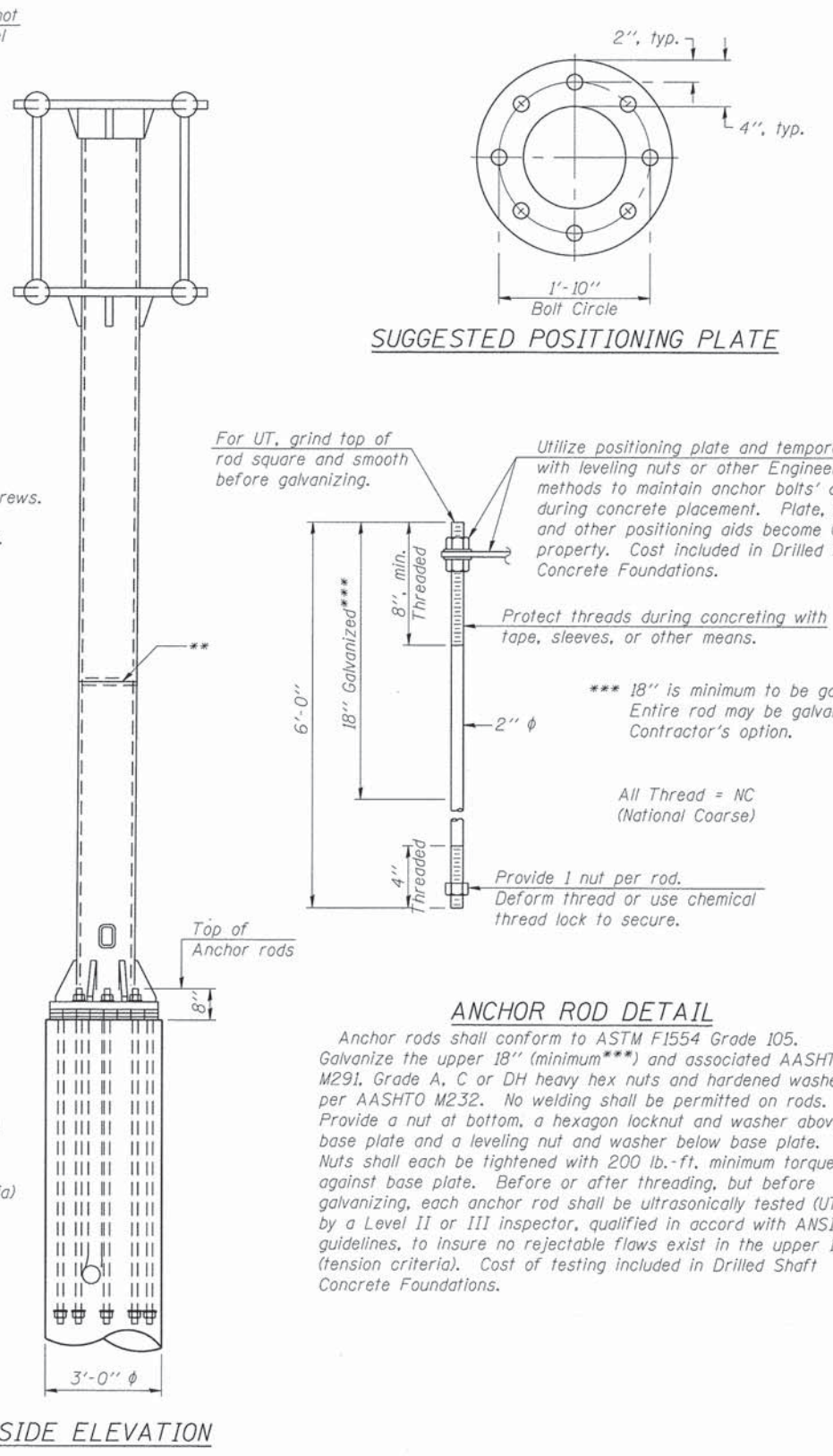
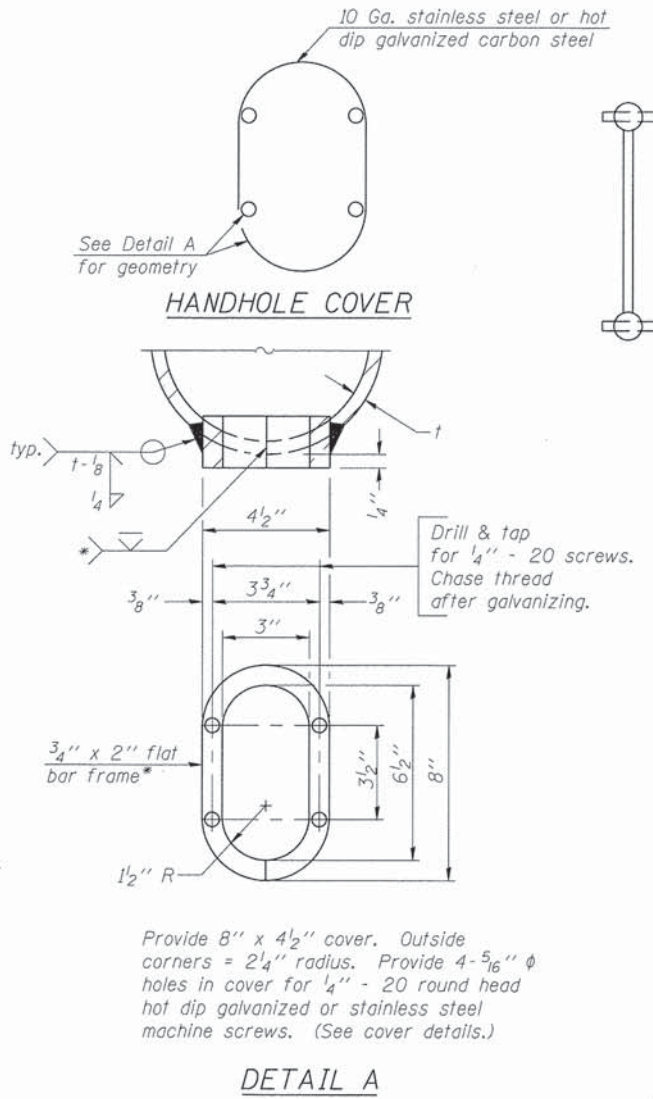
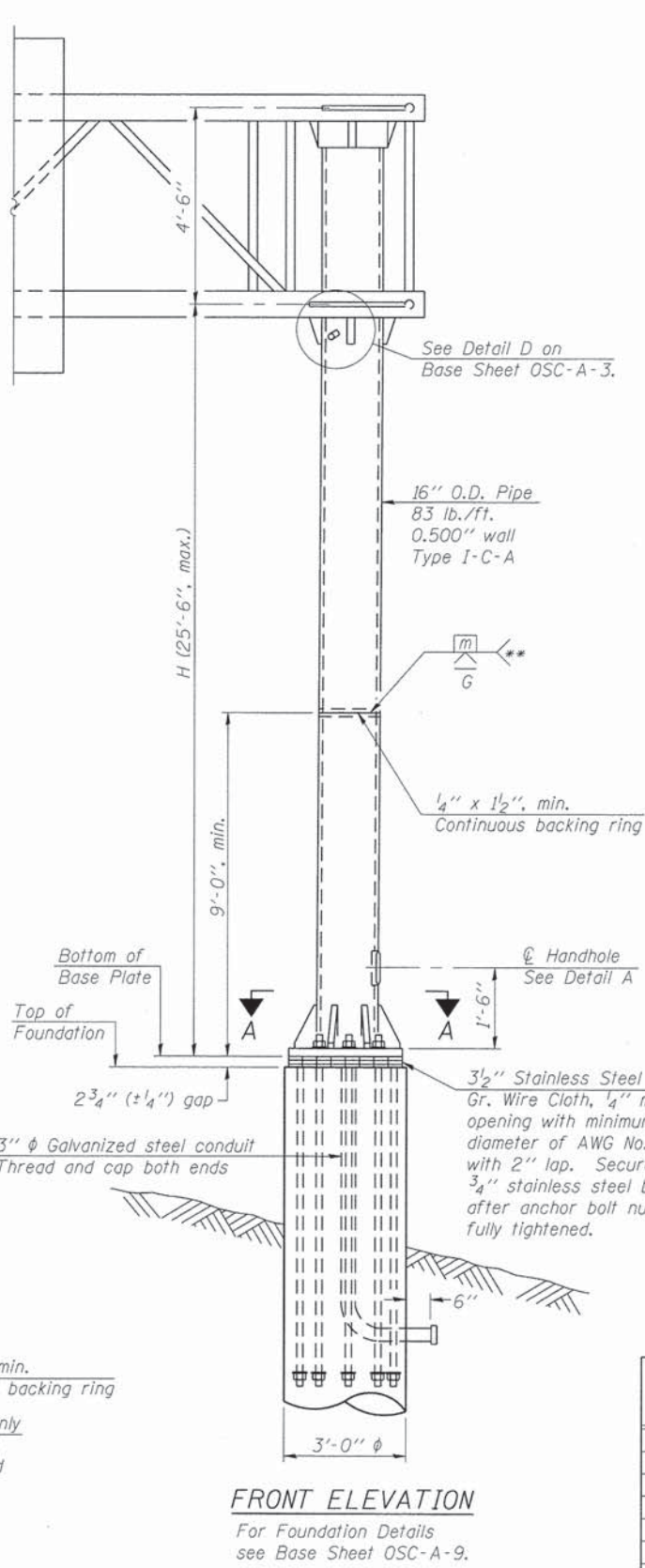
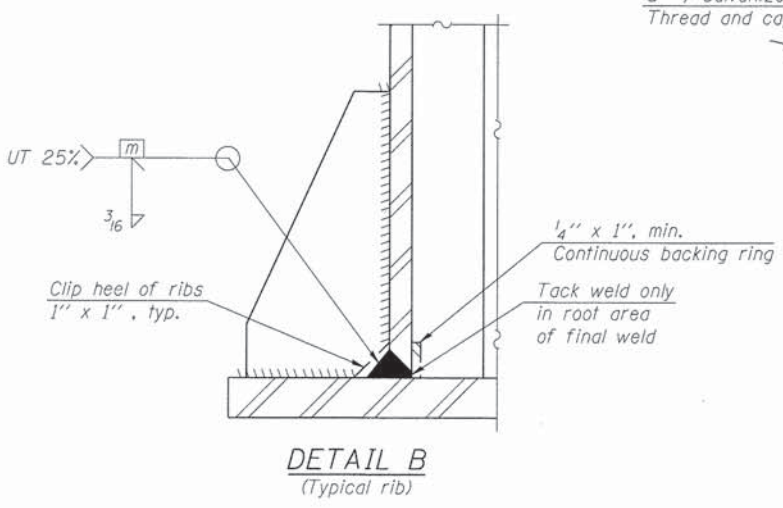
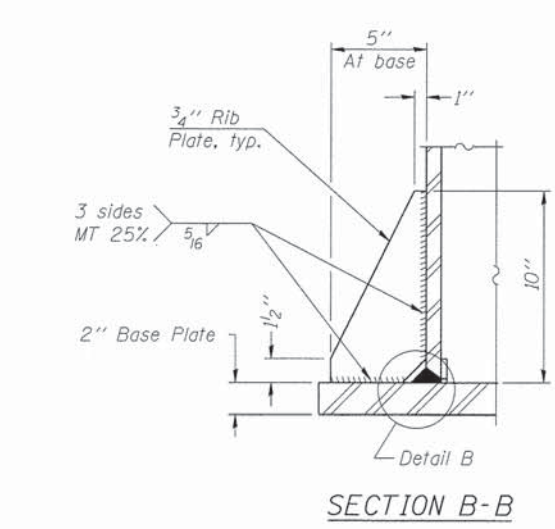
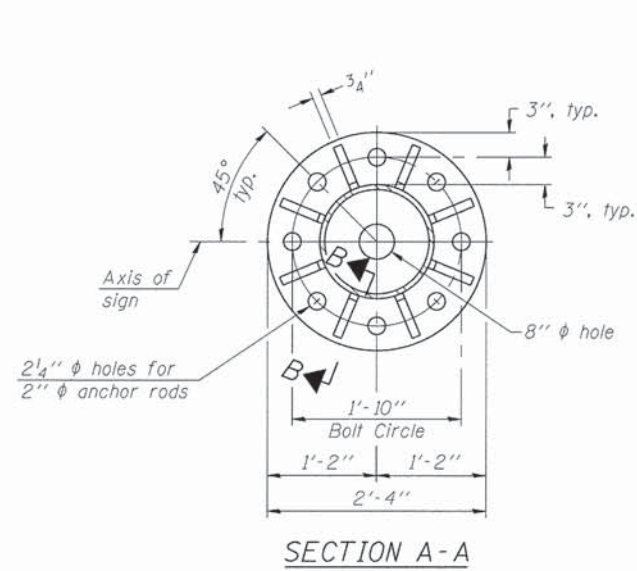

\* Bent bars may be butt welded top and bottom or bottom only. In lieu of fabricated handhole frame as shown, may cut from 2" plate (rolling direction vertical). All cut faces to be ground to ANSI Roughness of 500  $\mu$ in or less.

\*\* Butt welded joint in post is only allowed for post heights (H) over 20 ft. in length. If used, weld procedure must be preapproved by Engineer and joint shall receive 100% RT or UT (tension criteria) at Contractor's expense.

Structure Number	Station	H
8C0821064R020.0	979+50	22'-3"

Note: "H" based on 15'-0" or actual sign height, whichever is greater.

OSC-A-4

6-1-12

FILE NAME = 09-0816-ah-signcant05.dgn	USER NAME = IDOT	DESIGNED - JAH	REVISED -
MODEL NAME = Default	DRAWN - TJH	REVISIONS -	
PLDT SCALE = 12,0000 ' / ft.	CHECKED - LDC	REVISIONS -	
PLDT DATE = 4/27/2014	DATE - Apr 29, 2014	REVISIONS -	

STATE OF ILLINOIS  
DEPARTMENT OF TRANSPORTATION

CANTILEVER SIGN STRUCTURES - TYPE I-C-A TRUSS  
SUPPORT POST - ALUMINUM TRUSS & STEEL POST

SCALE: SHEET NO. 5 OF 10 SHEETS STA. TO STA.

F.A.I. RTE.	SECTION	COUNTY	TOTAL SHEETS	SHEET NO.
64	09-00365-01-PV	ST. CLAIR	535	284
TR RTE. 222 (RIEDER ROAD)		CONTRACT NO. 97549		(ILLINOIS)

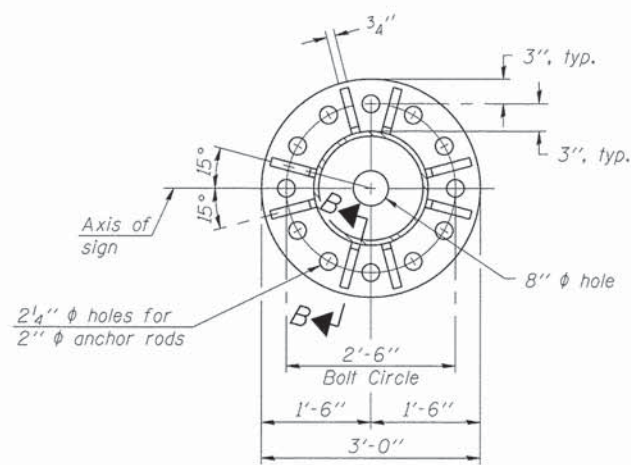

SECTION A-A

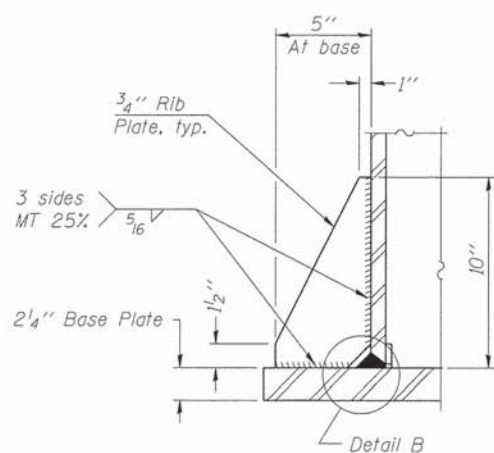

SECTION B-B

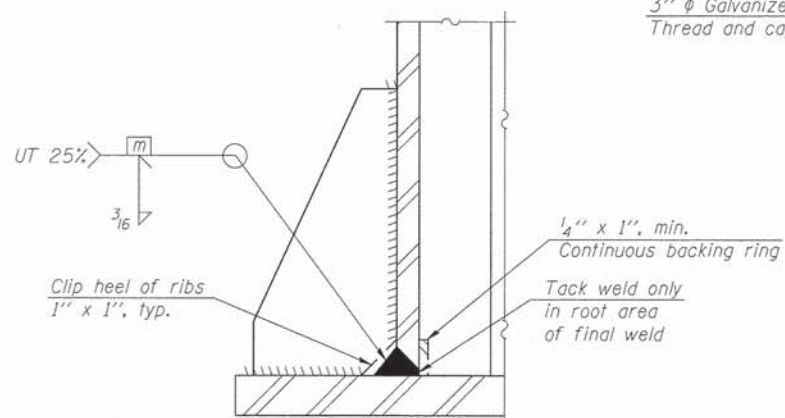

DETAIL B  
(Typical rib)

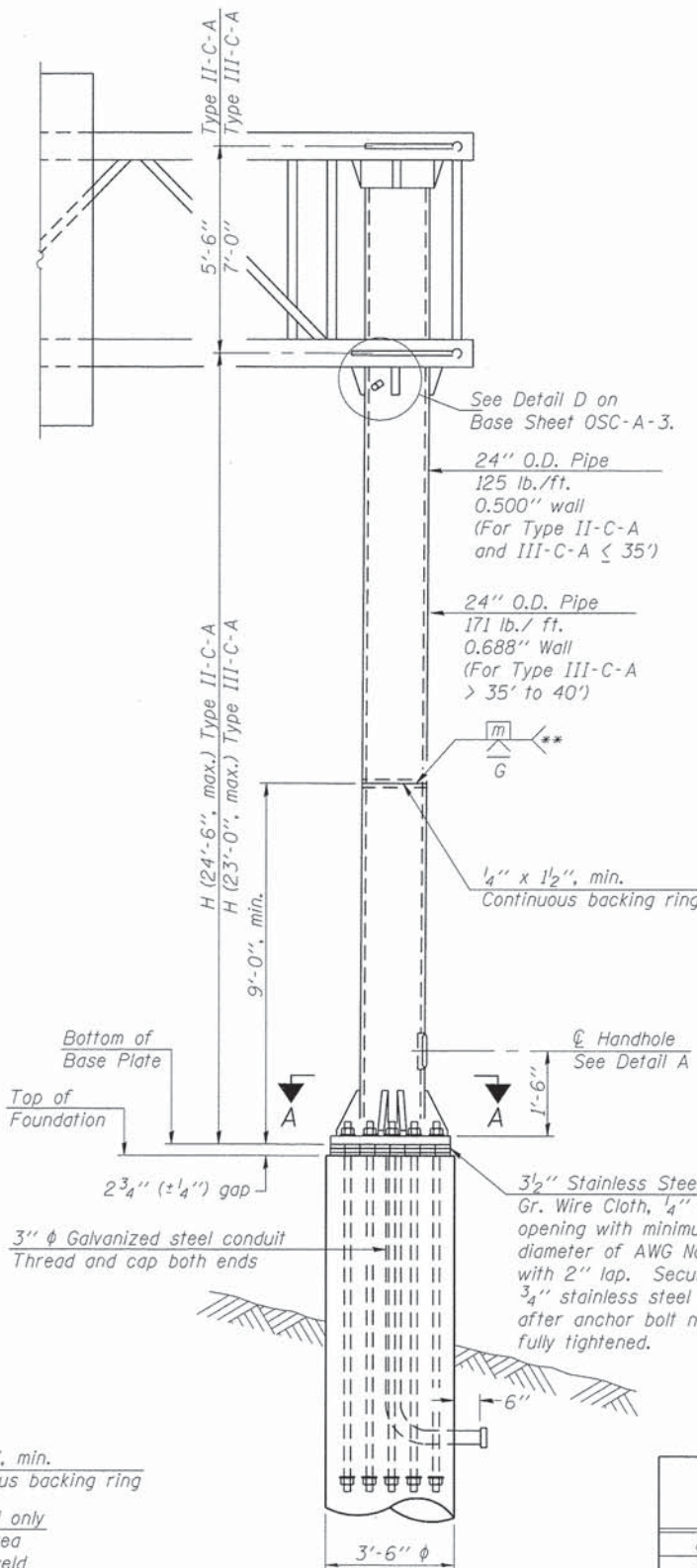

FRONT ELEVATION  
For Foundation Details  
see Base Sheet OSC-A-9.

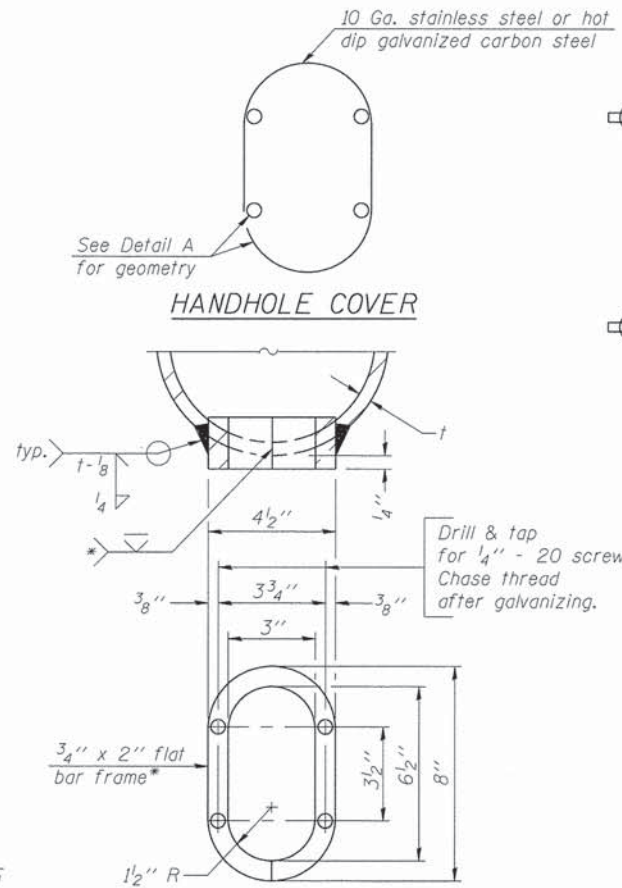

DETAIL A

- \* Bent bars may be butt welded top and bottom or bottom only. In lieu of fabricated handhole frame as shown, may cut from 2" plate (rolling direction vertical). All cut faces to be ground to ANSI Roughness of 500 μin or less.
- \*\* Butt welded joint in post is only allowed for post heights (H) over 20 ft. in length. If used, weld procedure must be preapproved by Engineer and joint shall receive 100% RT or UT (tension criteria) at Contractor's expense.

Structure Number	Station	H
8C0821064R019.1	935+00	22'-0"
8C0821064R019.6	961+40	23'-0"

Note: "H" based on 15'-0" or actual sign height, whichever is greater.

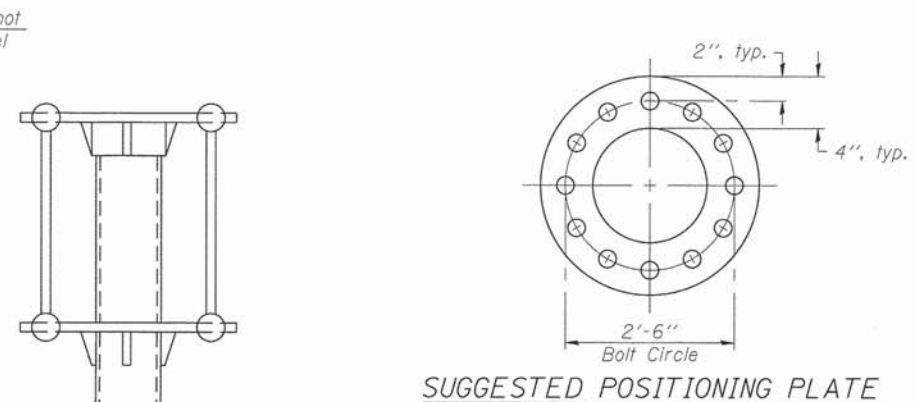

SUGGESTED POSITIONING PLATE

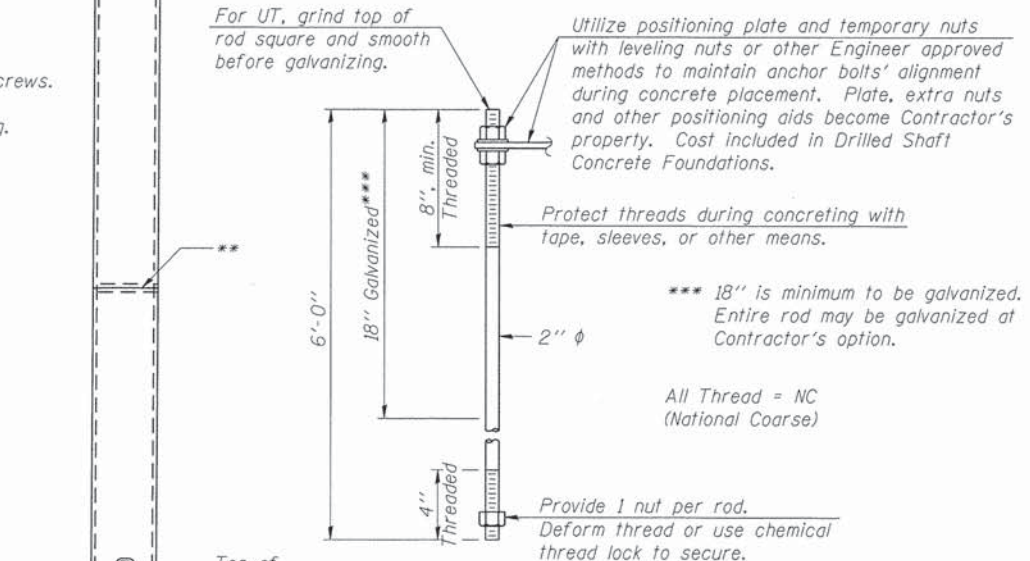

ANCHOR ROD DETAIL

Anchor rods shall conform to ASTM F1554 Grade 105. Galvanize the upper 18" (minimum) and associated AASHTO M291, Grade A, C or DH heavy hex nuts and hardened washers per AASHTO M232. No welding shall be permitted on rods. Provide a nut at bottom, a hexagon locknut and washer above base plate and a leveling nut and washer below base plate. Nuts shall each be tightened with 200 lb.-ft. minimum torque against base plate. Before or after threading, but before galvanizing, each anchor rod shall be ultrasonically tested (UT) by a Level II or III inspector, qualified in accord with ANSI guidelines, to insure no rejectable flaws exist in the upper 18" (tension criteria). Cost of testing included in Drilled Shaft Concrete Foundations.

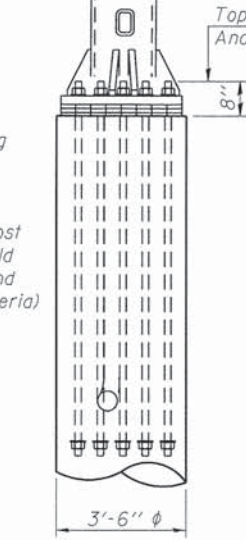

SIDE ELEVATION

OSC-A-5

6-1-12

FILE NAME = 09-0016-sht-signcant06.dgn	USER NAME = IDOT	DESIGNED - JAH	REVISED -
MODEL NAME = Default	DRAWN - TJH	CHECKED - LDC	REVISED -
PLOT SCALE = 12.0000' / ft.	DATE = Apr 11 29, 2014		
PLOT DATE = 4/27/2014			

STATE OF ILLINOIS  
DEPARTMENT OF TRANSPORTATION

CANTILEVER SIGN STRUCTURES - TYPE II-C-A & III-C-A  
TRUSS SUPPORT POST - ALUMINUM TRUSS & STEEL POST

SCALE: SHEET NO. 6 OF 10 SHEETS STA. TO STA.

F.A.I. RTE.	SECTION	COUNTY	TOTAL SHEETS	SHEET NO.
64	09-00365-01-PV	ST. CLAIR	535	285
TR RTE. 222 (RIEDER ROAD)			CONTRACT NO. 97549	
ILLINOIS				

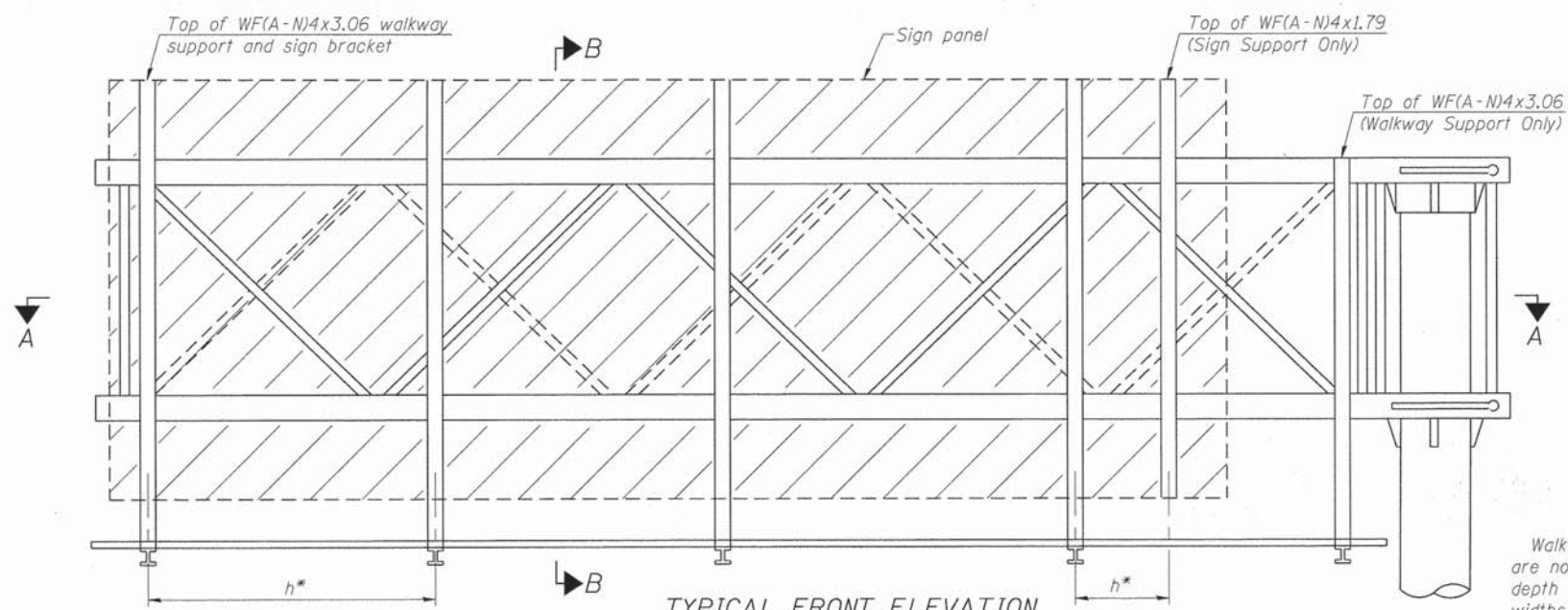

**TYPICAL FRONT ELEVATION**  
With lights and handrail omitted for clarity.

Walkway and truss grating dimensions are nominal and may vary (width ±1/2", depth ±1/2") based on available standard widths.

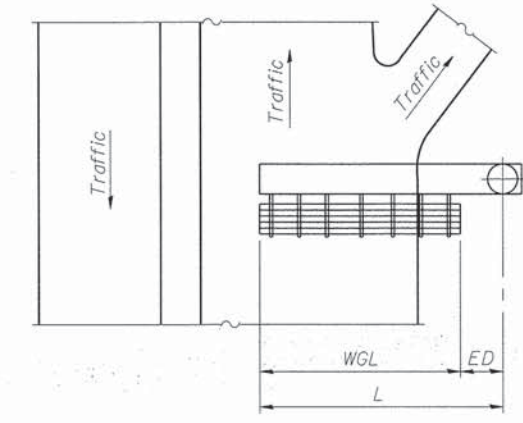

**PLAN WALKWAY AND HANDRAIL SKETCH**  
(Road plan beneath truss varies)

Structure Number	Station	WGL	ED	TGL
8C0821064R019.1	935+00	23'-0"	13'-0"	34'-6"
8C0821064R019.6	961+40	16'-6"	13'-6"	28'-6"
8C0821064R020.0	979+50	16'-6"	8'-0"	23'-4"

**Notes:**  
 \* Space walkway brackets WF(A-N)4x3.06 and sign brackets WF(A-N)4x1.79 for efficiency and within limits shown:  
 f = 12" maximum, 4" minimum (End of sign to center of nearest bracket)  
 g = 12" maximum, 4" minimum (End of walkway to center of nearest bracket)  
 h = 6'-0" maximum (center to center sign and/or walkway support brackets, WF(A-N)4x1.79 or WF(A-N)4x3.06)  
 \*\*\* If walkway bracket at safety chain location is behind sign, add angle to bracket. See alternate safety chain attachment on base sheet OSC-A-8  
 For details of sign placement, sign/walkway brackets, truss and walkway gratings, grating splices and Section B-B, see Base Sheet OSC-A-7.  
 For details of handrail, handrail joint, safety chain and Details F and G, see Base Sheet OSC-A-8.

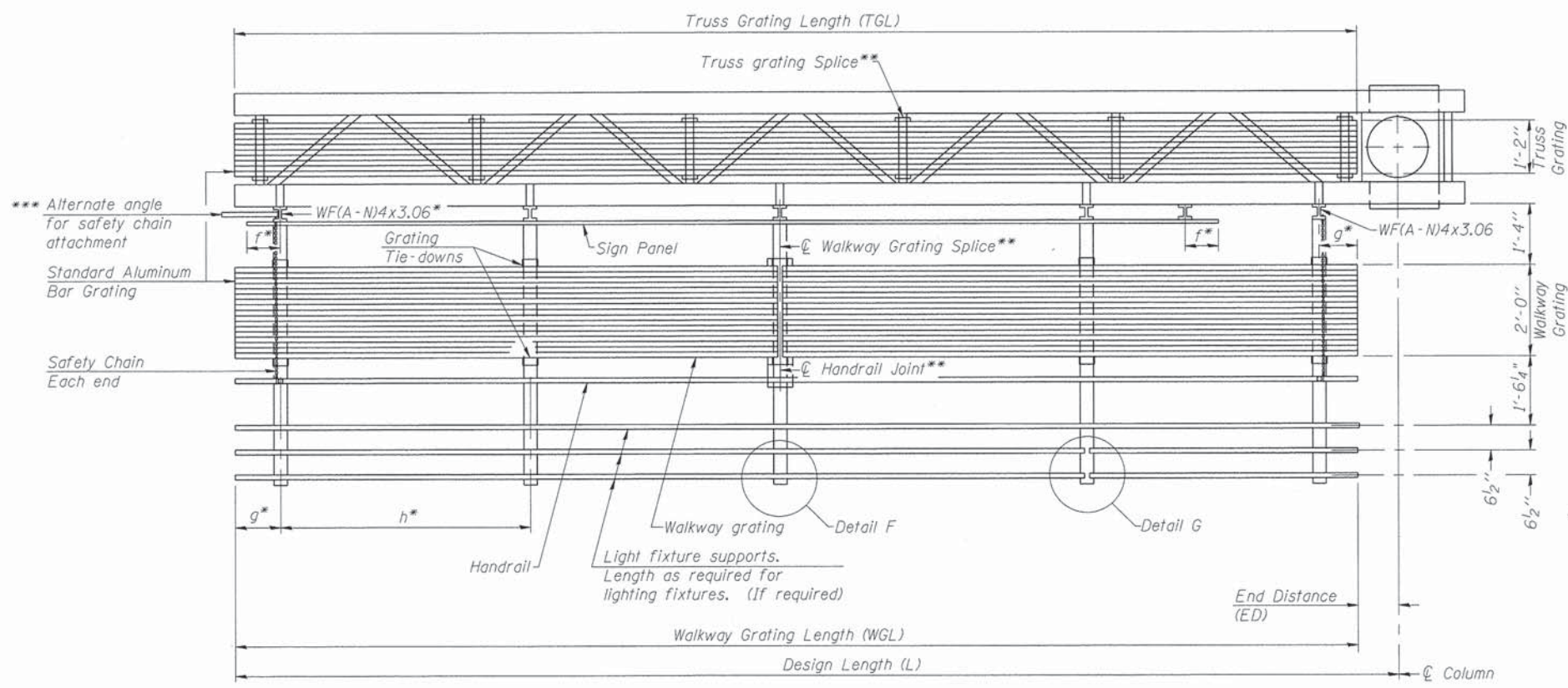

**SECTION A-A**

Truss grating to facilitate inspection shall run full length of cantilevers. Cost of truss grating is included in Overhead Sign Structure Cantilever.

Handrail and walkway grating shall span a minimum of three brackets between splices.  
 \*\* Use and location of handrail joints or grating splices are optional, based on lengths needed and material availability.

$$TGL = L - \left( \frac{\text{Post O.D.}}{2} + 6'' \right)$$

**BRACKET TABLE**

Sign Width		Number Brackets Required
Greater Than	Less Than or Equal To	
	8'-0"	2
8'-0"	14'-0"	3
14'-0"	20'-0"	4
20'-0"	26'-0"	5
26'-0"	32'-0"	6

P:\95-2016\02 Reader Road Phase 1\11\11\_C001\_C000\_Sheets\09-001E-sht-signcant07.dgn

OSC-A-6

6-1-12

FILE NAME = 09-2016-sht-signcant07.dgn

USER NAME = IDOT	DESIGNED - JAH	REVISED -
MODEL NAME = Default	DRAWN - TJH	REVISED -
PLOT SCALE = 12.0000' / Ft.	CHECKED - LDC	REVISED -
PLOT DATE = 4/27/2014	DATE - April 29, 2014	REVISED -

**STATE OF ILLINOIS  
DEPARTMENT OF TRANSPORTATION**

**CANTILEVER SIGN STRUCTURES - ALUMINUM WALKWAY  
DETAILS - ALUMINUM TRUSS & STEEL POST**

SCALE: SHEET NO. 7 OF 10 SHEETS STA. TO STA.

F.A.I. RTE.	SECTION	COUNTY	TOTAL SHEETS	SHEET NO.
64	09-00365-01-PV	ST. CLAIR	535	286
TR RTE. 222 (RIEDER ROAD)			CONTRACT NO. 97549	
ILLINOIS				



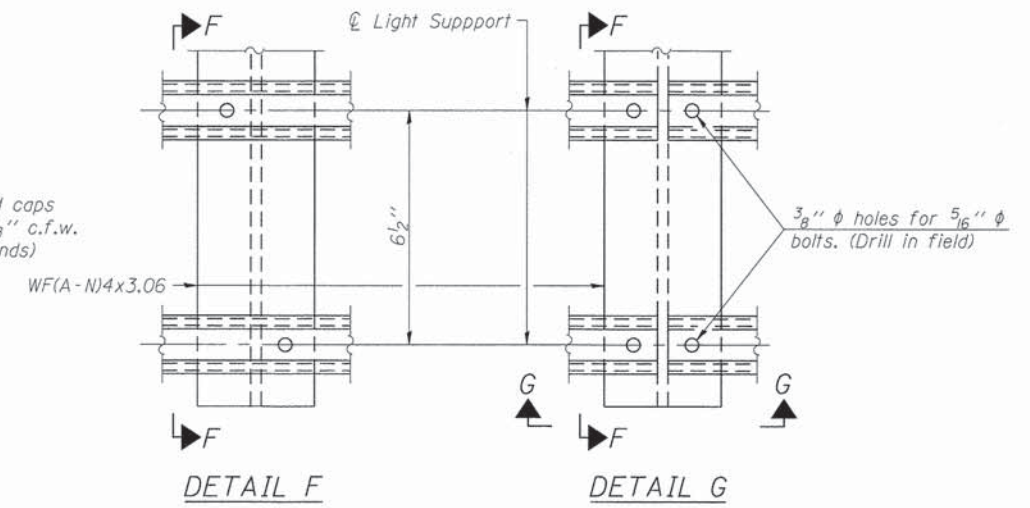
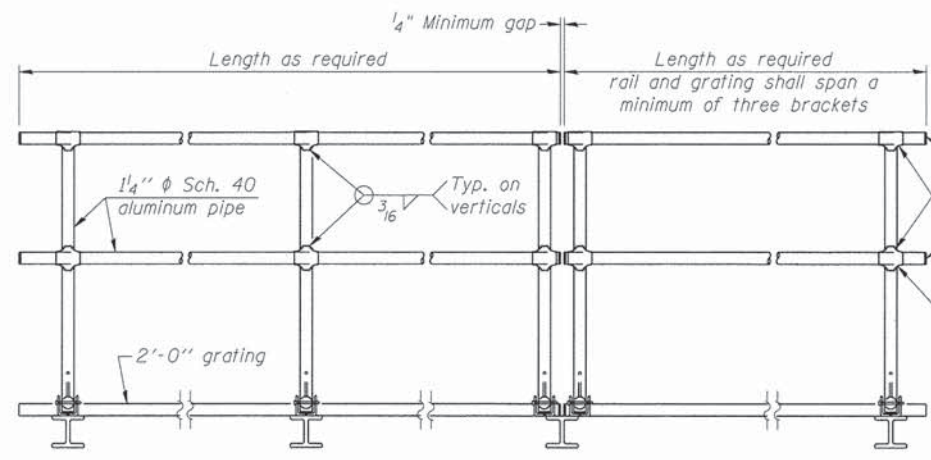
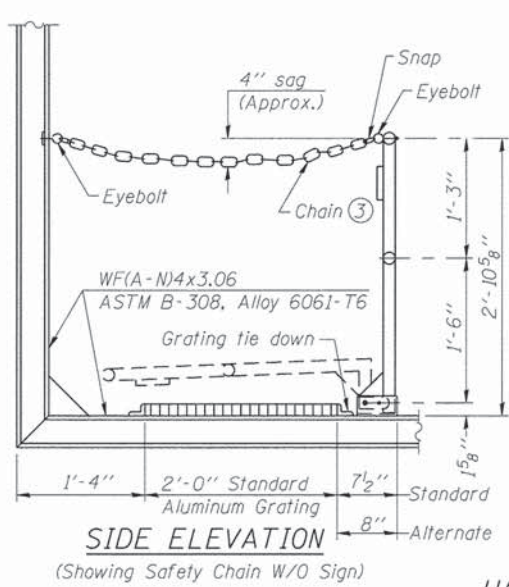

**SIDE ELEVATION**  
(Showing Safety Chain W/O Sign)

**FRONT ELEVATION**

**DETAIL F**

**DETAIL G**

**HANDRAIL DETAILS**

Handrail pipe shall be ASTM B241 or B429, Alloy 6063-T6 or Alloy 6061-T6.

② Horizontal handrail member shall be continuous thru fitting. Provide 7/16" φ hole in fitting for 3/8" φ bolt. Field drill 7/16" φ hole in horizontal rail member. Provide locknut and two stainless steel washers for bolt. (Use 5/16" eyebolts in 7/16" φ holes on top rail at ends only.)

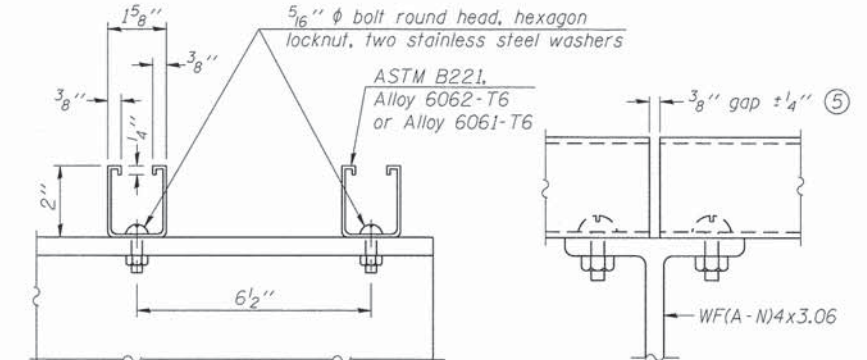
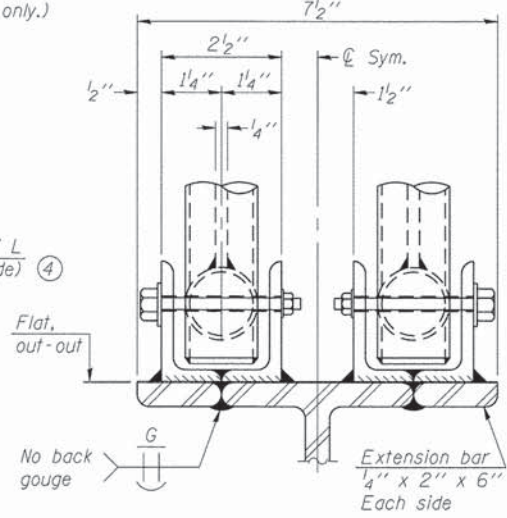
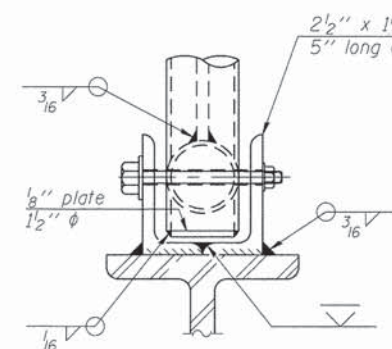
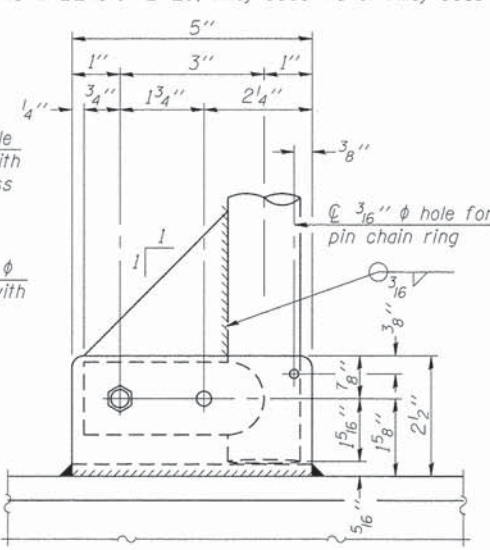
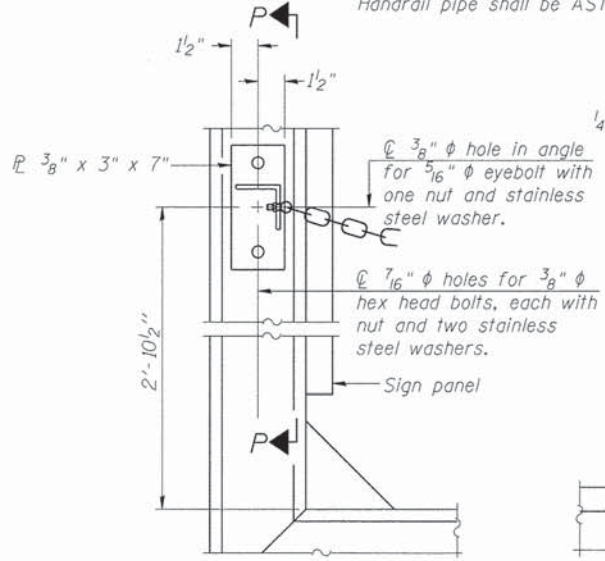

**SECTION F-F**

**SECTION G-G**

**LIGHTING FIXTURE MOUNTS (IF REQUIRED)**

⑤ Field cut ends of light support channels shall be free of burrs or hazardous projections and coated with zinc-rich primer or equivalent.

**ALTERNATE SAFETY CHAIN ATTACHMENT**

(With Sign Present)  
Items not shown same as "Side Elevation" of "Handrail Details"

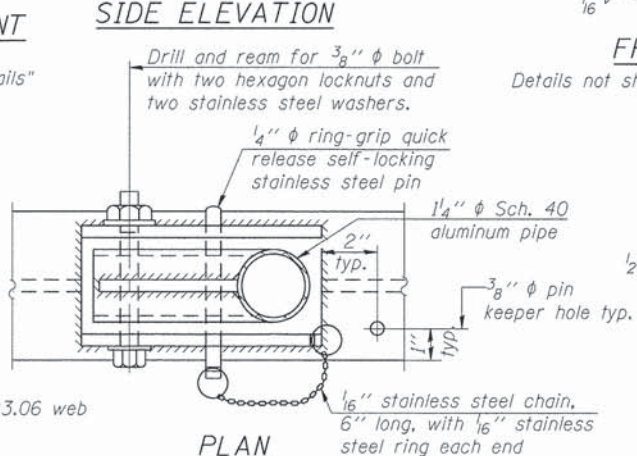
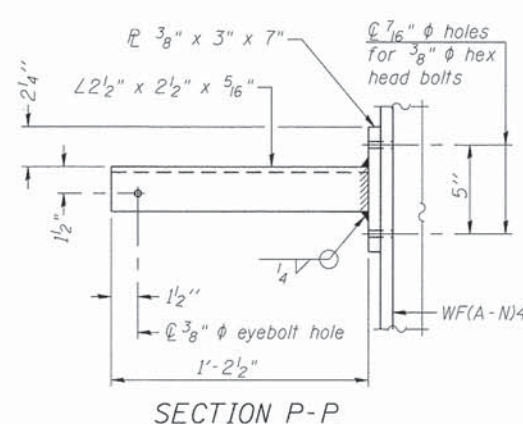

**PLAN**  
**DETAIL E HANDRAIL HINGE**

Details not shown same as "ELEVATION" at right.

**FRONT ELEVATION**

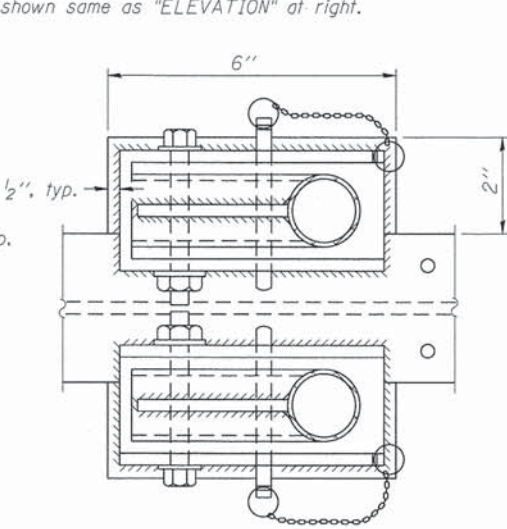

**PLAN AT HANDRAIL JOINT**  
Details not shown same as "PLAN"

**ELEVATION AT HANDRAIL JOINT** ④

Details not shown same as "FRONT ELEVATION"

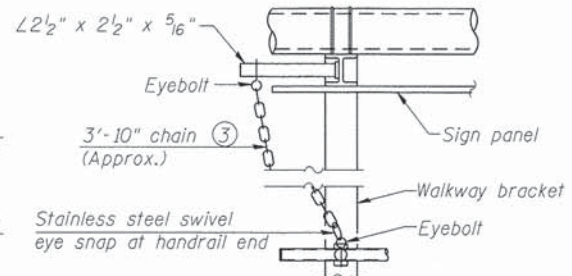

**ALTERNATE SAFETY CHAIN ATTACHMENT**

Details not shown similar to "Safety Chain" Details (Walkway omitted for clarity)

③ 3/16" Type 304L stainless steel chain, approximately 12 links per foot.

④ Extrusions may be used in lieu of the details shown, with approval of the Engineer.

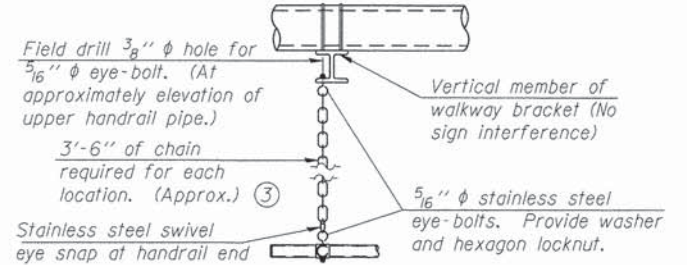

**SAFETY CHAIN**

One required for each end of each walkway.

OSC-A-8

6-1-12

FILE NAME = 09-0016-sht-signcent09.dgn	USER NAME = IDDT	DESIGNED - JAH	REVISED -	STATE OF ILLINOIS DEPARTMENT OF TRANSPORTATION	CANTILEVER SIGN STRUCTURES - HANDRAIL DETAILS ALUMINUM TRUSS & STEEL POST	F.A.I. RTE. 64	SECTION 09-00365-01-PV	COUNTY ST. CLAIR	TOTAL SHEETS 535	SHEET NO. 288	
	MODEL NAME = Default	DRAWN - TJH	REVISED -			SCALE:	SHEET NO. 9 OF 10 SHEETS	TR RTE. 222 (RIEDER ROAD)	CONTRACT NO. 97549	ILLINOIS	
	PLOT SCALE = 12,0000' / ft.	CHECKED - LDC	REVISED -								
	PLOT DATE = 4/27/2014	DATE - April 29, 2014	REVISED -								



\* Grind anchor rod to bright finish at ground clamp location before installing clamp.

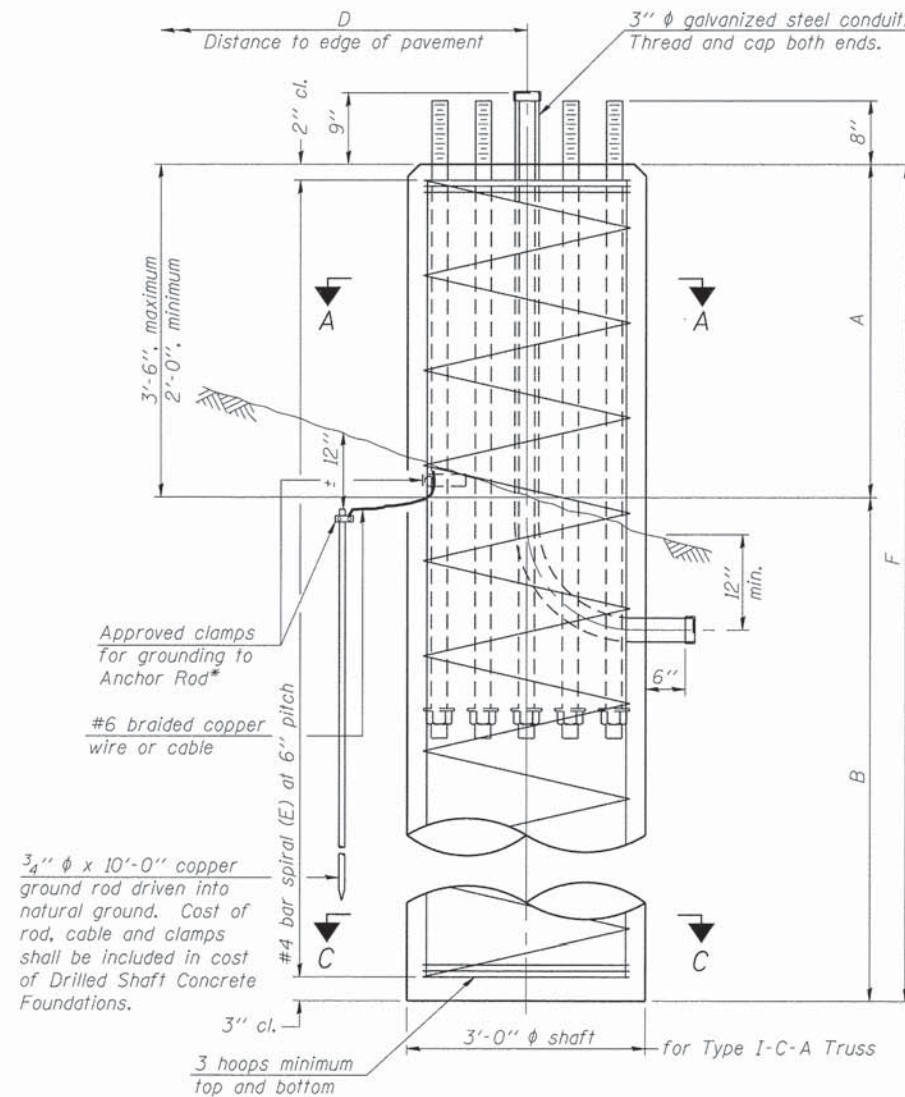

ELEVATION

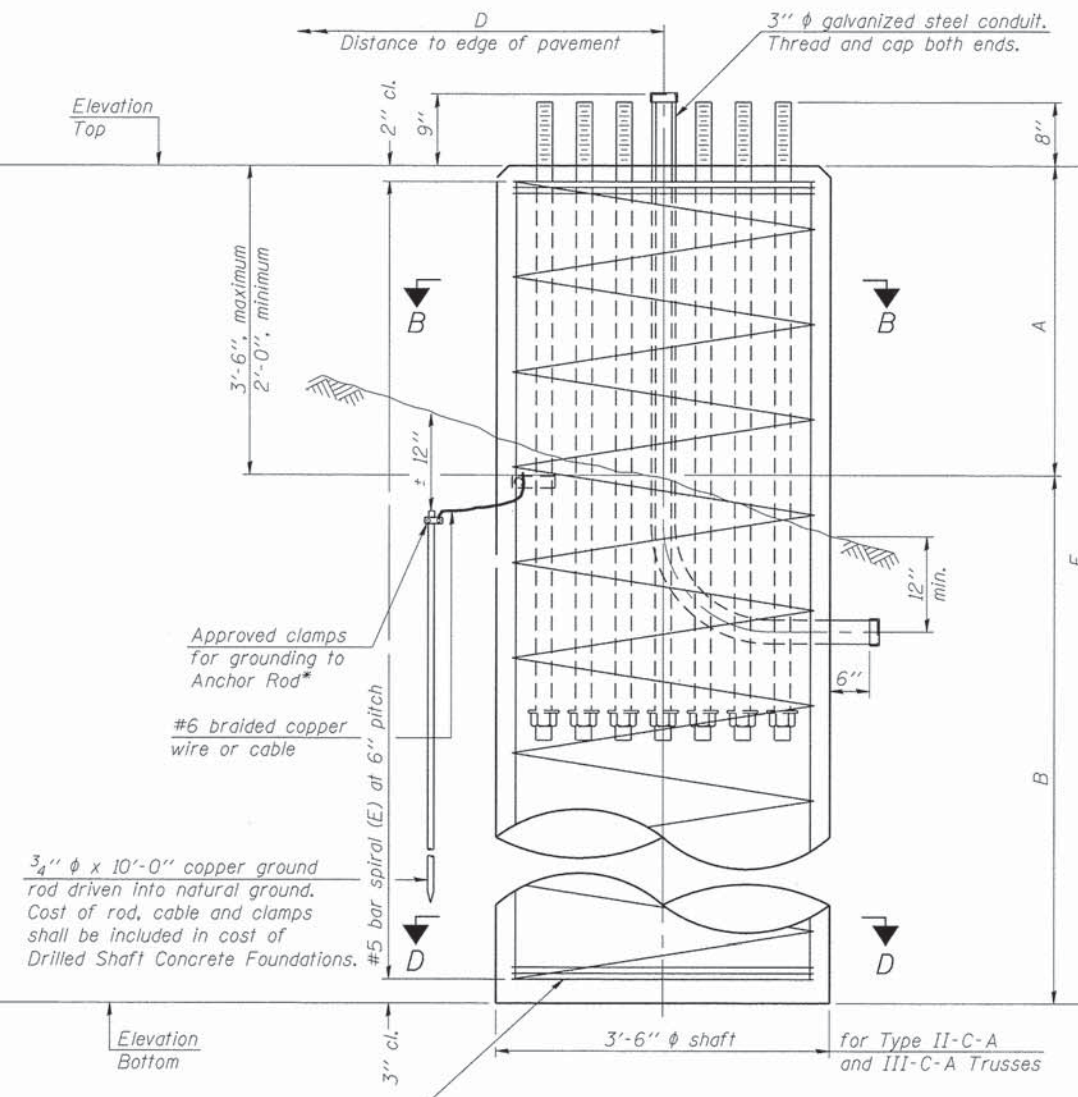

ELEVATION

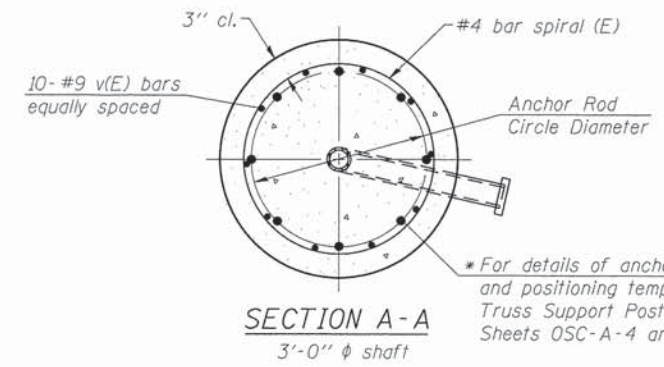

SECTION A-A  
3'-0"  $\phi$  shaft

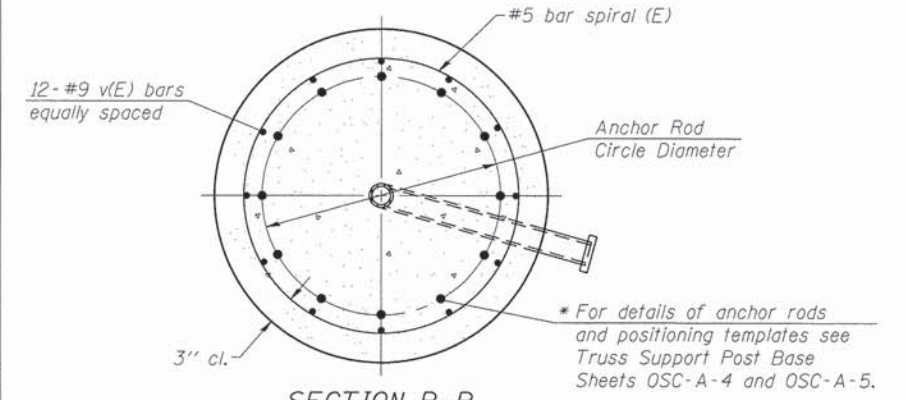

SECTION B-B  
3'-6"  $\phi$  shaft

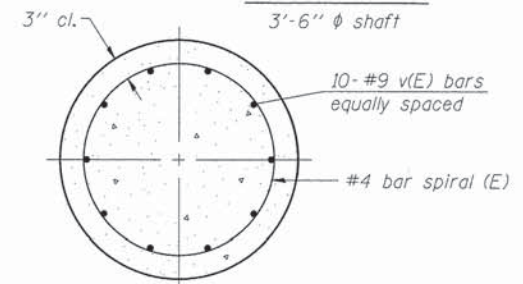

SECTION C-C  
3'-0"  $\phi$  shaft

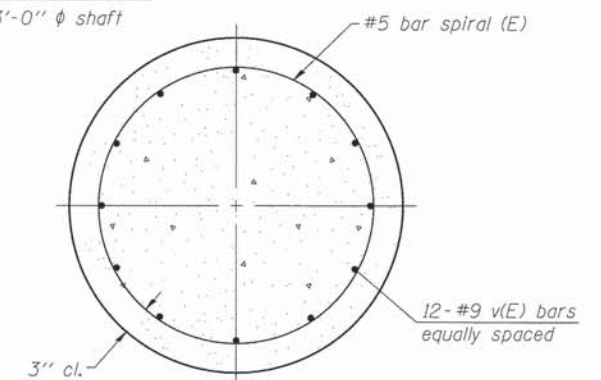

SECTION D-D  
3'-6"  $\phi$  shaft

NOTES:

The foundation dimensions shown in the Foundation Design Table are based on the presence of mostly cohesive soils with an average Unconfined Compressive Strength ( $Q_u$ ) of at least 1.25 tsf, which must be determined by previous soil investigations at the jobsite. When other conditions are indicated, the boring data will be included in the plans and the foundation dimensions shown in the Foundation Data Table will be the result of site specific designs.

If the conditions encountered are different than those indicated, the Contractor shall notify the Engineer to determine if the foundation dimensions need to be modified. If dimensions "B" or "F" are revised by more than 12" by the Contractor, "as-built" plans shall be prepared and submitted to the District Bureau of Operations for future reference.

No sonotubes or decomposable forms shall be used below the lower conduit entrance. Permanent metal forms or other shielding may not be left in place below that elevation without the Engineer's written permission.

Concrete shall be placed monolithically, without construction joints. Backfill shall be placed per Article 502 of Standard Specification and prior to erection of support column.

A normal surface finish followed by a Bridge Seat Sealer application will be required on concrete surfaces above the lowest elevation 6" below finished ground line. Cost included in "Drilled Shaft Concrete Foundation".

FOUNDATION DESIGN TABLE								
Truss Type	Post Base Sheet	Maximum Cantilever Length (ft)	Maximum Total Sign Area (sq ft)	Shaft Diameter (in)	"B" Depth (ft)	Anchor Rods		Anchor Rod Circle Diameter (in)
						No.	Diameter (in)	
I-C-A	OSC-A-4	25	170	3.0	16.0	8	2	22
II-C-A	OSC-A-5	30	170	3.5	17.0	12	2	30
II-C-A	OSC-A-5	30	340	3.5	21.5	12	2	30
III-C-A	OSC-A-5	35	170	3.5	19.0	12	2	30
III-C-A	OSC-A-5	35	250	3.5	22.5	12	2	30
III-C-A	OSC-A-5	35	400	3.5	26.5	12	2	30
III-C-A	OSC-A-5	40	400	3.5	32.0	12	2	30

FOUNDATION DATA TABLE										
Structure Number	Station	Truss Type	Shaft Diameter	Elevation Top	Elevation Bottom	$Q_u$	A	B	F	Class DS Concrete Cubic Yards
8C0821064R019.1	935+00	III-C-A	3.5	490.59	455.76	1.97	2'-10"	32'-0"	34'-10"	12.4
8C0821064R019.6	961+40	II-C-A	3.5	489.91	465.74	1.41	2'-8"	21'-6"	24'-2"	8.6
8C0821064R020.0	979+50	I-C-A	3.0	469.12	441.37	1.31	2'-9"	25'-0"	27'-9"	7.3

OSC-A-9

6-1-12

FILE NAME = 09-0016-sht-signcent1.dgn

USER NAME = IDOT  
 MODEL NAME = Default  
 PLOT SCALE = 1.0000 ' / in.  
 PLOT DATE = 4/27/2014

DESIGNED - JAH  
 DRAWN - TJH  
 CHECKED - LDC  
 DATE - April 29, 2014

REVISED -  
 REVISED -  
 REVISED -  
 REVISED -

STATE OF ILLINOIS  
 DEPARTMENT OF TRANSPORTATION

CANTILEVER SIGN STRUCTURES - DRILLED SHAFT  
 ALUMINUM TRUSS & STEEL POST  
 SCALE: SHEET NO. 10 OF 10 SHEETS STA. TO STA.

F.A.I. SECTION COUNTY TOTAL SHEETS SHEET NO.  
 64 09-00365-01-PV ST. CLAIR 535 289  
 TR RTE. 222 (RIEDER ROAD) CONTRACT NO. 97549  
 ILLINOIS

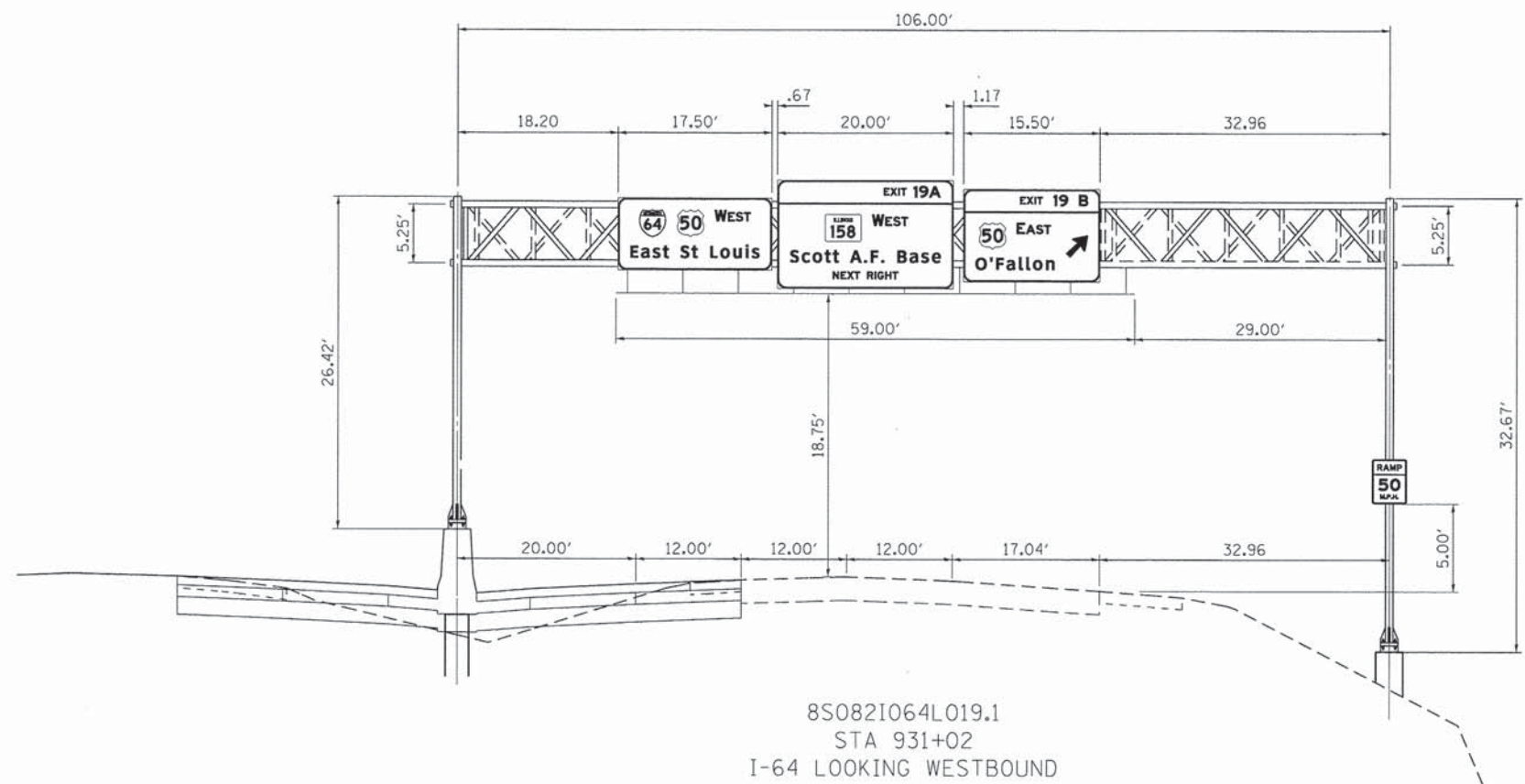
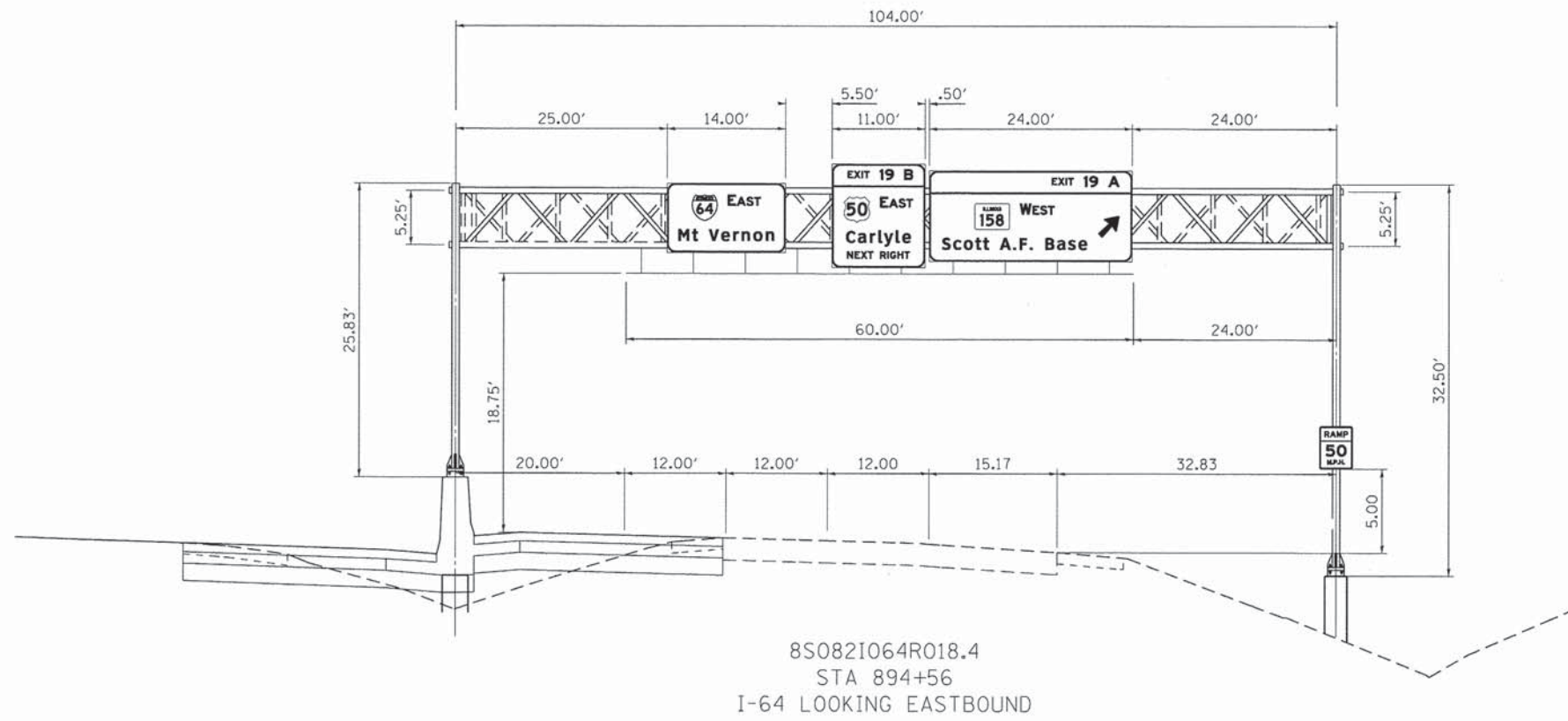

P:\09-2016-02\_Rieder\_Road\_Phase\_11\08\_CAD\CAD\_Sheets\09-2016-sht-signplace03.dgn

FILE NAME =	09-2016-sht-signplace03.dgn
MODEL NAME =	Default
PLOT SCALE =	10.0000' / in.
PLOT DATE =	4/26/2014

USER NAME =	100T
DESIGNED -	JAH
DRAWN -	TJH
CHECKED -	LDC
DATE -	April 29, 2014

REVISED -	
REVISED -	
REVISED -	
REVISED -	

**STATE OF ILLINOIS  
DEPARTMENT OF TRANSPORTATION**

<b>PROPOSED OVERHEAD SIGN STRUCTURES SIGN PLACEMENT</b>	
SCALE:	SHEET NO. 1 OF 3 SHEETS STA. TO STA.

F.A.I. RTE.	SECTION	COUNTY	TOTAL SHEETS	SHEET NO.
64	09-00365-01-PV	ST. CLAIR	535	290
TR RTE. 222 (RIEDER ROAD)			CONTRACT NO. 97549	
ILLINOIS				

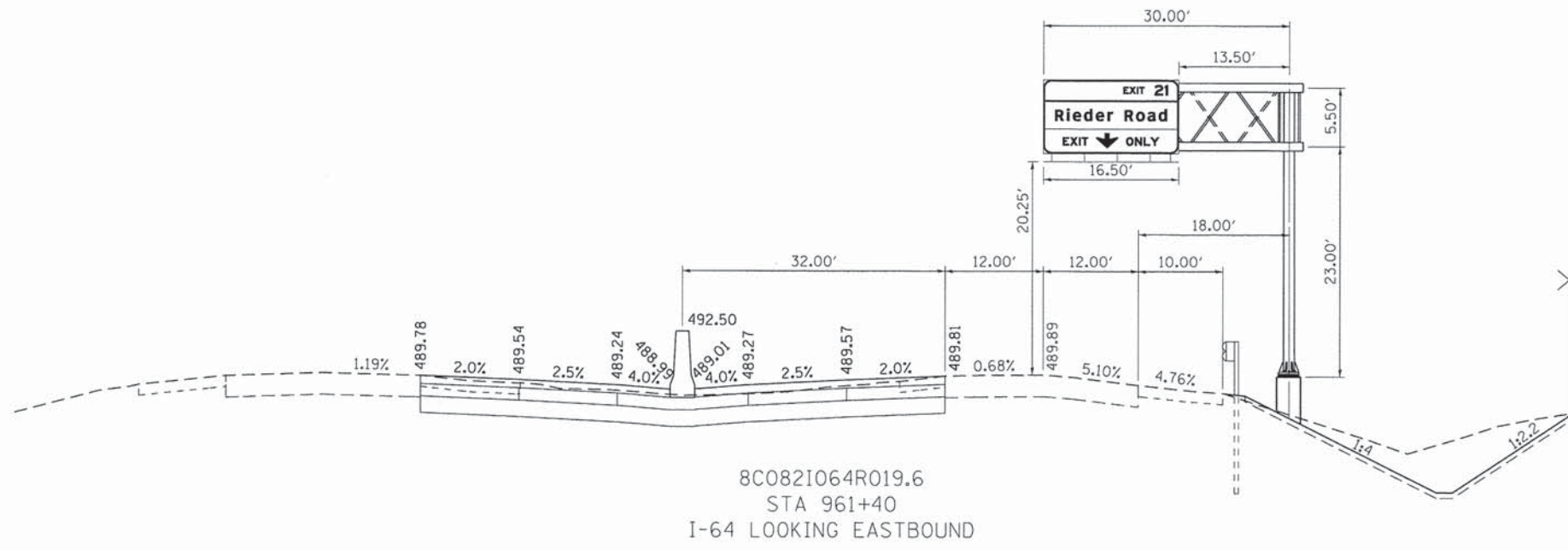
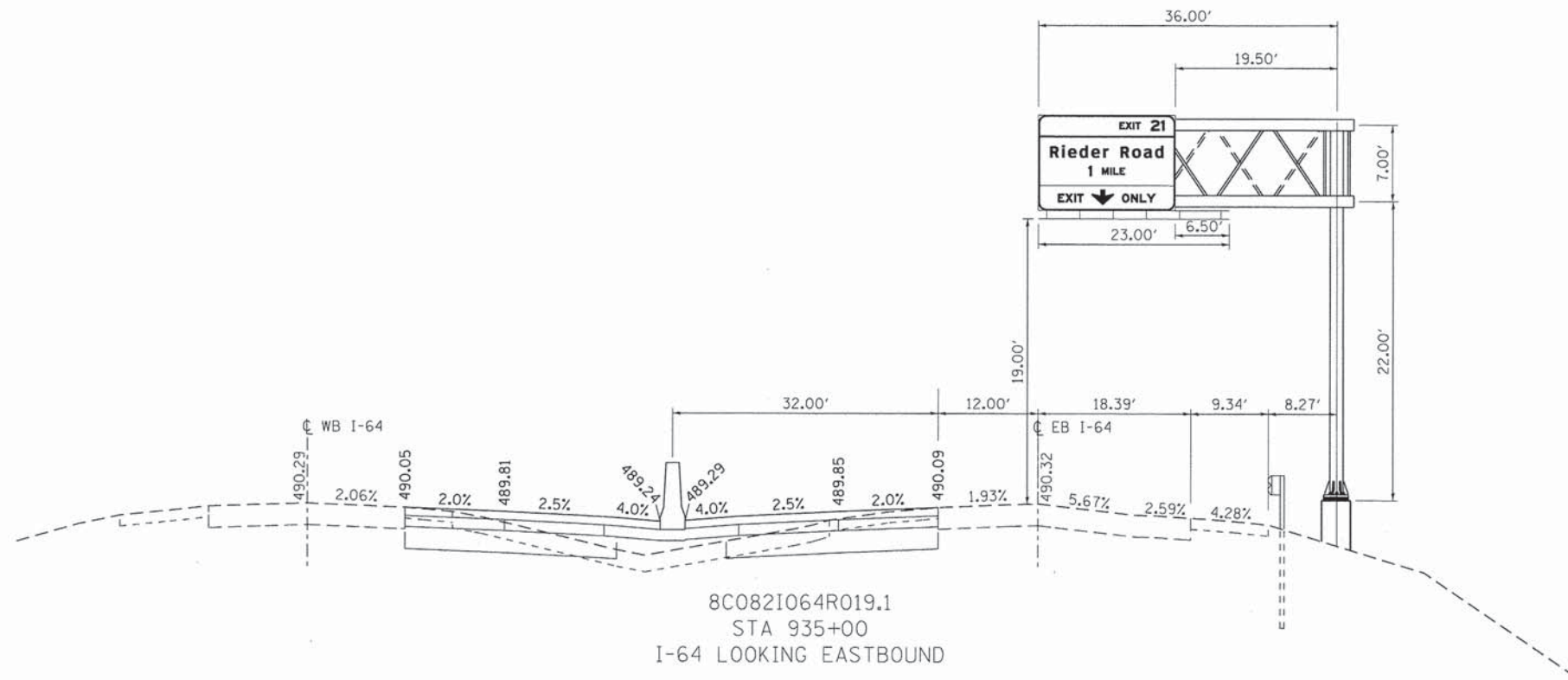

F:\09-0016\01622\_Rieder\_Road\_Phase\_II\110\_CAD\CAD00\_Sheets\09-0016-sh1-signplace01.dgn

FILE NAME = 09-0016-sh1-signplace01.dgn	USER NAME = IDOT	DESIGNED - JAH	REVISED - -
MODEL NAME = Default	DRAWN - TJH	CHECKED - LDC	REVISED - -
PLOT SCALE = 120,0000' / ft.	DATE - April 29, 2014	REVISIONS	

**STATE OF ILLINOIS  
DEPARTMENT OF TRANSPORTATION**

**PROPOSED OVERHEAD SIGN STRUCTURES  
SIGN PLACEMENT**

F.A.I. RTE.	SECTION	COUNTY	TOTAL SHEETS	SHEET NO.
64	09-00365-01-PV	ST. CLAIR	535	291
TR RTE. 222 (RIEDER ROAD)		CONTRACT NO. 97549		
ILLINOIS				

SCALE: SHEET NO. 2 OF 3 SHEETS STA. TO STA.

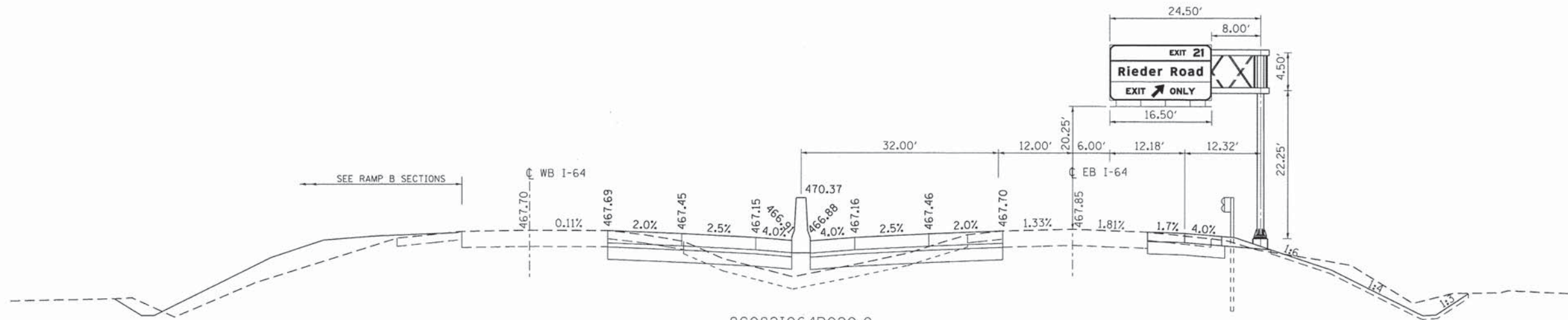

8C082I064R020.0  
 STA 979+50  
 I-64 LOOKING EASTBOUND

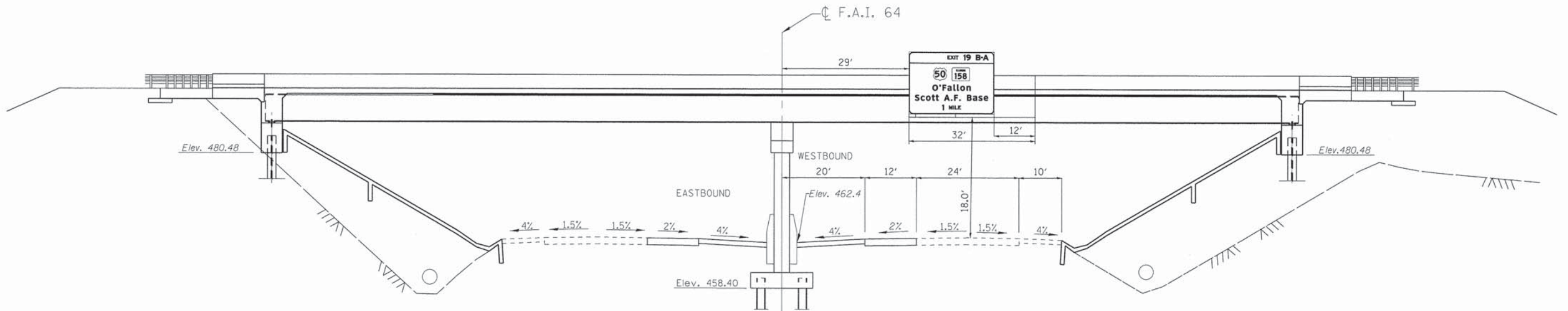

8B082I064L020.4  
 STA 998+40  
 I-64 LOOKING WESTBOUND

F:\09-0016\02\_Rieder\_Road\_Phase\_1\1\B\_CADD\CADD\_Sheets\09-0016-sht-signplace02.dgn

FILE NAME = 09-0016-sht-signplace02.dgn	USER NAME = IDOT	DESIGNED - JAH	REVISED -
	MODEL NAME = Default	DRAWN - TJH	REVISED -
	PLOT SCALE = 1/28,000 @ 1/4" = 1' ft.	CHECKED - LDC	REVISED -
	PLOT DATE = 4/26/2014	DATE - April 29, 2014	REVISED -

**STATE OF ILLINOIS**  
**DEPARTMENT OF TRANSPORTATION**

**PROPOSED OVERHEAD SIGN STRUCTURES**  
**SIGN PLACEMENT**

SCALE: SHEET NO. 3 OF 3 SHEETS STA. TO STA.

F.A.I. RTE.	SECTION	COUNTY	TOTAL SHEETS	SHEET NO.
64	09-00365-01-PV	ST. CLAIR	535	292
TR RTE. 222 (RIEDER ROAD)			CONTRACT NO. 97549	
ILLINOIS				



DETECTOR LOOP AND DETECTOR ASSIGNMENT SCHEDULE RIEDER ROAD AND WHERRY ROAD								
DETECTOR LOOP	PHASE (Ø)	LOOP SIZE (FT)	REQUIRED # OF TURNS	DETECTOR LEAD-IN QTY.	CALCULATED INDUCTANCE MICROHENRIES	CALCULATED RESISTANCE OHMS	DETECTOR LOOP QTY.	CHANNELS REQUIRED
C.D. #1	4	6X50 (Q)	3-6-3	313	854.86	3.16	162	1
C.D. #2	7	6X50 (Q)	3-6-3	378	869.16	3.48	162	1
C.C.O. #3	4	6X6	7	733	527.29	4.09	24	1
C.D. #4	6	6X50 (Q)	3-6-3	204	830.88	2.61	162	1
C.D. #5	6	6X50 (Q)	3-6-3	204	830.88	2.61	162	1
C.D. #6	6	6X50 (Q)	3-6-3	204	830.88	2.61	162	1
C.D. #7	1	6X50 (Q)	3-6-3	136	815.92	2.27	162	1
C.C.O. #8	6	6X6	7	594	496.71	3.39	24	1
C.C.O. #9	6	6X6	7	594	496.71	3.39	24	1
C.D. #10	RESERVED							
C.D. #11	RESERVED							
C.D. #12	2	6X50 (Q)	3-6-3	156	820.32	2.37	162	1
C.D. #13	2	6X50 (Q)	3-6-3	156	820.32	2.37	162	1
C.D. #14	5	6X50 (Q)	3-6-3	232	837.04	2.75	162	1
C.D. #15	5	6X50 (Q)	3-6-3	232	837.04	2.75	162	1
<b>TOTAL:</b>							<b>1692</b>	<b>13</b>

THE ABOVE VALUES ARE CALCULATED OF COMBINED LOOP AND LEAD-IN INDUCTANCE AND RESISTANCE. ACTUAL MEASURED VALUES SHOULD BE WITHIN +/- 20% OF THESE VALUES.

DETECTOR LOOP AND DETECTOR ASSIGNMENT SCHEDULE RIEDER ROAD AND RAMP C AND D								
DETECTOR LOOP	PHASE (Ø)	LOOP SIZE (FT)	REQUIRED # OF TURNS	DETECTOR LEAD-IN QTY.	CALCULATED INDUCTANCE MICROHENRIES	CALCULATED RESISTANCE OHMS	DETECTOR LOOP QTY.	CHANNELS REQUIRED
C.D. #1	7	6X50 (Q)	3-6-3	219	834.18	2.69	162	1
C.D. #2	7	6X50 (Q)	3-6-3	219	834.18	2.69	162	1
C.C.O. #3	7	6X6	6	479	360.26	2.76	24	1
C.C.O. #4	7	6X6	6	479	360.26	2.76	24	1
C.D. #5	6	6X50 (Q)	3-6-3	152	819.44	2.35	162	1
C.D. #6	6	6X50 (Q)	3-6-3	152	819.44	2.35	162	1
C.D. #7	1	6X50 (Q)	3-6-3	268	844.96	2.93	162	1
C.D. #8	1	6X50 (Q)	3-6-3	268	844.96	2.93	162	1
C.C.O. #9	6	6X6	6	411	345.30	2.42	24	1
C.C.O. #10	6	6X6	6	411	345.30	2.42	24	1
C.D. #11	2	6X50 (Q)	3-6-3	173	824.06	2.46	162	1
C.D. #12	2	6X50 (Q)	3-6-3	102	808.44	2.10	162	1
C.D. #13	2	6X50 (Q)	3-6-3	102	808.44	2.10	162	1
C.C.O. #14	2	6X6	6	507	366.42	2.90	24	1
C.C.O. #15	2	6X6	6	507	366.42	2.90	24	1
<b>TOTAL:</b>							<b>1602</b>	<b>15</b>

THE ABOVE VALUES ARE CALCULATED OF COMBINED LOOP AND LEAD-IN INDUCTANCE AND RESISTANCE. ACTUAL MEASURED VALUES SHOULD BE WITHIN +/- 20% OF THESE VALUES.

SCHEDULE OF SIGNAL HEADS RIEDER ROAD AND WHERRY ROAD			
QTY.	UNIT	ITEM	SIGNAL #
9	EACH	SH, P, LED, 1F, 3-SEC, BM	5,6,9,10,14,15,18,19,20
11	EACH	SH, P, LED, 1F, 3-SEC, MAM	1,2,3,4,7,8,11,12,13,16,17
11	EACH	TRAFFIC SIGNAL BACKPLATE, FORMED PLASTIC	1,2,3,4,7,8,11,12,13,16,17

SCHEDULE OF SIGNAL HEADS RIEDER ROAD AND RAMP C AND D			
QTY.	UNIT	ITEM	SIGNAL #
5	EACH	SH, P, LED, 1F, 3-SEC, BM	3,6,7,8,13
8	EACH	SH, P, LED, 1F, 3-SEC, MAM	1,2,4,5,9,10,11,12
8	EACH	TRAFFIC SIGNAL BACKPLATE, FORMED PLASTIC	1,2,4,5,9,10,11,12

DETECTOR LOOP AND DETECTOR ASSIGNMENT SCHEDULE PROPOSED RIEDER ROAD AND RAMP A AND B								
DETECTOR LOOP	PHASE (Ø)	LOOP SIZE (FT)	REQUIRED # OF TURNS	DETECTOR LEAD-IN QTY.	CALCULATED INDUCTANCE MICROHENRIES	CALCULATED RESISTANCE OHMS	DETECTOR LOOP QTY.	CHANNELS REQUIRED
C.D. #1	6	6X50 (Q)	3-6-3	210	832.20	2.64	162	1
C.D. #2	6	6X50 (Q)	3-6-3	210	832.20	2.64	162	1
C.D. #3	6	6X50 (Q)	3-6-3	210	832.20	2.64	162	1
C.C.O. #4	6	6X6	7	583	494.29	3.34	24	1
C.C.O. #5	6	6X6	7	583	494.29	3.34	24	1
C.D. #6	8	6X50 (Q)	3-6-3	25	791.50	1.72	162	1
C.D. #7	8	6X50 (Q)	3-6-3	84	804.48	2.01	162	1
C.D. #8	3	6X50 (Q)	3-6-3	84	804.48	2.01	162	1
C.C.O. #9	8	6X6	5	254	224.63	1.57	24	1
C.C.O. #10	8	6X6	5	254	224.63	1.57	24	1
C.C.O. #11	3	6X6	5	254	224.63	1.57	24	1
C.D. #12	2	6X50 (Q)	3-6-3	162	821.64	2.40	162	1
C.D. #13	2	6X50 (Q)	3-6-3	162	821.64	2.40	162	1
C.D. #14	5	6X50 (Q)	3-6-3	226	835.72	2.72	162	1
C.D. #15	5	6X50 (Q)	3-6-3	226	835.72	2.72	162	1
C.C.O. #16	2	6X6	6	482	360.92	2.77	24	1
C.C.O. #17	2	6X6	6	482	360.92	2.77	24	1
<b>TOTAL:</b>							<b>1788</b>	<b>17</b>

THE ABOVE VALUES ARE CALCULATED OF COMBINED LOOP AND LEAD-IN INDUCTANCE AND RESISTANCE. ACTUAL MEASURED VALUES SHOULD BE WITHIN +/- 20% OF THESE VALUES.

DETECTOR LOOP AND DETECTOR ASSIGNMENT SCHEDULE RIEDER ROAD AND SHILOH VALLEY TOWNSHIP ROAD								
DETECTOR LOOP	PHASE (Ø)	LOOP SIZE (FT)	REQUIRED # OF TURNS	DETECTOR LEAD-IN QTY.	CALCULATED INDUCTANCE MICROHENRIES	CALCULATED RESISTANCE OHMS	DETECTOR LOOP QTY.	CHANNELS REQUIRED
C.D. #1	4	6X50 (Q)	3-6-3	224	835.28	2.71	162	1
C.D. #2	7	6X50 (Q)	3-6-3	224	835.28	2.71	162	1
C.C.O. #3	4	6X6	6	515	368.18	2.94	24	1
C.D. #4	6	6X50 (Q)	3-6-3	336	859.92	3.27	162	1
C.D. #5	6	6X50 (Q)	3-6-3	336	859.92	3.27	162	1
C.D. #6	1	6X50 (Q)	3-6-3	262	843.64	2.90	162	1
C.C.O. #7	6	6X6	7	643	507.49	3.64	24	1
C.C.O. #8	6	6X6	7	643	507.49	3.64	24	1
C.D. #9	8	6X50 (Q)	3-6-3	235	837.70	2.77	162	1
C.D. #10	3	6X50 (Q)	3-6-3	235	837.70	2.77	162	1
C.D. #11	3	6X50 (Q)	3-6-3	235	837.70	2.77	162	1
C.C.O. #12	RESERVED							
C.D. #13	2	6X50 (Q)	3-6-3	88	805.36	2.03	162	1
C.D. #14	2	6X50 (Q)	3-6-3	88	805.36	2.03	162	1
C.D. #15	5	6X50 (Q)	3-6-3	88	805.36	2.03	162	1
C.D. #16	5	6X50 (Q)	3-6-3	88	805.36	2.03	162	1
C.C.O. #17	2	6X6	5	343	244.21	2.02	24	1
C.C.O. #18	2	6X6	5	343	244.21	2.02	24	1
<b>TOTAL:</b>							<b>2064</b>	<b>17</b>

THE ABOVE VALUES ARE CALCULATED OF COMBINED LOOP AND LEAD-IN INDUCTANCE AND RESISTANCE. ACTUAL MEASURED VALUES SHOULD BE WITHIN +/- 20% OF THESE VALUES.

SCHEDULE OF SIGNAL HEADS RIEDER ROAD AND RAMP A AND B			
QTY.	UNIT	ITEM	SIGNAL #
7	EACH	SH, P, LED, 1F, 3-SEC, BM	5,6,7,10,13,14,15
8	EACH	SH, P, LED, 1F, 3-SEC, MAM	1,2,3,4,8,9,11,12
8	EACH	TRAFFIC SIGNAL BACKPLATE, FORMED PLASTIC	1,2,3,4,8,9,11,12

SCHEDULE OF SIGNAL HEADS RIEDER ROAD AND SHILOH VALLEY TOWNSHIP ROAD			
QTY.	UNIT	ITEM	SIGNAL #
8	EACH	SH, P, LED, 1F, 3-SEC, BM	5,6,9,10,14,15,19,20
12	EACH	SH, P, LED, 1F, 3-SEC, MAM	1,2,3,4,7,8,11,12,13,16,17,18
12	EACH	TRAFFIC SIGNAL BACKPLATE, FORMED PLASTIC	1,2,3,4,7,8,11,12,13,16,17,18

F:\09-0016\p2\_Rieder\_Road\_Phase\_1\10\_040\0400\_Sheet\09-0016-sh-t-TS.schedules.dgn

FILE NAME = 09-0016-sh-t-TS.schedules.dgn

USER NAME =	IDOT	DESIGNED -	SMS	REVISED -	
MODEL NAME =	Default	DRAWN -	SMS	REVISED -	
PLOT SCALE =	240.0000' / Ft.	CHECKED -	LDC	REVISED -	
PLOT DATE =	4/26/2014	DATE -	Apr 29, 2014	REVISED -	

STATE OF ILLINOIS  
DEPARTMENT OF TRANSPORTATION

TRAFFIC SIGNAL SCHEDULES

SCALE: SHEET NO. 2 OF 18 SHEETS STA. TO STA.

F.A.I. RTE.	SECTION	COUNTY	TOTAL SHEETS	SHEET NO.
64	09-00365-01-PV	ST. CLAIR	535	294
TR RTE. 222 (RIEDER ROAD)		CONTRACT NO. 97549		
ILLINOIS				

SCHEDULE OF POST & MAST ARM ASSEMBLIES RIEDER ROAD AND WHERRY ROAD					
REF.	LOCATION	TYPE	LENGTH	FOUNDATION DEPTH	FOUNDATION DIAMETER
MA-1	NORTHEAST QUAD	S MAA & P	75 FT	25 FT	42 IN
MA-2	SOUTHEAST QUAD	S MAA & P	54 FT	15 FT	36 IN
MA-3	SOUTHWEST QUAD	S MAA & P	65 FT	25 FT	42 IN
MA-4	NORTH ISLAND	S MAA & P	52 FT	15 FT	36 IN
TSP-1	NORTHWEST QUAD	TS POST	13 FT	3 FT	24 IN

SCHEDULE OF POST & MAST ARM ASSEMBLIES RIEDER ROAD AND RAMP C AND D					
REF.	LOCATION	TYPE	LENGTH	FOUNDATION DEPTH	FOUNDATION DIAMETER
MA-1	NORTHEAST QUAD	S MAA & P	32 FT	11 FT	36 IN
MA-2	SOUTHEAST ISLAND	S MAA & P	34 FT	11 FT	36 IN
MA-3	SOUTHWEST ISLAND	S MAA & P	58 FT	21 FT	42 IN
TSP-1	SOUTHEAST QUAD	TS POST	13 FT	3 FT	24 IN
TSP-2	NORTHWEST QUAD	TS POST	13 FT	3 FT	24 IN

SCHEDULE OF POST & MAST ARM ASSEMBLIES RIEDER ROAD AND RAMP A AND B					
REF.	LOCATION	TYPE	LENGTH	FOUNDATION DEPTH	FOUNDATION DIAMETER
MA-1	NORTHEAST ISLAND	S MAA & P	58 FT	21 FT	42 IN
MA-2	SOUTHWEST QUAD	S MAA & P	30 FT	11 FT	36 IN
MA-3	NORTHWEST ISLAND	S MAA & P	34 FT	11 FT	36 IN
TSP-1	NORTHEAST QUAD	TS POST	13 FT	3 FT	24 IN
TSP-2	SOUTHEAST QUAD	TS POST	13 FT	3 FT	24 IN
TSP-3	NORTHWEST QUAD	TS POST	13 FT	3 FT	24 IN

SCHEDULE OF POST & MAST ARM ASSEMBLIES RIEDER ROAD AND SHILOH VALLEY TOWNSHIP ROAD					
REF.	LOCATION	TYPE	LENGTH	FOUNDATION DEPTH	FOUNDATION DIAMETER
MA-1	NORTHEAST QUAD	S MAA & P	75 FT	25 FT	42 IN
MA-2	SOUTHEAST QUAD	S MAA & P	65 FT	25 FT	42 IN
MA-3	SOUTHWEST QUAD	S MAA & P	65 FT	25 FT	42 IN
MA-4	NORTHWEST QUAD	S MAA & P	65 FT	25 FT	42 IN

SCHEDULE OF HANDHOLE QUANTITIES RIEDER ROAD AND WHERRY ROAD		
REF.	LOCATION	TYPE
DHH-1	NORTHEAST QUAD	DOUBLE
HH-2	SOUTHEAST QUAD	STANDARD
HH-3	NORTHBOUND LEFT TURN LOOPS	STANDARD
HH-4	SOUTHWEST QUAD	STANDARD
HH-5	EASTBOUND LEFT TURN LOOP	STANDARD
HH-6	EASTBOUND ADV LOOP	STANDARD
HH-7	NORTHWEST QUAD	STANDARD
HH-8	SOUTHBOUND ADV LOOPS	STANDARD
HH-9	NORTH ISLAND	STANDARD
HH-10	NORTH MEDIAN	STANDARD
HH-11	INTERCONNECT	STANDARD

SCHEDULE OF HANDHOLE QUANTITIES RIEDER ROAD AND RAMP C AND D		
REF.	LOCATION	TYPE
DHH-1	NORTHEAST QUAD	DOUBLE
HH-2	SOUTHEAST QUAD	STANDARD
HH-3	NORTHBOUND ADV LOOPS	STANDARD
HH-4	SOUTHEAST ISLAND	STANDARD
HH-5	SOUTHWEST ISLAND	STANDARD
HH-6	WESTBOUND ADV LOOPS	STANDARD
HH-7	NORTHWEST QUAD	STANDARD
HH-8	SOUTHBOUND LEFT TURN LOOPS	STANDARD
HH-9	SOUTHBOUND ADV LOOPS	STANDARD
HH-10	INTERCONNECT	STANDARD

SCHEDULE OF HANDHOLE QUANTITIES RIEDER ROAD AND RAMP A AND B		
REF.	LOCATION	TYPE
DHH-1	NORTHEAST QUAD	DOUBLE
HH-2	WESTBOUND ADV LOOPS	STANDARD
HH-3	NORTHEAST ISLAND	STANDARD
HH-4	SOUTHEAST QUAD	STANDARD
HH-5	NORTHBOUND LEFT TURN LOOPS	STANDARD
HH-6	NORTHBOUND ADV LOOPS	STANDARD
HH-7	SOUTHWEST QUAD	STANDARD
HH-8	NORTHWEST ISLAND	STANDARD
HH-9	NORTHWEST QUAD	STANDARD
HH-10	SOUTHBOUND ADV LOOPS	STANDARD
HH-11	INTERCONNECT	STANDARD

SCHEDULE OF HANDHOLE QUANTITIES RIEDER ROAD AND SHILOH VALLEY TOWNSHIP ROAD		
REF.	LOCATION	TYPE
HH-1	NORTHEAST QUAD	STANDARD
HH-2	WESTBOUND LEFT TURN LOOPS	STANDARD
HH-3	WESTBOUND ADV LOOPS	STANDARD
DHH-4	SOUTHEAST QUAD	DOUBLE
HH-5	NORTHBOUND PRESENCE LOOPS	STANDARD
HH-6	NORTHBOUND ADV LOOPS	STANDARD
HH-7	SOUTHWEST QUAD	STANDARD
HH-8	EASTBOUND ADV LOOPS	STANDARD
HH-9	NORTHWEST QUAD	STANDARD
HH-10	SOUTHBOUND ADV LOOPS	STANDARD
HH-11	NORTH MEDIAN	STANDARD

F:\09-0016\02\_Rieder\_Road\_Phase\_1\118\_CAD\CAD00\_Schedule\09-0016-sht-TS.schedules2.dgn

FILE NAME = 09-0016-sht-TS.schedules2.dgn	USER NAME = IDOT	DESIGNED - SMS	REVISED -
MODEL NAME = Default	DRAWN - SMS	CHECKED - LDC	REVISED -
PLOT SCALE = 240.0000 ' / ft.	DATE - April 29, 2014	REVISED -	
PLOT DATE = 4/26/2014			

**STATE OF ILLINOIS  
DEPARTMENT OF TRANSPORTATION**

**TRAFFIC SIGNAL SCHEDULES**

SCALE: SHEET NO. 3 OF 18 SHEETS STA. TO STA.

F.A.I. RTE.	SECTION	COUNTY	TOTAL SHEETS	SHEET NO.
64	09-00365-01-PV	ST. CLAIR	535	295
TR RTE. 222 (RIEDER ROAD)			CONTRACT NO. 97549	
ILLINOIS				

**TRAFFIC SIGNAL LEGEND**

- ➔ PROPOSED SIGNAL HEAD WITH BACKPLATE
- ➔ PROPOSED SIGNAL HEAD WITHOUT BACKPLATE
- PROPOSED HANDHOLE
- PROPOSED DOUBLE HANDHOLE
- PROPOSED JUNCTION BOX
- ▬ PROPOSED CONDUIT
- ▬ PROPOSED MAST ARM (LENGTH SPECIFIED)
- PROPOSED TRAFFIC SIGNAL POST
- PROPOSED SERVICE POLE
- PROPOSED CONTROLLER WITH CONCRETE FOUNDATION, TYPE D
- ▭ PROPOSED DETECTOR LOOP (6' X 50')
- ▭ PROPOSED DETECTOR LOOP (6' X 6')
- PROPOSED SIGN

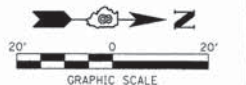
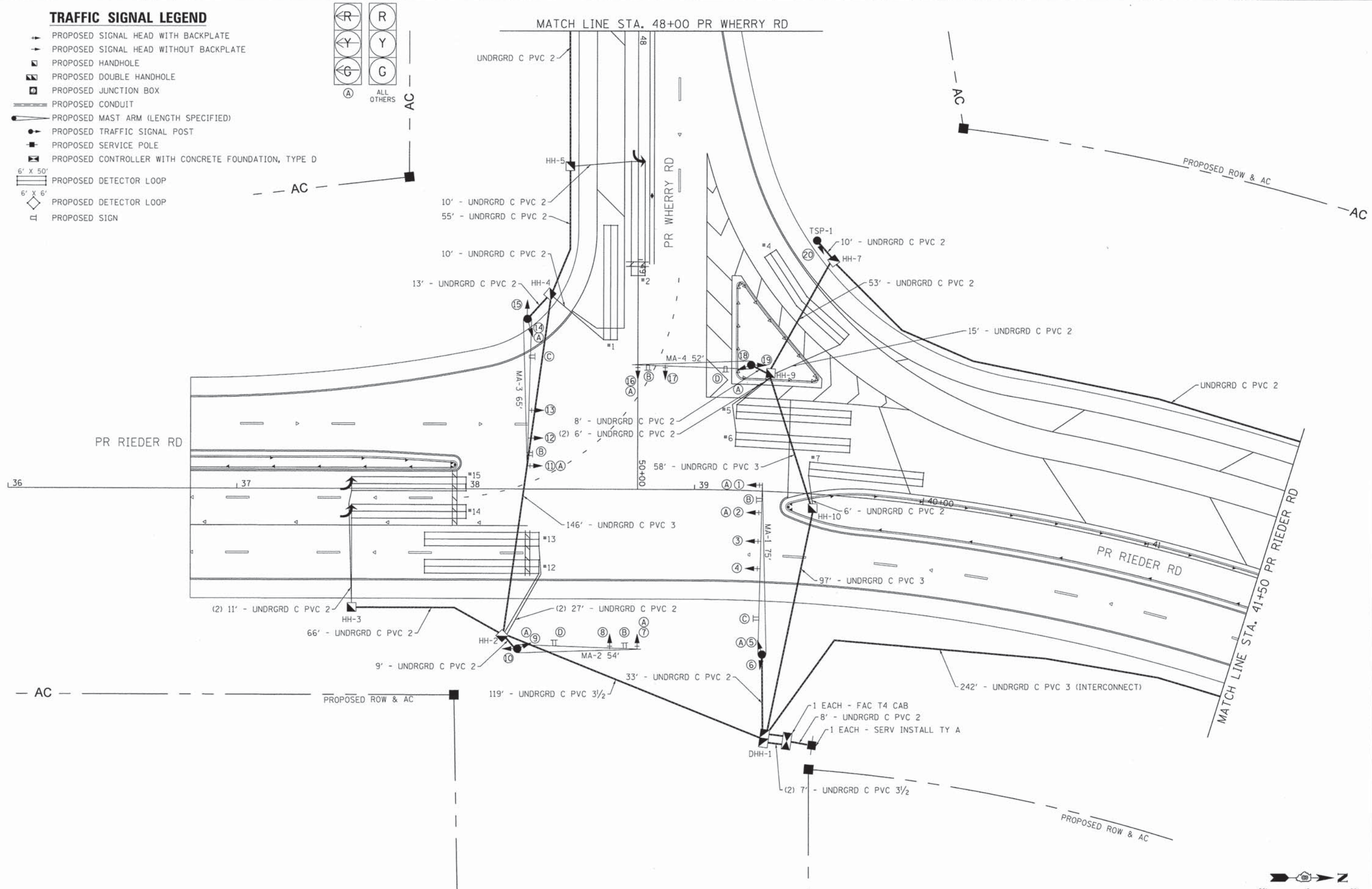

P:\09-2016-02\_Rieder\_Road\_Phase\_1\1119\_CADD\CADD\_Sheets\09-2016-ah-1-TS01.dgn

FILE NAME = 09-2016-ah-1-TS01.dgn	USER NAME = IDOT	DESIGNED - SMS	REVISED -
MODEL NAME = Default	DRAWN - SMS	REVISED -	
PLOT SCALE = 240.0000' / ft.	CHECKED - LDC	REVISED -	
PLOT DATE = 4/26/2014	DATE - April 29, 2014	REVISED -	

**STATE OF ILLINOIS  
DEPARTMENT OF TRANSPORTATION**

**TRAFFIC SIGNAL INSTALLATION PLAN  
PROPOSED RIEDER ROAD & PROPOSED WHERRY ROAD**

SCALE: 1"=20'    SHEET NO. 4 OF 18 SHEETS    STA. TO STA.

F.A.I. RTE.	SECTION	COUNTY	TOTAL SHEETS	SHEET NO.
64	09-00365-01-PV	ST. CLAIR	535	296
TR RTE. 222 (RIEDER ROAD)		CONTRACT NO. 97549		
ILLINOIS				



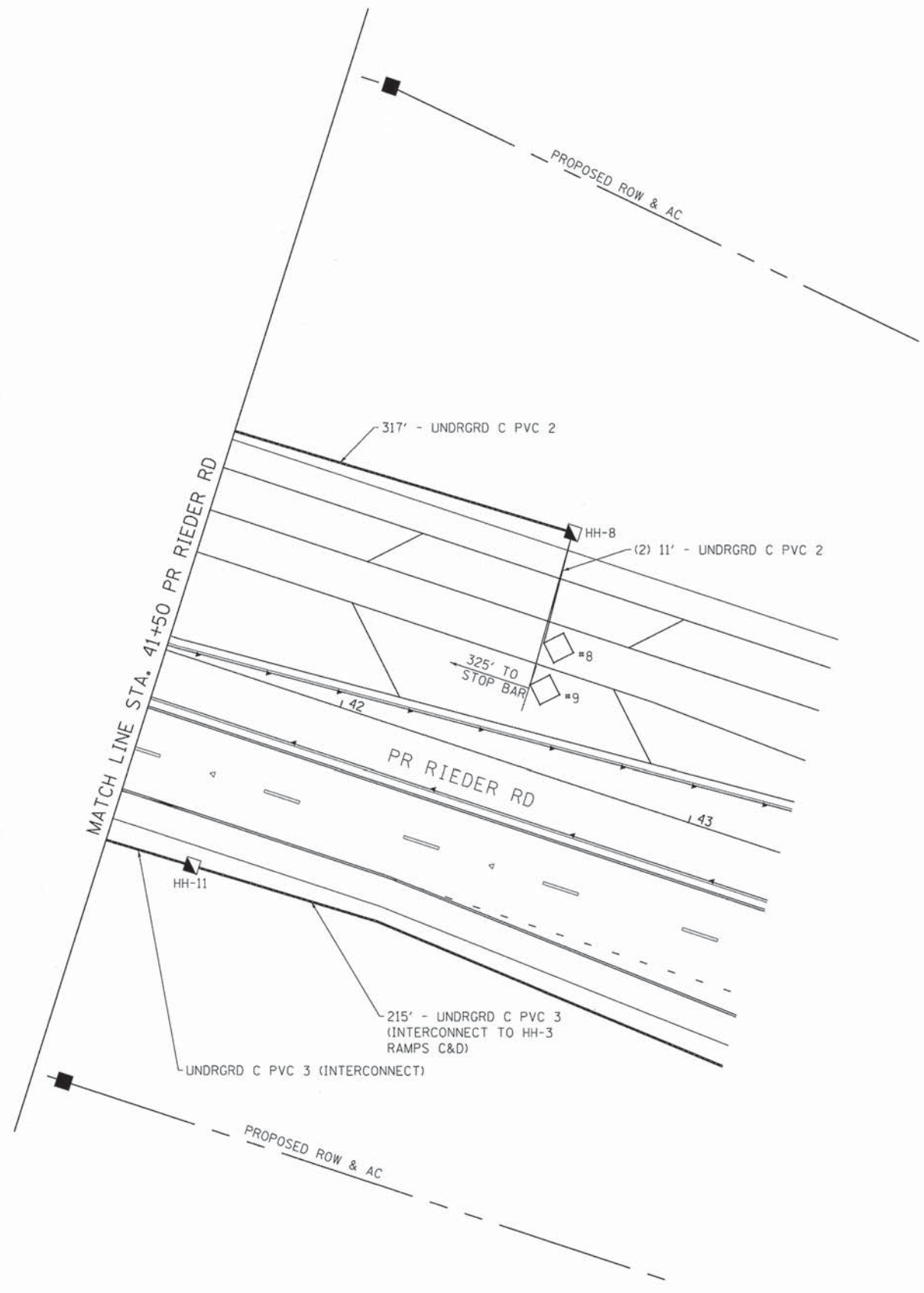
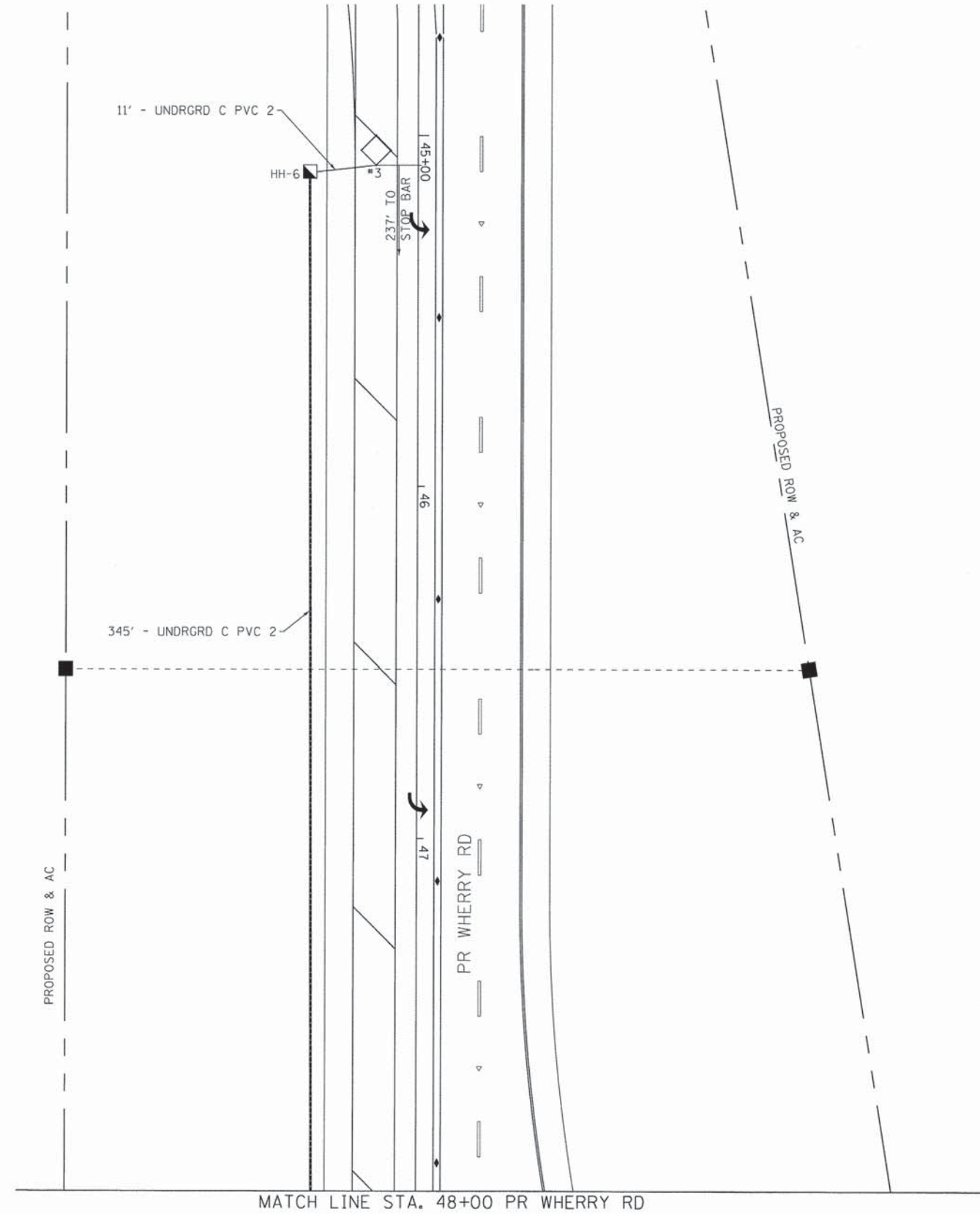

F:\Users\021622\_Rieder\_Road\_Phase\_1\1\18\_CADD\_Sheets\09-0016-sh1-TS01B.dgn

FILE NAME = 09-0016-sh1-TS01B.dgn	USER NAME = 100T	DESIGNED - SMS	REVISED -
	MODEL NAME = Default	DRAWN - SMS	REVISED -
	PLOT SCALE = 240.0000' / Ft.	CHECKED - LDC	REVISED -
	PLOT DATE = 4/26/2014	DATE - April 29, 2014	REVISED -

**STATE OF ILLINOIS  
DEPARTMENT OF TRANSPORTATION**

**TRAFFIC SIGNAL INSTALLATION PLAN  
PROPOSED RIEDER ROAD & PROPOSED WHERRY ROAD**

F.A.I. RTE.	SECTION	COUNTY	TOTAL SHEETS	SHEET NO.
64	09-00365-01-PV	ST. CLAIR	535	297
TR RTE. 222 (RIEDER ROAD)		CONTRACT NO. 97549		
ILLINOIS				

SCALE: 1"=20'      SHEET NO. 5 OF 18 SHEETS      STA.      TO STA.



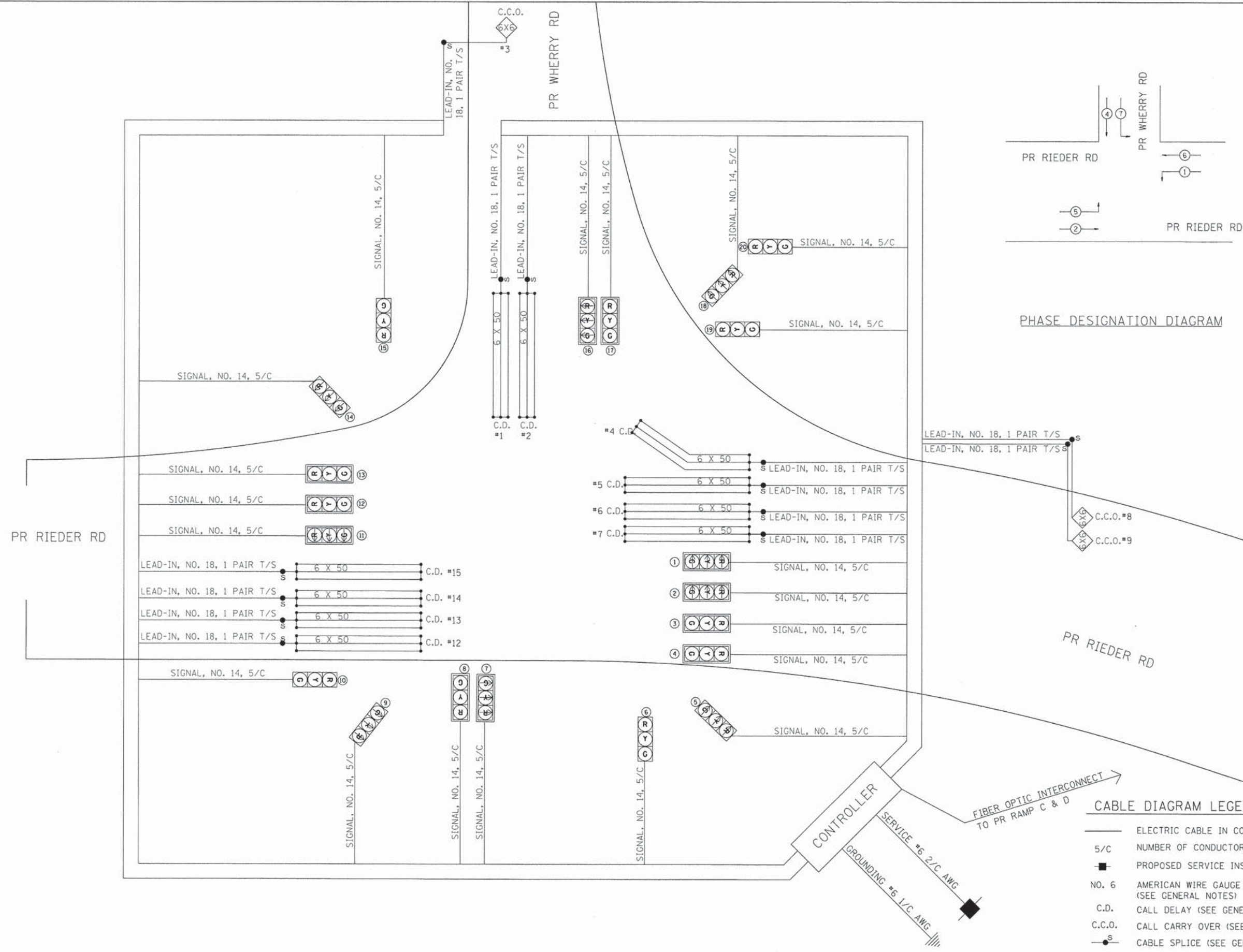

P:\BTR\2014\02 Rieder Road Phase II\B.CADD\CADD Sheets\09-0016-sht-1501A.dgn

FILE NAME = 09-0016-sht-1501A.dgn	USER NAME = IDOT	DESIGNED - SMS	REVISED -
MODEL NAME = Default	DRAWN - SMS	CHECKED - LDC	REVISED -
PLOT SCALE = 240.0000 ' / ft.	DATE - April 29, 2014		REVISED -

**STATE OF ILLINOIS**  
**DEPARTMENT OF TRANSPORTATION**

**TRAFFIC SIGNAL CABLE DIAGRAM**  
**PROPOSED RIEDER ROAD & PROPOSED WHERRY ROAD**

SCALE: SHEET NO. 6 OF 18 SHEETS STA. TO STA.

F.A.I. RTE.	SECTION	COUNTY	TOTAL SHEETS	SHEET NO.
64	09-00365-01-PV	ST. CLAIR	535	298
TR RTE. 222 (RIEDER ROAD)		CONTRACT NO. 97549		
[ILLINOIS]				



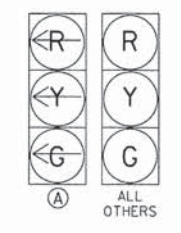
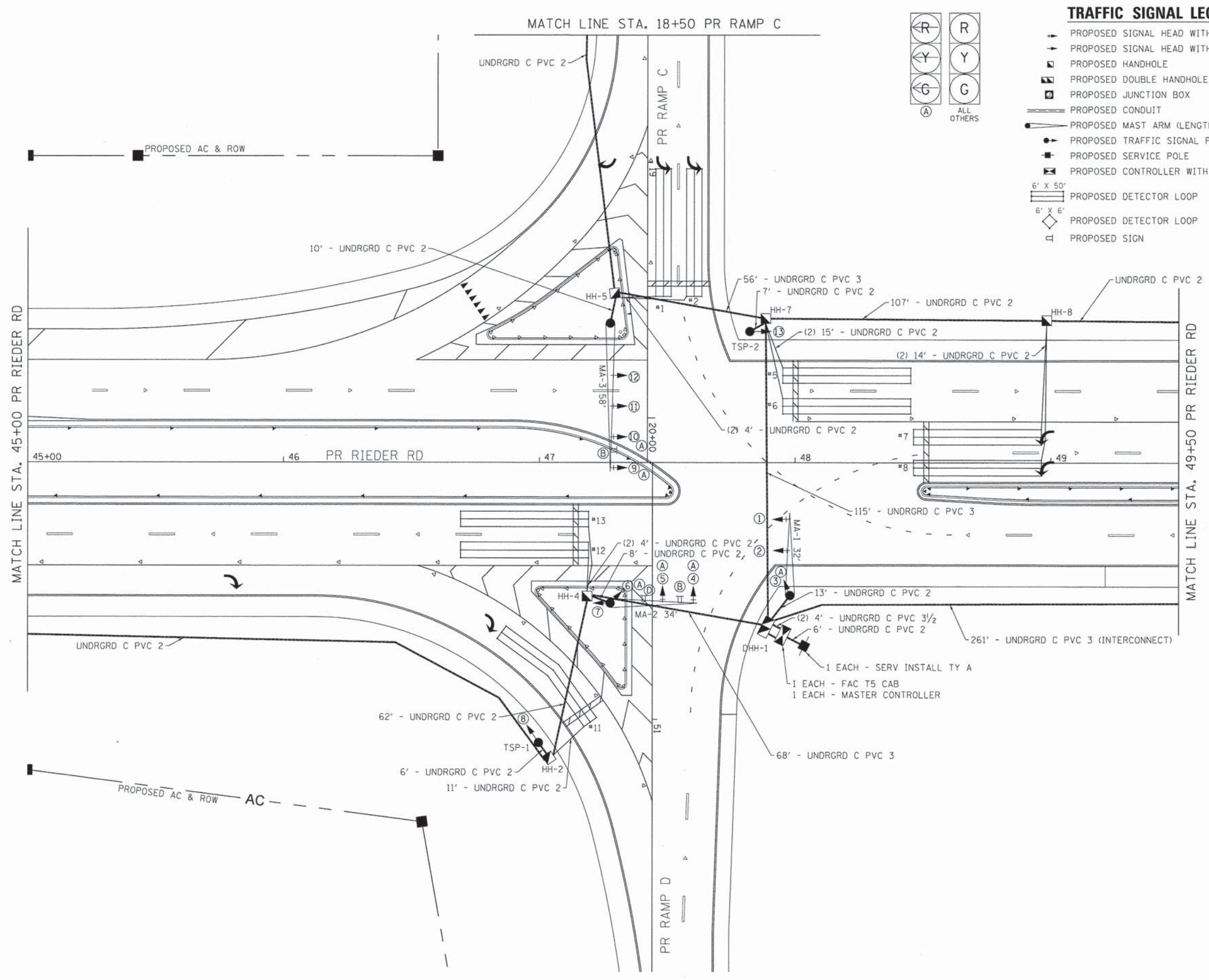

- TRAFFIC SIGNAL LEGEND**
- PROPOSED SIGNAL HEAD WITH BACKPLATE
  - PROPOSED SIGNAL HEAD WITHOUT BACKPLATE
  - ⊠ PROPOSED HANDHOLE
  - ⊠ PROPOSED DOUBLE HANDHOLE
  - ⊠ PROPOSED JUNCTION BOX
  - PROPOSED CONDUIT
  - PROPOSED MAST ARM (LENGTH SPECIFIED)
  - PROPOSED TRAFFIC SIGNAL POST
  - PROPOSED SERVICE POLE
  - ⊠ PROPOSED CONTROLLER WITH CONCRETE FOUNDATION, TYPE D
  - ▭ PROPOSED DETECTOR LOOP (6' X 50')
  - ◊ PROPOSED DETECTOR LOOP (6' X 6')
  - ⊠ PROPOSED SIGN

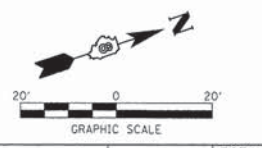

P:\P\09-00365-01-PR-Rieder-Road-Phase-1\1118\_CAD\CADD\_Sheets\09-00365-01-PR-0016-sh1-TS02.dgn

FILE NAME = 09-0016-sh1-TS02.dgn	USER NAME = IDOT	DESIGNED - SMS	REVISED -
MODEL NAME = Default	DRAWN - SMS	DRAWN - SMS	REVISED -
PLOT SCALE = 240.0000' / ft.	CHECKED - LDC	CHECKED - LDC	REVISED -
PLOT DATE = 4/26/2014	DATE - April 29, 2014	DATE - April 29, 2014	REVISED -

**STATE OF ILLINOIS  
DEPARTMENT OF TRANSPORTATION**

**TRAFFIC SIGNAL INSTALLATION PLAN  
PROPOSED RIEDER ROAD AND PROPOSED RAMPS C & D**

SCALE: 1"=20'    SHEET NO. 7 OF 18 SHEETS    STA. TO STA.

F.A.I. RTE.	SECTION	COUNTY	TOTAL SHEETS	SHEET NO.
64	09-00365-01-PV	ST. CLAIR	535	299
TR RTE. 222 (RIEDER ROAD)		CONTRACT NO. 97549		
ILLINOIS				

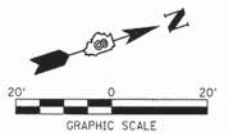
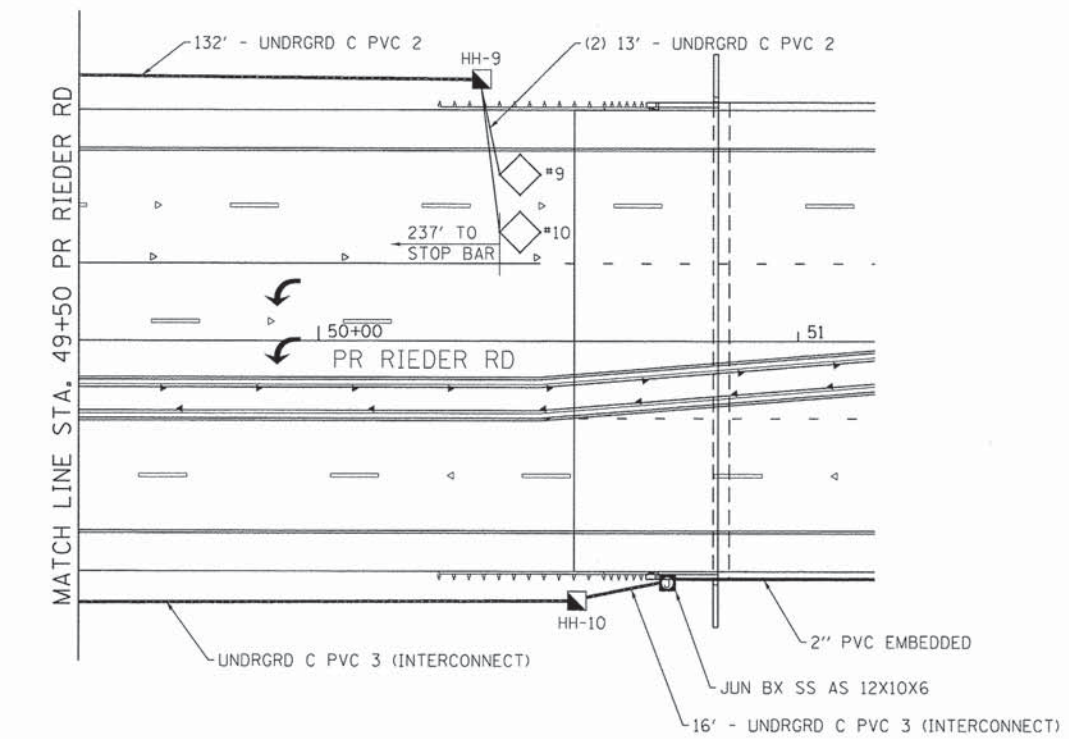
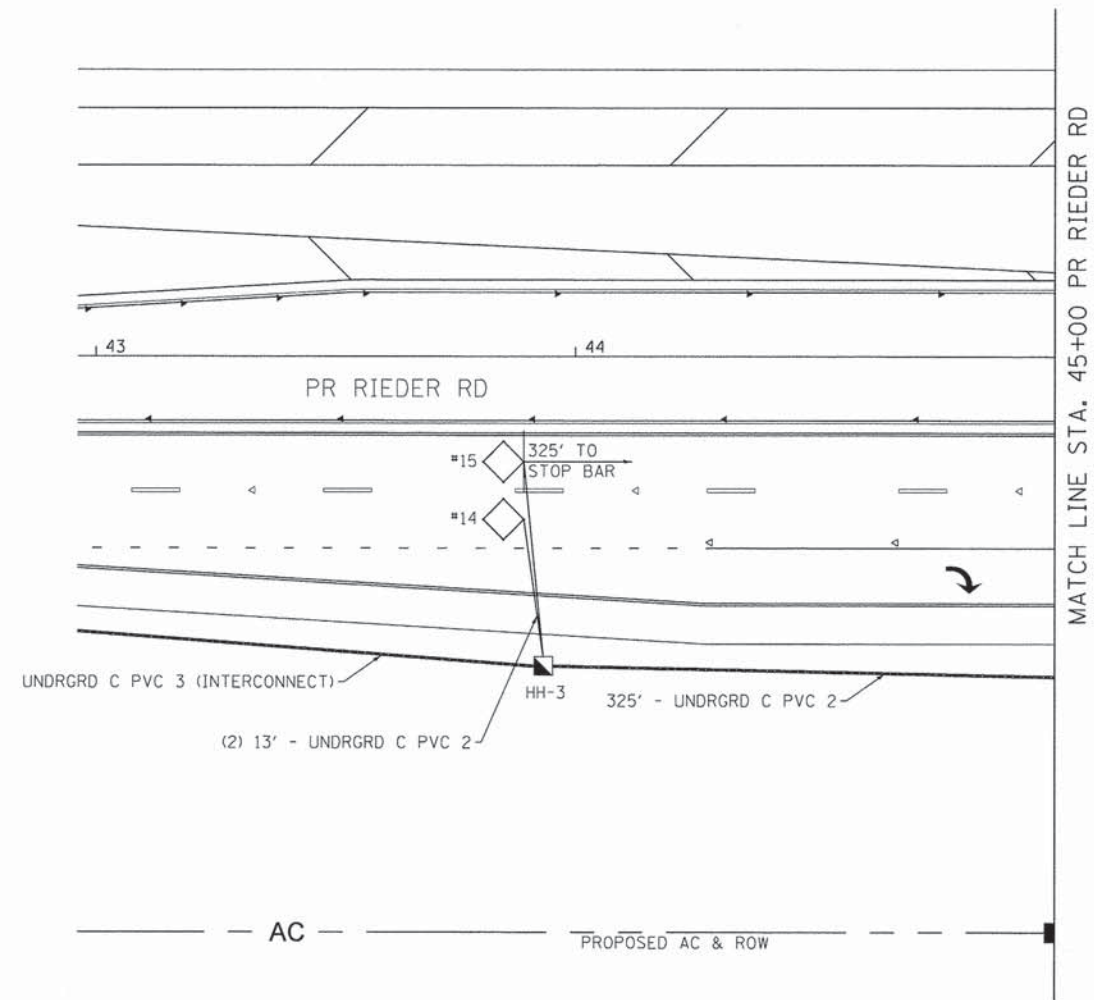

FILE NAME = 09-0016-sh1-15028.dgn

USER NAME = ID01  
 MODEL NAME = Default  
 PLOT SCALE = 240.0000' / ft.  
 PLOT DATE = 4/26/2014

DESIGNED - SMS  
 DRAWN - SMS  
 CHECKED - LDC  
 DATE - April 29, 2014

REVISED -  
 REVISED -  
 REVISED -  
 REVISED -

**STATE OF ILLINOIS  
 DEPARTMENT OF TRANSPORTATION**

**TRAFFIC SIGNAL INSTALLATION PLAN  
 PROPOSED RIEDER ROAD AND PROPOSED RAMPS C & D**

SCALE: 1"=20' SHEET NO. 8 OF 18 SHEETS STA. TO STA.

F.A.I. RTE.	SECTION	COUNTY	TOTAL SHEETS	SHEET NO.
64	09-00365-01-PV	ST. CLAIR	535	300
TR RTE. 222 (RIEDER ROAD)			CONTRACT NO. 97549	
ILLINOIS				

P:\09-0016-02-Rieder-Road-Phase-1\1118-CAD\CADD-Sheets\09-0016-sh1-15028.dgn