

STANDARD BAR SPLICER ASSEMBLY

Minimum Lap Lengths						
Bar size to be spliced	Table 1	Table 2	Table 3	Table 4	Table 5	Table 6
3, 4	1'-5"	1'-11"	2'-1"	2'-4"	2'-7"	2'-11"
5	1'-9"	2'-5"	2'-7"	2'-11"	3'-3"	3'-8"
6	2'-1"	2'-11"	3'-1"	3'-6"	3'-10"	4'-5"
7	2'-9"	3'-10"	4'-2"	4'-8"	5'-2"	5'-10"
8	3'-8"	5'-1"	5'-5"	6'-2"	6'-9"	7'-8"
9	4'-7"	6'-5"	6'-10"	7'-9"	8'-7"	9'-8"

- Table 1: Black bar, 0.8 Class C
- Table 2: Black bar, Top bar lap, 0.8 Class C
- Table 3: Epoxy bar, 0.8 Class C
- Table 4: Epoxy bar, Top bar lap, 0.8 Class C
- Table 5: Epoxy bar, Class C
- Table 6: Epoxy bar, Top bar top, Class C

Threaded splicer bar length = min. lap length + 1 1/2" + thread length

* Epoxy not required on Bar Splicer Assembly components used in conjunction with black bars.

Location	Bar size	No. assemblies required	Table for minimum lap length
Approach Slabs	#4	50	Table 6
Approach Slabs	#5	172	Table 5
Abutments	#5	20	Table 6
Abutments	#6	10	Table 6
Abutments	#7	24	Table 6
Pier	#5	10	Table 6
Pier	#6	36	Table 6
Pier	#8	10	Table 5

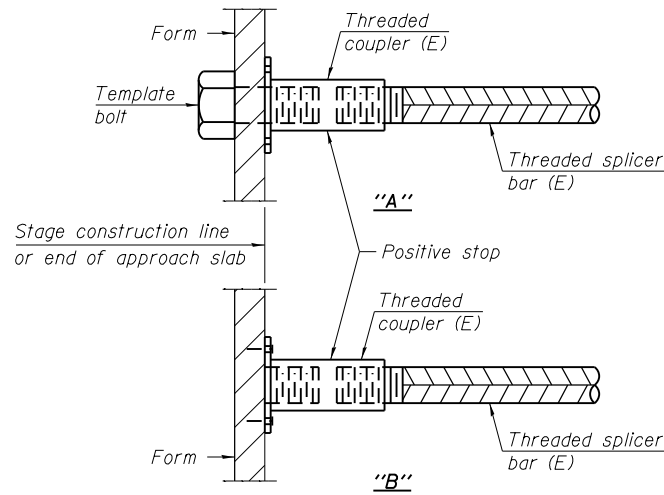

INSTALLATION AND SETTING METHODS

"A" : Set bar splicer assembly by means of a template bolt.
 "B" : Set bar splicer assembly by nailing to wood forms or cementing to steel forms.
 (E) : Indicates epoxy coating.

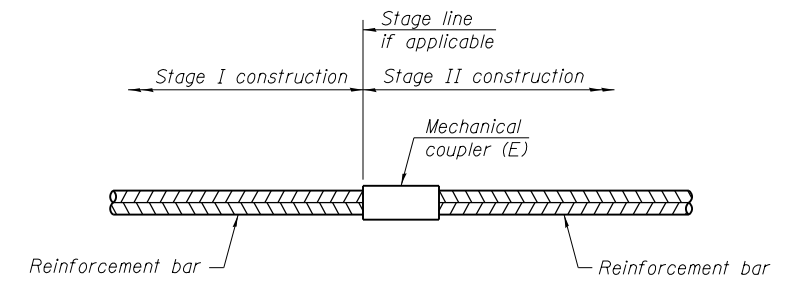

STANDARD MECHANICAL SPLICER

Location	Bar size	No. assemblies required

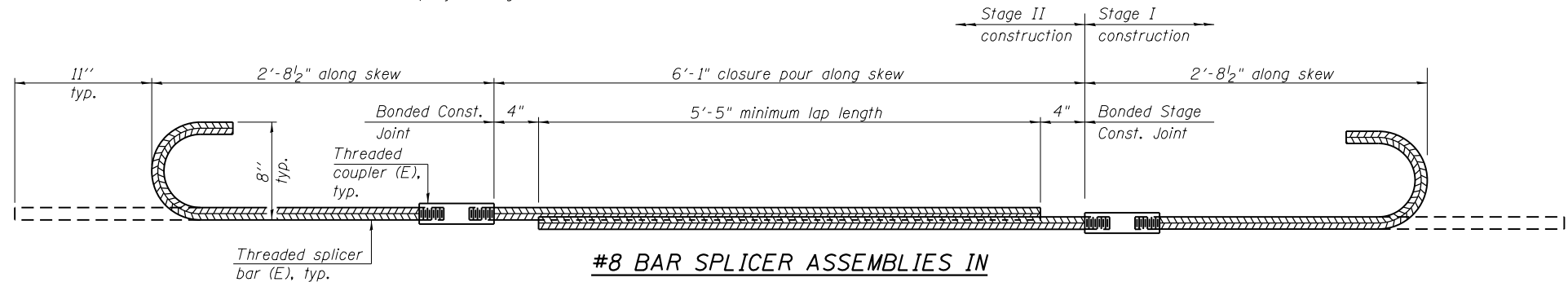

#8 BAR SPLICER ASSEMBLIES IN EDGE BEAMS AT DECK CLOSURE POUR

(Two bar splicer assemblies shown)
 No. required = 12

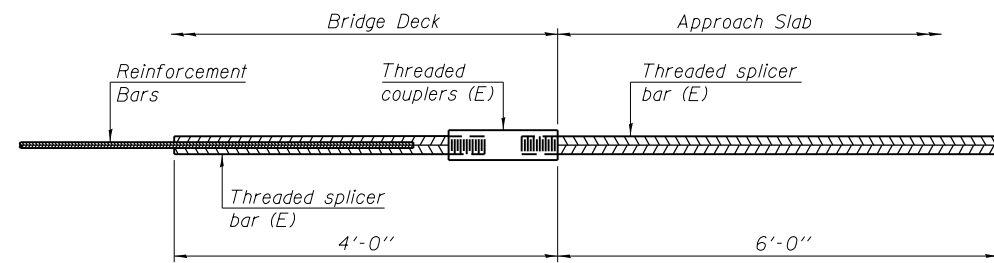

BAR SPLICER ASSEMBLY FOR #5 BAR ON INTEGRAL OR SEMI-INTEGRAL ABUTMENTS

No. required =

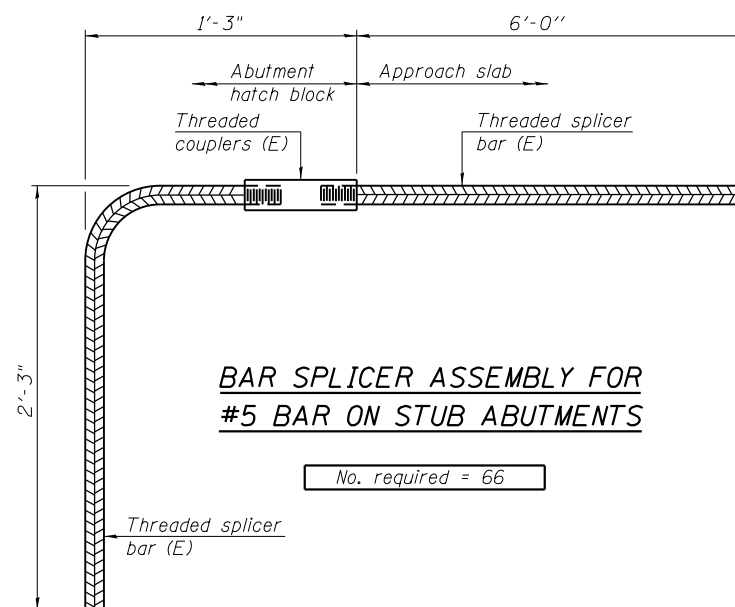

BAR SPLICER ASSEMBLY FOR #5 BAR ON STUB ABUTMENTS

No. required = 66

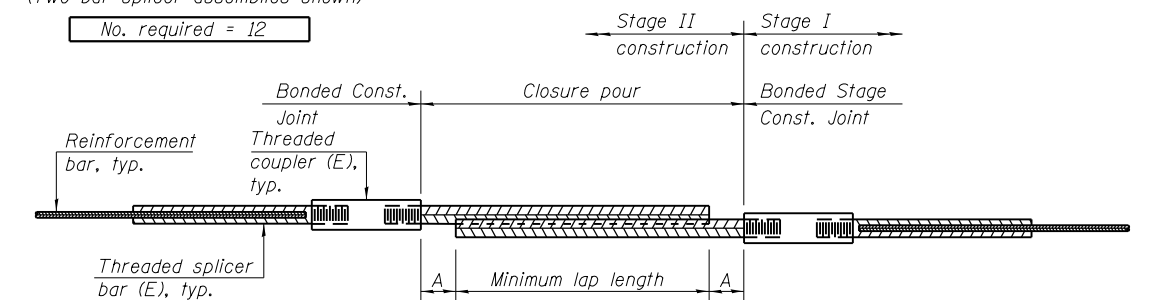

BAR SPLICER ASSEMBLIES AT DECK CLOSURE POUR

(Two bar splicer assemblies shown)

Bar size	No. assemblies required	Minimum lap length	Dim. "A"
#5	1888	3'-3"	2 1/2"
#7	16	4'-2"	1 1/2"
#8	4	5'-5"	4"

NOTES

Splicer bars shall be deformed with threaded ends and have a minimum 60 ksi yield strength.
 All reinforcement shall be lapped and tied to the splicer bars.
 Bar splicer assemblies shall be epoxy coated according to the requirements for reinforcement bars. See Section 508 of the Standard Specifications.
 See approved list of bar splicer assemblies and mechanical splicers for alternatives.

2/21/13 PM

3/29/2013

S:\1072_05_CADD\Structure\1 SN 0162470.CADD Sheet\162470-60J12-038-BS01.dgn