

TEMPORARY  
CONTROLLER SEQUENCE

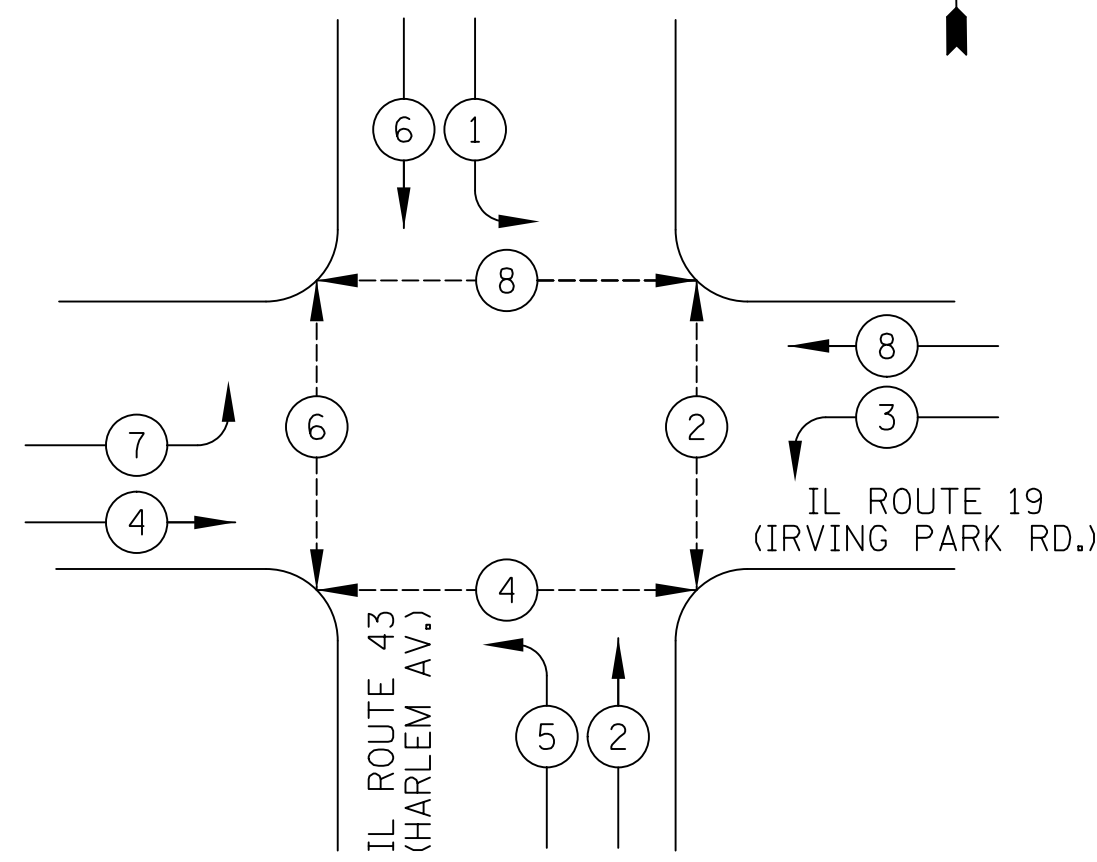

LEGEND

- DUAL ENTRY PHASE
- SINGLE ENTRY PHASE
- OVERLAP
- PEDESTRIAN PHASE
- NUMBER REFERS TO ASSOCIATED PHASE

I.D.O.T. TRAFFIC SIGNAL INSTALLATION ELECTRICAL SERVICE REQUIREMENTS					TOTAL WATTAGE
TYPE	NO. LAMPS	WATTAGE		% OPERATION	
		INCAND.	LED		
SIGNAL (RED)	12		17	0.50	102
(YELLOW)	12		25	0.25	75
(GREEN)	12		15	0.25	45
ARROW	16		12	0.10	19
PED. SIGNAL	8		25	1.00	200
VIDEO SYSTEM	1		150	1.00	150
CONTROLLER	1		100	1.00	100
TOTAL =					691
ENERGY COSTS TO: ILLINOIS DEPARTMENT OF TRANSPORTATION 201 WEST CENTER COURT SCHAUMBURG, IL 60196-1096					
ENERGY SUPPLY: CONTACT: PHONE: COMPANY:					

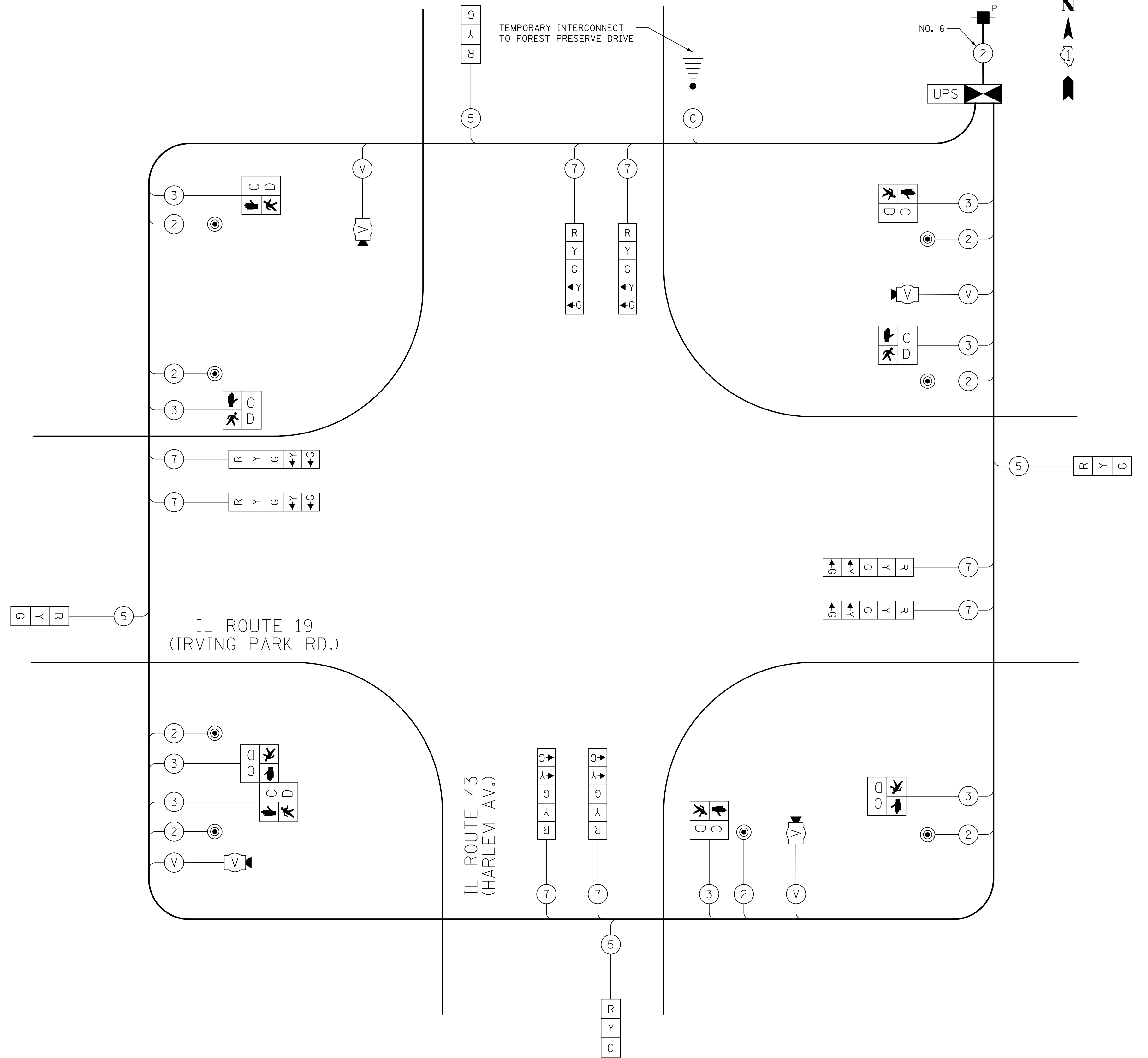

TEMPORARY CABLE PLAN  
NOT TO SCALE



USER NAME = mfb  
PLOT SCALE = 20.0000' / in.  
PLOT DATE = 3/20/2013

DESIGNED - BRD  
DRAWN - MFB  
CHECKED - JJE  
DATE - 03/21/2013

REVISED -  
REVISED -  
REVISED -  
REVISED -

STATE OF ILLINOIS  
DEPARTMENT OF TRANSPORTATION

TEMPORARY CABLE PLAN AND TEMPORARY PHASE DESIGNATION DIAGRAM  
IL ROUTE 19 (IRVING PARK RD.) AT IL ROUTE 43 (HARLEM AV.)

NOT TO SCALE SHEET NO. 1 OF 1 SHEETS STA. TO STA.

F.A.P. RTE.	SECTION	COUNTY	TOTAL SHEETS	SHEET NO.
0348	2012-041TS	COOK	34	21
CONTRACT NO. 60T97				
ILLINOIS FED. AID PROJECT				