

E-1 EXISTING TYPICAL SECTION
STA. 104+30.00 TO 116+70.00, ILLINOIS ROUTE 47

- EXISTING LEGEND**
- (A) HOT-MIX ASPHALT SURFACE COURSE, 1 3/4"
 - (B) HOT-MIX ASPHALT BINDER COURSE, 2 1/4"
 - (C) CRC PAVEMENT, 8"
 - (D) STABILIZED SUB BASE, 4"
 - (E) HOT-MIX ASPHALT SHOULDERS, 8"
 - (F) GRASS MEDIAN
 - (G) HOT-MIX ASPHALT SURFACE COURSE, 1 1/2"
 - (H) HOT-MIX ASPHALT BINDER COURSE, 3"
 - (I) AGGREGATE BASE COURSE, TYPE B, 12"
 - (J) AGGREGATE SHOULDERS, TYPE B, 6"

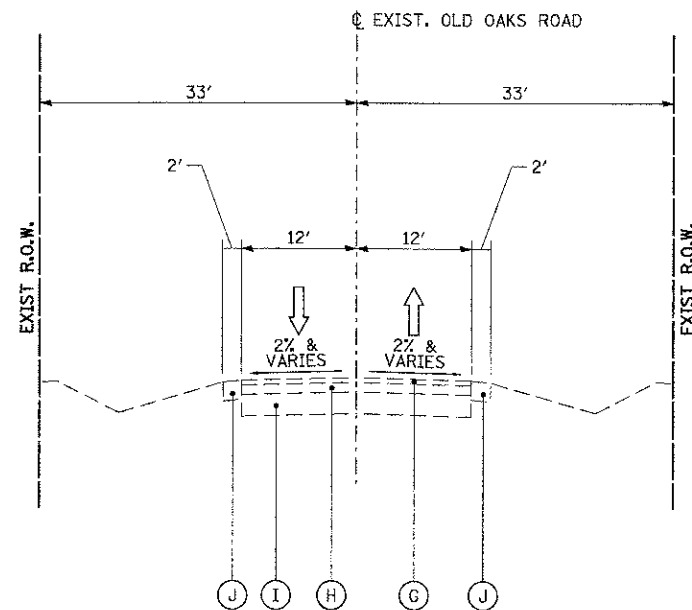

E-2 EXISTING TYPICAL SECTION
STA. 11+17.65 TO 15+53.82, OLD OAKS ROAD

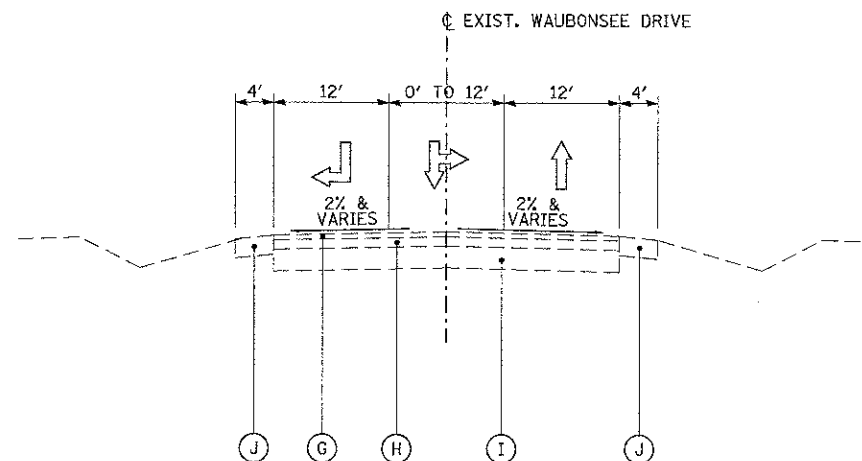

E-3 EXISTING TYPICAL SECTION
STA. 15+53.82 TO 20+16.27, WAUBONSEE DRIVE

NOTES:

1. EXISTING DIMENSIONS AND THICKNESSES ARE SHOWN FROM RECORD PLANS AND FIELD SURVEY, ACTUAL DIMENSIONS AND THICKNESSES MAY VARY.
2. NO ADDITIONAL COMPENSATION WILL BE ALLOWED TO THE CONTRACTOR BECAUSE OF VARIATION FROM THE THICKNESS SHOWN ON THE PLANS. THIS REQUIREMENT SHALL NOT BE A CAUSE FOR CLAIMING DELAY.

PATRICK ENGINEERING INC. 4870 VARSITY DRIVE LISLE, IL 60532 patrickengineering.com	USER NAME = #USER#	DESIGNED - MJP	REVISED -	STATE OF ILLINOIS DEPARTMENT OF TRANSPORTATION	ILLINOIS ROUTE 47 AT WAUBONSEE DRIVE EXISTING TYPICAL SECTIONS			F.A.P. RTE.	SECTION	COUNTY	TOTAL SHEETS	SHEET NO.
	PLOT CONFIG = #PLTDVRS#	DRAWN - JAC	REVISED -		326	11-00001-00-CH	KANE	55	8			
PLOT SCALE = #SCALESHT#	CHECKED - JAH	REVISED -										
PLOT DATE = #DATE# #TIME#	DATE - 3/25/2013	REVISED -			SCALE: N/A	SHEET TYP 1 OF 2	STA. TO STA.	FED. ROAD DIST. NO.	ILLINOIS FED. AID PROJECT	CONTRACT NO. 63829		