

NOTE:
LENGTH = 10' UNLESS
OTHERWISE NOTED ON PLANS.

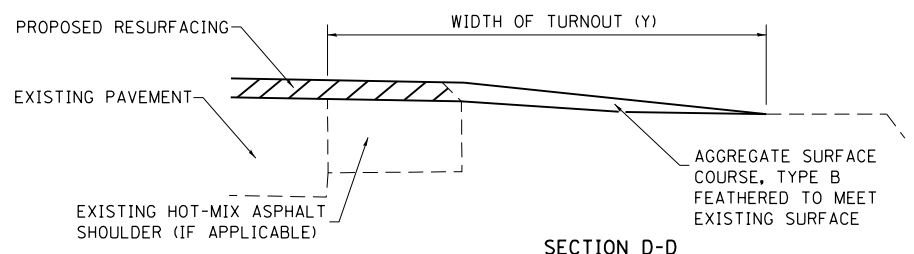
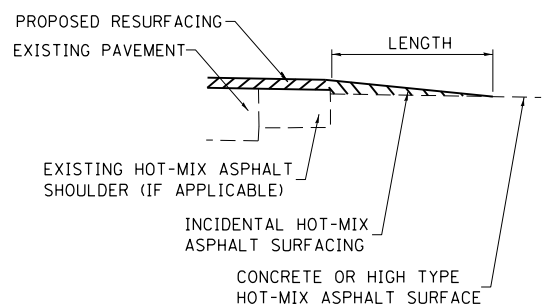
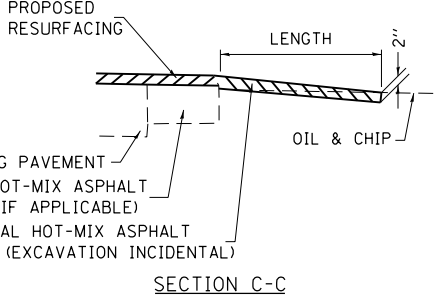
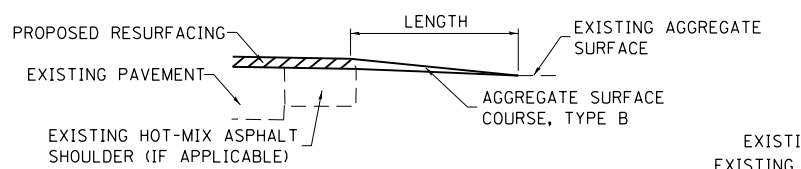
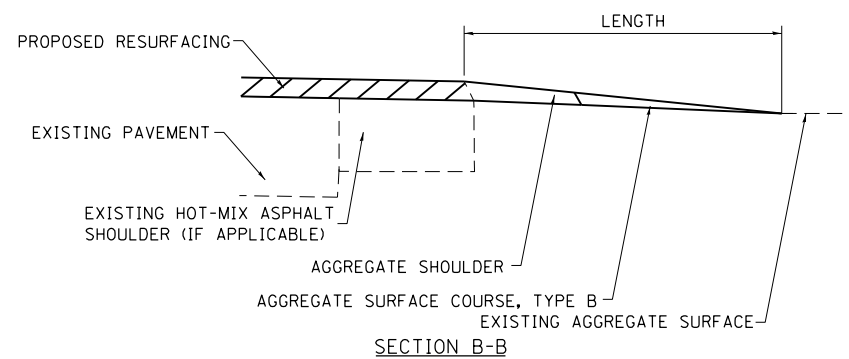

TYPICAL SECTION AT MAILBOX TURNOUT

NOTE: SEE STANDARD 406201 FOR MAILBOX TURNOUT DETAILS

NOTES

THE COST OF EXCAVATION IS INCLUDED IN THE PAY ITEM INCIDENTAL HOT-MIX ASPHALT SURFACING.

IF THERE IS NOT EXISTING HOT-MIX ASPHALT SHOULDER THEN THE ENTRANCE TAPER STARTS AT THE EDGE OF EXISTING PAVEMENT.

THE COST OF THE BITUMINOUS MATERIALS AND AGGREGATE (PRIME COAT) FOR ENTRANCES AND PUBLIC ROAD APPROACHES SHALL BE INCLUDED IN THE PAY ITEM INCIDENTAL HOT-MIX ASPHALT SURFACING.

SIDE	STATION	TYPE	INCIDENTAL HOT-MIX ASPHALT SURFACING	
			TON	TON
LT	517+38	CE	4.5	
LT	517+97	CE	3.3	
LT	518+77	PRA	3.9	
LT	6+08	PE	2.9	
LT	7+10	PE	3.1	
LT	8+36	PE	2.6	
LT	8+75	PRA	3.3	
LT	9+25	CE	3.1	
LT	9+85	CE	4.0	
LT	12+42	PRA	2.8	
LT	14+47	PE	1.6	
RT	14+47	FE		1.6
LT	15+37	PE	3.3	
LT	18+43	CE	3.7	
LT	22+83	CE	7.2	
LT	29+12	CE	17.5	
LT	45+04	PE	2.9	
LT	49+15	PE	2.6	
RT	59+25	FE	2.5	
LT	75+85	FE	0.5	0.7
LT	128+00	PE	5.1	
LT	128+90	PE	4.7	
LT	129+10	PE	2.2	
LT	130+13	PE	4.2	
LT	131+83	PE	4.6	
LT	133+38	PE	2.9	

SIDE	STATION	TYPE	INCIDENTAL HOT-MIX ASPHALT SURFACING	
			TON	TON
LT	133+97	CE	5.5	
LT	135+23	CE	4.3	
LT	136+00	CE	3.1	
LT	144+26	CE	11.4	
LT	145+49	FE	3.6	
LT	184+73	FE	2.4	
LT	187+66	FE	0.5	0.5
LT	195+16	PE	3.3	
LT	196+39	FE	0.6	0.8
LT	197+96	PRA	6.2	
LT	219+05	FE	1.8	
LT	219+62	FE	3.2	
LT	233+37	PRA	6.1	
RT	233+37	PRA	9.2	
RT	235+09	FE		4.2
LT	244+86	FE	3.9	
RT	258+16	FE		1.4
LT	266+83	FE	1.1	1.5
LT	289+78	PRA	5.7	
RT	289+80	PRA	5.5	
LT	326+77	FE	0.9	1.3
LT	346+40	PRA	6.5	
RT	346+40	PRA	5.0	
LT	360+48	FE	1.2	1.3
LT	374+56	FE	1.1	1.3
LT	107+89	PRA	5.1	

SIDE	STATION	TYPE	INCIDENTAL HOT-MIX ASPHALT SURFACING	
			TON	TON
RT	108+00	PRA	4.8	
LT	133+00	FE	0.9	1.1
RT	133+16	FE	1.1	1.3
LT	148+19	PRA	5.3	
RT	148+19	PRA	17.2	
LT	161+73	FE	1.0	1.1
RT	161+73	FE	1.1	1.3
LT	182+18	PE	4.5	
RT	190+93	PRA	19.7	
LT	191+01	PRA	6.0	
LT	511+77	PRA	5.5	
RT	511+77	PRA	5.3	
LT	525+78	FE	1.1	1.3
LT	538+21	FE	1.2	1.4
LT	565+04	PRA	4.8	
RT	565+04	PRA	5.3	
LT	593+76	FE	1.1	1.5
LT	617+98	PRA	4.5	
RT	617+98	PRA	4.3	
	TOTALS		291.0	24.0

FE=FIELD ENTRANCE PRA - PUBLIC ROAD APPROACH
PE=PRIVATE ENTRANCE MBT - MAILBOX TURNOUT
CE=COMMERCIAL ENTRANCE

FILE NAME =	USER NAME = steffenmk	DESIGNED - 08-03-99	REVISED - 03-13-07
ca:\pw\work\p\dot\steffenmk\d0249325\d74511-shit-sch.dgn		DRAWN -	REVISED -
	PLOT SCALE = 100.0000' / 1"	CHECKED -	REVISED -
	PLOT DATE = 10/2/2012	DATE -	REVISED -

**STATE OF ILLINOIS
DEPARTMENT OF TRANSPORTATION**

**RURAL ENTRANCE SCHEDULE AND MAILBOX TURNOUT DETAILS
WITH SHOULDERS**

SCALE: NA SHEET NO. 1 OF 1 SHEETS STA. TO STA.

F.A.P. RTE.	SECTION	COUNTY	TOTAL SHEETS	SHEET NO.
824	(19,20)RS-4	COLES	56	23
CONTRACT NO. 74511				
FED. ROAD DIST. NO. ILLINOIS FED. AID PROJECT				