

**PUBLIC ROAD**

**COMMERCIAL (P.C.C.)**

**COMMERCIAL (HOT-MIX ASPHALT)**

**PRIVATE ENTRANCE (P.C.C.)**

**PRIVATE ENTRANCE (HOT-MIX ASPHALT)**

**FIELD ENTRANCE (AGGREGATE)**

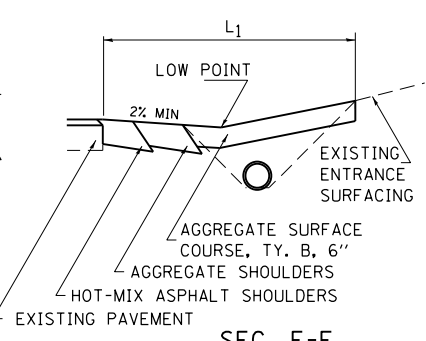
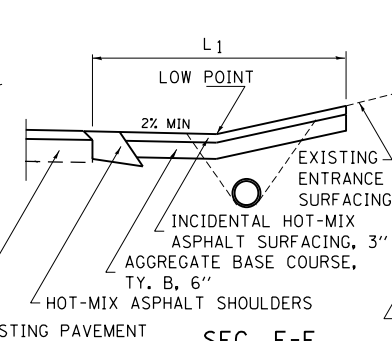
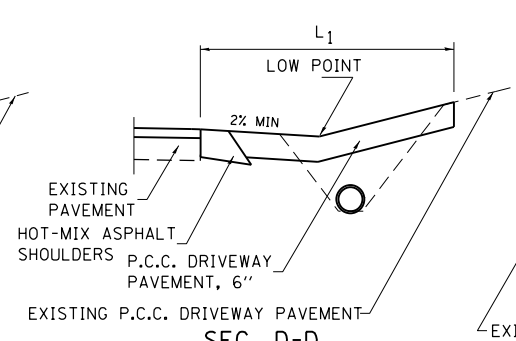
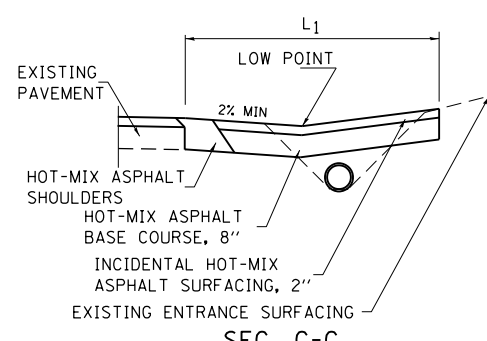
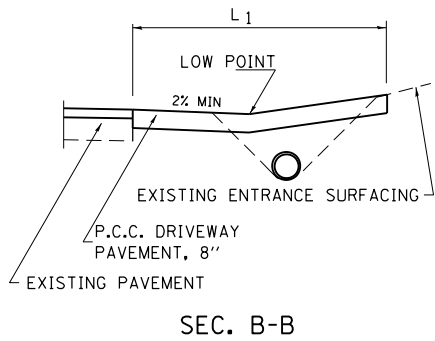
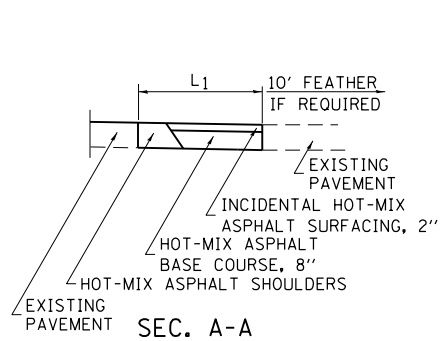
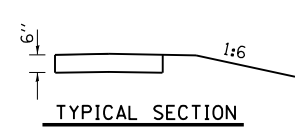
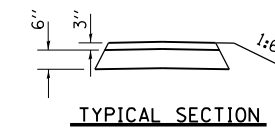
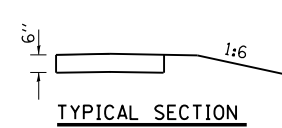
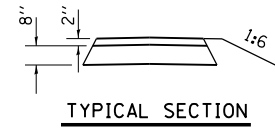
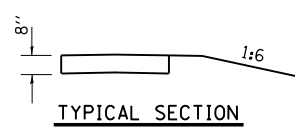
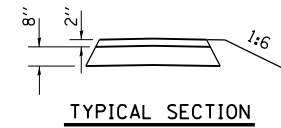

**ENTRANCE SCHEDULE**

TYPE	SIDE/ STATION	WIDTH	LENGTH		RADII	AGGREGATE BASE COURSE, TY. B, 6"				P.C.C. DRIVEWAY PAVEMENT	PCC PAVEMENT 8"	
			L <sub>1</sub>	L <sub>2</sub>		TON	SO. YD.	TON	TON			
												6"
PE	RT 811+27	12	15	15	15	14.1			6.9			
MB	LT 811+27					6.9			3.4			
MB	LT 815+46					4.7			2.3			
PE	LT 815+46	12	10	32	10	18.3			15.0			
CE	RT 815+82	35	20	11	20			119.9	1.5			
FE	LT 823+76	13	15	31	15				23.0			
FE	RT 823+80	14	15	33	15				25.3			
CE	LT 1018+07	24	20	20	15			89.8	1.1			
<b>TOTALS</b>						44.0		210.0	48.0	30.0		

**ENTRANCE SCHEDULE**

TYPE	SIDE/ STATION	WIDTH	LENGTH		RADII	AGGREGATE BASE COURSE, TY. B, 6"				P.C.C. DRIVEWAY PAVEMENT	PCC PAVEMENT 8"
			L <sub>1</sub>	L <sub>2</sub>		TON	SO. YD.	TON	TON		

**NOTES**

L<sub>1</sub> = DISTANCE FROM EDGE OF PAVEMENT TO RADIUS POINT OR MAXIMUM DISTANCE OF 30'.  
 L<sub>2</sub> = DISTANCE FROM RADIUS POINT OR MAXIMUM DISTANCE OF 30' FROM EDGE OF PAVEMENT TO R.O.W. LINE  
 MATERIAL USED TO CONSTRUCT L<sub>2</sub> LENGTH SHALL BE THE SAME TYPE OF MATERIAL AS THE EXISTING ENTRANCE

THE THICKNESS OF THE HOT-MIX ASPHALT SHOULDERS THROUGH COMMERCIAL ENTRANCES (HOT-MIX ASPHALT) AND PUBLIC ROADS SHALL BE 10". THE COST OF THE EXTRA THICKNESS SHALL BE INCLUDED WITH THE HOT-MIX ASPHALT SHOULDERS PAY ITEM.

THE COST OF THE BITUMINOUS MATERIALS AND AGGREGATE (PRIME COAT) FOR ENTRANCES AND PUBLIC ROAD APPROACHES SHALL BE INCLUDED IN THE PAY ITEM INCIDENTAL HOT-MIX ASPHALT SURFACING.

HOT-MIX ASPHALT SHOULDERS SHALL NOT BE CONSTRUCTED THROUGH PCC ENTRANCE OR PUBLIC ROAD APPROACH.

FE=FIELD ENTRANCE PRA - PUBLIC ROAD APPROACH  
 PE=PRIVATE ENTRANCE MBT - MAILBOX TURNOUT  
 CE=COMMERCIAL ENTRANCE

FILE NAME =	USER NAME = steffenmk	DESIGNED - ---	REVISED - 03-13-07
ei:\pw\work\p\dot\steffenmk\d030911\d774567-shd-sch.dgn		DRAWN -	REVISED -
	PLOT SCALE = 100.0000' / 1"	CHECKED -	REVISED -
	PLOT DATE = 3/18/2013	DATE -	REVISED -

**STATE OF ILLINOIS  
DEPARTMENT OF TRANSPORTATION**

**ENTRANCE SCHEDULE AND MAILBOX TURNOUT DETAILS  
WITH BASE COURSE WIDENING**

SCALE: N/A SHEET NO. 1 OF 1 SHEETS STA. TO STA.

F.A.P. RTE.	SECTION	COUNTY	TOTAL SHEETS	SHEET NO.
116	126N	EDWARDS	71	17
CONTRACT NO. 74567				
FED. ROAD DIST. NO. ILLINOIS FED. AID PROJECT				