

SHOULDER TRANSITION DETAIL

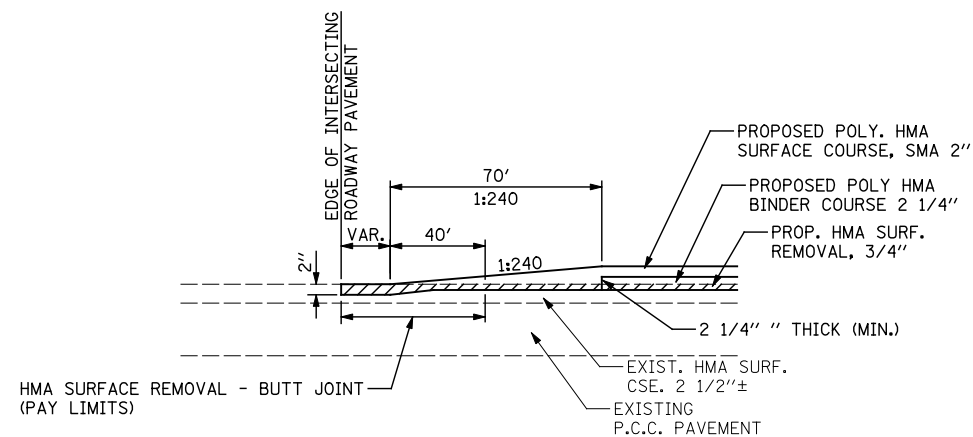

HMA SURFACE REMOVAL - BUTT JOINT DETAIL
(IL 4 RAMPS)

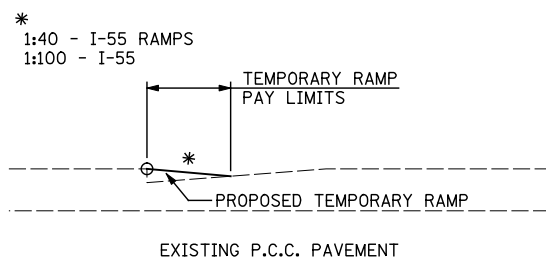

TEMPORARY RAMP DETAIL

NOTES:
THE TEMPORARY RAMP SHALL BE CONSTRUCTED IMMEDIATELY UPON REMOVAL OF THE EXISTING HMA SURFACE.

INSTALLATION AND REMOVAL OF THE TEMPORARY RAMP WILL BE PAID FOR AS "TEMPORARY RAMP".

TEMPORARY RAMPS CONSTRUCTED ON I-55 AT THE 1:100 TAPER RATE SHALL BE CONSTRUCTED USING A STRING LINE TO THE SATISFACTION OF THE ENGINEER BEFORE USED BY TRAFFIC.

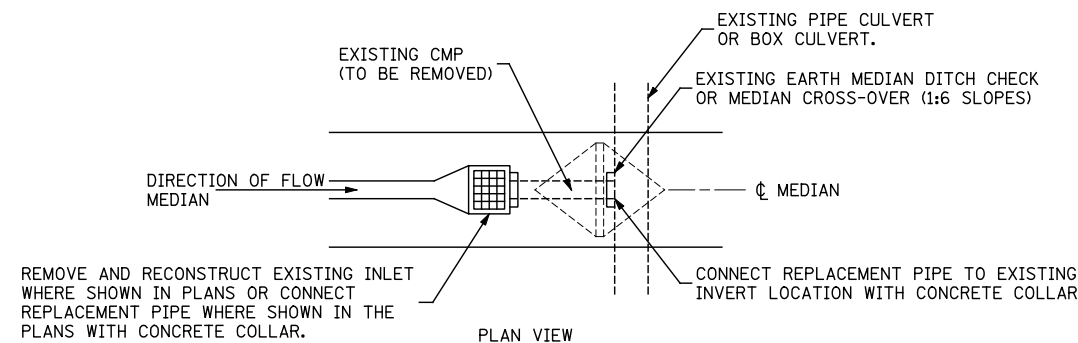

PLAN VIEW

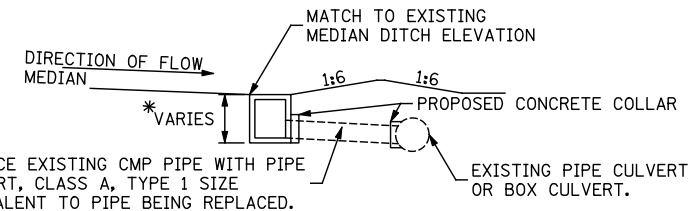

PROFILE VIEW

* MATCH DEPTH OF EXISTING INLET INVERT.

① DETAIL FOR REPLACING EXISTING INLET (STD. 542546) & CONNECTING PIPE

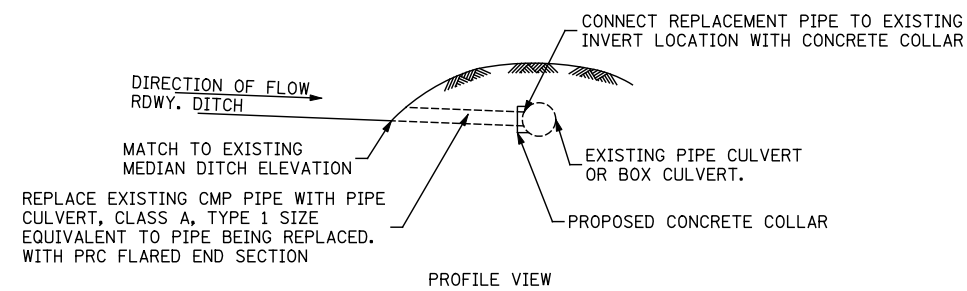

PROFILE VIEW

② DETAIL FOR REPLACING EXISTING ROADWAY DITCH CMP PIPES

FILE NAME =	USER NAME = \$(USER)	DESIGNED -	REVISED -
...\\CADD\0876D99-Sht-Details.dgn		DRAWN -	REVISED -
	PLOT SCALE = 100.0000' / IN.	CHECKED -	REVISED -
	PLOT DATE = 02/02/2012 18:22:44	DATE -	REVISED -



STATE OF ILLINOIS
DEPARTMENT OF TRANSPORTATION

JOINT DETAILS AND TEMPORARY RAMP DETAIL
PIPE CULVERT REPLACEMENT DETAILS

SCALE: SHEET NO. 1 OF 2 SHEETS STA. TO STA.

F.A.I. RTE.	SECTION	COUNTY	TOTAL SHEETS	SHEET NO.
55	60-(1,2)RS-3	MADISON	212	116
CONTRACT NO. 76D99				
ILLINOIS FED. AID PROJECT				