

LEGEND

- ① EXISTING AGGREGATE BASE
- ② EXISTING BITUMINOUS PAVEMENT
- ③ EXISTING AGGREGATE SHOULDER
- ④ POLYMERIZED LEVELING BINDER (MACHINE METHOD), IL-4.75, NSO 3/4"
- ⑤ HOT MIX ASPHALT SURFACE COURSE, MIX "C", NSO 2"
- ⑥ HOT MIX ASPHALT SURFACE REMOVAL 1"
- ⑦ AGGREGATE WEDGE SHOULDER, TYPE B

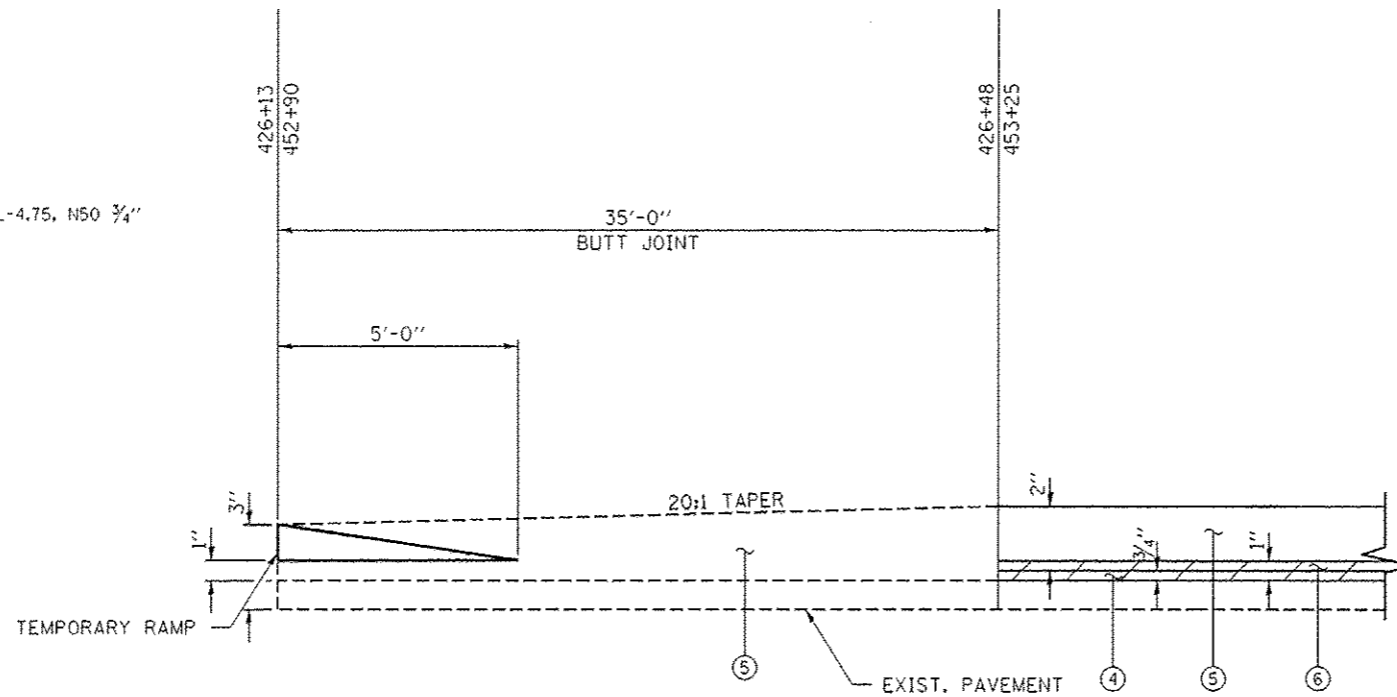

BUTT JOINT DETAIL

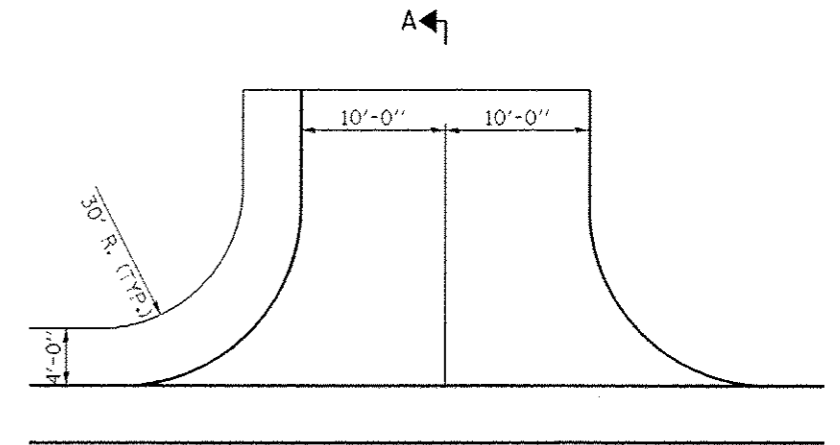

SIDEROAD DETAIL
L.I. STA. 452+84.13
R.T. STA. 452+84.13

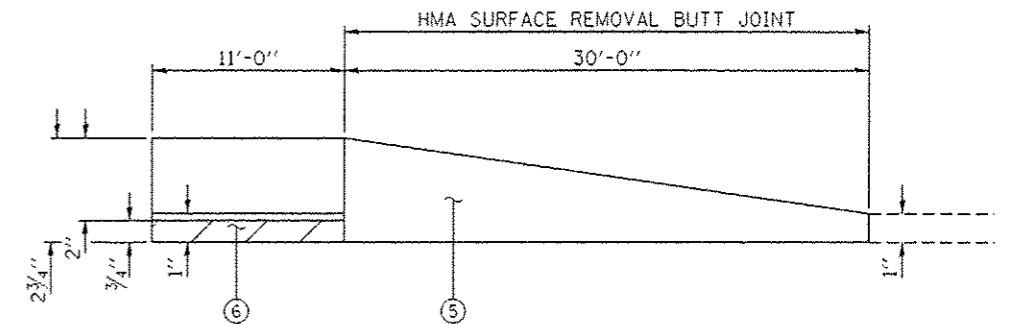

SECTION A-A

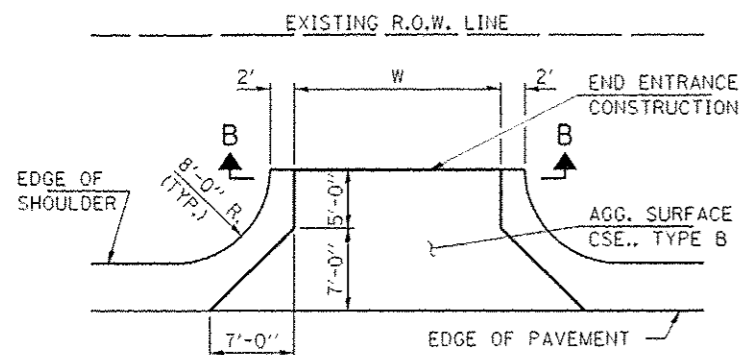

PRIVATE & FIELD ENTRANCE DETAIL

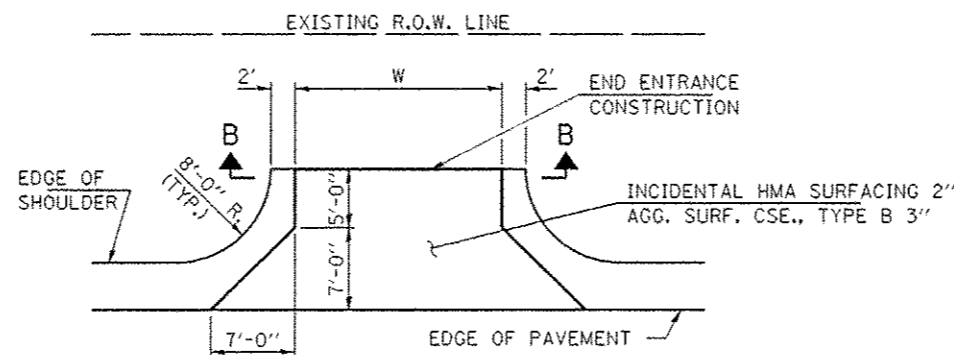

COMMERCIAL ENTRANCE DETAIL

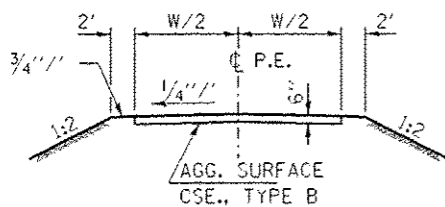

SECTION B-B

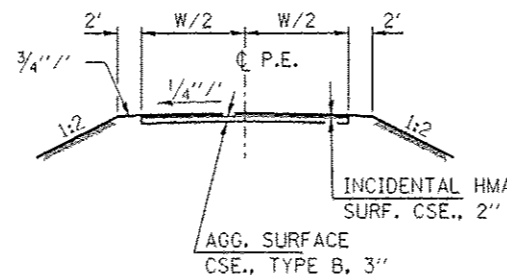

SECTION B-B

ENTRANCES						
LOCATION	TYPE	PROPOSED WIDTH	PROPOSED LENGTH	PROPOSED SURFACE	INCIDENTAL HMA SURFACING	AGGREGATE SURFACE COURSE TYPE B
		FEET	FEET		TON	TON
FAS 247/CH21/BRADFORD RD						
LT. STA 426+32	P.E.	16	12	AGG		9
RT. STA 427+02	P.E.	22	12	AGG		12
LT. STA 427+37	CE	30	12	HMA	5	8
LT. STA 428+87	CE	30	12	HMA	5	8
LT. STA 431+21	P.E.	16	12	AGG		9
LT. STA 434+83	P.E.	18	12	AGG		10
RT. STA 443+10	F.E.	16	12	AGG		9
TOTAL					10	65