

ROUTE	SECTION	COUNTY	TOTAL SHEETS	SHEET NO.
TR 239	06-08117-00-BR	SALINE	14	11
PROJECT NO. BROS-185(30)			CONTRACT NO. 99488	

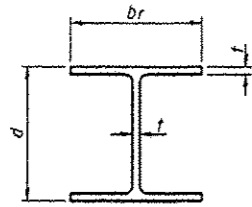

STEEL PILE TABLE

Designation	Depth <i>d</i>	Flange width <i>b_f</i>	Web and Flange thickness <i>t</i>	Encasement diameter <i>A</i>	Encasement Quantity/Ft. C.Y.
HP 14x117	14 1/4"	14 7/8"	1 1/16"	30"	0.173
x102	14"	14 3/4"	1/16"	30"	0.174
x89	13 7/8"	14 3/4"	5/8"	30"	0.175
x73	13 5/8"	14 5/8"	1/2"	30"	0.176
HP 12x84	12 1/4"	12 1/4"	1/16"	24"	0.110
x74	12 1/8"	12 1/4"	5/8"	24"	0.111
x63	12"	12 5/8"	1/2"	24"	0.112
x53	11 3/4"	12"	7/16"	24"	0.112
HP 10x57	10"	10 1/4"	9/16"	24"	0.112
x42	9 3/4"	10 5/8"	7/16"	24"	0.113
HP 8x36	8"	8 5/8"	7/16"	18"	0.063

Note: The steel H-piles shall be according to AASHTO M270 Grade 50.

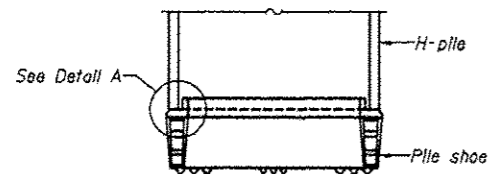

ELEVATION

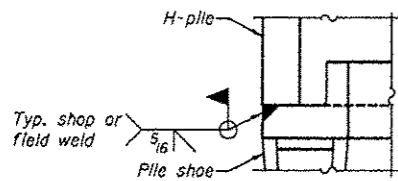

DETAIL A

H-PILE SHOE ATTACHMENT

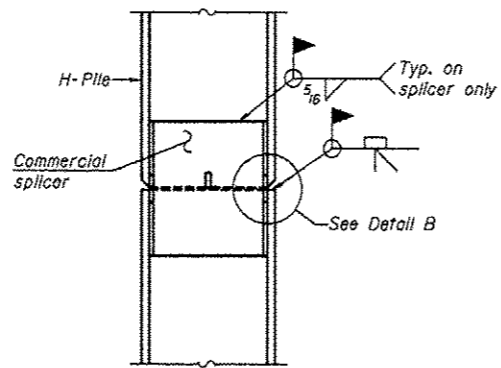

ELEVATION

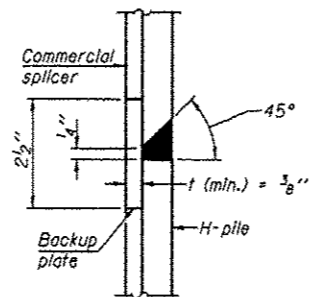

DETAIL "B"

WELDED COMMERCIAL SPLICE

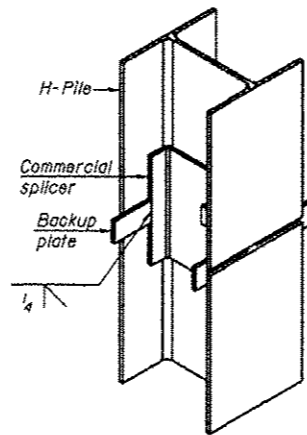

ISOMETRIC VIEW

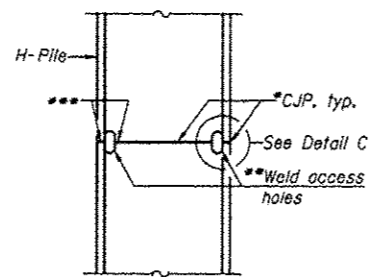

ELEVATION

COMPLETE PENETRATION WELD SPLICE

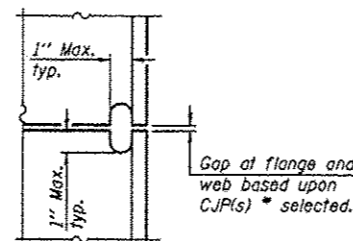

DETAIL C

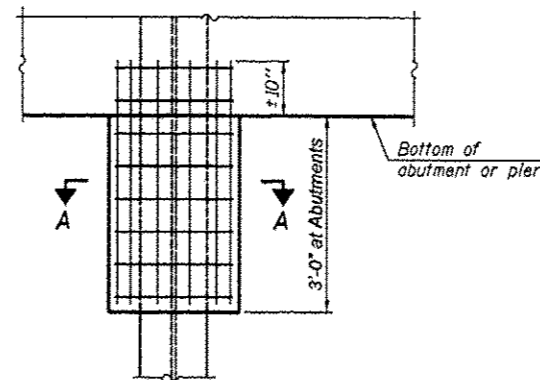

ELEVATION

PILE ENCASEMENT

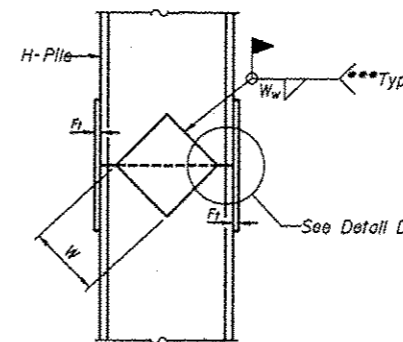

ELEVATION

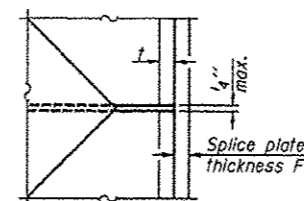

DETAIL D

WELDED PLATE FIELD SPLICE

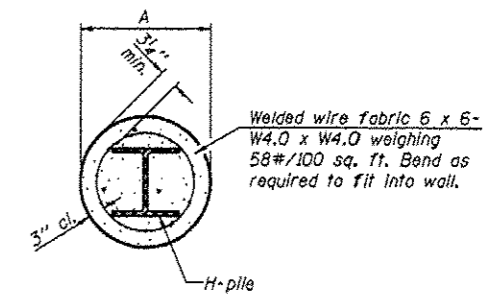

SECTION A-A

Note: Forms for encasement may be omitted when soil conditions permit.

Designation	F	F _t	F _w	W	W _t	W _w
HP 14x117	12 1/2"	1"	7/8"	7 3/4"	5 5/8"	1/2"
x102	12 1/2"	7/8"	3/4"	7 3/4"	5 5/8"	1/2"
x89	12 1/2"	3/4"	1/16"	7 3/4"	5 5/8"	1/2"
x73	12 1/2"	5/8"	9/16"	7 3/4"	5 5/8"	1/2"
HP 12x84	10"	7/8"	1/16"	6 1/2"	5 5/8"	1/2"
x74	10"	7/8"	1/16"	6 1/2"	5 5/8"	1/2"
x63	10"	5/8"	1/2"	6 1/2"	1/2"	3/8"
x53	10"	5/8"	1/2"	6 1/2"	1/2"	3/8"
HP 10x57	8"	3/4"	9/16"	5 1/4"	1/2"	3/8"
x42	8"	5/8"	9/16"	5 1/4"	1/2"	3/8"
HP 8x36	7"	5/8"	7/16"	4 1/4"	1/2"	3/8"

*Use joint conforming to Figure 3.4 in AWS D1.1, Structure Welding Code - Steel.

**Preparation per Fig. 5.2 In AWS D1.1, Structure Welding Code - Steel.

***Interrupt welds 1/4" from end of each pile.

PILING DETAILS
TOWNSHIP ROUTE 239 (BRIER CREEK ROAD)
BRIER CREEK
SECTION 06-06117-00-BR
SALINE COUNTY
STRUCTURE NO. 083-3237