

STATE OF ILLINOIS
DEPARTMENT OF TRANSPORTATION

F.A.P. RTE.	SECTION	COUNTY	TOTAL SHEETS	SHEET NO.
615/646	(116)CJS & (103,104)RS-6	BUREAU	10	1
		ILLINOIS	CONTRACT NO. 66J87	

INDEX OF SHEETS

- 1 COVER SHEET
- 2 GENERAL NOTES
- 3-4 SUMMARY OF QUANTITIES
- 5-6 TYPICAL SECTIONS
- 7-8 SCHEDULE OF QUANTITIES
- 9 LAYOUT MAP
- 10 DETAILS

LIST OF ILLINOIS DOT HIGHWAY STANDARDS

000001-07	STANDARD SYMBOLS, ABBREVIATIONS AND PATTERNS
001006	DECIMAL OF AN INCH AND OF A FOOT
701001-02	OFF-ROAD OPERATIONS 2L, 2W, MORE THAN 15' (4.5 m) AWAY
701006-05	OFF-ROAD OPERATIONS 2L, 2W, 15' (4.5 m) TO 24' (600 mm) FROM
701301-04	LANE CLOSURE, 2L, 2W, SHORT TIME OPERATIONS
701308-04	LANE CLOSURE, 2L, 2W, SLOW MOVING OPERATIONS DAY ONLY
701311-03	LANE CLOSURE, 2L, 2W, MOVING OPERATIONS - DAY ONLY
701501-06	URBAN LANE CLOSURE, 2L, 2W, UNDIVIDED
701901-08	TRAFFIC CONTROL DEVICES

PROPOSED HIGHWAY PLANS

FAP ROUTE 615 (IL 26), FAP ROUTE 646 (IL 40)
SECTION (116)CJS & (103,104)RS-6
PROJECT STP-8RAI(788)
CRACK AND JOINT SEALING AND MICROSURFACING
BUREAU COUNTY

BEGIN PROJECT
STA. 922 + 15

BRIDGE OMISSION
S.N. 006-0086
STA. 954+04 TO
STA. 955+08

BRIDGE OMISSION
S.N. 006-0156
STA. 1242+06 TO
STA. 1243+40

BRIDGE OMISSION
S.N. 006-0157
STA. 1266+13 TO
STA. 1267+38

END SECTION
STA 1420 + 00

C-93-071-19

BEGIN SECTION
STA. 108 + 23

END PROJECT
STA 151 + 05

GROSS LENGTH = 54,067 FT. = 10.240 MILE
NET LENGTH = 53,704 FT. = 10.171 MILE

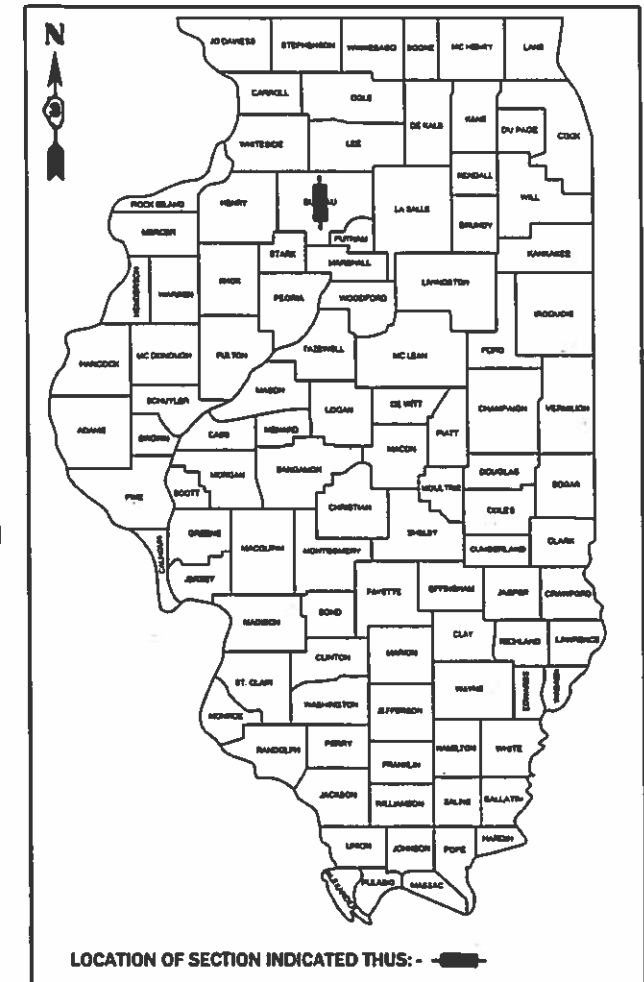

LOCATION OF SECTION INDICATED THUS: -

(IL 40)	(IL 26)
2017 ADT = 2,300	2017 ADT = 9,750
PV = 46%	PV = 91%
SU = 5%	SU = 7%
MU = 49%	MU = 2%

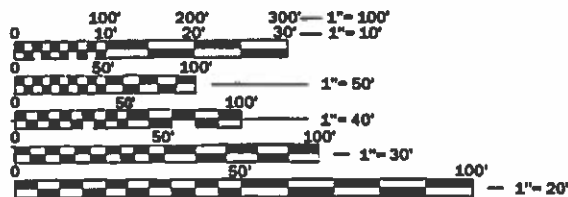

FULL SIZE PLANS HAVE BEEN PREPARED USING STANDARD ENGINEERING SCALES. REDUCED SIZED PLANS WILL NOT CONFORM TO STANDARD SCALES. IN MAKING MEASUREMENTS ON REDUCED PLANS, THE ABOVE SCALES MAY BE USED.

J.U.L.I.E.
JOINT UTILITY LOCATION INFORMATION FOR EXCAVATION
1-800-892-0123
OR 811

PROJECT ENGINEER: JOSEPH KANNEL P.E.
UNIT CHIEF: MICHELE LINDEMANN P.E.
DISTRICT 3 NO. (815) 434-6131
CONTRACT NO. 66J87

STATE OF ILLINOIS
DEPARTMENT OF TRANSPORTATION

SUBMITTED 3/22 2019
F. Mauch
REGIONAL ENGINEER

May 10 2019
cc E.A. ETC
ENGINEER OF DESIGN AND ENVIRONMENT

May 17 2019
David L. Chaf
DIRECTOR OF HIGHWAYS PROJECT IMPLEMENTATION

PRINTED BY THE AUTHORITY
OF THE STATE OF ILLINOIS

COMMITMENT

GENERAL NOTES

THE ENGINEER WILL BE THE SOLE JUDGE CONCERNING CURING TIME FOR THE MICRO-SURFACING AND THE TIMING FOR OPENING THE ROADWAY TO TRAFFIC

IT IS THE RESPONSIBILITY OF THE RESIDENT ENGINEER TO LOCATE ANY ADDITIONAL BUMPS AND CRACKS TO BE REMOVED OR SEALED PRIOR TO MICRO-SURFACING OPERATIONS.

NO QUANTITIES HAVE BEEN INCLUDED TO REPLACE PAVEMENT MARKINGS OR RAISED REFLECTIVE PAVEMENT MARKERS IN CRACK ROUTING AND SEALING AREAS. LONGITUDINAL CRACKS THAT CONFLICT WITH THE EXISTING PAVEMENT MARKINGS SHALL NOT BE SEALED. IF THE CONTRACTOR DAMAGES ANY REFLECTOR LENSES, HE/SHE SHALL REPLACE THEM AT HIS/HER EXPENSE.

ALL PCC BRIDGE DECKS AND PAVEMENTS SHALL BE OMITTED. BRIDGE DECKS WITH HMA OVERLAYS ARE TO BE SEALED ONLY (NO ROUTING)

ANY REFERENCE TO A STANDARD IN THESE PLANS SHALL BE INTERPRETED TO MEAN THE EDITION AS INDICATED BY THE SUBNUMBER SHOWN IN THE LIST OF STANDARDS OR THE COPY INCLUDED IN THESE PLANS

THE FOLLOWING RATES OF APPLICATION HAVE BEEN USED IN CALCULATING PLAN QUANTITIES:

SHORT TERM PAVEMENT MARKING	10	FT /100 FT OF APPLICATION
MIX FOR CRACKS, JTS & FLGWYS	0.0003	TONS / SQ YD
CRACK FILLING MATERIAL	0.35	POUNDS/FOOT

THE CONTRACTOR SHALL CONTACT JULIE AT LEAST 48 HOURS PRIOR TO EXCAVATION TO DETERMINE WHICH UTILITIES ARE IN THE AREA.

STATE OF ILLINOIS
DEPARTMENT OF TRANSPORTATION
DISTRICT THREE
AS BUILT INFORMATION

SUPERVISING CONSTRUCTION FIELD ENGINEER

RESIDENT ENGINEER / TECHNICIAN

START & END DATES
OF CONSTRUCTION:

INSPECTORS:

STATE OF ILLINOIS
DEPARTMENT OF TRANSPORTATION
DISTRICT THREE

PREPARED BY: *Don Benic*
DISTRICT STUDIES & PLANS ENGINEER

DATE: 3/22/19

EXAMINED BY: *KSV*
DISTRICT CONSTRUCTION ENGINEER

[Signature]
DISTRICT MATERIALS ENGINEER

[Signature]
DISTRICT OPERATIONS ENGINEER

FILE NAME =	USER NAME = corcoranim	DESIGNED -	REVISED -
c:\pw_work\pwidofcorcoranim\0602703\0366J87-shi-cover.dgn		DRAWN -	REVISED -
	PLOT SCALE = 100.0000' / in.	CHECKED -	REVISED -
\$MODELNAME\$	PLOT DATE = 3/14/2019	DATE -	REVISED -

STATE OF ILLINOIS
DEPARTMENT OF TRANSPORTATION

GENERAL NOTES

SCALE: SHEET OF SHEETS STA. TO STA.

F.A.P. RTE.	SECTION	COUNTY	TOTAL SHEETS	SHEET NO.
615/646	(116)CJS & (103,104)RS-2	BUREAU	10	2
CONTRACT NO. 66J87				
ILLINOIS FED. AID PROJECT				

CODE NO.	ITEM	UNIT	TOTAL QUANTITY	CONSTRUCTION CODE	
				80% FED 20% STATE ROADWAY	80% FED 20% STATE ROADWAY
				0005 URBAN	0005 RURAL
40400001	FIBER-MODIFIED ASPHALT CRACK SEALING	FOOT	3978		3978
40400020	BUMP REMOVAL	EACH	20		20
40400120	MICRO-SURFACING, SINGLE PASS, MIXTURE C	SQ YD	11365		11365
40600290	BITUMINOUS MATERIALS (TACK COAT)	POUND	2557		2557
40600400	MIXTURE FOR CRACKS, JOINTS, AND FLANGEWAYS	TON	3.4		3.4
45100100	CRACK ROUTING (PAVEMENT)	FOOT	10272	10272	
45100200	CRACK FILLING	POUND	3597	3597	
67100100	MOBILIZATION	L SUM	1	0.5	0.5
70100460	TRAFFIC CONTROL AND PROTECTION, STANDARD 701306	L SUM	1		1
70102620	TRAFFIC CONTROL AND PROTECTION, STANDARD 701501	L SUM	1	1	
70107025	CHANGEABLE MESSAGE SIGN	CAL DA	90		90
70300100	SHORT TERM PAVEMENT MARKING	FOOT	4979		4979
70300150	SHORT TERM PAVEMENT MARKING REMOVAL	SQ FT	1660		1660
70300220	TEMPORARY PAVEMENT MARKING - LINE 4"	FOOT	16935		16935

Δ SPECIALTY ITEMS

FILE NAME =	USER NAME = corcoranlm	DESIGNED -	REVISED -	STATE OF ILLINOIS DEPARTMENT OF TRANSPORTATION	SUMMARY OF QUANTITIES				F.A.P. RTE.	SECTION	COUNTY	TOTAL SHEETS	SHEET NO.
pw:\planroom\dot\illinois.gov\PWIDOT\Documents\DOT	Office\District 3\Projects\D366J87\CADData\D366J87-sht-cover.dwg	DRAWN -	REVISED -						615/646	(116)CJS & (103,104)RS-6	BUREAU	10	3
Default	PLOT SCALE = 100,0000' / in.	CHECKED -	REVISED -		CONTRACT NO. 66J87				ILLINOIS	FED. AID PROJECT			
	PLOT DATE = 3/22/2019	DATE -	REVISED -		SCALE:	SHEET	OF	SHEETS	STA.	TO STA.			

CODE NO.	ITEM	UNIT	TOTAL QUANTITY	CONSTRUCTION CODE	
				80% FED 20% STATE ROADWAY	80% FED 20% STATE ROADWAY
				0005 URBAN	0005 RURAL
70300240	TEMPORARY PAVEMENT MARKING - LINE 6"	FOOT	12446		12446
70300250	TEMPORARY PAVEMENT MARKING - LINE 8"	FOOT	527		527
Δ 78008210	POLYUREA PAVEMENT MARKING TYPE I - LINE 4"	FOOT	33870		33870
Δ 78008230	POLYUREA PAVEMENT MARKING TYPE I - LINE 6"	FOOT	24892		24892
Δ 78008240	POLYUREA PAVEMENT MARKING TYPE I - LINE 8"	FOOT	1054		1054
Δ 78100100	RAISED REFLECTIVE PAVEMENT MARKER	EACH	623		623
78300200	RAISED REFLECTIVE PAVEMENT MARKER REMOVAL	EACH	623		623
X0327980	PAVEMENT MARKING REMOVAL - WATER BLASTING	SQ FT	44604		44604
Z0030850	TEMPORARY INFORMATION SIGNING	SQ FT	42	42	

Δ SPECIALTY ITEMS

FILE NAME =	USER NAME = corcoranlm	DESIGNED -	REVISED -	STATE OF ILLINOIS DEPARTMENT OF TRANSPORTATION	SUMMARY OF QUANTITIES				F.A.P. RTE.	SECTION	COUNTY	TOTAL SHEETS	SHEET NO.
pw:\planroom\dot\illinois.gov\PWIDOT\Documents\IDOT	Office\District 3\Projects\D366J87\CADData\D366J87-sht-cover.dwg	DRAWN -	REVISED -						615/646	(116)CJS & (103.104)RS-6	BUREAU	10	4
Default	PLOT SCALE = 100.0000' / in.	CHECKED -	REVISED -		CONTRACT NO. 66J87				ILLINOIS	FED. AID PROJECT			
	PLOT DATE = 3/22/2019	DATE -	REVISED -		SCALE:	SHEET	OF	SHEETS	STA.	TO STA.			

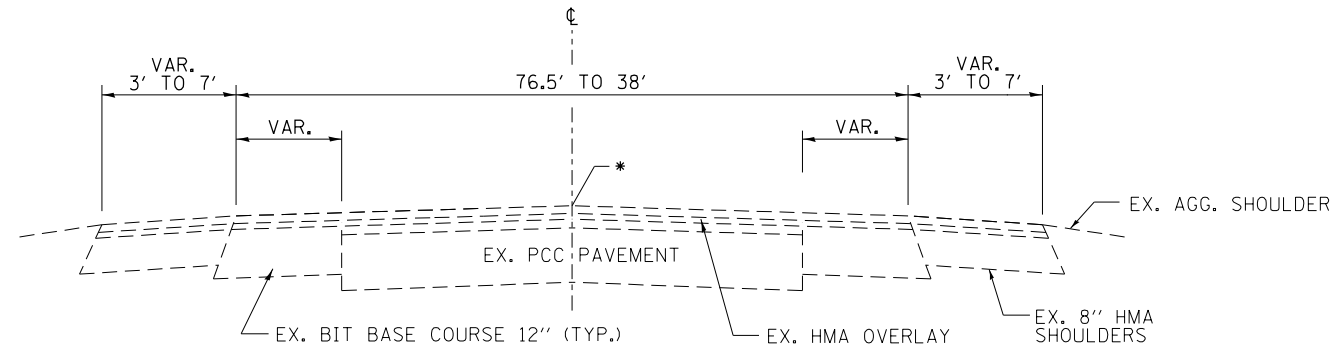

TYPICAL SECTION IL 26

STA. 108+22.70 TO STA. 114+53
PROP CRACK SEALING - SEE DETAIL

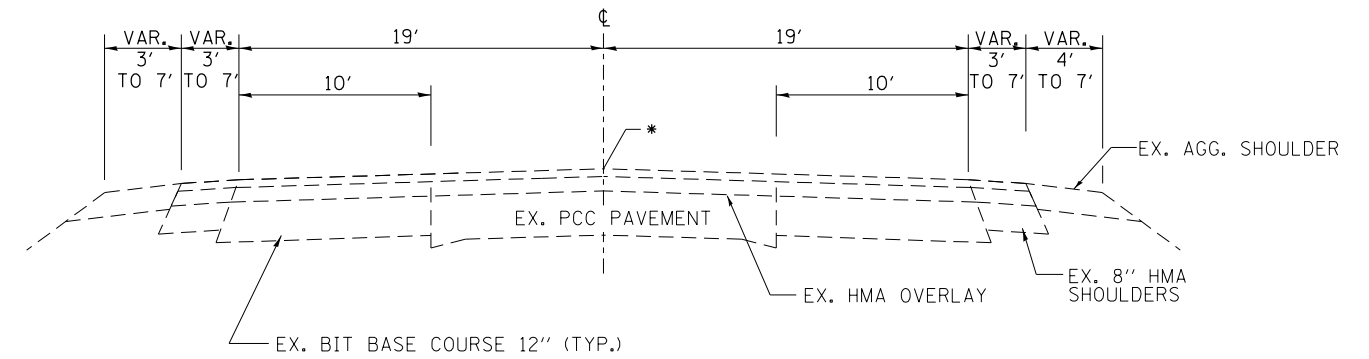

TYPICAL SECTION IL 26

STA. 114+53 TO STA. 122+57
PROP CRACK SEALING - SEE DETAIL

* CRACK SEAL

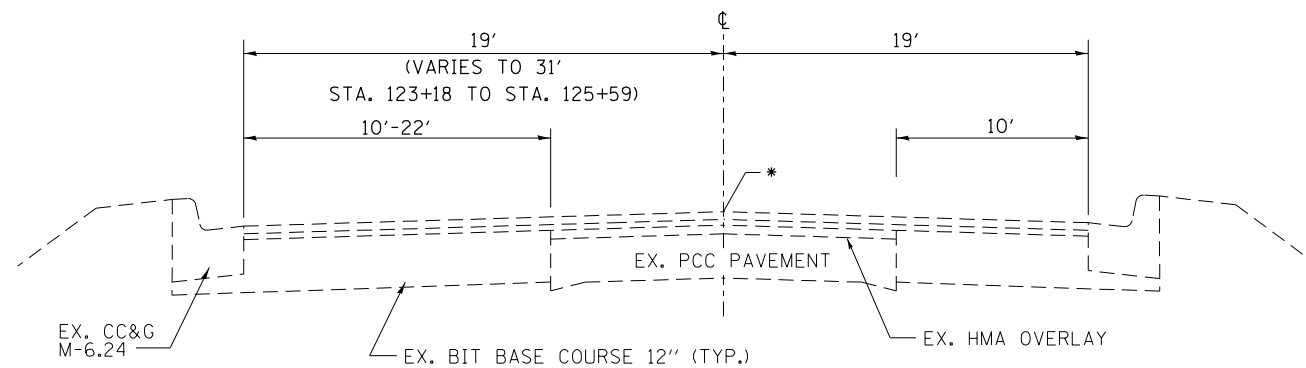

TYPICAL SECTION IL 26

STA. 122+57 TO STA. 136+45.6
STA. 140+81.3 TO STA. 146+07
PROP CRACK SEALING - SEE DETAIL

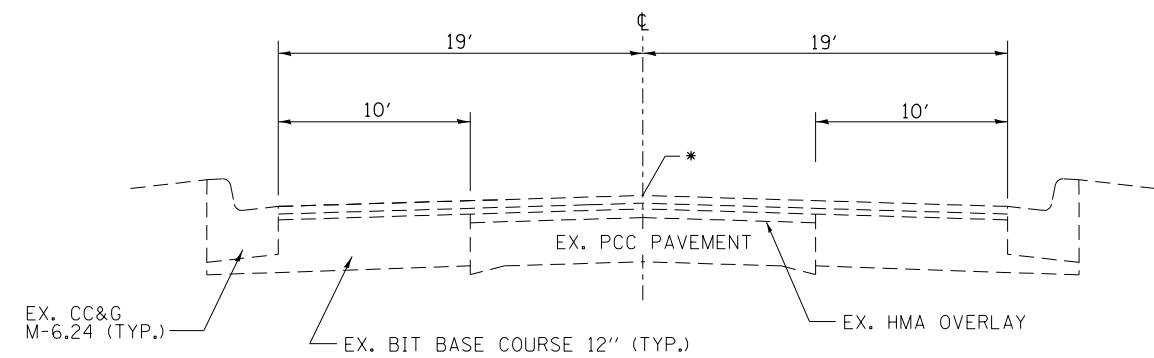

TYPICAL SECTION IL 26

STA. 136+45.6 TO STA. 140+81.3
STA. 146+07 TO STA. 151+05
PROP CRACK SEALING - SEE DETAIL

FILE NAME =	USER NAME = corcoranlm	DESIGNED -	REVISED -	STATE OF ILLINOIS DEPARTMENT OF TRANSPORTATION	TYPICAL SECTION	F.A.P. RTE.	SECTION	COUNTY	TOTAL SHEETS	SHEET NO.	
pw:\planroom\dot\illinois.gov\PWDOT\Documents\IDOT	0:\files\District 3\Projects\D366J87\CADData\D366J87-shd-details.d	DRAWN -	REVISED -			615/646	(116)CJS & (103.104)RS-6	BUREAU	10	5	
Default		CHECKED -	REVISED -			CONTRACT NO. 66J87					
	PLOT DATE = 3/14/2019	DATE -	REVISED -			SCALE:	SHEET	OF	SHEETS	STA.	TO STA.

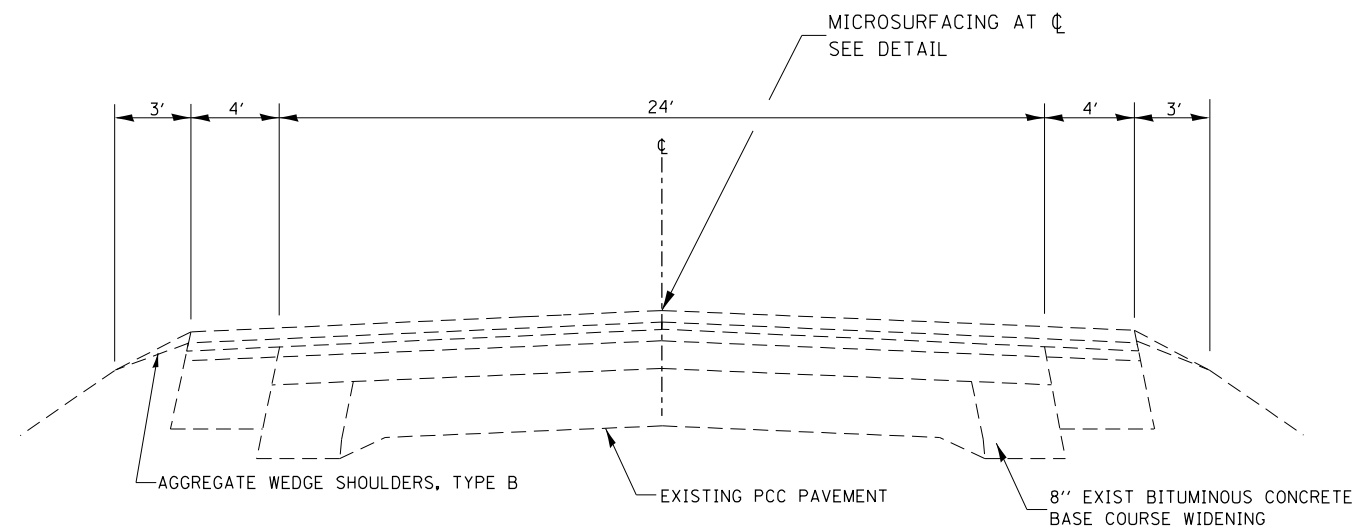

TYPICAL SECTION IL 40

STA 800+83 TO STA 1170+68
STA 1187+89 TO STA 1420+00

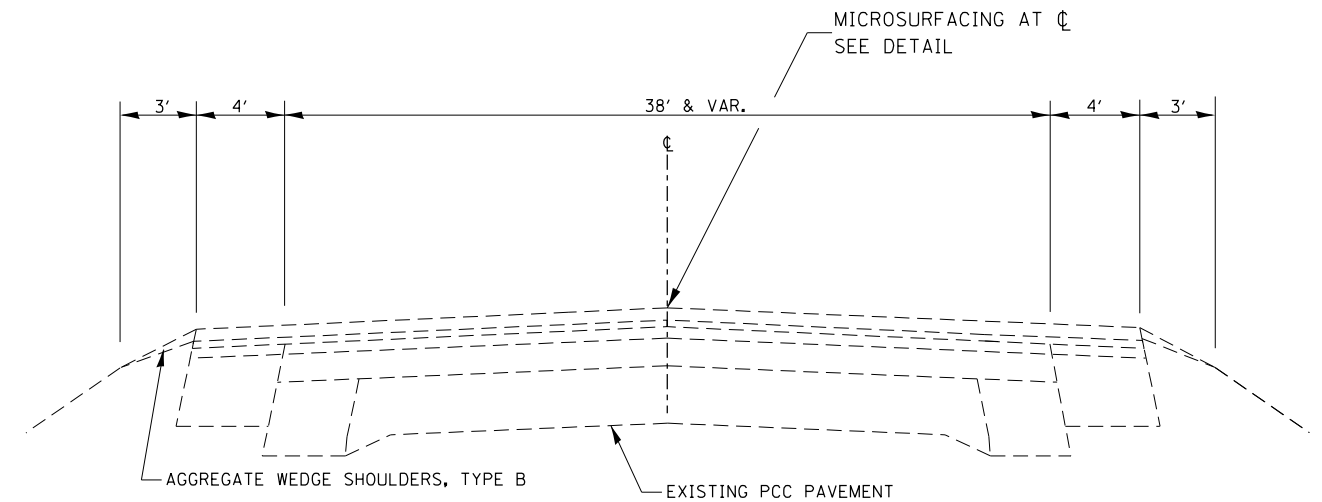

TYPICAL SECTION IL 40

STA 1170+68 TO STA 1179+49

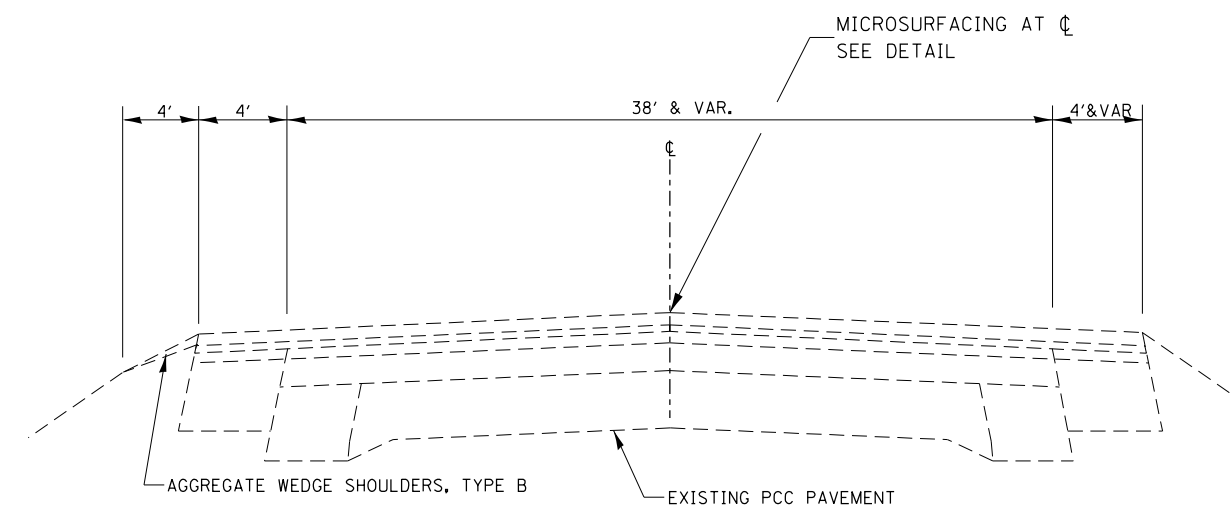

TYPICAL SECTION IL 40

STA 1179+49 TO STA 1182+29
STA 1184+82 TO STA 1187+89

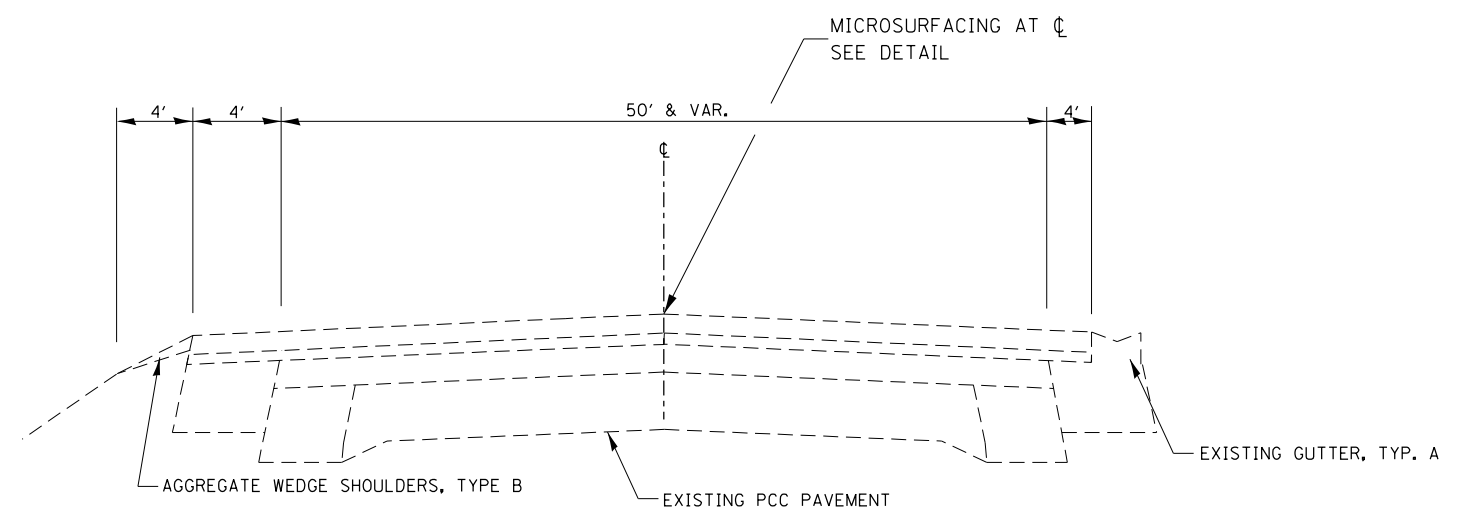

TYPICAL SECTION IL 40

STA 1182+29 TO STA 1184+82

FILE NAME =	USER NAME = corcoranlm	DESIGNED -	REVISED -
p:\planroom\dot\illinois\gov\PWIDOT\Documents\IDOT\Files\District 3\Projects\D366J87\CADData\D366J87-shd-details.dwg		DRAWN -	REVISED -
Default	PLOT SCALE = 100.0000' / in.	CHECKED -	REVISED -
	PLOT DATE = 3/14/2019	DATE -	REVISED -

**STATE OF ILLINOIS
DEPARTMENT OF TRANSPORTATION**

TYPICAL SECTION

SCALE: SHEET OF SHEETS STA. TO STA.

F.A.P. RTE.	SECTION	COUNTY	TOTAL SHEETS	SHEET NO.
615/646	(116)CJS & (103.104)RS-6	BUREAU	10	6
CONTRACT NO. 66J87				
ILLINOIS FED. AID PROJECT				

CRACK ROUTING AND SEALING - IL 26							
LOCATION		LENGTH	LONGITUDINAL CRACK ROUTING (PAVEMENT)	TRANSVERSE CRACK ROUTING (PAVEMENT)	LONGITUDINAL CRACK FILLING	TRANSVERSE CRACK FILLING	REMARKS
STA	STA	FT	FOOT	FOOT	POUND	POUND	
IL 26 (CENTERLINE)							
108+23	151+05	4282	4282	948	1499	332	
IL 26 (SB TURN LANES & MEDIANS)							
108+23	115+34	711	711		249		
119+23	122+57	334	334		117		
126+23	147+53	2130	2130		746		
147+53	149+59	206	206		72		
IL 26 (NB TURN LANES & MEDIANS)							
115+34	119+23	389	389		136		
115+34	118+84	350	350		123		
122+57	127+28	471	471		165		
123+18	126+23	305	305		107		
149+59	151+05	146	146		51		
SUBTOTAL			9324	948	3265	332	
PROJECT TOTAL			10272		3597		

FILE NAME =	USER NAME = corcoranlm	DESIGNED -	REVISED -
pw:\planroom\dot\illinois.gov\PWDOT\Documents\IDOT	Office\District 3\Projects\D366J87\CADData\D366J87-sht-details.dwg	DRAWN -	REVISED -
Default	PLOT SCALE = 100,0000' / in.	CHECKED -	REVISED -
	PLOT DATE = 3/14/2019	DATE -	REVISED -

**STATE OF ILLINOIS
DEPARTMENT OF TRANSPORTATION**

SCHEDULES			
SCALE:	SHEET	OF	SHEETS
	STA.	TO	STA.

F.A.P. RTE.	SECTION	COUNTY	TOTAL SHEETS	SHEET NO.
615/646	(116)CJS & (103,104)RS-6	BUREAU	10	7
CONTRACT NO. 66J87				
ILLINOIS		FED. AID PROJECT		

MICROSURFACING							
LOCATION		LENGTH	WIDTH	MICRO-SURFACING SINGLE PASS MIX D	MIX FOR CRACKS JTS & FLANGEWAYS	FIBER MOD ASPHALT CRACK SEALING	BIT MAT TACK COAT
STA	STA	FOOT	FOOT	SQ YD	FOOT	FOOT	POUND
IL 40 (CENTERLINE)							
922+15	954+04	RURAL	3189	2	709	0.21	159
954+04	955+08		S.N. 006-0086 OMISSION				
955+08	1242+06	RURAL	28698	2	6377	1.91	1435
1242+06	1243+40		S.N. 006-0156 OMISSION				
1243+40	1266+13	RURAL	2273	2	505	0.15	114
1266+16	1267+38		S.N. 006-0157 OMISSION				
1267+38	1420+00	RURAL	15262	2	3392	1.02	763
IL 40 (NB TURN LANES & MEDIANS)							
1181+17	1187+89	RURAL	672	2	149	0.04	34
IL 40 (SB TURN LANES & MEDIANS)							
1170+68	1181+17	RURAL	1049	2	233	0.07	52
SUBTOTAL					11365	3.4	2557

BUMP REMOVAL - IL 40		
LOCATION	NORTH BOUND	SOUTH BOUND
	EACH	EACH
STA	STA	
IL 40 (CENTERLINE)		
922+15	1420+00	10
SUBTOTAL		10
TOTAL		20

PAVEMENT MARKING - IL 40													
LOCATION		LENGTH	POLYUREA PVMT MARKING, TY 1			TEMPORARY PVMT MARKING			PVMT MARK REM WATER BLASTING	SHORT TERM PVMT MARK	SHORT TERM PVMT MARK REM	RAISED REFL PVMT MARK	RAISED REFL PVMT MARK REM
			YELLOW 4"	YELLOW 6"	WHITE 8"	YELLOW 4"	YELLOW 6"	WHITE 8"					
STA	STA	FOOT	FOOT	FOOT	FOOT	FOOT	FOOT	FOOT	SQ FT	FOOT	SQ FT	EACH	EACH
IL 40 (CENTERLINE)													
922+15	1420+00	RURAL	49785	24892			12446		18669	4979	1660	623	623
IL 40 (NO PASSING ZONES) THROUGHOUT PROJECT													
			30852			15426		15426					
IL 40 (TURN LANES & MEDIANS)													
1181+17	1187+89	RURAL	1509	3018	1054	1509	527	2212					
SUBTOTAL			33870	24892	1054	16935	12446	527	36307	4979	1660	623	623

- NOTES:
- PAVEMENT MARKINGS SHALL NOT BE APPLIED TO IL 26
 - ONLY CENTERLINE, MEDIAN LINES, AND LANE LINES DISTURBED BY MICROSURFACING OPERATIONS SHALL BE REPLACED
 - QUANTITY HAS BEEN INCLUDED FOR TWO SEPARATE APPLICATIONS OF POLYUREA PAVEMENT MARKING, TYPE 1
 - EXISTING PAVEMENT MARKING SHALL BE REMOVED PRIOR TO MICRO-SURFACING OPERATIONS AT THAT JOINT

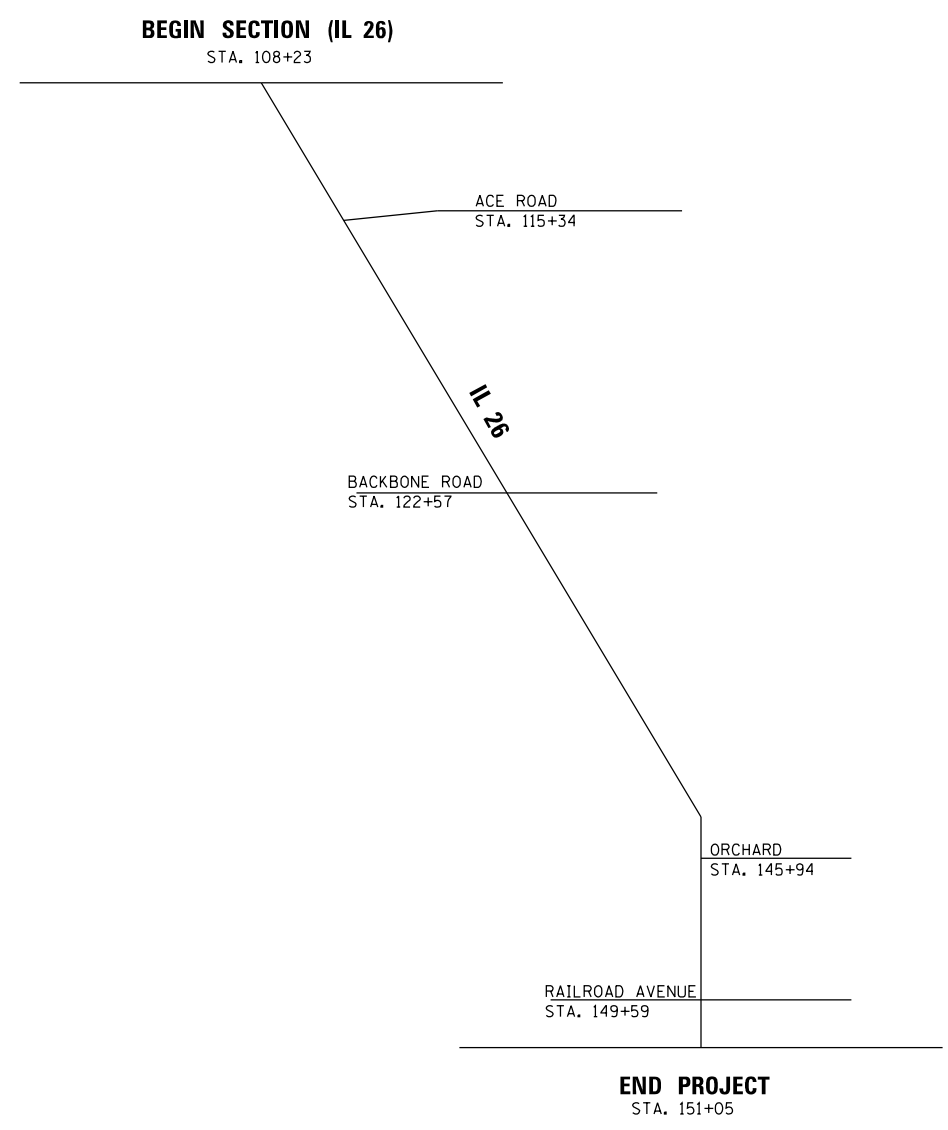
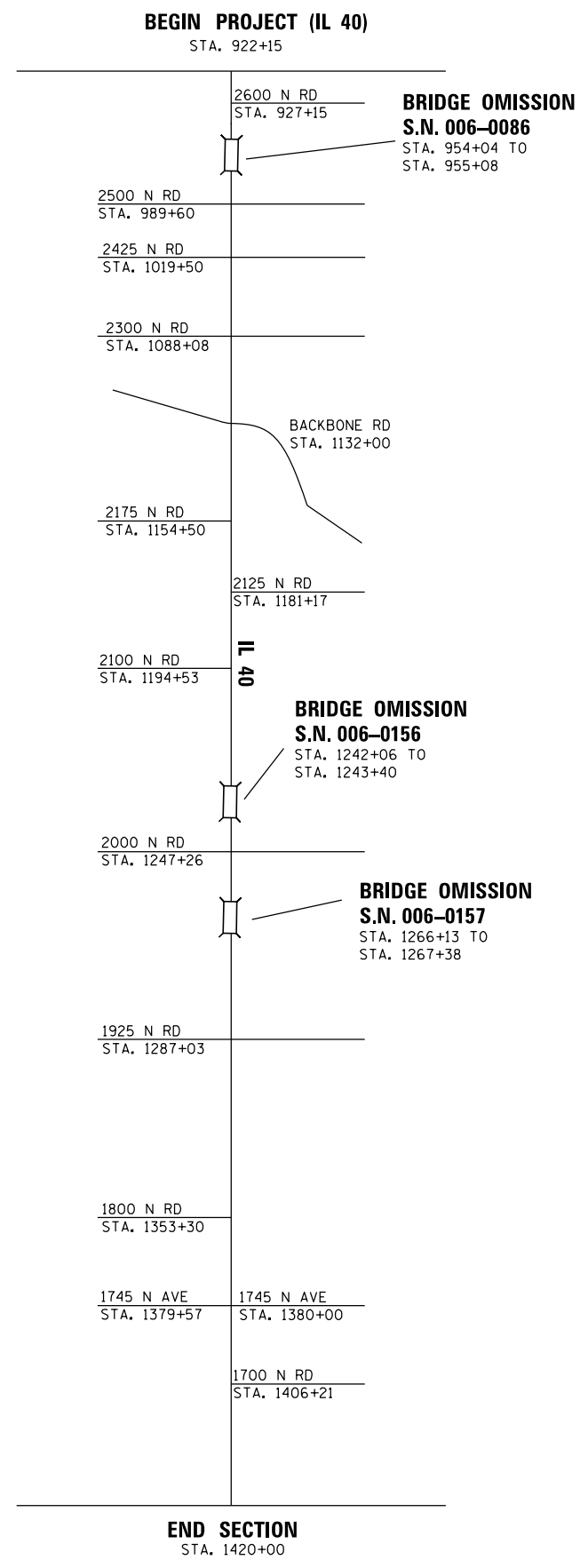

GPS NUMBER	DESCRIPTION	EXISTING MONUMENT TYPE	PROPOSED MONUMENT TYPE	MONUMENT RECORD TO BE RECORDED	RESPONSIBILITY
N/A	NO PERMANENT SURVEY MARKERS OR SECTION CORNER MARKERS TO BE SET ON THIS JOB	N/A	N/A	N/A	N/A

NO KNOWN SURVEY OR CENTERLINE CONTROL MONUMENTS ARE IN A LOCATION THAT WILL BE DISTURBED BY THE CRACK AND JOINT SEALING OR MICROSURFACING WORK. IF A MONUMENT IS LOCATED THAT WILL BE REMOVED DUE TO THIS WORK, THE R.E. WILL INFORM THE PLATS AND PLANS SECTION OF THE LOCATION, AND THE PLATS AND PLANS SECTION WILL SET AND TIE A SUITABLE REPLACEMENT MONUMENT AFTER WORK IS COMPLETED. NO MONUMENT RECORDS ARE ANTICIPATED FOR THIS JOB.

FILE NAME =	USER NAME = corcoranlm	DESIGNED -	REVISED -
pw:\planroom\dot\illinois.gov\PWIDOT\Documents\IDOT\Offices\District 3\Projects\D366J87\CADData\D366J87-shd-details.dwg		DRAWN -	REVISED -
Default	PLOT SCALE = 100,0000' / in.	CHECKED -	REVISED -
	PLOT DATE = 3/14/2019	DATE -	REVISED -

**STATE OF ILLINOIS
DEPARTMENT OF TRANSPORTATION**

LAYOUT MAP

SCALE: SHEET OF SHEETS STA. TO STA.

F.A.P. RTE.	SECTION	COUNTY	TOTAL SHEETS	SHEET NO.
645/646	(116)CJS & (103,104)RS-4	BUREAU	10	9
CONTRACT NO. 66J87				
ILLINOIS		FED. AID PROJECT		

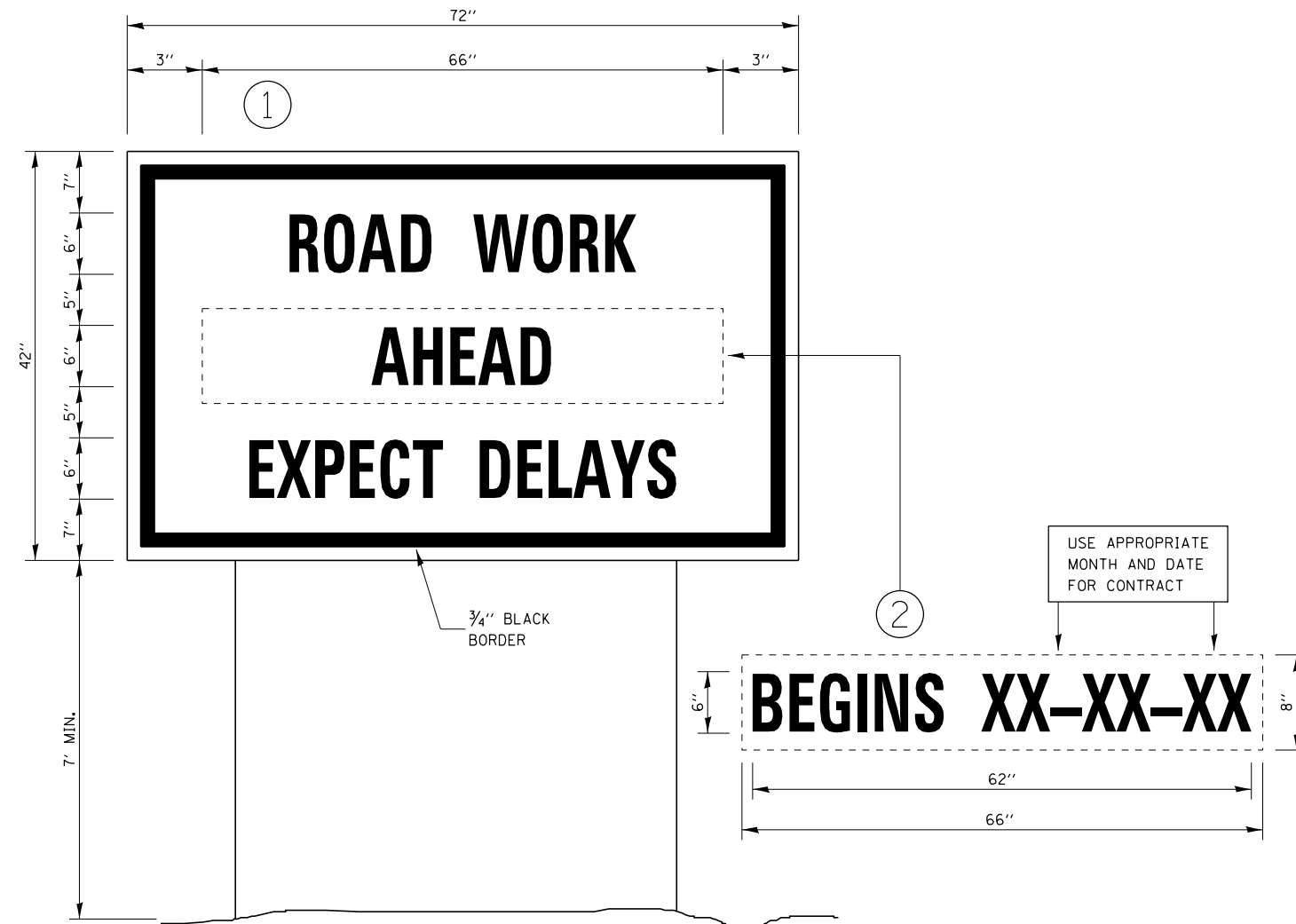

TEMPORARY INFORMATION SIGNING

NOTES:

1. USE 6" D BLACK LETTERING ON FLUORESCENT ORANGE BACKGROUND.
2. ERECT SIGNS AT LOCATIONS IN ADVANCE OF THE "ROAD CONSTRUCTION AHEAD" SIGNS AS DIRECTED BY THE ENGINEER.
3. ERECT SIGN ① WITH INSTALLED PANEL ② A MINIMUM OF ONE WEEK PRIOR TO THE START OF THE LANE CLOSURE.
4. REMOVE PANEL ② ON THAT DATE.
5. SEE SPECIAL PROVISION "TEMPORARY INFORMATION SIGNING" FOR ADDITIONAL INFORMATION.
6. WILL BE PAID FOR PER SQ FT AS "TEMPORARY INFORMATION SIGNING". EACH SIGN = 21 SQ FT AND THE DATE PANEL ② WILL NOT BE MEASURED SEPARATELY FOR PAYMENT.

CRACK SEALING HMA PAVEMENT

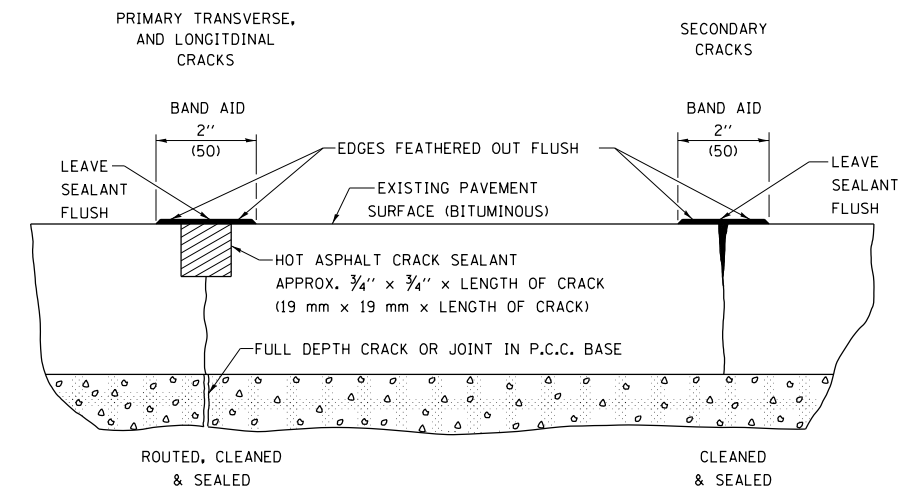

IL - 26

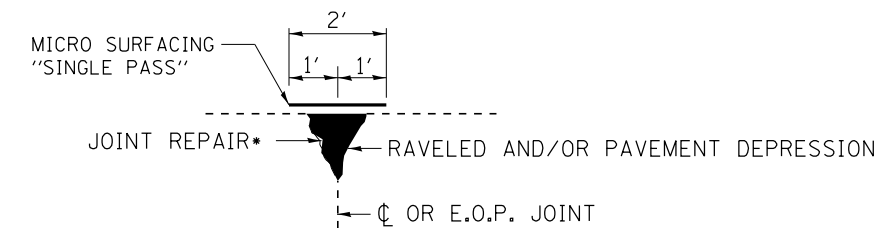

MICRO-SURFACING DETAIL

- FIBER-MODIFIED ASPHALT CRACK SEALING

NOTES

- 1) MICRO-SURFACING SHALL BE LOCATED AT THE CENTERLINE OF PAVEMENT JOINT. ACTUAL LOCATIONS SHALL BE FIELD DETERMINED BY THE ENGINEER PRIOR TO THE CONTRACTOR BEGINNING HIS/HER CONSTRUCTION OPERATIONS.
- 2) THE TEMPORARY STRIPING SHALL BE OFFSET FROM THE CENTERLINE, AS DIRECTED BY THE ENGINEER.
- 3) OFFSET OF THE PERMANENT CENTERLINE PAVEMENT STRIPING SHALL BE FIELD DETERMINED BY THE ENGINEER.

IL - 40

FILE NAME =	USER NAME = corcoranlm	DESIGNED -	REVISED -	STATE OF ILLINOIS DEPARTMENT OF TRANSPORTATION	DETAILS			F.A.P. RTE.	SECTION	COUNTY	TOTAL SHEETS	SHEET NO.
pw:\planroom\dot\illinois\gov\PWIDOT\Documents\IDOT\Projects\District 3\Projects\D366J87\CADData\D366J87-shd-details.dwg	DRAWN -	REVISED -	REVISED -		615/646	(116)CJS & (103,104)RS-6	BUREAU	10	10			
Default	PLOT SCALE = 100,0000' / in.	CHECKED -	REVISED -		CONTRACT NO. 66J87							
	PLOT DATE = 3/14/2019	DATE -	REVISED -		SCALE:	SHEET OF SHEETS	STA.	TO STA.	ILLINOIS FED. AID PROJECT			