

FOR INDEX OF SHEETS, SEE SHEET NO. 2
FOR SUMMARY OF QUANTITIES, SEE SHEETS NO. 4-9

STATE OF ILLINOIS
DEPARTMENT OF TRANSPORTATION

F.A.P. RATE	SECTION	COUNTY	TOTAL SHEETS	SHEET NO.
836	**	ILLINOIS	214	1
**118RS-3,119RS-4,D5 HSIP 2019-1			*CHAMPAIGN & VERMILION	

PROPOSED HIGHWAY PLANS

FAP ROUTE 836 (IL-49)
SECTION 118RS-3,119RS-4,D5 HSIP 2019-1
PROJECT STP-HSIP-R444(878)
RESURFACING (SMART) NEW SHOULDERS
MILLED RUMBLE STRIPS
BRIDGE DECK OVERLAY
CULVERT REPLACEMENT
CHAMPAIGN & VERMILION COUNTY



OMISSIONS FROM PAVING
S.N. 010-0236 (E-E HATCH BLOCKS)
S.N. 010-0284 (E-E OF APPROACH SLABS)

HMA 2" INLAY AND WATERPROOFING MEMBRANE
S.N. 010-0269

HMA 1 1/2" INLAY
S.N. 010-8104
S.N. 010-8170
S.N. 010-8171
S.N. 010-8348
S.N. 092-8616

CULVERT REPLACEMENT 10' x 4'
S.N. 010-8178
S.N. 010-8177

TRAFFIC DATA

	LEG "A"	LEG "B"
2018 ADT	= 1,500	1,050
PV%	= 81.4%	76.2%
SU%	= 5.3%	11.4%
MU%	= 13.3%	12.4%

TRAFFIC DATA LOCATIONS

LEG "A" = FAP 836 FROM MADISON ST. IN HOMER TO CH 49 IN ALLERTON
LEG "B" = FAP 836 FROM CH 49 IN ALLERTON TO 100N/200N

TOWNSHIP:
AYERS AND SOUTH HOMER

BEGIN SECTION
(118RS-3,119RS-4,D5 HSIP 2019-1)
STA. 321+00.00

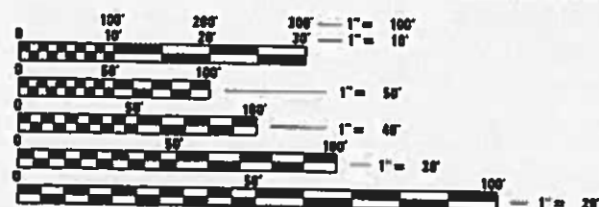

FULL SIZE PLANS HAVE BEEN PREPARED USING STANDARD ENGINEERING SCALES. REDUCED SIZED PLANS WILL NOT CONFORM TO STANDARD SCALES. IN MAKING MEASUREMENTS ON REDUCED PLANS, THE ABOVE SCALES MAY BE USED.

J.U.L.I.E.
JOINT UTILITY LOCATION INFORMATION FOR EXCAVATION
1-800-892-0123
OR 811

PROJECT ENGINEER: JASON W. STULTS
SQUAD LEADER: RYAN T. CARROLL
DESIGNER: TYLER J. PIERSON
PHONE: (217)-465-4181
CONTRACT NO. 70D56

CULVERT REPLACEMENT

STA. 691+21.33 AT CR 600N
PR S.N. 010-8176

C-95-015-19

HOMER SCL TO VERMILION/EDGAR CO. LINE

CULVERT REPLACEMENT

STA. 701+63.97 AT FE
PR S.N. 010-8177

S.N. 010-0269

STA. 729+30.49 TO STA. 729+66.49

WATERPROOFING MEMBRANE & RESURFACING

FUNCTIONAL CLASSIFICATION:
MINOR ARTERIAL

END SECTION

(118RS-3,119RS-4,D5 HSIP 2019-1)
STA. 903+82.91

S.N. 010-8348
STA. 601+34.64
1 1/2" INLAY

S.N. 092-8616
STA. 380+80.28
1 1/2" INLAY

S.N. 010-8104
STA. 491+37.19
1 1/2" INLAY

S.N. 010-0236
STA. 663+12.95 TO STA. 665+78.19
OMISSION

S.N. 010-8170
STA. 752+79.73
1 1/2" INLAY

S.N. 010-0284
STA. 686+26.44 TO STA. 690+77.80
OMISSION

GROSS LENGTH = 58,282.91 FT. = 11.0 MILE
NET LENGTH = 57,566.31 FT. = 10.9 MILE

STATE OF ILLINOIS
DEPARTMENT OF TRANSPORTATION

SUBMITTED 03/22 20 19
Kenneth A. Darnett
REGIONAL ENGINEER

May 10 2019
EA. ETK
ENGINEER OF DESIGN AND ENVIRONMENT

May 10 2019
Paul P. Chy
DIRECTOR OF HIGHWAYS PROJECT IMPLEMENTATION

PRINTED BY THE AUTHORITY OF THE STATE OF ILLINOIS

INDEX OF SHEETS

DESCRIPTION	SHEET NO.
COVER SHEET	1
INDEX OF SHEETS & LIST OF HIGHWAY STANDARDS & COMMITMENTS	2
GENERAL NOTES	3
SUMMARY OF QUANTITIES	4 to 9
TYPICAL CROSS SECTIONS	10 to 16
SCHEDULE OF QUANTITIES	17 to 35
CONTROL POINTS	36
PLAN SHEETS	37 to 57
CR 600N PLAN SHEET	58
FIELD ENTRANCE PLAN SHEET	59
GENERAL PLAN & STRUCTURE DETAIL S.N. 010-0269	60
TYPICAL STAGING CONTRUCTION DETAIL S.N. 010-0269	61
WATERPROOFING MEMBRANE DETAIL S.N. 010-0269	62
AS-BUILT PLANS S.N. 010-0269	63 to 65
GENERAL PLAN & ELEVATION CR 600N CULVERT	66
GENERAL PLAN & ELEVATION FIELD ENTRANCE CULVERT	67
SINGLE CELL PRECAST BOX CULVERT TAPERED END SECTIONS DETAIL	68 to 69
TRAVERSABLE PIPE GRATE FOR BOX CULVERTS	70
TYPICAL ENTRANCE DETAIL	71
HEADWALL MODIFICATION DETAIL	72
WIDTH RESTRICTION DETAIL	73 to 74
TRAFFIC BARRIER TERMINAL TYPE 6A (MODIFIED) MOUNTING DETAILS	75
EARTHWORK CALCULATION DETAIL	76
DISTRICT 5 DETAILS	77 to 91
IL-49 CROSS-SECTIONS	92 to 211
CR 600N CROSS-SECTIONS	212 to 213
FIELD ENTRANCE CROSS-SECTIONS	214

LIST OF STANDARDS

STANDARD NO.	DESCRIPTION
000001-07	STANDARD SYMBOLS, ABBREVIATIONS AND PATTERNS
001001-02	AREAS OF REINFORCEMENT BARS
001006	DECIMAL OF AN INCH AND OF A FOOT
280001-07	TEMPORARY EROSION CONTROL SYSTEMS
442201-03	CLASS C AND D PATCHES
482011-03	HMA SHOULDER STRIPS/SHOULDERS WITH RESURFACING OR WIDENING AND RESURFACING PROJECTS
630001-12	STEEL PLATE BEAM GUARDRAIL
630106-02	LONG-SPAN GUARDRAIL OVER CULVERT
630301-09	SHOULDER WIDENING FOR TYPE 1 (SPECIAL) GUARDRAIL TERMINALS
631011-10	TRAFFIC BARRIER TERMINAL, TYPE 2
631031-15	TRAFFIC BARRIER TERMINAL, TYPE 6
631032-09	TRAFFIC BARRIER TERMINAL, TYPE 6A
642006	SHOULDER RUMBLE STRIPS, 8 IN.
701001-02	OFF-RD OPERATIONS, 2L, 2W MORE THAN 15' (4.5M) AWAY
701006-05	OFF-RD OPERATIONS, 2L, 2W, 15' (4.5 M) TO 24" (600 MM) FROM PAVEMENT EDGE
701011-04	OFF-RD MOVING OPERATIONS, 2L, 2W, DAY ONLY
701201-05	LANE CLOSURE, 2L, 2W, DAY ONLY, FOR SPEEDS ≥ 45 MPH
701301-04	LANE CLOSURE, 2L, 2W, SHORT TIME OPERATIONS
701306-04	LANE CLOSURE, 2L, 2W, SLOW MOVING OPERATIONS DAY ONLY, FOR SPEEDS ≥ 45 MPH
701311-03	LANE CLOSURE 2L, 2W MOVING OPERATIONS-DAY ONLY
701316-12	LANE CLOSURE, 2L, 2W, BRIDGE REPAIRE FOR SPEEDS ≥ 45 MPH
701336-07	LANE CLOSURE, 2L, 2W, WORK AREAS IN SERIES FOR SPEEDS ≥ 45 MPH
701901-08	TRAFFIC CONTROL DEVICES
725001-01	OBJECT AND TERMINAL MARKERS
780001-05	TYPICAL PAVEMENT MARKINGS
781001-04	TYPICAL APPLICATIONS RAISED REFLECTIVE PAVEMENT MARKERS
782006	GUARDRAIL AND BARRIER WALL REFLECTOR MOUNTING DETAILS

COMMITMENTS

THERE ARE NO COMMITMENTS FOR THIS CONTRACT.

MODEL: I:\MODEL\NAME: FILE: NAME: P:\pub\mcom\ma.d\illinois\pwr\WIDOT\Documents\DOT_Offices\District 5\Projects\0570D56\CADD\Design\0570D56-eh-Index of Sheets & List of Standards & Commitment.dgn

USER NAME = PiersonTJ	DESIGNED -	REVISED -
	DRAWN -	REVISED -
PLOT SCALE = 40,0000 ' / in.	CHECKED -	REVISED -
PLOT DATE = 3/22/2019	DATE -	REVISED -

STATE OF ILLINOIS
DEPARTMENT OF TRANSPORTATION

INDEX OF SHEETS & LIST OF STANDARDS
& COMMITMENTS

SCALE: SHEET 1 OF 1 SHEETS STA. TO STA.

F.A.P. RTE.	SECTION	COUNTY	TOTAL SHEETS	SHEET NO.
836	**	-	214	2
			CONTRACT NO. 70D56	

**118RS-3,119RS-4,D5 HSIP 2019-1

*CHAMPAIGN & VERMILION

GENERAL NOTES

G.N. – 100B
MICROSTATION AND GEOPAK FILES OF THIS PROJECT WILL BE MADE AVAILABLE TO THE CONTRACTOR AFTER CONTRACT AWARD. IF THERE IS A CONFLICT BETWEEN THE ELECTRONIC FILES AND THE PRINTED CONTRACT PLANS AND DOCUMENTS, THE PRINTED CONTRACT PLANS AND DOCUMENTS SHALL TAKE PRECEDENCE OVER THE ELECTRONIC FILES. THE CONTRACTOR SHALL ACCEPT ALL RISK ASSOCIATED WITH USING THE ELECTRONIC FILES AND SHALL HOLD THE DEPARTMENT HARMLESS FOR ANY ERRORS OR OMISSIONS IN THE ELECTRONIC FILES AND THE DATA CONTAINED THEREIN. ERRORS OR DELAYS RESULTING FROM THE USE OF THE ELECTRONIC FILES BY THE CONTRACTOR SHALL NOT RESULT IN AN EXTENSION OF TIME FOR ANY INTERIM OR FINAL COMPLETION DATE OR SHALL NOT BE CONSIDERED CAUSE FOR ADDITIONAL COMPENSATION. THE CONTRACTOR SHALL NOT USE, SHARE, OR DISTRIBUTE THESE ELECTRONIC FILES EXCEPT FOR THE PURPOSE OF CONSTRUCTING THIS CONTRACT. ANY CLAIMS BY THIRD PARTIES DUE TO USE OR ERRORS SHALL BE THE SOLE RESPONSIBILITY OF THE CONTRACTOR. THE CONTRACTOR SHALL INCLUDE THIS DISCLAIMER WITH THE TRANSFER OF THESE ELECTRONIC FILES TO ANY OTHER PARTIES AND SHALL INCLUDE APPROPRIATE LANGUAGE BINDING THEM TO SIMILAR RESPONSIBILITIES.

G.N.-105.09A
ALL ELEVATIONS SHOWN IN THE PLANS ARE BASED ON NORTH AMERICAN VERTICAL DATUM OF 1988. (NAVD 88)

G.N.-250C
SEEDING, CLASS 7 AND MULCH, METHOD 2 IS INCLUDED IN THIS CONTRACT TO SEED NEW EARTH SHOULDERS DURING TIME PERIODS WHEN PERMANENT SEEDING IS NOT ALLOWED. SOME OR ALL OF THE CLASS 7 SEEDING AND MULCH WILL BE DELETED IF IT IS POSSIBLE TO PLACE PERMANENT SEEDING ON EARTH SHOULDERS AT THE TIME OF THEIR COMPLETION.

THE QUANTITIES INCLUDED IN THE PLANS FOR HOT-MIX ASPHALT RESURFACING ARE INTENDED TO GIVE THE COVERAGE SHOWN ON THE TYPICAL CROSS SECTIONS. IT IS NOT INTENDED TO INCREASE THE THICKNESS OF THE HOT-MIX ASPHALT MIXTURE IN ORDER TO USE ALL OF THE QUANTITIES INCLUDED IN THE CONTRACT.

G.N. -406H

MIXTURE REQUIREMENTS

THE FOLLOWING MIXTURE REQUIREMENTS ARE APPLICABLE FOR THIS PROJECT:

Location	IL 49	IL 49	IL 49	IL 49
Mixture Use	Surface & Top 1/2" Shoulders*	Incidental	Patching	Bottom Shoulder
AC/PG	PG 64-22	PG 64-22	PG 64-22	PG 64-22
Design Air Voids	4.0% @ Ndes=50	4.0% @ Ndes=50	4.0% @ Ndes=50	4.0% @ Ndes=50
Mix Comp(Gradation)	IL 9.5	IL 9.5	IL 19.0	IL 19.0
Friction Aggregate	Mix C	Mix C	N.A.	N.A.
Mixture Weight	112	112	112	112
Quality Management Program	QCP	QC/QA	QC/QA	QC/QA
Sublot Size	1000	N.A.	N.A.	N.A.

*Top lift of shoulder to be placed concurrently with mainline surface lift.

G.N.-408B
THE INCIDENTAL HOT-MIX ASPHALT SURFACING SHALL BE COMPACTED AS REQUIRED BY THE SPECIFICATIONS FOR DESIGN NUMBER OF GYRATIONS BEING USED,

AT THE FOLLOWING LOCATIONS:

CR 600N
CR 2800E
BROADLANDS RD.

G.N.-440C
THE MACHINE USED FOR HOT-MIX ASPHALT SURFACE REMOVAL ON THE THROUGH TRAFFIC LANES ON THIS JOB SHALL BE CAPABLE OF REMOVING A LAYER OF BITUMINOUS MATERIAL AT LEAST 12 FT. IN WIDTH AND 1 1/2 INCHES IN DEPTH IN A SINGLE PASS.

G.N.- 442B - PATCHING SCHEDULES
THE PATCHING SCHEDULES INCLUDED IN THE PLANS REPRESENT THE BEST INFORMATION AVAILABLE AT THE TIME OF COMPLETION OF THE PLANS FOR LETTING. VARIATIONS IN LOCATION AND SIZES OF THE FULL-DEPTH AND PARTIAL-DEPTH PATCHES MAY OCCUR.

G.N.- 540
THE CONTRACTOR SHALL ASSEMBLE AND MATCH-MARK THE PRECAST BOX CULVERT SECTIONS AND END SECTIONS PRIOR TO SHIPMENT OF THESE COMPONENTS FROM THE MANUFACTURER, AND AS DIRECTED BY THE ENGINEER IN ORDER TO SECURE A PROPER FIT ON EACH JOINT. ANY SECTIONS OR END SECTIONS WHICH DO NOT PROVIDE A PROPER FIT AT THE JOINT SHALL BE REJECTED BY THE ENGINEER AND REPLACED BY THE CONTRACTOR WITH NO ADDITIONAL COMPENSATION BEING ALLOWED.

THIS WORK WILL NOT BE PAID FOR SEPARATELY, BUT SHALL BE INCLUDED IN THE CONTRACT UNIT PRICE PER FOOT FOR PRECAST CONCRETE BOX CULVERTS OF THE SIZE SPECIFIED.

G.N.- 667
THE RESIDENT ENGINEER SHALL CONTACT THE PROGRAM DEVELOPMENT CHIEF OF SURVEYS PRIOR TO THE PRE-CONSTRUCTION CONFERENCE FOR INSTRUCTION AS TO SETTING OF TEMPORARY OR PERMANENT TIES FOR CENTERLINE ALIGNMENT CONTROL SURVEY MARKERS (PC'S, PT'S, AND PI'S). PROJECT IMPLEMENTATION PERSONNEL WILL BE RESPONSIBLE FOR LAYOUT OF THESE MARKERS.

G.N.- 703A
SHORT TERM PAVEMENT MARKING SHALL BE APPLIED TO THE PAVEMENT AFTER ANY OF THE FOLLOWING: COLD MILLING AND/OR PLACING BITUMINOUS MATERIALS (TACK COAT), LEVELING BINDER (MACHINE METHOD), BINDER AND SURFACE COURSES. SHORT TERM PAVEMENT MARKING PLACED ON THE SURFACE SHALL COINCIDE WITH THE FINAL PAVEMENT STRIPING. SHORT TERM PAVEMENT MARKING PLACED PRIOR TO THE SURFACE SHALL COINCIDE WITH THE EXISTING PAVEMENT MARKINGS. USE 4 FEET PER 40 FEET (OR 10% PER STATION).

G.N.- 781
THE FINAL PAVEMENT MARKINGS SHALL BE IN PLACE PRIOR TO PLACING THE RAISED REFLECTIVE PAVEMENT MARKERS.

G.N.- 1004.01
COARSE AGGREGATE GRADATION CA-10 MAY BE USED WHENEVER COARSE AGGREGATE CA-6 IS SPECIFIED IN THE STANDARD SPECIFICATIONS.

MODEL: \\MODEL\MHETS
FILE: \\MAILS_PUB\pub\homedata\illinois.gov\RWIDOT\Documents\DOT_Offices\District_5\Projects\0570D556\CaddData\Design\0570D556-01-Genral_Notes.dgn

USER NAME = PiersonTJ	DESIGNED -	REVISED -
DRAWN -	REVISIED -	
PLOT SCALE = 40.0000 ' / in.	CHECKED -	REVISED -
PLOT DATE = 3/22/2019	DATE -	REVISED -

**STATE OF ILLINOIS
DEPARTMENT OF TRANSPORTATION**

GENERAL NOTES

SCALE: SHEET 1 OF 1 SHEETS STA. TO STA.

F.A.P. RTE.	SECTION	COUNTY	TOTAL SHEETS	SHEET NO.
836	**	-	214	3
				CONTRACT NO. 70D56

**118RS-3,119RS-4,D5 HSIP 2019-1

*CHAMPAIGN & VERMILION

SUMMARY OF QUANTITIES

LOCATION OF WORK:	SMART			HSIP	
	FAP 836 IL-49 RURAL STA. 421+77.05 STA. 903+82.91 CHAMPAIGN CO	FAP 836 IL-49 RURAL STA.321+00.00 STA. 421+77.05 VERMILION CO	FAP 836 IL-49 RURAL STA. 421+77.05 STA. 903+82.91 CHAMPAIGN CO	FAP 836 IL-49 RURAL STA. 421+77.05 STA. 903+82.91 CHAMPAIGN CO	FAP 836 IL-49 RURAL STA.321+00.00 STA. 421+77.05 VERMILION CO
FUNDING BREAKOUT:	80% FED / 20% STATE	80% FED / 20% STATE	80% FED / 20% STATE	90% FED / 10% STATE	90% FED / 10% STATE
CONSTRUCTION TYPE CODE:	0005	0005	0059	0021	0021

CODE NO.	ITEM	UNIT	TOTAL QUANTITY	ROADWAY QUANTITY	ROADWAY QUANTITY	S.N. 010-0269 QUANTITY	SHOULDER QUANTITY	SHOULDER QUANTITY
20200100	EARTH EXCAVATION	CU YD	8,770.00				7,335.00	1,435.00
20400800	FURNISHED EXCAVATION	CU YD	840.00				840.00	
20700220	POROUS GRANULAR EMBANKMENT	CU YD	443.00				443.00	
21301052	EXPLORATION TRENCH 52" DEPTH	FOOT	180.00				180.00	
21400100	GRADING AND SHAPING DITCHES	FOOT	447.00				447.00	
25000210	SEEDING, CLASS 2A	ACRE	27.00				23.75	3.25
25000400	NITROGEN FERTILIZER NUTRIENT	POUND	2,430.00				2,137.50	292.50
25000500	PHOSPHORUS FERTILIZER NUTRIENT	POUND	2,430.00				2,137.50	292.50
25000600	POTASSIUM FERTILIZER NUTRIENT	POUND	2,430.00				2,137.50	292.50
25100115	MULCH, METHOD 2	ACRE	27.00				23.75	3.25
28000250	TEMPORARY EROSION CONTROL SEEDING	POUND	10,800.00				9,500.00	1,300.00
28000305	TEMPORARY DITCH CHECKS	FOOT	228.00				212.00	16.00
28000400	PERIMETER EROSION BARRIER	FOOT	237.00				237.00	
35100300	AGGREGATE BASE COURSE, TYPE A 4"	SQ YD	378.00				378.00	
40200800	AGGREGATE SURFACE COURSE, TYPE B	TON	31.00				31.00	
* DENOTES SPECIALTY ITEM								

MODEL: I:\MODEL\MHFS
FILE: MHFS_Plan\118RS-3,119RS-4,05 HSIP\DOT Documents\DOT Office\118RS-3,119RS-4,05 HSIP\118RS-3,119RS-4,05 HSIP.dgn

USER NAME = PiersonTJ	DESIGNED -	REVISED -
	DRAWN -	REVISED -
PLOT SCALE = 40.0000 ' / in.	CHECKED -	REVISED -
PLOT DATE = 3/22/2019	DATE -	REVISED -

**STATE OF ILLINOIS
DEPARTMENT OF TRANSPORTATION**

SUMMARY OF QUANTITIES

SCALE: SHEET 1 OF 6 SHEETS STA. TO STA.

F.A.P. RTE.	SECTION	COUNTY	TOTAL SHEETS	SHEET NO.
836	**	-	214	4
CONTRACT NO. 70D56				

SUMMARY OF QUANTITIES

LOCATION OF WORK:	SMART			HSIP	
	FAP 836 IL-49 RURAL STA. 421+77.05 STA. 903+82.91 CHAMPAIGN CO	FAP 836 IL-49 RURAL STA. 321+00.00 STA. 421+77.05 VERMILION CO	FAP 836 IL-49 RURAL STA. 421+77.05 STA. 903+82.91 CHAMPAIGN CO	FAP 836 IL-49 RURAL STA. 421+77.05 STA. 903+82.91 CHAMPAIGN CO	FAP 836 IL-49 RURAL STA. 321+00.00 STA. 421+77.05 VERMILION CO
FUNDING BREAKOUT:	80% FED / 20% STATE	80% FED / 20% STATE	80% FED / 20% STATE	90% FED / 10% STATE	90% FED / 10% STATE
CONSTRUCTION TYPE CODE:	0005	0005	0054	0021	0021

CODE NO.	ITEM	UNIT	TOTAL QUANTITY	ROADWAY QUANTITY	ROADWAY QUANTITY	S.N. 010-0269 QUANTITY	SHOULDER QUANTITY	SHOULDER QUANTITY
40600290	BITUMINOUS MATERIALS (TACK COAT)	POUND	84,376.00	62,272.00	13,101.00	54.00	7,392.00	1,557.00
40603310	HOT-MIX ASPHALT SURFACE COURSE, MIX "C", N50	TON	17,424.00	11,625.00	2,446.00	11.00	2,760.00	582.00
40800029	BITUMINOUS MATERIALS (TACK COAT)	POUND	903.00	538.00	18.00		195.00	152.00
40800050	INCIDENTAL HOT-MIX ASPHALT SURFACING	TON	255.00	101.00	4.00		121.00	29.00
44000100	PAVEMENT REMOVAL	SQ YD	721.00	124.00			473.00	124.00
44000155	HOT-MIX ASPHALT SURFACE REMOVAL, 1 1/2"	SQ YD	169,243.00	138,382.00	29,112.00		1,083.00	666.00
44004250	PAVED SHOULDER REMOVAL	SQ YD	39.00				39.00	
44201777	CLASS D PATCHES, TYPE II, 11 INCH	SQ YD	29.00		29.00			
44201839	CLASS D PATCHES, TYPE II, 16 INCH	SQ YD	573.00	462.00	111.00			
44201843	CLASS D PATCHES, TYPE III, 16 INCH	SQ YD	40.00	40.00				
44201845	CLASS D PATCHES, TYPE IV, 16 INCH	SQ YD	362.00	362.00				
48101200	AGGREGATE SHOULDERS, TYPE B	TON	16.0				16.0	
48102100	AGGREGATE WEDGE SHOULDER, TYPE B	TON	58.00				50.00	8.00
48203023	HOT-MIX ASPHALT SHOULDERS, 6.5"	SQ YD	38,027.00				31,771.00	6,256.00
* DENOTES SPECIALTY ITEM								

MODEL: \\MODELNAME\$
 FILE: \\NAME\$.prt
 \\servername\dtd\illinois.gov\pwr\DOT\Documents\DOT_Offices\District_3\Projects\0570D56\CADD\Design\0570D56-sh-SQ.dgn

USER NAME = PiersonTJ	DESIGNED -	REVISED -
	DRAWN -	REVISED -
PLOT SCALE = 40.0000' / in.	CHECKED -	REVISED -
PLOT DATE = 3/22/2019	DATE -	REVISED -

**STATE OF ILLINOIS
DEPARTMENT OF TRANSPORTATION**

SUMMARY OF QUANTITIES

SCALE: SHEET 2 OF 6 SHEETS STA. TO STA.

F.A.P. RTE.	SECTION	COUNTY	TOTAL SHEETS	SHEET NO.
836	**	=	214	5
			CONTRACT NO. 70D56	
		ILLINOIS FED. AID PROJECT		

**118RS-3,119RS-4,D5 HSIP 2019-1 *CHAMPAIGN & VERMILION

SUMMARY OF QUANTITIES

LOCATION OF WORK:	SMART			HSIP	
	FAP 836 IL-49 RURAL STA. 421+77.05 STA. 903+82.91 CHAMPAIGN CO	FAP 836 IL-49 RURAL STA.321+00.00 STA. 421+77.05 VERMILION CO	FAP 836 IL-49 RURAL STA. 421+77.05 STA. 903+82.91 CHAMPAIGN CO	FAP 836 IL-49 RURAL STA. 421+77.05 STA. 903+82.91 CHAMPAIGN CO	FAP 836 IL-49 RURAL STA.321+00.00 STA. 421+77.05 VERMILION CO
FUNDING BREAKOUT:	80% FED / 20% STATE	80% FED / 20% STATE	80% FED / 20% STATE	90% FED / 10% STATE	90% FED / 10% STATE
CONSTRUCTION TYPE CODE:	0005	0005	0054	0021	0021

CODE NO.	ITEM	UNIT	TOTAL QUANTITY	ROADWAY QUANTITY	ROADWAY QUANTITY	S.N. 010-0269 QUANTITY	SHOULDER QUANTITY	SHOULDER QUANTITY
50800105	REINFORCEMENT BARS	POUND	140.00				140.00	
51500100	NAME PLATES	EACH	2.00				2.00	
54001001	BOX CULVERT END SECTIONS, CULVERT NO. 1	EACH	2.00				2.00	
54001002	BOX CULVERT END SECTIONS, CULVERT NO. 2	EACH	2.00				2.00	
54003000	CONCRETE BOX CULVERTS	CU YD	0.50				0.50	
54011004	PRECAST CONCRETE BOX CULVERTS 10' X 4'	FOOT	78.00				78.00	
54213453	END SECTIONS 18"	EACH	1.00				1.00	
542D1063	PIPE CULVERTS, CLASS D, TYPE 2 18"	FOOT	53.00				53.00	
54260315	TRAVERSABLE PIPE GRATE FOR CONCRETE END SECTION	FOOT	512.00				512.00	
58100200	WATERPROOFING MEMBRANE SYSTEM	SQ YD	121.00			121.00		
59100100	GEOCOMPOSIT WALL DRAIN	SQ YD	40				40	
* 63000001	STEEL PLATE BEAM GUARDRAIL, TYPE A, 6 FOOT POSTS	FOOT	900				900	
* 63000370	LONG-SPAN GUARDRAIL OVER CULVERT, 25 FT SPAN	FOOT	100.00				100.00	
* 63100045	TRAFFIC BARRIER TERMINAL, TYPE 2	EACH	6.00				6.00	
* 63100085	TRAFFIC BARRIER TERMINAL, TYPE 6	EACH	4.00				4.00	
* DENOTES SPECIALTY ITEM								

MODEL: \\MODELNAME\$
FILE: \\name\$.pva | \\servername | dot.illinois.gov | PWDOT | Documents | DOT | Office | District 5 | Projects | 0570D56 | CAD | Data | Design | 0570D56-sh-S00.dgn

USER NAME = PiersonTJ	DESIGNED -	REVISED -
	DRAWN -	REVISED -
PLOT SCALE = 40.0000 ' / in.	CHECKED -	REVISED -
PLOT DATE = 3/22/2019	DATE -	REVISED -

**STATE OF ILLINOIS
DEPARTMENT OF TRANSPORTATION**

SUMMARY OF QUANTITIES

SCALE: SHEET 3 OF 6 SHEETS STA. TO STA.

F.A.P. RTE.	SECTION	COUNTY	TOTAL SHEETS	SHEET NO.
836	**	=	214	6
CONTRACT NO. 70D56				

SUMMARY OF QUANTITIES

LOCATION OF WORK:	SMART			HSIP	
	FAP 836 IL-49 RURAL STA. 421+77.05 STA. 903+82.91 CHAMPAIGN CO	FAP 836 IL-49 RURAL STA.321+00.00 STA. 421+77.05 VERMILION CO	FAP 836 IL-49 RURAL STA. 421+77.05 STA. 903+82.91 CHAMPAIGN CO	FAP 836 IL-49 RURAL STA. 421+77.05 STA. 903+82.91 CHAMPAIGN CO	FAP 836 IL-49 RURAL STA.321+00.00 STA. 421+77.05 VERMILION CO
FUNDING BREAKOUT:	80% FED / 20% STATE	80% FED / 20% STATE	80% FED / 20% STATE	90% FED / 10% STATE	90% FED / 10% STATE
CONSTRUCTION TYPE CODE:	0005	0005	0054	0021	0021

CODE NO.	ITEM	UNIT	TOTAL QUANTITY	ROADWAY QUANTITY	ROADWAY QUANTITY	S.N. 010-0269 QUANTITY	SHOULDER QUANTITY	SHOULDER QUANTITY
* 63100167	TRAFFIC BARRIER TERMINAL, TYPE 1 (SPECIAL) TANGENT	EACH	17.00				17.00	
63200310	GUARDRAIL REMOVAL	FOOT	1,908.00				1,908.00	
64200108	SHOULDER RUMBLE STRIPS, 8 INCH	FOOT	106,826.00				87,591.00	19,235.00
67000500	ENGINEER'S FIELD OFFICE, TYPE B	CAL MO	7.00	2.10	0.70	0.70	2.10	1.40
67100100	MOBILIZATION	L SUM	1.00	0.30	0.10	0.10	0.30	0.20
70100100	TRAFFIC CONTROL AND PROTECTION, STANDARD 701316	EACH	1.00	0.30	0.10	0.10	0.30	0.20
70100450	TRAFFIC CONTROL AND PROTECTION, STANDARD 701201	L SUM	1.00	0.30	0.10	0.10	0.30	0.20
70100460	TRAFFIC CONTROL AND PROTECTION, STANDARD 701306	L SUM	1.00	0.30	0.10	0.10	0.30	0.20
70106500	TEMPORARY BRIDGE TRAFFIC SIGNALS	EACH	1.00			1.00		
70300100	SHORT TERM PAVEMENT MARKING	FOOT	10,465.00	8,654.00	1,811.00			
70300220	TEMPORARY PAVEMENT MARKING - LINE 4"	FOOT	173,821.00	143,680.00	30,141.00			
* 72501000	TERMINAL MARKER - DIRECT APPLIED	EACH	17.00				17.00	
* 78001110	PAINT PAVEMENT MARKING - LINE 4"	FOOT	130,109.00	107,526.00	22,583.00			
* 78100100	RAISED REFLECTIVE PAVEMENT MARKER	EACH	775.00	647.00	128.00			
* DENOTES SPECIALTY ITEM								

MODEL: I:\MODEL\MHMS
 FILE: I:\MHMS\70D56\70D56.dgn
 PROJECT: I:\MHMS\70D56\70D56.dgn
 DESIGNED: J. Pierson
 DRAWN: J. Pierson
 CHECKED: J. Pierson
 DATE: 3/22/2019

USER NAME = PiersonTJ	DESIGNED -	REVISED -
PLOT SCALE = 40.0000 ' / in.	DRAWN -	REVISED -
PLOT DATE = 3/22/2019	CHECKED -	REVISED -
	DATE -	REVISED -

**STATE OF ILLINOIS
DEPARTMENT OF TRANSPORTATION**

SUMMARY OF QUANTITIES

SCALE: SHEET 4 OF 6 SHEETS STA. TO STA.

F.A.P. RTE. 836	SECTION **	COUNTY -	TOTAL SHEETS 214	SHEET NO. 7
			CONTRACT NO. 70D56	

SUMMARY OF QUANTITIES

LOCATION OF WORK:	SMART			HSIP	
	FAP 836 IL-49 RURAL STA. 421+77.05 STA. 903+82.91 CHAMPAIGN CO	FAP 836 IL-49 RURAL STA.321+00.00 STA. 421+77.05 VERMILION CO	FAP 836 IL-49 RURAL STA. 421+77.05 STA. 903+82.91 CHAMPAIGN CO	FAP 836 IL-49 RURAL STA. 421+77.05 STA. 903+82.91 CHAMPAIGN CO	FAP 836 IL-49 RURAL STA.321+00.00 STA. 421+77.05 VERMILION CO
FUNDING BREAKOUT:	80% FED / 20% STATE	80% FED / 20% STATE	80% FED / 20% STATE	90% FED / 10% STATE	90% FED / 10% STATE
CONSTRUCTION TYPE CODE:	0005	0005	0054	0021	0021

CODE NO.	ITEM	UNIT	TOTAL QUANTITY	ROADWAY QUANTITY	ROADWAY QUANTITY	S.N. 010-0269 QUANTITY	SHOULDER QUANTITY	SHOULDER QUANTITY
*	78200005	GUARDRAIL REFLECTORS, TYPE A	EACH	33.00			33.00	
	78300200	RAISED REFLECTIVE PAVEMENT MARKER REMOVAL	EACH	775.00	647.00	128.00		
	X0327584	GRADING AND SHAPING SHOULDERS, SPECIAL	FOOT	109,258.00			90,023.00	19,235.00
	X0900064	MEMBRANE WATERPROOFING SYSTEM FOR BURIED STRUCTURES	SQ YD	40.00			40.00	
	X1200050	BOX CULVERT REMOVAL	FOOT	59.00			59.00	
	X4400196	HOT-MIX ASPHALT SURFACE REMOVAL, SPECIAL	SQ YD	2,003.00	1,194.00	39.00	432.00	338.00
	X4811900	AGGREGATE SHOULDERS (SPECIAL)	TON	615.00			615.00	
*	X6310188	TRAFFIC BARRIER TERMINAL, TYPE 6A (MODIFIED)	EACH	8.00			8.00	
*	X6330725	STEEL PLATE BEAM GUARDRAIL (SHORT RADIUS)	FOOT	75.00			75.00	
	X7240600	REMOVE AND RE-ERECT EXISTING SIGN	EACH	2.00			2.00	
*	XZ193400	SURVEY MARKER, TYPE 2 (SPECIAL)	EACH	7.00	7.00			
	Z0004556	HOT-MIX ASPHALT SURFACE REMOVAL (DECK)	SQ YD	121.00		121.00		
	Z0013798	CONSTRUCTION LAYOUT	L SUM	1.00	0.30	0.10	0.10	0.30
	Z0016200	DECK SLAB REPAIR (PARTIAL)	SQ YD	9.00		9.00		
* DENOTES SPECIALTY ITEM								

MODEL: I:\MODEL\MHFS
FILE: MHFS_Plan\I18R5-3,119RS-4,05 HSIP 2019-1.dwg
PROJECT: I:\Projects\0570D56\CADD\Drawings\0570D56-ht-500.dwg

USER NAME = PiersonTJ	DESIGNED -	REVISED -
	DRAWN -	REVISED -
PLOT SCALE = 40.0000 ' / in.	CHECKED -	REVISED -
PLOT DATE = 3/22/2019	DATE -	REVISED -

**STATE OF ILLINOIS
DEPARTMENT OF TRANSPORTATION**

SUMMARY OF QUANTITIES

SCALE: SHEET 5 OF 6 SHEETS STA. TO STA.

F.A.P. RTE.	SECTION	COUNTY	TOTAL SHEETS	SHEET NO.
836	**	-	214	8
CONTRACT NO. 70D56				

EXISTING TYPICAL CROSS SECTION

STA. 321+00.00	TO	STA. 378+40.28
STA. 383+34.45	TO	STA. 420+39.54
STA. 428+94.95	TO	STA. 466+45.71
STA. 471+94.89	TO	STA. 472+14.79
STA. 479+34.51	TO	STA. 686+25.31
STA. 690+78.11	TO	STA. 727+22.86
STA. 731+76.98	TO	STA. 903+82.91

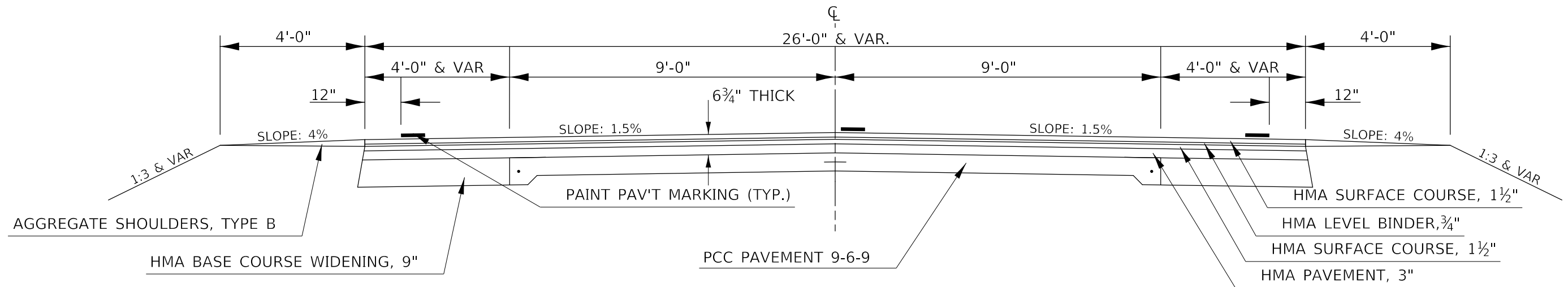

PROPOSED TYPICAL CROSS SECTION ①

STA. 321+00.00	TO	STA. 378+40.28 ②
② STA. 383+34.45	TO	STA. 420+39.54 ④
④ STA. 428+94.95	TO	STA. 466+45.71 ④
④ STA. 471+94.89	TO	STA. 472+14.79 ⑤
⑤ STA. 479+34.51	TO	STA. 686+25.31 ⑥
② STA. 690+78.11	TO	STA. 727+22.86 ⑦
⑦ STA. 731+76.98	TO	STA. 903+82.91

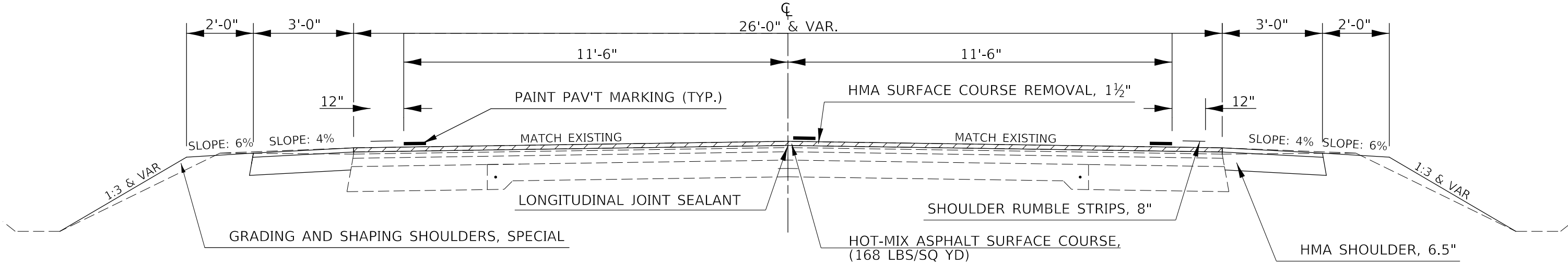

MODEL: \\MODEL\MARTE... FILE: \\MARTE... \Projects\0570D56\CADD\Drawings\0570D56-01-Typical_Cross_Sections.dgn

USER NAME = PiersonJ	DESIGNED -	REVISED -
PLOT SCALE = 3,000' / in.	DRAWN -	REVISED -
PLOT DATE = 3/22/2019	CHECKED -	REVISED -
	DATE -	REVISED -

STATE OF ILLINOIS
DEPARTMENT OF TRANSPORTATION

IL-49 TYPICAL CROSS-SECTIONS

SCALE: N.T.S. SHEET 1 OF 7 SHEETS STA. TO STA.

F.A.P. RTE.	SECTION	COUNTY	TOTAL SHEETS	SHEET NO.
836	**	-	214	10
CONTRACT NO. 70D56				

EXISTING TYPICAL CROSS SECTION

BRIDGE OMISSION:
STA. 687+75.55 TO STA. 689+45.60

STA. 378+40.28 TO STA. 380+47.00
 STA. 381+14.00 TO STA. 383+34.45
 STA. 686+75.29 TO STA. 690+78.11

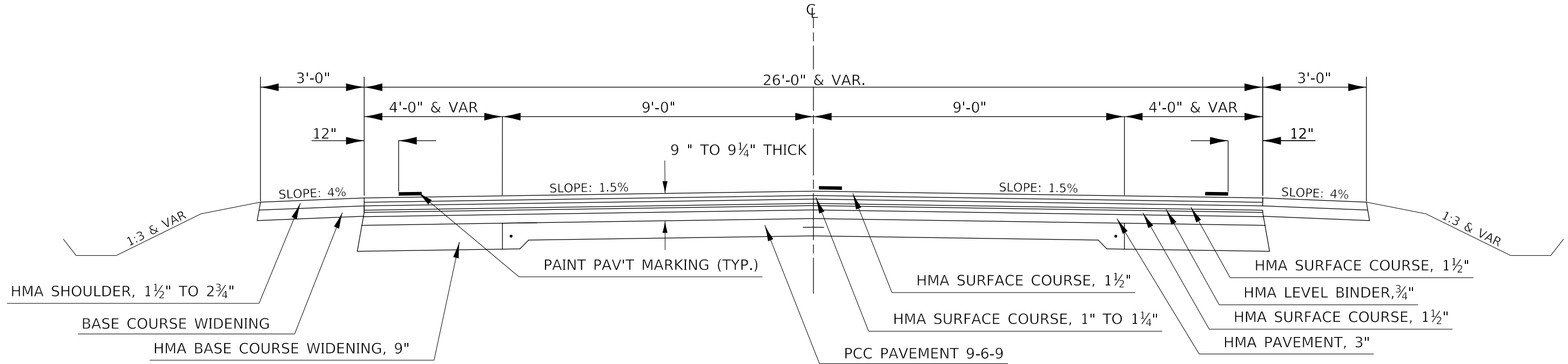

PROPOSED TYPICAL CROSS SECTION ②

BRIDGE OMISSION:
STA. 687+75.55 TO STA. 689+45.60

① STA. 378+40.28 TO STA. 380+47.00 ③
 ③ STA. 381+14.00 TO STA. 383+34.45 ①
 ⑥ STA. 686+75.29 TO STA. 690+78.11 ①

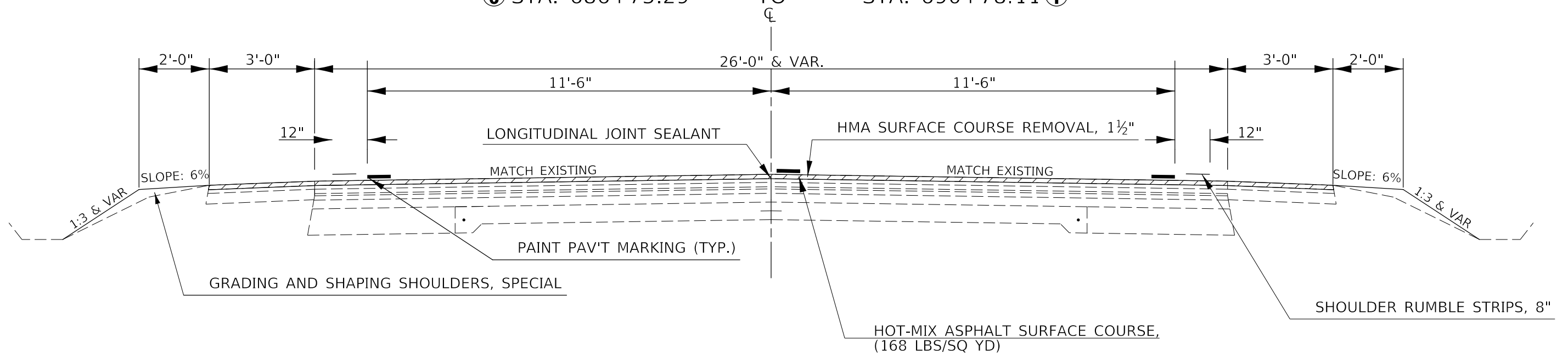

MODEL: \\MODEL\MARIS
FILE: \\MARIS_Plan\p118rs-3_119rs-4_D5_HSP19-1\Typical_Cross_Section.dgn

USER NAME = PiersonJ	DESIGNED -	REVISED -
PLOT SCALE = 3,000' / in.	DRAWN -	REVISED -
PLOT DATE = 3/22/2019	CHECKED -	REVISED -
	DATE -	REVISED -

**STATE OF ILLINOIS
DEPARTMENT OF TRANSPORTATION**

IL-49 TYPICAL CROSS-SECTIONS

SCALE: N.T.S. SHEET 2 OF 7 SHEETS STA. TO STA.

F.A.P. RTE.	SECTION	COUNTY	TOTAL SHEETS	SHEET NO.
836	**	*	214	11
CONTRACT NO. 70D56				

EXISTING TYPICAL CROSS SECTION

STA. 380+47.00 TO STA. 381+14.00

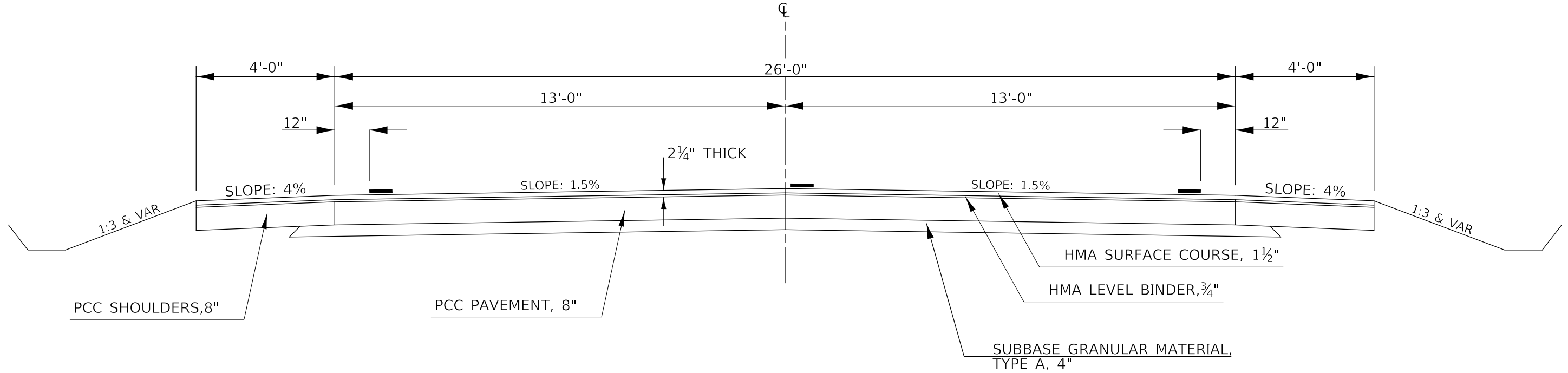

PROPOSED TYPICAL CROSS SECTION ③

② STA. 380+47.00 TO STA. 381+14.00 ②

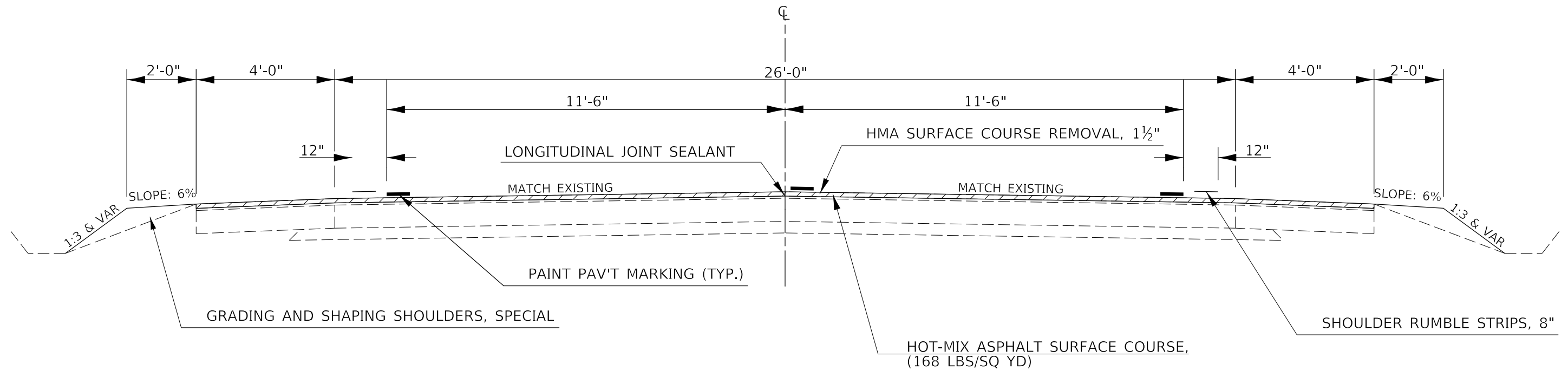

MODEL: \\MODEL\MAT\... FILE: \\mat\c... \Project\0570D56\CADD\Drawings\0570D56-PL-Typical Cross Sections.dgn

USER NAME = PiersonJ	DESIGNED -	REVISED -
PLOT SCALE = 3,000' / in.	DRAWN -	REVISED -
PLOT DATE = 3/22/2019	CHECKED -	REVISED -
	DATE -	REVISED -

**STATE OF ILLINOIS
DEPARTMENT OF TRANSPORTATION**

IL-49 TYPICAL CROSS-SECTIONS

SCALE: N.T.S. SHEET 3 OF 7 SHEETS STA. TO STA.

F.A.P. RTE.	SECTION	COUNTY	TOTAL SHEETS	SHEET NO.
836	**	-	214	12
CONTRACT NO. 70D56				

EXISTING TYPICAL CROSS SECTION

STA. 420+39.54 TO STA. 428+94.95
 STA. 466+45.71 TO STA. 471+94.89

℄

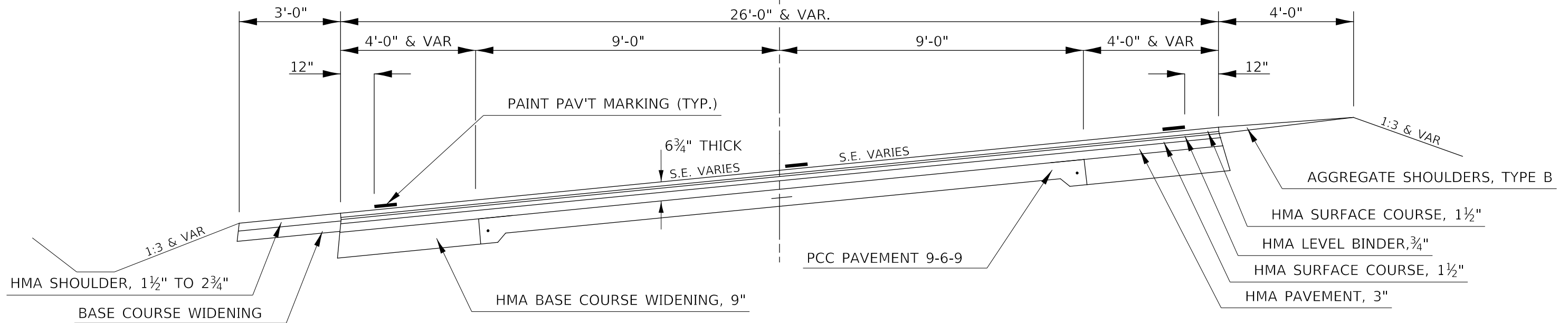

PROPOSED TYPICAL CROSS SECTION ④

① STA. 420+39.54 TO STA. 428+94.95 ①
 ① STA. 466+45.71 TO STA. 471+94.89 ①

℄

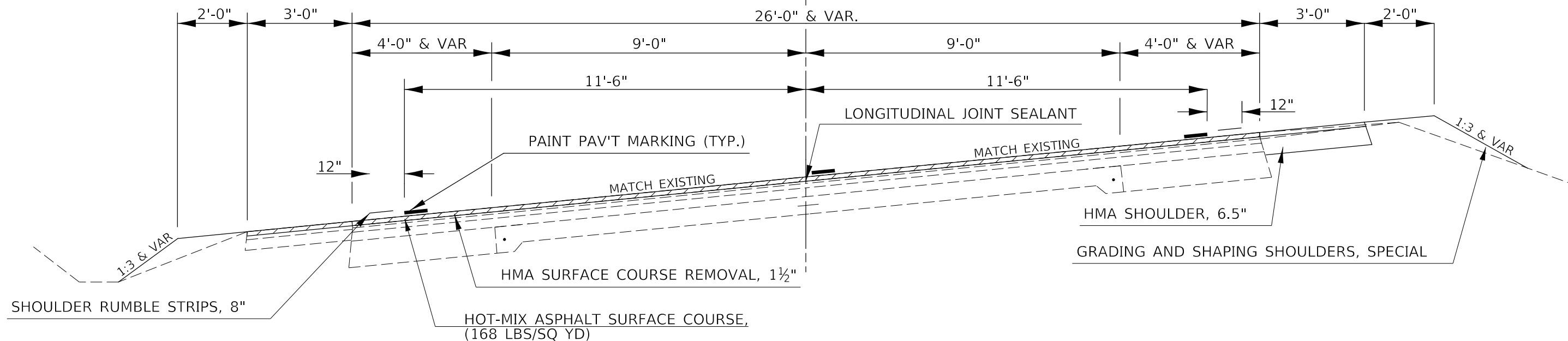

MODEL: \\MODEL\MAR\F... FILE: \\MAR\F... \Projects\0570D56\CADD\Design\0570D56-01-Typical_Cross_Sections.dgn

USER NAME = PiersonTJ	DESIGNED -	REVISD -
DRAWN -	REVISD -	REVISD -
PLOT SCALE = 3,000' / in.	CHECKED -	REVISD -
PLOT DATE = 3/22/2019	DATE -	REVISD -

**STATE OF ILLINOIS
 DEPARTMENT OF TRANSPORTATION**

IL-49 TYPICAL CROSS-SECTIONS

SCALE: N.T.S. SHEET 4 OF 7 SHEETS STA. TO STA.

F.A.P. RTE. 836	SECTION **	COUNTY -	TOTAL SHEETS 214	SHEET NO. 13
			CONTRACT NO. 70D56	

EXISTING TYPICAL CROSS SECTION
 STA. 472+14.79 TO STA. 479+34.51

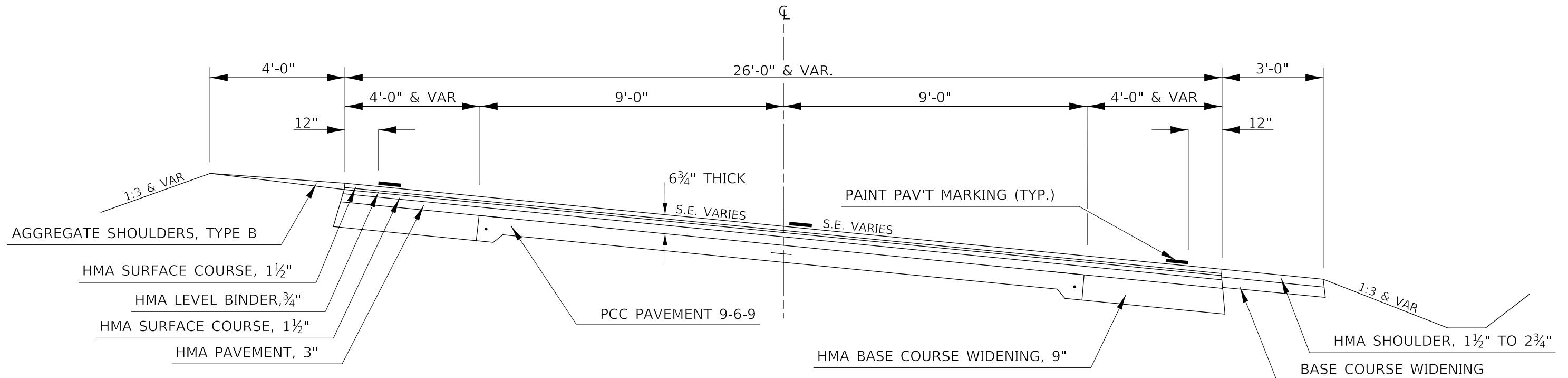

PROPOSED TYPICAL CROSS SECTION ⑤

① STA. 472+14.79 TO STA. 479+34.51 ①

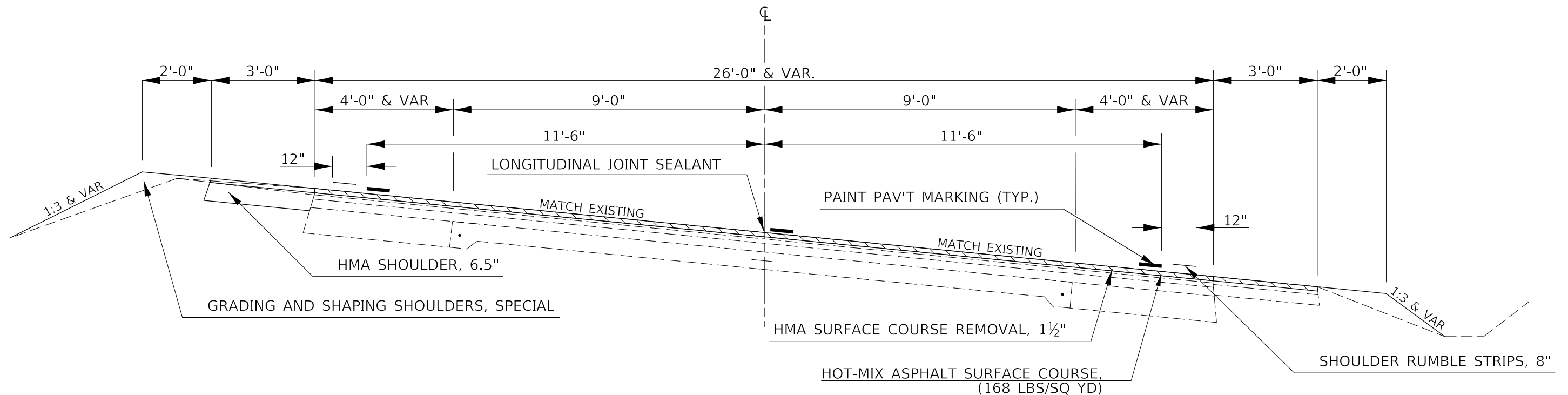

MODEL: \\MODEL\MAR\F...
 FILE: \\MAR\F...
 PROJECT: \\PROJECTS\70D56\CADD\DATA\Design\70D56-4-1-Typical_Cross_Section.dgn

USER NAME = PiersonJ	DESIGNED -	REVISED -
	DRAWN -	REVISED -
PLOT SCALE = 3,0000' / in.	CHECKED -	REVISED -
PLOT DATE = 3/22/2019	DATE -	REVISED -

**STATE OF ILLINOIS
 DEPARTMENT OF TRANSPORTATION**

IL-49 TYPICAL CROSS-SECTIONS

SCALE: N.T.S. SHEET 5 OF 7 SHEETS STA. TO STA.

F.A.P. RTE.	SECTION	COUNTY	TOTAL SHEETS	SHEET NO.
836	**	-	214	14
CONTRACT NO. 70D56				

EXISTING TYPICAL CROSS SECTION

STA. 686+25.31 TO STA. 686+75.29

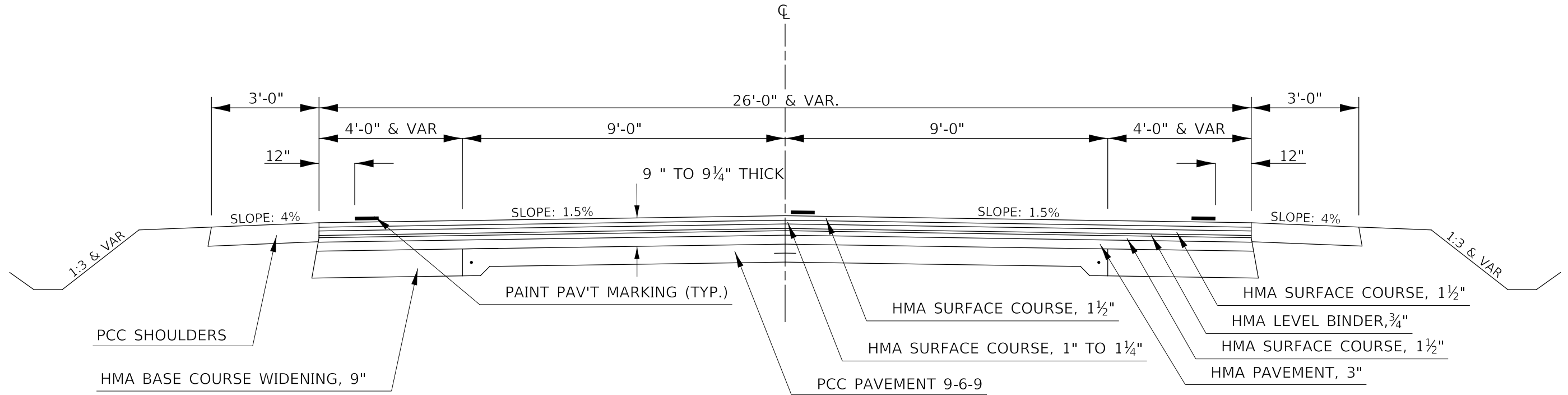

PROPOSED TYPICAL CROSS SECTION ⑥

① STA. 686+25.31 TO STA. 686+75.29 ②

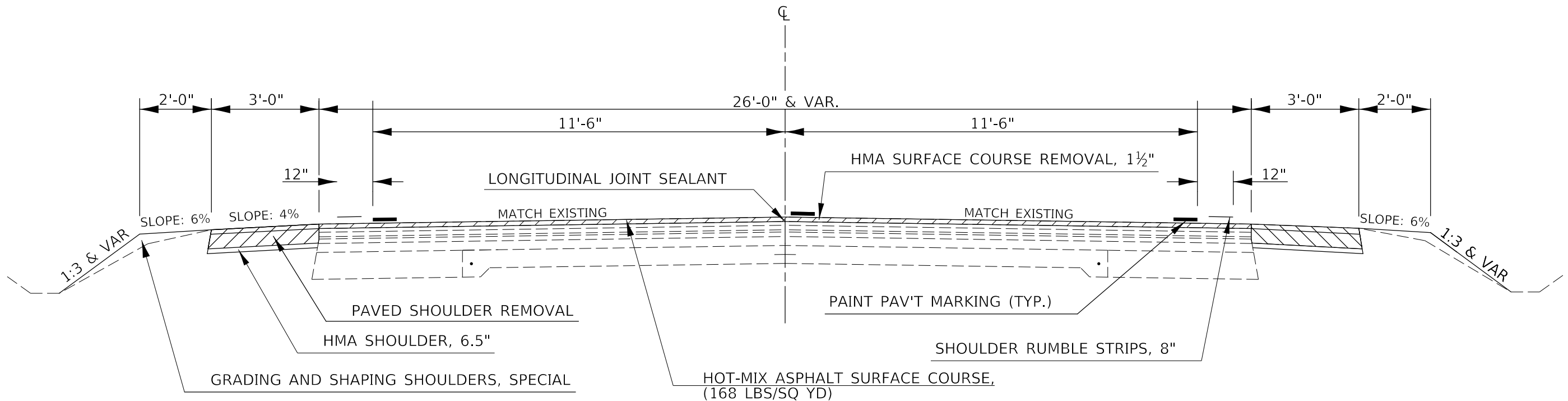

MODEL: \\MODEL\MAR\F... FILE: \\MAR\F... \Projects\0570D56\CADD\Drawings\0570D56-01-Typical_Cross_Sections.dgn

USER NAME = PiersonJ	DESIGNED -	REVISED -
PLOT SCALE = 3,000' / in.	DRAWN -	REVISED -
PLOT DATE = 3/22/2019	CHECKED -	REVISED -
	DATE -	REVISED -

**STATE OF ILLINOIS
DEPARTMENT OF TRANSPORTATION**

IL-49 TYPICAL CROSS-SECTIONS

SCALE: N.T.S. SHEET 6 OF 7 SHEETS STA. TO STA.

F.A.P. RTE.	SECTION	COUNTY	TOTAL SHEETS	SHEET NO.
836	**	*	214	15
CONTRACT NO. 70D56				

**118RS-3,119RS-4,D5 HSIP 2019-1

*CHAMPAIGN & VERMILION

EXISTING TYPICAL CROSS SECTION

BRIDGE OMISSION:
STA. 729+32.48 TO STA. 729+65.24

STA. 727+22.86 TO STA. 731+76.98

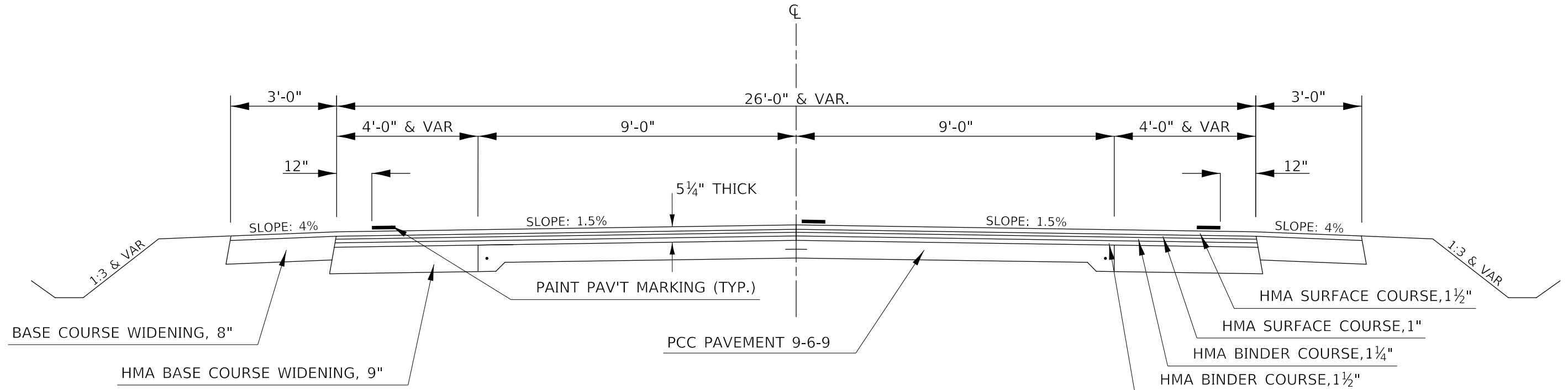

PROPOSED TYPICAL CROSS SECTION ⑦

BRIDGE OMISSION:
STA. 729+32.48 TO STA. 729+65.24

① STA. 727+22.86 TO STA. 731+76.98 ①

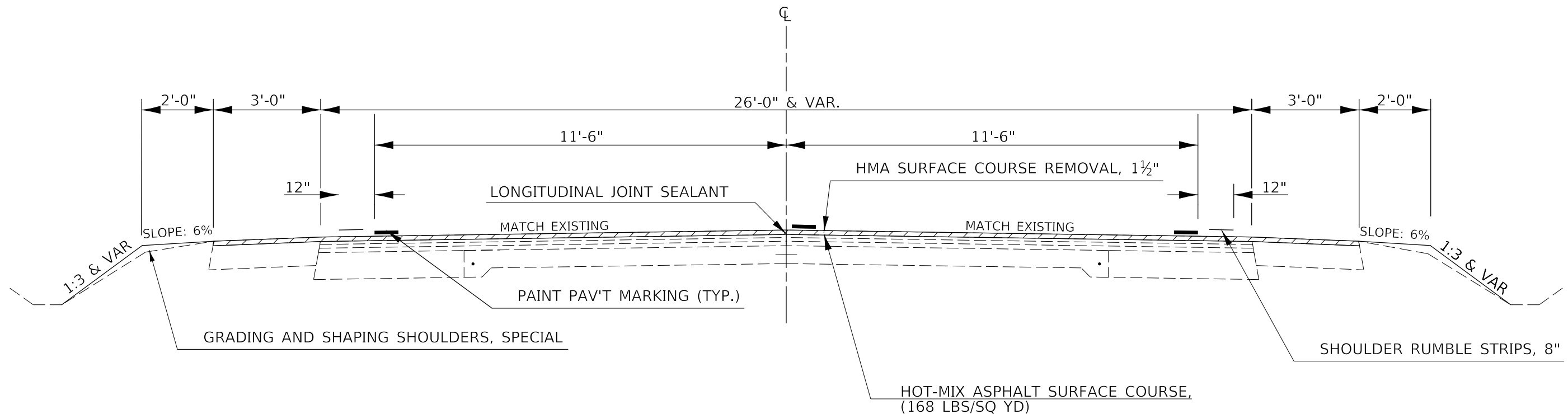

MODEL: \\MODEL\MARTE
FILE: \\MARTE_Plan\p118rs\03119rs-4\05\HSP\2019-1\118RS-3,119RS-4,05\HSP\2019-1\Typical_Cross_Sections.dgn

USER NAME = PiersonTJ	DESIGNED -	REVISED -
PLOT SCALE = 3,000' / in.	DRAWN -	REVISED -
PLOT DATE = 3/22/2019	CHECKED -	REVISED -
	DATE -	REVISED -

**STATE OF ILLINOIS
DEPARTMENT OF TRANSPORTATION**

IL-49 TYPICAL CROSS-SECTIONS

SCALE: N.T.S. SHEET 7 OF 7 SHEETS STA. TO STA.

F.A.P. RTE.	SECTION	COUNTY	TOTAL SHEETS	SHEET NO.
836	**	*	214	16
CONTRACT NO. 70D56				

SCHEDULE OF QUANTITIES

NB EARTHWORK SCHEDULE																															
STA	TO	STA	LENGTH FT	OMISSION REASON	STATION 1											STATION 2						TOTAL FILL CU YD	AGG NEEDED IN FILL CU YD	EARTH NEEDED IN FILL CU YD	EXISTING AGG AVAILABLE CU YD	EXISTING TILLED EARTH CU YD	HSIP 20200100 EARTH EXCAVATION CU YD	EMBANKMENT CU YD	AGGREGATE EMBANKMENT CU YD	EARTHWORK BALANCE WASTE (+) OR SHORTAGE (-) CU YD	AGGREGATE BALANCE WASTE (+) OR SHORTAGE (-) CU YD
					(A)	(B)	(C)	(D)	(E)	(F)	(A)	(B)	(C)	(D)	(E)	(F)															
					AGG REM. FOR HMA SHLDR SQ FT	VEG. REMOVAL SQ FT	EARTH- WORK FILL SQ FT	EARTH- WORK CUT SQ FT	4 IN TILLED SQ FT	TOTAL AREA SQ FT	AGG REM. FOR HMA SHLDR SQ FT	VEG. REMOVAL SQ FT	EARTH- WORK FILL SQ FT	EARTH- WORK CUT SQ FT	4 IN TILLED SQ FT	TOTAL AREA SQ FT															
321+00.00	TO	330+00.00	900.00		2.25	0.63	0.48	0	2.53	3.64	1.77	0.48	0.8	0	1.93	3.21	114.17	45.67	68.50	67.00	74.33	72.83	0.00	0.00	5.83	21.33					
330+00.00	TO	340+00.00	1000.00		1.77	0.48	0.8	0	1.93	3.21	1.59	0.38	1.37	0	1.51	3.26	119.81	47.92	71.89	62.22	63.70	62.22	8.19	0.00	-8.19	14.30					
340+00.00	TO	350+00.00	1000.00		1.59	0.38	1.37	0	1.51	3.26	1.78	0.42	0.81	0.17	1.66	2.72	110.74	44.30	66.44	62.41	58.70	62.41	7.74	0.00	-7.74	18.11					
350+00.00	TO	360+00.00	1000.00		1.78	0.42	0.81	0.17	1.66	2.72	1.68	0.38	1.65	0	1.51	3.54	115.93	46.37	69.56	64.07	58.70	64.07	10.86	0.00	-10.86	17.70					
360+00.00	TO	370+00.00	1000.00		1.68	0.38	1.65	0	1.51	3.54	1.61	0.45	1.28	0	1.8	3.53	130.93	52.37	78.56	60.93	61.30	60.93	17.26	0.00	-17.26	8.56					
370+00.00	TO	373+56.52	356.52		1.61	0.45	1.28	0	1.8	3.53	2.26	0.89	0.86	0	2.72	4.47	52.82	21.13	31.69	25.55	29.84	25.55	1.85	0.00	-1.85	4.42					
373+56.52	TO	373+90.27	33.75	E 200 N RD	2.26	0.89	0.86	0	2.72	4.47	2.33	1.07	0.29	0	3.11	4.47	0.00	0.00	0.00	0.00	0.00	0.00	0.00	0.00	0.00	0.00	0.00				
373+90.27	TO	378+43.55	453.28		2.33	1.07	0.29	0	3.11	4.47	2.43	1.23	0.16	0	3.65	5.04	79.83	31.93	47.90	39.96	56.74	48.80	0.00	0.00	8.84	8.03					
378+43.55	TO	383+34.45	490.90	SN 092-8616	2.43	1.23	0.16	0	3.65	5.04	2.41	1.18	0.92	0	3.54	5.64	97.09	38.84	58.25	0.00	65.36	7.11	0.00	38.84	7.11	-38.84					
383+34.45	TO	390+00.00	665.55		2.41	1.18	0.92	0	3.54	5.64	1.92	0.4	0.68	0	1.63	2.71	102.91	41.16	61.75	53.37	63.72	55.34	0.00	0.00	1.97	12.21					
390+00.00	TO	405+00.00	1500.00		1.92	0.4	0.68	0	1.63	2.71	2.31	0.35	0.24	0	1.41	2	130.83	52.33	78.50	117.50	84.44	123.44	0.00	0.00	5.94	65.17					
405+00.00	TO	410+00.00	500.00		2.31	0.35	0.24	0	1.41	2	1.96	0.39	0.83	0	1.53	2.75	43.98	17.59	26.39	39.54	27.22	40.37	0.00	0.00	0.83	21.95					
410+00.00	TO	420+00.00	1000.00		1.96	0.39	0.83	0	1.53	2.75	3.28	0.32	0	0	0.57	0.89	67.41	26.96	40.45	97.04	38.89	97.04	1.56	0.00	-1.56	70.08					
420+00.00	TO	420+37.80	37.80		3.28	0.32	0	0	0.57	0.89	3.28	0.32	0	0	0.57	0.89	1.25	0.50	0.75	4.59	0.80	4.64	0.00	0.00	0.05	4.09					
420+37.80	TO	423+24.54	286.74	ALLERTON	3.28	0.32	0	0	0.57	0.89	2.9	0.32	0	0	0.57	0.89	0.00	0.00	0.00	0.00	0.00	0.00	0.00	0.00	0.00	0.00					
VERMILION COUNTY NB SUB-TOTALS =																						724.75	47.46	38.84	-16.89	227.11					
423+24.54	TO	427+41.88	417.34		2.9	0.32	0	0	0.57	0.89	2.56	0.32	0	0	0.57	0.89	13.76	5.50	8.26	42.20	8.81	42.75	0.00	0.00	0.55	36.70					
427+41.88	TO	428+41.09	99.21	E YATES ST	2.56	0.32	0	0	0.57	0.89	2.1	1.38	1.81	0	4.1	7.29	0.00	0.00	0.00	0.00	0.00	0.00	0.00	0.00	0.00	0.00					
428+41.09	TO	430+00.00	158.91		2.1	1.38	1.81	0	4.1	7.29	3.55	0.96	1.24	0	4.1	6.3	39.99	16.00	23.99	16.63	24.13	16.77	0.00	0.00	0.14	0.63					
430+00.00	TO	440+00.00	1000.00		3.55	0.96	1.24	0	4.1	6.3	2.09	0.58	1.83	0	2.31	4.72	204.07	81.63	122.44	104.44	118.70	104.44	3.74	0.00	-3.74	22.81					
440+00.00	TO	450+00.00	1000.00		2.09	0.58	1.83	0	2.31	4.72	2.15	0.46	1.06	0	1.83	3.35	149.44	59.78	89.66	78.52	76.67	78.52	12.99	0.00	-12.99	18.74					
450+00.00	TO	460+00.00	1000.00		2.15	0.46	1.06	0	1.83	3.35	1.68	0.5	1.46	0	1.98	3.94	135.00	54.00	81.00	70.93	70.56	70.93	10.44	0.00	-10.44	16.93					
460+00.00	TO	467+98.05	798.05		1.68	0.5	1.46	0	1.98	3.94	2.6	1.05	0.15	0	3.52	4.72	127.98	51.19	76.79	63.25	81.28	67.74	0.00	0.00	4.49	12.06					
467+98.05	TO	468+49.71	51.66	SMALL ROAD NO EX AGG SHOULDER	2.6	1.05	0.15	0	3.52	4.72	2.56	0.32	0	0	0.57	0.89	5.37	2.15	3.22	0.00	3.91	0.69	0.00	2.15	0.69	-2.15					
468+49.71	TO	472+42.07	392.36		2.56	0.32	0	0	0.57	0.89	2.84	0.32	0	0	0.57	0.8867	12.91	5.16	7.75	0.00	8.28	0.53	0.00	5.16	0.53	-5.16					
472+42.07	TO	479+34.62	692.55	EXISTING HMA SHOULDER	2.84	0.32	0	0	0.57	0.8867	1.85	0.82	3.14	0	3.18	7.14	102.94	41.18	61.76	25.65	48.09	25.65	13.67	15.53	-13.67	-15.53					
479+34.62	TO	480+00.00	65.38		1.85	0.82	3.14	0	3.18	7.14	1.85	0.84	2.85	0	3.18	6.87	16.96	6.78	10.18	4.48	7.70	4.48	2.48	2.30	-2.48	-2.30					
480+00.00	TO	490+00.00	1000.00		1.85	0.84	2.85	0	3.18	6.87	2.03	1.09	3.6	0	4.34	9.03	294.44	117.78	176.66	71.85	139.26	71.85	37.40	45.93	-37.40	-45.93					
490+00.00	TO	500+00.00	1000.00		2.03	1.09	3.6	0	4.34	9.03	2.07	0.71	0.59	0	2.87	4.17	244.44	97.78	146.66	75.93	133.52	75.93	13.14	21.85	-13.14	-21.85					
500+00.00	TO	510+00.00	1000.00		2.07	0.71	0.59	0	2.87	4.17	1.88	0.46	1.11	0	1.82	3.39	140.00	56.00	84.00	73.15	86.85	76.00	0.00	0.00	2.85	17.15					
510+00.00	TO	520+00.00	1000.00		1.88	0.46	1.11	0	1.82	3.39	1.69	0.56	2.01	0	2.28	4.85	152.59	61.04	91.55	66.11	75.93	66.11	15.62	0.00	-15.62	5.07					
520+00.00	TO	530+00.00	1000.00		1.69	0.56	2.01	0	2.28	4.85	1.97	0.52	0.87	0	2.13	3.52	155.00	62.00	93.00	67.78	81.67	67.78	11.33	0.00	-11.33	5.78					
530+00.00	TO	531+78.49	178.49		1.97	0.52	0.87	0	2.13	3.52	2.4	0.57	0.37	0	2.36	3.3	22.54	9.02	13.52	14.44	14.84	15.76	0.00	0.00	1.32	5.42					
531+78.49	TO	532+12.14	33.65	CR 300	2.4	0.57	0.37	0	2.36	3.3	2.28	0.59	0.24	0	2.34	3.17	0.00	0.00	0.00	0.00	0.00	0.00	0.00	0.00	0.00	0.00	0.00				
532+12.14	TO	540+00.00	787.86		2.28	0.59	0.24	0	2.34	3.17	1.9	0.52	0.53	0	2.07	3.12	91.77	36.71	55.06	60.99	64.34	70.27	0.00	0.00	9.28	24.28					
540+00.00	TO	550+00.00	1000.00		1.9	0.52	0.53	0	2.07	3.12	1.78	0.35	1.12	0	1.39	2.86	110.74	44.30	66.44	68.15	64.07	68.15	2.37	0.00	-2.37	23.85					
550+00.00	TO	560+00.00	1000.00		1.78	0.35	1.12	0	1.39	2.86	1.62	0.6	2.26	0	2.42	5.28	150.74	60.30	90.44	62.96	70.56	62.96	19.88	0.00	-19.88	2.66					
560+00.00	TO	570+00.00	1000.00		1.62	0.6	2.26	0	2.42	5.28	2.13	0.76	0.4	0	3.07	4.23	176.11	70.44	105.67	69.44	101.67	69.44	4.00	1.00	-4.00	-1.00					
570+00.00	TO	571+38.49	138.49		2.13	0.76	0.4	0	3.07	4.23	2.37	1.13	0.18	0.63	4.25	4.93	23.49	9.40	14.09	11.54	18.77	16.22	0.00	0.00	4.68	2.14					
571+38.49	TO	571+72.59	34.10	CR 375	2.37	1.13	0.18	0.63	4.25	4.93	1.96	0.69	1.16	0	2.58	4.43	0.00	0.00	0.00	0.00	0.00	0.00	0.00	0.00	0.00	0.00					
571+72.59	TO	580+00.00	827.41		1.96	0.69	1.16	0	2.58	4.43	2.07	0.4	0.66	0	1.61	2.67	108.79	43.52	65.27	61.75	64.20	61.75	1.07	0.00	-1.07	18.23					
580+00.00	TO	590+00.00	1000.00		2.07	0.4	0.66	0	1.61	2.67	1.66	0.33	1.25	0	1.32	2.9	103.1														

SCHEDULE OF QUANTITIES

NB EARTHWORK SCHEDULE

STA	TO	STA	LENGTH FT	OMISSION REASON	STATION 1										STATION 2						(G)	(H)	(I)	(J)	(K)	(L)	(M)	(N)		EARTHWORK BALANCE WASTE (+) OR SHORTAGE (-) CU YD	AGGREGATE BALANCE WASTE (+) OR SHORTAGE (-) CU YD				
					(A)	(B)	(C)	(D)	(E)	(F)	(A)	(B)	(C)	(D)	(E)	(F)	TOTAL FILL CU YD	AGG NEEDED IN FILL CU YD	EARTH NEEDED IN FILL CU YD	EXISTING AGG AVAILABLE CU YD								EXISTING TILLED EARTH CU YD	HSIP 20200100 EARTH EXCAVATION CU YD			EARTH EMBANKMENT CU YD	AGGREGATE EMBANKMENT CU YD	EARTHWORK BALANCE WASTE (+) OR SHORTAGE (-) CU YD	AGGREGATE BALANCE WASTE (+) OR SHORTAGE (-) CU YD
					AGG REM. FOR HMA SHLDR SQ FT	VEG. REMOVAL SQ FT	EARTH- WORK FILL SQ FT	EARTH- WORK CUT SQ FT	4 IN TILLED SQ FT	TOTAL AREA SQ FT	AGG REM. FOR HMA SHLDR SQ FT	VEG. REMOVAL SQ FT	EARTH- WORK FILL SQ FT	EARTH- WORK CUT SQ FT	4 IN TILLED SQ FT	TOTAL AREA SQ FT																			
					CU YD	CU YD	CU YD	CU YD	CU YD	CU YD	CU YD	CU YD	CU YD	CU YD	CU YD	CU YD																			
660+00.00	TO	664+23.95	423.95		1.94	0.95	1.4	0	3.75	6.1	2.29	0.79	2.52	0.52	3.24	6.03	95.23	38.09	57.14	33.21	54.88	33.21	2.26	4.88	-2.26	-4.88									
664+23.95	TO	664+99.19	75.24	SN 010-0236	2.29	0.79	2.52	0.52	3.24	6.03	2.53	2.09	0.15	0	8.12	10.36	0.00	0.00	0.00	0.00	0.00	0.00	0.00	0.00	0.00	0.00	0.00								
664+99.19	TO	670+00.00	500.81		2.53	2.09	0.15	0	8.12	10.36	1.78	2.15	3.61	0	8.49	14.25	228.24	91.30	136.94	39.97	154.05	57.08	0.00	51.33	17.11	-51.33									
670+00.00	TO	680+00.00	1000.00		1.78	2.15	3.61	0	8.49	14.25	2	2.27	2.74	0	9.03	14.04	523.89	209.56	314.33	70.00	324.44	80.11	0.00	139.56	10.11	-139.56									
680+00.00	TO	686+26.44	626.44		2	2.27	2.74	0	9.03	14.04	2.4	3.26	0.15	2.26	11.35	12.5	307.88	123.15	184.73	51.04	236.42	102.73	0.00	72.11	51.69	-72.11									
686+26.44	TO	686+75.09	48.65	EXISTING PCC SHOULDER	2.4	3.26	0.15	2.26	11.35	12.5	2.4	3.26	0.15	2.26	11.35	12.497	22.52	9.01	13.51	0.00	20.45	6.94	0.00	9.01	6.94	-9.01									
686+75.09	TO	690+77.85	402.76	SN 010-0284	2.4	3.26	0.15	2.26	11.35	12.497	2.48	3.92	0	3.73	4.18	4.37	0.00	0.00	0.00	0.00	0.00	0.00	0.00	0.00	0.00	0.00									
690+77.85	TO	700+00.00	922.15		2.48	3.92	0	3.73	4.18	4.37	1.88	1.06	2.62	0	4.29	7.97	210.73	84.29	126.44	74.46	144.64	92.66	0.00	9.83	18.20	-9.83									
700+00.00	TO	710+00.00	1000.00		1.88	1.06	2.62	0	4.29	7.97	2.09	0.61	0.38	0.14	2.45	3.3	208.70	83.48	125.22	73.52	124.81	73.52	0.41	9.96	-0.41	-9.96									
710+00.00	TO	720+00.00	1000.00		2.09	0.61	0.38	0.14	2.45	3.3	1.85	0.58	1.13	0	2.31	4.02	135.56	54.22	81.34	72.96	88.15	79.77	0.00	0.00	6.81	18.74									
720+00.00	TO	727+19.28	719.28		1.85	0.58	1.13	0	2.31	4.02	2.46	0.64	0.08	0	2.57	3.29	97.37	38.95	58.42	57.41	65.00	63.99	0.00	0.00	6.58	18.46									
727+19.28	TO	729+30.49	211.21	EXISTING HMA SHOULDER	2.46	0.64	0.08	0	2.57	3.29	2.46	0.64	0.08	0	2.57	3.287	25.72	10.29	15.43	0.00	20.10	4.67	0.00	10.29	4.67	-10.29									
729+30.49	TO	729+66.49	36.00	SN 010-0269	2.46	0.64	0.08	0	2.57	3.287	2.46	0.64	0.08	0	2.57	3.287	4.38	1.75	2.63	3.28	3.43	4.08	0.00	0.00	0.80	1.53									
729+66.49	TO	731+76.88	210.39	EXISTING HMA SHOULDER	2.46	0.64	0.08	0	2.57	3.287	1.98	0.74	2.29	0	2.96	5.987	36.13	14.45	21.68	0.00	21.55	0.00	0.13	14.45	-0.13	-14.45									
731+76.88	TO	740+00.00	823.12		1.98	0.74	2.29	0	2.96	5.987	1.86	0.68	1.02	0	2.69	4.39	158.18	63.27	94.91	58.53	86.12	58.53	8.79	4.74	-8.79	-4.74									
740+00.00	TO	744+00.95	400.95		1.86	0.68	1.02	0	2.69	4.39	2.49	0.59	0	0.11	2.26	2.74	52.94	21.18	31.76	32.30	36.75	37.29	0.00	0.00	4.99	11.12									
744+00.95	TO	744+50.64	49.69	CR 700	2.49	0.59	0	0.11	2.26	2.74	2.41	0.57	0.14	0	2.27	2.98	0.00	0.00	0.00	0.00	0.00	0.00	0.00	0.00	0.00	0.00									
744+50.64	TO	750+00.00	549.36		2.41	0.57	0.14	0	2.27	2.98	2.2	0.56	0.41	0	2.25	3.22	63.07	25.23	37.84	46.90	45.98	55.04	0.00	0.00	8.14	21.67									
750+00.00	TO	760+00.00	1000.00		2.2	0.56	0.41	0	2.25	3.22	2.11	0.44	0.51	0	1.75	2.7	109.63	43.85	65.78	79.81	74.07	88.10	0.00	0.00	8.29	35.96									
760+00.00	TO	770+00.00	1000.00		2.11	0.44	0.51	0	1.75	2.7	2.2	1.14	0.83	0	4.53	6.5	170.37	68.15	102.22	79.81	116.30	93.89	0.00	0.00	14.08	11.66									
770+00.00	TO	780+00.00	1000.00		2.2	1.14	0.83	0	4.53	6.5	1.5	0.95	3.32	0	3.81	8.08	270.00	108.00	162.00	68.52	154.44	68.52	7.56	39.48	-7.56	-39.48									
780+00.00	TO	790+00.00	1000.00		1.5	0.95	3.32	0	3.81	8.08	1.9	0.48	1.24	0	1.89	3.61	216.48	86.59	129.89	62.96	105.56	62.96	24.33	23.63	-24.33	-23.63									
790+00.00	TO	797+04.62	704.62		1.9	0.48	1.24	0	1.89	3.61	2.5	0.71	0	0.59	2.1	2.22	76.07	30.43	45.64	57.41	52.06	63.83	0.00	0.00	6.42	26.98									
797+04.62	TO	797+44.46	39.84	CR 800	2.5	0.71	0	0.59	2.1	2.22	2.35	0.63	0.03	0.31	2.49	2.84	0.00	0.00	0.00	0.00	0.00	0.00	0.00	0.00	0.00	0.00									
797+44.46	TO	800+00.00	255.54		2.35	0.63	0.03	0.31	2.49	2.84	2.13	0.4	0.42	0	1.61	2.43	24.94	9.98	14.96	21.20	19.40	25.64	0.00	0.00	4.44	11.22									
800+00.00	TO	810+00.00	1000.00		2.13	0.4	0.42	0	1.61	2.43	1.81	1.25	0.94	0	2.42	4.61	130.37	52.15	78.22	72.96	74.63	72.96	3.59	0.00	-3.59	20.81									
810+00.00	TO	820+00.00	1000.00		1.81	1.25	0.94	0	2.42	4.61	1.79	0.49	1.04	0	6.48	8.01	233.70	93.48	140.22	66.67	164.81	91.26	0.00	26.81	24.59	-26.81									
820+00.00	TO	830+00.00	1000.00		1.79	0.49	1.04	0	6.48	8.01	1.87	0.81	1.3	0	2.01	4.12	224.63	89.85	134.78	67.78	157.22	90.22	0.00	22.07	22.44	-22.07									
830+00.00	TO	840+00.00	1000.00		1.87	0.81	1.3	0	2.01	4.12	1.67	1.04	1.73	0	2.08	4.85	166.11	66.44	99.67	65.56	75.74	65.56	23.93	0.88	-23.93	-0.88									
840+00.00	TO	850+00.00	1000.00		1.67	1.04	1.73	0	2.08	4.85	2.33	0.84	0.41	0	3.38	4.63	175.56	70.22	105.34	74.07	101.11	74.07	4.23	0.00	-4.23	3.85									
850+00.00	TO	860+00.00	1000.00		2.33	0.84	0.41	0	3.38	4.63	1.5	0.61	2.27	0	2.41	5.29	183.70	73.48	110.22	70.93	107.22	70.93	3.00	2.55	-3.00	-2.55									
860+00.00	TO	870+00.00	1000.00		1.5	0.61	2.27	0	2.41	5.29	1.79	0.5	1.58	0	2.01	4.09	173.70	69.48	104.22	60.93	81.85	60.93	22.37	8.55	-22.37	-8.55									
870+00.00	TO	880+00.00	1000.00		1.79	0.5	1.58	0	2.01	4.09	1.89	0.52	1.15	0	2.07	3.74	145.00	58.00	87.00	68.15	75.56	68.15	11.44	0.00	-11.44	10.15									
880+00.00	TO	890+00.00	1000.00		1.89	0.52	1.15	0	2.07	3.74	1.9	0.42	1.38	0	1.69	3.49	133.89	53.56	80.33	70.19	69.63	70.19	10.70	0.00	-10.70	16.63									
890+00.00	TO	900+00.00	1000.00		1.9	0.42	1.38	0	1.69	3.49	2	0.65	0.92	0	2.65	4.22	142.78	57.11	85.67	72.22	80.37	72.22	5.30	0.00	-5.30	15.11									
900+00.00	TO	902+01.50	201.50	EXISTING HMA SHOULDER	2	0.65	0.92	0	2.65	4.22	2.61	0.21	2.19	0	2.67	5.07	34.67	13.87	20.80	7.46	19.85	7.46	0.95	6.41	-0.95	-6.41									
902+01.50	TO	903+00.00	98.50	EXISTING HMA SHOULDER	2.61	0.21	2.19	0	2.67	5.07	3.21	1.97	0.05	1.74	3.82	4.1	16.73	6.69	10.04	3.65	11.84	5.45	0.00	3.04	1.80	-3.04									
CHAMPAIGN COUNTY NB SUB-TOTALS =																						3651.82	289.45	557.57	-16.30	-16.72									
NORTHBOUND SUB-TOTALS =																						4376.57	336.91	596.41	-33.19	210.39									

*ASSUMED A REMOVAL OF 1" FOR VEGETATION REMOVAL

*USE A TILL DEPTH OF 4 INCHES

*IDEAL EARTH TO AGGREGATE MIX RATIO OF 60/40. MAY BE ALTERED TO MEET FIELD CONDITIONS

SCHEDULE CONTINUES ON SHEET: 17

QUANTITIES CONTINUES ON SHEET: 17, 19, AND 20

EARTHWORK CALCULATION DETAIL SHOWN ON SHEET: 17

MODEL: \\MODEL\IAMS
FILE: \IAMS - 2019\I118RS-3-119RS-4.D5\CHAMPAIGN\I118RS-3-119RS-4.D5-RT-Schedule.dgn

USER NAME = PiersonJ	DESIGNED -	REVISED -	STATE OF ILLINOIS DEPARTMENT OF TRANSPORTATION				SCHEDULE OF QUANTITIES				F.A.P. RTE. 836	SECTION **	COUNTY *	TOTAL SHEETS 214	SHEET NO. 18
PLOT SCALE = 40.0000 ' / in.	CHECKED -	REVISED -									SCALE:	SHEET 2 OF 19 SHEETS	STA.	TO STA.	ILLINOIS FED. AID PROJECT
PLOT DATE = 3/22/2019	DATE -	REVISED -	**118RS-3,119RS-4,D5 HSIP 2019-1 CHAMPAIGN & VERMILION												

SCHEDULE OF QUANTITIES

NB SEEDING SCHEDULE																			
STA	TO	STA	LENGTH FT	OMISSION REASON	START RIGHT LENGTH FT	END RIGHT LENGTH FT	RIGHT AREA SQ FT	HSIP		HSIP		HSIP		HSIP		HSIP			
								CHAMPAIGN	VERMILION	CHAMPAIGN	VERMILION	CHAMPAIGN	VERMILION	CHAMPAIGN	VERMILION	CHAMPAIGN	VERMILION		
								25000210		25000400		25000500		25000600		25100115		28000250	
							SEEDING CLASS 2A	NITROGEN FERTILIZER NUTRIENT	PHOSPHORUS FERTILIZER NUTRIENT	POTASSIUM FERTILIZER NUTRIENT	MULCH METHOD 2	TEMPORARY EROSION CONTROL SEEDING							
							ACRE	POUND	POUND	POUND	ACRE	POUND							
321+00.00	TO	330+00.00	900.00		9.05	7.28	7,348.50		0.17	15.30		15.30		0.17	68.00				
330+00.00	TO	340+00.00	1000.00		7.28	6.22	6,750.00		0.16	14.40		14.40		0.16	64.00				
340+00.00	TO	350+00.00	1000.00		6.22	6.4	6,310.00		0.15	13.50		13.50		0.15	60.00				
350+00.00	TO	360+00.00	1000.00		6.4	6.14	6,270.00		0.15	13.50		13.50		0.15	60.00				
360+00.00	TO	370+00.00	1000.00		6.14	6.97	6,555.00		0.16	14.40		14.40		0.16	64.00				
370+00.00	TO	373+56.52	356.52		6.97	6.67	2,431.47		0.06	5.40		5.40		0.06	24.00				
373+56.52	TO	373+90.27	33.75	E 200 N RD	6.67	7.22	234.39		0.00	0.00		0.00		0.00	0.00				
373+90.27	TO	380+00.00	609.73		7.22	11.68	5,761.95		0.14	12.60		12.60		0.14	56.00				
380+00.00	TO	390+00.00	1000.00		11.68	6.25	8,965.00		0.21	18.90		18.90		0.21	84.00				
390+00.00	TO	405+00.00	1500.00		6.25	5.4	8,737.50		0.21	18.90		18.90		0.21	84.00				
405+00.00	TO	410+00.00	500.00		5.4	5.9	2,825.00		0.07	6.30		6.30		0.07	28.00				
410+00.00	TO	420+00.00	1000.00		5.9	2	3,950.00		0.10	9.00		9.00		0.10	40.00				
420+00.00	TO	420+37.80	37.80		2	2	75.60		0.01	0.90		0.90		0.01	4.00				
420+37.80	TO	423+24.54	286.74	ALLERTON	2	2	573.48		0.00	0.00		0.00		0.00	0.00				
423+24.54	TO	427+41.88	417.34		2	2	834.68	0.02	1.80		1.80		0.02	8.00					
427+41.88	TO	428+41.09	99.21	E YATES ST	2	12.05	696.95	0.00	0.00		0.00		0.00	0.00					
428+41.09	TO	430+00.00	158.91		12.05	7.5	1,553.35	0.04	3.60		3.60		0.04	16.00					
430+00.00	TO	440+00.00	1000.00		7.5	8.35	7,925.00	0.19	17.10		17.10		0.19	76.00					
440+00.00	TO	450+00.00	1000.00		8.35	6.96	7,655.00	0.18	16.20		16.20		0.18	72.00					
450+00.00	TO	460+00.00	1000.00		6.96	7.58	7,270.00	0.17	15.30		15.30		0.17	68.00					
460+00.00	TO	467+98.05	798.05		7.58	12.14	7,868.77	0.19	17.10		17.10		0.19	76.00					
467+98.05	TO	468+49.71	51.66	SMALL ROAD	12.14	2	365.24	0.01	0.90		0.90		0.01	4.00					
468+49.71	TO	470+00.00	150.29		2	2	300.58	0.01	0.90		0.90		0.01	4.00					
470+00.00	TO	480+00.00	1000.00		2	11.55	6,775.00	0.16	14.40		14.40		0.16	64.00					
480+00.00	TO	490+00.00	1000.00		11.55	14.94	13,245.00	0.31	27.90		27.90		0.31	124.00					
490+00.00	TO	500+00.00	1000.00		14.94	10.06	12,500.00	0.29	26.10		26.10		0.29	116.00					
500+00.00	TO	510+00.00	1000.00		10.06	6.89	8,475.00	0.20	18.00		18.00		0.20	80.00					
510+00.00	TO	520+00.00	1000.00		6.89	8.62	7,755.00	0.18	16.20		16.20		0.18	72.00					
520+00.00	TO	530+00.00	1000.00		8.62	7.84	8,230.00	0.19	17.10		17.10		0.19	76.00					
530+00.00	TO	531+78.49	178.49		7.84	8.49	1,457.37	0.04	3.60		3.60		0.04	16.00					
531+78.49	TO	532+12.14	33.65	CR 300	8.49	8.35	283.33	0.00	0.00		0.00		0.00	0.00					
532+12.14	TO	540+00.00	787.86		8.35	7.59	6,279.24	0.15	13.50		13.50		0.15	60.00					
540+00.00	TO	550+00.00	1000.00		7.59	5.72	6,655.00	0.16	14.40		14.40		0.16	64.00					
550+00.00	TO	560+00.00	1000.00		5.72	9.03	7,375.00	0.17	15.30		15.30		0.17	68.00					
560+00.00	TO	570+00.00	1000.00		9.03	10.62	9,825.00	0.23	20.70		20.70		0.23	92.00					
570+00.00	TO	571+38.49	138.49		10.62	14.29	1,724.89	0.04	3.60		3.60		0.04	16.00					
571+38.49	TO	571+72.59	34.10	CR 375	14.29	9.3	402.21	0.00	0.00		0.00		0.00	0.00					
571+72.59	TO	580+00.00	827.41		9.3	6.14	6,387.61	0.15	13.50		13.50		0.15	60.00					
580+00.00	TO	590+00.00	1000.00		6.14	5.45	5,795.00	0.14	12.60		12.60		0.14	56.00					
590+00.00	TO	600+00.00	1000.00		5.45	11.57	8,510.00	0.20	18.00		18.00		0.20	80.00					
600+00.00	TO	610+00.00	1000.00		11.57	11.76	11,665.00	0.27	24.30		24.30		0.27	108.00					
610+00.00	TO	620+00.00	1000.00		11.76	8.76	10,260.00	0.24	21.60		21.60		0.24	96.00					
620+00.00	TO	630+00.00	1000.00		8.76	5.88	7,320.00	0.17	15.30		15.30		0.17	68.00					
630+00.00	TO	637+63.10	763.10		5.88	9.57	5,894.95	0.14	12.60		12.60		0.14	56.00					
637+63.10	TO	638+02.11	39.01	CR 500	9.57	9.01	362.40	0.00	0.00		0.00		0.00	0.00					
638+02.11	TO	640+00.00	197.89		9.01	9.76	1,857.20	0.05	4.50		4.50		0.05	20.00					
640+00.00	TO	650+00.00	1000.00		9.76	9.24	9,500.00	0.22	19.80		19.80		0.22	88.00					
650+00.00	TO	660+00.00	1000.00		9.24	12.92	11,080.00	0.26	23.40		23.40		0.26	104.00					
660+00.00	TO	664+23.95	423.95		12.92	11.72	5,223.06	0.12	10.80		10.80		0.12	48.00					
664+23.95	TO	664+99.19	75.24	SN 010-0236	11.72	24.79	1,373.51	0.00	0.00		0.00		0.00	0.00					
664+99.19	TO	670+00.00	500.81		24.79	27.29	13,041.09	0.30	27.00		27.00		0.30	120.00					
670+00.00	TO	680+00.00	1000.00		27.29	28.88	28,085.00	0.65	58.50		58.50		0.65	260.00					
680+00.00	TO	686+75.29	675.29		28.88	43.43	24,415.11	0.57	51.30		51.30		0.57	228.00					
686+75.29	TO	690+77.85	402.56	SN 010-0284	43.43	21.12	12,992.62	0.00	0.00		0.00		0.00	0.00					
690+77.85	TO	700+00.00	922.15		21.12	14.5	16,423.49	0.38	34.20		34.20		0.38	152.00					
700+00.00	TO	710+00.00	1000.00		14.5	8.7	11,600.00	0.27	24.30		24.30		0.27	108.00					
710+00.00	TO	720+00.00	1000.00		8.7	8.5	8,600.00	0.20	18.00		18.00		0.20	80.00					
720+00.00	TO	729+30.49	930.49		8.5	13.5	10,235.39	0.24	21.60		21.60		0.24	96.00					
729+30.49	TO	729+66.49	36.00	SN 010-0269	13.5	13.8	491.40	0.00	0.00		0.00		0.00	0.00					
SHEET BREAK SUB-TOTALS =								7.50	1.59	675.00	143.10	675.00	143.10	675.00	143.10	7.50	1.59	3000.00	636.00

SCHEDULE CONTINUES ON SHEET: 22
 QUANTITIES CONTINUES ON SHEET: 22 AND 23

MODEL: \\MOBILE\MFIS... \FILES\Amfisc... \PROJECTS\0570D5\CAD\DATA\Design\0570D5\ps-hr-Schedule.dgn

USER NAME = Piersontj	DESIGNED -	REVISED -	STATE OF ILLINOIS DEPARTMENT OF TRANSPORTATION	SCHEDULE OF QUANTITIES	F.A.P. RTE. 836	SECTION **	COUNTY *	TOTAL SHEETS 214	SHEET NO. 21
PLOT SCALE = 40,0000 ' / in.	CHECKED -	REVISED -			SCALE:	SHEET 5 OF 19 SHEETS	STA.	TO STA.	CONTRACT NO. 70D56
PLOT DATE = 3/22/2019	DATE -	REVISED -	ILLINOIS FED. AID PROJECT **118RS-3,119RS-4,D5 HSIP 2019-1 *CHAMPAIGN & VERMILION						

SCHEDULE OF QUANTITIES

SB SEEDING SCHEDULE																			
STA	TO	STA	LENGTH FT	OMISSION REASON	START LEFT LENGTH FT	END LEFT LENGTH FT	LEFT AREA SQ FT	HSIP		HSIP		HSIP		HSIP		HSIP			
								CHAMPAIGN	VERMILION	CHAMPAIGN	VERMILION	CHAMPAIGN	VERMILION	CHAMPAIGN	VERMILION	CHAMPAIGN	VERMILION	CHAMPAIGN	VERMILION
								25000210		25000400		25000500		25000600		25100115		28000250	
								SEEDING CLASS 2A	NITROGEN FERTILIZER NUTRIENT	PHOSPHORUS FERTILIZER NUTRIENT	POTASSIUM FERTILIZER NUTRIENT	MULCH METHOD 2	TEMPORARY EROSION CONTROL SEEDING						
								ACRE	POUND	POUND	POUND	ACRE	POUND						
500+00.00	TO	510+00.00	1000.00		8.6	7.3	7,950.00	0.19	17.10	17.10	17.10	17.10	0.19	76.00					
510+00.00	TO	520+00.00	1000.00		7.3	7.59	7,445.00	0.18	16.20	16.20	16.20	16.20	0.18	72.00					
520+00.00	TO	530+00.00	1000.00		7.59	6.58	7,085.00	0.17	15.30	15.30	15.30	15.30	0.17	68.00					
530+00.00	TO	531+73.61	173.61		6.58	8.17	1,280.37	0.03	2.70	2.70	2.70	2.70	0.03	12.00					
531+73.61	TO	532+15.59	41.98	CR 300	8.17	8.51	350.11	0.00	0.00	0.00	0.00	0.00	0.00	0.00					
532+15.59	TO	540+00.00	784.41		8.51	5.74	5,588.92	0.13	11.70	11.70	11.70	11.70	0.13	52.00					
540+00.00	TO	550+00.00	1000.00		5.74	6.18	5,960.00	0.14	12.60	12.60	12.60	12.60	0.14	56.00					
550+00.00	TO	560+00.00	1000.00		6.18	10.06	8,120.00	0.19	17.10	17.10	17.10	17.10	0.19	76.00					
560+00.00	TO	570+00.00	1000.00		10.06	11.81	10,935.00	0.26	23.40	23.40	23.40	23.40	0.26	104.00					
570+00.00	TO	580+00.00	1000.00		11.81	5.24	8,525.00	0.20	18.00	18.00	18.00	18.00	0.20	80.00					
580+00.00	TO	584+61.05	461.05		5.24	5.74	2,531.16	0.06	5.40	5.40	5.40	5.40	0.06	24.00					
584+61.05	TO	585+14.47	53.42	CR 400	5.74	7.08	342.42	0.00	0.00	0.00	0.00	0.00	0.00	0.00					
585+14.47	TO	590+00.00	485.53		7.08	6.41	3,274.90	0.08	7.20	7.20	7.20	7.20	0.08	32.00					
590+00.00	TO	600+00.00	1000.00		6.41	7.49	6,950.00	0.16	14.40	14.40	14.40	14.40	0.16	64.00					
600+00.00	TO	610+00.00	1000.00		7.49	33.39	20,440.00	0.47	42.30	42.30	42.30	42.30	0.47	188.00					
610+00.00	TO	620+00.00	1000.00		33.39	8.16	20,775.00	0.48	43.20	43.20	43.20	43.20	0.48	192.00					
620+00.00	TO	630+00.00	1000.00		8.16	10.8	9,480.00	0.22	19.80	19.80	19.80	19.80	0.22	88.00					
630+00.00	TO	637+54.63	754.63		10.8	8.29	7,202.94	0.17	15.30	15.30	15.30	15.30	0.17	68.00					
637+54.63	TO	637+91.83	37.20	CR 500	8.29	8.32	308.95	0.00	0.00	0.00	0.00	0.00	0.00	0.00					
637+91.83	TO	640+00.00	208.17		8.32	8.5	1,750.71	0.05	4.50	4.50	4.50	4.50	0.05	20.00					
640+00.00	TO	650+00.00	1000.00		8.5	9.86	9,180.00	0.22	19.80	19.80	19.80	19.80	0.22	88.00					
650+00.00	TO	660+00.00	1000.00		9.86	15.24	12,550.00	0.29	26.10	26.10	26.10	26.10	0.29	116.00					
660+00.00	TO	664+09.01	409.01		15.24	17.67	6,730.26	0.16	14.40	14.40	14.40	14.40	0.16	64.00					
664+09.01	TO	664+84.36	75.35	SN 010-0236	17.67	27.81	1,713.46	0.00	0.00	0.00	0.00	0.00	0.00	0.00					
664+84.36	TO	670+00.00	515.64		27.81	28.08	14,409.56	0.34	30.60	30.60	30.60	30.60	0.34	136.00					
670+00.00	TO	680+00.00	1000.00		28.08	30.97	29,525.00	0.68	61.20	61.20	61.20	61.20	0.68	272.00					
680+00.00	TO	686+25.38	625.38		30.97	43.21	23,195.34	0.54	48.60	48.60	48.60	48.60	0.54	216.00					
686+25.38	TO	691+49.77	524.39	SN 010-0284	43.21	40.25	21,882.79	0.00	0.00	0.00	0.00	0.00	0.00	0.00					
691+49.77	TO	700+00.00	850.23		40.25	32.97	31,126.92	0.72	64.80	64.80	64.80	64.80	0.72	288.00					
700+00.00	TO	710+00.00	1000.00		32.97	23.13	28,050.00	0.65	58.50	58.50	58.50	58.50	0.65	260.00					
710+00.00	TO	720+00.00	1000.00		23.13	21.09	22,110.00	0.51	45.90	45.90	45.90	45.90	0.51	204.00					
720+00.00	TO	729+30.49	930.49		21.09	15.29	16,925.61	0.39	35.10	35.10	35.10	35.10	0.39	156.00					
729+30.49	TO	729+66.49	36.00	SN 010-0269	15.29	15.23	549.36	0.00	0.00	0.00	0.00	0.00	0.00	0.00					
729+66.49	TO	730+00.00	33.51		15.23	14.6	499.80	0.02	1.80	1.80	1.80	1.80	0.02	8.00					
730+00.00	TO	740+00.00	1000.00		14.6	7.45	11,025.00	0.26	23.40	23.40	23.40	23.40	0.26	104.00					
740+00.00	TO	744+03.53	403.53		7.45	7.39	2,994.19	0.07	6.30	6.30	6.30	6.30	0.07	28.00					
744+03.53	TO	744+47.57	44.04	CR 700	7.39	8.67	353.64	0.00	0.00	0.00	0.00	0.00	0.00	0.00					
744+47.57	TO	750+00.00	552.43		8.67	6.99	4,325.53	0.10	9.00	9.00	9.00	9.00	0.10	40.00					
750+00.00	TO	760+00.00	1000.00		6.99	9.28	8,135.00	0.19	17.10	17.10	17.10	17.10	0.19	76.00					
760+00.00	TO	770+00.00	1000.00		9.28	11.13	10,205.00	0.24	21.60	21.60	21.60	21.60	0.24	96.00					
770+00.00	TO	780+00.00	1000.00		11.13	12.82	11,975.00	0.28	25.20	25.20	25.20	25.20	0.28	112.00					
780+00.00	TO	790+00.00	1000.00		12.82	6.07	9,445.00	0.22	19.80	19.80	19.80	19.80	0.22	88.00					
790+00.00	TO	797+08.58	708.58		6.07	7.34	4,751.03	0.11	9.90	9.90	9.90	9.90	0.11	44.00					
797+08.58	TO	797+46.83	38.25	CR 800	7.34	8.4	301.03	0.00	0.00	0.00	0.00	0.00	0.00	0.00					
797+46.83	TO	800+00.00	253.17		8.4	5.85	1,803.84	0.05	4.50	4.50	4.50	4.50	0.05	20.00					
800+00.00	TO	810+00.00	1000.00		5.85	8.31	7,080.00	0.17	15.30	15.30	15.30	15.30	0.17	68.00					
810+00.00	TO	820+00.00	1000.00		8.31	6.67	7,490.00	0.18	16.20	16.20	16.20	16.20	0.18	72.00					
820+00.00	TO	830+00.00	1000.00		6.67	7.07	6,870.00	0.16	14.40	14.40	14.40	14.40	0.16	64.00					
830+00.00	TO	840+00.00	1000.00		7.07	8.57	7,820.00	0.18	16.20	16.20	16.20	16.20	0.18	72.00					
840+00.00	TO	849+96.81	996.81		8.57	6.68	7,600.68	0.18	16.20	16.20	16.20	16.20	0.18	72.00					
849+96.81	TO	850+40.30	43.49	CR 900	6.68	9.02	341.40	0.00	0.00	0.00	0.00	0.00	0.00	0.00					
850+40.30	TO	860+00.00	959.70		9.02	10.33	9,285.10	0.22	19.80	19.80	19.80	19.80	0.22	88.00					
860+00.00	TO	870+00.00	1000.00		10.33	9.66	9,995.00	0.23	20.70	20.70	20.70	20.70	0.23	92.00					
870+00.00	TO	880+00.00	1000.00		9.66	8	8,830.00	0.21	18.90	18.90	18.90	18.90	0.21	84.00					
880+00.00	TO	890+00.00	1000.00		8	8.15	8,075.00	0.19	17.10	17.10	17.10	17.10	0.19	76.00					
890+00.00	TO	900+00.00	1000.00		8.15	12.46	10,305.00	0.24	21.60	21.60	21.60	21.60	0.24	96.00					
900+00.00	TO	902+02.32	202.32		12.46	13.01	2,576.55	0.06	5.40	5.40	5.40	5.40	0.06	24.00					
902+02.32	TO	903+82.91	180.59		13.01	2	1,355.33	0.04	3.60	3.60	3.60	3.60	0.04	16.00					
SOUTHBOUND SUB-TOTALS =								12.74	1.65	1,146.60	148.50	1,146.60	148.50	1,146.60	148.50	12.74	1.65	5,096.0	660.0
SUB-TOTALS =								23.55	3.24	2,119.50	291.60	2,119.50	291.60	2,119.50	291.60	23.55	3.24	9,420.0	1,296.0
ROUNDED SUB-TOTALS =								23.75	3.25	2,137.50	292.50	2,137.50	292.50	2,137.50	292.50	23.75	3.25	9,500.0	1,300.0
TOTALS =								27.00		2,430.00		2,430.00		2,430.00		27.00		10,800.00	

SCHEDULE CONTINUES ON SHEET: 22
QUANTITIES CONTINUES ON SHEET: 21 AND 22

SCHEDULE OF QUANTITIES

TEMPORARY DITCH CHECKS SCHEDULE			
SIDE	STA	HSIP	
		CHAMPAIGN	VERMILION
		28000305	
		TEMPORARY DITCH CHECK	
		FOOT	
LT	381+25.00		4.0
LT	380+40.00		4.0
RT	381+25.00		4.0
RT	380+20.00		4.0
RT	423+70.00	4.0	
LT	423+25.00	4.0	
LT	423+50.00	4.0	
RT	440+00.00	4.0	
RT	440+40.00	4.0	
LT	440+05.00	4.0	
LT	440+35.00	4.0	
RT	479+85.00	4.0	
LT	479+85.00	4.0	
RT	491+25.00	4.0	
RT	491+50.00	4.0	
LT	491+25.00	4.0	
RT	491+50.00	4.0	
RT	566+50.00	4.0	
RT	567+00.00	4.0	
LT	566+50.00	4.0	
LT	567+00.00	4.0	
RT	600+75.00	4.0	
RT	601+75.00	4.0	
LT	600+85.00	4.0	
LT	601+85.00	4.0	
RT	664+10.00	4.0	
RT	665+15.00	4.0	
LT	664+00.00	4.0	
LT	665+15.00	4.0	
RT	687+75.00	4.0	
RT	689+25.00	4.0	
LT	688+00.00	4.0	
LT	689+50.00	4.0	
LT	690+50.00	4.0	
LT	692+00.00	4.0	
LT	701+15.00	4.0	
LT	702+15.00	4.0	
RT	729+15.00	4.0	
RT	729+75.00	4.0	
LT	729+20.00	4.0	
LT	729+80.00	4.0	
RT	752+50.00	4.0	
RT	753+25.00	4.0	
RT	754+00.00	4.0	
LT	752+50.00	4.0	
LT	753+25.00	4.0	
LT	754+00.00	4.0	
RT	773+75.00	4.0	
RT	774+15.00	4.0	
LT	773+75.00	4.0	
LT	774+15.00	4.0	
RT	806+00.00	4.0	
RT	806+40.00	4.0	
LT	806+00.00	4.0	
LT	806+40.00	4.0	
RT	903+90.00	4.0	
LT	903+95.00	4.0	
SUB-TOTALS =		212	16
TOTALS =		228.0	

MAINLINE INLAY SCHEDULE															
STA	TO	STA	LENGTH FOOT	BEGIN LANE WIDTH FOOT	END LANE WIDTH FOOT	AVG LANE WIDTH FOOT	LANE AREA SQ YD	SMART		SMART		SMART		SMART	
								CHAMPAIGN	VERMILION	CHAMPAIGN	VERMILION	CHAMPAIGN	VERMILION	CHAMPAIGN	VERMILION
								40600290		40603310		44000155		Z0033700	
								BIT MATL (TACK COAT)	HMA SURF CSE MIX C, N50	HMA SURFACE REMOVAL 1.5 INCH	LONGITUDINAL JOINT SEALANT				
								POUND	TON		SQ YD		FOOT		
321+00.00	TO	421+77.05	10,077.05	26.0	26.0	26.0	29,111.5		13,100.2		2,445.4		29,111.5		10,077.1
421+77.05	TO	664+16.11	24,239.06	26.0	26.0	26.0	70,024.0	31,510.8		5,882.0		70,024.0		24,239.1	
664+16.11	TO	664+91.60	75.49	0.0	0.0	0.0	0.0	0.0		0.0		0.0		0.0	
664+91.60	TO	686+75.29	2,183.69	26.0	26.0	26.0	6,308.4	2,838.8		529.9		6,308.4		2,183.7	
686+75.29	TO	690+77.80	402.51	0.0	0.0	0.0	0.0	0.0		0.0		0.0		0.0	
690+77.80	TO	728+64.37	3,786.57	26.0	26.0	26.0	10,939.0	4,922.6		918.9		10,939.0		3,786.6	
729+30.49	TO	729+66.49	36.00	0.0	0.0	0.0	0.0	0.0		0.0		0.0		0.0	
729+66.49	TO	903+82.91	17,416.42	26.0	26.0	26.0	50,314.1	22,641.3		4,226.4		50,314.1		17,416.4	
SUB-TOTALS =								61,913.5	13,100.2	11,557.2	2,445.4	137,585.5	29,111.5	47,625.7	10,077.1
ROUNDED SUB-TOTALS =								61,914.0	13,101.0	11,558.0	2,446.0	137,586.0	29,112.0	47,626.0	10,078.0
TOTALS =								75,015.0		14,004.0		166,698.0		57,704.0	

* 729+30.49 TO 729+66.49 QUANTITIES SHOWN IN S.N. 010-0269 DETAIL
 40600290 CONTINUES ON SHEET: 25, 28, AND 29
 40603310 CONTINUES ON SHEET: 25, 28, AND 29
 44000155 CONTINUES ON SHEET: 25, 28, AND 29

PCC SHOULDER REMOVAL SCHEDULE							
SIDE	STA	TO	STA	LENGTH FOOT	SHOULDER WIDTH FOOT	SHOULDER AREA SQ YD	HSIP
							44004250
							CHAMPAIGN PAVED SHOULDER REMOVAL
				SQ YD			
RT	686+26.78	TO	686+75.09	48.31	4	22	22
LT	686+25.38	TO	686+75.66	50.28	3	17	17
TOTALS =							39

DITCH CLEANING SCHEDULE				
STA	TO	STA	LENGTH FOOT	HSIP
				CHAMPAIGN
				21400100
				GRADING & SHAPING DITCH FOOT
LT	690+14.13	TO	690+66.66	52.5
LT	691+75.68	TO	692+43.88	68.2
LT	700+07.42	TO	701+22.45	115.0
LT	702+04.96	TO	704+15.69	210.7
TOTALS =				446.5
ROUNDED TOTALS =				447.0

*SEEDING INCLUDED IN 21400100

BOX CULVERT EARTHWORK SCHEDULE				
SIDE	STA	STRUCTURE NUMBER	HSIP	
			CHAMPAIGN	VERMILION
			20400800	
			FURNISHED EXCAVATION	
			CU YD	
LT	691+21.33	S.N. 010-8176	466.36	
LT	701+63.97	S.N. 010-8177	243.06	
SUB-TOTALS =			709.42	
ROUNDED TOTALS =			710.00	

20400800 CONTINUES ON SHEET: 20

MODEL: \\MODEL\MHMS
 FILE: \\MAILS_P\pub\mcomada\at\links\gov\PIWDOT\Documents\DOT_Offices\Dist\ct_5\Projects\0570D56\CADD\Drawn\Design\0570D56-ht-Schedule.dgn

USER NAME = PiersonTJ	DESIGNED -	REVISED -	STATE OF ILLINOIS DEPARTMENT OF TRANSPORTATION	SCHEDULE OF QUANTITIES			F.A.P. RTE.	SECTION	COUNTY	TOTAL SHEETS	SHEET NO.
PLOT SCALE = 40.0000 ' / in.	CHECKED -	REVISED -		836	**	-	214	24			
PLOT DATE = 3/22/2019	DATE -	REVISED -		SCALE: SHEET 8 OF 19 SHEETS STA. TO STA.			ILLINOIS FED. AID PROJECT		CONTRACT NO. 70D56		
							**118RS-3,119RS-4,D5 HSIP 2019-1		*CHAMPAIGN & VERMILION		

SCHEDULE OF QUANTITIES

INCIDENTAL RESURFACING SCHEDULE																											
SID	STATION	DESCRIPTION	REMOVAL AREA SQ FT	RESURFACE AREA SQ FT	AREA SQ YD	AVERAGE THICKNESS INCHES	HSIP	SMART	SMART	SMART	SMART	HSIP	HSIP	SMART	SMART	HSIP	HSIP	SMART	HSIP	HSIP	SAFETY	SAFETY	HSIP	HSIP			
							CHAM	CHAM	CHAM	CHAM	VERM	CHAM	VERM	CHAM	VERM	CHAM	VERM	CHAM	VERM	CHAM	CHAM	VERM	CHAM	CHAM	CHAM	CHAM	VERM
							35100300 AGG BASE CSE TY A 4 IN	40600290 BIT MATL (TACK COAT)	40603310 HMA SURF CSE MIX C, N50 1.5 INCH	40800029 BIT MATL (TACK COAT)	40800050 INCIDENTAL HMA SURFACING					44000100 PAVEMENT REMOVAL			44000155 HMA SURF. REM. 1.5 INCH	40200800 AGG SURF. CSE TY B	48101200 AGG SHLDR TY B, 6 IN	X4400196 HMA SURF REMOVAL SPECIAL					
							SQ YD	POUND	TON	POUND					SQ YD			SQ YD	TON	TON	SQ YD						
L	331+12.18	FE 72	95.1	165.3	18.4	1.50						8.3				1.5			10.6						18.4		
L	342+91.18	PE 28	211.5	216.3	24.0	1.50						10.8				2.0			23.5						24.0		
R	345+13.96	FE 69	84.9	134.7	15.0	1.50						6.8				1.3			9.4						15.0		
L	354+85.32	PE 27	183.9	152.9	17.0	1.50						7.7				1.4			20.4						17.0		
L	357+06.50	PE 26	110.7	198.7	22.1	1.50						9.9				1.9			12.3						22.1		
L	372+08.60	FE 66	103.6	181.7	20.2	1.50						9.1				1.7			11.5						20.2		
L	373+57.33	FE 65 + CR 100N		1361.1	151.2	1.50						68.0				12.7			0.0						151.2		
R	408+76.71	PE 24	83.1	121.3	13.5	1.50						6.1				1.1			9.2						13.5		
R	419+19.38	PE 23	240.1	503.8	56.0	1.50						25.2				4.7			26.7						56.0		
R	486+40.27	PE 21	186.9	336.5	37.4	1.50						16.8				3.1			20.8						37.4		
R	506+62.40	PE 18	90.8	142.4	15.8	1.50						7.1				1.3			10.1						15.8		
R	514+65.26	PE 17	83.0	120.5	13.4	1.50						6.0				1.1			9.2						13.4		
L	519+53.75	PE 16	100.4	123.4	13.7	1.50						6.2				1.2			11.2						13.7		
L	594+80.56	PE 15	202.9	227.2	25.2	1.50						11.3				2.1			22.5						25.2		
R	595+49.05	PE 14	79.1	139.5	15.5	1.50						7.0				1.3			8.8						15.5		
R	646+25.56	PE 12	194.2	134.7	15.0	1.50						6.8				1.3			21.6						15.0		
L	652+80.12	PE 11	111.0	303.2	33.7	1.50						15.2				2.8			12.3						33.7		
L	678+92.22	PE 10	122.5	198.1	22.0	1.50						9.9				1.8			13.6						22.0		
R	705+51.02	PE 9	109.2	234.3	26.0	1.50						11.7				2.2			12.1						26.0		
L	768+18.35	PE 7	139.0	454.1	50.5	1.50						22.7				4.2			15.4						50.5		
R	848+19.42	PE 5	104.5	168.0	18.7	1.50						8.4				1.6			11.6						18.7		
L	848+42.49	PE 4	181.2	193.1	21.5	1.50						9.7				1.8			20.1						21.5		
L	858+49.30	PE 3	233.2	219.6	24.4	1.50						11.0				2.0			25.9						24.4		
R	903+32.92	FE 2	109.9	893.2	99.2	1.50						44.6				8.3			12.2						99.2		
R	373+71.49	E 200N RD	345.1	345.1	38.3	1.50						17.2				3.2								38.3			
R	421+77.05	CR 2800E	1968.8	1968.8	218.8	1.50				98.5				18.4								218.8					
R	428+18.72	E YATES ST	7157.2	7157.2	795.2	1.50		357.80	66.80										795.2								
R	467+01.77	200N	634.9															70.5									
R	478+65.04	200N	477.6															53.1									
L	478+40.00	CR 2700E + BROADLANDS	4142.6	4142.6	460.3	1.50				207.1				38.7								460.3					
R	531+93.95	CR 300N	348.8	348.8	38.8	1.50				17.5				3.3								38.8					
L	531+94.36	CR 300N	425.0	425.0	47.2	1.50				21.2				4.0								47.2					
R	571+57.59	CR 375N	340.3	340.3	37.8	1.50				17.0				3.2								37.8					
L	584+86.30	CR 400N	543.0	543.0	60.3	1.50				27.1				5.1								60.3					
R	637+84.00	CR 500N	402.9	402.9	44.8	1.50				20.2				3.8								44.8					
L	637+72.70	CR 500N	393.8	393.8	43.8	1.50				19.7				3.7								43.8					
L	691+21.33	CR 600N	2201.9	3397.7	377.5	4.00		377.50								84.6			244.7				15.33				
L	701+63.97	FE 24		926.3	102.9	6.00																					
R	744+25.74	CR 700N	498.8	498.8	55.4	1.50				24.9				4.7								55.4					
L	744+24.29	CR 700N	444.5	444.5	49.4	1.50				22.2				4.1								49.4					
R	797+24.12	CR 800	410.1	410.1	45.6	1.50				20.5				3.8								45.6					
L	797+23.41	CR 800	390.1	390.1	43.3	1.50				19.5				3.6								43.3					
L	850+15.73	CR 900N	434.2	434.2	48.2	1.50				21.7				4.0								48.2					
SUB-TOTALS =							377.5	357.8	66.8	537.1	17.2	194.4	151.9	100.3	3.2	120.8	28.3	123.6	472.1	123.6	795.2	30.9	15.3	1193.7	38.3	432.0	337.4
ROUNDED SUB-TOTALS =							378.0	358.0	67.0	538.0	18.0	195.0	152.0	101.0	4.0	121.0	29.0	124.0	473.0	124.0	796.0	31.0	16.0	1194.0	39.0	432.0	338.0
TOTALS =							378.0	358.0	67.0		903.0					255.0				721.0		796.0	31.0	16.0		2003.0	

40600290 CONTINUES ON SHEET: 24, 28, AND 29
 40603310 CONTINUES ON SHEET: 24, 28, AND 29
 44000155 CONTINUES ON SHEET: 24, 28, AND 29

USER NAME = PiersontJ DESIGNED - DRAWN -	REVISED - REVISED - REVISED - REVISED -	STATE OF ILLINOIS DEPARTMENT OF TRANSPORTATION	SCHEDULE OF QUANTITIES	F.A.P. RTE. 836 SECTION ** COUNTY - TOTAL SHEETS 214 SHEET NO. 25 CONTRACT NO. 70D56
PLOT SCALE = 40.0000' / in. CHECKED - DATE -		SCALE: SHEET 9 OF 19 SHEETS STA. TO STA. ILLINOIS FED. AID PROJECT		

MODEL: 4\MODEL\MATFS
 FILE: MATFS_Plot\Illinois_70D56\CADData\Design\70D56-Sch-Schedule.dgn

SCHEDULE OF QUANTITIES

CLASS D PATCHING SCHEDULE									
DIRECTION	STA	LENGTH FOOT	WIDTH FOOT	THICKNESS IN	SMART	SMART	SMART	SMART	
					VERMILION	CHAMPAIGN	VERMILION	CHAMPAIGN	
					44201777	44201839	44201843	44201845	
					CLASS D PATCH TYPE II, 11"	CLASS D PATCH TYPE II, 16"	CLASS D PATCH TYPE III, 16"	CLASS D PATCH TYPE IV, 16"	
					SQ YD	SQ YD	SQ YD	SQ YD	
NB	321+17.00	6	13	16			8.7		
SB	321+17.00	6	13	16			8.7		
NB	330+92.00	10	13	16			14.5		
SB	330+92.00	10	13	16			14.5		
NB	380+58.00	10.00	13.00	11.00	14.5				
SB	380+58.00	10.00	13.00	11.00	14.5				
NB	381+36.00	6	13	16			8.7		
SB	381+36.00	6	13	16			8.7		
NB	387+08.00	6	13	16			8.7		
SB	388+18.00	6	13	16			8.7		
NB	411+87.00	10	13	16			14.5		
SB	411+87.00	10	13	16			14.5		
SB	441+63.00	6	13	16		8.7			
NB	441+63.00	12	13	16			17.4		
NB	524+49.00	8	13	16		11.6			
SB	525+71.00	10	13	16		14.5			
NB	541+41.00	10	13	16		14.5			
SB	541+41.00	10	13	16		14.5			
NB	544+65.00	6	13	16		8.7			
SB	544+65.00	6	13	16		8.7			
NB	545+37.00	6	13	16		8.7			
NB	549+95.00	10	13	16		14.5			
SB	549+95.00	10	13	16		14.5			
NB	557+62.00	10	13	16		14.5			
SB	557+62.00	10	13	16		14.5			
NB	558+23.00	10	13	16		14.5			
SB	558+23.00	10	13	16		14.5			
NB	559+02.00	6	13	16		8.7			
SCHEDULE BREAK SUB-TOTALS =					29.0	185.6	110.2	17.4	0.0

CLASS D PATCHING SCHEDULE									
DIRECTION	STA	LENGTH FOOT	WIDTH FOOT	THICKNESS IN	SMART	SMART	SMART	SMART	
					VERMILION	CHAMPAIGN	VERMILION	CHAMPAIGN	
					44201777	44201839	44201843	44201845	
					CLASS D PATCH TYPE II, 11"	CLASS D PATCH TYPE II, 16"	CLASS D PATCH TYPE III, 16"	CLASS D PATCH TYPE IV, 16"	
					SQ YD	SQ YD	SQ YD	SQ YD	
SB	559+02.00	6	13	16		8.7			
SB	603+44.00	10	13	16		14.5			
NB	606+27.00	25	13	16				36.2	
NB	606+74.00	6	13	16		8.7			
NB	631+89.00	30	13	16				43.4	
SB	631+89.00	30	13	16				43.4	
NB	638+43.00	10	13	16		14.5			
SB	638+43.00	10	13	16		14.5			
NB	642+36.00	8	13	16		11.6			
SB	642+36.00	8	13	16		11.6			
NB	646+12.00	30	13	16				43.4	
SB	646+12.00	15	13	16			21.7		
NB	647+94.00	10	13	16		14.5			
SB	647+94.00	10	13	16		14.5			
NB	660+75.00	6	13	16		8.7			
SB	660+75.00	6	13	16		8.7			
NB	661+93.00	20	13	16				28.9	
SB	661+93.00	20	13	16				28.9	
NB	662+29.00	8	13	16		11.6			
SB	662+29.00	8	13	16		11.6			
NB	666+45.00	10	13	16		14.5			
SB	666+45.00	10	13	16		14.5			
NB	675+70.00	8	13	16		11.6			
SB	675+70.00	8	13	16		11.6			
NB	683+88.00	6	13	16		8.7			
SB	683+88.00	6	13	16		8.7			
SB	684+33.00	8	13	16		11.6			
NB	712+98.00	8	13	16		11.6			
SB	712+98.00	8	13	16		11.6			
NB	720+18.00	6	13	16		8.7			
SB	720+18.00	6.00	13.00	16		8.7			
NB	903+78.00	75.00	13.00	16				108.4	
SB	903+78.00	20.00	13.00	16				28.9	
SUB-TOTALS =					29.0	461.1	110.2	39.1	361.5
ROUNDED SUB-TOTALS =					29.0	462.0	111.0	40.0	362.0
TOTALS =					29.0	573.0	40.0	362.0	

MODEL: I:\MODEL\MHFS
 FILE: MHFS_Plan\Illinois.pwd\DOT\Documents\DOT_Offices\Illinet\Projects\0570D56\CADD\Design\0570D56-ht-Schedule.dgn

USER NAME = PiersonTJ	DESIGNED -	REVISED -
	DRAWN -	REVISED -
PLOT SCALE = 40.0000' / in.	CHECKED -	REVISED -
PLOT DATE = 3/22/2019	DATE -	REVISED -

**STATE OF ILLINOIS
DEPARTMENT OF TRANSPORTATION**

SCHEDULE OF QUANTITIES

SCALE: SHEET 10 OF 19 SHEETS STA. TO STA.

F.A.P. RTE.	SECTION	COUNTY	TOTAL SHEETS	SHEET NO.
836	**	-	214	26
CONTRACT NO. 70D56				

SCHEDULE OF QUANTITIES

AGGREGATE WEDGE SHOULDER SCHEDULE								
SIDE	STATION	DESCRIPTION	WIDTH FT	LENGTH FT	AREA SQ FT	THICKNESS IN	HSIP	
							CHAMPAIGN	VERMILION
							48102100	
AGGREGATE WEDGE SHOULDER, TY B							TON	
RT	333+63.85	FE71	2	19.2	38.4	3		0.6
LT	338+18.62	FE70	2	18.2	36.4	3		0.6
LT	347+02.30	FE68	2	20.4	40.8	3		0.7
RT	360+38.62	FE67	2	19.0	38	3		0.6
LT	387+13.96	FE64	2	22.9	45.8	3		0.8
RT	387+27.43	FE63	2	22.4	44.8	3		0.7
LT	399+96.72	FE62	2	21.7	43.4	3		0.7
RT	400+02.94	FE61	2	19.2	38.4	3		0.6
RT	405+40.20	PE25	2	31.8	63.6	3		1.1
LT	413+52.05	FE60	2	20.6	41.2	3		0.7
RT	429+95.42	FE59	2	28.5	57	3	1	
LT	450+71.32	FE58	2	30.2	60.4	3	1	
RT	451+06.90	FE57	2	33.6	67.2	3	1.1	
LT	463+71.22	FE56	2	24.8	49.6	3	0.8	
RT	479+37.29	FE55	2	23.4	46.8	3	0.8	
LT	479+39.89	FE54	2	29.5	59	3	1	
LT	486+36.94	FE53	2	15.2	30.4	3	0.5	
RT	492+45.90	FE52	2	37.6	75.2	3	1.3	
RT	501+42.46	FE51	2	27.5	55	3	0.9	
LT	501+47.09	PE20	2	65.7	131.4	3	2.2	
RT	505+48.64	PE19	2	20.6	41.2	3	0.7	
LT	505+51.96	FE50	2	21.3	42.6	3	0.7	
RT	513+52.55	FE49	2	33.1	66.2	3	1.1	
LT	514+67.32	FE48	2	18.2	36.4	3	0.6	
RT	522+21.96	FE47	2	31.0	62	3	1	
RT	545+04.39	FE46	2	20.5	41	3	0.7	
LT	545+23.19	FE45	2	13.4	26.8	3	0.4	
RT	554+73.00	FE44	2	11.8	23.6	3	0.4	
LT	558+43.61	FE43	2	46.3	92.6	3	1.5	
RT	565+01.49	FE42	2	16.5	33	3	0.6	
LT	571+46.62	FE41	2	21.3	42.6	3	0.7	
RT	578+65.98	FE40	2	21.9	43.8	3	0.7	
LT	580+22.92	FE39	2	23.6	47.2	3	0.8	
RT	584+75.30	FE38	2	17.8	35.6	3	0.6	
SCHEDULE BREAK SUB-TOTALS =							21.1	7.1

AGGREGATE WEDGE SHOULDER SCHEDULE								
SIDE	STATION	DESCRIPTION	WIDTH FT	LENGTH FT	AREA SQ FT	THICKNESS IN	HSIP	
							CHAMPAIGN	VERMILION
							48102100	
AGGREGATE WEDGE SHOULDER, TY B							TON	
RT	598+05.81	FE37	2	25.2	50.4	3	0.8	
LT	600+25.31	PE13	2	21.6	43.2	3	0.7	
RT	601+17.03	FE36	2	31.3	62.6	3	1	
LT	601+53.76	FE35	2	26.0	52	3	0.9	
RT	611+38.13	FE34	2	16.0	32	3	0.5	
LT	613+02.05	FE33	2	17.6	35.2	3	0.6	
LT	624+45.36	FE32	2	15.9	31.8	3	0.5	
RT	624+62.15	FE31	2	15.7	31.4	3	0.5	
RT	651+39.23	FE30	2	11.6	23.2	3	0.4	
RT	663+52.12	FE29	2	29.0	58	3	1	
LT	676+98.97	FE28	2	27.8	55.6	3	0.9	
RT	677+29.86	FE27	2	12.5	25	3	0.4	
RT	690+99.73	FE25	2	18.7	37.4	3	0.6	
LT	730+85.34	FE23	2	45.6	91.2	3	1.5	
RT	731+02.74	FE22	2	29.2	58.4	3	1	
RT	743+13.51	FE21	2	21.9	43.8	3	0.7	
LT	759+39.72	PE8	2	29.9	59.8	3	1	
RT	761+13.54	FE20	2	9.5	19	3	0.3	
RT	770+27.77	FE19	2	34.1	68.2	3	1.1	
LT	770+82.89	FE18	2	15.8	31.6	3	0.5	
RT	772+25.51	PE6	2	23.4	46.8	3	0.8	
LT	777+54.86	FE17	2	57.1	114.2	3	1.9	
RT	783+99.41	FE16	2	28.9	57.8	3	1	
LT	801+94.64	FE15	2	18.2	36.4	3	0.6	
RT	813+01.53	FE14	2	16.5	33	3	0.6	
LT	813+65.37	FE13	2	21.1	42.2	3	0.7	
LT	856+84.34	FE12	2	22.4	44.8	3	0.7	
LT	861+17.94	FE11	2	26.1	52.2	3	0.9	
LT	864+19.01	FE10	2	27.4	54.8	3	0.9	
RT	865+36.69	PE2	2	22.3	44.6	3	0.7	
LT	876+47.45	FE9	2	31.9	63.8	3	1.1	
RT	876+54.19	FE8	2	10.7	21.4	3	0.4	
LT	889+64.78	FE7	2	21.2	42.4	3	0.7	
RT	891+79.16	FE6	2	8.9	17.8	3	0.3	
LT	894+11.18	FE5	2	12.9	25.8	3	0.4	
RT	901+59.69	FE4	2	21.9	43.8	3	0.7	
LT	902+52.66	FE3	2	43.1	86.2	3	1.4	
SUB-TOTALS =							49.8	7.1
ROUNDED SUB-TOTALS =							50	8
TOTAL =							58	

MODEL: I:\MODEL\MHFS
 FILE: MHFS_Plan\Illinois.pwd\DOT\Documents\DOT_Office\Drawings\Projects\0570D56\HSIP\Schedule.sdm

USER NAME = PiersonTJ	DESIGNED -	REVISED -
	DRAWN -	REVISED -
PLOT SCALE = 40.0000 ' / in.	CHECKED -	REVISED -
PLOT DATE = 3/22/2019	DATE -	REVISED -

**STATE OF ILLINOIS
DEPARTMENT OF TRANSPORTATION**

SCHEDULE OF QUANTITIES			
SCALE:	SHEET 11 OF 19 SHEETS	STA.	TO STA.

F.A.P. RTE.	SECTION	COUNTY	TOTAL SHEETS	SHEET NO.
836	**	-	214	27
			CONTRACT NO. 70D56	

SCHEDULE OF QUANTITIES

GUARDRAIL SCHEDULE																
STR. NO.	SIDE		STATION	TO	STATION	HSIP	HSIP	HSIP	HSIP	HSIP	HSIP	HSIP	HSIP	HSIP		
						CHAMPAIGN	CHAMPAIGN	CHAMPAIGN	CHAMPAIGN	CHAMPAIGN	CHAMPAIGN	CHAMPAIGN	CHAMPAIGN	CHAMPAIGN	CHAMPAIGN	CHAMPAIGN
						63000001	63000370	63100045	63100085	63100167	63200310	72501000	78200005	X6310188	X6330725	
STEEL PLATE BEAM GUARDRAIL TY A, 6 FT	LONG SPAN GUARDRAIL OVER CULV. 25 FT SPAN	TRAFFIC BARRIER TERMINAL TY-2	TRAFFIC BARRIER TERMINAL TY-6	TRAFFIC BARRIER TERMINAL TY-1 SPL TANGENT	GUARDRAIL REMOVAL	TERMINAL MARKER DIRECT APPLIED	GUARDRAIL REFLECTORS TYPE A	TRAFFIC BARRIER TERMINAL TY-6A MODIFIED	STEEL PLATE BEAM GUARDRAIL (SHORT RADIUS)							
						FOOT	FOOT	EACH	EACH	EACH	FOOT	EACH	EACH	FOOT		
010-8104	NB	APPR	489+62.18	TO	491+49.67	100.0	50			1.0	110.9	1	3			
010-8104	NB	DEP	491+49.67	TO	492+12.18	12.5				1.0	64.9	1	1			
010-8104	SB	APPR	493+11.89	TO	491+24.40	100.0	50			1.0	110.4	1	3			
010-8104	SB	DEP	491+24.40	TO	490+61.90	12.5				1.0	89.1	1	1			
010-0236	NB	APPR	661+52.59	TO	663+30.79	125.0		1.0		1.0	189.0	1	2	12.5		
010-0236	NB	APPR	663+67.45	TO	664+26.20	12.5		1.0			69.0		1	1		
010-0236	NB	DEP	665+01.35	TO	666+69.99	25.0			1.0		170.0	1	2	1		
010-0236	SB	APPR	667+63.37	TO	664+82.50	125.0			1.0		281.0	1	2	1		
010-0236	SB	DEP	664+07.03	TO	662+36.65	25.0			1.0		171.0	1	2	1		
010-0284	SB	APPR	690+26.61	TO	690+76.66				1.0		68.9	1				
010-0269	NB	APPR	727+44.79	TO	729+32.29	100.0			1.0		40.1	1	2	1		
010-0269	NB	DEP	729+64.45	TO	730+76.95	25.0			1.0		40.1	1	2	1		
010-0269	SB	APPR	731+64.56	TO	729+64.51	50.0		1.0			40.1		1	1		
010-0269	SB	APPR	731+06.71	TO	731+64.56			1.0		1.0		1	1	12.5		
010-0269	SB	DEP	729+32.38	TO	728+19.88	25.0			1.0		40.1	1	2	1		
010-0268	NB	APPR	902+37.48	TO	903+13.44	25.0		1.0		1.0		1	1	12.5		
010-0268	NB	APPR	903+52.03	TO	904+02.93			1.0			52.0		1	1		
010-0268	NB	DEP	904+45.67	TO	905+48.15	25.0			1.0		102.9	1	2			
010-0268	SB	APPR	904+45.43	TO	905+72.70	87.5			1.0		127.5	1	2			
010-0268	SB	DEP	902+69.54	TO	904+03.10	25.0			1.0		140.5	1	2			
TOTALS =						900.0	100.0	6.0	4.0	17.0	1,907.5	17.0	33.0	8.0	75.0	
ROUNDED TOTALS =						900.0	100.0	6.0	4.0	17.0	1,908.0	17.0	33.0	8.0	75.0	

SURVEY MARKER VAULT SCHEDULE							
POINT #	NORTHING	EASTING	STATION	OFSETT	DESCRIPTION	SMART	
						CHAMPAIGN	
						VERMILION	
						Z0070202	
						SURVEY MARKER VAULT	
						EACH	
217	1173009	1095267.6	347+12.27	1.44	EXISTING VAULT FOUND	1	
218	1175668.9	1095242.4	373+72.31	9.49	MAG NAIL FOUND	1	
219	1178311.3	1095204.2	400+14.98	4.28	MAG NAIL FOUND	1	
221	1180887.5	1089857.7	479+00.21	-3.05	SURVEY SPIKE FOUND	1	
222	1183531	1089828.5	505+43.54	0.40	SURVEY SPIKE FOUND	1	
223	1188822.8	1089769.4	558+35.66	0.23	MAG NAIL FOUND	1	
224	1191471.9	1089740.2	584+85.00	0.43	MAG NAIL FOUND	1	
225	1192790.9	1089725.7	598+04.08	0.60	EXISTING VAULT FOUND	1	
226	1194113.9	1089708.8	611+27.17	-1.55	EXISTING VAULT FOUND	1	
227	1196757.5	1089677.5	637+70.94	-3.44	VAULT DESTROYED	1	
228	1198080.5	1089662.6	650+93.98	-3.65	EXISTING VAULT FOUND	1	
229	1199403.4	1089647.5	664+16.98	-4.03	CHISLED 'X' FOUND ON BRIDGE DECK	1	
230	1202105.8	1089617	691+19.60	-4.39	EXISTING VAULT FOUND	1	
231	1207408.8	1089515.7	744+24.50	-0.80	EXISTING VAULT FOUND	1	
232	1210060.7	1089501.6	770+76.45	1.77	MAG NAIL FOUND	1	
233	1212712.5	1089486.7	797+28.24	3.91	MAG NAIL FOUND	1	
234	1215360.7	1089450.3	823+76.76	-6.44	MAG NAIL FOUND	1	
235	1218000.7	1089429.1	850+16.82	0.32	MAG NAIL FOUND	1	
236	1220640.5	1089401.1	876+56.78	0.22	MAG NAIL FOUND	1	
237	1223280	1089373	902+96.43	0.07	EXISTING VAULT FOUND	1	
SUB-TOTALS =						17.00	3.00
TOTALS =						20.00	

TYPE 2 SURVEY MARKER SCHEDULE							
POINT #	DESCRIPTION	NORTHING	EASTING	STATION	OFSETT	COMMENT	SMART
							CHAMPAIGN
							XZ193400
							SURVEY MARKER TY. 2 SPL
							EACH
68	PI KINK	1180900.4	1092838.9	447+47.21	0.00	MAG NAIL SET	1
88	PI KINK	1200737.3	1089636.7	677+50.91	0.00	EXISTING I.P. FOUND	1
89	PI	1202461.2	1089618.1	694+74.83	6.82	MAG NAIL SET	1
PRC109	PRC	1202959	1089585.5	699+73.51	0.00	MAG NAIL SET	1
109	PI	1203651.6	1089540.1	706+67.47	-10.27	MAG NAIL SET	1
110	PI	1213103.1	1089480.7	801+18.87	1.08	MAG NAIL SET	1
100	POT	1224642.1	1089358.5	916+58.55	0.00	EXISTING MAG NAIL FOUND (OUTSIDE SURVEY LIMITS)	1
TOTALS =							7.00

MODEL: \\MODEL\MARIS
FILE: \\MARIS_Plan\p118050001.dwg
PROJECT: \\PROJECTS\118050001\Documents\118050001.dwg
OFFICE: \\OFFICE\118050001\118050001.dwg
DATE: 4/3/2019

USER NAME = PiersonTJ	DESIGNED -	REVISED -
	DRAWN -	REVISED -
PLOT SCALE = 40.0000 ' / in.	CHECKED -	REVISED -
PLOT DATE = 4/3/2019	DATE -	REVISED -

**STATE OF ILLINOIS
DEPARTMENT OF TRANSPORTATION**

SCHEDULE OF QUANTITIES			
SCALE:	SHEET 14 OF 19 SHEETS	STA.	TO STA.

F.A.P. RTE. 836	SECTION **	COUNTY -	TOTAL SHEETS 214	SHEET NO. 30
CONTRACT NO. 70D56				
ILLINOIS FED. AID PROJECT				

SCHEDULE OF QUANTITIES

RUMBLE STRIP SCHEDULE						
NORTHTBOUND LANE						
STATION	TO	STATION	LENGTH FOOT	REASON FOR STATION BREAK	HSIP	
					CHAM	VERM
					64200108 SHOULDER RUMBLE STRIP, 8"	
					FOOT	
321+00.00	TO	333+49.64	1,249.64	MAINLINE		1,249.7
333+49.64	TO	333+81.38	31.74	FE		
333+81.38	TO	345+03.13	1,121.75	MAINLINE		1,121.8
345+03.13	TO	345+32.53	29.40	FE		
345+32.53	TO	360+22.63	1,490.10	MAINLINE		1,490.1
360+22.63	TO	360+57.39	34.76	FE		
360+57.39	TO	373+53.08	1,295.69	MAINLINE		1,295.7
373+53.08	TO	373+96.85	43.77	E 200 NORTH RD		
373+96.85	TO	387+08.67	1,311.82	MAINLINE		1,311.9
387+08.67	TO	387+47.07	38.40	FE		
387+47.07	TO	399+85.77	1,238.70	MAINLINE		1,238.7
399+85.77	TO	400+23.49	37.72	FE		
400+23.49	TO	405+21.52	498.03	MAINLINE		498.1
405+21.52	TO	405+61.34	39.82	PE		
405+61.34	TO	408+63.73	302.39	MAINLINE		302.4
408+63.73	TO	408+91.76	28.03	PE		
408+91.76	TO	418+72.85	981.09	MAINLINE		981.1
418+72.85	TO	419+56.93	84.08	PE		
419+56.93	TO	420+29.01	72.08	MAINLINE		72.1
420+29.01	TO	420+85.98	56.97	PE		
420+85.98	TO	421+77.05	91.07	MAINLINE		91.1
421+77.05	TO	422+08.42	31.37	MAINLINE	31.4	
422+08.42	TO	423+27.19	118.77	ENGLISH ST + CR 2800E		
423+27.19	TO	427+38.42	411.23	MAINLINE	411.3	
427+38.42	TO	428+71.54	133.12	E. YATES ST.		
428+71.54	TO	429+71.00	99.46	MAINLINE	99.5	
429+71.00	TO	430+24.38	53.38	FE		
430+24.38	TO	450+83.04	2,058.66	MAINLINE	2,058.7	
450+83.04	TO	451+29.66	46.62	FE		
451+29.66	TO	479+17.96	2,788.30	MAINLINE	2,788.3	
479+17.96	TO	479+58.82	40.86	FE		
479+58.82	TO	486+04.93	646.11	MAINLINE	646.2	
486+04.93	TO	486+68.95	64.02	PE		
486+68.95	TO	489+62.18	293.23	MAINLINE	293.3	
489+62.18	TO	492+12.18	250.00	GUARDRAIL + SN 010-8104		
492+12.18	TO	492+25.76	13.58	MAINLINE	13.6	
492+25.76	TO	492+63.82	38.06	FE		
492+63.82	TO	501+27.89	864.07	MAINLINE	864.1	
501+27.89	TO	501+55.70	27.81	FE		
501+55.70	TO	505+37.16	381.46	MAINLINE	381.5	
505+37.16	TO	505+65.96	28.80	PE		
505+65.96	TO	506+45.55	79.59	MAINLINE	79.6	
506+45.55	TO	506+78.32	32.77	PE		
506+78.32	TO	513+33.37	655.05	MAINLINE	655.1	
513+33.37	TO	513+79.31	45.94	FE		
513+79.31	TO	514+50.97	71.66	MAINLINE	71.7	
514+50.97	TO	514+81.52	30.55	PE		
514+81.52	TO	522+06.44	724.92	MAINLINE	725.0	
522+06.44	TO	522+37.98	31.54	FE		
522+37.98	TO	531+72.54	934.56	MAINLINE	934.6	
531+72.54	TO	532+17.66	45.12	CR 300N		
532+17.66	TO	544+95.49	1,277.83	MAINLINE	1,277.9	
544+95.49	TO	545+16.20	20.71	FE		
545+16.20	TO	544+68.87	-47.33	MAINLINE	-47.4	
544+68.87	TO	554+80.35	1,011.48	FE		
554+80.35	TO	564+93.14	1,012.79	MAINLINE	1,012.8	
564+93.14	TO	565+09.83	16.69	FE		
565+09.83	TO	571+34.09	624.26	MAINLINE	624.3	
SCHEDULE BREAK SUB-TOTALS =					12,921.5	9,652.7

RUMBLE STRIP SCHEDULE						
NORTHTBOUND LANE						
STATION	TO	STATION	LENGTH FOOT	REASON FOR STATION BREAK	HSIP	
					CHAM	VERM
					64200108 SHOULDER RUMBLE STRIP, 8"	
					FOOT	
571+34.09	TO	571+77.00	42.91	CR 375N		
571+77.00	TO	578+57.01	680.01	MAINLINE	680.1	
578+57.01	TO	578+79.22	22.21	FE		
578+79.22	TO	584+66.53	587.31	MAINLINE	587.4	
584+66.53	TO	584+84.37	17.84	FE		
584+84.37	TO	595+38.42	1,054.05	MAINLINE	1,054.1	
595+38.42	TO	595+65.04	26.62	PE		
595+65.04	TO	597+94.32	229.28	MAINLINE	229.3	
597+94.32	TO	598+19.30	24.98	FE		
598+19.30	TO	601+09.03	289.73	MAINLINE	289.8	
601+09.03	TO	601+41.59	32.56	FE		
601+41.59	TO	611+29.75	988.16	MAINLINE	988.2	
611+29.75	TO	611+45.96	16.21	FE		
611+45.96	TO	624+53.59	1,307.63	MAINLINE	1,307.7	
624+53.59	TO	624+69.51	15.92	FE		
624+69.51	TO	637+58.02	1,288.51	MAINLINE	1,288.6	
637+58.02	TO	638+07.88	49.86	CR 500N		
638+07.88	TO	646+13.68	805.80	MAINLINE	805.9	
646+13.68	TO	646+80.39	66.71	PE		
646+80.39	TO	651+32.64	452.25	MAINLINE	452.3	
651+32.64	TO	651+44.24	11.60	FE		
651+44.24	TO	661+52.59	1,008.35	MAINLINE	1,008.4	
661+52.59	TO	666+69.99	517.40	GUARDRAIL + FE + SN 010-0236		
666+69.99	TO	677+25.53	1,055.54	MAINLINE	1,055.6	
677+25.53	TO	677+38.04	12.51	FE		
677+38.04	TO	686+26.44	888.40	MAINLINE	888.5	
686+26.44	TO	690+77.85	451.41	GUARDRAIL + FE + SN 01-0284		
690+77.85	TO	690+91.60	13.75	MAINLINE	13.8	
690+91.60	TO	691+09.88	18.28	FE		
691+09.88	TO	705+39.05	1,429.17	MAINLINE	1,429.2	
705+39.05	TO	705+76.87	37.82	PE		
705+76.87	TO	727+44.79	2,167.92	MAINLINE	2,168.0	
727+44.79	TO	731+12.17	367.38	GUARDRAIL + SN 010-0269 + FE		
731+12.17	TO	743+02.14	1,189.97	MAINLINE	1,190.0	
743+02.14	TO	743+24.12	21.98	FE		
743+24.12	TO	743+98.06	73.94	MAINLINE	74.0	
743+98.06	TO	744+56.62	58.56	CR 700N		
744+56.62	TO	751+42.62	686.00	MAINLINE	686.0	
751+42.62	TO	755+09.37	366.75	GUARDRAIL + SN 010-8171		
755+09.37	TO	761+09.30	599.93	MAINLINE	600.0	
761+09.30	TO	761+18.78	9.48	FE		
761+18.78	TO	770+09.71	890.93	MAINLINE	891.0	
770+09.71	TO	770+44.05	34.34	FE		
770+44.05	TO	772+08.38	164.33	MAINLINE	164.4	
772+08.38	TO	772+43.27	34.89	PE		
772+43.27	TO	783+87.72	1,144.45	MAINLINE	1,144.5	
783+87.72	TO	784+16.69	28.97	FE		
784+16.69	TO	797+00.19	1,283.50	MAINLINE	1,283.5	
797+00.19	TO	797+51.25	51.06	CR 800N		
797+51.25	TO	812+91.02	1,539.77	MAINLINE	1,539.8	
812+91.02	TO	813+08.72	17.70	FE		
813+08.72	TO	848+05.67	3,496.95	MAINLINE	3,497.0	
848+05.67	TO	848+41.48	35.81	PE		
SCHEDULE BREAK SUB-TOTALS =					25,317.1	0.0

RUMBLE STRIP SCHEDULE						
NORTHTBOUND LANE						
STATION	TO	STATION	LENGTH FOOT	REASON FOR STATION BREAK	HSIP	
					CHAM	VERM
					64200108 SHOULDER RUMBLE STRIP, 8"	
					FOOT	
848+41.48	TO	865+25.69	1,684.21	MAINLINE	1,684.3	
865+25.69	TO	865+56.32	30.63	PE		
865+56.32	TO	876+49.16	1,092.84	MAINLINE	1,092.9	
876+49.16	TO	876+60.03	10.87	FE		
876+60.03	TO	891+74.93	1,514.90	MAINLINE	1,514.9	
891+74.93	TO	891+83.81	8.88	FE		
891+83.81	TO	901+49.17	965.36	MAINLINE	965.4	
901+49.17	TO	901+91.17	42.00	FE		
901+91.17	TO	902+24.98	33.81	MAINLINE	33.9	
902+24.98	TO	903+82.91	157.93	GUARDRAIL + FE		
NORTHBOUND TOTALS =					43,530.0	9,652.7

64200108 CONTINUES ON SHEET: 32

MODEL: I:\MODEL\MHFS...
FILE: I:\MHFS...
PROJECT: I:\PROJECTS\DOT...
DATE: 3/22/2019

USER NAME = PiersonTJ	DESIGNED -	REVISED -
PLOT SCALE = 40,0000 ' / in.	DRAWN -	REVISED -
PLOT DATE = 3/22/2019	CHECKED -	REVISED -
	DATE -	REVISED -

STATE OF ILLINOIS
DEPARTMENT OF TRANSPORTATION

SCHEDULE OF QUANTITIES

SCALE:	SHEET 15 OF 19 SHEETS	STA.	TO STA.	F.A.P. RTE. 836	SECTION **	COUNTY -	TOTAL SHEETS 214	SHEET NO. 31
				CONTRACT NO. 70D56				
				ILLINOIS FED. AID PROJECT				
				**118RS-3,119RS-4,D5 HSIP 2019-1				
				*CHAMPAIGN & VERMILION				

SCHEDULE OF QUANTITIES

RUMBLE STRIP SCHEDULE						
SOUTHBOUND LANE						
STATION	TO	STATION	LENGTH FOOT	REASON FOR STATION BREAK	HSIP	
					CHAM	VERM
					64200108 SHOULDER RUMBLE STRIP, 8"	
					FOOT	
321+00.00	TO	331+01.46	1,001.46	MAINLINE		1,001.5
331+01.46	TO	331+34.35	32.89	FE		
331+34.35	TO	338+01.81	667.46	MAINLINE		667.5
338+01.81	TO	338+38.93	37.12	FE		
338+38.93	TO	342+68.03	429.10	MAINLINE		429.1
342+68.03	TO	343+40.43	72.40	PE		
343+40.43	TO	346+83.63	343.20	MAINLINE		343.2
346+83.63	TO	347+23.21	39.58	FE		
347+23.21	TO	354+34.56	711.35	MAINLINE		711.4
354+34.56	TO	354+99.14	64.58	PE		
354+99.14	TO	356+88.08	188.94	MAINLINE		189.0
356+88.08	TO	357+26.99	38.91	PE		
357+26.99	TO	371+98.03	1,471.04	MAINLINE		1,471.1
371+98.03	TO	372+33.44	35.41	FE		
372+33.44	TO	373+19.10	85.66	MAINLINE		85.7
373+19.10	TO	374+01.13	82.03	FE+ CR 100N		
374+01.13	TO	386+92.11	1,290.98	MAINLINE		1,291.0
386+92.11	TO	387+28.15	36.04	FE		
387+28.15	TO	399+76.52	1,248.37	MAINLINE		1,248.4
399+76.52	TO	400+12.54	36.02	FE		
400+12.54	TO	413+41.26	1,328.72	MAINLINE		1,328.8
413+41.26	TO	413+61.84	20.58	FE		
413+61.84	TO	421+77.05	815.21	MAINLINE		815.3
421+77.05	TO	450+41.00	2,863.95	MAINLINE		2,864.0
450+41.00	TO	450+91.64	50.64	FE		
450+91.64	TO	463+47.40	1,255.76	MAINLINE		1,255.8
463+47.40	TO	463+93.47	46.07	FE		
463+93.47	TO	477+67.24	1,373.77	MAINLINE		1,373.8
477+67.24	TO	479+16.09	148.85	CR 2700E + BROADLANDS RD		
479+16.09	TO	479+24.31	8.22	MAINLINE		8.3
479+24.31	TO	479+63.88	39.57	FE		
479+63.88	TO	486+16.97	653.09	MAINLINE		653.1
486+16.97	TO	486+50.33	33.36	FE		
486+50.33	TO	490+61.90	411.57	MAINLINE		411.6
490+61.90	TO	493+11.89	249.99	GUARDRAIL + SN 010-8104		
493+11.89	TO	500+92.79	780.90	MAINLINE		781.0
500+92.79	TO	501+57.55	64.76	PE		
501+57.55	TO	505+34.09	376.54	MAINLINE		376.6
505+34.09	TO	505+68.85	34.76	FE		
505+68.85	TO	514+51.16	882.31	MAINLINE		882.4
514+51.16	TO	514+82.13	30.97	FE		
514+82.13	TO	519+37.06	454.93	MAINLINE		455.0
519+37.06	TO	519+72.61	35.55	PE		
519+72.61	TO	531+68.25	1,195.64	MAINLINE		1,195.7
531+68.25	TO	532+22.00	53.75	CR 300N		
532+22.00	TO	545+05.37	1,283.37	MAINLINE		1,283.4
545+05.37	TO	545+37.12	31.75	FE		
545+37.12	TO	558+08.42	1,271.30	MAINLINE		1,271.3
558+08.42	TO	558+74.93	66.51	FE		
558+74.93	TO	571+28.76	1,253.83	MAINLINE		1,253.9
571+28.76	TO	571+62.02	33.26	FE		
571+62.02	TO	580+04.44	842.42	MAINLINE		842.5
580+04.44	TO	580+40.69	36.25	FE		
580+40.69	TO	584+54.68	413.99	MAINLINE		414.0
584+54.68	TO	585+21.49	66.81	CR 400N		
585+21.49	TO	594+32.86	911.37	MAINLINE		911.4
594+32.86	TO	595+03.21	70.35	PE		
595+03.21	TO	600+10.59	507.38	MAINLINE		507.4
SCHEDULE BREAK SUB-TOTALS =					16,741.2	9,582.0

RUMBLE STRIP SCHEDULE						
SOUTHBOUND LANE						
STATION	TO	STATION	LENGTH FOOT	REASON FOR STATION BREAK	HSIP	
					CHAM	VERM
					64200108 SHOULDER RUMBLE STRIP, 8"	
					FOOT	
600+10.59	TO	600+40.95	30.36	PE		
600+40.95	TO	601+22.66	81.71	MAINLINE		81.8
601+22.66	TO	601+58.02	35.36	FE		
601+58.02	TO	612+89.48	1,131.46	MAINLINE		1,131.5
612+89.48	TO	613+18.33	28.85	FE		
613+18.33	TO	624+31.05	1,112.72	MAINLINE		1,112.8
624+31.05	TO	624+61.66	30.61	FE		
624+61.66	TO	637+48.36	1,286.70	MAINLINE		1,286.7
637+48.36	TO	638+02.31	53.95	CR 500N		
638+02.31	TO	652+63.38	1,461.07	MAINLINE		1,461.1
652+63.38	TO	653+01.21	37.83	PE		
653+01.21	TO	662+36.65	935.44	MAINLINE		935.5
662+36.65	TO	667+63.37	526.72	GUARDRAIL + SN 010-0236		
667+63.37	TO	676+75.79	912.42	MAINLINE		912.5
676+75.79	TO	677+18.90	43.11	FE		
677+18.90	TO	678+76.62	157.72	MAINLINE		157.8
678+76.62	TO	679+17.76	41.14	PE		
679+17.76	TO	686+25.38	707.62	MAINLINE		707.7
686+25.38	TO	691+66.24	540.86	PCC SHOULDER + GUARDRAIL + CR 600N		
691+66.24	TO	701+39.52	973.28	MAINLINE		973.3
701+39.52	TO	701+88.27	48.75	FE		
701+88.27	TO	728+19.88	2,631.61	MAINLINE		2,631.7
728+19.88	TO	731+64.56	344.68	GUARDRAIL + SN 010-0269		
731+64.56	TO	744+00.86	1,236.30	MAINLINE		1,236.3
744+00.86	TO	744+55.64	54.78	CR 700N		
744+55.64	TO	751+42.81	687.17	MAINLINE		687.2
751+42.81	TO	755+08.85	366.04	GUARDRAIL + SN 010-8170 + SN 010-8171		
755+08.85	TO	759+23.89	415.04	MAINLINE		415.1
759+23.89	TO	759+60.02	36.13	PE		
759+60.02	TO	767+96.28	836.26	MAINLINE		836.3
767+96.28	TO	768+42.91	46.63	PE		
768+42.91	TO	770+63.61	220.70	MAINLINE		220.7
770+63.61	TO	771+04.34	40.73	FE		
771+04.34	TO	777+17.49	613.15	MAINLINE		613.2
777+17.49	TO	777+91.10	73.61	FE		
777+91.10	TO	797+04.01	1,912.91	MAINLINE		1,913.0
797+04.01	TO	797+51.85	47.84	CR 800N		
797+51.85	TO	801+77.11	425.26	MAINLINE		425.3
801+77.11	TO	802+11.54	34.43	FE		
802+11.54	TO	813+47.97	1,136.43	MAINLINE		1,136.5
813+47.97	TO	813+84.24	36.27	FE		
813+84.24	TO	847+92.75	3,408.51	MAINLINE		3,408.6
847+92.75	TO	848+59.65	66.90	PE		
848+59.65	TO	849+90.16	130.51	MAINLINE		130.6
849+90.16	TO	850+43.53	53.37	CR 900N		
850+43.53	TO	856+65.63	622.10	MAINLINE		622.2
856+65.63	TO	857+00.40	34.77	FE		
857+00.40	TO	858+32.37	131.97	MAINLINE		132.0
858+32.37	TO	859+13.53	81.16	PE		
859+13.53	TO	860+97.17	183.64	MAINLINE		183.7
860+97.17	TO	861+36.83	39.66	FE		
861+36.83	TO	864+05.84	269.01	MAINLINE		269.1
864+05.84	TO	864+33.45	27.61	FE		
864+33.45	TO	876+24.60	1,191.15	MAINLINE		1,191.2
SCHEDULE BREAK SUB-TOTALS =					24,813.4	0.0

RUMBLE STRIP SCHEDULE						
SOUTHBOUND LANE						
STATION	TO	STATION	LENGTH FOOT	REASON FOR STATION BREAK	HSIP	
					CHAM	VERM
					64200108 SHOULDER RUMBLE STRIP, 8"	
					FOOT	
876+24.60	TO	876+68.15	43.55	FE		
876+68.15	TO	889+43.13	1,274.98	MAINLINE		1,275.0
889+43.13	TO	889+78.56	35.43	FE		
889+78.56	TO	893+95.86	417.30	MAINLINE		417.4
893+95.86	TO	894+25.67	29.81	FE		
894+25.67	TO	902+24.40	798.73	MAINLINE		798.8
902+24.40	TO	902+76.16	51.76	FE		
902+76.16	TO	902+90.60	14.44	MAINLINE		14.5
902+90.60	TO	903+82.91	92.31	GUARDRAIL		
SOUTHBOUND SUB-TOTALS =					44,060.3	9,582.0
SUB-TOTALS =					87,590.3	19,234.7
ROUNDED SUB-TOTALS =					87,591.0	19,235.0
TOTALS =					106,826.0	

64200108 CONTINUES ON SHEET: 31

MODEL: \\MODEL\NAMES
FILE: \\MAILS\proj\118RS-3\118RS-4\Design\118RS-4\118RS-4-D5 HSIP Schedule.dgn

USER NAME = PiersonTJ	DESIGNED -	REVISED -	STATE OF ILLINOIS DEPARTMENT OF TRANSPORTATION	SCHEDULE OF QUANTITIES	F.A.P. RTE.	SECTION	COUNTY	TOTAL SHEETS	SHEET NO.
PLOT SCALE = 40.0000 ' / in.	CHECKED -	REVISED -			836	**	-	214	32
PLOT DATE = 3/22/2019	DATE -	REVISED -			CONTRACT NO. 70D56				
					SCALE:	SHEET 16 OF 19 SHEETS	STA. TO STA.	ILLINOIS FED. AID PROJECT	**118RS-3,118RS-4,D5 HSIP 2019-1 *CHAMPAIGN & VERMILION

SCHEDULE OF QUANTITIES

EOP PAVEMENT MARKING SCHEDULE								
STATION	TO	STATION	SMART		SMART		SMART	
			CHAMPAIGN	VERMILION	CHAMPAIGN	VERMILION	CHAMPAIGN	VERMILION
			70300100		70300220		78001110	
			SHORT TERM PAVEMENT MARKING LINE 4" FOOT		TEMP PAVEMENT MARKING LINE 4" (WHITE SOLID) FOOT		PAINT PAVEMENT MARKING LINE 4" (WHITE SOLID) FOOT	
NORTHBOUND LANE								
321+00.00	TO	373+53.08		210.12		5,253.08		5,253.08
OMISSION - E 200 NORTH ROAD								
373+96.84	TO	421+77.05		191.21		4,780.21		4,780.21
421+77.05	TO	422+08.38	1.25		31.33		31.33	
OMISSION - ENGLISH STREET & CR 2800 E								
423+27.53	TO	427+82.09	18.18		454.56		454.56	
OMISSION - E YATES STREET								
428+71.86	TO	531+72.54	412.03		10,300.68		10,300.68	
OMISSION - CR 300N								
532+17.66	TO	637+58.02	421.61		10,540.36		10,540.36	
OMISSION - CR 500N								
638+07.88	TO	743+98.06	423.61		10,590.18		10,590.18	
OMISSION - CR 700N								
744+56.61	TO	797+00.19	209.74		5,243.58		5,243.58	
OMISSION - CR 800N								
797+51.25	TO	902+00.00	417.95		10,448.75		10,448.75	
NORTHBOUND SUB-TOTALS =			1,904.38	401.33	47,609.44	10,033.29	47,609.44	10,033.29
SOUTHBOUND LANE								
321+00.00	TO	373+53.08		210.12		5,253.08		5,253.08
OMISSION - CR 100N								
374+01.12	TO	421+77.05		191.04		4,775.93		4,775.93
421+77.05	TO	477+67.06	223.60		5,590.01		5,590.01	
OMISSION - CR 2700 E & BROADLANDS ROAD								
479+16.01	TO	531+68.25	210.09		5,252.24		5,252.24	
OMISSION - CR 300N								
532+22.05	TO	584+54.44	209.30		5,232.39		5,232.39	
OMISSION - CR 400N								
585+21.49	TO	637+48.35	209.07		5,226.86		5,226.86	
OMISSION - CR 500N								
638+02.30	TO	690+78.47	211.05		5,276.17		5,276.17	
OMISSION - CR 600N								
691+57.90	TO	744+00.86	209.72		5,242.96		5,242.96	
OMISSION - CR 700N								
744+55.64	TO	797+04.01	209.93		5,248.37		5,248.37	
OMISSION - CR 800N								
797+51.85	TO	849+90.16	209.53		5,238.31		5,238.31	
OMISSION - CR 900N								
850+43.53	TO	903+82.91	213.58		5,339.38		5,339.38	
SOUTHBOUND SUB-TOTALS =			1,905.87	401.16	47,646.69	10,029.01	47,646.69	10,029.01
GRAND SUB-TOTALS =			3,810.25	802.49	95,256.13	20,062.30	95,256.13	20,062.30
ROUNDED SUB-TOTALS =			3,811.00	803.00	95,257.00	20,063.00	95,257.00	20,063.00
TOTALS =			4,614.00	115,320.00			115,320.00	

SIDEROAD PAVEMENT MARKING SCHEDULE			
LOCATION	SMART		SMART
	CHAMPAIGN	CHAMPAIGN	CHAMPAIGN
	70300100	70300220	78001110
	SHORT TERM PAVEMENT MARKING LINE 4" FOOT		PAINT PAVEMENT MARKING LINE 4" (WHITE SOLID) FOOT
CR 2800 E.	3.81		38.1
E YATES STREET	17.88		178.8
TOTALS =			
	21.69		216.90
ROUNDED TOTALS =			
	22.00		217.00

RAISED REFLECTOR SCHEDULE							
STA	TO	STA	LENGTH FOOT	SMART		SMART	
				CHAMPAIGN	VERMILION	CHAMPAIGN	VERMILION
				78100100		78300200	
				RAISED REFLECTIVE PAVEMENT MARKER EACH		RAISED REFLECTIVE PVT MK REMOVAL EACH	
321+00.00	TO	42101.71	10,001.71			125.0	125.0
421+01.71	TO	421+77.05	75.34	*CURVE		3.0	3.0
421+77.05	TO	429+80.00	802.95	*CURVE		30.0	30.0
429+80.00	TO	466+66.66	3,686.66			46.0	46.0
466+66.66	TO	479+90.00	1,323.34	*CURVE		51.0	51.0
479+90.00	TO	663+12.95	18,322.95			229.0	229.0
663+12.95	TO	665+78.19	265.24	SN 010-0236		0.0	0.0
665+78.19	TO	686+26.44	2,048.25			26.0	26.0
686+26.44	TO	690+77.80	451.36	SN 010-0284		0.0	0.0
690+77.80	TO	728+64.37	3,786.57			47.0	47.0
729+30.49	TO	729+66.49	36.00	SN 010-0269		0.0	0.0
729+66.49	TO	903+82.91	17,416.42			218.0	218.0
SUB-TOTALS =						647.0	128.0
TOTALS =						775.0	775.0

*AT CURVES PLACE AT CENTERLINE AND EDGE OF PAVEMENT. OMIT EDGE OF PAVEMENT REFLECTORS FOR ENTRANCES AND SIDEROADS 80 FT SPACING

MAINLINE CENTERLINE PAVEMENT MARKING SCHEDULE								
STATION	TO	STATION	SMART		SMART		SMART	
			CHAMPAIGN	VERMILION	CHAMPAIGN	VERMILION	CHAMPAIGN	VERMILION
			70300100		70300220		78001110	
			SHORT TERM PAVEMENT MARKING LINE 4" FOOT		TEMP PAVEMENT MARKING LINE 4" FOOT		PAINT PAVEMENT MARKING LINE 4" (YELLOW SKIP) FOOT	
321+00.00	TO	421+77.05		1,007.71		10,077.05		2,519.26
421+77.05	TO	903+82.91	4,820.59		48,205.86		12,051.47	
SUB-TOTALS =			4,820.59	1,007.71	48,205.86	10,077.05	12,051.47	2,519.26
ROUNDED SUB-TOTALS =			4,821.00	1,008.00	48,206.00	10,078.00	12,052.00	2,520.00
TOTALS =			5,829.00		58,284.00		14,572.00	

MODEL: I:\MODEL\NAME: FILE: I:\MODEL\NAME: PROJECT: I:\PROJECT\NAME: DRAWING: I:\DRAWING\NAME: SHEET: I:\SHEET\NAME

USER NAME = PiersonTJ	DESIGNED -	REVISED -
	DRAWN -	REVISED -
PLOT SCALE = 40.0000 ' / in.	CHECKED -	REVISED -
PLOT DATE = 3/22/2019	DATE -	REVISED -

**STATE OF ILLINOIS
DEPARTMENT OF TRANSPORTATION**

SCHEDULE OF QUANTITIES

SCALE: SHEET 17 OF 19 SHEETS STA. TO STA.

F.A.P. RTE.	SECTION	COUNTY	TOTAL SHEETS	SHEET NO.
836	**	-	214	33
CONTRACT NO. 70D56				

SCHEDULE OF QUANTITIES

GRADING AND SHAPING SCHEDULE							
NORTHTBOUND LANE							
STATION	TO	STATION	LENGTH FOOT	REASON FOR STATION BREAK	HSIP		
					CHAMPAIGN VERMILION		GRADING AND SHAPING SHOULDERS SPECIAL FOOT
					X0327584		
					FOOT		
321+00.00	TO	333+49.64	1,249.64	MAINLINE			1,249.7
333+49.64	TO	333+81.38	31.74	FE			
333+81.38	TO	345+03.13	1,121.75	MAINLINE			1,121.8
345+03.13	TO	345+32.53	29.40	FE			
345+32.53	TO	360+22.63	1,490.10	MAINLINE			1,490.1
360+22.63	TO	360+57.39	34.76	FE			
360+57.39	TO	373+53.08	1,295.69	MAINLINE			1,295.7
373+53.08	TO	373+96.85	43.77	E 200 NORTH RD			
373+96.85	TO	387+08.67	1,311.82	MAINLINE			1,311.9
387+08.67	TO	387+47.07	38.40	FE			
387+47.07	TO	399+85.77	1,238.70	MAINLINE			1,238.7
399+85.77	TO	400+23.49	37.72	FE			
400+23.49	TO	405+21.52	498.03	MAINLINE			498.1
405+21.52	TO	405+61.34	39.82	PE			
405+61.34	TO	408+63.73	302.39	MAINLINE			302.4
408+63.73	TO	408+91.76	28.03	PE			
408+91.76	TO	418+72.85	981.09	MAINLINE			981.1
418+72.85	TO	419+56.93	84.08	PE			
419+56.93	TO	420+29.01	72.08	MAINLINE			72.1
420+29.01	TO	420+85.98	56.97	PE			
420+85.98	TO	421+77.05	91.07	MAINLINE			91.1
421+77.05	TO	422+08.42	31.37	MAINLINE	31.4		
				ENGLISH ST +			
422+08.42	TO	423+27.19	118.77	CR 2800E			
423+27.19	TO	427+38.42	411.23	MAINLINE	411.3		
427+38.42	TO	428+71.54	133.12	E. YATES ST.			
428+71.54	TO	429+71.00	99.46	MAINLINE	99.5		
429+71.00	TO	430+24.38	53.38	FE			
430+24.38	TO	450+83.04	2,058.66	MAINLINE	2,058.7		
450+83.04	TO	451+29.66	46.62	FE			
451+29.66	TO	479+17.96	2,788.30	MAINLINE	2,788.3		
479+17.96	TO	479+58.82	40.86	FE			
479+58.82	TO	486+04.93	646.11	MAINLINE	646.2		
486+04.93	TO	486+68.95	64.02	PE			
486+68.95	TO	492+25.76	556.81	MAINLINE	556.9		
492+25.76	TO	492+63.82	38.06	FE			
492+63.82	TO	501+27.89	864.07	MAINLINE	864.1		
501+27.89	TO	501+55.70	27.81	FE			
501+55.70	TO	505+37.16	381.46	MAINLINE	381.5		
505+37.16	TO	505+65.96	28.80	PE			
505+65.96	TO	506+45.55	79.59	MAINLINE	79.6		
506+45.55	TO	506+78.32	32.77	PE			
506+78.32	TO	513+33.37	655.05	MAINLINE	655.1		
513+33.37	TO	513+79.31	45.94	FE			
513+79.31	TO	514+50.97	71.66	MAINLINE	71.7		
514+50.97	TO	514+81.52	30.55	PE			
514+81.52	TO	522+06.44	724.92	MAINLINE	725.0		
522+06.44	TO	522+37.98	31.54	FE			
522+37.98	TO	531+72.54	934.56	MAINLINE	934.6		
531+72.54	TO	532+17.66	45.12	CR 300N			
532+17.66	TO	544+95.49	1,277.83	MAINLINE	1,277.9		
544+95.49	TO	545+16.20	20.71	FE			
545+16.20	TO	544+68.87	-47.33	MAINLINE	-47.4		
544+68.87	TO	554+80.35	1,011.48	FE			
554+80.35	TO	564+93.14	1,012.79	MAINLINE	1,012.8		
564+93.14	TO	565+09.83	16.69	FE			
565+09.83	TO	571+34.09	624.26	MAINLINE	624.3		
571+34.09	TO	571+77.00	42.91	CR 375N			
571+77.00	TO	578+57.01	680.01	MAINLINE	680.1		
578+57.01	TO	578+79.22	22.21	FE			
578+79.22	TO	584+66.53	587.31	MAINLINE	587.4		
SCHEDULE BREAK SUB-TOTALS =					14,439.0		9,652.7

GRADING AND SHAPING SCHEDULE							
NORTHTBOUND LANE							
STATION	TO	STATION	LENGTH FOOT	REASON FOR STATION BREAK	HSIP		
					CHAMPAIGN VERMILION		GRADING AND SHAPING SHOULDERS SPECIAL FOOT
					X0327584		
					FOOT		
584+66.53	TO	584+84.37	17.84	FE			
584+84.37	TO	595+38.42	1,054.05	MAINLINE			1,054.1
595+38.42	TO	595+65.04	26.62	PE			
595+65.04	TO	597+94.32	229.28	MAINLINE			229.3
597+94.32	TO	598+19.30	24.98	FE			
598+19.30	TO	601+09.03	289.73	MAINLINE			289.8
601+09.03	TO	601+41.59	32.56	FE			
601+41.59	TO	611+29.75	988.16	MAINLINE			988.2
611+29.75	TO	611+45.96	16.21	FE			
611+45.96	TO	624+53.59	1,307.63	MAINLINE			1,307.7
624+53.59	TO	624+69.51	15.92	FE			
624+69.51	TO	637+58.02	1,288.51	MAINLINE			1,288.6
637+58.02	TO	638+07.88	49.86	CR 500N			
638+07.88	TO	646+13.68	805.80	MAINLINE			805.9
646+13.68	TO	646+80.39	66.71	PE			
646+80.39	TO	651+32.64	452.25	MAINLINE			452.3
651+32.64	TO	651+44.24	11.60	FE			
651+44.24	TO	663+33.37	1,189.13	MAINLINE			1,189.2
				FE +			
663+33.37	TO	665+01.19	167.82	SN 010-0236			
665+01.19	TO	677+25.53	1,224.34	MAINLINE			1,224.4
677+25.53	TO	677+38.04	12.51	FE			
677+38.04	TO	686+75.09	937.05	MAINLINE			937.1
				FE +			
686+75.09	TO	690+77.85	402.76	SN 01-0284			
690+77.85	TO	690+91.60	13.75	MAINLINE			13.8
690+91.60	TO	691+09.88	18.28	FE			
691+09.88	TO	705+39.05	1,429.17	MAINLINE			1,429.2
705+39.05	TO	705+76.87	37.82	PE			
705+76.87	TO	729+30.49	2,353.62	MAINLINE			2,353.7
729+30.49	TO	729+66.49	36.00	SN 010-0269			
729+66.49	TO	730+82.77	116.28	MAINLINE			116.3
730+82.77	TO	731+20.00	37.23	FE			
731+20.00	TO	743+02.14	1,182.14	MAINLINE			1,182.2
743+02.14	TO	743+24.12	21.98	FE			
743+24.12	TO	743+98.06	73.94	MAINLINE			74.0
743+98.06	TO	744+56.62	58.56	CR 700N			
744+56.62	TO	761+09.30	1,652.68	MAINLINE			1,652.7
761+09.30	TO	761+18.78	9.48	FE			
761+18.78	TO	770+09.71	890.93	MAINLINE			891.0
770+09.71	TO	770+44.05	34.34	FE			
770+44.05	TO	772+08.38	164.33	MAINLINE			164.4
772+08.38	TO	772+43.27	34.89	PE			
772+43.27	TO	783+87.72	1,144.45	MAINLINE			1,144.5
783+87.72	TO	784+16.69	28.97	FE			
784+16.69	TO	797+00.19	1,283.50	MAINLINE			1,283.5
797+00.19	TO	797+51.25	51.06	CR 800N			
797+51.25	TO	812+91.02	1,539.77	MAINLINE			1,539.8
812+91.02	TO	813+08.72	17.70	FE			
813+08.72	TO	848+05.67	3,496.95	MAINLINE			3,497.0
848+05.67	TO	848+41.48	35.81	PE			
848+41.48	TO	865+25.69	1,684.21	MAINLINE			1,684.3
865+25.69	TO	865+56.32	30.63	PE			
865+56.32	TO	876+49.16	1,092.84	MAINLINE			1,092.9
876+49.16	TO	876+60.03	10.87	FE			
876+60.03	TO	891+74.93	1,514.90	MAINLINE			1,514.9
891+74.93	TO	891+83.81	8.88	FE			
891+83.81	TO	901+49.17	965.36	MAINLINE			965.4
901+49.17	TO	901+91.17	42.00	FE			
901+91.17	TO	903+06.96	115.79	MAINLINE			115.8
903+06.96	TO	903+82.91	75.95	FE			
NORTHBOUND TOTALS =					44,921.0		9,652.7

X0327584 CONTINUES ON SHEET: 35

MODEL: 4\MODEL\M1\F15
FILE: M1\F15\118RS-3_119RS-4.D5\HSP1019-1\Schedule.dgn

USER NAME = PiersonTJ	DESIGNED -	REVISED -
	DRAWN -	REVISED -
PLOT SCALE = 40.0000 ' / in.	CHECKED -	REVISED -
PLOT DATE = 3/22/2019	DATE -	REVISED -

**STATE OF ILLINOIS
DEPARTMENT OF TRANSPORTATION**

SCHEDULE OF QUANTITIES

SCALE: SHEET 18 OF 19 SHEETS STA. TO STA.

F.A.P. RTE.	SECTION	COUNTY	TOTAL SHEETS	SHEET NO.
836	**	-	214	34
CONTRACT NO. 70D56				

SCHEDULE OF QUANTITIES

GRADING AND SHAPING SCHEDULE						
SOUTHBOUND LANE						
STATION	TO	STATION	LENGTH FOOT	REASON FOR STATION BREAK	HSIP	
					CHAMPAIGN	VERMILION
					X0327584	
GRADING AND SHAPING SHOULDERS SPECIAL						
FOOT						
321+00.00	TO	331+01.46	1,001.46	MAINLINE		1,001.5
331+01.46	TO	331+34.35	32.89	FE		
331+34.35	TO	338+01.81	667.46	MAINLINE		667.5
338+01.81	TO	338+38.93	37.12	FE		
338+38.93	TO	342+68.03	429.10	MAINLINE		429.1
342+68.03	TO	343+40.43	72.40	PE		
343+40.43	TO	346+83.63	343.20	MAINLINE		343.2
346+83.63	TO	347+23.21	39.58	FE		
347+23.21	TO	354+34.56	711.35	MAINLINE		711.4
354+34.56	TO	354+99.14	64.58	PE		
354+99.14	TO	356+88.08	188.94	MAINLINE		189.0
356+88.08	TO	357+26.99	38.91	PE		
357+26.99	TO	371+98.03	1,471.04	MAINLINE		1,471.1
371+98.03	TO	372+33.44	35.41	FE		
372+33.44	TO	373+19.10	85.66	MAINLINE		85.7
373+19.10	TO	374+01.13	82.03	FE+ CR 100N		
374+01.13	TO	386+92.11	1,290.98	MAINLINE		1,291.0
386+92.11	TO	387+28.15	36.04	FE		
387+28.15	TO	399+76.52	1,248.37	MAINLINE		1,248.4
399+76.52	TO	400+12.54	36.02	FE		
400+12.54	TO	413+41.26	1,328.72	MAINLINE		1,328.8
413+41.26	TO	413+61.84	20.58	FE		
413+61.84	TO	421+77.05	815.21	MAINLINE		815.3
421+77.05	TO	450+41.00	2,863.95	MAINLINE	2,864.0	
450+41.00	TO	450+91.64	50.64	FE		
450+91.64	TO	463+47.40	1,255.76	MAINLINE	1,255.8	
463+47.40	TO	463+93.47	46.07	FE		
463+93.47	TO	477+67.24	1,373.77	MAINLINE	1,373.8	
477+67.24	TO	479+16.09	148.85	BROADLANDS RD		
479+16.09	TO	479+24.31	8.22	MAINLINE	8.3	
479+24.31	TO	479+63.88	39.57	FE		
479+63.88	TO	486+16.97	653.09	MAINLINE	653.1	
486+16.97	TO	486+50.33	33.36	FE		
486+50.33	TO	500+92.79	1,442.46	MAINLINE	1,442.5	
500+92.79	TO	501+57.55	64.76	PE		
501+57.55	TO	505+34.09	376.54	MAINLINE	376.6	
505+34.09	TO	505+68.85	34.76	FE		
505+68.85	TO	514+51.16	882.31	MAINLINE	882.4	
514+51.16	TO	514+82.13	30.97	FE		
514+82.13	TO	519+37.06	454.93	MAINLINE	455.0	
519+37.06	TO	519+72.61	35.55	PE		
519+72.61	TO	531+68.25	1,195.64	MAINLINE	1,195.7	
531+68.25	TO	532+22.00	53.75	CR 300N		
532+22.00	TO	545+05.37	1,283.37	MAINLINE	1,283.4	
545+05.37	TO	545+37.12	31.75	FE		
545+37.12	TO	558+08.42	1,271.30	MAINLINE	1,271.3	
558+08.42	TO	558+74.93	66.51	FE		
558+74.93	TO	571+28.76	1,253.83	MAINLINE	1,253.9	
571+28.76	TO	571+62.02	33.26	FE		
571+62.02	TO	580+04.44	842.42	MAINLINE	842.5	
580+04.44	TO	580+40.69	36.25	FE		
580+40.69	TO	584+54.68	413.99	MAINLINE	414.0	
584+54.68	TO	585+21.49	66.81	CR 400N		
585+21.49	TO	594+32.86	911.37	MAINLINE	911.4	
594+32.86	TO	595+03.21	70.35	PE		
595+03.21	TO	600+10.59	507.38	MAINLINE	507.4	
600+10.59	TO	600+40.95	30.36	PE		
600+40.95	TO	601+22.66	81.71	MAINLINE	81.8	
601+22.66	TO	601+58.02	35.36	FE		
SCHEDULE BREAK SUB-TOTALS =					17,072.9	9,582.0

GRADING AND SHAPING SCHEDULE						
SOUTHBOUND LANE						
STATION	TO	STATION	LENGTH FOOT	REASON FOR STATION BREAK	HSIP	
					CHAMPAIGN	VERMILION
					X0327584	
GRADING AND SHAPING SHOULDERS SPECIAL						
FOOT						
601+58.02	TO	612+89.48	1,131.46	MAINLINE		1,131.5
612+89.48	TO	613+18.33	28.85	FE		
613+18.33	TO	624+31.05	1,112.72	MAINLINE		1,112.8
624+31.05	TO	624+61.66	30.61	FE		
624+61.66	TO	637+48.36	1,286.70	MAINLINE		1,286.7
637+48.36	TO	638+02.31	53.95	CR 500N		
638+02.31	TO	652+63.38	1,461.07	MAINLINE		1,461.1
652+63.38	TO	653+01.21	37.83	PE		
653+01.21	TO	664+09.01	1,107.80	MAINLINE		1,107.8
664+09.01	TO	667+63.37	354.36	SN 010-0236		
667+63.37	TO	676+75.79	912.42	MAINLINE		912.5
676+75.79	TO	677+18.90	43.11	FE		
677+18.90	TO	678+76.62	157.72	MAINLINE		157.8
678+76.62	TO	679+17.76	41.14	PE		
679+17.76	TO	686+75.73	757.97	MAINLINE		758.0
686+75.73	TO	691+66.24	490.51	SN 010-0284 + CR		
691+66.24	TO	701+39.52	973.28	600N MAINLINE		973.3
701+39.52	TO	701+88.27	48.75	FE		
701+88.27	TO	729+30.45	2,742.18	MAINLINE		2,742.2
729+30.45	TO	731+64.56	234.11	SN 010-0269		
731+64.56	TO	744+00.86	1,236.30	MAINLINE		1,236.3
744+00.86	TO	744+55.64	54.78	CR 700N		
744+55.64	TO	759+23.89	1,468.25	MAINLINE		1,468.3
759+23.89	TO	759+60.02	36.13	PE		
759+60.02	TO	767+96.28	836.26	MAINLINE		836.3
767+96.28	TO	768+42.91	46.63	PE		
768+42.91	TO	770+63.61	220.70	MAINLINE		220.7
770+63.61	TO	771+04.34	40.73	FE		
771+04.34	TO	777+17.49	613.15	MAINLINE		613.2
777+17.49	TO	777+91.10	73.61	FE		
777+91.10	TO	797+04.01	1,912.91	MAINLINE		1,913.0
797+04.01	TO	797+51.85	47.84	CR 800N		
797+51.85	TO	801+77.11	425.26	MAINLINE		425.3
801+77.11	TO	802+11.54	34.43	FE		
802+11.54	TO	813+47.97	1,136.43	MAINLINE		1,136.5
813+47.97	TO	813+84.24	36.27	FE		
813+84.24	TO	847+92.75	3,408.51	MAINLINE		3,408.6
847+92.75	TO	848+59.65	66.90	PE		
848+59.65	TO	849+90.16	130.51	MAINLINE		130.6
849+90.16	TO	850+43.53	53.37	CR 900N		
850+43.53	TO	856+65.63	622.10	MAINLINE		622.2
856+65.63	TO	857+00.40	34.77	FE		
857+00.40	TO	858+32.37	131.97	MAINLINE		132.0
858+32.37	TO	859+13.53	81.16	PE		
859+13.53	TO	860+97.17	183.64	MAINLINE		183.7
860+97.17	TO	861+36.83	39.66	FE		
861+36.83	TO	864+05.84	269.01	MAINLINE		269.1
864+05.84	TO	864+33.45	27.61	FE		
864+33.45	TO	876+24.60	1,191.15	MAINLINE		1,191.2
876+24.60	TO	876+68.15	43.55	FE		
876+68.15	TO	889+43.13	1,274.98	MAINLINE		1,275.0
889+43.13	TO	889+78.56	35.43	FE		
889+78.56	TO	893+95.86	417.30	MAINLINE		417.4
893+95.86	TO	894+25.67	29.81	FE		
894+25.67	TO	902+24.40	798.73	MAINLINE		798.8
902+24.40	TO	902+76.16	51.76	FE		
902+76.16	TO	903+82.91	106.75	MAINLINE		106.8
SOUTHBOUND SUB-TOTALS =					45,101.6	9,582.0
SUB-TOTALS =					90,022.6	19,234.7
ROUNDED SUB-TOTALS =					90,023.0	19,235.0
TOTALS =					109,258.0	

X0327584 CONTINUES ON SHEET: 34

MODEL: I:\MODEL\MRHS
FILE: MRHS - Proj\Illinois\0056\DWG\Drawn\0056\HSIP-Schedule.dwg

USER NAME = PiersonTJ	DESIGNED -	REVISIONS -
	DRAWN -	REVISIONS -
PLOT SCALE = 40.0000' / in.	CHECKED -	REVISIONS -
PLOT DATE = 3/22/2019	DATE -	REVISIONS -

**STATE OF ILLINOIS
DEPARTMENT OF TRANSPORTATION**

SCHEDULE OF QUANTITIES

SCALE: SHEET 19 OF 19 SHEETS STA. TO STA.

F.A.P. RTE.	SECTION	COUNTY	TOTAL SHEETS	SHEET NO.
836	**	-	214	35
CONTRACT NO. 70D56				

**118RS-3.118RS-4.D5 HSIP 2019-1 *CHAMPAIGN & VERMILION

CONTROL POINTS

CENTERLINE CONTROL POINTS

POINT	DESC.	NORTHING	EASTING	STATION	OFFSET	COMMENT
5047_ALL ALIGNMENT						
TDL1	CALC POT	1051700.185	1095264.950	0+00.00	0.00	NOT SET (USED FOR STATIONING) OUTSIDE SURVEY LIMITS
1	PI	1057187.912	1095137.156	56+97.80	2.90	MAG NAIL SET
5	PI	1064830.117	1094868.915	133+44.69	-3.39	MAG NAIL SET
B105	STA EQ	1070598.478	1094747.984	191+14.30	0.00	MAG NAIL SET (191+11.74AH)
10	PI	1072821.735	1094701.374	212+76.32	-165.39	EXISTING I.P. FOUND (213+35.49)
13	PI	1073439.976	1095798.093	224+55.71	79.55	EXISTING I.P. FOUND (224+76.14)
PCC15	PCC	1073830.510	1095912.670	228+42.28	0.00	MAG NAIL SET
15	PI	1074158.678	1096008.953	231+81.72	25.74	EXISTING I.P. FOUND
B106	STA EQ	1075863.904	1095983.274	248+84.56	0.00	MAG NAIL SET (246+78.52AH)
20	PI KINK	1083315.491	1095871.062	321+30.95	0.00	EXISTING DISK FOUND
24	PI	1095406.508	1095693.499	442+23.27	0.31	MAG NAIL FOUND
29	PI	1105009.698	1095548.088	538+27.42	7.34	MAG NAIL SET (538+27.56)
101	PI	1106120.577	1095465.902	549+41.08	-6.45	MAG NAIL SET (549+41.19)
34	PI KINK	1110464.233	1095369.257	592+85.70	0.00	EXISTING VAULT ALSO = SECTION CORNER #202
36	PI	1115641.956	1095256.186	644+64.66	-0.99	MAG NAIL SET
102	PI	1126591.429	1095060.538	754+15.88	0.42	MAG NAIL SET
B45	POT	1138518.274	1094827.232	873+45.00	0.00	DISK-STATION EQ. BACK (B45=A45)
5045_2 ALIGNMENT						
A45	POT	1138518.274	1094827.232	0+00.00	0.00	DISK-STATION EQ. AHEAD (A45=B45)
103	PI	1139120.247	1094815.457	5+85.53	-71.22	I.P. SET
104	PI	1140117.224	1095620.700	18+34.56	69.62	EXISTING I.P. FOUND
105	PI	1161908.434	1095404.980	236+10.87	0.65	MAG NAIL SET
106	PI	1180929.383	1095167.173	425+26.01	207.10	MAG NAIL SET (ON PAVEMENT OF COUNTY ROAD)
68	PI KINK	1180900.429	1092838.868	447+47.21	0.00	MAG NAIL SET
107	PI	1180868.817	1090700.564	468+81.83	26.02	DRILL HOLE IN OLD CONC. PAVEMENT
108	PI	1180446.418	1089862.382	476+37.65	-269.57	MAG NAIL SET (ON PAVEMENT OF COUNTY ROAD)
88	PI KINK	1200737.272	1089636.710	677+50.91	0.00	EXISTING I.P. FOUND
89	PI	1202461.214	1089618.132	694+74.83	6.82	MAG NAIL SET
PRC109	PRC	1202958.950	1089585.510	699+73.51	0.00	MAG NAIL SET
109	PI	1203651.630	1089540.116	706+67.47	-10.27	MAG NAIL SET
110	PI	1213103.051	1089480.710	801+18.87	1.08	MAG NAIL SET
100	POT	1224642.086	1089358.460	916+58.55	0.00	EXISTING MAG NAIL FOUND (OUTSIDE SURVEY LIMITS)

TRAVERSE STATIONS

POINT	NORTHING	EASTING	ELEVATION	STATION	OFFSET
501	1,138,661.971	1,094,760.050	657.049	1+44.99	-64.36
502	1,180,847.931	1,089,923.075	692.405	678+40.62	50.43
503	1,201,723.921	1,089,657.147	677.613	687+37.28	31.07

MODEL: \\MODEL\MAPS
 FILE: \\maps\p\118056\CADD\Drawings\DOT_Offices\Drawings\5045_2\5045_2-ht-Control Points.dgn

USER NAME = PiersonTJ	DESIGNED -	REVISED -	STATE OF ILLINOIS DEPARTMENT OF TRANSPORTATION	CONTROL POINTS			F.A.P. RTE.	SECTION	COUNTY	TOTAL SHEETS	SHEET NO.
	DRAWN -	REVISED -					836	**	-	214	36
PLOT SCALE = 40,0000' / in.	CHECKED -	REVISED -		SCALE:			CONTRACT NO. 70D56				
PLOT DATE = 3/22/2019	DATE -	REVISED -		SHEET 1	OF 1	SHEETS	STA.	TO STA.	ILLINOIS	FED. AID PROJECT	**118RS-3,119RS-4,D5 HSIP 2019-1

*CHAMPAIGN & VERMILION

SEC 33, T 16 N, R 14 W, 3RD PM



- HMA SURFACE REMOVAL, SPECIAL & INCIDENTAL HMA SURFACE
- PAVEMENT REMOVAL

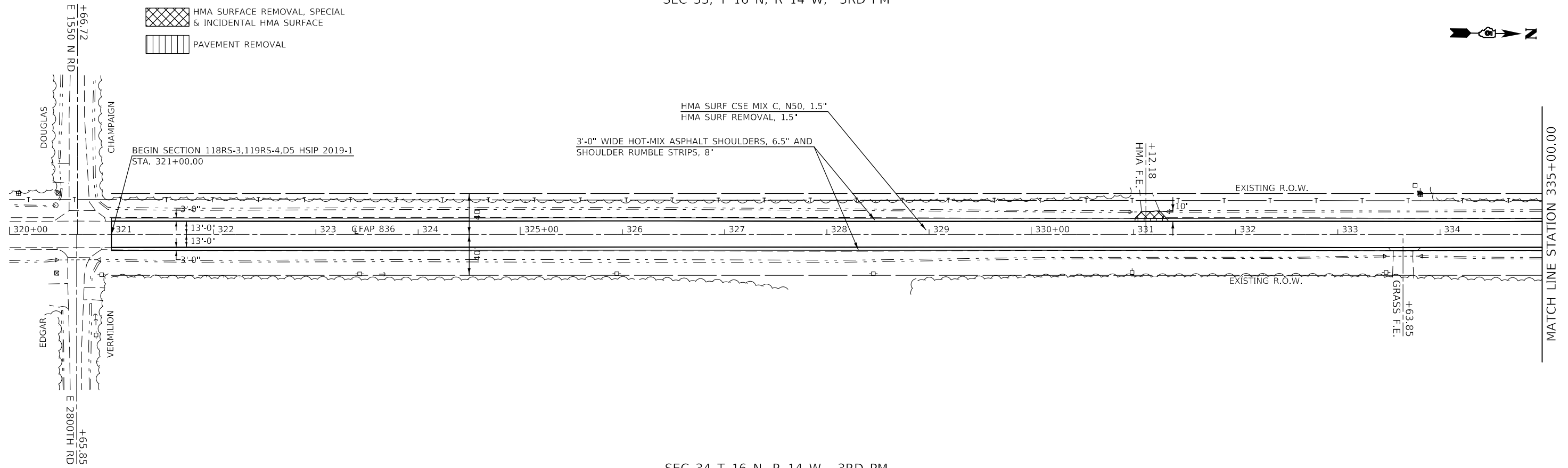

SEC 34 T 16 N, R 14 W, 3RD PM

SEC 33, T 16 N, R 14 W, 3RD PM



- HMA SURFACE REMOVAL, SPECIAL & INCIDENTAL HMA SURFACE
- PAVEMENT REMOVAL

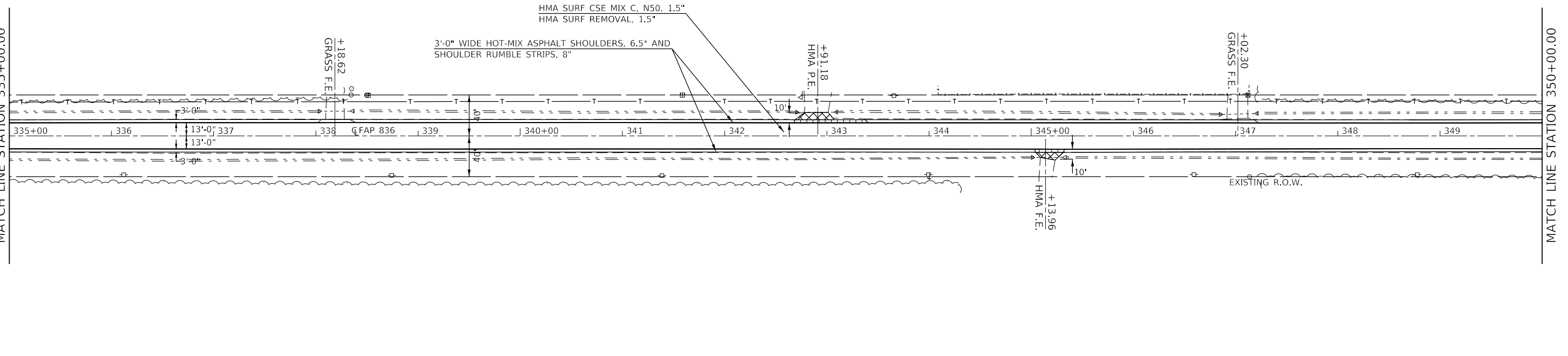

SEC 34 T 16 N, R 14 W, 3RD PM

MODEL: \\MODEL\MHFS
FILE: \\MHFS_Plan\118RS-3,119RS-4,D5 HSIP 2019-1\DOT Office\118RS-3,119RS-4,D5 HSIP 2019-1\Plan_Sheet_30_Scale_Sec 1.dgn

USER NAME = PiersonTJ	DESIGNED -	REVISED -
PLOT SCALE = 100.0000' / in.	DRAWN -	REVISED -
PLOT DATE = 4/3/2019	CHECKED -	REVISED -
	DATE -	REVISED -



**STATE OF ILLINOIS
DEPARTMENT OF TRANSPORTATION**

IL-49 PLAN SHEETS

SCALE: 1" = 50' SHEET 1 OF 21 SHEETS STA. 320+00.00 TO STA. 350+00.00

F.A.P. RTE.	SECTION	COUNTY	TOTAL SHEETS	SHEET NO.
836	**	-	214	37
CONTRACT NO. 70D56				

SEC 33, T 16 N, R 14 W, 3RD PM

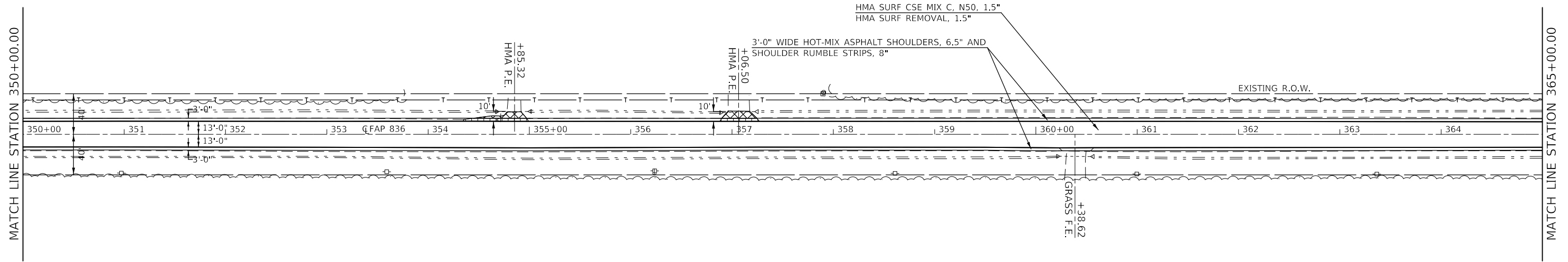

-  HMA SURFACE REMOVAL, SPECIAL & INCIDENTAL HMA SURFACE
-  PAVEMENT REMOVAL



SEC 34 T 16 N, R 14 W, 3RD PM

SEC 33, T 16 N, R 14 W, 3RD PM

SEC 28, T 16 N, R 14 W, 3RD PM

-  HMA SURFACE REMOVAL, SPECIAL & INCIDENTAL HMA SURFACE
-  PAVEMENT REMOVAL
-  HMA SURFACE COURSE INLAY ON EXISTING HMA SHOULDER

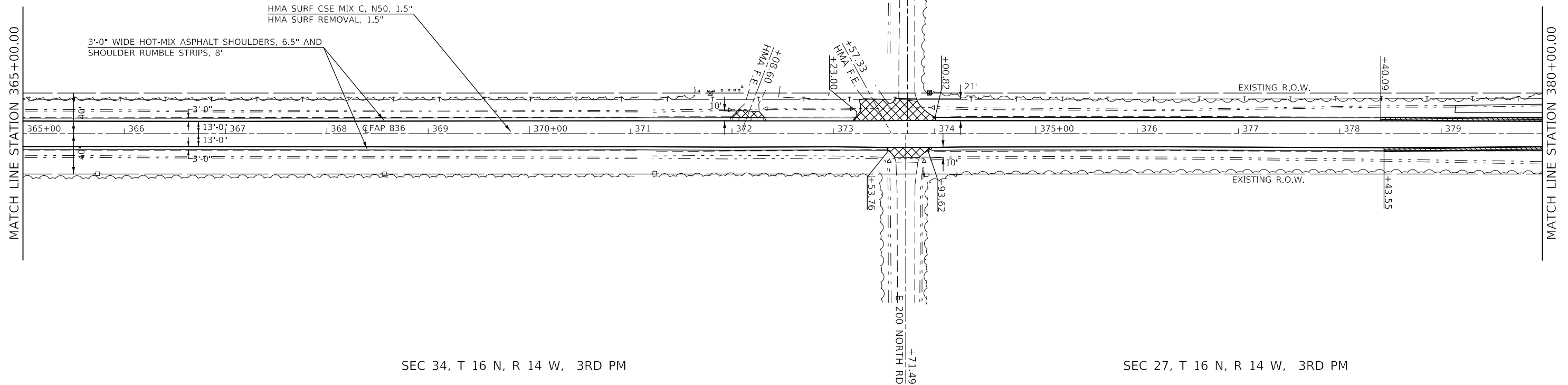

SEC 34, T 16 N, R 14 W, 3RD PM

SEC 27, T 16 N, R 14 W, 3RD PM

MODEL: \\MODEL\MARIS
 FILE: \\MARIS_Plan\p118rs-3,119rs-4,05\Drawings\70D56-Pln-Sheet-30_Scale_Sec-1.dgn

USER NAME = PiersonTJ	DESIGNED -	REVISED -
	DRAWN -	REVISED -
PLOT SCALE = 100.0000' / in.	CHECKED -	REVISED -
PLOT DATE = 4/3/2019	DATE -	REVISED -

**STATE OF ILLINOIS
DEPARTMENT OF TRANSPORTATION**

IL-49 PLAN SHEETS

SCALE: 1" = 50' SHEET 2 OF 21 SHEETS STA. 350+00.00 TO STA. 380+00.00

F.A.P. RTE.	SECTION	COUNTY	TOTAL SHEETS	SHEET NO.
836	**	-	214	38
CONTRACT NO. 70D56				

**118RS-3,119RS-4,05 HSIP 2019-1

*CHAMPAIGN & VERMILION

SEC 28, T 16 N, R 14 W, 3RD PM



HMA SURFACE COURSE INLAY ON EXISTING HMA SHOULDER

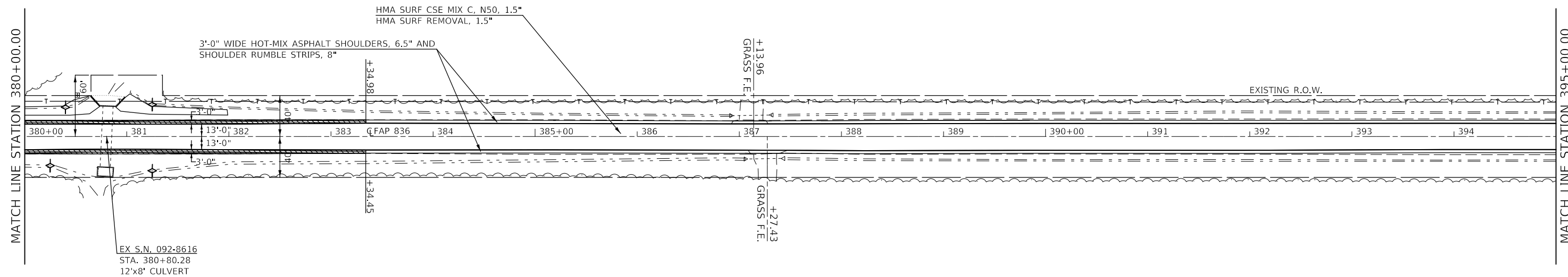

SEC 27 T 16 N, R 14 W, 3RD PM

SEC 28, T 16 N, R 14 W, 3RD PM



HMA SURFACE REMOVAL, SPECIAL & INCIDENTAL HMA SURFACE
 PAVEMENT REMOVAL

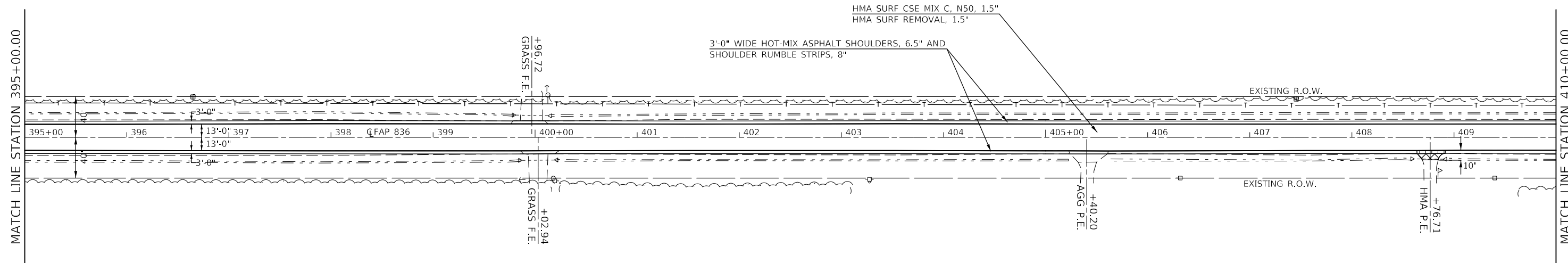

SEC 27 T 16 N, R 14 W, 3RD PM

MODEL: \\MODEL\MARKS
 FILE: MARKS_Plan\Illinois\pwr\PROJECTS\DOT\Offices\District 5\Projects\057005\05\AddData\Design\057005\5e-pln-Sheet_30_Scale_Set_1.dgn

USER NAME = PiersonTJ	DESIGNED -	REVISED -
	DRAWN -	REVISED -
PLOT SCALE = 100,0000' / in.	CHECKED -	REVISED -
PLOT DATE = 4/3/2019	DATE -	REVISED -

**STATE OF ILLINOIS
 DEPARTMENT OF TRANSPORTATION**

IL-49 PLAN SHEETS

SCALE: 1" = 50' SHEET 3 OF 21 SHEETS STA. 380+00.00 TO STA. 410+00.00

F.A.P. RTE.	SECTION	COUNTY	TOTAL SHEETS	SHEET NO.
836	**	-	214	39
CONTRACT NO. 70D56				

SEC 28, T 16 N, R 14 W, 3RD PM

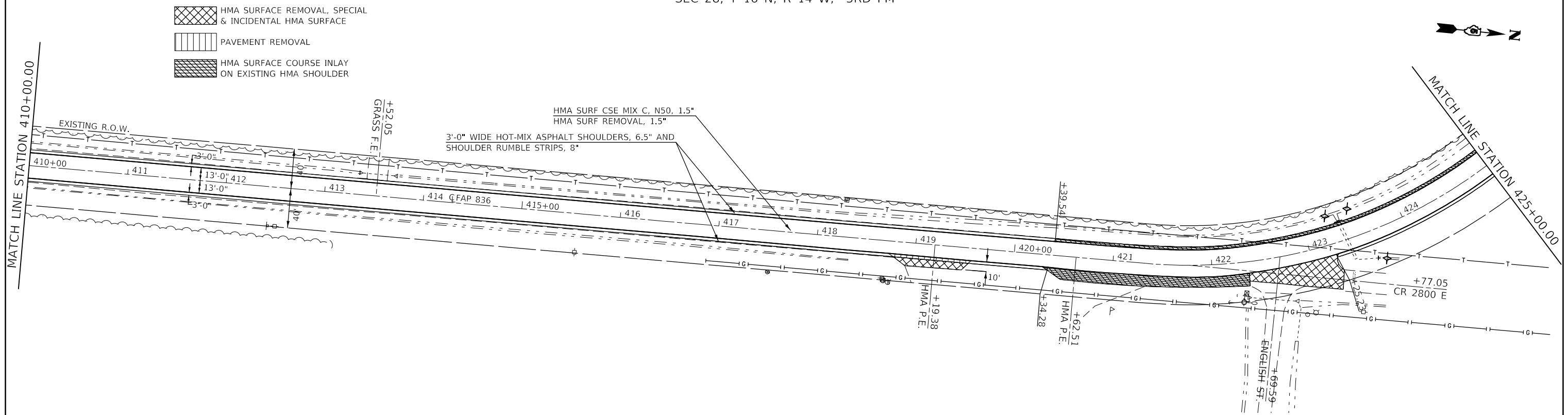

SEC 27 T 16 N, R 14 W, 3RD PM

SEC 28, T 16 N, R 14 W, 3RD PM

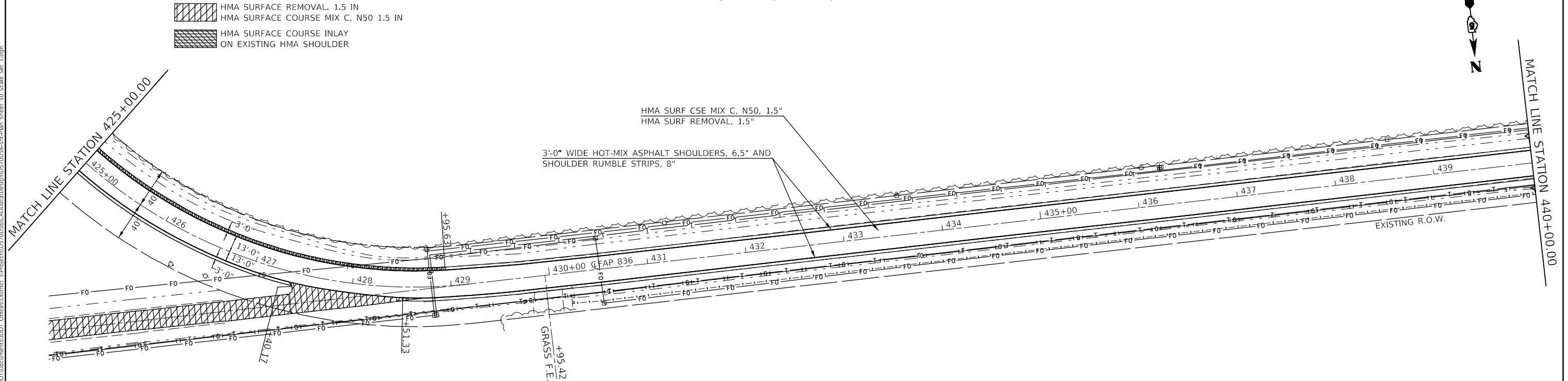

SEC 21 T 16 N, R 14 W, 3RD PM

MODEL: \\MODEL\MAINT
FILE: \\MAINT\proj\118rs-3\119rs-4\Design\0570D56-Plan_Sheet_50_Scale_Sec_1.dgn

USER NAME = PiersonJ	DESIGNED -	REVISED -
	DRAWN -	REVISED -
PLOT SCALE = 100.0000' / in.	CHECKED -	REVISED -
PLOT DATE = 4/3/2019	DATE -	REVISED -

STATE OF ILLINOIS
DEPARTMENT OF TRANSPORTATION

IL-49 PLAN SHEETS

SCALE: 1" = 50' SHEET 4 OF 21 SHEETS STA. 410+00.00 TO STA. 440+00.00

F.A.P. RTE.	SECTION	COUNTY	TOTAL SHEETS	SHEET NO.
836	**	-	214	40
CONTRACT NO. 70D56				

SEC 28, T 16 N, R 14 W, 3RD PM

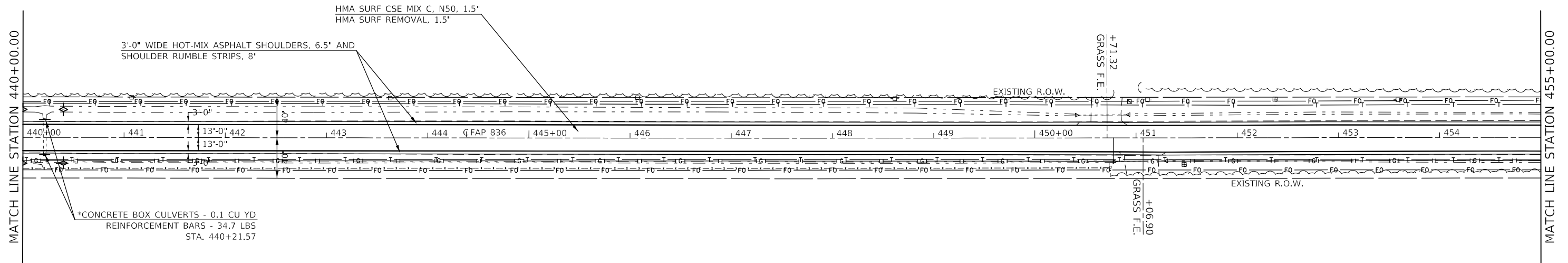

SEC 21 T 16 N, R 14 W, 3RD PM

* REMOVAL AND REERECTION OF DELINATOR AT CULVERT INCLUDED IN HEADWALL EXTENSION PAY ITEMS

SEC 28, T 16 N, R 14 W, 3RD PM



- PAVEMENT REMOVAL
- HMA SURFACE COURSE INLAY ON EXISTING HMA SHOULDER

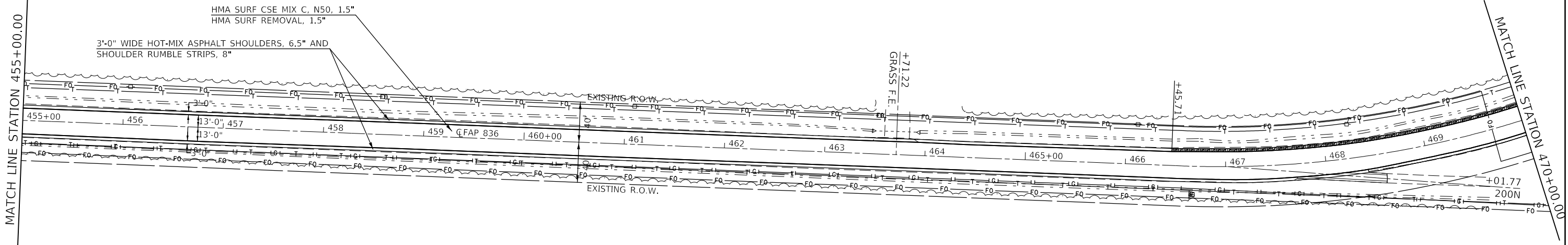

SEC 21 T 16 N, R 14 W, 3RD PM

MODEL: \\MODEL\MARTE
FILE: \\MARTE_Plan\Illinois\gov\PIWDOT\Documents\DOT_Offices\District 5\Projects\0570D56\0570D56\0570D56-Plan_Sheet_50_Scale_Sec 1.dgn

USER NAME = PiersonJ	DESIGNED -	REVISED -
PLOT SCALE = 100.0000' / in.	DRAWN -	REVISED -
PLOT DATE = 4/3/2019	CHECKED -	REVISED -
	DATE -	REVISED -



**STATE OF ILLINOIS
DEPARTMENT OF TRANSPORTATION**

IL-49 PLAN SHEETS

SCALE: 1" = 50' SHEET 5 OF 21 SHEETS STA. 440+00.00 TO STA. 470+00.00

F.A.P. RTE.	SECTION	COUNTY	TOTAL SHEETS	SHEET NO.
836	**	-	214	41
CONTRACT NO. 70D56				



-  PAVEMENT REMOVAL
-  HMA SURFACE REMOVAL, SPECIAL & INCIDENTAL HMA SURFACE
-  HMA SURFACE COURSE INLAY ON EXISTING HMA SHOULDER

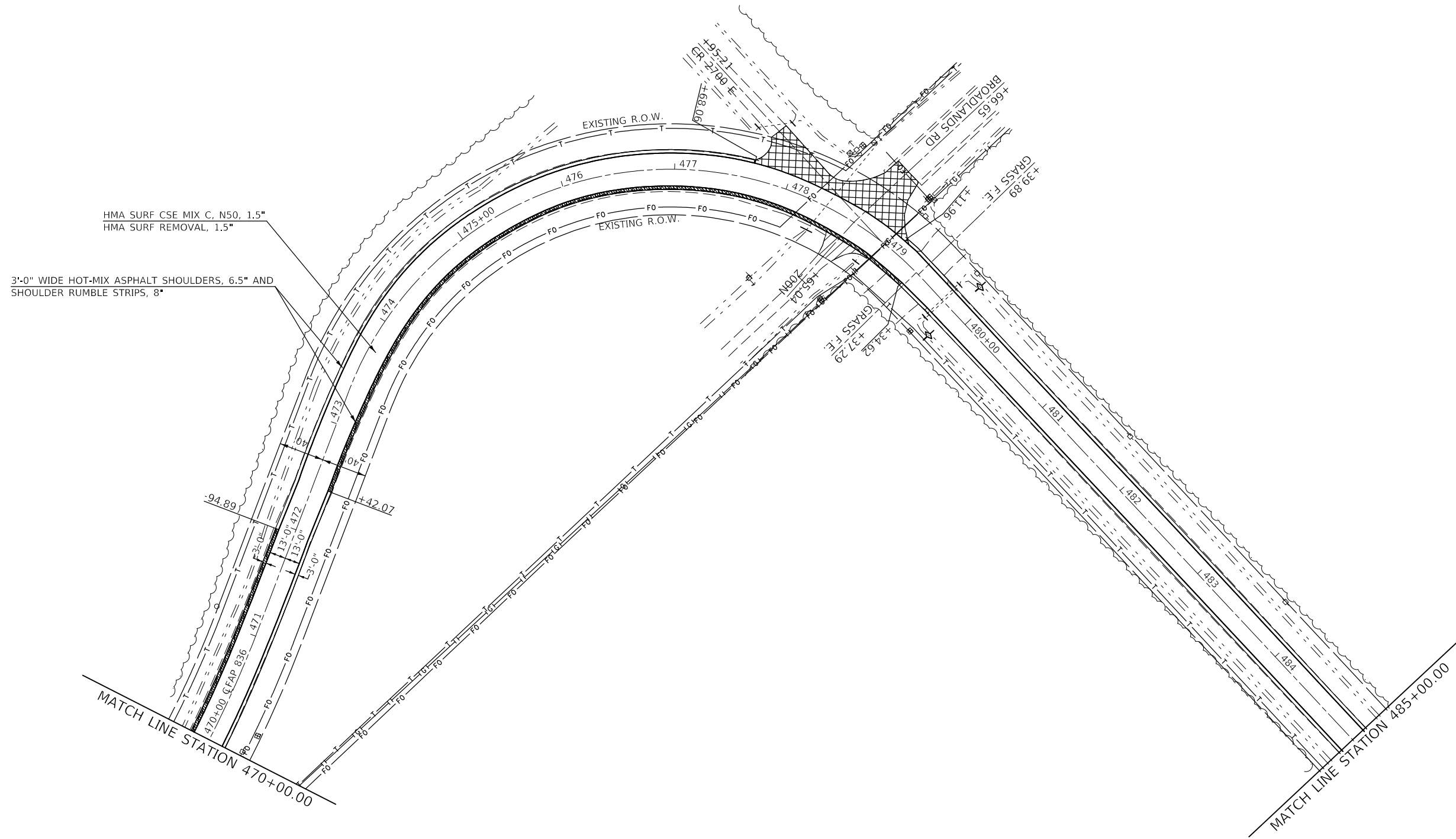

HMA SURF CSE MIX C. N50, 1.5"
HMA SURF REMOVAL, 1.5"

3'-0" WIDE HOT-MIX ASPHALT SHOULDERS, 6.5" AND
SHOULDER RUMBLE STRIPS, 8"

MODEL: \\MODEL\NAME
 FILE: \\name: p:\pub\mcom\m\dat\illinois.gov\PI\DOT\Documents\DOT_Offices\District 5\Projects\0570D56\CADD\Drawn\0570D56-HI-Plan_Sheet_50_Scale_Sec 1.dgn

USER NAME = PiersonTJ	DESIGNED -	REVISED -
	DRAWN -	REVISED -
PLOT SCALE = 100,0000' / in.	CHECKED -	REVISED -
PLOT DATE = 3/22/2019	DATE -	REVISED -



**STATE OF ILLINOIS
DEPARTMENT OF TRANSPORTATION**

IL-49 PLAN SHEETS

SCALE: 1" = 50' SHEET 6 OF 21 SHEETS STA. 470+00.00 TO STA. 485+00.00

F.A.P. RTE.	SECTION	COUNTY	TOTAL SHEETS	SHEET NO.
836	**	-	214	42
CONTRACT NO. 70D56				

SEC 20, T 16 N, R 14 W, 3RD PM

 HMA SURFACE REMOVAL, SPECIAL & INCIDENTAL HMA SURFACE
 PAVEMENT REMOVAL

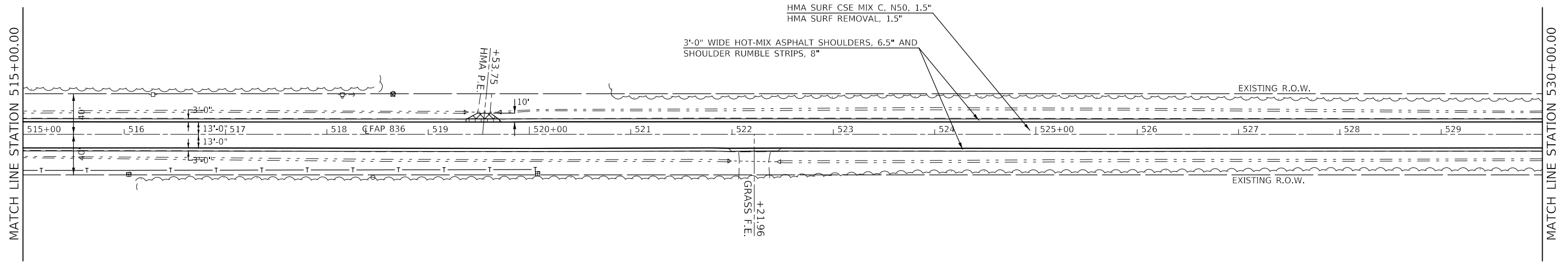

SEC 21 T 16 N, R 14 W, 3RD PM

SEC 17, T 17 N, R 14 W, 3RD PM

 HMA SURFACE REMOVAL, SPECIAL & INCIDENTAL HMA SURFACE

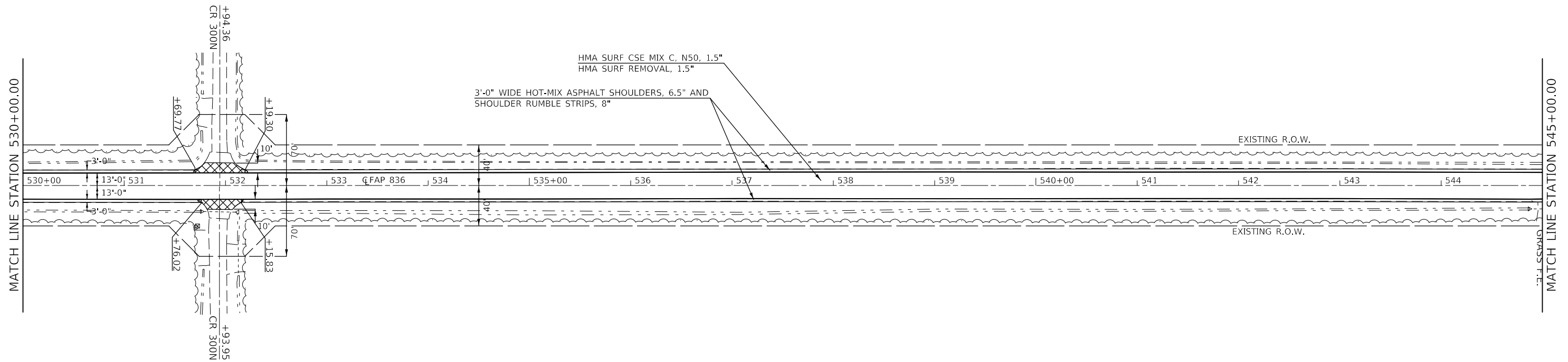

SEC 16 T 17 N, R 14 W, 3RD PM

MODEL: \\MODEL\MHFE
 FILE: \\MAILS_Plan\p118rs-3,119rs-4,05\hisp\2019-1\DOT\Office\Drawings\Projects\DOT\Office\Drawings\2019\545+00.00\Plan_Sheet_50_Scale_Sec_1.dgn

USER NAME = PiersonTJ	DESIGNED -	REVISED -
PLOT SCALE = 100.0000' / in.	DRAWN -	REVISED -
PLOT DATE = 4/3/2019	CHECKED -	REVISED -
	DATE -	REVISED -

STATE OF ILLINOIS
DEPARTMENT OF TRANSPORTATION

IL-49 PLAN SHEETS

SCALE: 1" = 50' SHEET 8 OF 21 SHEETS STA. 515+00.00 TO STA. 545+00.00

F.A.P. RTE.	SECTION	COUNTY	TOTAL SHEETS	SHEET NO.
836	**	-	214	44
CONTRACT NO. 70D56				

SEC 17, T 17 N, R 14 W, 3RD PM

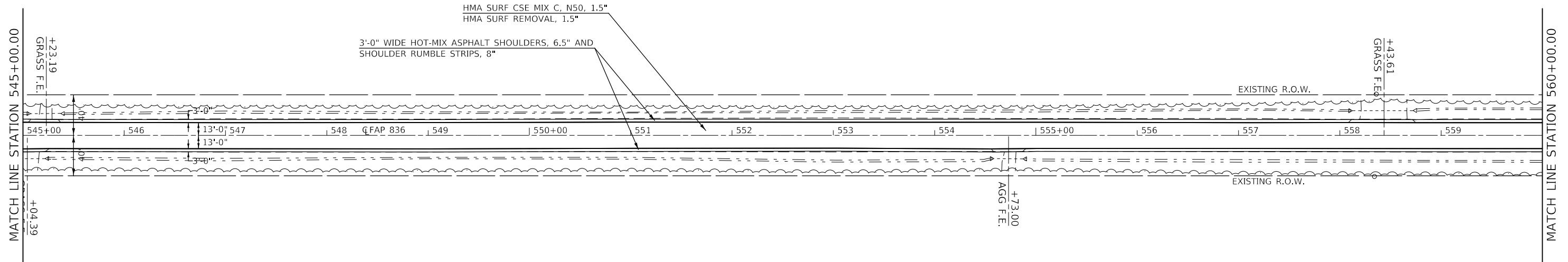

SEC 16 T 17 N, R 14 W, 3RD PM

SEC 17, T 17 N, R 14 W, 3RD PM



HMA SURFACE REMOVAL, SPECIAL & INCIDENTAL HMA SURFACE

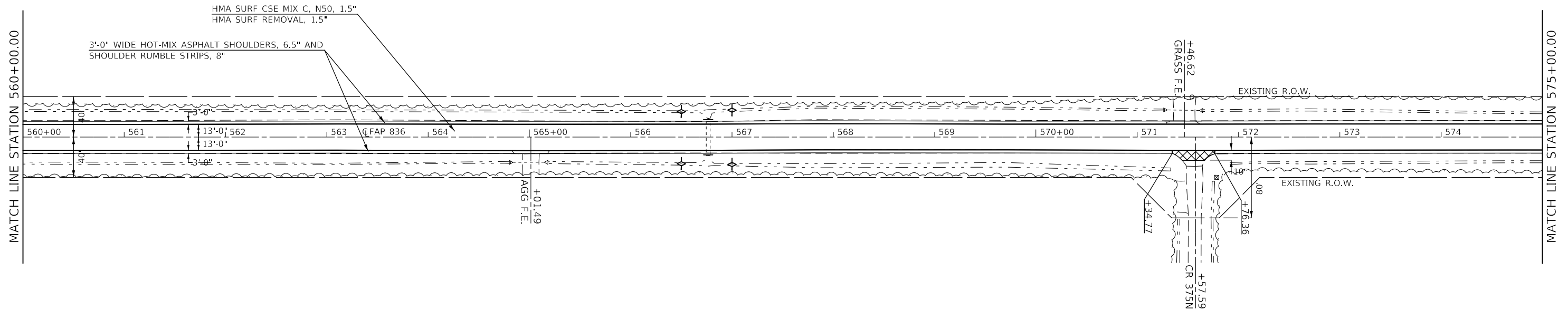

SEC 16 T 17 N, R 14 W, 3RD PM

MODEL: \\MODEL\MHFE
 FILE: \\MAILS_Plan\p118rs-3,119rs-4,05 HSIP 2019-1\Projects\DOT_Offices\District 5\Projects\0570D56\0570D56-Plan_Sheet_50_Scale_Sec 1.dgn

USER NAME = PiersonTJ	DESIGNED -	REVISED -
PLOT SCALE = 100,0000' / in.	DRAWN -	REVISED -
PLOT DATE = 4/3/2019	CHECKED -	REVISED -
	DATE -	REVISED -

**STATE OF ILLINOIS
DEPARTMENT OF TRANSPORTATION**

IL-49 PLAN SHEETS

SCALE: 1" = 50' SHEET 9 OF 21 SHEETS STA. 545+00.00 TO STA. 575+00.00

F.A.P. RTE.	SECTION	COUNTY	TOTAL SHEETS	SHEET NO.
836	**	-	214	45
CONTRACT NO. 70D56				

SEC 17, T 17 N, R 14 W, 3RD PM

SEC 8, T 17 N, R 14 W, 3RD PM

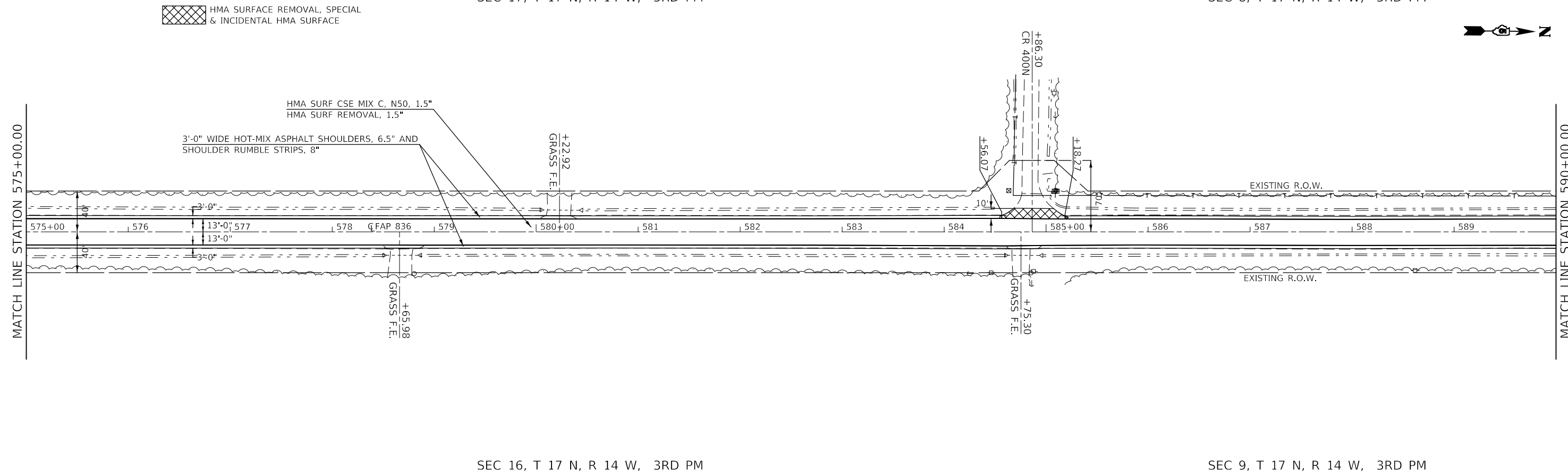

SEC 16, T 17 N, R 14 W, 3RD PM

SEC 9, T 17 N, R 14 W, 3RD PM

SEC 8, T 17 N, R 14 W, 3RD PM

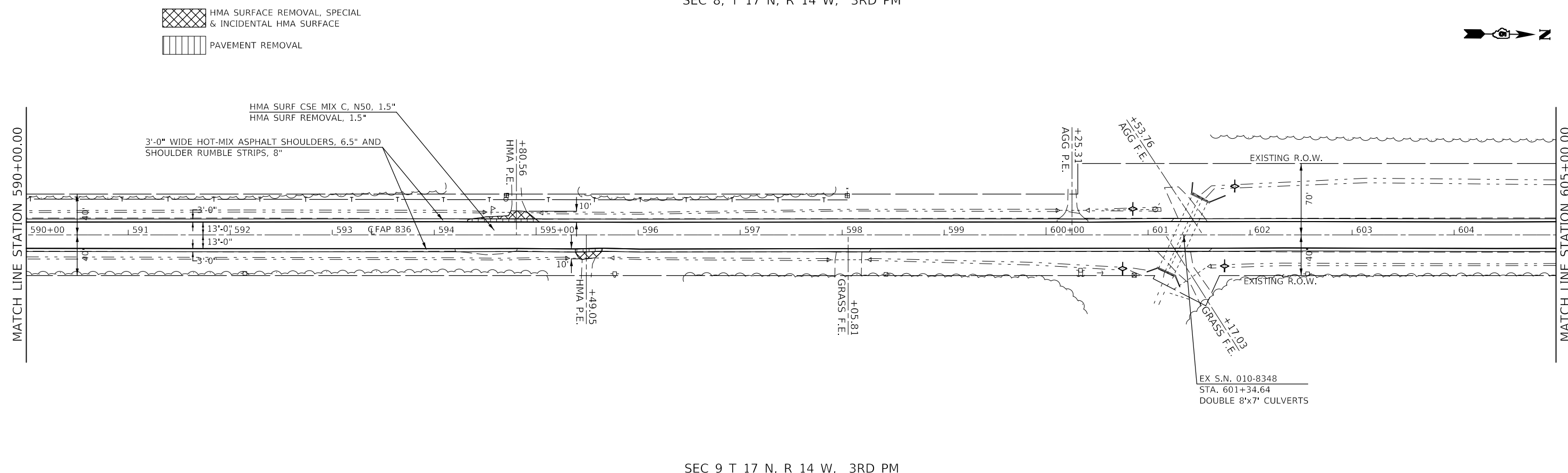

SEC 9 T 17 N, R 14 W, 3RD PM

MODEL: \\MODEL\MH\MS
FILE: \\MS\MS\Proj\118RS-3\119RS-4\Drawings\119RS-4\119RS-4.Dwg
Project: 118RS-3, 119RS-4, D5 HSIP 2019-1
Scale: 1" = 50'

USER NAME = PiersonTJ	DESIGNED -	REVISED -
PLOT SCALE = 100,0000' / in.	DRAWN -	REVISED -
PLOT DATE = 4/3/2019	CHECKED -	REVISED -
	DATE -	REVISED -

STATE OF ILLINOIS
DEPARTMENT OF TRANSPORTATION

IL-49 PLAN SHEETS

SCALE: 1" = 50' SHEET 10 OF 21 SHEETS STA. 575+00.00 TO STA. 605+00.00

F.A.P. RTE.	SECTION	COUNTY	TOTAL SHEETS	SHEET NO.
836	**	-	214	46
CONTRACT NO. 70D56				

SEC 8, T 17 N, R 14 W, 3RD PM

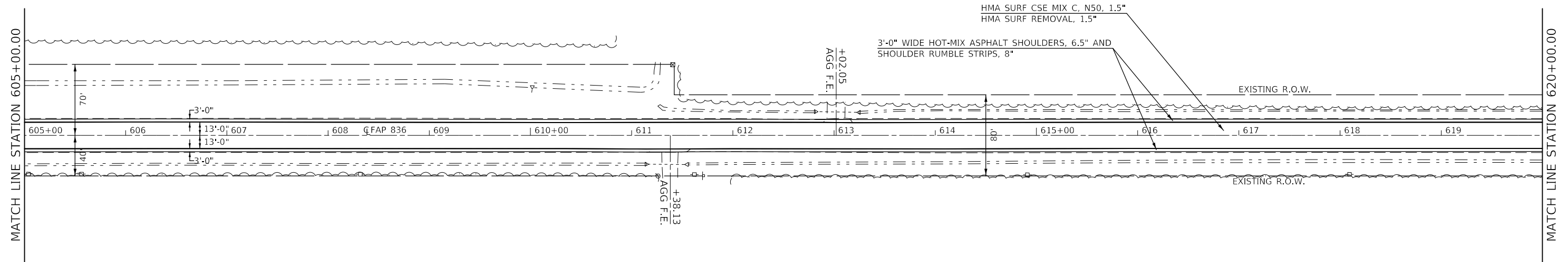

SEC 9 T 17 N, R 14 W, 3RD PM

SEC 8, T 17 N, R 14 W, 3RD PM

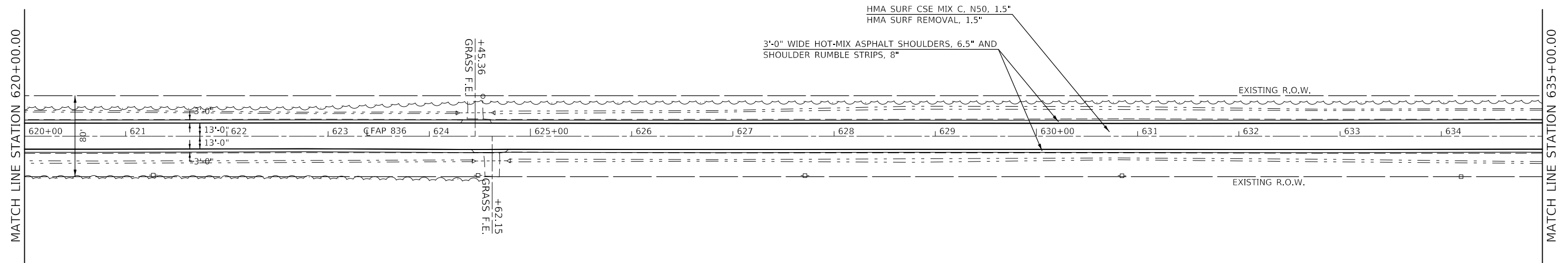

SEC 9 T 17 N, R 14 W, 3RD PM

MODEL: \\MODEL\MARTE
 FILE: \\MARTE_Plan\p118rs-3,119rs-4, D5 HSIP 2019-1\Projects\DOT_0ffice\Drawings\118rs-3,119rs-4, D5 HSIP 2019-1\Plan_Sheet_50_Scale_Sec_1.dgn

USER NAME = PiersonTJ	DESIGNED -	REVISED -
DRAWN -	REVISED -	
PLOT SCALE = 100,0000' / in.	CHECKED -	REVISED -
PLOT DATE = 3/22/2019	DATE -	REVISED -

STATE OF ILLINOIS
DEPARTMENT OF TRANSPORTATION

IL-49 PLAN SHEETS

SCALE: 1" = 50' SHEET 11 OF 21 SHEETS STA. 605+00.00 TO STA. 635+00.00

F.A.P. RTE.	SECTION	COUNTY	TOTAL SHEETS	SHEET NO.
836	**	-	214	47
CONTRACT NO. 70D56				

SEC 5, T 17 N, R 14 W, 3RD PM

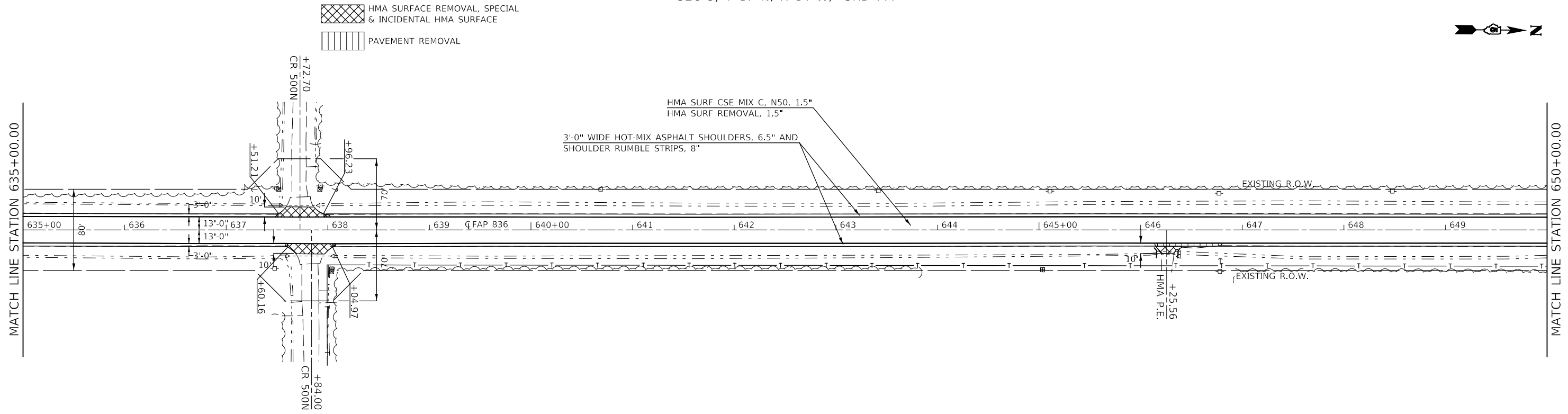

SEC 4 T 17 N, R 14 W, 3RD PM

SEC 5, T 17 N, R 14 W, 3RD PM

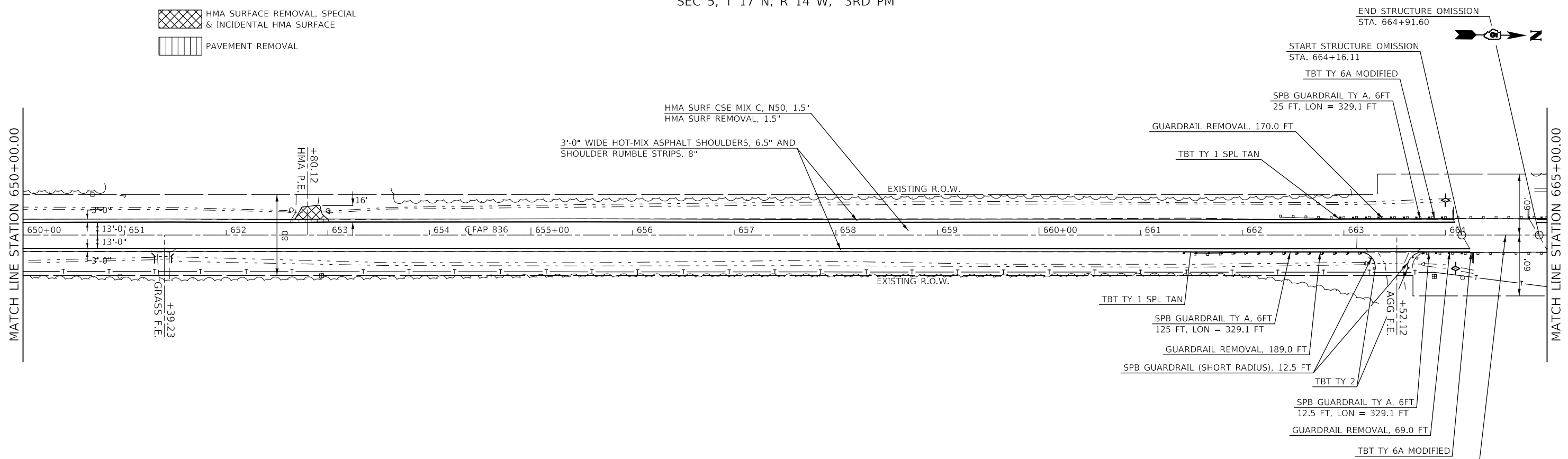

SEC 4 T 17 N, R 14 W, 3RD PM

USER NAME = PiersonTJ	DESIGNED -	REVISED -
DRAWN -	REVISED -	REVISED -
PLOT SCALE = 100.0000' / in.	CHECKED -	REVISED -
PLOT DATE = 4/3/2019	DATE -	REVISED -

STATE OF ILLINOIS
DEPARTMENT OF TRANSPORTATION

IL-49 PLAN SHEETS

SCALE: 1" = 50' SHEET 12 OF 21 SHEETS STA. 635+00.00 TO STA. 665+00.00

F.A.P. RTE.	SECTION	COUNTY	TOTAL SHEETS	SHEET NO.
836	**	-	214	48
CONTRACT NO. 70D56				

MODEL: \\MODEL\MHFS FILE: \\MHFS_Plan\118RS-3\119RS-4\118RS-3-119RS-4-D5-HSIP-2019-1-Plan_Sheet_50_Scale_Sec_1.dgn PROJECT: \\PROJECTS\70D56\CADD\Drawings\70D56-Plan_Sheet_50_Scale_Sec_1.dgn

SEC 5, T 17 N, R 14 W, 3RD PM

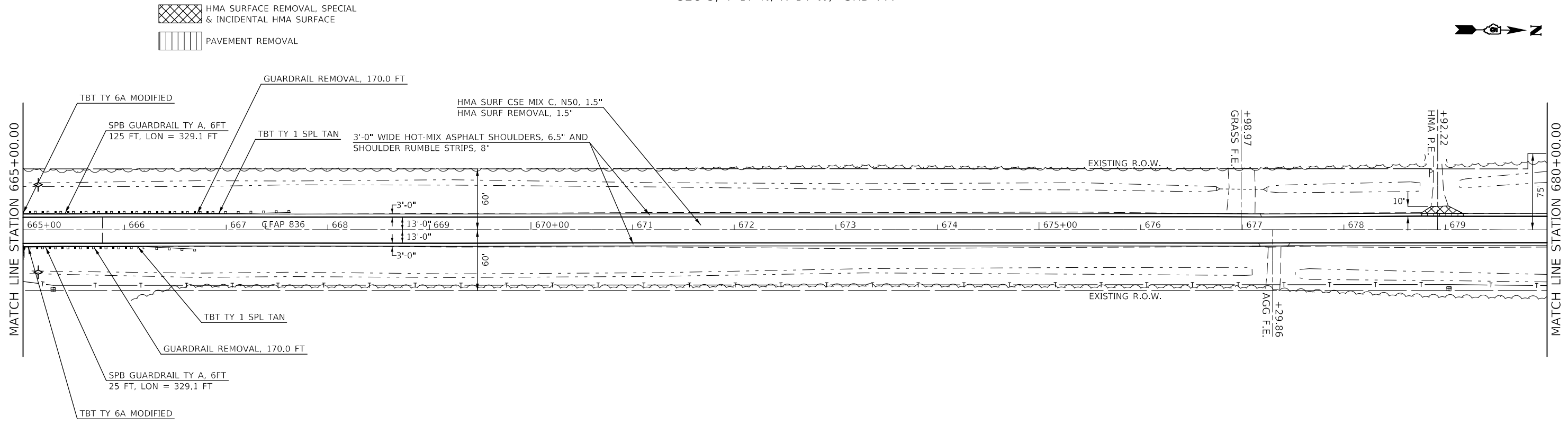

SEC 4 T 17 N, R 14 W, 3RD PM

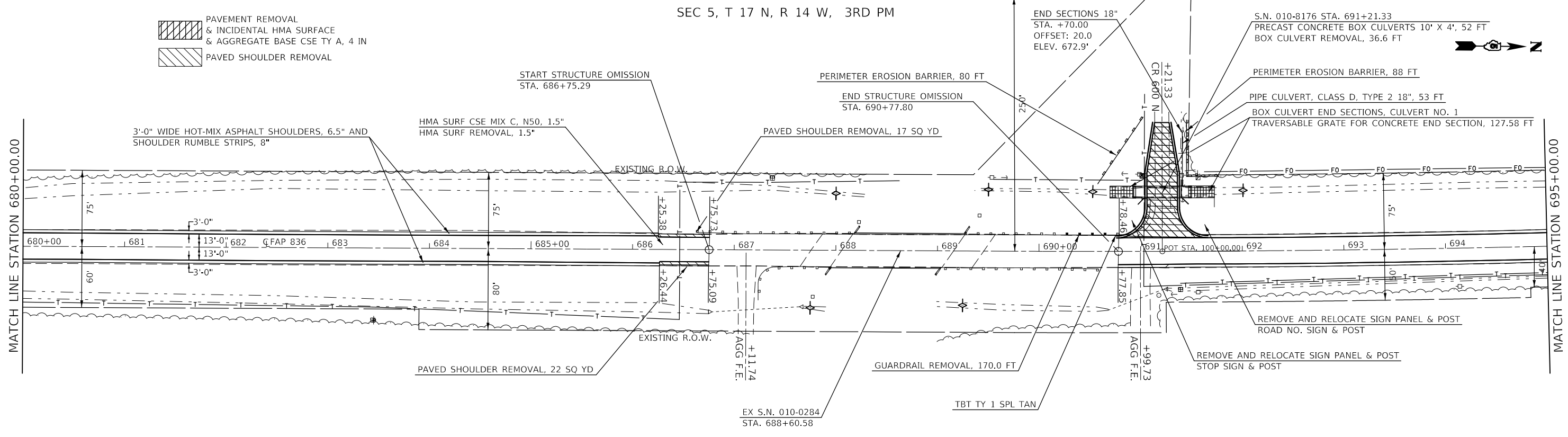

SEC 4 T 17 N, R 14 W, 3RD PM

MODEL: \\MODEL\MHFE
 FILE: \\MAILS_Plan\118RS-3,119RS-4,05 HSIP 2019-1\Documents\DOT_Office\Drawings\Projects\0570D56-HR-Plan_Sheet_50_Scale_Sec 1.dgn

USER NAME = PiersonJ	DESIGNED -	REVISED -
	DRAWN -	REVISED -
PLOT SCALE = 100,0000' / in.	CHECKED -	REVISED -
PLOT DATE = 4/3/2019	DATE -	REVISED -



**STATE OF ILLINOIS
DEPARTMENT OF TRANSPORTATION**

IL-49 PLAN SHEETS

SCALE: 1" = 50' SHEET 13 OF 21 SHEETS STA. 665+00.00 TO STA. 695+00.00

F.A.P. RTE.	SECTION	COUNTY	TOTAL SHEETS	SHEET NO.
836	**	-	214	49
CONTRACT NO. 70D56				

SEC 32, T 17 N, R 14 W, 2ND PM

-  HMA SURFACE REMOVAL, SPECIAL & INCIDENTAL HMA SURFACE
-  PAVEMENT REMOVAL
-  AGGREGATE SURFACE COURSE, TY B

BOX CULVERT END SECTIONS, CULVERT NO. 2
 TRAVERSABLE GRATE FOR CONCRETE END SECTION, 127.58 FT

S.N. 010-8177 STA. 701+63.97
 PRECAST CONCRETE BOX CULVERTS 10' X 4', 26 FT
 BOX CULVERT REMOVAL, 21.7 FT

3'-0" WIDE HOT-MIX ASPHALT SHOULDERS, 6.5" AND
 SHOULDER RUMBLE STRIPS, 8"

HMA SURF CSE MIX C, N50, 1.5"
 HMA SURF REMOVAL, 1.5"

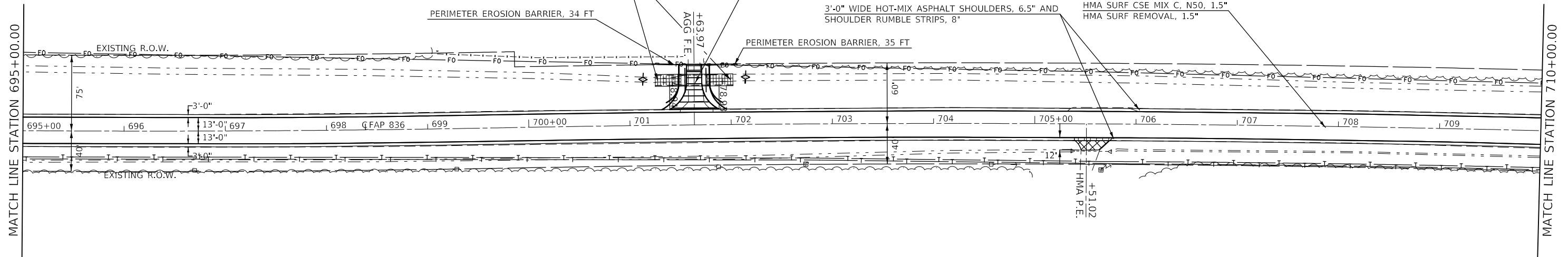

SEC 33 T 17 N, R 14 W, 3RD PM

SEC 32, T 17 N, R 14 W, 2ND PM

3'-0" WIDE HOT-MIX ASPHALT SHOULDERS, 6.5" AND
 SHOULDER RUMBLE STRIPS, 8"

HMA SURF CSE MIX C, N50, 1.5"
 HMA SURF REMOVAL, 1.5"

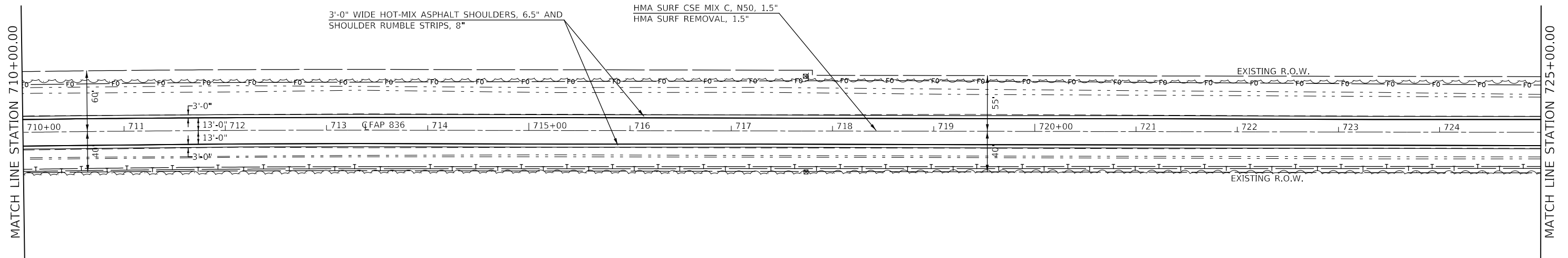

SEC 33 T 17 N, R 14 W, 3RD PM

MODEL: \\MODEL\MHFS
 FILE: \\MAILS: \pub\hmm\com\ad\illinois\gov\PIWDOT\Documents\DOT_Offices\District 5\Projects\05700556\05700556-Plan_Sheet_50_Scale_Set_1.dgn

USER NAME = PiersonTJ	DESIGNED -	REVISED -
	DRAWN -	REVISED -
PLOT SCALE = 100.0000' / in.	CHECKED -	REVISED -
PLOT DATE = 4/3/2019	DATE -	REVISED -

**STATE OF ILLINOIS
 DEPARTMENT OF TRANSPORTATION**

IL-49 PLAN SHEETS

SCALE: 1" = 50' SHEET 14 OF 21 SHEETS STA. 695+00.00 TO STA. 725+00.00

F.A.P. RTE.	SECTION	COUNTY	TOTAL SHEETS	SHEET NO.
836	**	-	214	50
CONTRACT NO. 70D56				

SEC 32, T 17 N, R 14 W, 2ND PM

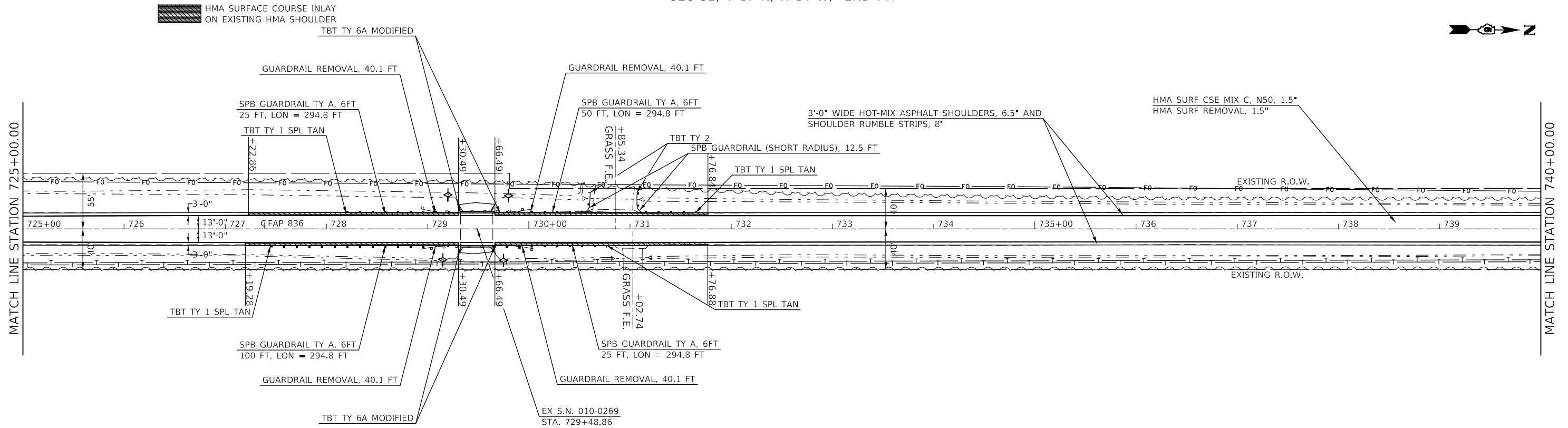

SEC 33 T 17 N, R 14 W, 3RD PM

SEC 29, T 17 N, R 14 W, 2ND PM

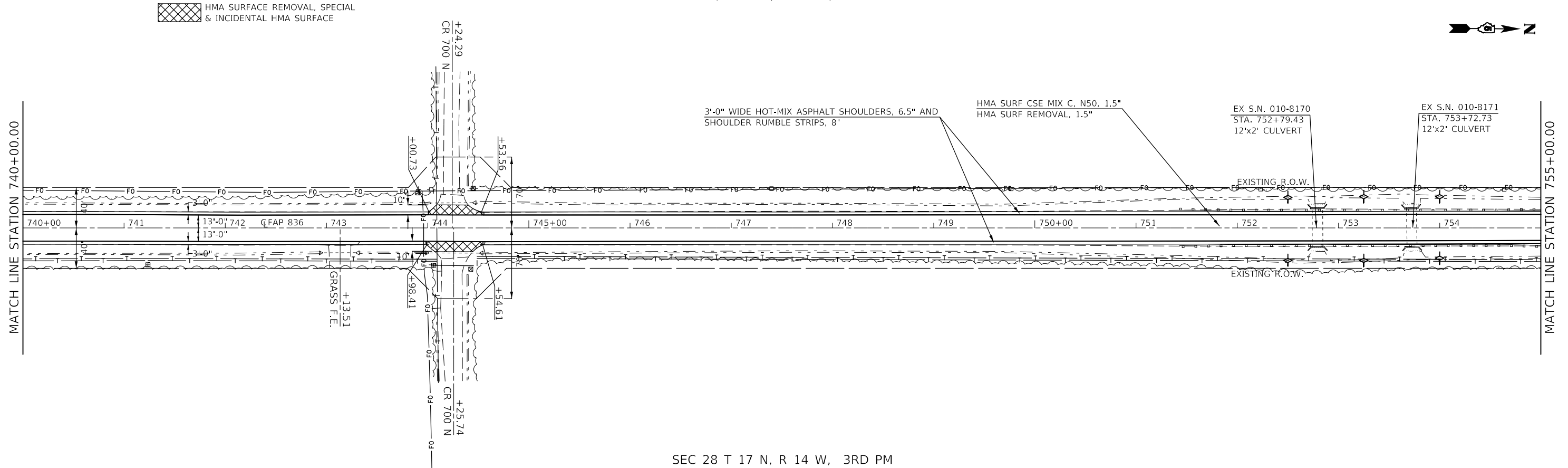

SEC 28 T 17 N, R 14 W, 3RD PM

MODEL: I:\MODEL\MHMS
 FILE: MHMS_Plan.dwg
 PROJECT: I:\Projects\057005\056\056\056.dwg
 SHEET: 50
 SCALE: 1:50
 DATE: 4/3/2019

USER NAME = PiersonTJ	DESIGNED -	REVISED -
PLOT SCALE = 100,0000' / in.	DRAWN -	REVISED -
PLOT DATE = 4/3/2019	CHECKED -	REVISED -
	DATE -	REVISED -



STATE OF ILLINOIS
DEPARTMENT OF TRANSPORTATION

IL-49 PLAN SHEETS

SCALE: 1" = 50' SHEET 15 OF 21 SHEETS STA. 725+00.00 TO STA. 755+00.00

F.A.P. RTE.	SECTION	COUNTY	TOTAL SHEETS	SHEET NO.
836	**	-	214	51
CONTRACT NO. 70D56				

SEC 29, T 17 N, R 14 W, 2ND PM

 HMA SURFACE REMOVAL, SPECIAL & INCIDENTAL HMA SURFACE
 PAVEMENT REMOVAL

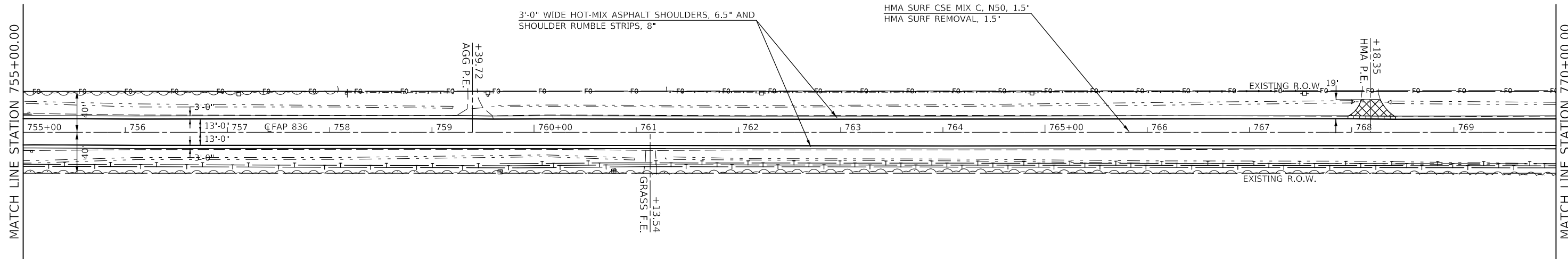

SEC 28 T 17 N, R 14 W, 3RD PM

SEC 29, T 17 N, R 14 W, 2ND PM

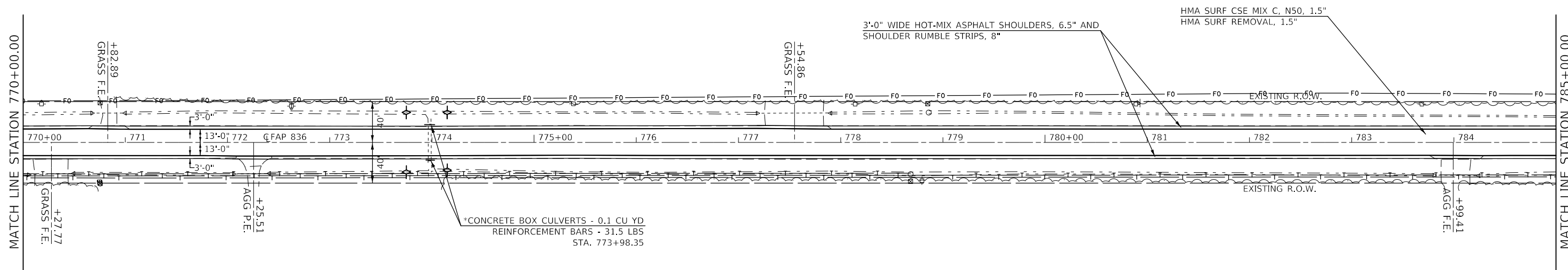

SEC 28 T 17 N, R 14 W, 3RD PM

* REMOVAL AND REERECTION OF DELINATOR AT CULVERT INCLUDED IN HEADWALL EXTENSION PAY ITEMS

MODEL: \\MODEL\MHFE
 FILE: \\MAILS_Plan\p118rs-3-119rs-4-d5 HSIP 2019-1\Documents\DOT_Offices\District 5\Projects\0570D56\0570D56-Plan_Sheet_50_Scale_Sec 1.dgn

USER NAME = PiersonTJ	DESIGNED -	REVISED -
PLOT SCALE = 100,0000' / in.	DRAWN -	REVISED -
PLOT DATE = 4/3/2019	CHECKED -	REVISED -
	DATE -	REVISED -

**STATE OF ILLINOIS
DEPARTMENT OF TRANSPORTATION**

IL-49 PLAN SHEETS

SCALE: 1" = 50' SHEET 16 OF 21 SHEETS STA. 755+00.00 TO STA. 785+00.00

F.A.P. RTE.	SECTION	COUNTY	TOTAL SHEETS	SHEET NO.
836	**	-	214	52
CONTRACT NO. 70D56				

SEC 29, T 17 N, R 14 W, 2ND PM

 HMA SURFACE REMOVAL, SPECIAL & INCIDENTAL HMA SURFACE

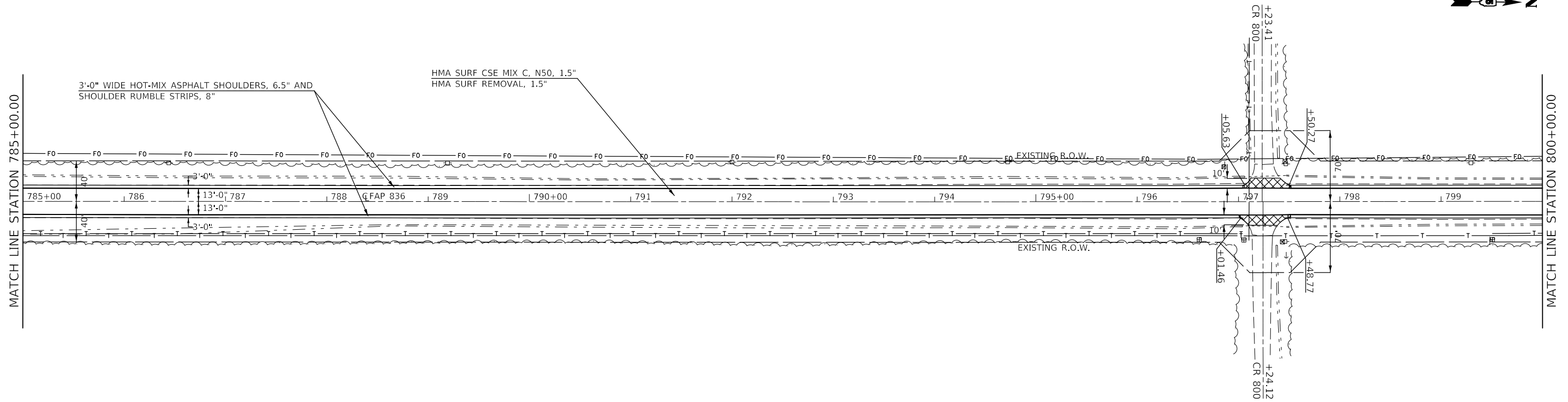
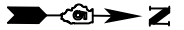

SEC 28 T 17 N, R 14 W, 3RD PM

SEC 20, T 17 N, R 14 W, 2ND PM

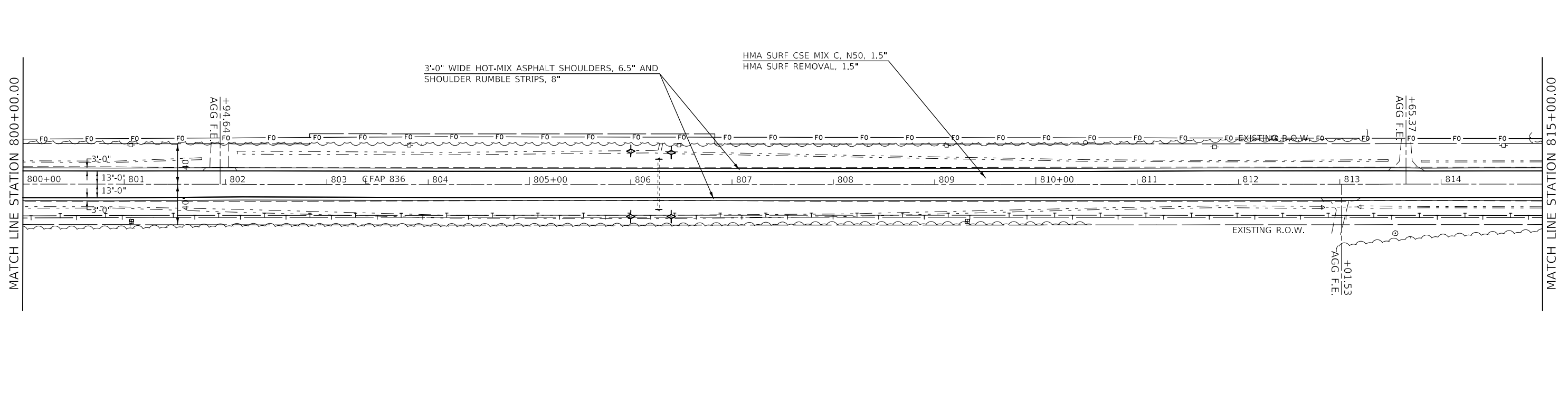

SEC 21 T 17 N, R 14 W, 3RD PM

MODEL: \\MODEL\MARIS
 FILE: \\MARIS_Plan\118RS-3\118RS-4\05_HSP19-1\Documents\DOT_Offices\Drawings\Projects\0570D56\Drawings\Plan_Sheet_50_Scale_Set_1.dgn

USER NAME = PiersonTJ	DESIGNED -	REVISED -
PLOT SCALE = 100,0000' / in.	DRAWN -	REVISED -
PLOT DATE = 4/3/2019	CHECKED -	REVISED -
	DATE -	REVISED -

**STATE OF ILLINOIS
DEPARTMENT OF TRANSPORTATION**

IL-49 PLAN SHEETS

SCALE: 1" = 50' SHEET 17 OF 21 SHEETS STA. 785+00.00 TO STA. 815+00.00

F.A.P. RTE.	SECTION	COUNTY	TOTAL SHEETS	SHEET NO.
836	**	-	214	53
CONTRACT NO. 70D56				

SEC 20, T 17 N, R 14 W, 2ND PM

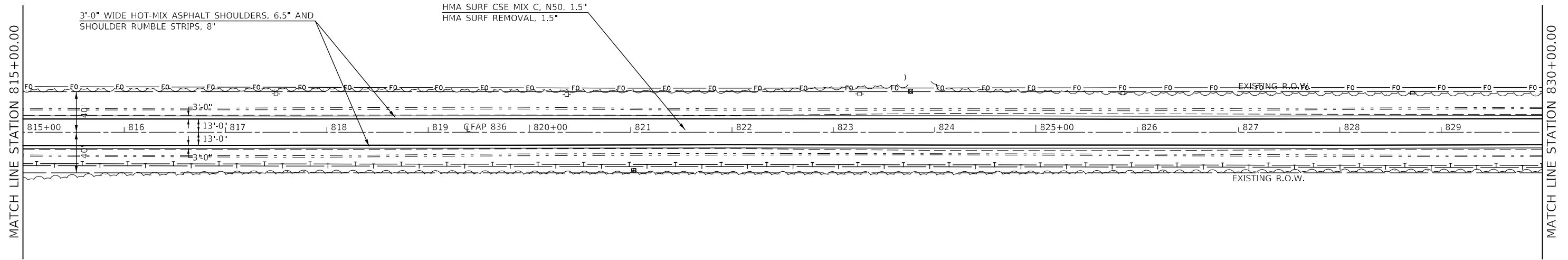

SEC 21 T 17 N, R 14 W, 3RD PM

SEC 20, T 17 N, R 14 W, 2ND PM

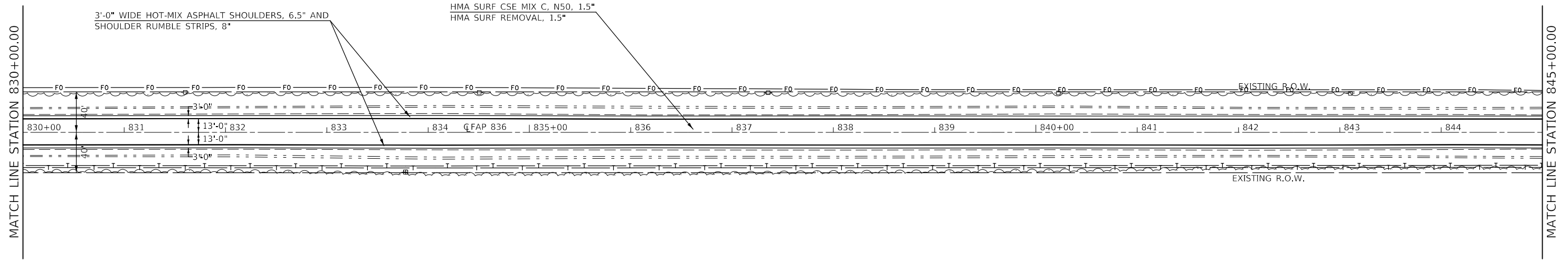

SEC 21 T 17 N, R 14 W, 3RD PM

MODEL: \\MODEL\MARIS
 FILE: \\MARIS_Plan\Highway\70D56\Drawings\DOT_Offices\Drawings\70D56\Ht-Plan_Sheet_50_Scale_Sec 1.dgn

USER NAME = PiersonTJ	DESIGNED -	REVISED -
PLOT SCALE = 100,0000' / in.	DRAWN -	REVISED -
PLOT DATE = 3/22/2019	CHECKED -	REVISED -
	DATE -	REVISED -



**STATE OF ILLINOIS
DEPARTMENT OF TRANSPORTATION**

IL-49 PLAN SHEETS

SCALE: 1" = 50' SHEET 18 OF 21 SHEETS STA. 815+00.00 TO STA. 845+00.00

F.A.P. RTE.	SECTION	COUNTY	TOTAL SHEETS	SHEET NO.
836	**	-	214	54
CONTRACT NO. 70D56				

SEC 17, T 18 N, R 14 W, 2ND PM

 HMA SURFACE REMOVAL, SPECIAL & INCIDENTAL HMA SURFACE
 PAVEMENT REMOVAL

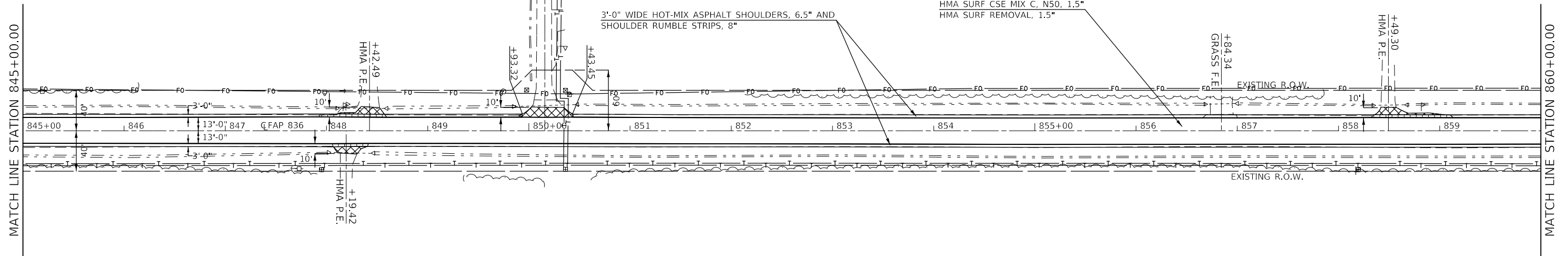

SEC 16 T 18 N, R 14 W, 3RD PM

SEC 17, T 18 N, R 14 W, 2ND PM

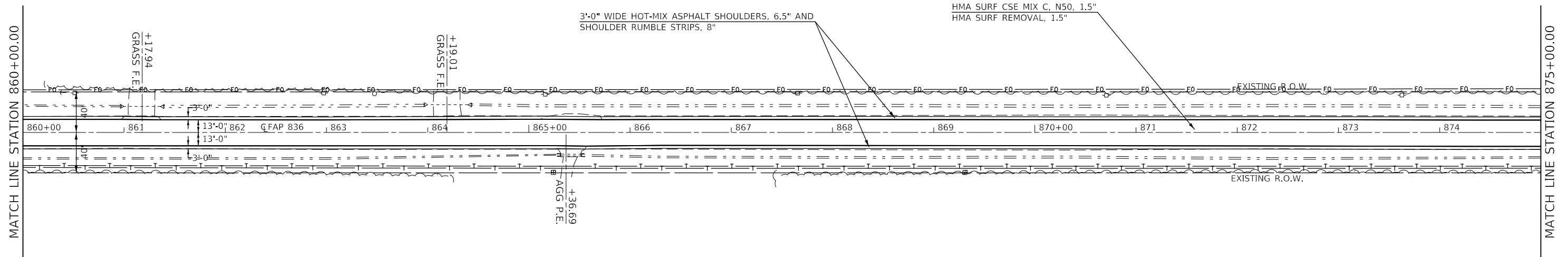

SEC 16 T 18 N, R 14 W, 3RD PM

MODEL: s:\MODEL\MHFS
 FILE: mhfs_3119RS-3,119RS-4.D5 CHAMPAIN\Drawings\DOT_Offices\Drawings\70D56-HR-Plan_Sheet_50_Scale_Sec 1.dgn

USER NAME = PiersonTJ	DESIGNED -	REVISED -
	DRAWN -	REVISED -
PLOT SCALE = 100.0000' / in.	CHECKED -	REVISED -
PLOT DATE = 4/3/2019	DATE -	REVISED -

**STATE OF ILLINOIS
DEPARTMENT OF TRANSPORTATION**

IL-49 PLAN SHEETS

SCALE: 1" = 50' SHEET 19 OF 21 SHEETS STA. 845+00.00 TO STA. 875+00.00

F.A.P. RTE.	SECTION	COUNTY	TOTAL SHEETS	SHEET NO.
836	**	-	214	55
CONTRACT NO. 70D56				

SEC 17, T 18 N, R 14 W, 2ND PM

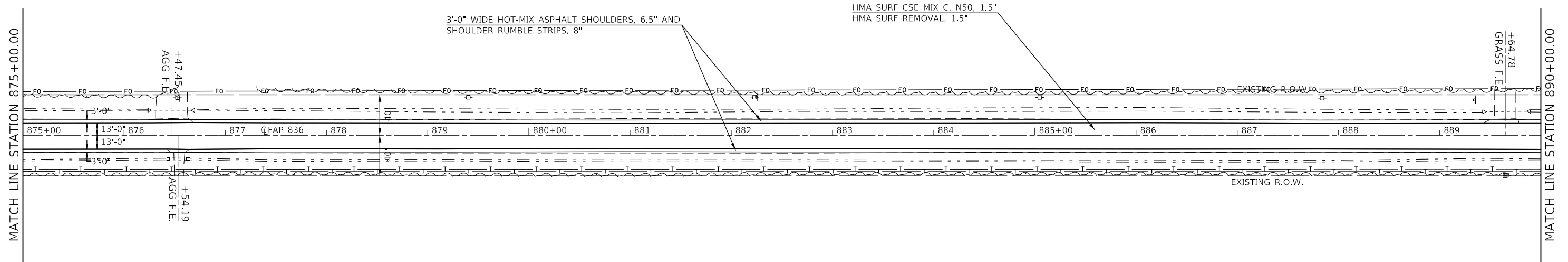

SEC 16 T 18 N, R 14 W, 3RD PM

SEC 17, T 18 N, R 14 W, 2ND PM



- HMA SURFACE REMOVAL, SPECIAL & INCIDENTAL HMA SURFACE
- PAVEMENT REMOVAL
- HMA SURFACE COURSE INLAY ON EXISTING HMA SHOULDER

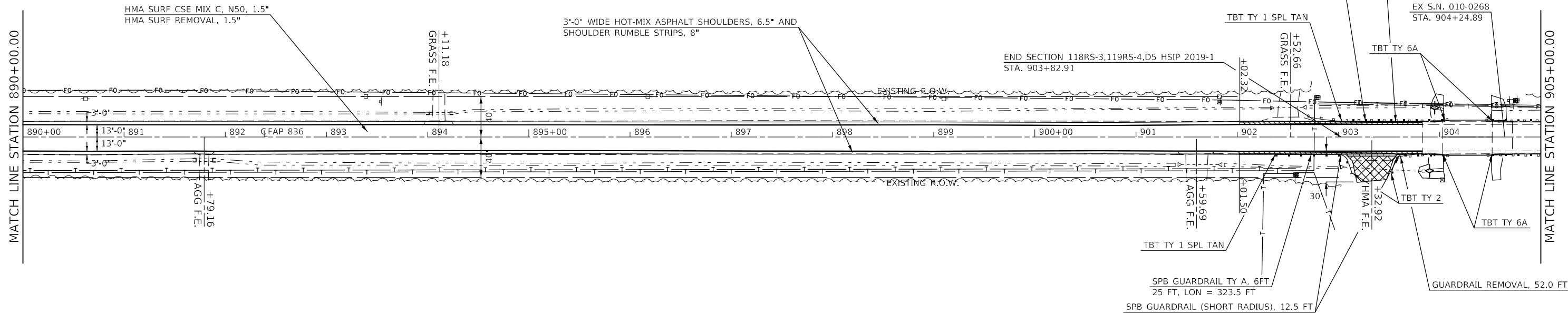

SEC 16 T 18 N, R 14 W, 3RD PM

MODEL: I:\MODEL\MAR15
 FILE: MAR15_Plan\118RS-3,119RS-4,D5 HSIP 2019-1.dgn
 PROJECT: I:\PROJECTS\118RS-3,119RS-4,D5 HSIP 2019-1\118RS-3,119RS-4,D5 HSIP 2019-1.dgn
 SHEET: 50 Scale: 1:50

USER NAME = PiersonJ	DESIGNED -	REVISED -
	DRAWN -	REVISED -
PLOT SCALE = 100.0000' / in.	CHECKED -	REVISED -
PLOT DATE = 4/3/2019	DATE -	REVISED -

**STATE OF ILLINOIS
DEPARTMENT OF TRANSPORTATION**

IL-49 PLAN SHEETS

SCALE: 1" = 50' SHEET 20 OF 21 SHEETS STA. 875+00.00 TO STA. 905+00.00

F.A.P. RTE.	SECTION	COUNTY	TOTAL SHEETS	SHEET NO.
836	**	-	214	56
CONTRACT NO. 70D56				



END SECTIONS 18"
 STA. +70.00
 OFFSET: 20.0
 ELEV. 672.9'

PIPE CULVERTS, CLASS D, TYPE 2 18", 53 FT

S.N. 010-8176 STA. 691+21.33
 PRECAST CONCRETE BOX CULVERTS 10' X 4', 52 FT
 BOX CULVERT REMOVAL, 36.6 FT

BOX CULVERT END SECTIONS, CULVERT NO. 1
 TRAVERSABLE GRATE FOR CONCRETE END SECTION, 127.58 FT

HMA SURFACE COURSE MIX C, N50 1.5 IN
 AGG. BASE COURSE, TY. A, 4 IN

PAVEMENT REMOVAL

AGGREGATE SHOULDERS
 TYPE B

BOX CULVERT END SECTIONS, CULVERT NO. 1
 TRAVERSABLE GRATE FOR CONCRETE END SECTION, 127.58 FT

GUARDRAIL REMOVAL, 170.0 FT

TBT TY 1 SPL TAN

STA 691+21.33 FAP 836 (IL-49)
 STA. 100+00.00 CR 600N

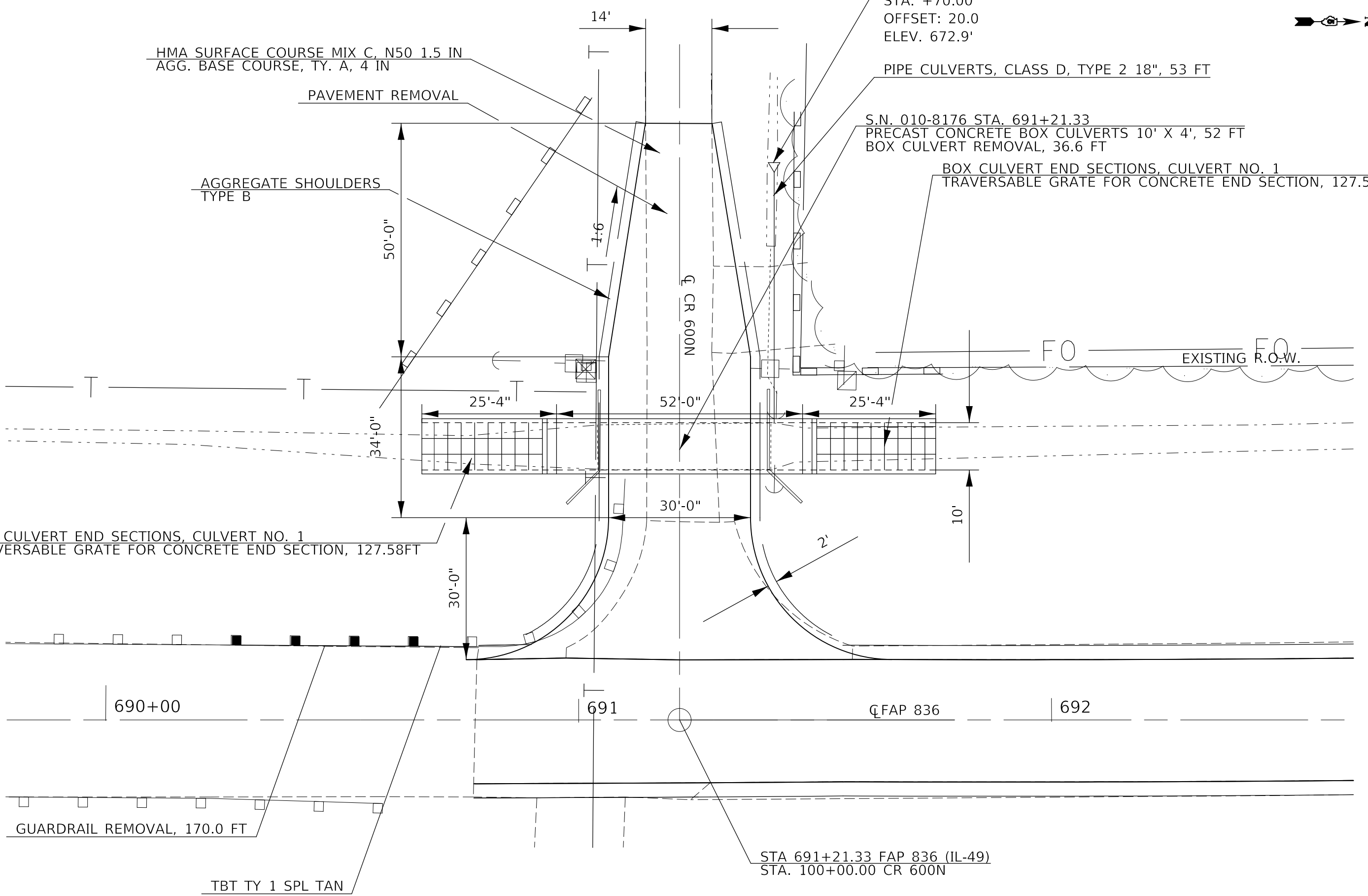

MODEL: \\MODEL\NAMES
 FILE: \\models\pav\champaign\road\illinois\gov\pww\dot\Documents\DOT_Offices\Illin\dot\Projects\0570D56\CADD\Drawn\Design\0570D56-ht-Culvert_Plan_Sheet.dgn

USER NAME = PiersonTJ	DESIGNED -	REVISED -
	DRAWN -	REVISED -
PLOT SCALE = 20.0000 ' / in.	CHECKED -	REVISED -
PLOT DATE = 3/22/2019	DATE -	REVISED -

**STATE OF ILLINOIS
 DEPARTMENT OF TRANSPORTATION**

**CR 600N - S.N. 010-8176
 DETAILED PLAN SHEET**

SCALE: 1" = 10' SHEET 1 OF 2 SHEETS STA. TO STA.

F.A.P. RTE.	SECTION	COUNTY	TOTAL SHEETS	SHEET NO.
836	**	-	214	58
			CONTRACT NO. 70D56	



S.N. 010-8177 STA. 701+63.97
 PRECAST CONCRETE BOX CULVERTS 10' X 4', 52 FT
 BOX CULVERT REMOVAL, 21.7 FT

AGG. SURFACE COURSE, TY. B

FIELD ENTRANCE

BOX CULVERT END SECTIONS, CULVERT NO. 2
 TRAVERSABLE GRATE FOR CONCRETE END SECTION, 127.58 FT

BOX CULVERT END SECTIONS, CULVERT NO. 2
 TRAVERSABLE GRATE FOR CONCRETE END SECTION, 127.58 FT

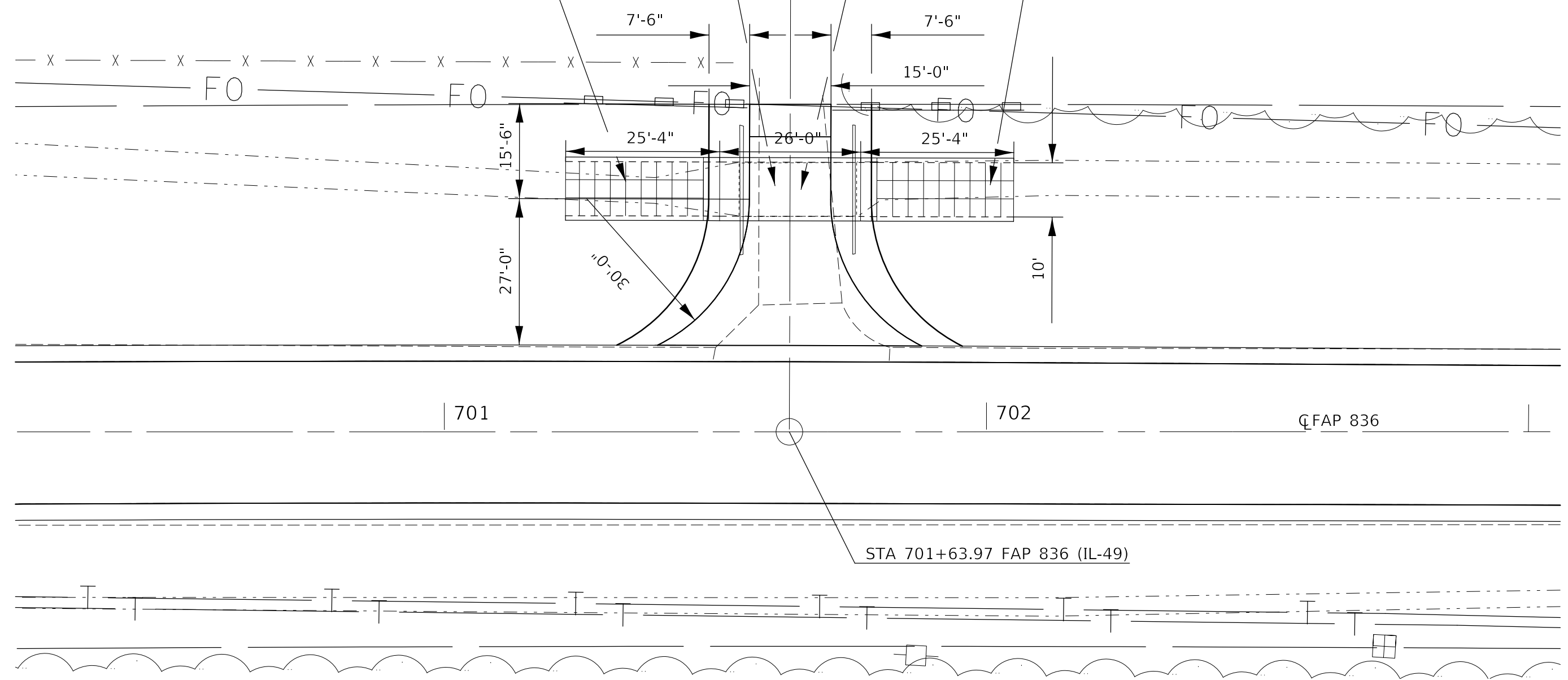

STA 701+63.97 FAP 836 (IL-49)

MODEL: \\MODEL\MAT\...
 FILE: \\MAT\...
 PROJECT: \\PROJECT\...
 OFFICE: \\OFFICE\...
 DRAWING: \\DRAWING\...

USER NAME = PiersonTJ	DESIGNED -	REVISED -
	DRAWN -	REVISED -
PLOT SCALE = 20.0000 ' / in.	CHECKED -	REVISED -
PLOT DATE = 3/22/2019	DATE -	REVISED -

STATE OF ILLINOIS
 DEPARTMENT OF TRANSPORTATION

FIELD ENTRANCE - S.N. 010-8177
 DETAILED PLAN SHEET

SCALE: 1" = 10' SHEET 2 OF 2 SHEETS STA. TO STA.



F.A.P. RTE.	SECTION	COUNTY	TOTAL SHEETS	SHEET NO.
836	**	-	214	59
			CONTRACT NO. 70D56	

STRUCTURE 010-0269 WAS ORIGINALLY BUILT IN 1992 AS SECTION 119B-2 AT STATION 729+74.00 BY THE STATE OF ILLINOIS.

THE EXISTING STRUCTURE IS A SINGLE SPAN, 13 1/2" THICK, REINFORCED CONCRETE SLAB BRIDGE ON PILE SUPPORTED ABUTMENTS WITH A BACK-TO-BACK OF ABUTMENT LENGTH OF 33'-0", OUT-TO-OUT WIDTH OF 35'-0", BRIDGE ROADWAY WIDTH OF 31'-9 1/2" AND AN APPROACH ROADWAY WIDTH OF 32'-0". IN 2007 A 2" THICK WATERPROOFING MEMBRANE SYSTEM WAS PLACED ON THE DECK.

METHOD OF CONSTRUCTION: STAGED CONSTRUCTION

LEGEND

-  HMA Surface Removal - 1/2"
-  HMA Surface Removal (Deck)
-  Waterproofing Membrane System

Exst. S.N. 010-0269
 IL 49 @ Sta. 729+74.00 (Old Alignment)
 IL 49 @ Sta. 729+48.54 (Current Alignment)

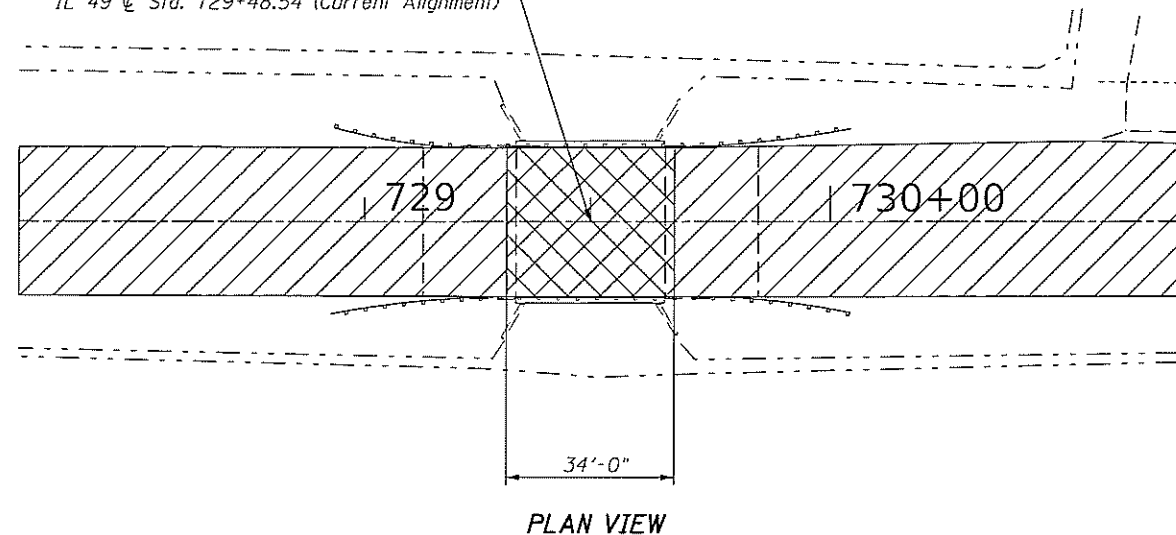

PLAN VIEW

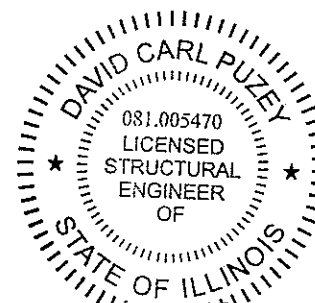

David Carl Puzey 5/2/19
Expire 11/30/20

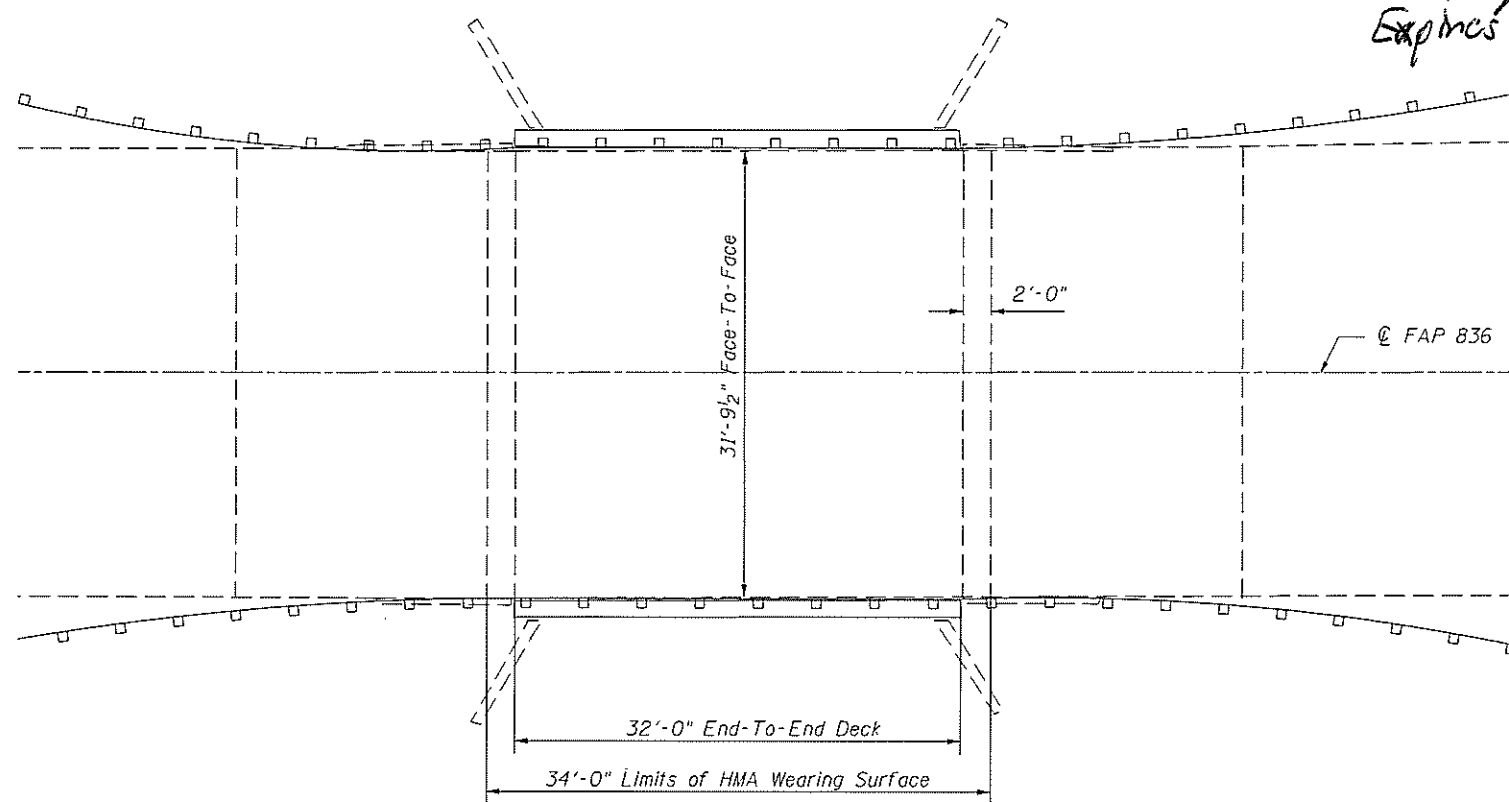

PLAN VIEW

EXISTING DECK CROSS SECTION (LOOKING NORTH)

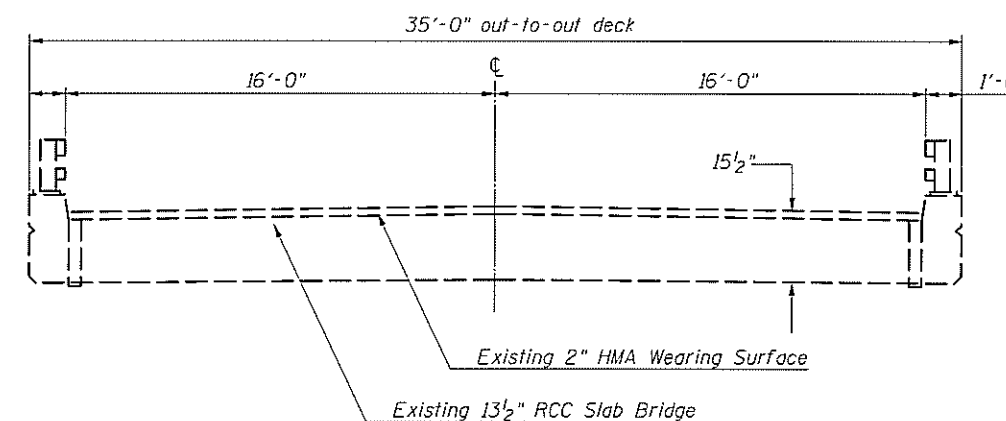

PROPOSED DECK CROSS SECTION (LOOKING NORTH)

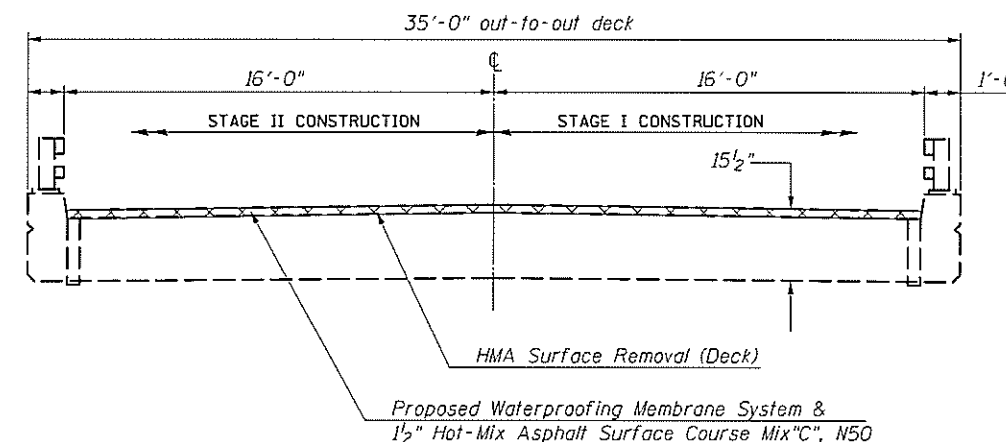

GENERAL NOTES

Plan dimensions and details relative to existing plans are subject to nominal construction variations. The Contractor shall field verify existing dimensions and details affecting new construction and make necessary approved adjustments prior to construction or ordering of materials. Such variations shall not be cause for additional compensation for a change in scope of work. However, the Contractor will be paid for the quantity actually furnished at the unit price for the work.

Deck Slab Repair of 7% of total deck area was estimated. The Engineer shall show actual locations of Deck Repair on As-Built Plans. The preferred method of recording this information is data recording by GPS or Total Station, processed in Microstation. If desired, the Engineer may record by hand.

Paver Electronic Grade Controls shall be operated from preset grade control shall be operated from preset grade control stringline. See article 406.06(e).

PROPOSED WORK

1. Remove existing HMA wearing surface and waterproofing membrane system.
2. Perform Deck Slab Repair (Partial Depth)
3. Place new waterproofing membrane system.
4. Place 1 1/2" of HMA Surface Course over deck.

* Bill of Materials includes quantities associated with S.N. 010-0269 only. See Roadway Plans for other quantities.

*** TOTAL BILL OF MATERIAL S.N. 010-0269**

ITEM	UNIT	TOTAL
Bituminous Materials (Tack Coat)	Pound	54.0
HMA Surface Course, Mix "C", N50	Ton	11.0
HMA Surface Removal (Deck)	Sq Yd.	121.0
Waterproofing Membrane System	Sq Yd.	121.0
Deck Slab Repair (Partial Depth)	Sq Yd.	9.0

USER NAME = PiersonTJ	DESIGNED - TJP	REVISED -
PLOT SCALE = 40,0000' / in.	DRAWN - RTC	REVISED -
PLOT DATE = 3/22/2019	CHECKED -	REVISED -
	DATE -	REVISED -

STATE OF ILLINOIS
 DEPARTMENT OF TRANSPORTATION

GENERAL PLAN & STRUCTURE DETAIL
 S.N. 010-0269

SCALE: NONE SHEET 1 OF 3 SHEETS STA. TO STA.

F.A.P. RTE.	SECTION	COUNTY	TOTAL SHEETS	SHEET NO.
836	**		214	60
CONTRACT NO. 70D56			ILLINOIS FED. AID PROJECT	

STAGE I CONSTRUCTION DETAIL

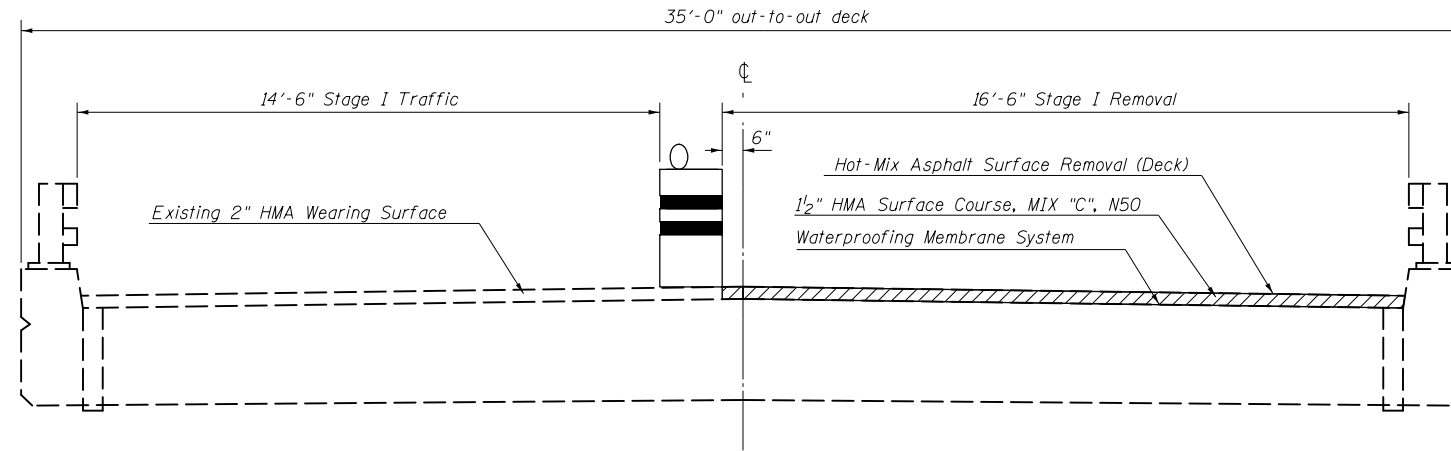

STAGE II CONSTRUCTION DETAIL

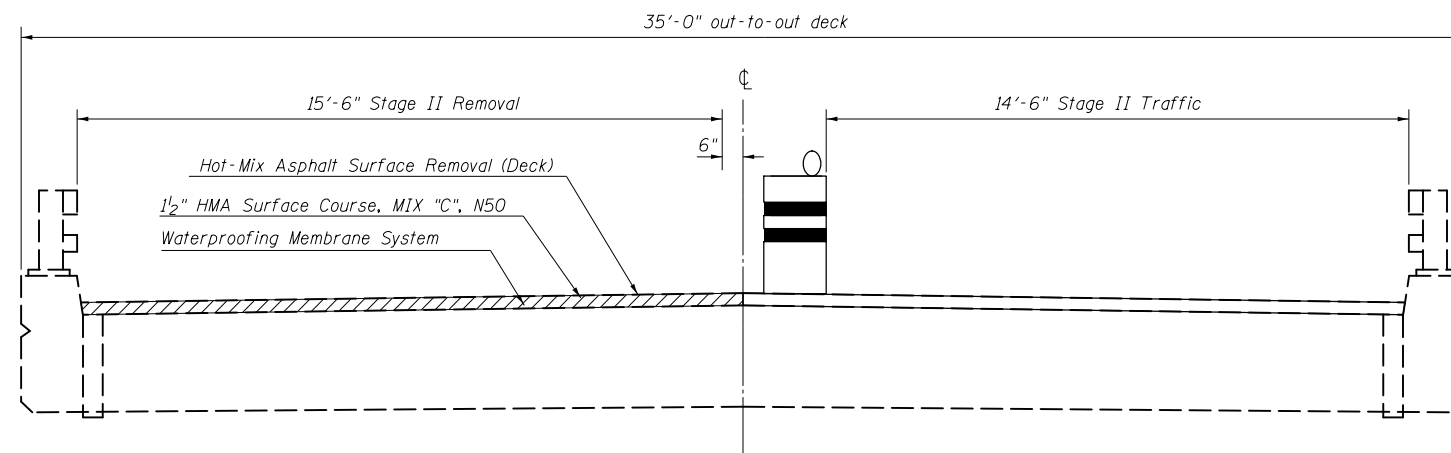

MODEL: \\MODEL\MAME
 FILE: \\name: p:\pub\mcom\m.d\illinois.gov\PWIDOT\Documents\DOT_Offices\Director_S\Projects\0570D56\CADD\Drawings\0570D56-ht-St_010-0269.dgn

USER NAME = PiersonJ	DESIGNED -	REVISED -
	DRAWN -	REVISED -
PLOT SCALE = 40,0000 ' / in.	CHECKED -	REVISED -
PLOT DATE = 4/29/2019	DATE -	REVISED -

STATE OF ILLINOIS
DEPARTMENT OF TRANSPORTATION

TYPICAL STAGING CONSTRUCTION DETAIL
S.N. 010-0269

SCALE: NONE SHEET 2 OF 3 SHEETS STA. TO STA.

F.A.P. RTE.	SECTION	COUNTY	TOTAL SHEETS	SHEET NO.
836	**	-	214	61
			CONTRACT NO. 70D56	

NOTES

THIS DETAIL HAS BEEN INCLUDED TO ILLUSTRATE THE ASSOCIATED LAYERS AND CURE TIMES NECESSARY FOR THE PLACEMENT OF THE WATERPROOFING MEMBRANE SYSTEM. THIS DETAIL SHALL SUPPLEMENT, NOT SUPERSEDE, SECTION 581 OF THE STANDARD SPECIFICATIONS.

PRIOR TO PLACEMENT OF HMA SURFACE COURSE ON APPROACHES AND DECK THE ENGINEER SHALL SET A RELATIVE STRINGLINE TO ESTABLISH A SMOOTH PROFILE GRADE. THE STRINGLINE SHALL BE ERECTED, MAINTAINED, REMOVED AND DISPOSED OF BY THE CONTRACTOR. THE COST SHALL BE INCLUDED IN THE VARIOUS PAY ITEMS ASSOCIATED WITH PLACING THE NEW WEARING SURFACE.

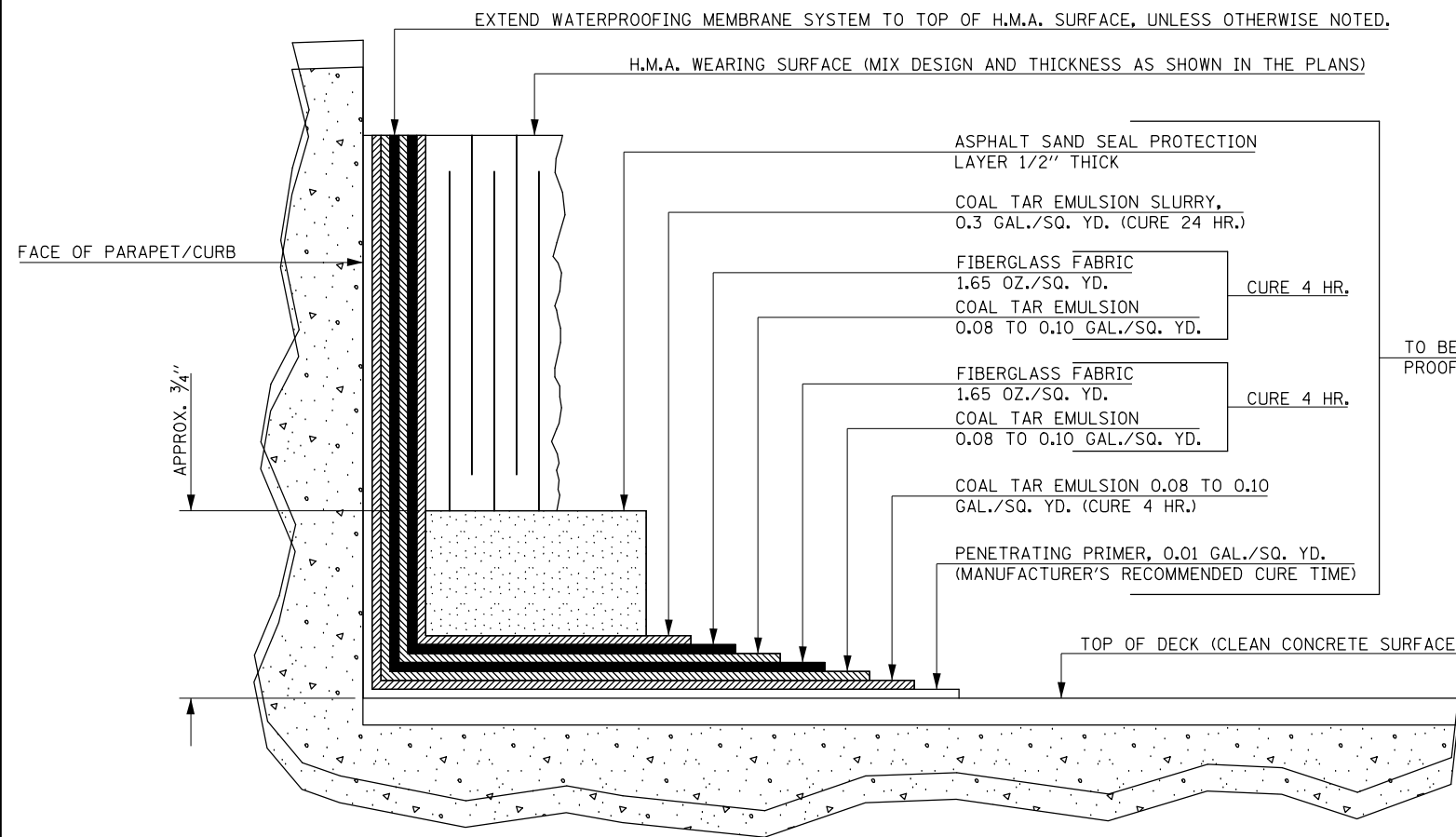

TO BE PAID FOR AS WATER-PROOFING MEMBRANE SYSTEM

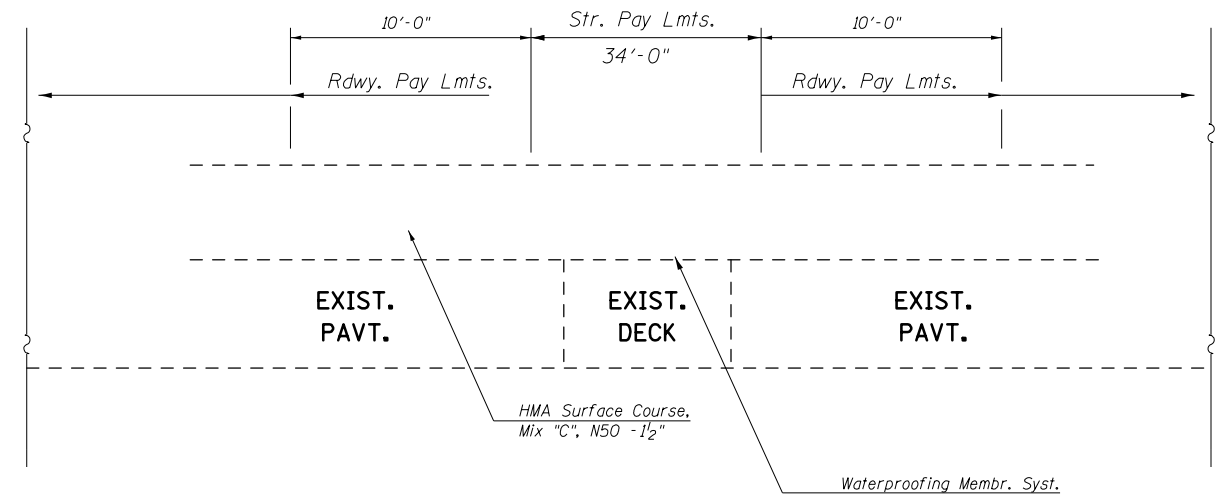

PROPOSED PAVEMENT TRANSITION

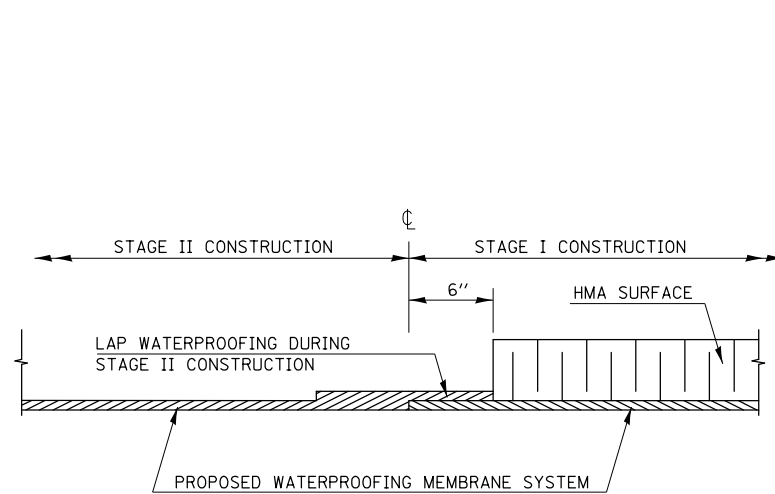

WATERPROOFING TREATMENT AT STAGE CONSTRUCTION

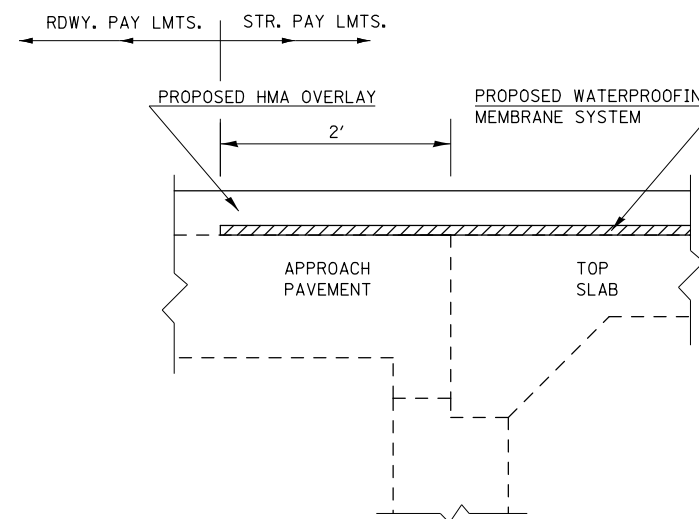

SECTION AT ABUTMENT (VIEW OF WATERPROOFING MEMBRANE AT JOINT)

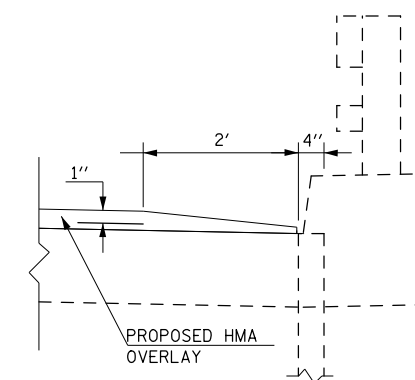

SECTION AT DRAIN

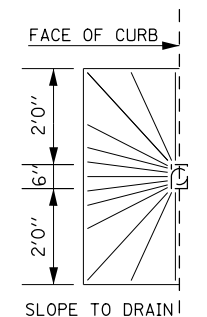

PLAN VIEW AT DRAIN

MODEL: I:\MODEL\MHMF... FILE: MHMF... PROJECT: 010-0269.dgn

USER NAME = PiersonTJ	DESIGNED -	REVISED -
PLOT SCALE = 40.0000 ' / in.	DRAWN -	REVISOR -
PLOT DATE = 3/22/2019	CHECKED -	REVISOR -
	DATE -	REVISOR -

**STATE OF ILLINOIS
DEPARTMENT OF TRANSPORTATION**

WATERPROOFING MEMBRANE DETAIL			
S.N. 010-0269			
SCALE:	SHEET 3	OF 3 SHEETS	STA. TO STA.

F.A.P. RTE.	SECTION	COUNTY	TOTAL SHEETS	SHEET NO.
836	**	-	214	62
CONTRACT NO. 70D56				

ROUTE NO.	SECTION	COUNTY	TOTAL SHEETS	SHEET NO.
F.A.P. 836	1198-2	CHAMPAIGN	39	16
FED. ROAD DIST NO. 7 ILLINOIS FED. AID PROJECT				

SHEET NO. 1
OF 8 SHEETS

BENCHMARK: PK NAIL IN EAST FACE OF FENCE
POST, 41' LEFT, STATION 730+01, ELEVATION 675.48

EXISTING STRUCTURE: S.N. 010-8338: THIS STRUCTURE WAS BUILT IN 1928 AS S.B.I. ROUTE 49, SECTION 119. IT IS A DOUBLE BOX CULVERT 5'-2" BOXES WITH AN OUT-TO-OUT WIDTH OF 35'-4" AND A BACK-TO-BACK LENGTH OF 12'-0". THE EXISTING STRUCTURE SHALL BE REPLACED IN ITS ENTIRETY WITH A SINGLE SPAN REINFORCED CONCRETE ROAD BRIDGE ON ABUTMENTS.

ONE LANE OF TRAFFIC SHALL BE MAINTAINED AT ALL TIMES BY UTILIZING STAGE CONSTRUCTION.

NO SALVAGE OF EXISTING STRUCTURE.

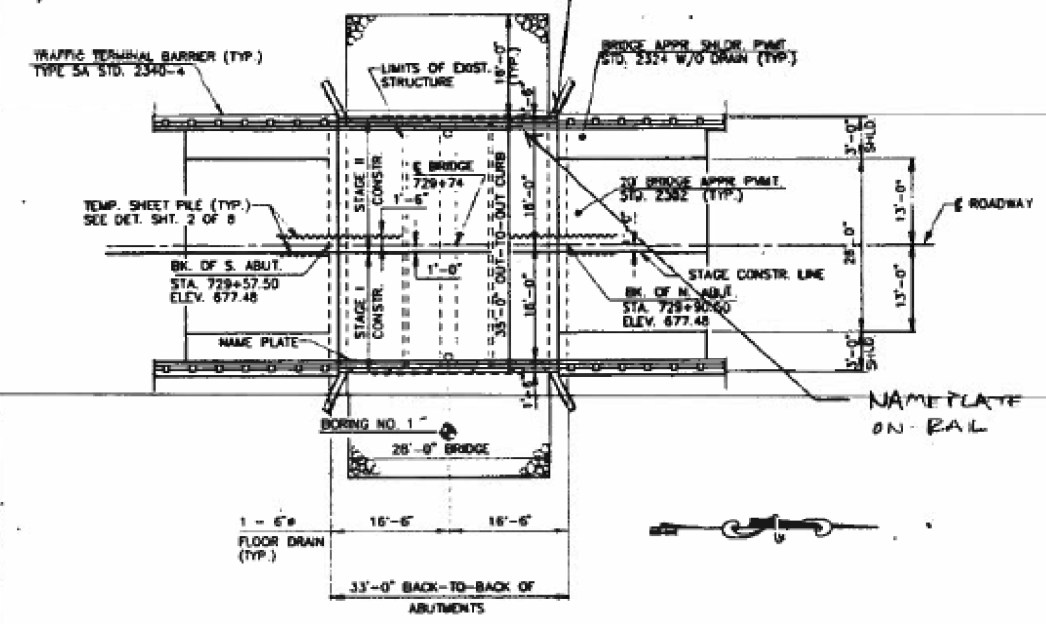

PLAN

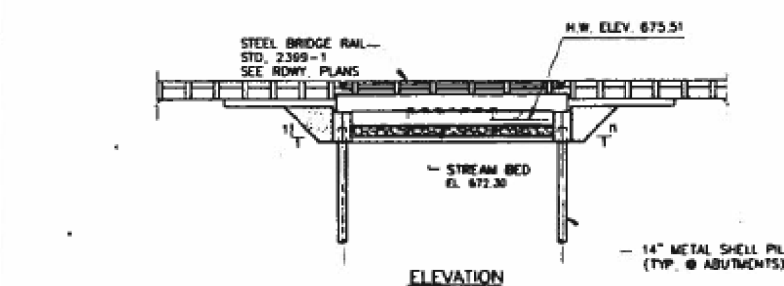

ELEVATION

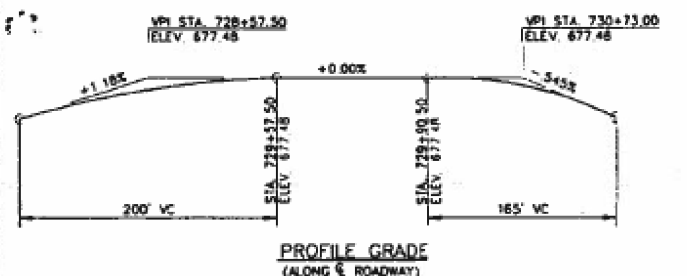

PROFILE GRADE
(ALONG E ROADWAY)

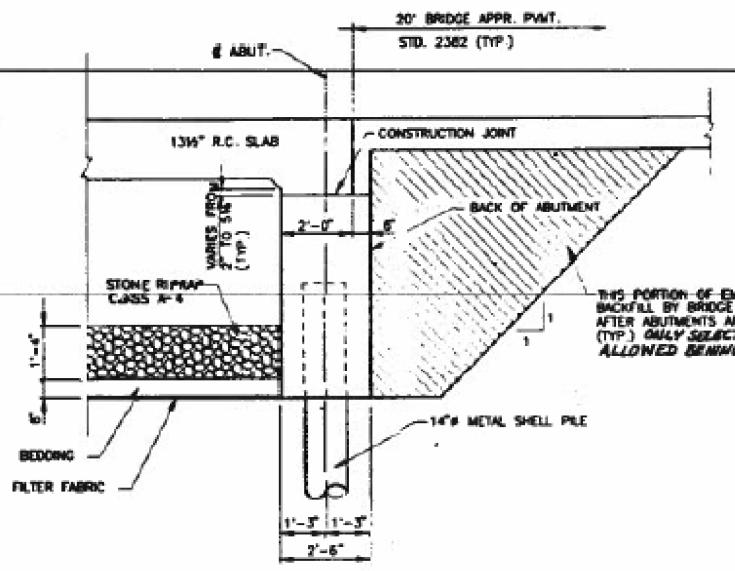

ABUTMENT SECTION AND STONE RIPRAP DETAIL

GENERAL NOTES

REINFORCEMENT BARS SHALL CONFORM TO THE REQUIREMENTS OF AASHTO M-31, M-42 OR M-53 GRADE 60.

LAYOUT OF STONE RIPRAP MAY BE VARIED IN THE FIELD TO SUIT GROUND CONDITIONS AS SHOWN ON ROADWAY PLANS OR AS DIRECTED BY THE ENGINEER.

THE CONTRACTOR SHALL DRIVE ONE METAL SHELL TEST PILE IN A PERMANENT LOCATION AT SOUTH ABUTMENT AS DIRECTED BY THE ENGINEER BEFORE ORDERING THE REMAINDER OF PILES.

THE EARTH EXCAVATION BETWEEN EXISTING CULVERT AND THE NEW ABUTMENT IS INCIDENTAL TO THE "REMOVAL OF EXISTING STRUCTURES" FOR PAVEMENT REMOVAL BETWEEN NEW ABUTMENTS SEE ROADWAY PLANS.

THE CONTRACTOR SHALL MAKE ALLOWANCE FOR THE DEFLECTION OF FORMS, SHRINKAGE AND SETTLEMENT OF FALSEWORK, IN ADDITION TO ALLOWANCE FOR DEAD LOAD DEFLECTION.

TOTAL BILL OF MATERIAL

ITEM	UNIT	SUPER	SUB	TOTAL
REMOVAL OF EXIST. STRUCTURE NO.2	EACH	----	170	170
STRUCTURE EXCAVATION	CU. YD.	----	122	122
CLASS X CONC. SUPERSTRUCTURE	CU. YD.	52.7	---	52.7
CLASS X CONC.	CU. YD.	---	40.2	40.2
PROTECTIVE COATING	SQ. YD.	8.5	---	8.5
REINF. BARS (EPOXY COATED)	POUND	13901	3842	17743
FURNISHING METAL PILE SHELLS (14")	LIN. FT.	---	362	362
DRIVING AND FILLING SHELLS	LIN. FT.	---	362	362
TEST PILE METAL SHELL (14")	EACH	---	1	1
TEMPORARY SHEET PILING	SO. FT.	---	348	348
NAME PLATES	EACH	1	---	1
STEEL BRIDGE RAIL	LIN. FT.	64	---	64
STONE RIPRAP CLASS A-4	SO. YD.	---	187	187
FILTER FABRIC FOR USE WITH RIPRAP	SO. YD.	---	187	187
BRIDGE DECK GROOVING	SO. YD.	113	---	113
FLOOR DRAIN	EACH	2	---	2

* QUANTITY IS TOP AND INSIDE SURFACE OF CURB.

DESIGN SPECIFICATIONS
1989 AASHTO WITH 1990 INTERIM AS APPLICABLE AND 1983 SEISMIC GUIDE SPECIFICATIONS

LOADING HS 20-44
ALLOW 25 #/SQ. FT. FOR FUTURE WEARING SURFACE

DESIGN STRESSES
FIELD UNITS
f_c = 3,500 P.S.I.
f_y = 60,000 P.S.I. (REINF)

STATION 729+74
BUILT 19... BY
STATE OF ILLINOIS
F.A.P. RTE. 836 SEC. 1198-2
F.A. PROJ. 1198-2
LOADING HS20
STR. NO. 010-0269

NAME PLATE
SEE STD 2113

APPROVED
FOR STRUCTURE NO. 010-0269
11-15-71

WATERWAY INFORMATION

DRAINAGE AREA = 0.74 MI.² LOW GRADE ELEV. 676.37 @ STA. 726+00

FLOOD YR.	PREC. O C.F.S.	OPENING SQ. FT.	NAT. EXIST. PROP.	H.W.E. EXIST. PROP.	HEAD - FT. EXIST. PROP.	HEADWATER EL. EXIST. PROP.		
DESIGN	50	434	20	98	675.51	1.12	676.63	676.23
BASE	100	500	20	98	675.59	1.09	676.68	676.33
OVERTOPPING								
MAX. CALC.	500	655	20	98	675.77	1.01	676.78	676.48

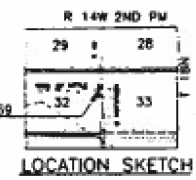

WELLS ENGINEERS, INC.

GENERAL PLAN
F.A.P. RTE. 836 OVER
TRIBUTARY TO LITTLE VERMILION RIVER
SEC. 1198-2
STATION 729+74
CHAMPAIGN COUNTY

STRUCTURE NO. 010-0269
DATE: 11-91 DRAWN BY: SDW JOB NO. 901202
DESIGNED BY: SDW CHECKED BY: JAF SHEET NO. 1

MODEL: 1400269.DWG FILE: 1400269.DWG PROJECT: 1198-2 CHAMPAIGN COUNTY ILLINOIS

USER NAME = PiersonJ	DESIGNED -	REVISED -
PLOT SCALE = 40.0000 "/> <td>DRAWN -</td> <td>REVISED -</td>	DRAWN -	REVISED -
PLOT DATE = 3/22/2019	CHECKED -	REVISED -
	DATE -	REVISED -

STATE OF ILLINOIS
DEPARTMENT OF TRANSPORTATION

AS-BUILT PLANS (INFORMATION ONLY)	
S.N. 010-0269	
SCALE: NONE	SHEET 1 OF 3 SHEETS
STA.	TO STA.

F.A.P. RTE.	SECTION	COUNTY	TOTAL SHEETS	SHEET NO.
836	**		214	63
CONTRACT NO. 70D56				
ILLINOIS FED. AID PROJECT				

ROUTE NO.	SECTION	COUNTY	TOTAL SHEETS	SHEET NO.
F.A.P. 836	119 B-2	CHAMPAIGN	39	20
FED. ROAD DIST. NO. 7	ILLINOIS	FED. AID PROJECT		

SHEET NO. 5
OF 8 SHEETS

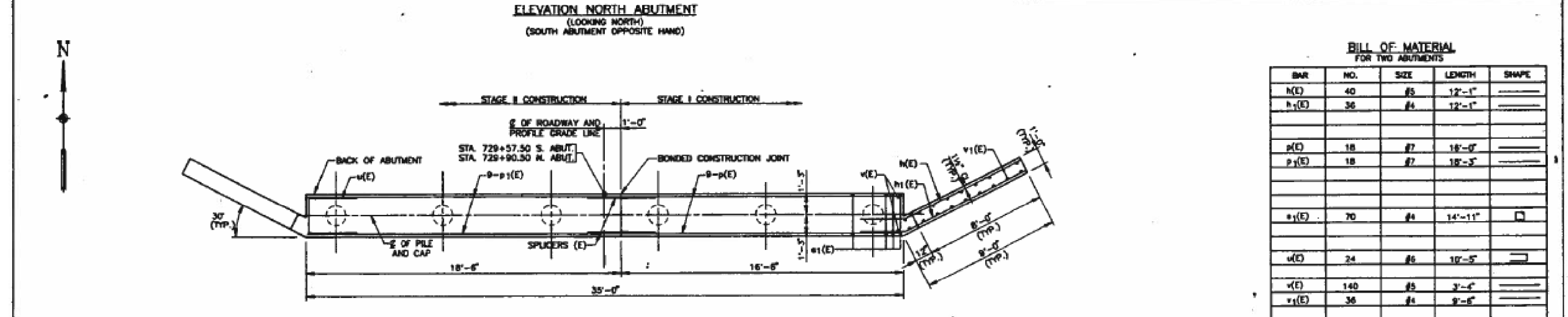
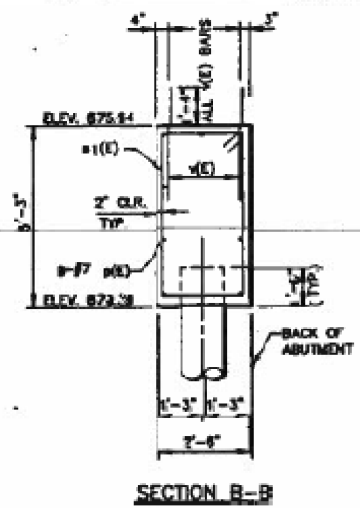
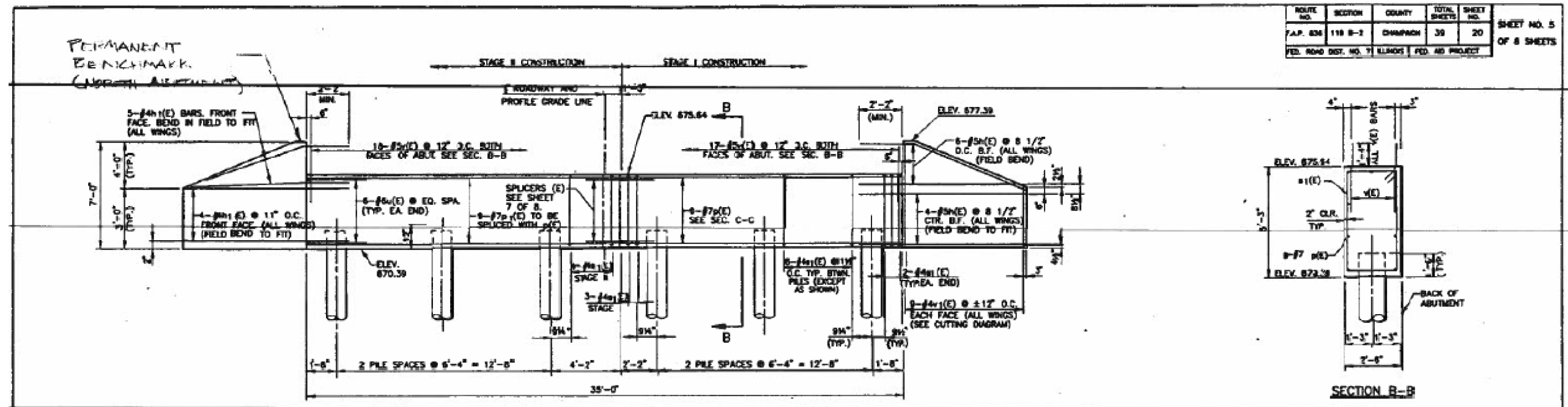

BILL OF MATERIAL FOR TWO ABUTMENTS

BAR	NO.	SIZE	LENGTH	SHAPE
n(E)	40	#5	12'-1"	—
h ₁ (E)	36	#4	12'-1"	—
p(E)	18	#7	18'-0"	—
p ₁ (E)	18	#7	18'-5"	—
s ₁ (E)	70	#4	14'-11"	□
u(E)	24	#6	10'-5"	—
v(E)	140	#5	3'-0"	—
v ₁ (E)	36	#4	8'-6"	—
CLASS X CONCRETE			CU. YD.	43.5
REINFORCEMENT BARS (EPOXY COATED)			LBS.	3850
FURNISHING METAL PILE SHELLS (14")			LN. FT.	363
DRIVING & FILLING SHELL			LN. FT.	363
STRUCTURE EXCAVATION			CU. YD.	172
TEST PILE METAL SHELL			EACH	1

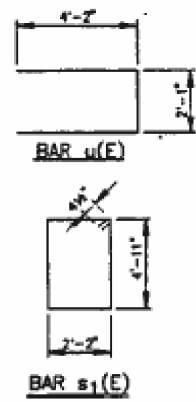
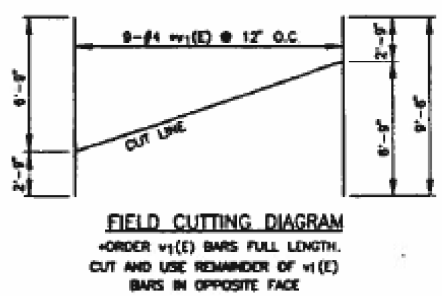

NOTES:

SEE SHEET 8 OF 8 FOR PILE DETAILS.

ALL EXPOSED EDGES SHALL HAVE STANDARD 3/8" CHAMFER UNLESS OTHERWISE NOTED.

BARS DESIGNATED (E) SHALL BE EPOXY COATED.

SEE SHEET 7 OF 8 FOR BAR SPICER (COUPLER) DETAILS.

PILE DATA:

TYPE: CONCRETE FILLED METAL SHELL (14")

CAPACITY: 50 TONS

EST. LENGTH: 33 FT.

NO. REQ'D: 11 + 1 TEST PILE

WELLS ENGINEERS, INC.

ABUTMENTS 1 AND 2
F.A.P. RTE. 836 OVER
TRIBUTARY TO LITTLE VERMILION RIVER
SEC. 119 B-2
STATION 729+74
CHAMPAIGN COUNTY

STRUCTURE NO. 010-0269

DATE: 11-01 DRAWN BY: SOW JOB NO. 901202
DESIGNED BY: SG CHECKED BY: JAF SHEET NO. 5

USER NAME = PiersonTJ	DESIGNED -	REVISED -
	DRAWN -	REVISED -
PLOT SCALE = 40,0000' / in.	CHECKED -	REVISED -
PLOT DATE = 3/22/2019	DATE -	REVISED -

**STATE OF ILLINOIS
DEPARTMENT OF TRANSPORTATION**

AS-BUILT PLANS (INFORMATION ONLY)

S.N. 010-0269

SCALE: NONE SHEET 2 OF 3 SHEETS STA. TO STA.

F.A.P. RTE.	SECTION	COUNTY	TOTAL SHEETS	SHEET NO.
836	119 B-2	CHAMPAIGN	39	20
CONTRACT NO. 70D56			ILLINOIS FED. AID PROJECT	

MODEL: S:\MODEL\NAMES
 FILE: N:\M:\S:\P\119B0269\DWG\010-0269.dwg
 PROJECT: S:\PROJECTS\70D56\010-0269.dwg
 OFFICE: CHAMPAIGN

ROUTE NO.	SECTION	COUNTY	TOTAL SHEETS	SHEET NO.
F.A.P. RTE.	1189-2	CHAMPAIGN	39	21
FED. ROAD DIST. NO. 7 ILLINOIS FED. AID PROJECT				

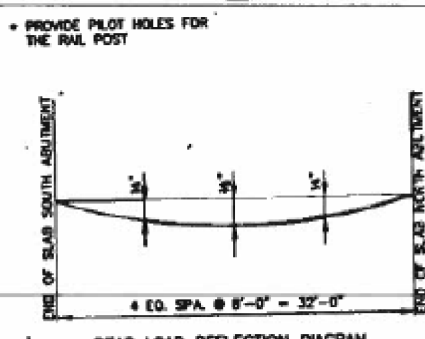
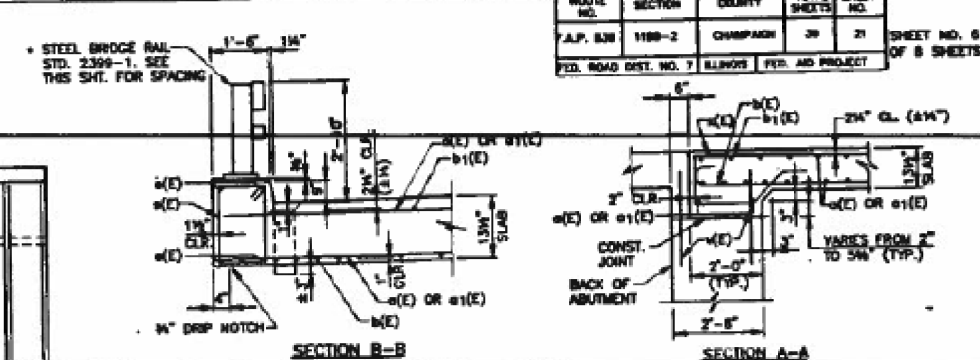
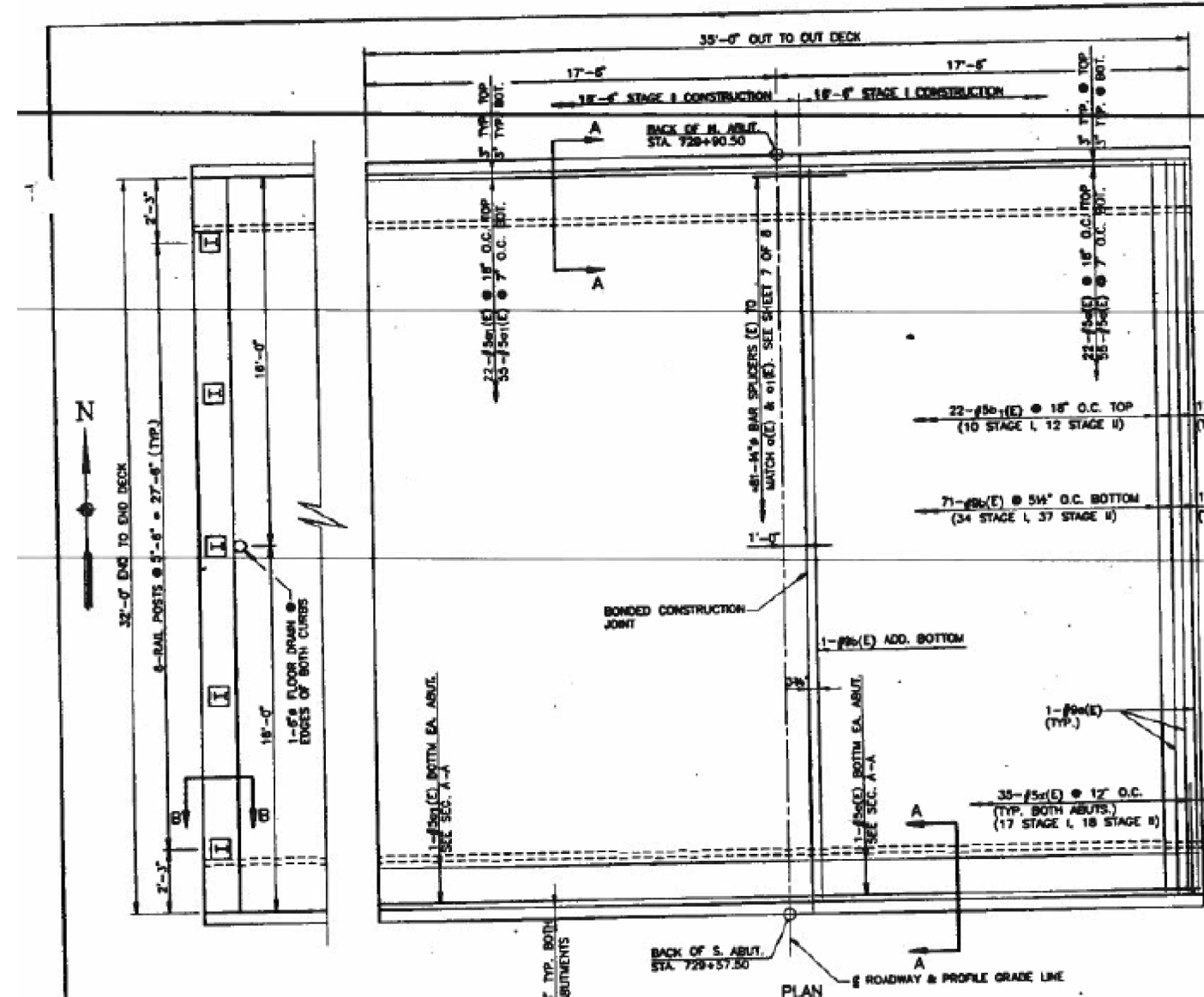

NOTES:
 ALL EXPOSED EDGES SHALL HAVE 1/4\"/>

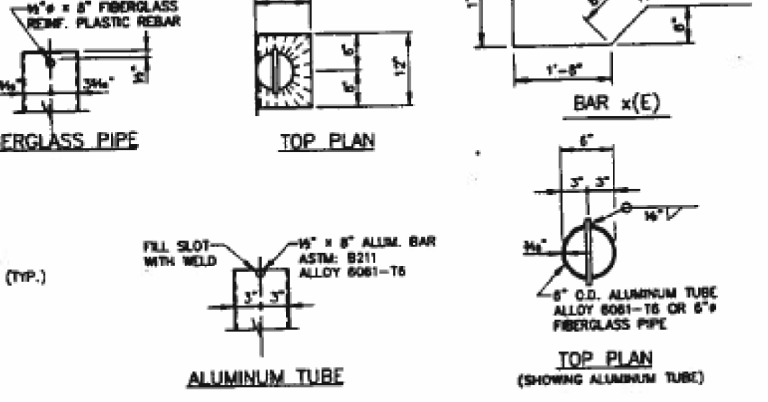
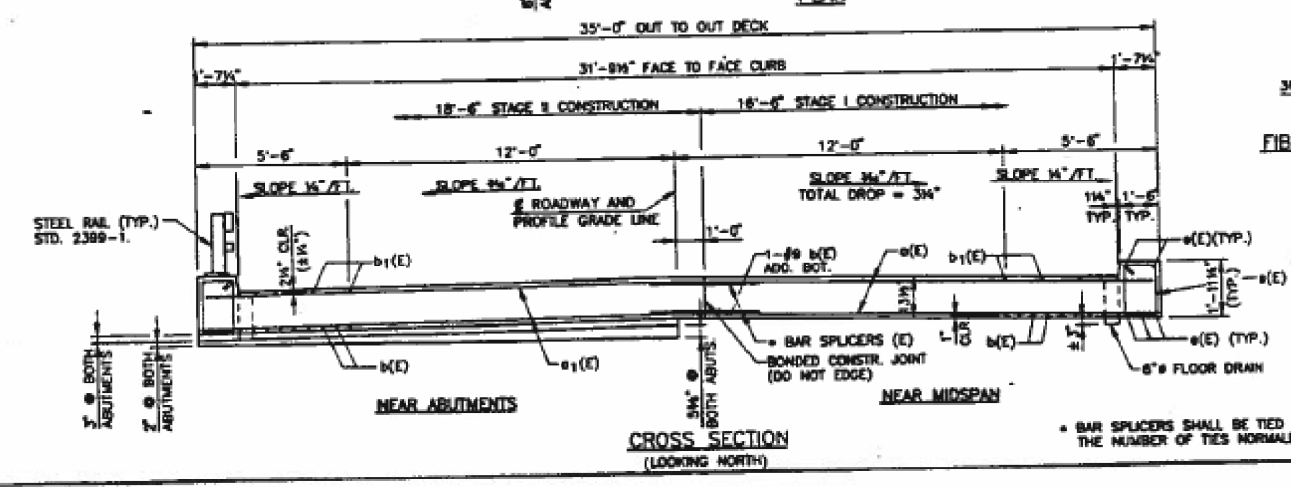

SUPERSTRUCTURE BILL OF MATERIALS

BAR NO.	SIZE	LENGTH	SHAPE
a(E)	11	75	18-3/4"
a1(E)	11	25	18-3/4"
b(E)	7/8	28	31-3/8"
b1(E)	7/8	25	31-3/8"
c(E)	10	29	31-3/8"
c1(E)	7/8	25	31-3/8"
d(E)	7/8	25	31-3/8"
d1(E)	7/8	25	31-3/8"
REINFORCING BARS (EPOXY COATED)		POUND	13,784
CLASS X CONCRETE SUPERSTRUCTURE		CU. YDS.	51.6
STEEL RAIL		LIN. FT.	64'-0"

WELLS ENGINEERS, INC.
 SUPERSTRUCTURE DETAIL
 F.A.P. RTE. 836 OVER
 TRIBUTARY TO LITTLE VERMILION RIVER
 SEC. 1189-2
 STATION 729+74
 CHAMPAIGN COUNTY
 STRUCTURE NO. 010-0269
 DATE: 11-01 DRAWN BY: SDW JOB NO. 901202
 DESIGNED BY: SG CHECKED BY: JAF SHEET NO. 6

MODEL: 1400269.DWG
 FILE: 1400269.DWG
 PROJECT: 1189-2 CHAMPAIGN COUNTY
 SHEET: 21 OF 39
 DATE: 11/01/2019
 DRAWN BY: SDW
 CHECKED BY: JAF
 DESIGNED BY: SG

USER NAME = PiersonJ	DESIGNED -	REVISED -
PLOT SCALE = 40.0000 "/>		

**STATE OF ILLINOIS
 DEPARTMENT OF TRANSPORTATION**

AS-BUILT PLANS (INFORMATION ONLY)		
S.N. 010-0269		
SCALE: NONE	SHEET 3 OF 3 SHEETS	STA. TO STA.

F.A.P. RTE.	SECTION	COUNTY	TOTAL SHEETS	SHEET NO.
836	**		214	65
CONTRACT NO. 70D56				
ILLINOIS FED. AID PROJECT				

EXISTING STRUCTURE: 10' X 4' CONCRETE BOX CULVERT
 BENCHMARK ELEV. = CHIS. "LJ" NE CORN. OF N. HEADWALL - 674.18
 BENCHMARK ELEV. = TRAVERSE STATION STA. 687+37.28 OFFSET 31.06 RT ELEV. 677.61

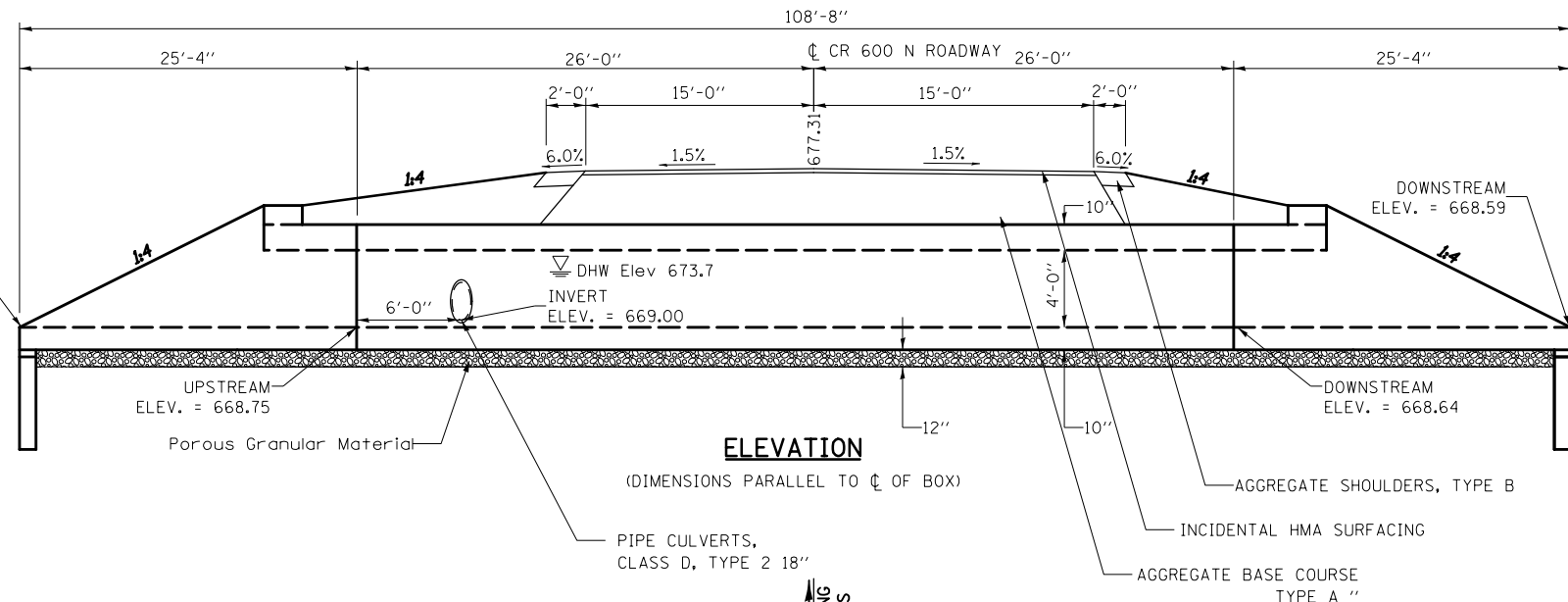

General Notes
 See 'Precast Box Culvert End Sections' for end section details. The design reinforcement for a 4 foot rise shall be used for A_{s1m}
 The design reinforcement areas for the Precast Concrete Box Culverts shall conform to those found in Table 1 of the AASHTO M 273 Specification for a 10' x 4' box section with a design fill height of 1.0 feet.
 The joints between precast box sections shall be sealed, all voids filled with a mastic joint sealer. In addition, the joints shall be externally sealed on all four sides with a 13 inch wide external sealing band. The seal shall be centered over the joint, secured in place and protected during the backfilling process.
 All dimensions are in FEET (') - INCHES (") unless otherwise noted.
 Drawings not to scale.

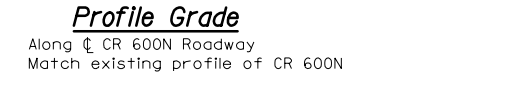

DESIGN SPECIFICATIONS
 2002 AASHTO
LOADING HS20-44
 Allow 50*/sq.ft. for future wearing surface
DESIGN STRESSES
FIELD UNITS
 $f'_c = 3,500$ psi
 $f_y = 60,000$ psi (reinforcement)
 $f_y = 65,000$ psi (welded wire fabric)
PRECAST UNITS
 $f'_c = 5,000$ psi
 $f_y = 65,000$ psi (welded wire fabric)

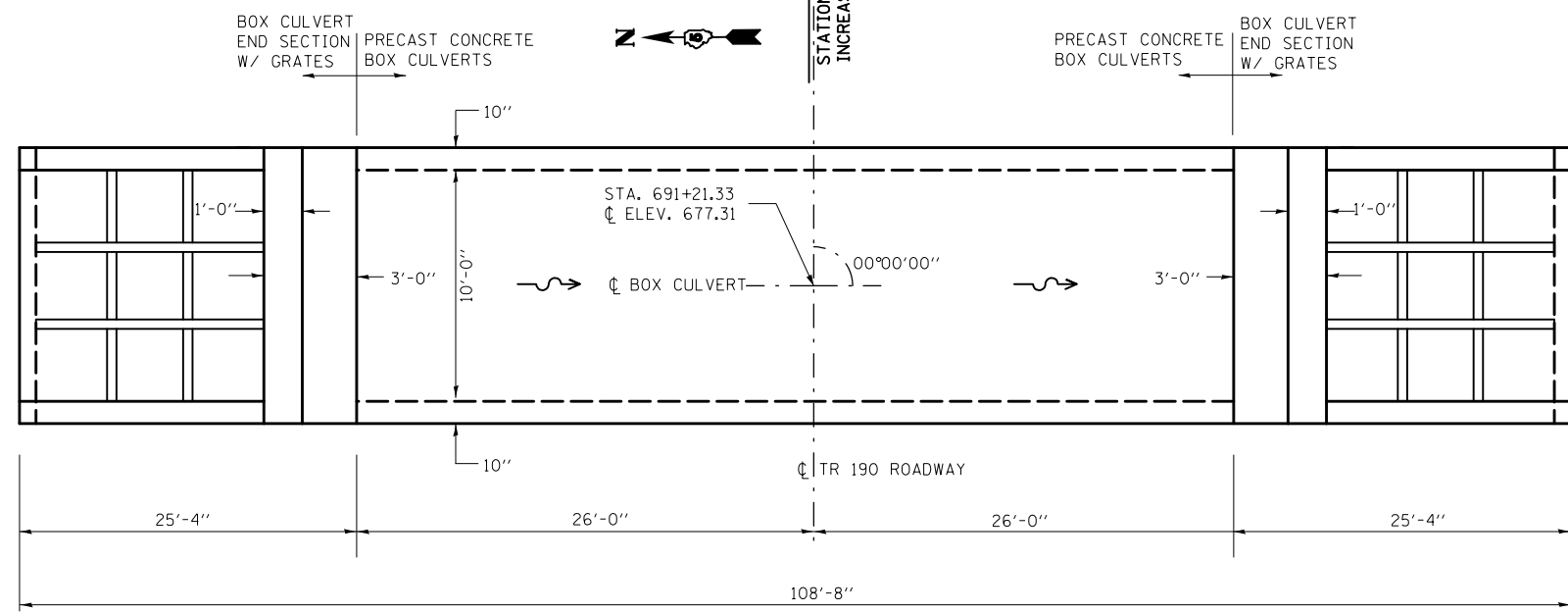

WATERWAY INFORMATION TABLE

Route:	FAP 836 (IL-49)	Existing S.N.:	N/A
Section:	118RS-3.119RS-4.D5 HSIP 2019-1	Proposed S.N.:	010-8176
County:	Champaign	Waterway:	Un-named
Date:	3/4/2019	By:	Eurnie Garver

CR 600 N		Existing Low Grade Elev. = 676.68		@ Sta. 691+21.33 Lt. 137.35'						
Drainage Area = 0.981 mi ²		Proposed Lo 676.68		@ Sta. 691+21.33 Lt. 137.35'						
Flood	Freq. Yr.	Q C.F.S.	Opening Sq. Ft.		Head - Ft.		Headwater Elevation			
			Existing	Proposed	Existing	Proposed	Existing	Proposed		
Design	10	154	36	36	672.4	0.3	0.4	672.7	672.8	
Base	50	214	40	40	673.0	0.7	0.7	673.7	673.7	
Max. Calc.	100	246	40	40	673.3	1.0	1.0	674.3	674.3	
	500	335	40	40	673.9	1.9	1.9	675.8	675.8	
					10 Year Outlet 3.9 fps		10 Year Outlet 4.27 fps			

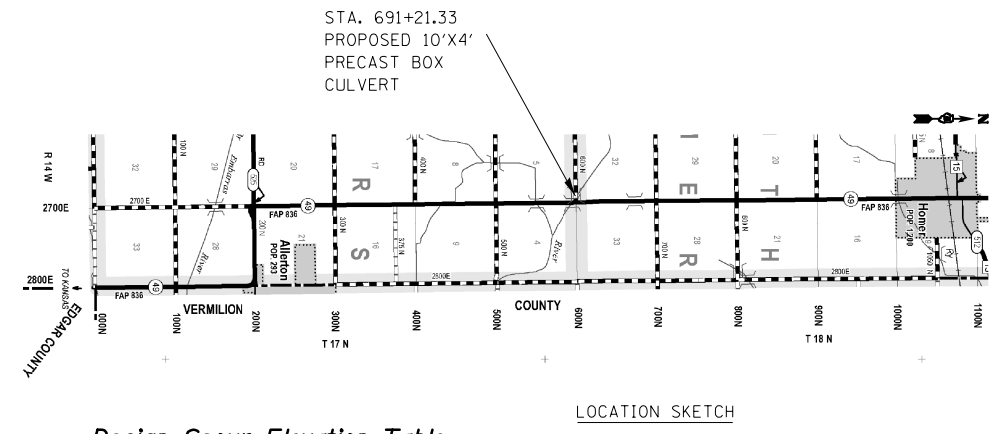

Design Scour Elevation Table

Design Scour Elevation (ft.)	Upstream	Downstream
	665.47	665.26

TOTAL BILL OF MATERIAL

Item	Unit	Total
PRECAST CONCRETE BOX CULVERTS 10' X 4'	Foot	52
BOX CULVERT END SECTIONS, CULVERT NO. 1	Each	2
TRAVERSABLE PIPE GRATE FOR CONCRETE END SECTION	FOOT	256
POROUS GRANULAR EMBANKMENT	CU YD	316

S.N. 010-8176
GENERAL PLAN AND ELEVATION
10'x4' PRECAST BOX CULVERT
F.A.P. ROUTE 836 - SECTION D5 HSIP 2019-1
CHAMPAIGN COUNTY
STATION 691+21.33

EXISTING STRUCTURE: 10' X 4' CONCRETE BOX CULVERT
 BENCHMARK ELEV. = CHIS. "LJ" SE CORN. OF S. HEADWALL
 BENCHMARK ELEV. = TRAVERSE STATION
 STA. 687+37.28
 OFFSET 31.06 RT
 ELEV. 677.61

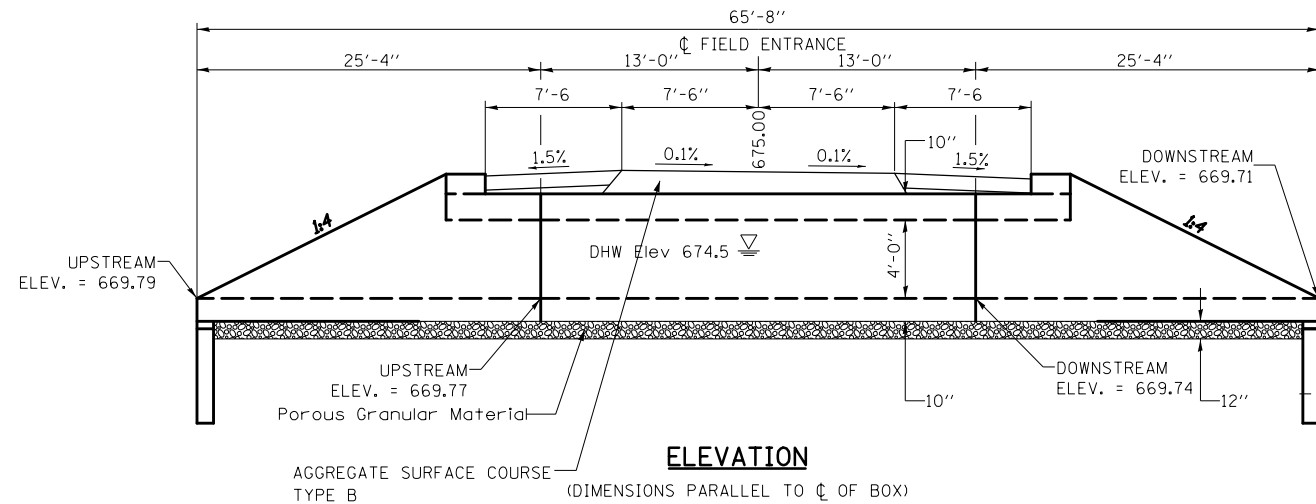

General Notes

See 'Precast Box Culvert End Sections' for end section details. The design reinforcement for a 4 foot rise shall be used for A_{s1} .

The design reinforcement areas for the Precast Concrete Box Culverts shall conform to those found in Table 1 of the AASHTO M 273 Specification for a 10' x 4' box section with a design fill height of 1.0 feet.

The joints between precast box sections shall be sealed, all voids filled with a mastic joint sealer. In addition, the joints shall be externally sealed on all four sides with a 13 inch wide external sealing band. The seal shall be centered over the joint, secured in place and protected during the backfilling process.

All dimensions are in FEET (') - INCHES (") unless otherwise noted.
 Drawings not to scale.

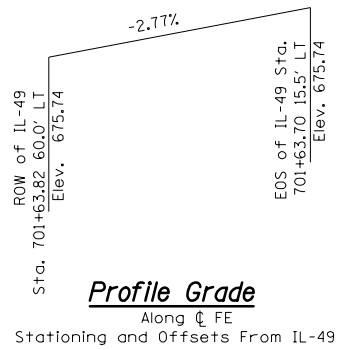

DESIGN SPECIFICATIONS
 2002 AASHTO

LOADING HS20-44
 Allow 50#/sq.ft. for future wearing surface

DESIGN STRESSES

FIELD UNITS
 f'_c = 3,500 psi
 f_y = 60,000 psi (reinforcement)
 f_y = 65,000 psi (welded wire fabric)

PRECAST UNITS
 f'_c = 5,000 psi
 f_y = 65,000 psi (welded wire fabric)

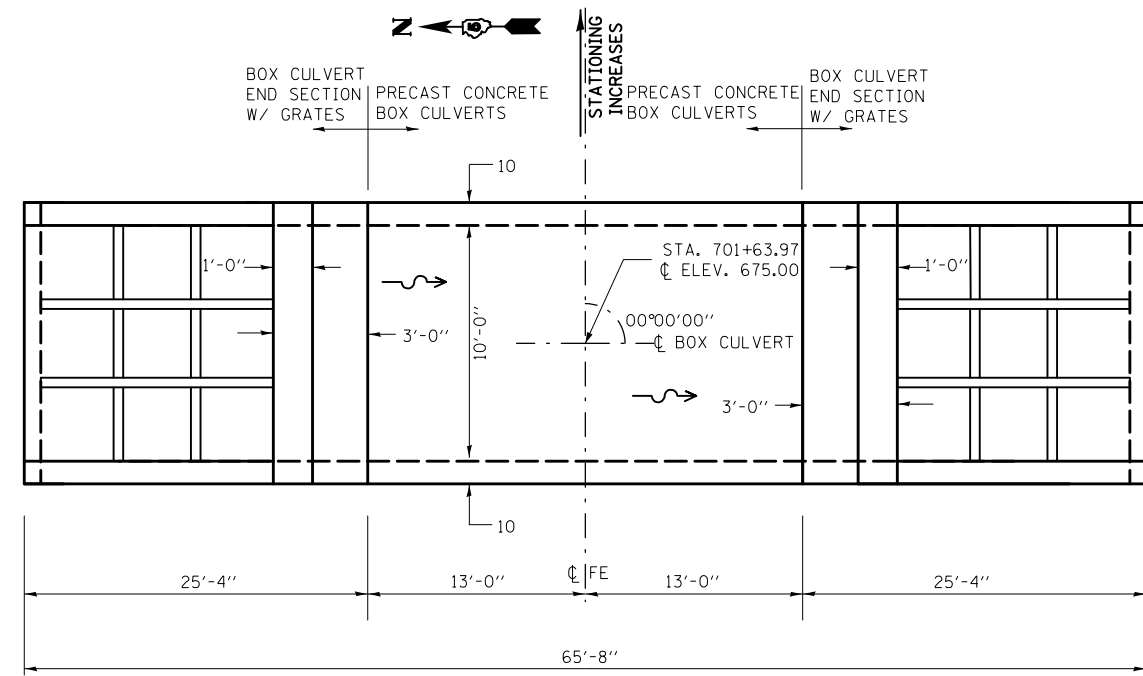

PLAN

WATERWAY INFORMATION TABLE

Route:	FAP 836 (IL-49)	Existing S.N.:	N/A
Section:	118RS-3.119RS-4.D5 HSIP 2019-1	Proposed S.N.:	010-8177
County:	Champaign	Waterway:	Un-named
Date:	3/4/2019	By:	Eunnie Garver

F.E.		Existing Low Grade Elev. = 674.68 @ Sta. 701+63.97 Lt. 61.6'		Proposed Lo 674.68 @ Sta. 701+63.97 Lt. 61.6'				
Drainage Area = 0.955 mi ²								
Flood	Freq. Yr.	Q C.F.S.	Opening Sq. Ft. Existing	Proposed	Head - Ft. Existing	Proposed	Headwater Elevation Existing	Proposed
	10	150	38	38	673.0	0.6	673.6	673.6
Design	50	208	40	40	673.6	0.9	674.5	674.5
Base	100	239	40	40	673.8	1.1	674.9	674.9
Overtopping Exist.	73	224	40		673.7	1.0	674.7	
Overtopping Prop.	65	219		40	673.7	1.0		674.7

10 Year Outlet 4.05 fps 10 Year Outlet 4.00 fps

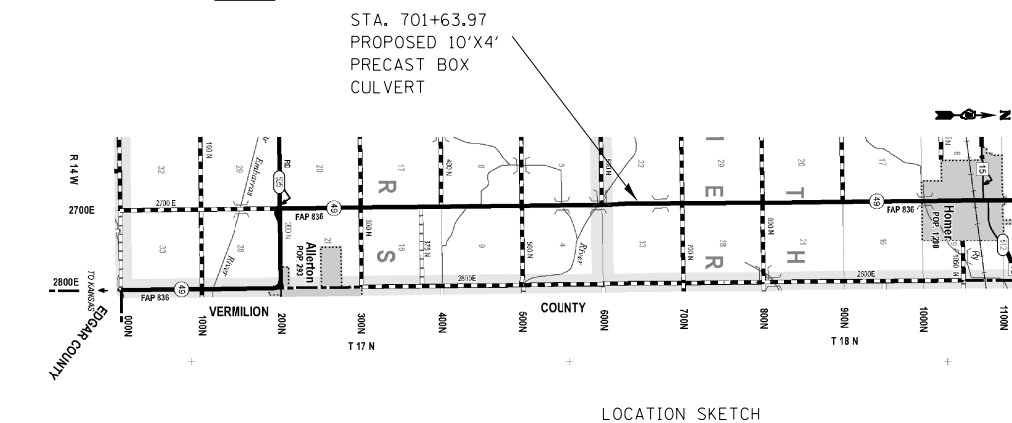

Design Scour Elevation Table

Design Scour Elevation (ft.)	Upstream	Downstream
	666.21	666.13

TOTAL BILL OF MATERIAL

Item	Unit	Total
PRECAST CONCRETE BOX CULVERTS 10' X 4'	Foot	26
BOX CULVERT END SECTIONS, CULVERT NO. 2	Each	2
TRAVERSABLE PIPE GRATE FOR CONCRETE END SECTION	FOOT	256
POROUS GRANULAR EMBANKMENT	CU YD	127

S.N. 010-8177

GENERAL PLAN AND ELEVATION
10'x4' PRECAST BOX CULVERT
F.A.P. ROUTE 836 - SECTION D5 HSIP 2019-1
CHAMPAIGN COUNTY
STATION 701+63.97

MODEL: \\MODEL\MARTE
 FILE: \\MARTE_Plan\118RS-3.119RS-4.D5\0556-CH-Culvert-Plan-and-Elevation.dgn
 PROJECT: \\PROJECTS\0556-CH-Culvert-Plan-and-Elevation.dgn
 DESIGNED: 3/4/2019
 DRAWN: 3/4/2019
 CHECKED: 3/4/2019
 DATE: 3/22/2019

USER NAME = PiersonTJ	DESIGNED -	REVISED -
	DRAWN -	REVISED -
PLOT SCALE = 40.0000' / in.	CHECKED -	REVISED -
PLOT DATE = 3/22/2019	DATE -	REVISED -

STATE OF ILLINOIS
DEPARTMENT OF TRANSPORTATION

GENERAL PLAN AND ELEVATION S.N. 010-8177		F.A.P. RTE.	SECTION	COUNTY	TOTAL SHEETS	SHEET NO.
FIELD ENTRANCE CULVERT STA 701+63.97 LT. 40.72		836	**	-	214	67
SCALE: N.T.S.		SHEET 1 OF 1 SHEETS		STA. TO STA.	CONTRACT NO. 70D56	

Pay Limits for Precast Concrete Box Culverts

Pay Limits for Box Culvert End Sections

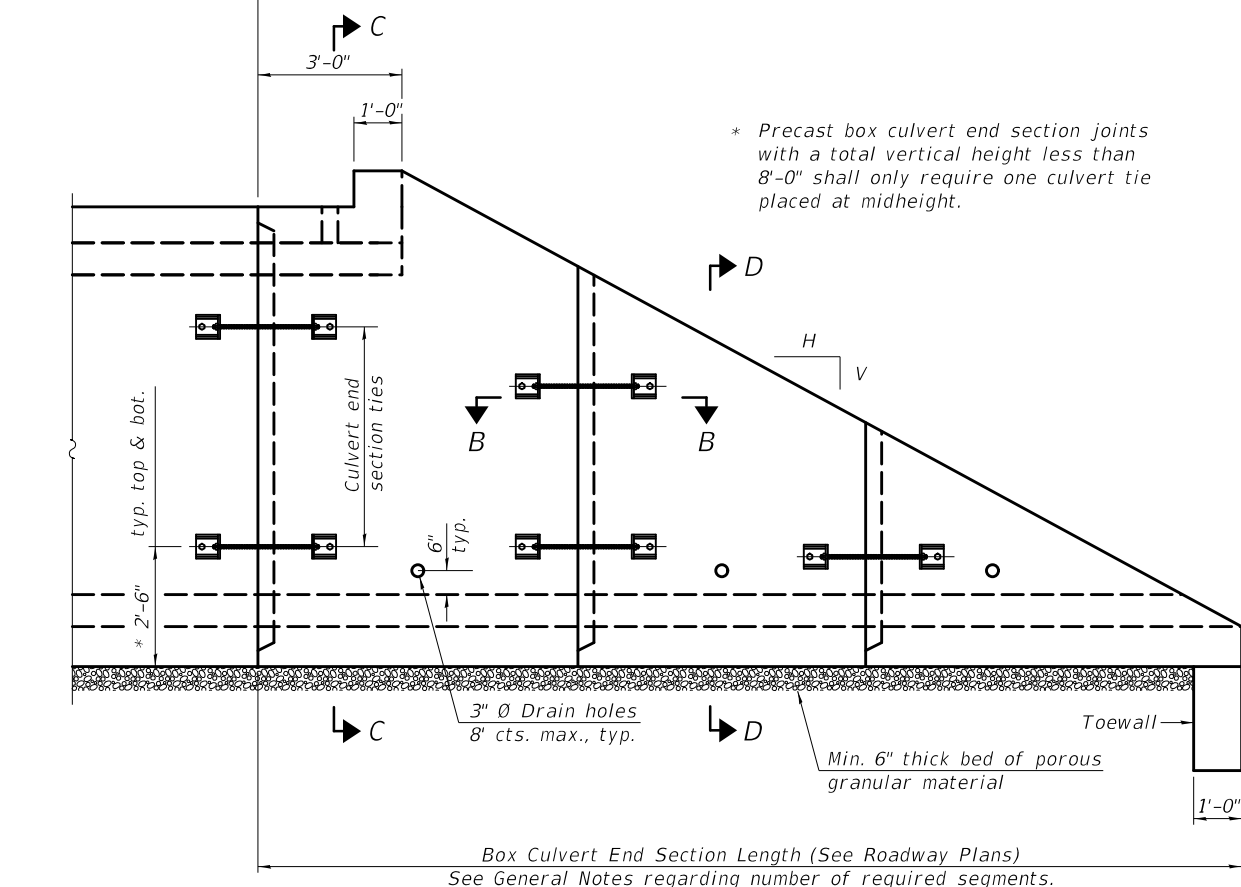

ELEVATION

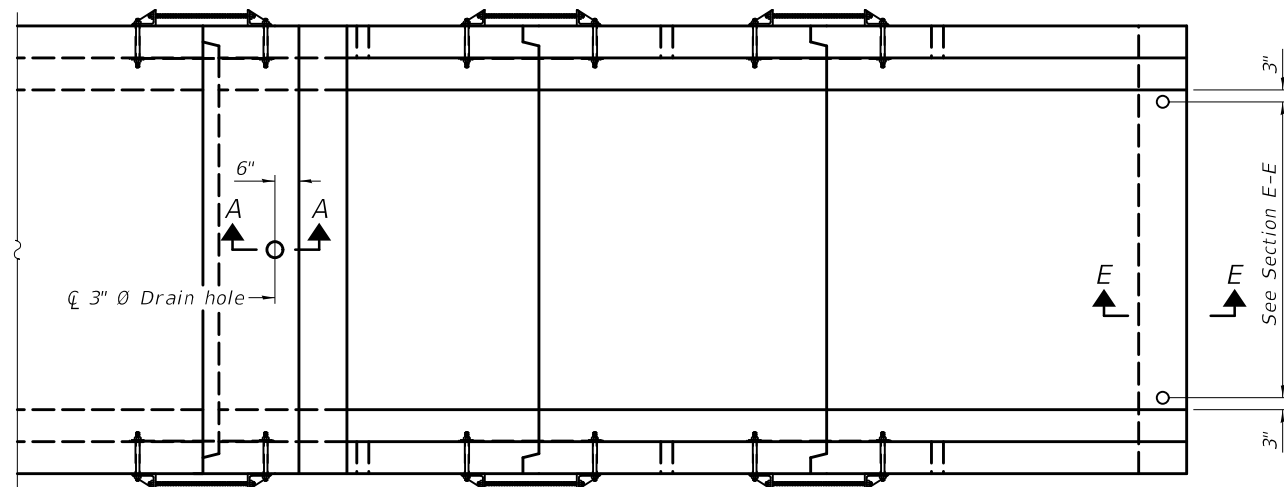

PLAN

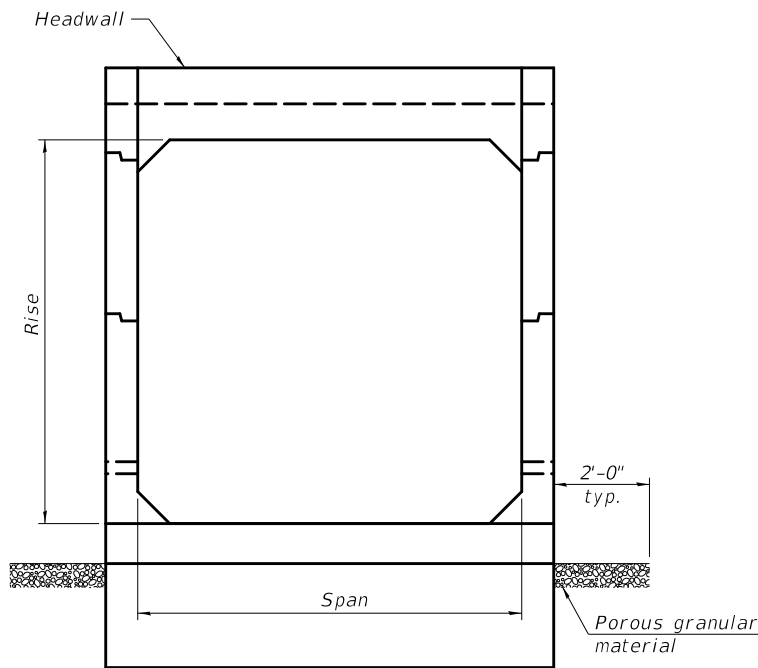

END VIEW

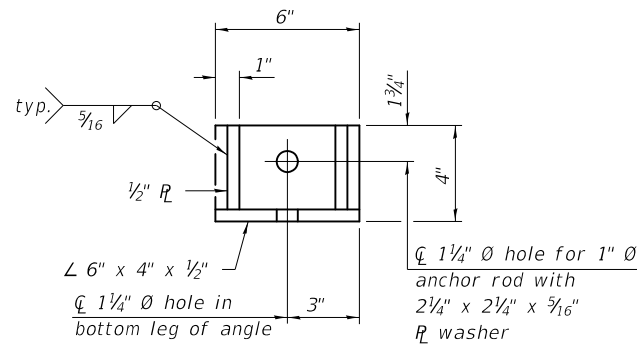

RESTRAINT ANGLE DETAIL

12" x 12" x 6" block of CA5, CA7, or CA11 coarse aggregate placed over drain opening. Block of aggregate shall be completely wrapped in nonwoven geotextile fabric.

Provide a double layer of 12" x 12" nonwoven geotextile fabric centered over the drain hole. Fabric shall be sealed to the concrete with mastic.

3" Ø PVC drain cast with the concrete (Adjust location to clear reinforcement).

1/2" Square foam blockout around PVC drain (to be removed with formwork)

SECTION A-A

(All costs associated with furnishing and constructing the above drain detail will not be measured for payment but shall be included in the contract unit price for the associated work.) (Sheet 1 of 2)

GENERAL NOTES

Box Culvert End Sections shall be constructed according to the requirements of Section 540 of the Standard Specifications except as modified herein. This work will be measured for payment as each, with each end of each culvert being one each. End sections will be paid for at the contract unit price per each for Box Culvert End Sections of the culvert number specified.

Typical box section dimensions, materials, and reinforcement details for Box Culvert End Sections shall be according to the requirements of ASTM C 1577 as required for the design of the portion of the culvert within the limits of Precast Concrete Box Culverts except as modified herein.

Number of segments shown in Elevation is for example only. Length and number of precast box sections required to construct Box Culvert End Sections shall be determined by the Contractor.

See roadway plans for embankment slope (V:H).

1" Ø anchor rods for the culvert ties shall conform to the requirements of ASTM F1554, Grade 105. Structural steel for tie plate and restraint angle shall conform to the requirements of Article 1006.04 of the Standard Specifications. All components of the culvert tie detail shall be galvanized according to the requirements of AASHTO M 111 or M 232 as applicable. 2 1/4" x 2 1/4" x 5/16" plate washers shall be provided under each nut required for the anchor rods. Anchor rods connecting precast sections shall be brought to a snug tight condition followed by an additional 1/2 turn on one of the nuts for anchor rods installed in the walls. Match marks shall be provided on the bolt and nut to verify relative rotation between the bolt and the nut. Holes in the walls for the culvert tie assembly may be drilled using core bits in lieu of using formed holes.

All costs associated with furnishing and installing or constructing the toewall and culvert ties will not be measured for payment but shall be included in the contract unit price for Box Culvert End Sections of the culvert number specified.

Drain holes shall conform to the requirements of Article 503.11 of the Standard Specifications unless noted otherwise.

Nonwoven geotextile fabric shall conform to the requirements of Article 1080.01. The minimum weight of the fabric shall be 6 oz. / sq. yd..

For end sections with traversable pipe grate systems, see grate detail sheet for required modifications.

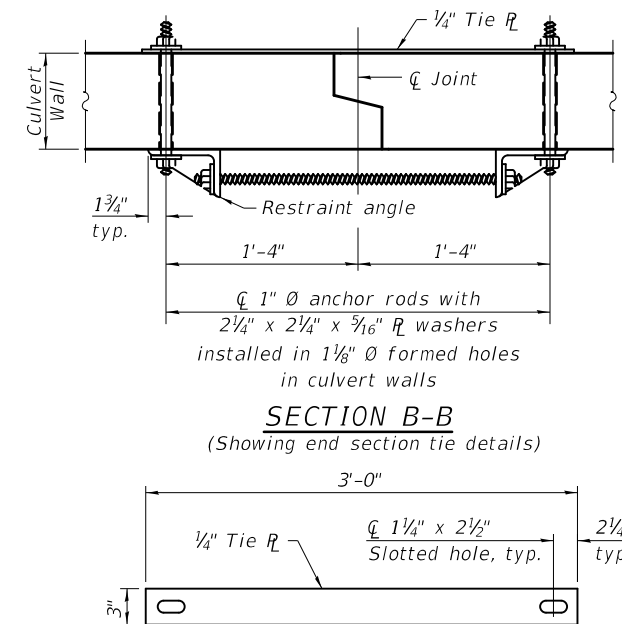

SECTION B-B

(Showing end section tie details)

TIE PLATE DETAIL

MODEL: I:\MODEL\MHFE... FILE: MHFE... PROJECT: I:\PROJECTS\05700558\CADD\Design\05700558-11-Detail\Culvert Plan and Elevation.dgn

SCB-TES

2-17-2017

USER NAME = PiersonTJ	DESIGNED -	REVISED -
DRAWN -	REVISED -	REVISED -
PLOT SCALE = 40.0000 ' / in.	CHECKED -	REVISED -
PLOT DATE = 3/22/2019	DATE -	REVISED -

**STATE OF ILLINOIS
DEPARTMENT OF TRANSPORTATION**

**SINGLE CELL PRECAST BOX CULVERT TAPERED END SECTIONS
STRUCTURE NO. 010-8176 AND 010-8177**

SCALE: N.T.S. SHEET 1 OF 2 SHEETS STA. TO STA.

F.A.P. RTE. 836	SECTION **	COUNTY -	TOTAL SHEETS 214	SHEET NO. 68
			CONTRACT NO. 70D56	
ILLINOIS FED. AID PROJECT				

**118RS-3,119RS-4,D5 HSIP 2019-1

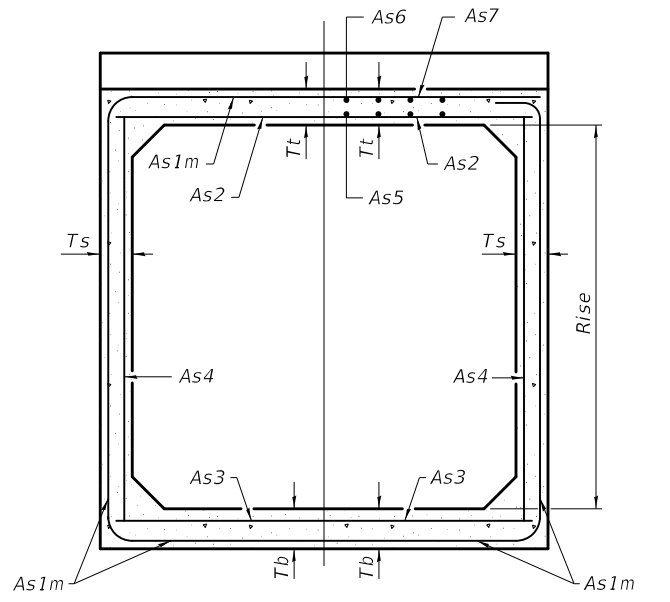

(Design Earth Cover \geq 2 ft) (Design Earth Cover < 2 ft)

SECTION C-C

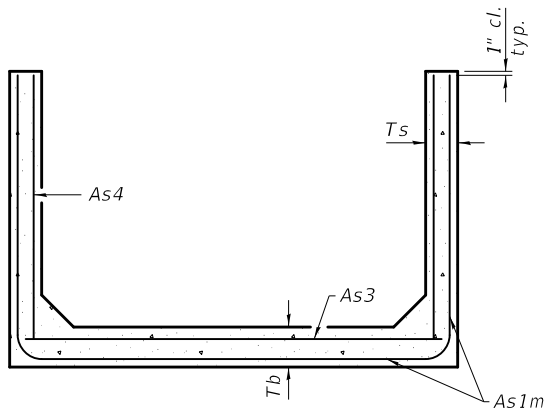

SECTION D-D

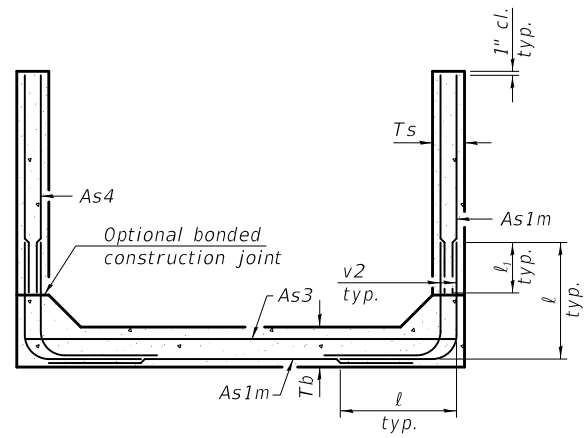

ALTERNATE SECTION D-D

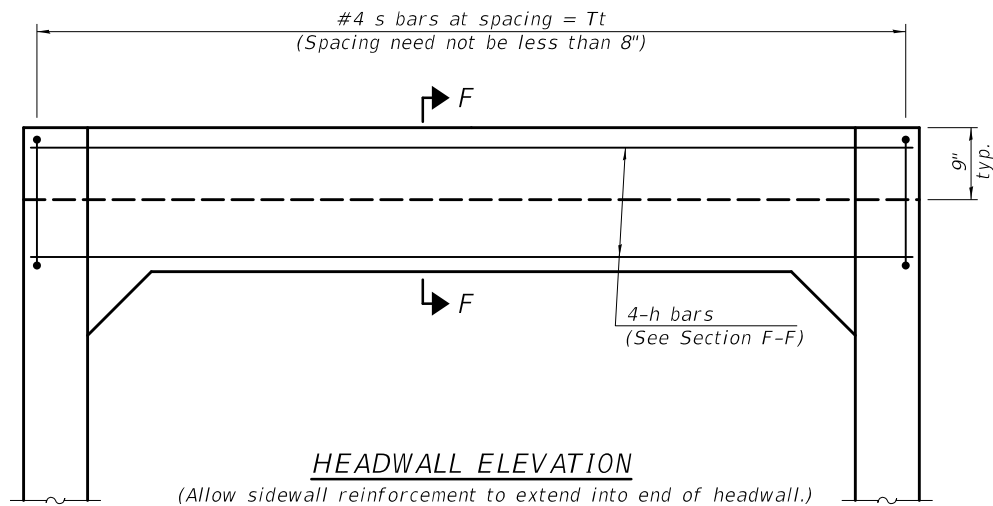

HEADWALL ELEVATION

(Allow sidewall reinforcement to extend into end of headwall.)

		As1m REINFORCEMENT											
		(in. ² / ft)											
Rise (ft)	Ts (in.)	2	3	4	5	6	7	8	9	10	11	12	
4	4	0.19	0.17										
5	5	0.26	0.21	0.18									
6	6	0.22	0.26	0.23	0.22								
7	7	0.25	0.33	0.59	0.27	0.28							
8	8	0.40	0.35	0.43	0.39	0.36	0.34	0.40					
9	9	0.44	0.39	0.35	0.43	0.40	0.37	0.36	0.48				
10	10	0.48	0.42	0.38	0.47	0.44	0.41	0.38	0.42	0.56			
11	11	0.52	0.45	0.54	0.50	0.46	0.44	0.41	0.46	0.50	0.65		
12	12	0.55	0.49	0.58	0.54	0.50	0.48	0.45	0.46	0.46	0.61	0.75	

(As1m reinforcement based upon welded wire reinforcement conforming to AASHTO M 55 or M 221)

l_i DIMENSION

- #3 bar = 2'-0"
- #4 bar = 2'-8"
- #5 bar = 3'-4"
- #6 bar = 3'-11"

Notes:
 Alternate Section D-D is provided to allow the Contractor the option of casting the bottom slab of the end section first followed by construction of the sidewalls using conventional forming methods. Shop drawings that detail slab thickness and reinforcement layout shall be submitted to the Engineer for review and approval when using Alternate Section D-D.
 The size and spacing of the v2 bars shall provide a minimum reinforcement area along each face of the walls (in.²/ft.) equal to 1.10*(As1m). v2 bars may consist of #3 thru #6 size reinforcement bars and the longitudinal spacing shall not exceed the lesser of the wall thickness or 8 inches.
 Bonded construction joints shall be prepared according to Article 503.09 of the Standard Specifications.

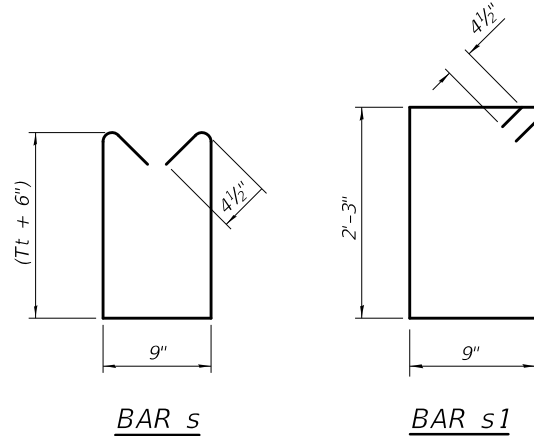

BAR s

BAR s1

TOEWALL CONSTRUCTION SEQUENCE

1. Perform excavation and construct toewall.
2. Backfill according to the applicable paragraphs of Article 502.10 of the Standard Specifications and place bedding for precast box culvert end sections.
3. Set precast box culvert end section.
4. Drill and epoxy grout reinforcement in toewall in accordance with Section 584 of the Standard Specifications.
5. Pressure grout voids using non-shrink grout conforming to Section 1024 of the Standard Specifications.

* The Contractor may furnish a precast or cast-in-place toewall. The Contractor shall be responsible for the strength and stability of the precast toewall during handling. Additional lifting points may be required depending upon the length of the toewall or the Contractor may need to modify the design of the toewall for the proposed handling method.

** If soil conditions permit, the sides of the toewall may be poured directly against the soil. The clear cover on the sides of the toewall shall be increased to 3" by increasing the thickness of the toewall.

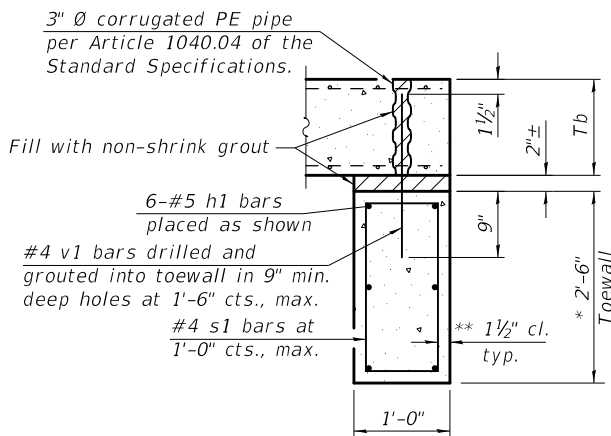

SECTION E-E

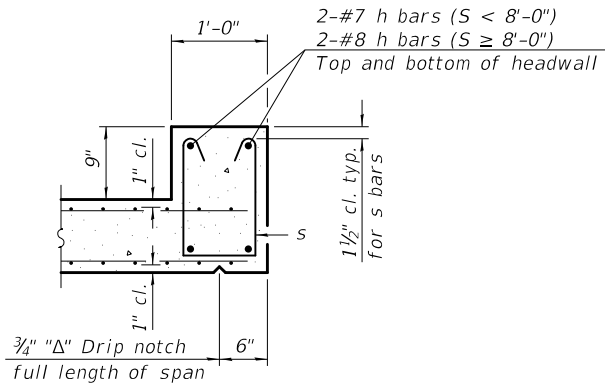

SECTION F-F

SCB-TES

2-17-2017

(Sheet 2 of 2)

USER NAME = PiersonTJ	DESIGNED -	REVISED -
	DRAWN -	REVISED -
PLOT SCALE = 40,0000 ' / in.	CHECKED -	REVISED -
PLOT DATE = 3/22/2019	DATE -	REVISED -

**STATE OF ILLINOIS
DEPARTMENT OF TRANSPORTATION**

**SINGLE CELL PRECAST BOX CULVERT TAPERED END SECTIONS
STRUCTURE NO. 010-8176 AND 010-8177**

F.A.P. RTE. 836	SECTION **	COUNTY -	TOTAL SHEETS 214	SHEET NO. 69
SCALE: N.T.S.		SHEET 2 OF 2 SHEETS	CONTRACT NO. 70D56	
STA. TO STA.		ILLINOIS FED. AID PROJECT		

**118RS-3,119RS-4,D5 HSIP 2019-1

MODEL: I:\MODEL\MHE\ FILE NAME: P:\pub\mhe\mhe.dwg PROJECT: D:\Projects\0570D56\SCB\Adda\Design\0570D56-ht-Detail\Culvert Plan and Elevation.dgn

GENERAL NOTES

The minimum edge distance from the center of a hole to the free edge of a structural shape or plate shall be 1 1/2" unless noted otherwise.
 This standard shall only be used on concrete end sections not skewed more than ±15 degrees with roadway.
 The Contractor may install the thru bolts using drilling and grouting in lieu of providing a formed hole using steel pipe. Installation shall be in accordance with Article 509.06 using a method that results in the annulus surrounding the bolt being completely filled with adhesive. The method of drilling shall not result in spalled concrete at the exit face. Epoxy grouted thru bolts shall be snug tightened followed by an additional 1/2 turn on the interior nut at final installation. Cost included with Traversable Pipe Grate.

Precast Box Culvert Dimensions			Slope of End Section	
S	R	Tt	1:4	
(ft)	(ft)	(in)	Longitudinal Pipe No. / Length	Transverse Pipe No. / Length
10	4	10	2 @ 20'-8"	9 @ 9'-7"

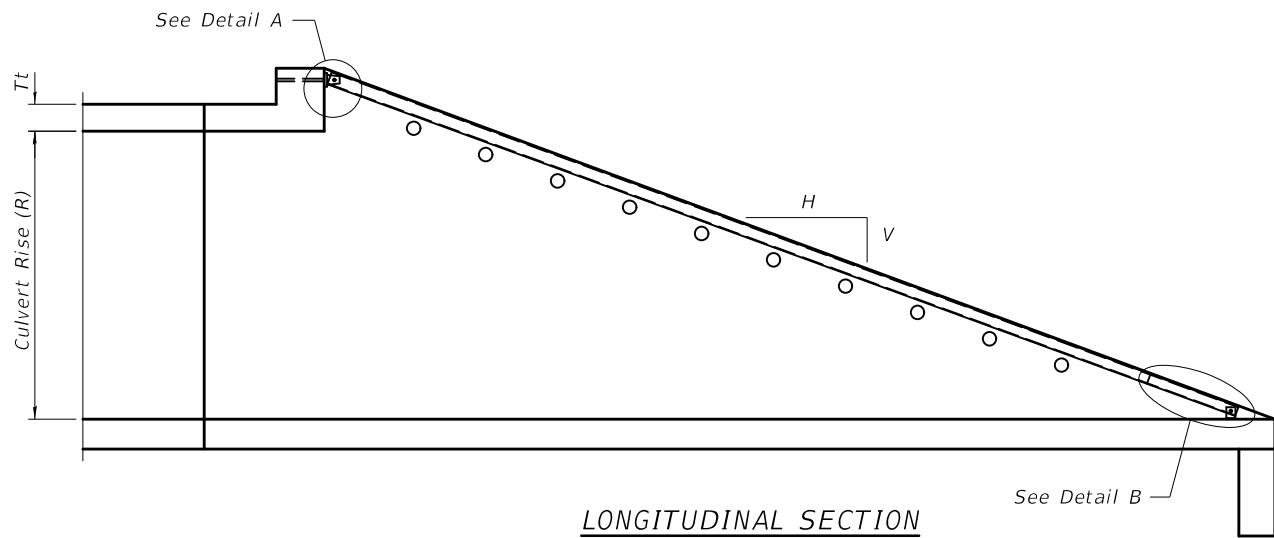

LONGITUDINAL SECTION

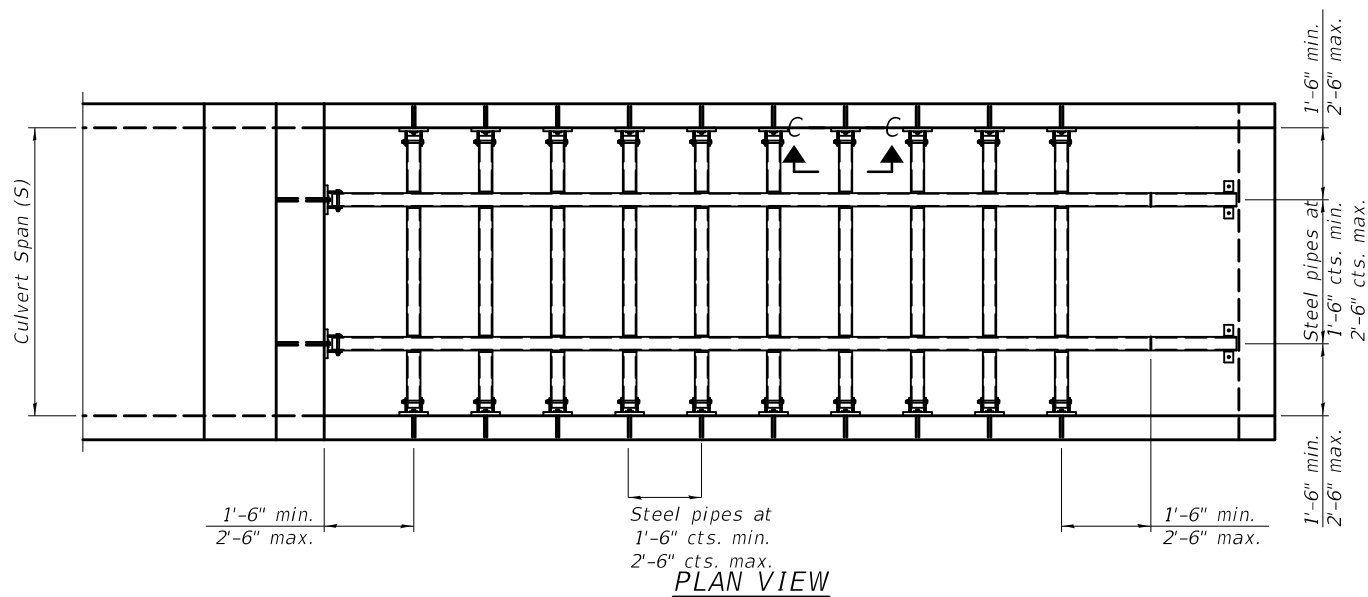

PLAN VIEW

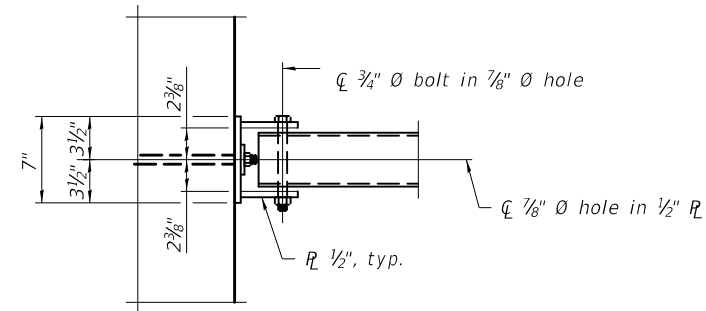

VIEW A-A

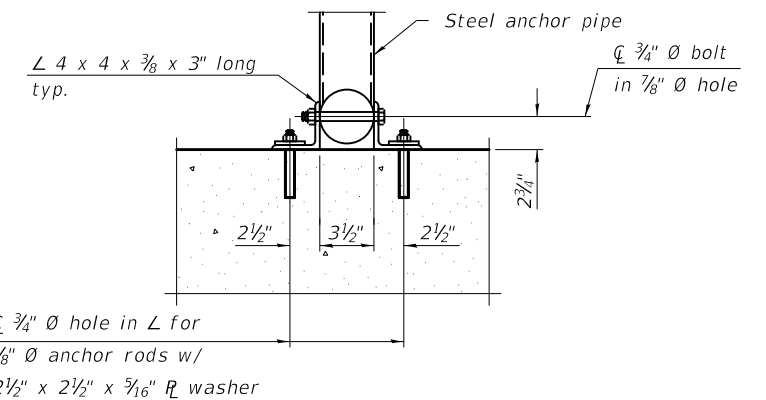

SECTION B-B

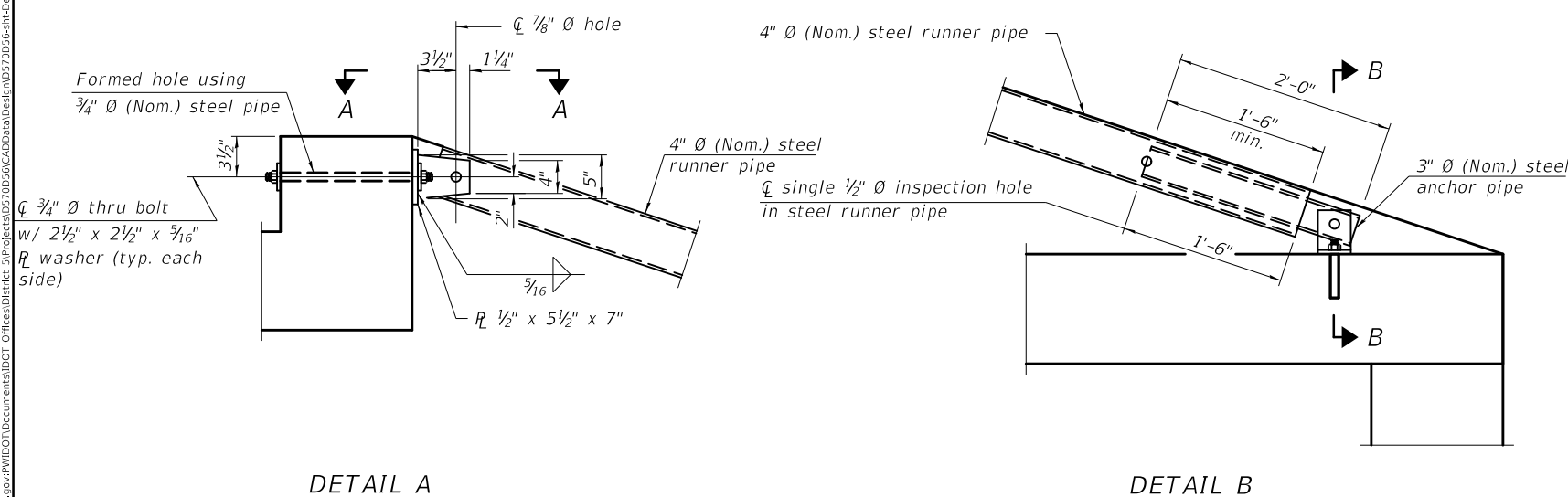

DETAIL A

DETAIL B

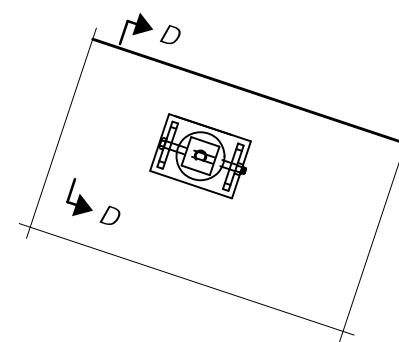

VIEW C-C

(See Detail A for dimensions and details not shown.)

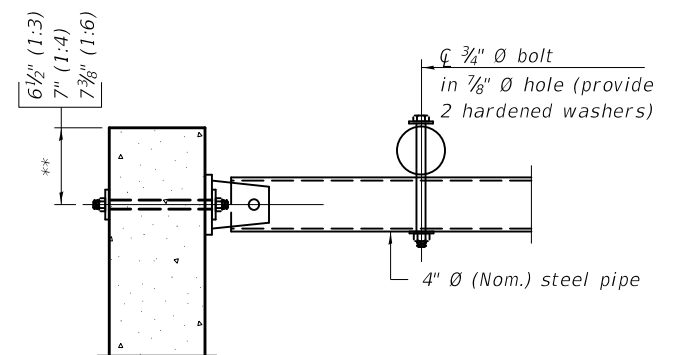

SECTION D-D

** Measured perpendicular to top of culvert wall. In addition, formed hole shall be located a minimum of 6" measured horizontally from any vertical joints necessary for construction of the culvert end section.

MODEL: T:\MODEL\MHFE... FILE: MHFE... TPGB-2S... 2-17-2017

TPGB-2S

2-17-2017

USER NAME = PiersonTJ	DESIGNED -	REVISED -
PLOT SCALE = 40.0000' / in.	DRAWN -	REVISED -
PLOT DATE = 3/22/2019	CHECKED -	REVISED -
	DATE -	REVISED -

**STATE OF ILLINOIS
DEPARTMENT OF TRANSPORTATION**

**TRAVERSABLE PIPE GRATE FOR BOX CULVERTS
STRUCTURE NO. 010-8176 AND 010-8177**

SCALE: N.T.S. SHEET 1 OF 1 SHEETS STA. TO STA.

F.A.P. RTE.	SECTION	COUNTY	TOTAL SHEETS	SHEET NO.
836	**	-	214	70
CONTRACT NO. 70D56				

**118RS-3,119RS-4,D5 HSIP 2019-1

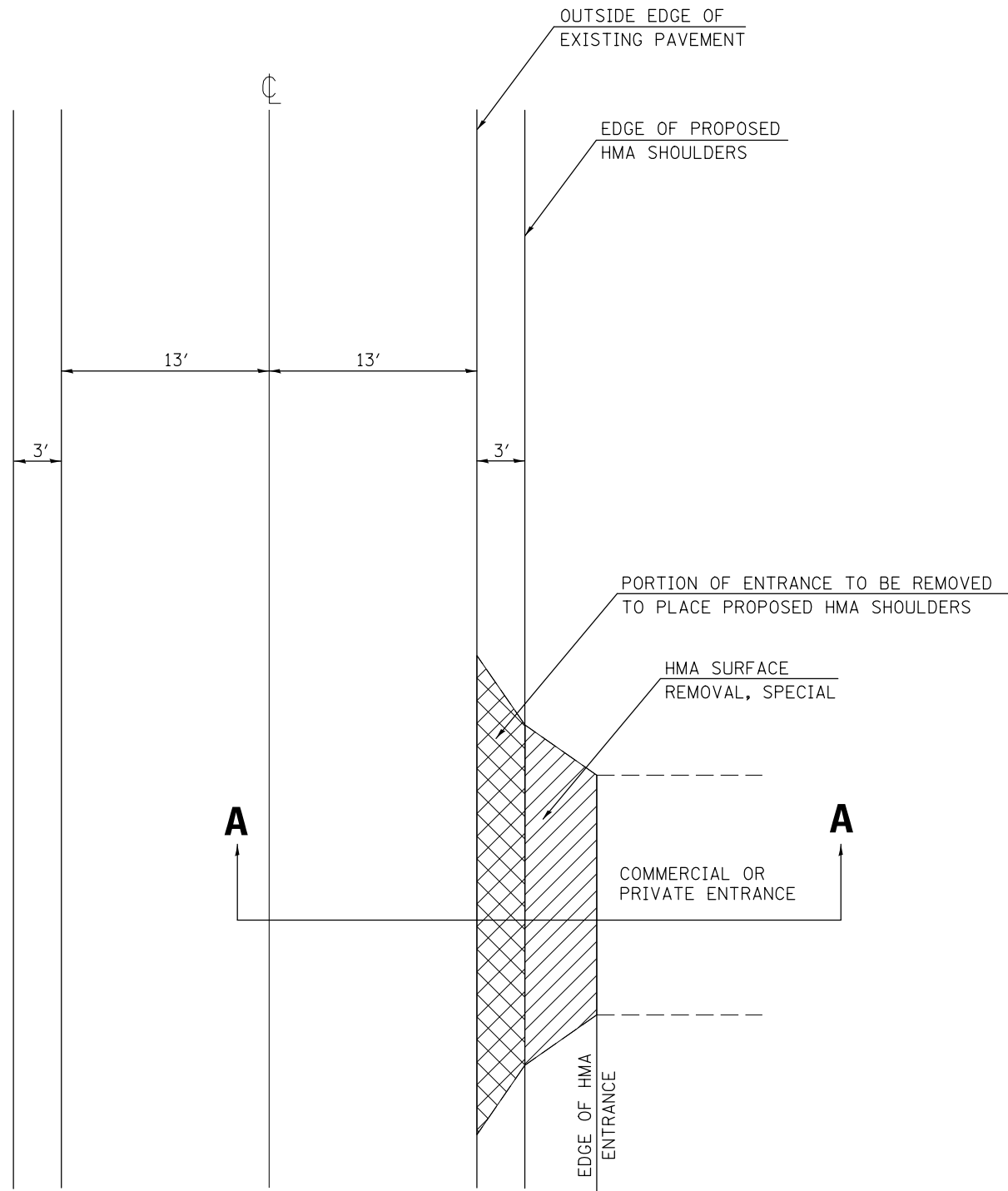

PLAN
NOT TO SCALE

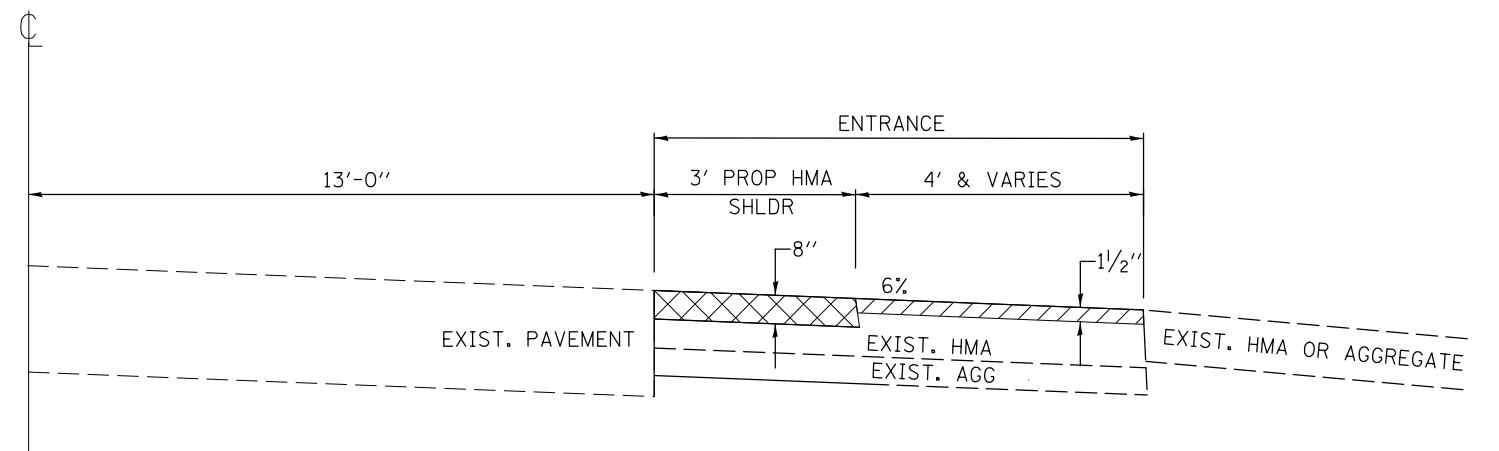

SECTION A-A
NOT TO SCALE



PAVEMENT REMOVAL



HMA SURFACE REMOVAL, SPECIAL & INCIDENTAL HMA SURFACE

MODEL: \\MODEL\MAME
 FILE: \\mame\p\pub\mcom\m\dat\illinois\gov\PIUIDOT\Documents\DOT_Offices\District_5\Projects\ID570D56\CADD\Drawn\Design\ID570D56-PI-DetailEntrance.dgn

USER NAME = PiersonJ	DESIGNED -	REVISED -
	DRAWN -	REVISED -
PLOT SCALE = 40,0000 ' / in.	CHECKED -	REVISED -
PLOT DATE = 3/22/2019	DATE -	REVISED -

**STATE OF ILLINOIS
DEPARTMENT OF TRANSPORTATION**

TYPICAL ENTRANCE DETAIL

SCALE: SHEET OF SHEETS STA. TO STA.

F.A.P. RTE. 836	SECTION **	COUNTY -	TOTAL SHEETS 214	SHEET NO. 71
			CONTRACT NO. 70D56	

**118RS-3,119RS-4,D5 HSIP 2019-1

*CHAMPAIGN & VERMILION

DIMENSION TABLE

STR. NO.	STATION	SIDE	Dimensions				No. h Bars	h Bar Length	No. d Bars	d Bar Length
			A	B	C	D				
N/A	440+21.57	LT	11'-0"	0'-6"	0'-4"	0'-7"	2	10'-8"	11	1'-1"
N/A	440+21.57	RT	11'-0"	0'-6"	0'-4"	0'-7"	2	10'-8"	11	1'-1"
N/A	773+98.35	LT	10'-0"	0'-10"	0'-4"	0'-5"	2	9'-8"	10	1'-5"
N/A	773+98.35	RT	10'-0"	0'-10"	0'-4"	0'-5"	2	9'-8"	10	1'-5"

BILL OF MATERIALS & BAR LIST

For Information Only

Bar	No.	Size	Shape
h	8	#5	————
d	42	#5	————

Item	Unit	Total
Concrete Box Culverts	Cu. Yd.	0.5
Reinforcement Bars	Pound	140.0

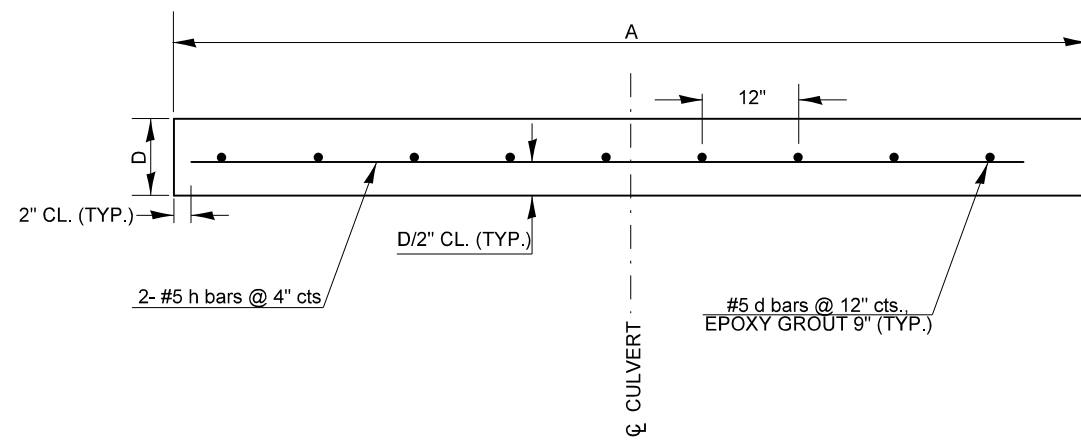

PLAN

NOT TO SCALE

NOTES:

- ALL EDGES SHALL HAVE STANDARD 3/4" CHAMFERS.
- CLASS SI CONCRETE SHALL BE USED THROUGHOUT.
- CONTRACTOR SHALL FIELD VERIFY ALL EXISTING BOX CULVERT HEADWALL DIMENSIONS PRIOR TO COMPLETING WORK.
- THE COST OF EPOXY GROUTING BARS SHALL BE INCLUDED WITH REINFORCEMENT BARS.
- REINFORCEMENT BARS SHALL CONFORM TO THE REQUIREMENTS OF ASTM A706 OR GR 60.
- PROTECTIVE COAT WILL NOT BE REQUIRED.
- THE EMBEDMENT DEPTH OF THE D BARS DIRECTLY ABOVE THE CULVERT OPENING SHALL BE REDUCED AS NECESSARY TO PREVENT DAMAGE TO THE EXISTING HEADWALL.
- INTENT: THE TOP OF THE PROPOSED HEADWALL SHALL BE LESS THAN 3" ABOVE THE ADJACENT PROPOSED AGGREGATE SHOULDER.

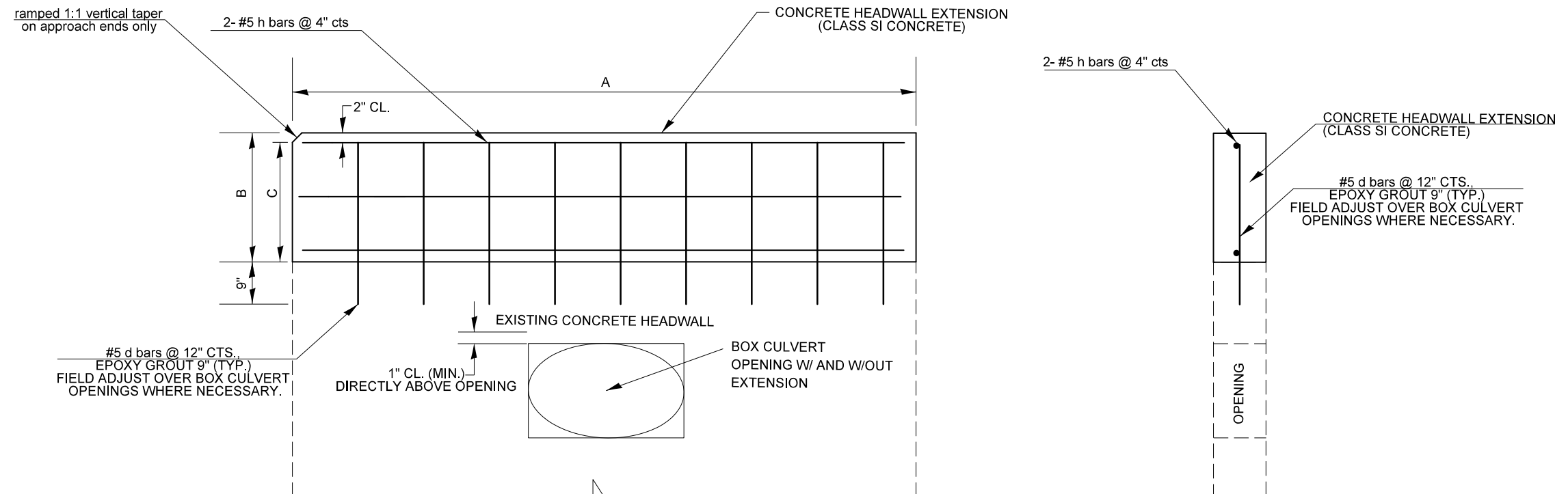

ELEVATION VIEWS

NOT TO SCALE

MODEL: I:\MODEL\NAMES... FILE: N:\nams... PROJECT: I:\PROJECTS\0570056\CADD\DATA\Design\0570056-RT-Details\Headwall_Extension_Modification.dgn

USER NAME = PiersonJ	DESIGNED -	REVISED -
	DRAWN -	REVISED -
PLOT SCALE = 40.0000' / in.	CHECKED -	REVISED -
PLOT DATE = 4/3/2019	DATE -	REVISED -

**STATE OF ILLINOIS
DEPARTMENT OF TRANSPORTATION**

HEADWALL MODIFICATION DETAIL

SCALE: N.T.S. SHEET 1 OF 1 SHEETS STA. TO STA.

F.A.P. RTE.	SECTION	COUNTY	TOTAL SHEETS	SHEET NO.
836	**	-	214	72
CONTRACT NO. 70D56				

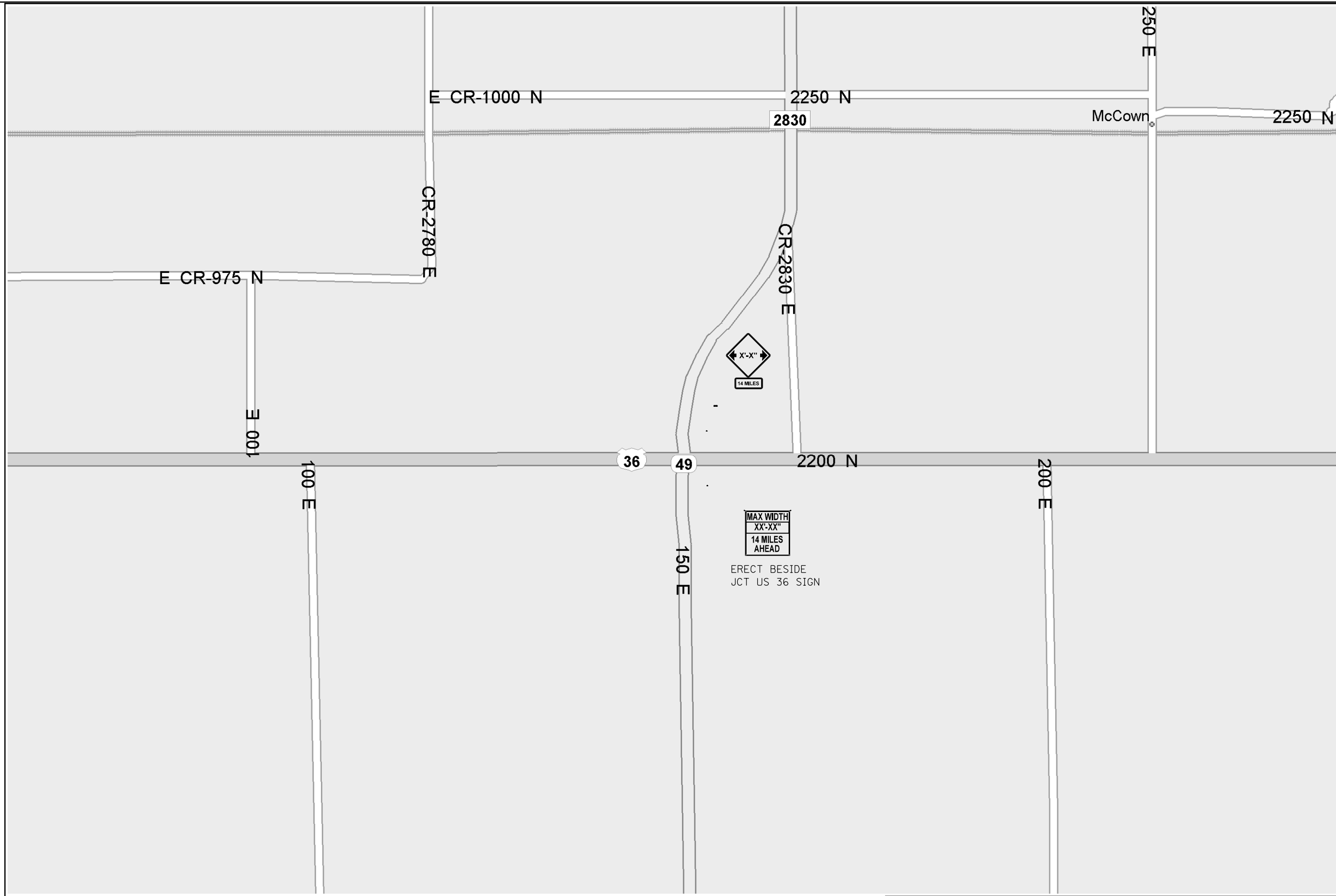

FILE NAME =	USER NAME = PiersonTJ	DESIGNED -	REVISED -
pw:\planroom.dot.illinois.gov\PIDOT\Documents\IDOT Offices\District 5\Projects\0570056\Drawings\Design\0570056-sh1-Detail-Width	DRAWN by	REVISION	on Map.dgn
MODELNAME	PLOT SCALE = 40.0000' / in.	CHECKED -	REVISED -
	PLOT DATE = 3/22/2019	DATE -	REVISED -

**STATE OF ILLINOIS
DEPARTMENT OF TRANSPORTATION**

WIDTH RESTRICTION DETAIL

SCALE: SHEET 1 OF 2 SHEETS STA. TO STA.

F.A.P. RTE.	SECTION	COUNTY	TOTAL SHEETS	SHEET NO.
836	**	*	214	73
			CONTRACT NO. 70D56	



FILE NAME =	USER NAME = PiersonTJ	DESIGNED -	REVISED -
p:\planroom.dot.illinois.gov\PIDOT\Documents\IDOT Offices\District 5\Projects\0570056\Drawings\Design\0570056-sh1-Detail-Width	pierson	pierson	pierson
\$MODELNAME\$	PLOT DATE = 3/22/2019	DATE -	REVISED -

**STATE OF ILLINOIS
DEPARTMENT OF TRANSPORTATION**

WIDTH RESTRICTION DETAIL			
SCALE:	SHEET 2	OF 2	SHEETS
STA.	TO STA.		

F.A.P. RTE.	SECTION	COUNTY	TOTAL SHEETS	SHEET NO.
836	**	*	214	74
ILLINOIS FED. AID PROJECT			CONTRACT NO. 70D56	

OPTION 1

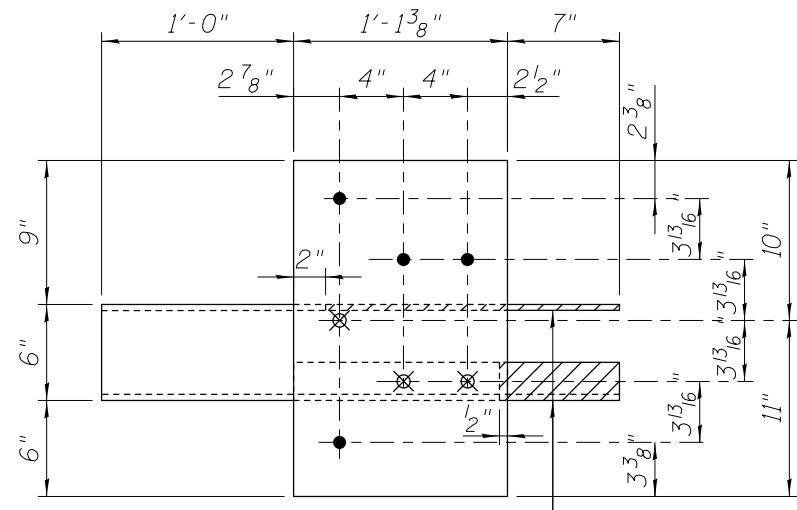

GUARDRAIL CONNECTION PLATE ASSEMBLY
(Modified from Std. 631032)

Hatched portions of $\frac{3}{8}$ " Plate and L 4 x 4 x $\frac{3}{8}$ shall be removed or omitted. If removed after galvanizing, the exposed bare metal shall be coated with an approved zinc rich paint.

OPTION 2

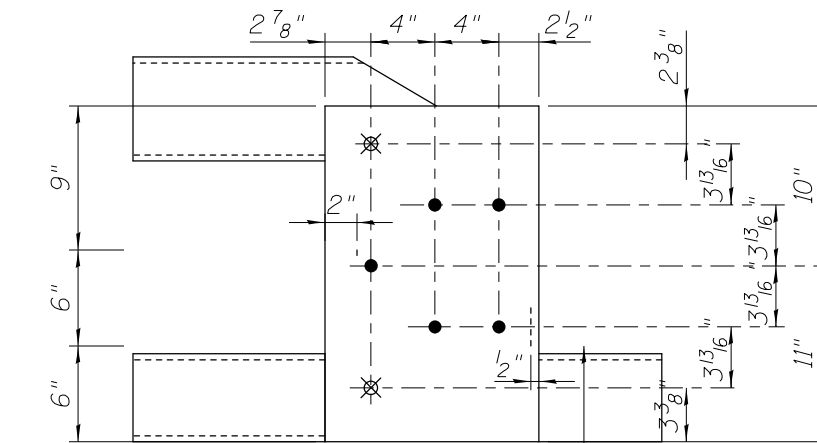

GUARDRAIL CONNECTION PLATE ASSEMBLY
(Modified from Std. 631032)

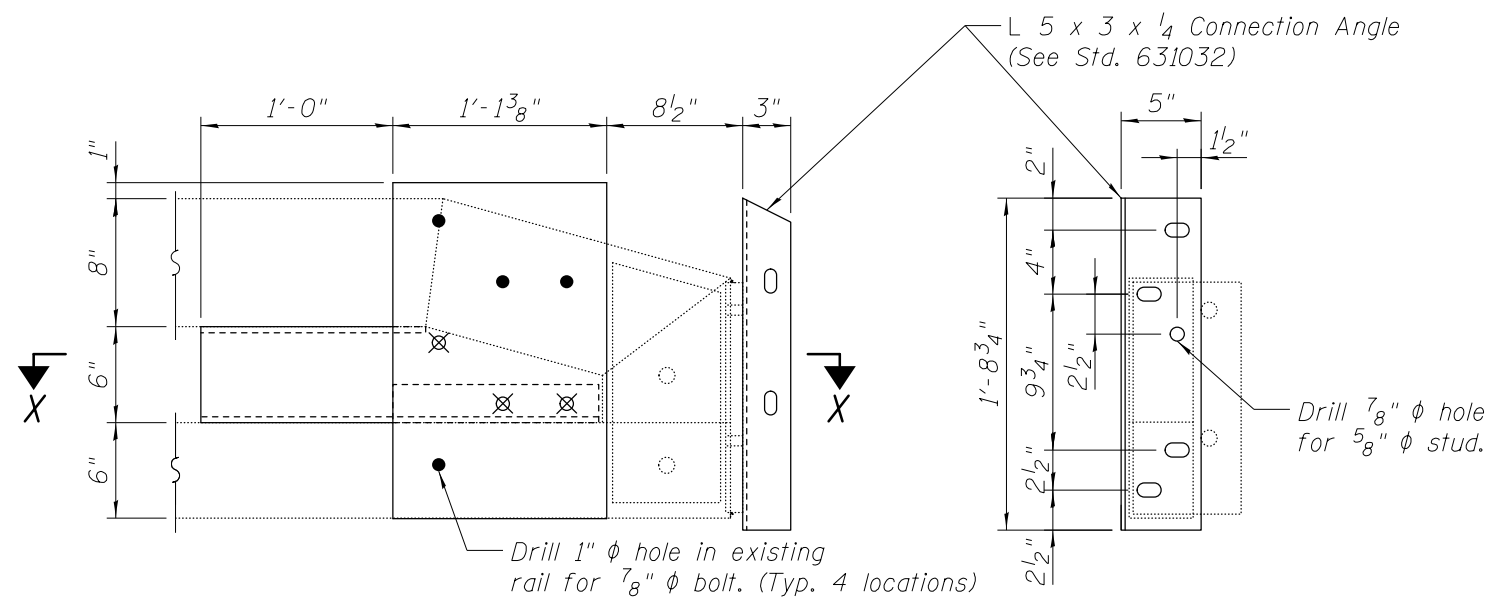

END OF RAIL DETAILS
(Typical at 2 corners of bridge)

END VIEW

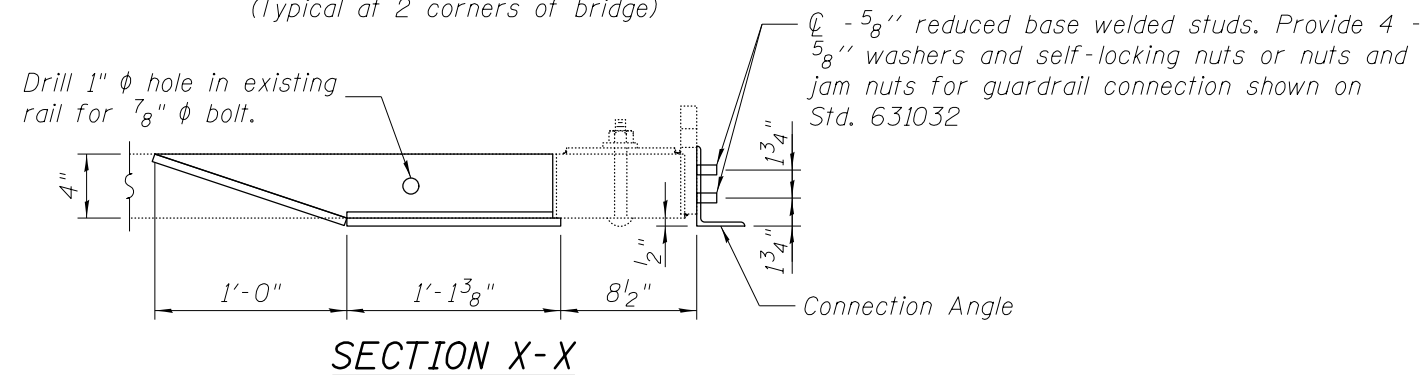

SECTION X-X

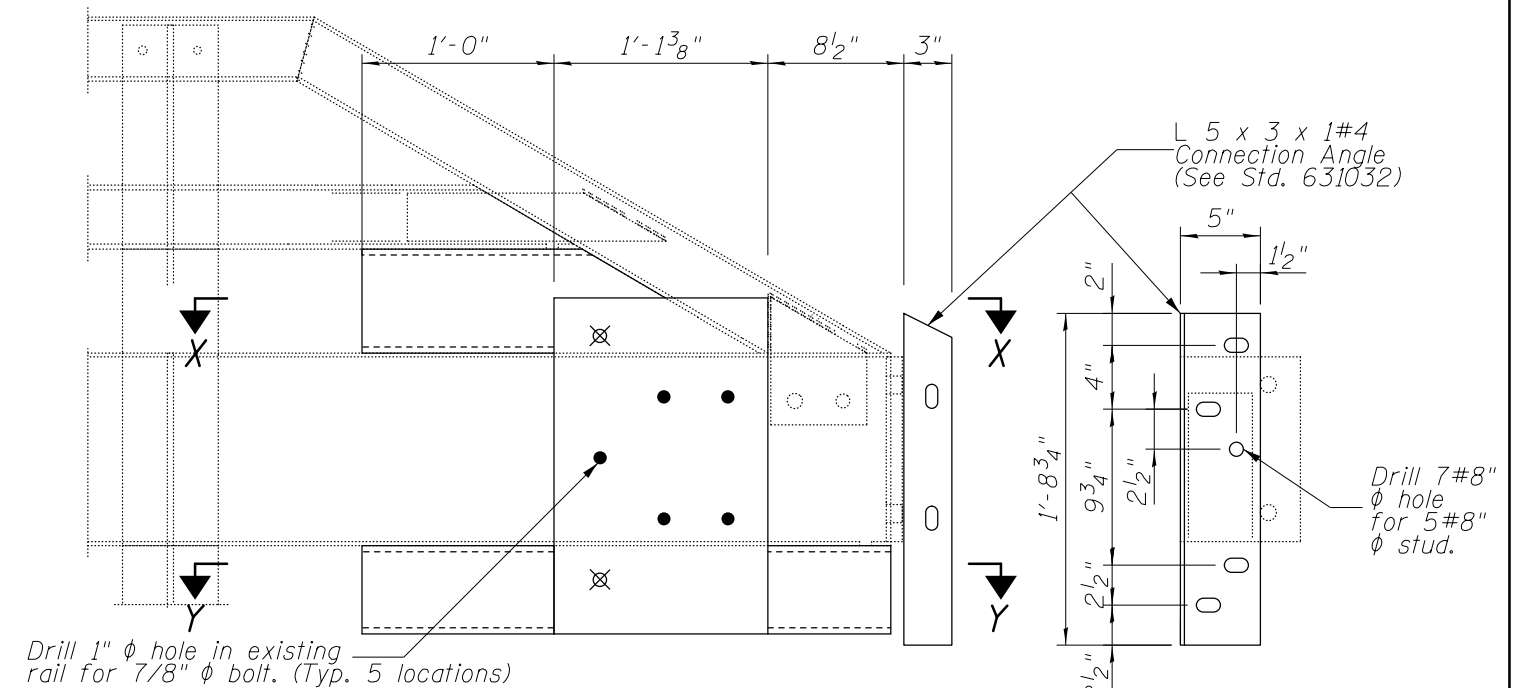

END OF RAIL DETAILS
(Typical at 2 corners of bridge)

END VIEW

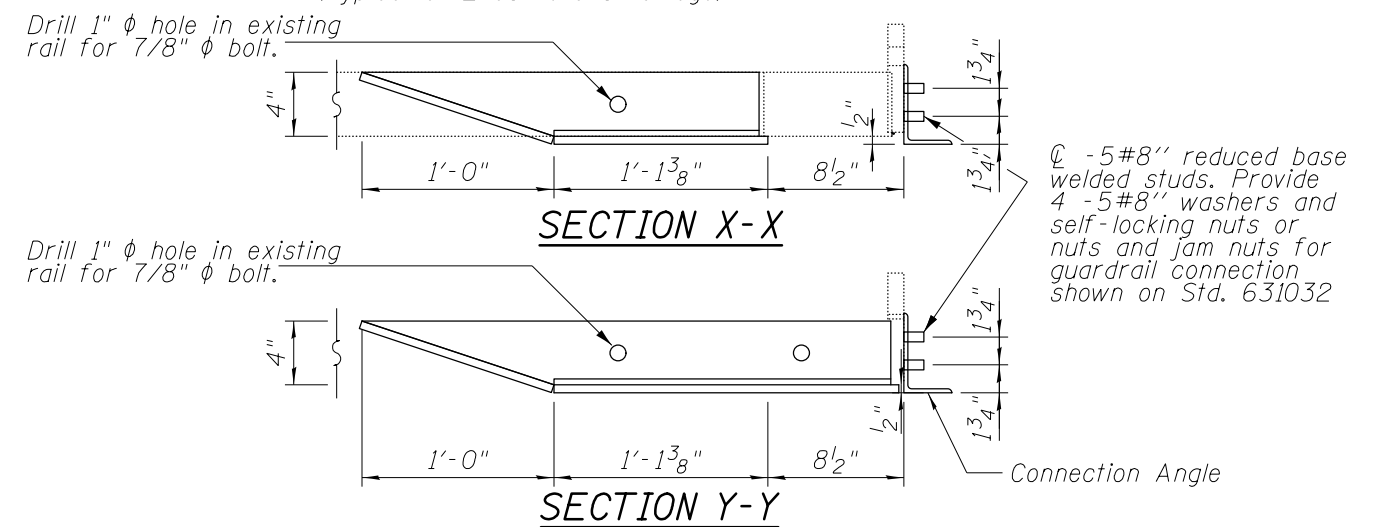

SECTION X-X

SECTION Y-Y

MODEL: \\MODEL\NAME
 FILE: \\NAME: \\path\to\file.doc
 PROJECT: \\PROJECT\NAME
 OFFICE: \\OFFICE\NAME
 DESIGNED: \\DESIGNED\NAME
 DRAWN: \\DRAWN\NAME
 CHECKED: \\CHECKED\NAME
 DATE: \\DATE\MM/DD/YYYY



USER NAME = PiersonTJ	DESIGNED -	REVISED -
	DRAWN -	REVISED -
PLOT SCALE = 2,000' / in.	CHECKED -	REVISED -
PLOT DATE = 3/22/2019	DATE -	REVISED -

**STATE OF ILLINOIS
DEPARTMENT OF TRANSPORTATION**

**TRAFFIC BARRIER TERMINAL TYPE 6A
(MODIFIED) MOUNTING DETAILS**

SCALE: N.T.S. SHEET 1 OF 1 SHEETS STA. TO STA.

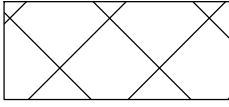
F.A.P. RTE.	SECTION	COUNTY	TOTAL SHEETS	SHEET NO.
836	**	-	214	75
CONTRACT NO. 70D56				

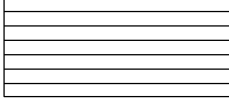
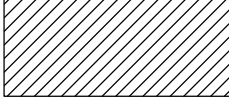
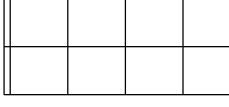
-  (A) - EARTH EXCAVATION
FOR AGGREGATE REMOVAL
FOR PROPOSED HMA SHOULDER
-  (B) - VEGETATION REMOVAL
-  (C) - EARTHWORK FILL
(COMPROMISED OF 60/40 MIX)
-  (D) - EARTHWORK CUT
(EARTH EXCAVATION)
-  (E) - *4" TILLED

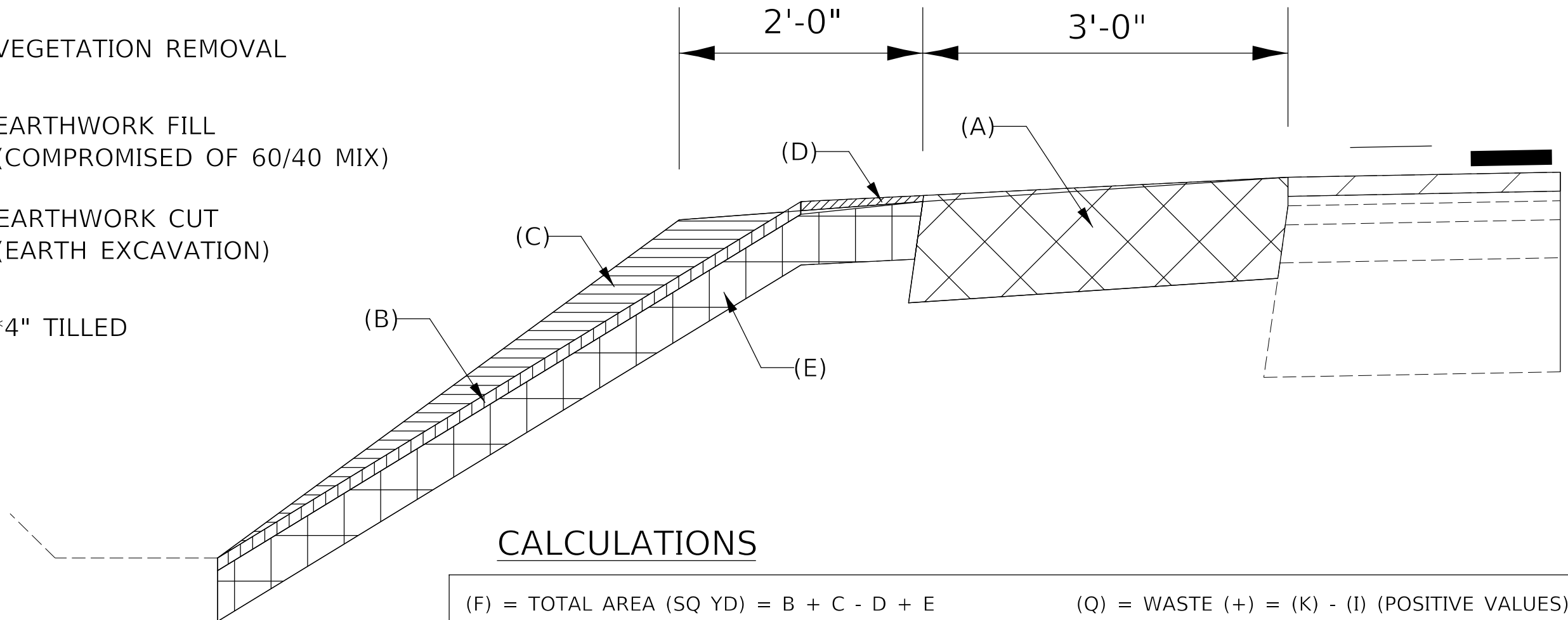

CALCULATIONS

<p>(F) = TOTAL AREA (SQ YD) = B + C - D + E</p> <p>(G) = TOTAL FILL (CU YD) = $\frac{(F_1 + (F_2) \times \text{LENGTH})}{2}$</p> <p>(H) = AGG. NEEDED IN FILL = (G) * 40%</p> <p>(I) = EARTH NEEDED IN FILL = (G) * 60%</p> <p>(J) = EXISTING AGG. AVAILABLE = $\frac{(A_1 + (A_2) \times \text{LENGTH})}{2}$</p> <p>(K) = EXISTING TILLED EARTH = $\frac{(E_1 + (E_2) \times \text{LENGTH})}{2}$</p> <p>(O) = WASTE (+) = (J) - (H) (POSITIVE VALUES) AGG</p> <p>(P) = NEED (-) = (J) - (H) (NEGATIVE VALUES) AGG</p>	<p>(Q) = WASTE (+) = (K) - (I) (POSITIVE VALUES) EARTH</p> <p>(R) = NEED (-) = (K) - (I) (NEGATIVE VALUES) EARTH</p> <p>(L) = EARTH = (J) + (Q) EXCAVATION</p> <p>(M) = EARTH = (R) EMBANKMENT</p> <p>(N) = AGGREGATE = (P) EMBANKMENT</p>
---	--

*PORTIONS OF VOLUME MAY BE INCLUDED IN EARTH EXCAVATION IF TILLED VOLUME IS GREATER THAN THE EARTH NEEDED IN FILL VOLUME

MODEL: \\MODEL\MAME... FILE: \\MAME... \Projects\0570D56\CADD\Drawings\DOT Office\Detail\ 5\Project\0570D56\CADD\Drawings\DOT Office\Detail\ 5\Project\0570D56-e-h-typical_Cross_Section.dgn

USER NAME = PiersonTJ	DESIGNED -	REVISED -
	DRAWN -	REVISED -
PLOT SCALE = 3,0000' / in.	CHECKED -	REVISED -
PLOT DATE = 3/22/2019	DATE -	REVISED -

**STATE OF ILLINOIS
DEPARTMENT OF TRANSPORTATION**

**EARTHWORK CALCULATIONS
DETAIL**

SCALE: N.T.S. SHEET 1 OF 1 SHEETS STA. TO STA.

F.A.P. RTE.	SECTION	COUNTY	TOTAL SHEETS	SHEET NO.
836	**	-	214	76
			CONTRACT NO. 70D56	

POROUS GRANULAR EMBANKMENT

POROUS GRANULAR EMBANKMENT SHALL EXTEND 2 FT. BEYOND THE AGGREGATE SHOULDER.

THE WORK SHOWN IN THE DETAIL SHALL BE PERFORMED IN ACCORDANCE WITH THE APPLICABLE PORTIONS OF SECTION 207 AND SECTION 540 OF THE STANDARD SPECIFICATIONS.

THE COARSE AGGREGATE QUALITY SHALL BE CLASS D OR BETTER AND THE GRADATION SHALL BE CA-6 OR CA-10.

POROUS GRANULAR EMBANKMENT WILL BE MEASURED FOR PAYMENT IN CUBIC YARDS, IN PLACE AS SHOWN. IF THE CONTRACTOR CHOOSES TO EXCAVATE BEYOND THE LIMITS SHOWN, ADDITIONAL QUANTITIES OF POROUS GRANULAR EMBANKMENT WILL BE AT HIS/HER OWN EXPENSE.

THE AREA TO BE EXCAVATED FOR THE PROPOSED BOX CULVERT AND END SECTIONS SHALL NOT BE MEASURED FOR PAYMENT. COST INCLUDED WITH PRECAST CONCRETE BOX CULVERTS.

*** IN LIEU OF POROUS GRANULAR EMBANKMENT, THE CONTRACTOR MAY, AT NO ADDITIONAL COST TO THE DEPARTMENT, BACKFILL THE TRENCH FROM THE MEMBRANE WATERPROOFING TO BOTTOM OF PAVEMENT, EXCEPT THE OUTER 3 FT, WITH CONTROLLED LOW-STRENGTH MATERIAL ACCORDING TO SECTION 593.

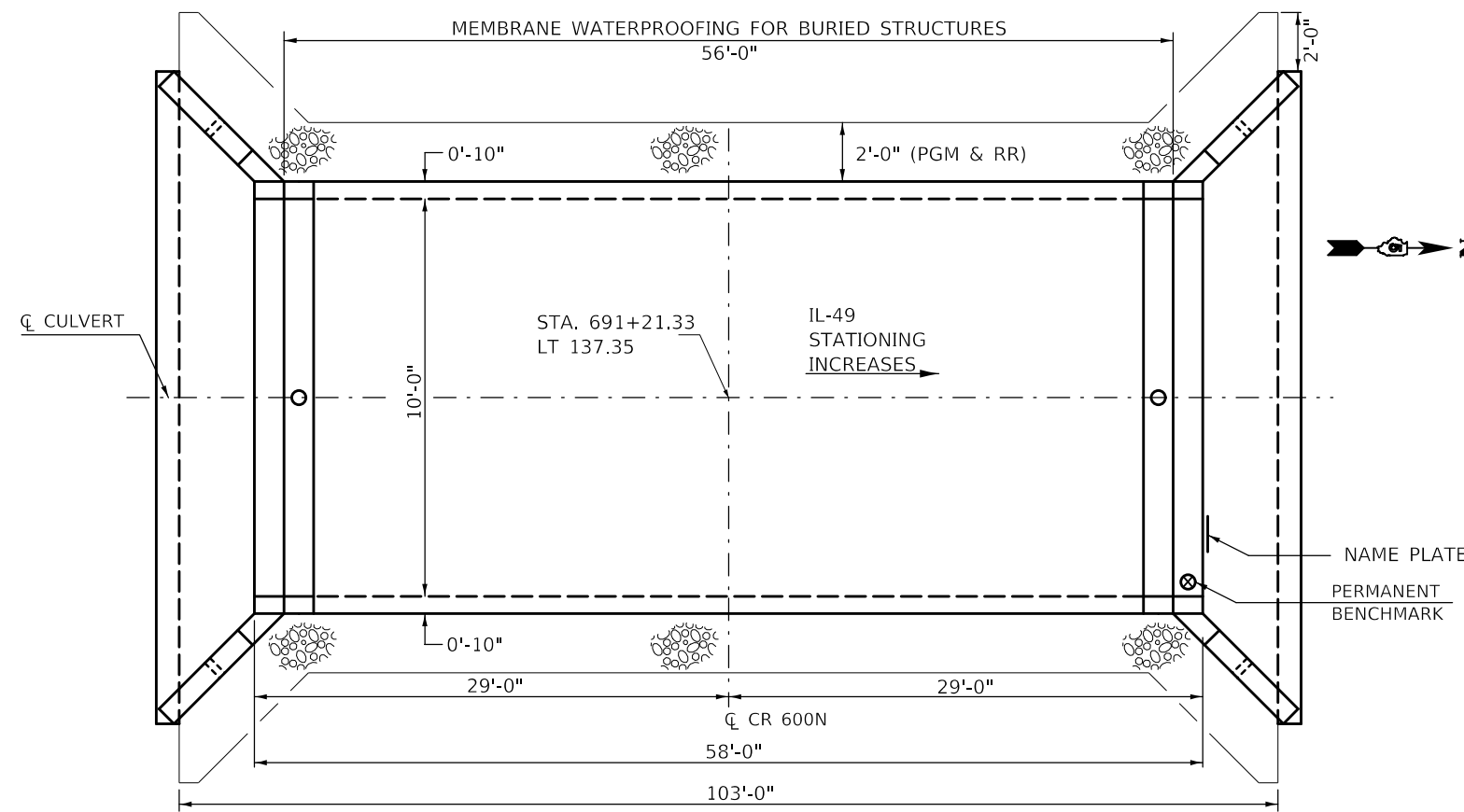

MEMBRANE WATERPROOFING FOR BURIED STRUCTURES

SEE SPECIAL PROVISIONS

PLAN

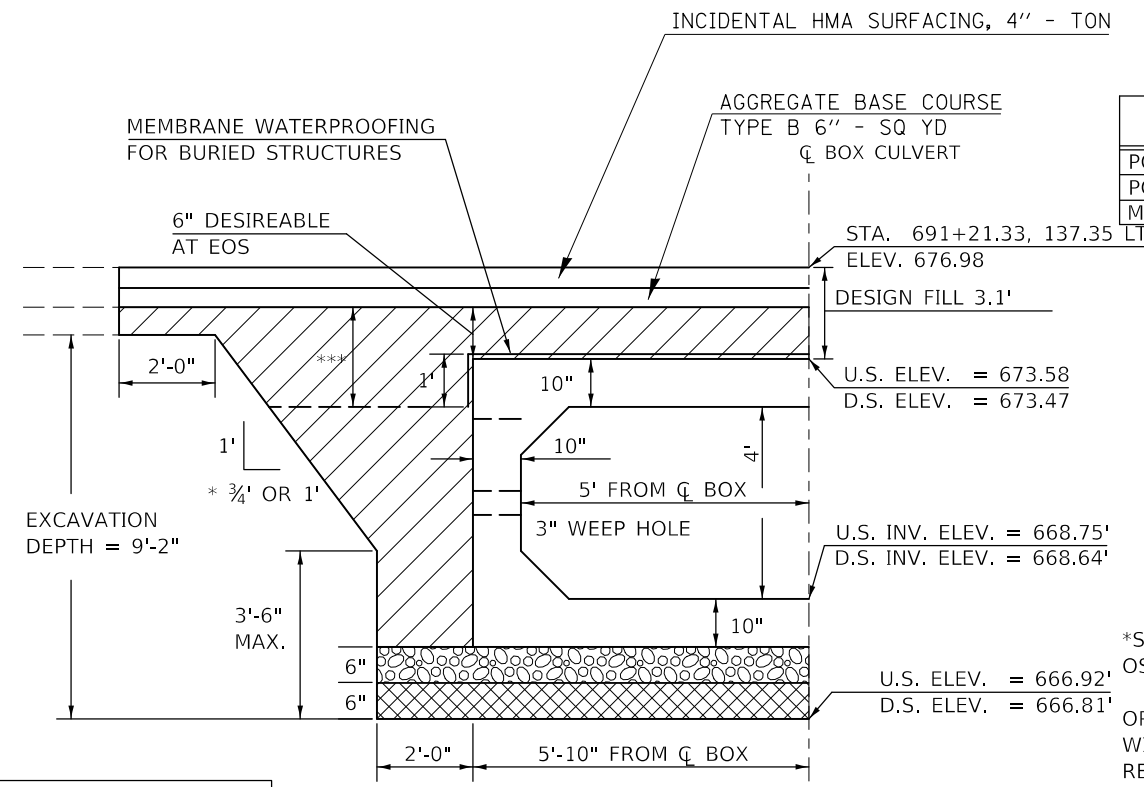

BILL OF MATERIAL

Item	Unit	Total
POROUS GRANULAR EMBANKMENT, BACKFILL	CU YD	285.8
POROUS GRANULAR EMBANKMENT, EXTRA 6" UNDERCUT	CU YD	29.8
MEMBRANE WATERPROOFING FOR BURIED STRUCTURES	SQ YD	0

EXCAVATION DEPTHS	* SLOPES
5'-0" < EXCAVATION DEPTH <= 8'-0"	3/4' : 1'
8'-0" < EXCAVATION DEPTH <= 12'-0"	1' : 1'
12'-0" < EXCAVATION DEPTH <= 20'-0"	1' : 1'

MUST BE SLOPED FROM EXCAVATION BOTTOM OR SPECIAL DESIGN BY S.E. SEE ARTICLE 522.07 FOR TEMPORARY SOIL RETENTION SYSTEM

*SLOPED EXCAVATION IN TYPE A SOIL SHOWN PER APPENDIX B OF OSHA CFR LABOR 29 PART 1926 SUBPART P - EXCAVATIONS.

OPTIONAL CONFIGURATIONS MAY BE CONSTRUCTED IN ACCORDANCE WITH OSHA REQUIREMENTS CONTAINED IN THE CODE OF FEDERAL REGULATIONS LABOR 29 PART 1926 SUBPART P - EXCAVATIONS.

SEE ARTICLE 107.28 FOR CONTRACTOR SAFETY RESPONSIBILITY.

Note: All dimensions are in INCHES (millimeters) unless otherwise shown.

LEGEND	
	POROUS GRANULAR EMBANKMENT
	POROUS GRANULAR MATERIAL (CA-7) (INCLUDED WITH PRECAST BOX CULVERT)
	POROUS GRANULAR MATERIAL (CA-7) (ADDITIONAL UNDERCUT MATERIAL, PAID SEPERATE)

HALF SECTION SHOWN
SEE EXCAVATION DEPTHS TABLE

MODEL: 4\MODEL\MATF... FILE: 4\matf... PROJECT: 0570056\CADD\DATA\Design\0570056-ht-Detail\Porous Granular Embankment.dgn

USER NAME = PiersonTJ	DESIGNED -	REVISED - TJB
	DRAWN -	REVISED - TJB
PLOT SCALE = 40,0000 ' / in.	CHECKED -	REVISED -
PLOT DATE = 4/3/2019	DATE -	REVISED - 08/29/2017

STATE OF ILLINOIS
DEPARTMENT OF TRANSPORTATION

POROUS GRANULAR EMBANKMENT
S.N. 010- 8176; CULVERT NO. 1

SCALE: N.T.S. SHEET 1 OF 1 SHEETS STA. TO STA.

DISTRICT 5 DETAIL NO. 20700220				
F.A.P. RTE.	SECTION	COUNTY	TOTAL SHEETS	SHEET NO.
836	**	-	214	77
			CONTRACT NO. 70D56	

POROUS GRANULAR EMBANKMENT

POROUS GRANULAR EMBANKMENT SHALL EXTEND 2 FT. BEYOND THE AGGREGATE SHOULDER.

THE WORK SHOWN IN THE DETAIL SHALL BE PERFORMED IN ACCORDANCE WITH THE APPLICABLE PORTIONS OF SECTION 207 AND SECTION 540 OF THE STANDARD SPECIFICATIONS.

THE COARSE AGGREGATE QUALITY SHALL BE CLASS D OR BETTER AND THE GRADTION SHALL BE CA-6 OR CA-10.

POROUS GRANULAR EMBANKMENT WILL BE MEASURED FOR PAYMENT IN CUBIC YARDS, IN PLACE AS SHOWN. IF THE CONTRACTOR CHOOSES TO EXCAVATE BEYOND THE LIMITS SHOWN, ADDITIONAL QUANTITIES OF POROUS GRANULAR EMBANKMENT WILL BE AT HIS/HER OWN EXPENSE.

THE AREA TO BE EXCAVATED FOR THE PROPOSED BOX CULVERT AND END SECTIONS SHALL NOT BE MEASURED FOR PAYMENT. COST INCLUDED WITH PRECAST CONCRETE BOX CULVERTS.

*** IN LIEU OF POROUS GRANULAR EMBANKMENT, THE CONTRACTOR MAY, AT NO ADDITIONAL COST TO THE DEPARTMENT, BACKFILL THE TRENCH FROM THE MEMBRANE WATERPROOFING TO BOTTOM OF PAVEMENT, EXCEPT THE OUTER 3 FT, WITH CONTROLLED LOW-STRENGTH MATERIAL ACCORDING TO SECTION 593.

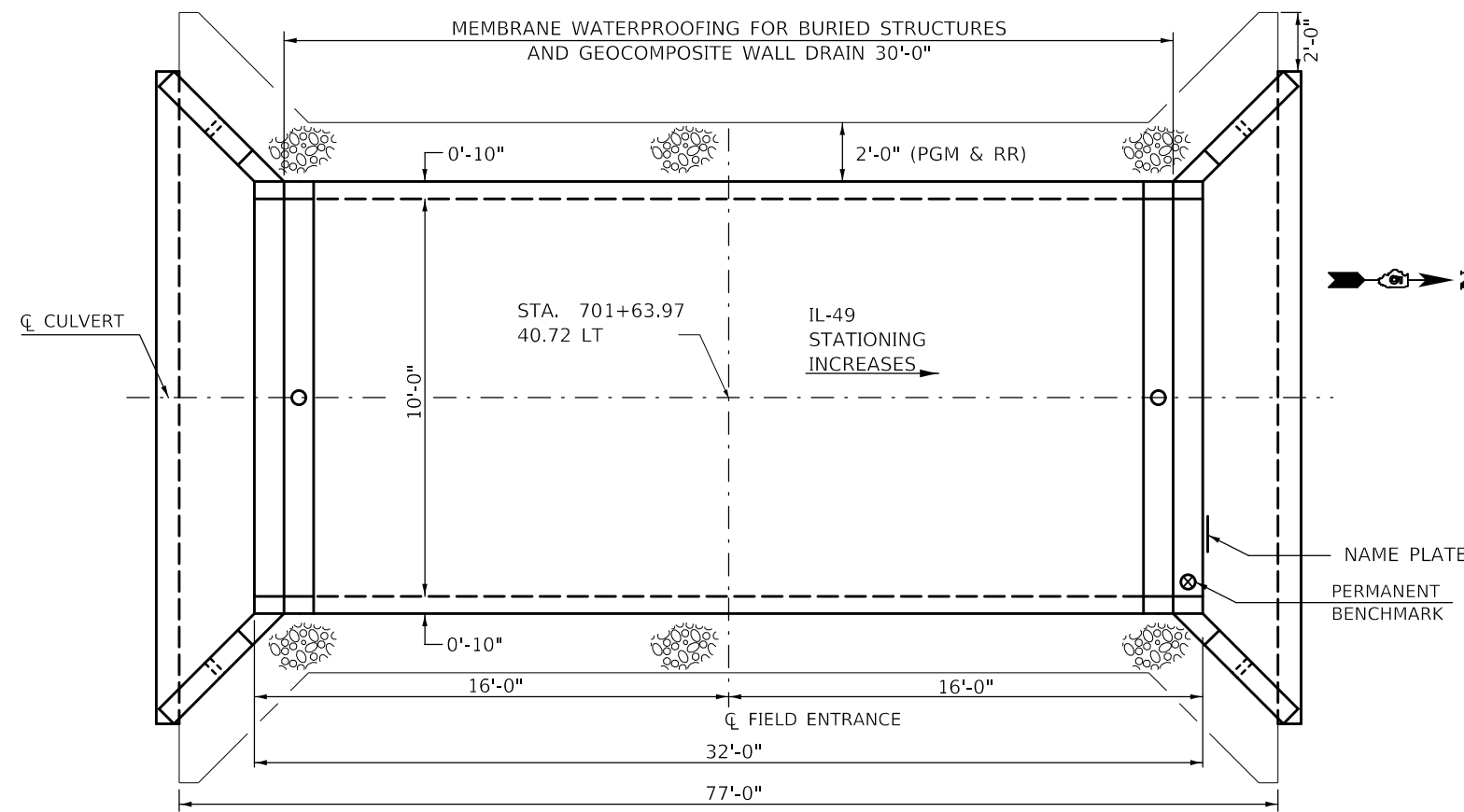

MEMBRANE WATERPROOFING FOR BURIED STRUCTURES

SEE SPECIAL PROVISIONS

PLAN

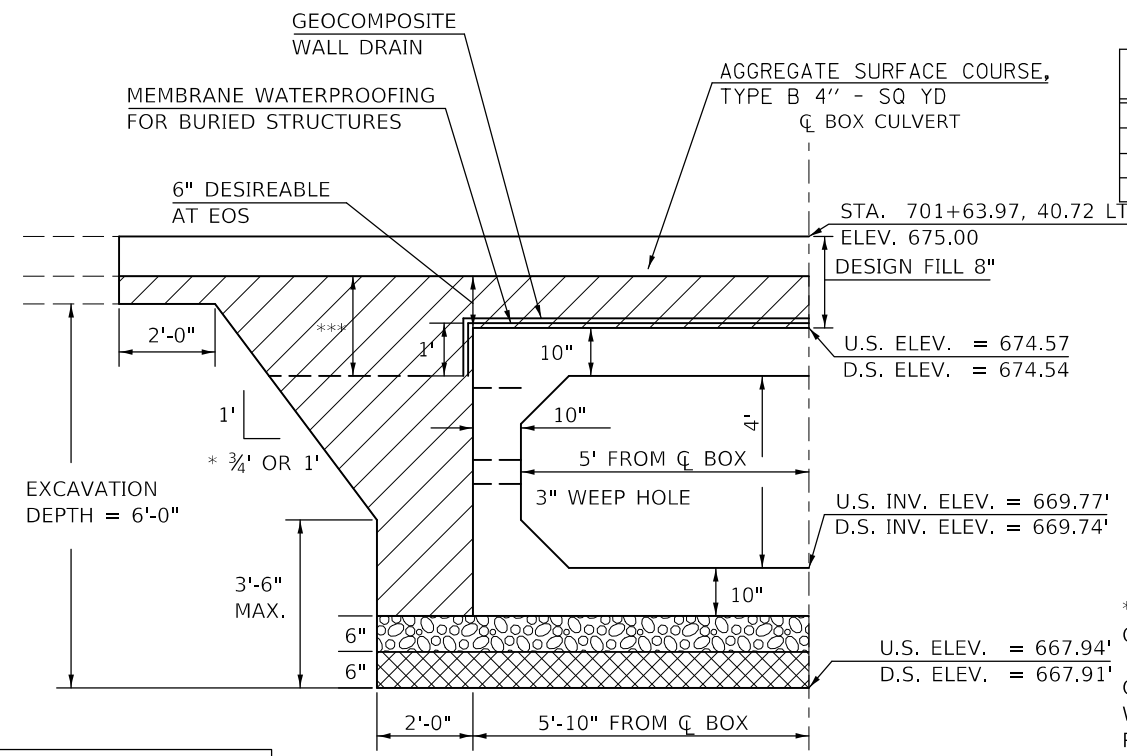

BILL OF MATERIAL

Item	Unit	Total
POROUS GRANULAR EMBANKMENT, BACKFILL	CU YD	105.2
POROUS GRANULAR EMBANKMENT, EXTRA 6" UNDERCUT	CU YD	22.2
MEMBRANE WATERPROOFING FOR BURIED STRUCTURES	SQ YD	40
GEOCOMPOSITE WALL DRAIN	SQ YD	40

EXCAVATION DEPTHS	* SLOPES
5'-0" < EXCAVATION DEPTH <= 8'-0"	3/4' : 1'
8'-0" < EXCAVATION DEPTH <= 12'-0"	1' : 1'
12'-0" < EXCAVATION DEPTH <= 20'-0"	1' : 1'

MUST BE SLOPED FROM EXCAVATION BOTTOM OR SPECIAL DESIGN BY S.E. SEE ARTICLE 522.07 FOR TEMPORARY SOIL RETENTION SYSTEM

*SLOPED EXCAVATION IN TYPE A SOIL SHOWN PER APPENDIX B OF OSHA CFR LABOR 29 PART 1926 SUBPART P - EXCAVATIONS.

OPTIONAL CONFIGURATIONS MAY BE CONSTRUCTED IN ACCORDANCE WITH OSHA REQUIREMENTS CONTAINED IN THE CODE OF FEDERAL REGULATIONS LABOR 29 PART 1926 SUBPART P - EXCAVATIONS.

SEE ARTICLE 107.28 FOR CONTRACTOR SAFETY RESPONSIBILITY.

Note: All dimensions are in INCHES (millimeters) unless otherwise shown.

LEGEND	
	POROUS GRANULAR EMBANKMENT
	POROUS GRANULAR MATERIAL (CA-7) (INCLUDED WITH PRECAST BOX CULVERT)
	POROUS GRANULAR MATERIAL (CA-7) (ADDITIONAL UNDERCUT MATERIAL, PAID SEPERATE)

HALF SECTION SHOWN
SEE EXCAVATION DEPTHS TABLE

MODEL: 4\MODEL\MAR18... FILE: 4\mar18... \Projects\05700556\CADD\Drawings\05700556-11-Detail\Porous Granular Embankment.dgn

USER NAME = PiersonTJ	DESIGNED -	REVISED - TJB
	DRAWN -	REVISED - TJB
PLOT SCALE = 40.0000 ' / in.	CHECKED -	REVISED -
PLOT DATE = 4/30/2019	DATE -	REVISED - 08/29/2017

STATE OF ILLINOIS
DEPARTMENT OF TRANSPORTATION

POROUS GRANULAR EMBANKMENT
S.N. 010- 8177; CULVERT NO. 2

SCALE: N.T.S. SHEET 1 OF 1 SHEETS STA. TO STA.

DISTRICT 5 DETAIL NO. 20700220				
F.A.P. RTE.	SECTION	COUNTY	TOTAL SHEETS	SHEET NO.
836	**	-	214	78
			CONTRACT NO. 70D56	

PROJECTS WITHOUT RECONSTRUCTION ("3R" WITHOUT RECONSTRUCTION, 3P, SMART AND CM)

S.M.A.R.T. IMPROVEMENTS (POLICY RESURFACING; BDE 53-4.03; 1½")

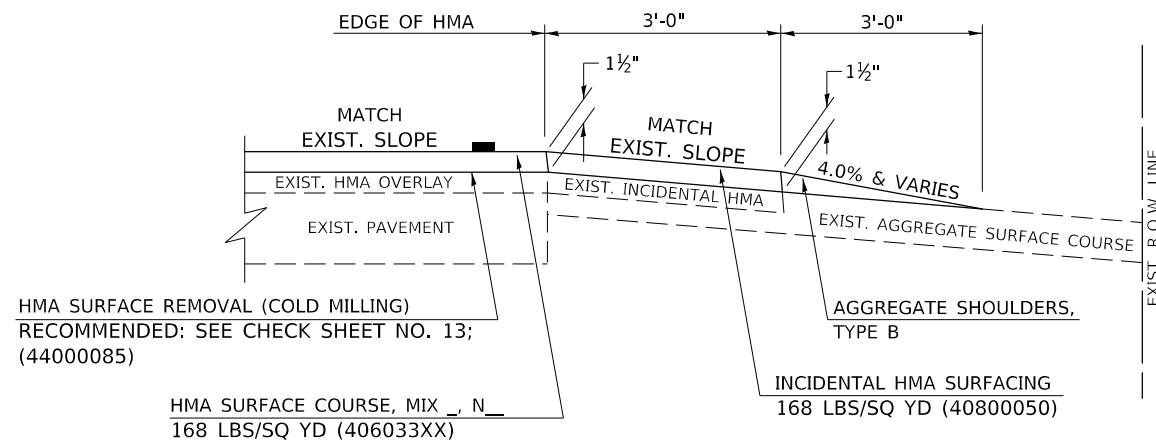

PROJECTS WITH RECONSTRUCTION ("3R" IMPROVEMENTS AND SMART/3P "SPOT" LOCATIONS)

ADJACENT TO PROPOSED HMA SHOULDERS (AGGREGATE OR EARTH ENTRANCE)

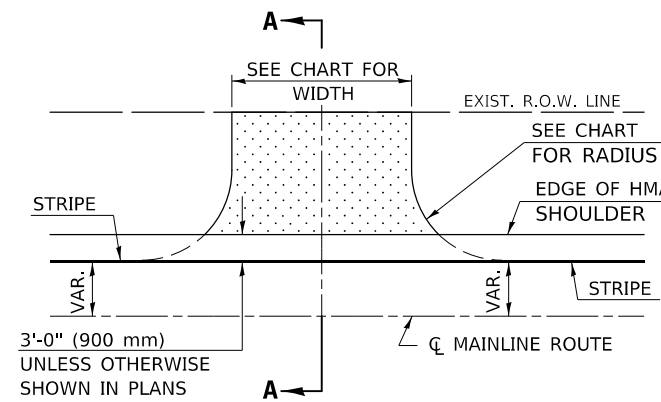

TYPICAL APPLICATION

EXISTING AGGREGATE OR EARTH ENTRANCE

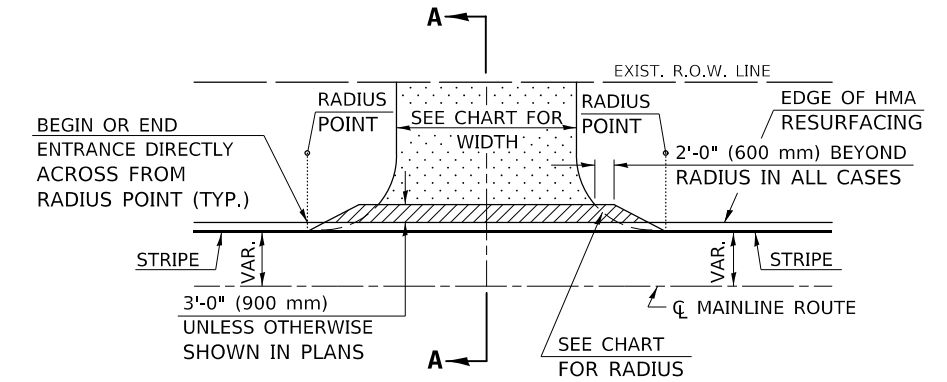

TYPICAL APPLICATION

"3P" OR "3R" IMPROVEMENTS (POLICY RESURFACING; BDE 53-4.02; 2¼" OR 2½" ON BARE CONCRETE)

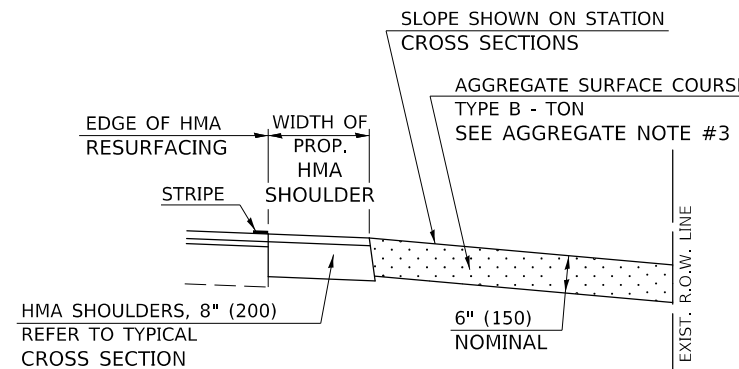
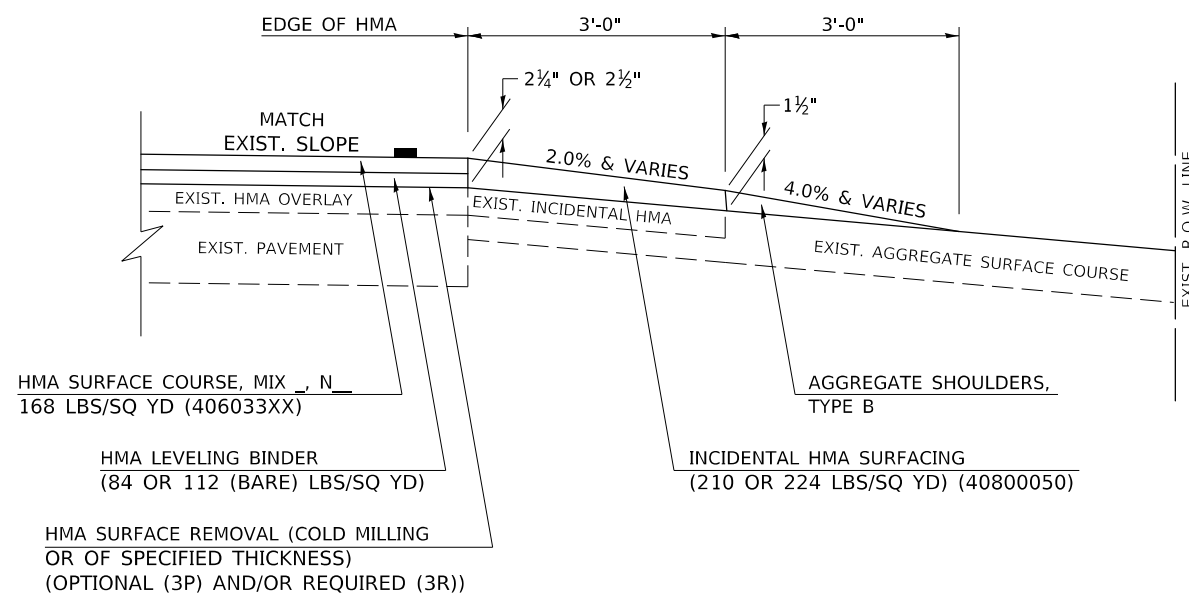

SECTION A-A

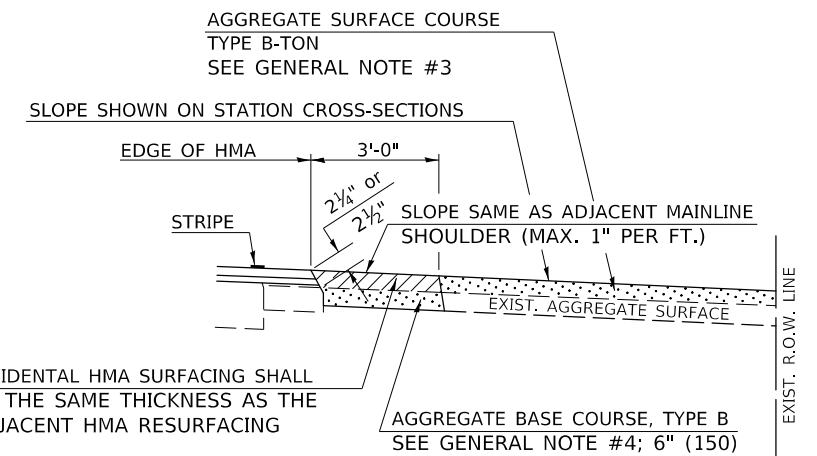

SECTION A-A

Note: All dimensions are in INCHES (millimeters) unless otherwise shown.

DISTRICT 5 DETAIL NO. 4080050A

STATE OF ILLINOIS
DEPARTMENT OF TRANSPORTATION

FIELD ENTRANCES (NONCOMMERCIAL RURAL)

F.A.P. RTE.	SECTION	COUNTY	TOTAL SHEETS	SHEET NO.
836	**	-	214	79
CONTRACT NO. 70D56				

SCALE: SHEET 1 OF 2 SHEETS STA. TO STA.

**118RS-3,119RS-4,D5 HSIP 2019-1

*CHAMPAIGN & VERMILION

GENERAL NOTES

1. THE EXISTING SURFACE SHALL BE PREPARED IN ACCORDANCE WITH SECTION 408 OF THE STANDARD SPECIFICATIONS.
2. ANY NECESSARY WORK BEHIND THE HMA SHOULDER OR THE INCIDENTAL HMA SURFACING SHALL BE AS SHOWN IN THE PLANS AND/OR AS DIRECTED BY THE ENGINEER.
3. EARTH EXCAVATION REQUIRED FOR THE CONSTRUCTION OF THE AGGREGATE SURFACE COURSE SHALL BE INCLUDED IN THE COST OF AGGREGATE SURFACE COURSE.
4. AGGREGATE BASE COURSE, TYPE B, 6" (150 mm) MIN. SHALL BE USED WHERE IN THE OPINION OF THE ENGINEER THERE IS NOT SUFFICIENT BASE MATERIAL FOR THE PROPOSED ENTRANCES. THIS MATERIAL SHALL GENERALLY BE USED TO WIDEN ANY EXISTING RETURN OR TO CONSTRUCT NEW ENTRANCES WHERE NONE NOW EXISTS.
5. THE AGGREGATE BASE COURSE SHALL BE CONSTRUCTED 12" (300 mm) WIDER THAN THE SURFACE DIMENSIONS AS SHOWN ABOVE.
6. EXISTING FIELD ENTRANCES OF AGGREGATE OR EARTH WITH NO HMA APRON SHALL NOT RECEIVE A NEW HMA APRON WITHOUT PROPER APPROVAL THROUGH THE BUREAU OF OPERATIONS "POLICY ON PERMITS FOR ACCESS DRIVEWAYS TO STATE HIGHWAYS".
7. TO ASSURE APPROPRIATE ACCESS POLICIES ARE FOLLOWED ALL NEW ACCESS SHALL BE APPLIED FOR THROUGH THE BUREAU OF OPERATIONS PERMIT APPLICATION PROCESS. PLAN PREPARATION MEMORANDUMS 40-09 ALONG WITH DISTRICT PROJECT IMPLEMENTATION MEMORANDUM 104/01 DISCUSS THIS PROCEDURE.

RURAL ENTRANCE DESIGN STANDARDS (PPM 40-09)															
DESIGN ELEMENT	NEW CONSTRUCTION & 3R with CONSTRUCTION						3R w/out RECONSTRUCTION, 3P, SMART & CM								
	NONCOMMERCIAL			FIELD W/FARM IMPLEMENTS			COMMERCIAL			NONCOMMERCIAL			COMMERCIAL		
	PRIVATE & FIELD			FIELD W/FARM IMPLEMENTS			COMMERCIAL			PRIVATE & FIELD			COMMERCIAL		
	min.	des.	max.	min.	max.	min.	des.	max.	min.	des.	max.	min.	des.	max.	
SURFACE WIDTH (FT)	12	16	24	24	30	1 LANE, 1 WAY			1 LANE, 1 WAY						
						14	16	24							
						2 LANE, 2 WAY			2 LANE, 2 WAY						
						24	30	35	resurface existing configuration; existing aggregate or earth entrances shall have the continuation of aggregate shoulders placed behind them						
RADIUS (FT)	15	25	40	30		20	30	50							
SHOULDER WIDTH (FT)	2	2		2		1	3								
SHOULDER SLOPE (%)	2	4	6	4		2	4	6							
ENTRANCE GRADE (%)	0	2 to 5	10 or 12	2 to 5	10 or 12	0	2 to 5	8 or 10							
SIDE SLOPE (FT)	1:4	1:6	1:10	1:4	1:6	1:4	1:6	1:10							
SURFACE TYPE															
INCIDENTAL HMA SURFACING (INCH)		2		2		3 or 4			taper from hma resurfacing thickness (2 1/2", 2 1/4" or 1 1/2") to 1 1/2" to minimize aggregate shoulder						
AGGREGATE SURFACE COURSE, TYPE B (INCH)		6		6		8			if applicable, use items: Preparation of Base & Aggregate Base Repair; see PPM 30-02						
PCC DRIVEWAY PAVEMENT (INCH)		6						6 or 8							

Note: All dimensions are in INCHES (millimeters) unless otherwise shown.

MODEL: \\MODEL\MHFE
FILE NAME: P:\p118rs-3,119rs-4,05 HSIP\DOT Documents\DOT Office\Detail\1 - District 5\Detail\05 Detail\05 Detail.dgn

DISTRICT 5 DETAIL NO. 4080050A

USER NAME = PiersonTJ	DESIGNED -	REVISED - 12/06 TJB
	DRAWN -	REVISED - 09/07 KAG
PLOT SCALE = 40.0000 ' / in.	CHECKED -	REVISED - 04/08 KJT
PLOT DATE = 3/22/2019	DATE -	REVISED - 3/16/17 SWN

**STATE OF ILLINOIS
DEPARTMENT OF TRANSPORTATION**

FIELD ENTRANCES (NONCOMMERCIAL RURAL)

F.A.P. RTE.	SECTION	COUNTY	TOTAL SHEETS	SHEET NO.
836	**	-	214	80
			CONTRACT NO. 70D56	

SCALE: SHEET 2 OF 2 SHEETS STA. TO STA.

PROJECTS WITHOUT RECONSTRUCTION

S.M.A.R.T. IMPROVEMENTS (POLICY RESURFACING; BDE 53-4.03; 1½")

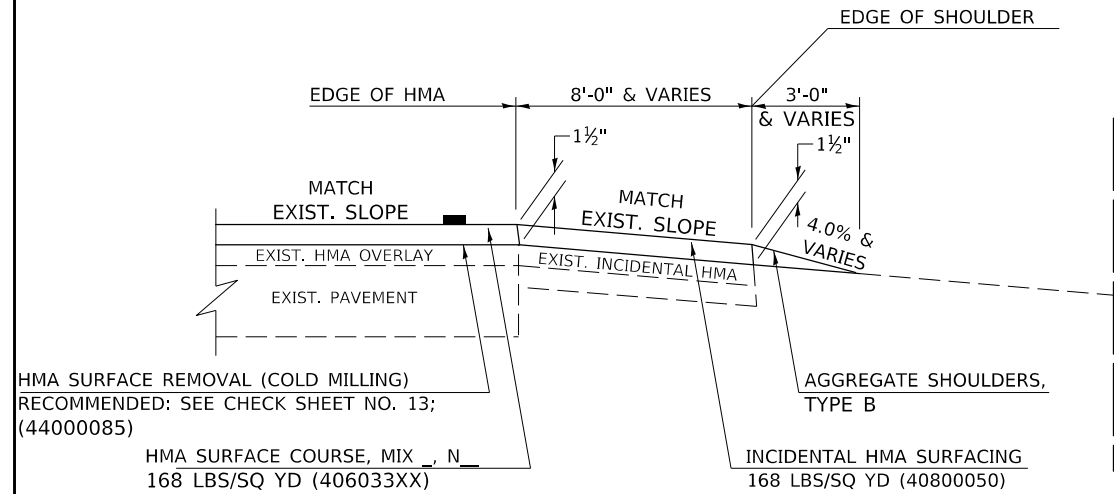

"3P" OR "3R" IMPROVEMENTS (POLICY RESURFACING; BDE 53-4.02; 2¼" OR 2½" ON BARE CONCRETE)

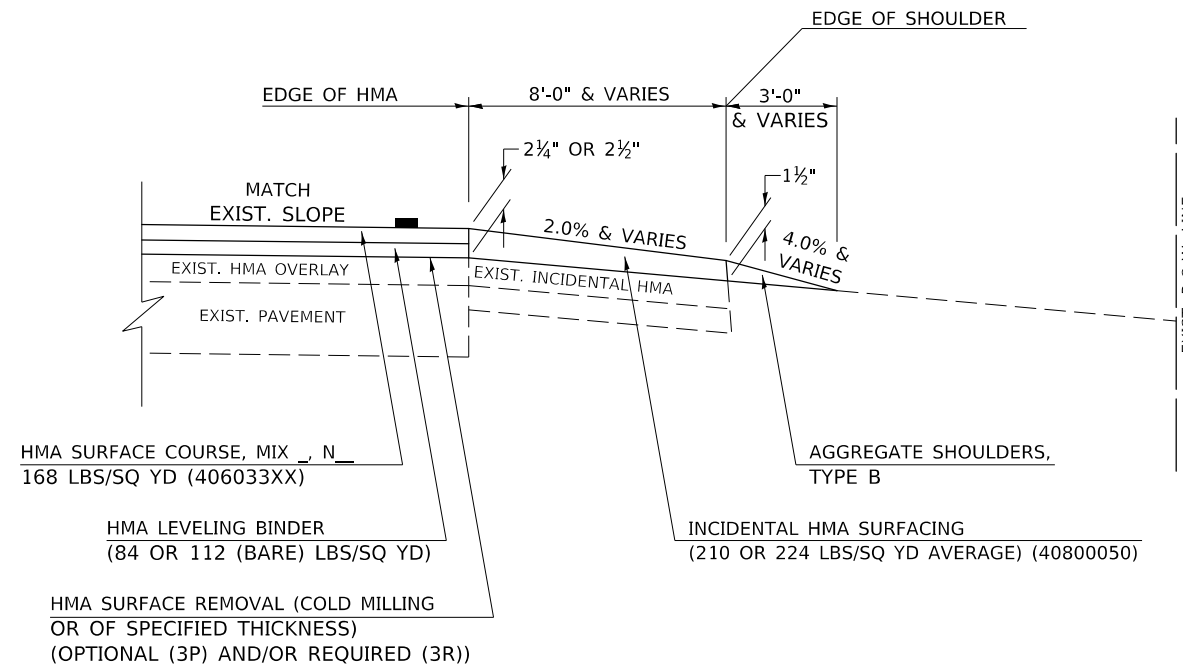

GENERAL NOTES

1. THE EXISTING SURFACE SHALL BE PREPARED IN ACCORDANCE WITH SECTION 408 OF THE STANDARD SPECIFICATIONS.
2. AGGREGATE BASE COURSE, TYPE B, 6" (150) MIN. SHALL BE USED WHERE IN THE OPINION OF THE ENGINEER THERE IS NOT SUFFICIENT BASE MATERIAL FOR THE PROPOSED MAILBOX TURNOUTS. THIS MATERIAL SHALL GENERALLY BE USED TO WIDEN ALL EXISTING MAILBOX TURNOUTS OR TO CONSTRUCT NEW MAILBOX TURNOUTS WHERE NONE NOW EXISTS.
3. ANY NECESSARY WORK BEHIND THE INCIDENTAL HMA SURFACING SHALL BE AS SHOWN IN THE PLANS AND/OR AS DIRECTED BY THE ENGINEER.
4. THE TEMPORARY RELOCATION OF EXISTING MAILBOXES SHALL BE IN ACCORDANCE WITH ARTICLE 107.20 OF THE STANDARD SPECIFICATIONS.
5. WHEN MORE THAN ONE RELOCATED MAILBOX IS INCLUDED IN A PARTICULAR LOCATION THE TWO 10' (3 m) DIMENSIONS AS SHOWN ABOVE SHALL BE FROM THE END MAILBOX.
6. CROSS SLOPE SHALL BE AS SHOWN ON THE STATION CROSS SECTIONS AND/OR AS DIRECTED BY THE ENGINEER.
MINIMUM 4% (1/2"/') DESIRABLE; MAXIMUM 8% (1"/')
7. WHEN MAILBOX TURNOUTS ARE CONSTRUCTED ADJACENT TO FIELD ENTRANCES, THE WIDTH OF THE INCIDENTAL HMA SURFACING CONSTRUCTED FOR THE FIELD ENTRANCE SHALL MATCH THE WIDTH OF THE PROPOSED MAILBOX TURNOUT SURFACING.
8. THE TOTAL SHOULDER WIDTH, 2.4 m (8') MINIMUM, SHALL BE PAVED BETWEEN SIDEROADS ENTRANCES AND/OR MAILBOX TURNOUTS AT LOCATIONS WHERE THE DISTANCE BETWEEN RADIUS OR TAPER CONTROL POINTS IS LESS THAN 15.0 m (50').
9. MAILBOXES SHALL BE MOUNTED SUCH THAT THE FACE OF THE MAILBOX IS 6" (150 mm) TO 12" (300 mm) AND THE POST A MINIMUM OF 24" (600 mm) FROM THE EDGE OF THE TURNOUT SURFACING.

PROJECTS WITH RECONSTRUCTION ("3R" IMPROVEMENTS)

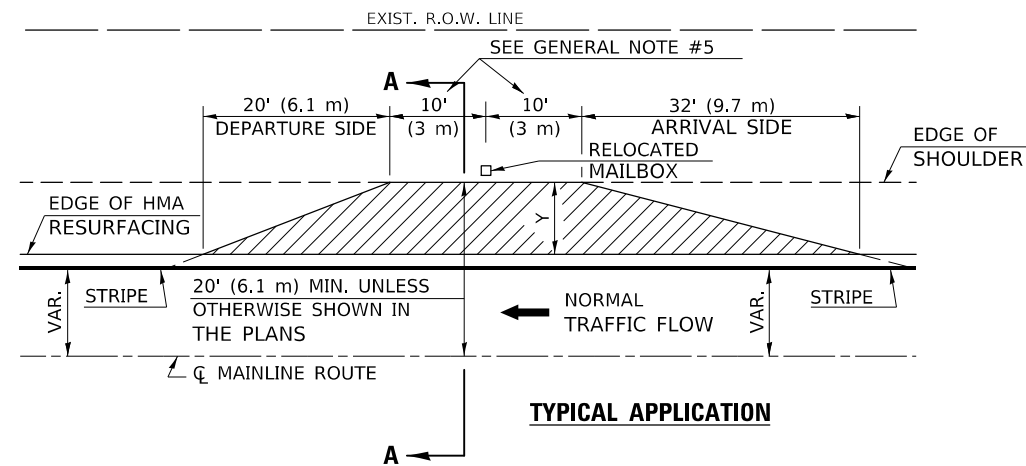

WIDTH OF SHOULDER	4'-0" - 8'-0" (1.2 m - 2.4 m)	10'-0" (3.0 m)
WIDTH OF TURNOUT "Y"	8'-0" (2.4 m)	8'-0" - 10'-0" (2.4 m - 3.0 m)

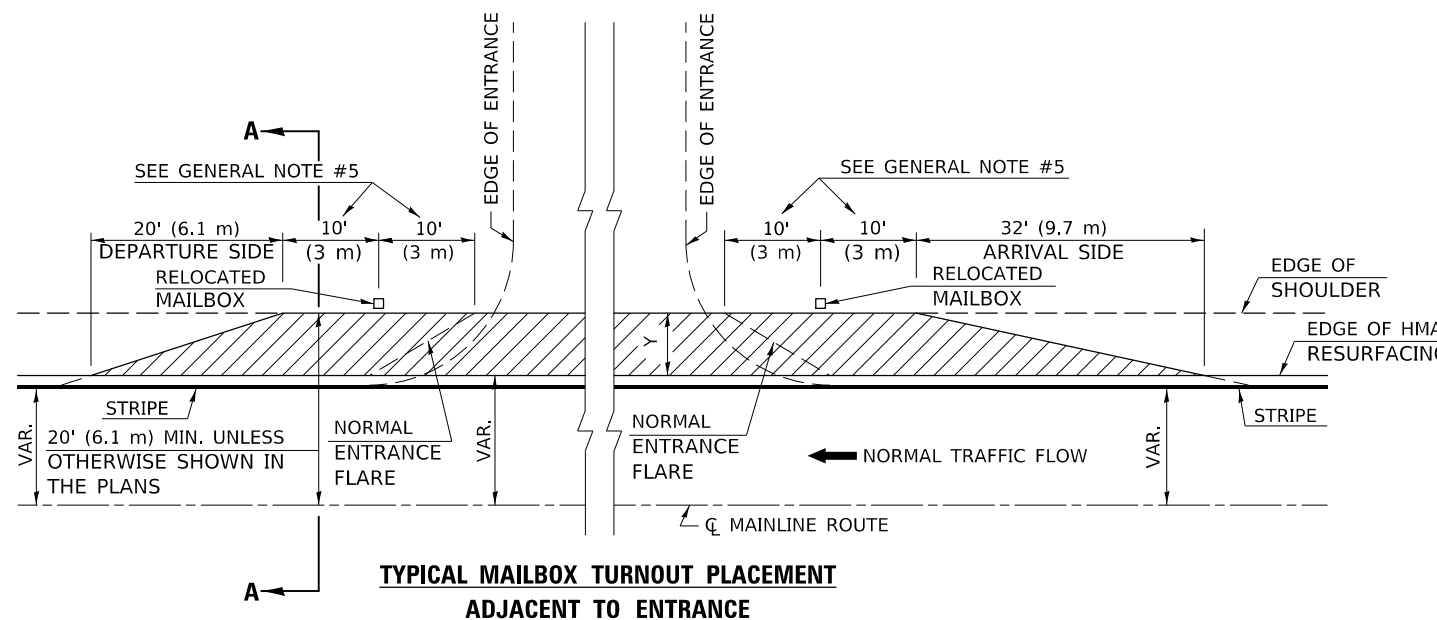
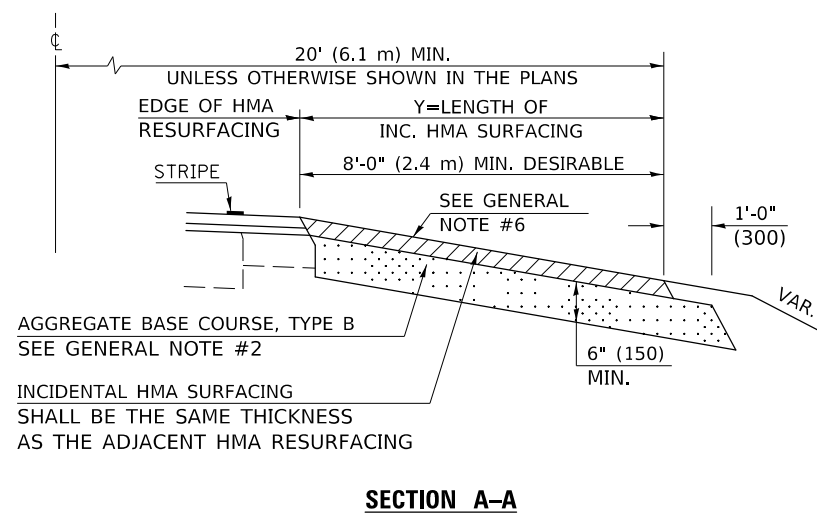

Note: All dimensions are in INCHES (millimeters) unless otherwise shown.

MODEL: \\MODEL\MARTE... FILE NAME: P:\gpc\118RS-3,119RS-4,5 HSIP 2019-1

USER NAME = PiersonTJ	DESIGNED -	REVISOR -	DATE -
DRAWN -	CHECKED -	REVISOR -	DATE -
PLOT SCALE = 40.0000' / in.	DATE -	REVISOR -	DATE -
PLOT DATE = 3/22/2019	DATE -	REVISOR -	DATE -

**STATE OF ILLINOIS
DEPARTMENT OF TRANSPORTATION**

MAILBOX TURNOUT (RURAL)

SCALE: SHEET 1 OF 1 SHEETS STA. TO STA.

DISTRICT 5 DETAIL NO. 40800050B

F.A.P. RTE.	SECTION	COUNTY	TOTAL SHEETS	SHEET NO.
836	**	-	214	81
CONTRACT NO. 70D56				

PROJECTS WITHOUT RECONSTRUCTION

**S.M.A.R.T. IMPROVEMENTS
(POLICY RESURFACING; BDE 53-4.03; 1½")**

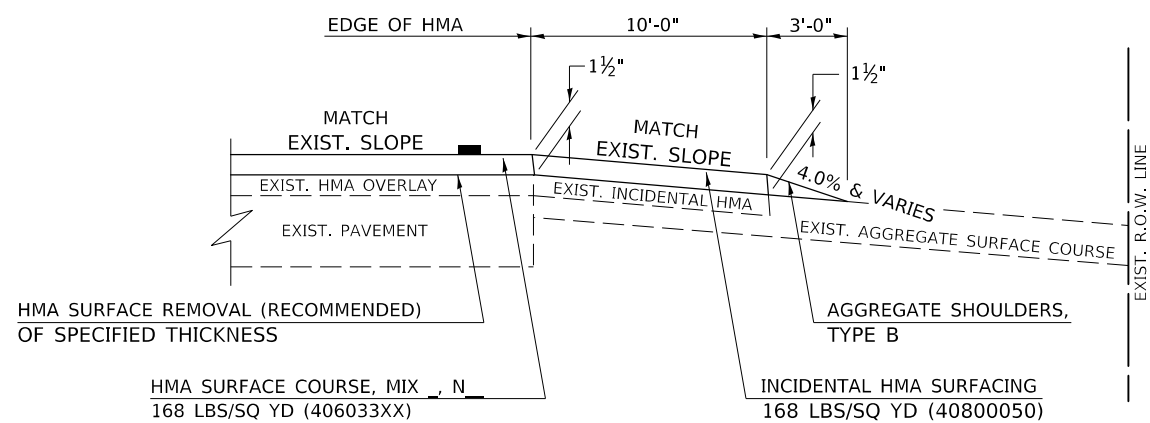

EXISTING AGGREGATE ENTRANCE

**“3P” OR “3R” IMPROVEMENTS
(POLICY RESURFACING; BDE 53-4.02; 2¼” OR 2½” ON BARE CONCRETE)**

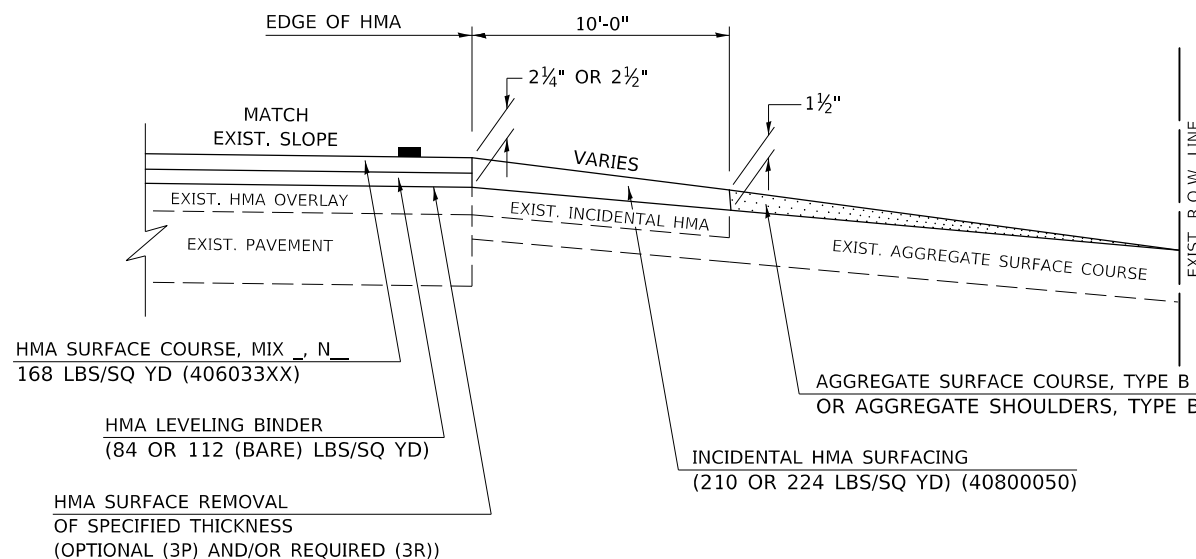

EXISTING AGGREGATE ENTRANCE

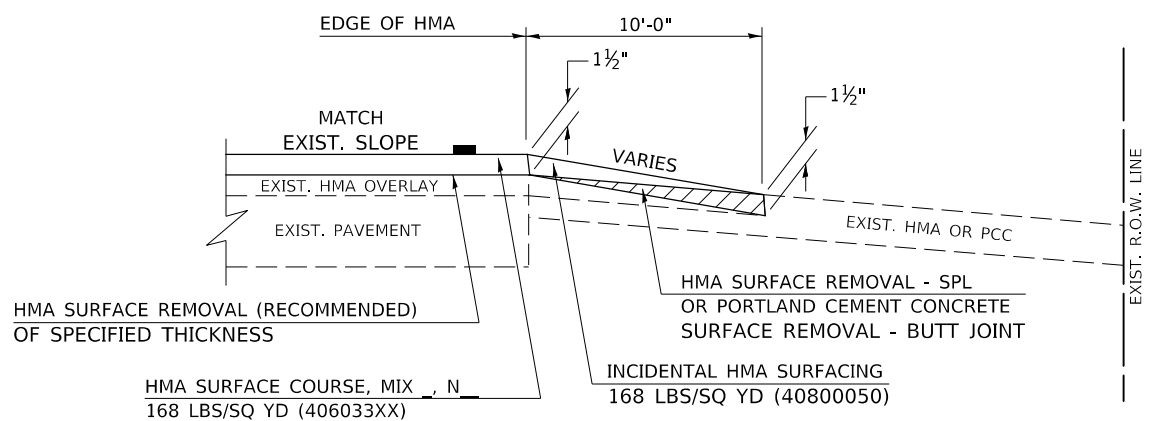

EXISTING HMA OR PCC ENTRANCE

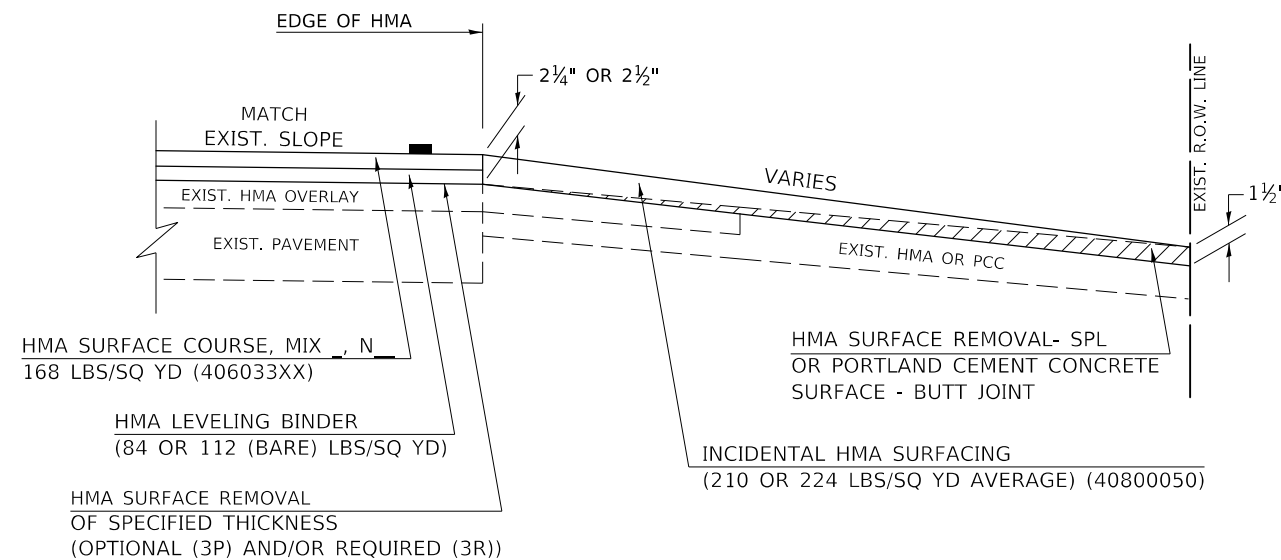

EXISTING HMA OR PCC ENTRANCE

Note: All dimensions are in INCHES (millimeters) unless otherwise shown.

MODEL: \\MODEL\MATHS... FILE NAME: P:\projects\05-70D56\0570D56\0570D56-4-D5-Detail.DWG

USER NAME = PiersonTJ	DESIGNED -	REVISED - 09/07 KAG
PLOT SCALE = 40.0000 "/td> <td>DRAWN -</td> <td>REVISED - 05/08 KJT</td>	DRAWN -	REVISED - 05/08 KJT
PLOT DATE = 3/22/2019	CHECKED -	REVISED - 04/10 KJT
	DATE -	REVISED - 3/6/17 SWN

**STATE OF ILLINOIS
DEPARTMENT OF TRANSPORTATION**

**PRIVATE COMMERCIAL ENTRANCES
(NONCOMMERCIAL AND COMMERCIAL RURAL)**

SCALE: SHEET 1 OF 2 SHEETS STA. TO STA.

DISTRICT 5 DETAIL NO. 40800050C				
F.A.P. RTE.	SECTION	COUNTY	TOTAL SHEETS	SHEET NO.
836	**		214	82
			CONTRACT NO. 70D56	

**118RS-3,119RS-4,D5 HSIP 2019-1 *CHAMPAIGN & VERMILION

PROJECTS WITH RECONSTRUCTION

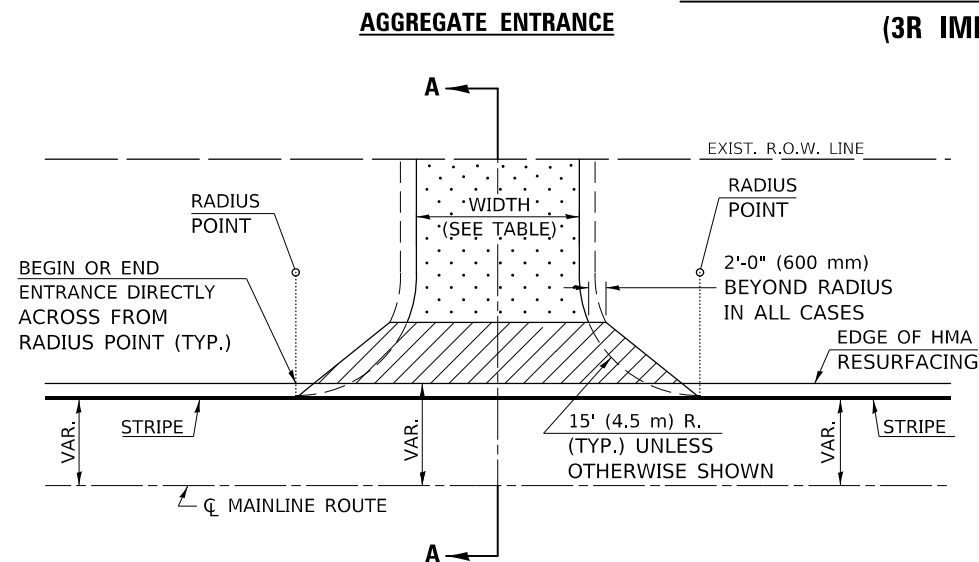

TYPICAL APPLICATION

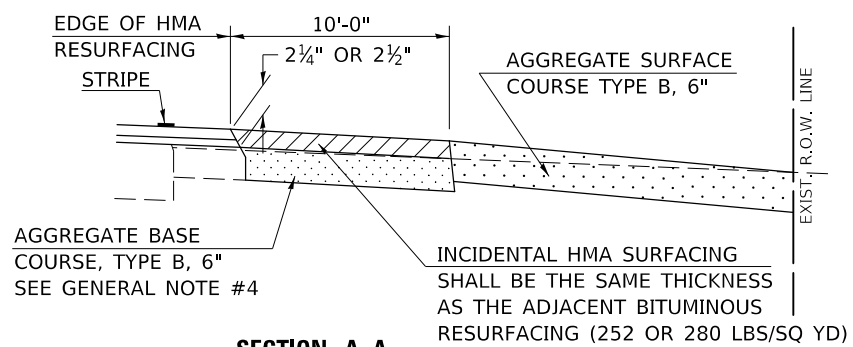

SECTION A-A

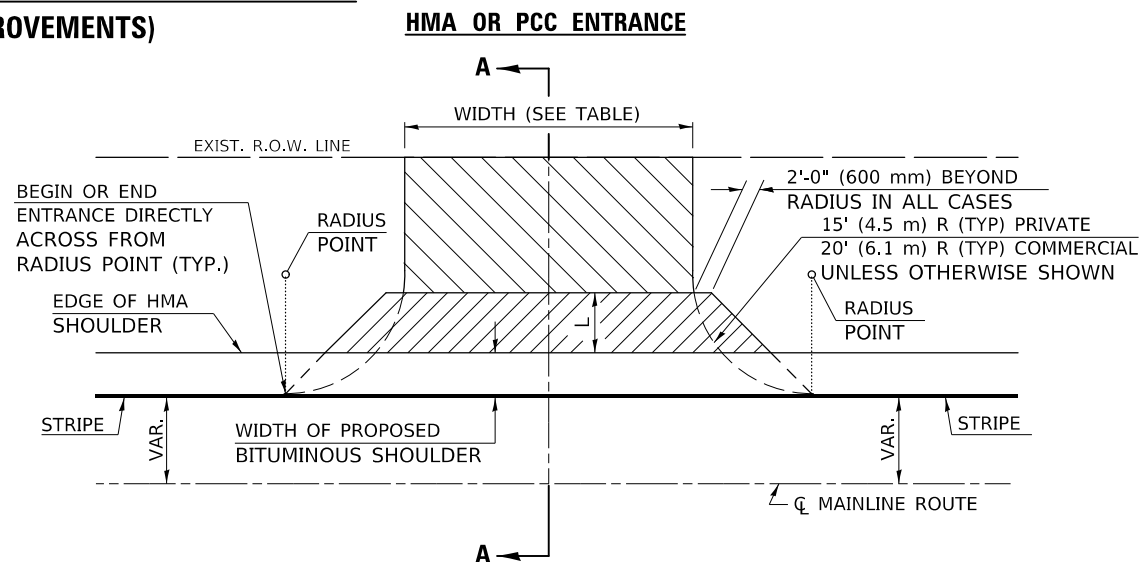

TYPICAL APPLICATION

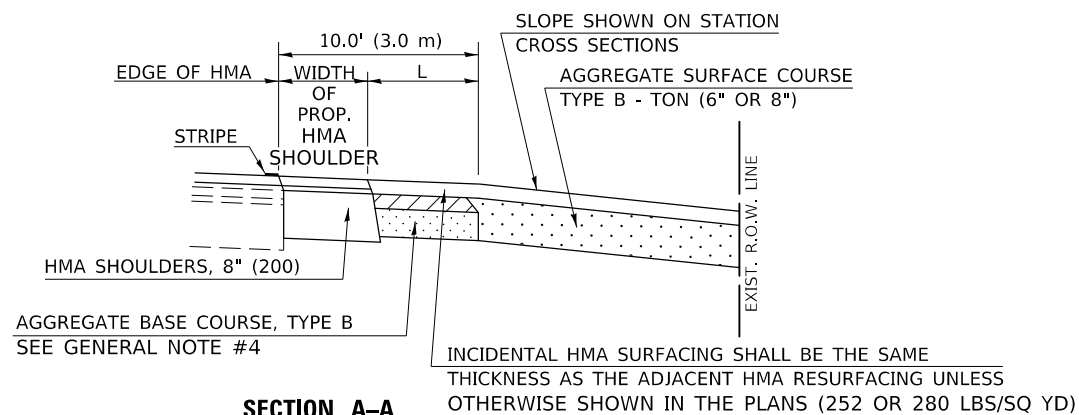

**SECTION A-A
"HMA EXAMPLE"**

GENERAL NOTES

1. THE EXISTING SURFACE SHALL BE PREPARED IN ACCORDANCE WITH SECTION 408 OF THE STANDARD SPECIFICATIONS.
2. ANY NECESSARY WORK BEHIND THE HMA SHOULDER OR THE INCIDENTAL HMA SURFACING SHALL BE AS SHOWN IN THE PLANS AND/OR AS DIRECTED BY THE ENGINEER.
3. EARTH EXCAVATION REQUIRED FOR THE CONSTRUCTION OF THE AGGREGATE SURFACE COURSE SHALL BE INCLUDED IN THE COST OF AGGREGATE SURFACE COURSE.
4. AGGREGATE BASE COURSE, TYPE B, 6" (150 mm) MIN. SHALL BE USED WHERE IN THE OPINION OF THE ENGINEER THERE IS NOT SUFFICIENT BASE MATERIAL FOR THE PROPOSED ENTRANCES. THIS MATERIAL SHALL GENERALLY BE USED TO WIDEN ANY EXISTING RETURN OR TO CONSTRUCT NEW ENTRANCES WHERE NONE NOW EXISTS.
5. THE AGGREGATE BASE COURSE SHALL BE CONSTRUCTED 12" (300 mm) WIDER THAN THE SURFACE DIMENSIONS AS SHOWN ABOVE.
7. EXISTING FIELD ENTRANCES OF AGGREGATE OR EARTH WITH NO HMA APRON SHALL NOT RECEIVE A NEW HMA APRON WITHOUT PROPER APPROVAL THROUGH THE BUREAU OF OPERATIONS "POLICY ON PERMITS FOR ACCESS DRIVEWAYS TO STATE HIGHWAYS".

TO ASSURE APPROPRIATE ACCESS POLICIES ARE FOLLOWED ALL NEW ACCESS SHALL BE APPLIED FOR THROUGH THE BUREAU OF OPERATIONS PERMIT APPLICATION PROCESS. PLAN PREPARATION MEMORANDUMS 40-09 ALONG WITH DISTRICT PROJECT IMPLEMENTATION MEMO 104/01 DISCUSS THIS PROCEDURE.

Note: All dimensions are in INCHES (millimeters) unless otherwise shown.

RURAL ENTRANCE DESIGN STANDARDS (PPM 40-09)															
DESIGN ELEMENT	NEW CONSTRUCTION & 3R with CONSTRUCTION						3R w/out RECONSTRUCTION, 3P, SMART & CM								
	NONCOMMERCIAL			FIELD W/FARM IMPLEMENTS			COMMERCIAL			NONCOMMERCIAL			COMMERCIAL		
	PRIVATE & FIELD					COMMERCIAL	PRIVATE & FIELD					COMMERCIAL			
	min.	des.	max.	min.	max.	min.	des.	max.	min.	des.	max.	min.	des.	max.	
SURFACE WIDTH (FT)	12	16	24	24	30	1 LANE, 1 WAY 14 16 24						1 LANE, 1 WAY			
						2 LANE, 2 WAY 24 30 35						2 LANE, 2 WAY			
RADIUS (FT)	15	25	40	30		20	30	50	resurface existing configuration; existing aggregate or earth entrances shall have the continuation of aggregate shoulders placed behind them						
SHOULDER WIDTH (FT)	2	2		2		1	3								
SHOULDER SLOPE (%)	2	4	6	4		2	4	6							
ENTRANCE GRADE (%)	0	2 to 5	10 or 12	2 to 5	10 or 12	0	2 to 5	8 or 10							
SIDE SLOPE (FT)	1:10	1:6	1:4	1:6	1:4	1:10	1:6	1:4							
SURFACE TYPE															
INCIDENTAL HMA SURFACING (INCH)		2		2		3 or 4			taper from hma resurfacing thickness (2 1/2", 2 1/4" or 1 1/2") to 1 1/2" to minimize aggregate shoulder						
AGGREGATE SURFACE COURSE, TYPE B (INCH)		6		6		8			if applicable, use items: Preparation of Base & Aggregate Base Repair; see PPM 30-02						
PCC DRIVEWAY PAVEMENT (INCH)		6						6 or 8							

DISTRICT 5 DETAIL NO. 40800050C

MODEL: \\MODEL\MNFIS
FILE NAME: P:\p\hmr\conns\data\illinois.gov\PROJECTS\40800050C\Documents\DDOT_Office\Detail.ctb
S:\Projects\40800050C\40800050C\Drawings\40800050C-01-Detail.DWG

USER NAME = PiersonTJ	DESIGNED -	REVISED - 09/07 KAG
	DRAWN -	REVISED - 05/08 KJT
PLOT SCALE = 40.0000' / in.	CHECKED -	REVISED - 04/10 KJT
PLOT DATE = 3/22/2019	DATE -	REVISED - 3/6/17 SWN

**STATE OF ILLINOIS
DEPARTMENT OF TRANSPORTATION**

**PRIVATE COMMERCIAL ENTRANCES
(NONCOMMERCIAL AND COMMERCIAL RURAL)**

SCALE: SHEET 2 OF 2 SHEETS STA. TO STA.

F.A.P. RTE.	SECTION	COUNTY	TOTAL SHEETS	SHEET NO.
836	**		214	83
CONTRACT NO. 70D56				

PROJECTS WITHOUT RECONSTRUCTION

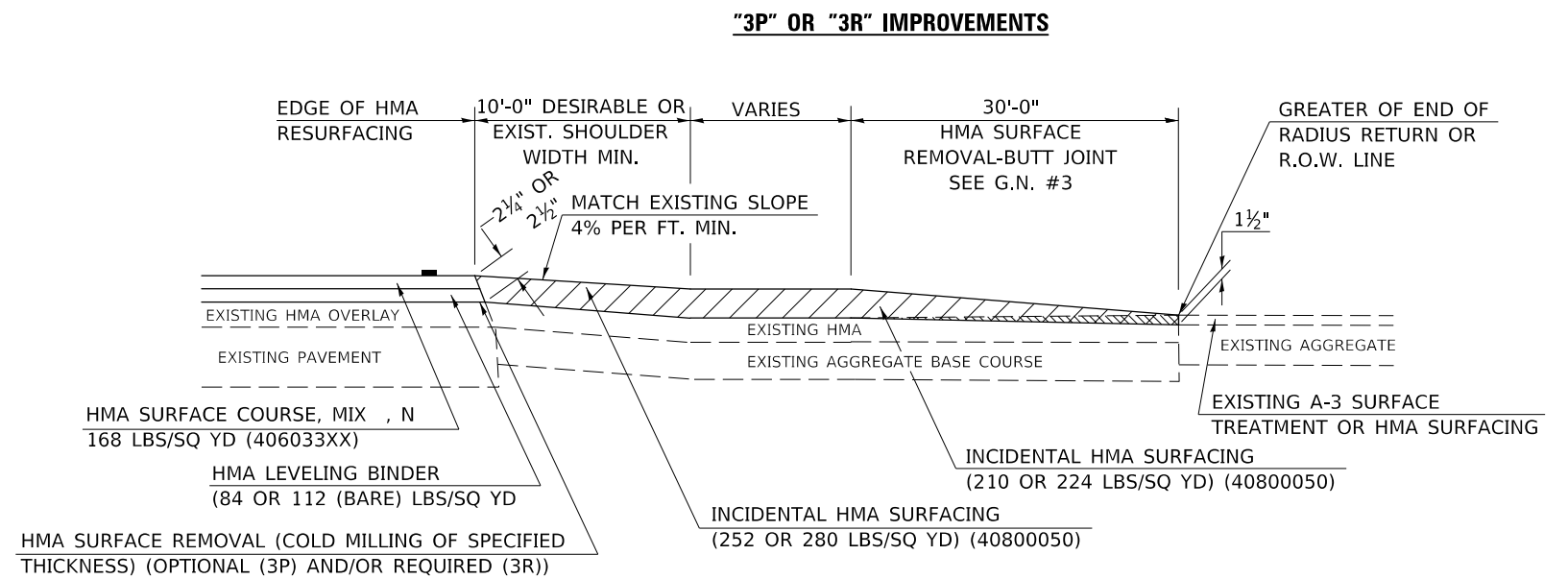
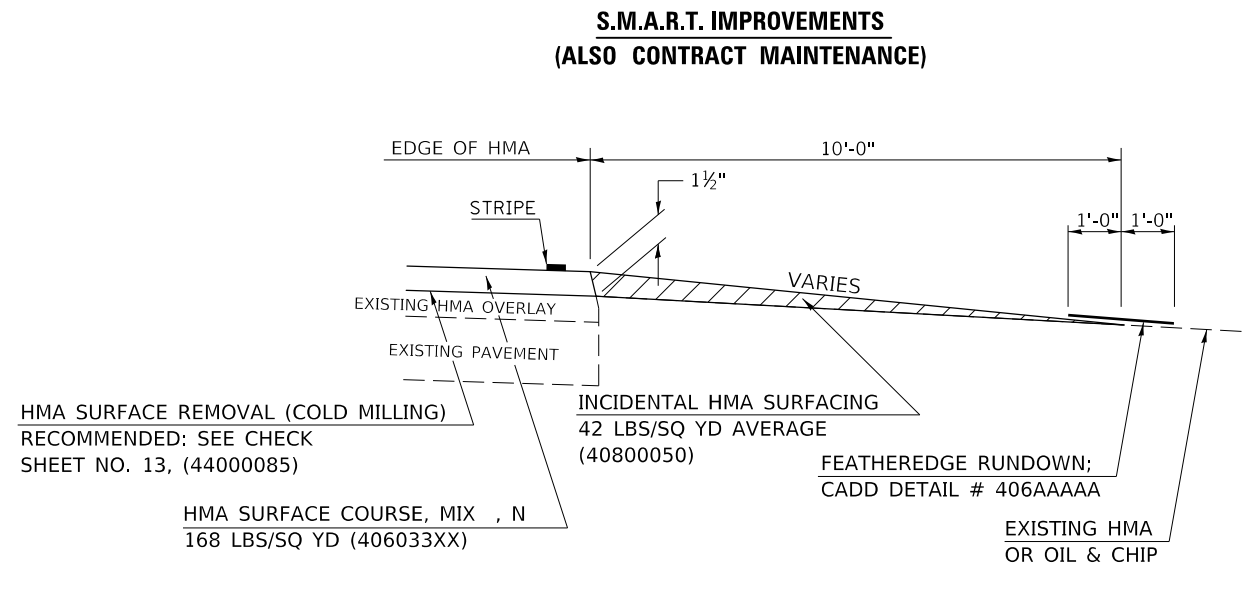

PROJECTS WITH RECONSTRUCTION

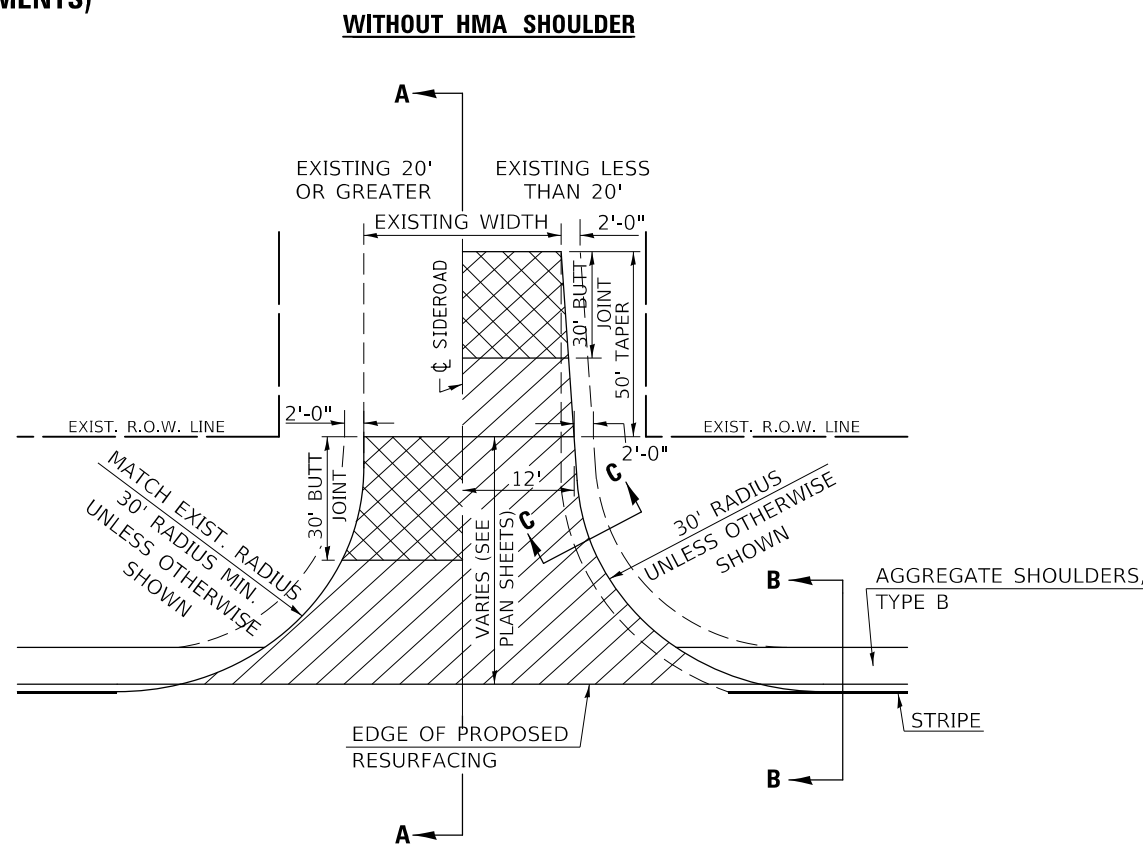
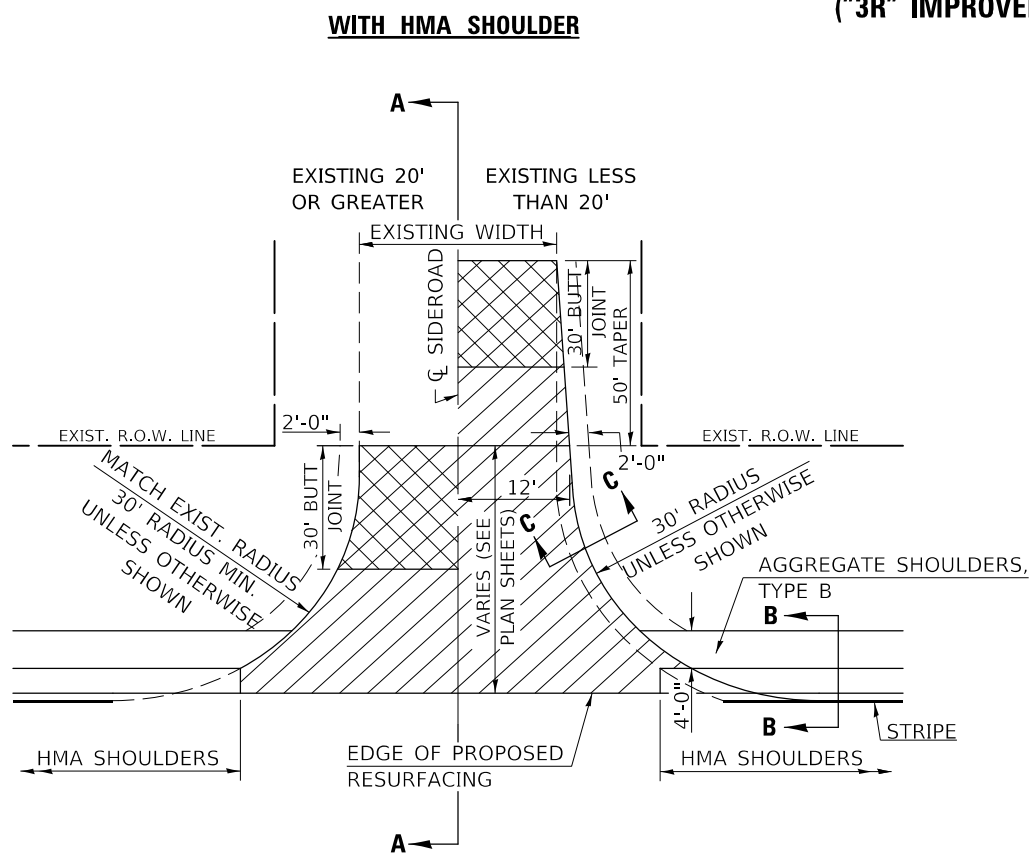

GENERAL NOTES

1. THE EXISTING SURFACE SHALL BE PREPARED IN ACCORDANCE WITH SECTION 408 OF THE STANDARD SPECIFICATIONS
2. PROPOSED SIDEROAD GRADES SHALL BE AS SHOWN IN THE PLANS AND/OR AS DIRECTED BY THE ENGINEER.
3. MAJOR SIDEROAD/SIDESTREETS (>400 ADT) SHALL HAVE "BUTT JOINTS" CONSTRUCTED WHETHER THE EXISTING ENTRANCE IS HMA OR PCC. MINOR SIDEROAD/SIDESTREETS (<400 ADT) SHALL HAVE "FEATHEREDGE RUNDOWNS".
4. AGGREGATE BASE COURSE, TYPE B OF THE THICKNESS SPECIFIED IN THE PLANS 6" MIN. SHALL BE USED WHERE IN THE OPINION OF THE ENGINEER THERE IS NOT 6" EXISTING BASE MATERIAL FOR THE PROPOSED SIDEROAD RETURNS. THIS MATERIAL SHALL BE USED TO WIDEN SIDEROAD RETURNS.
5. THE AGGREGATE BASE COURSE SHALL BE CONSTRUCTED 1' WIDER THAN THE SURFACE DIMENSIONS.
6. AGGREGATE SHOULDERS, TYPE B WILL BE WRAPPED AROUND THE SIDEROAD RETURNS. TAPER WIDTH FROM 4' ALONG MAINLINE TO 2' AT BACK OF RETURN.

Note: All dimensions are in INCHES (millimeters) unless otherwise shown.

DISTRICT 5 DETAIL NO. 408000AA

USER NAME = PiersonTJ	DESIGNED -	REVISED - 12/06 TJB	
	DRAWN -	REVISED - 09/07 KAG	
PLOT SCALE = 40.0000 ' / in.	CHECKED -	REVISED - 12/09 KJT	
PLOT DATE = 3/22/2019	DATE -	REVISED -	

**STATE OF ILLINOIS
DEPARTMENT OF TRANSPORTATION**

SIDEROAD & SIDESTREETS (RURAL)

F.A.P. RTE.	SECTION	COUNTY	TOTAL SHEETS	SHEET NO.
836	**		214	84
CONTRACT NO. 70D56				

MODEL: \\MODEL\MARF5 FILE NAME: P:\p118rs\3,119rs\4,d5\hsip\2019-1\Detail\05 Detail.dgn

**SECTION A-A
EXISTING HMA OR PCC SIDEROAD (> 400 ADT)**

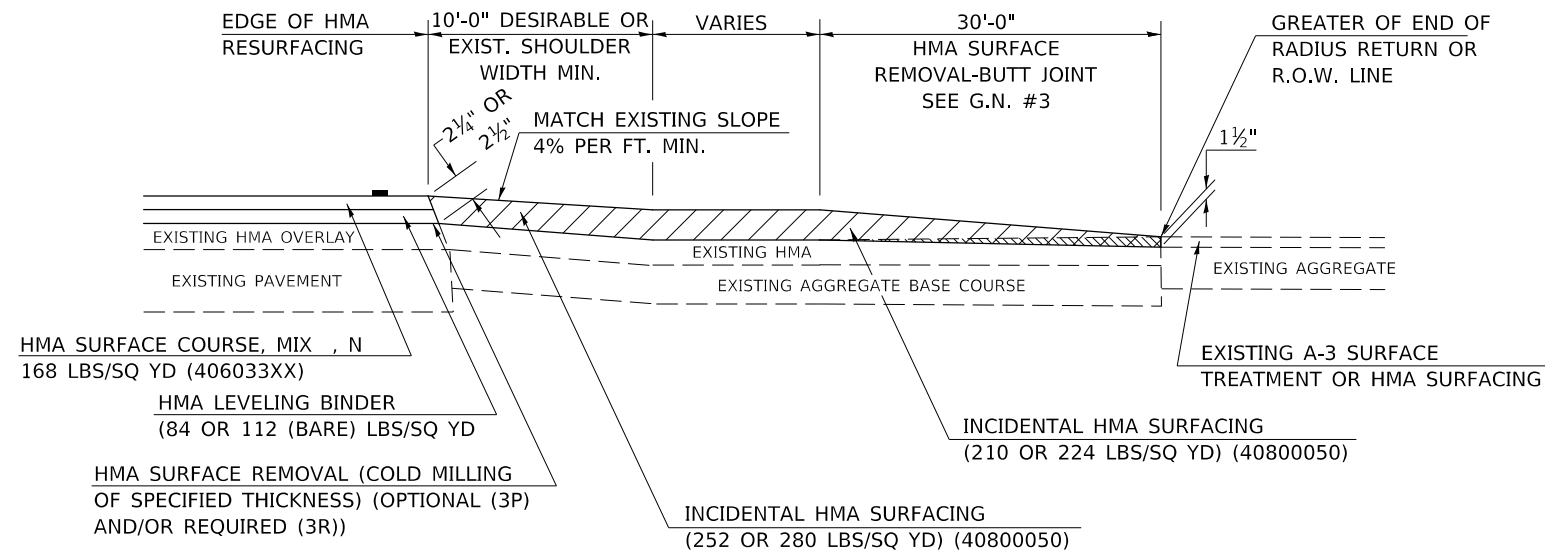

**SECTION A-A
EXISTING AGGREGATE OR SEAL COAT SIDEROAD (< 400 ADT)**

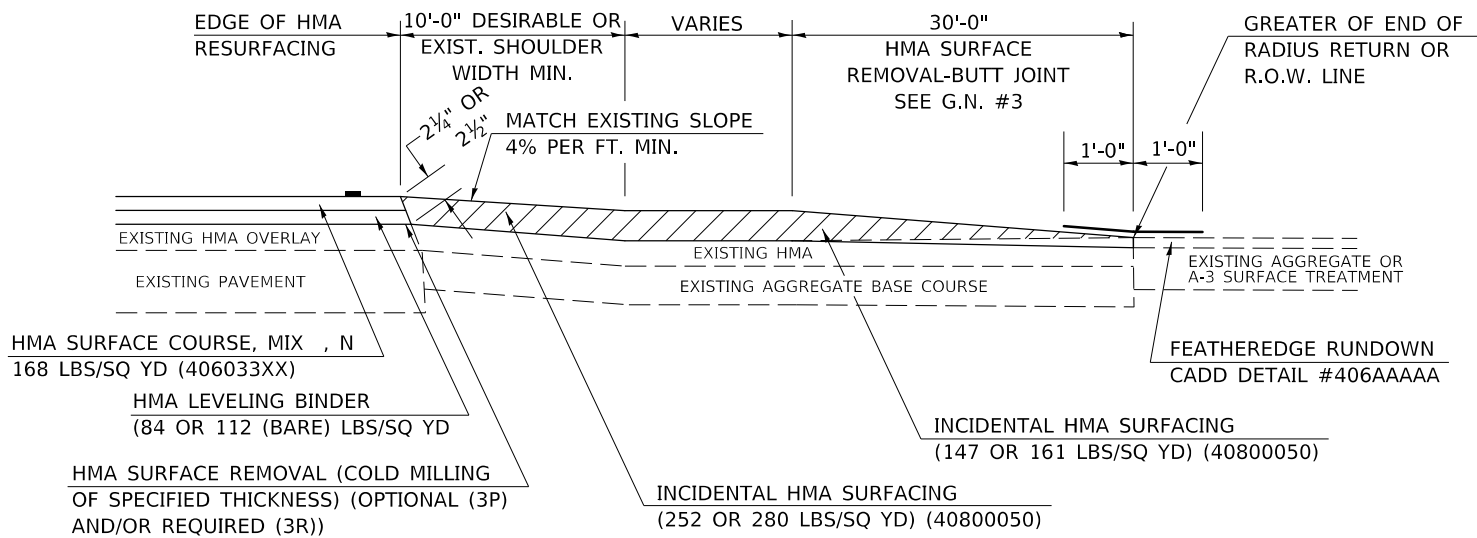

RURAL SIDEROAD DESIGN STANDARDS (PPM 40-06)											
DESIGN ELEMENT	New Construction & 3R (Existing Width Less Than 20 ft)			3R (Existing Width 20 ft or Greater) & 3P			SMART & Contract Maintenance				
	min.	des.	max.	min.	des.	max.	min.	des.	max.		
SURFACE WIDTH (FT); (Measured at end of radius or row line; greatest distance from edge of traveled way)	24	24	Coordinate with Geometrics Engineer	Resurface existing configuration to completion of radius return or row line; greatest distance from edge of traveled way; major sideroads (> 400 adt) shall have "butt joints" constructed whether the entrance is hma or pcc; minor sideroads (< 400 adt) shall have "featheredge rundown" as shown in district cadd detail 406AAAAA						resurface existing configuration with the completion of a 10 ft. featheredge rundown for ALL sideroads as shown in district cadd detail 406AAAAA	
RADIUS (FT)	30	30									
SHOULDER WIDTH (FT)	4	8	10								
SHOULDER SLOPE (%)	2	4	12								
ENTRANCE GRADE (%)	1	1 to 4	4								
BREAKOVER (%)	0	5	10								
SIDE SLOPE (FT)	1:10	1:6	1:4								
INTERSECTION ANGLE	60	75 to 90									
SURFACE TYPE											
INCIDENTAL HMA SURFACING (INCH)	4			taper from 2 1/4" to 1 1/2" or featheredge			taper from 1 1/2" to featheredge				
AGGREGATE BASE COURSE, TYPE A (INCH)	8	4		if applicable use item: 35800100 Preparation of Base							
PCC PAVEMENT (INCH)			8								

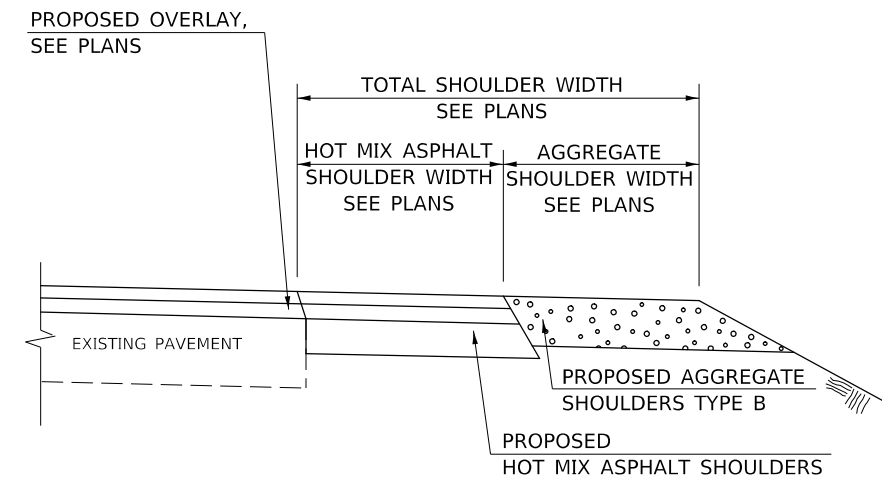

**SECTION B-B
MAINLINE SHOULDER TREATMENT**

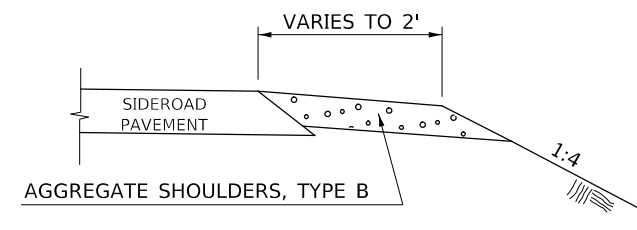

**SECTION C-C
SIDEROAD SHOULDER TREATMENT**

Note: All dimensions are in INCHES (millimeters) unless otherwise shown.

DISTRICT 5 DETAIL NO. 408000AA

USER NAME = PiersonTJ	DESIGNED -	REVISD - 12/06 TJB
	DRAWN -	REVISD - 09/07 KAG
PLOT SCALE = 40.0000' / in.	CHECKED -	REVISD - 12/09 KJT
PLOT DATE = 3/22/2019	DATE -	REVISD -

**STATE OF ILLINOIS
DEPARTMENT OF TRANSPORTATION**

SIDEROAD & SIDESTREETS (RURAL)

SCALE: SHEET 2 OF 2 SHEETS STA. TO STA.

F.A.P. RTE.	SECTION	COUNTY	TOTAL SHEETS	SHEET NO.
836	**	-	214	85
CONTRACT NO. 70D56				

MODEL: s:\MODEL\MHFS
FILE: MHFS_Plan\Illinois\dot\Office\Detail.ctb
S:\Projects\0570D56\CADD\Detail\0570D56-ht-Detail.D5 Detail.dgn

MODEL: \\MODELNAME
 FILE NAME: \\FILENAME
 PROJECT: \\PROJECTNAME
 OFFICE: \\OFFICE
 DESIGNED: \\DESIGNED
 DRAWN: \\DRAWN
 CHECKED: \\CHECKED
 DATE: \\DATE
 PLOT SCALE: \\PLOT SCALE
 PLOT DATE: \\PLOT DATE

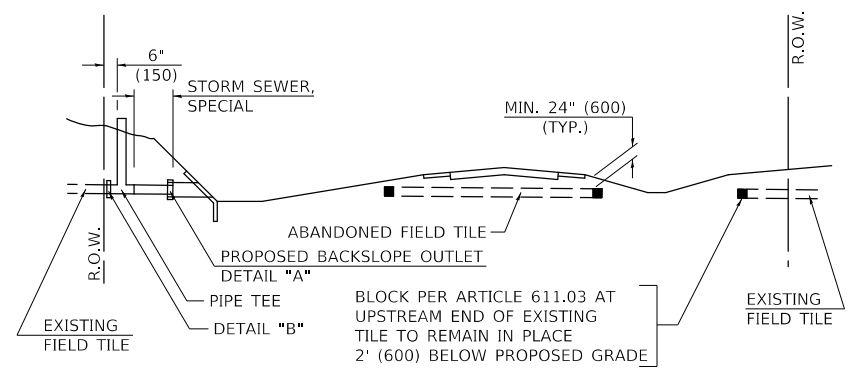

METHOD 'A' (2 LANE)

STORM SEWER FLOW LINE ABOVE PROPOSED DITCH FLOW LINE

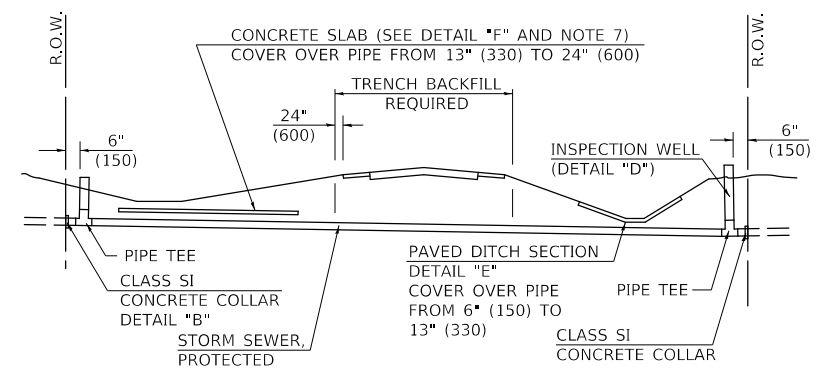

METHOD 'B' (2 LANE)

STORM SEWER LESS THAN 2' (600 mm) BELOW DITCH FLOW LINE AND STORM SEWERS CROSSING UNDER PAVEMENT AND PAVED DITCH

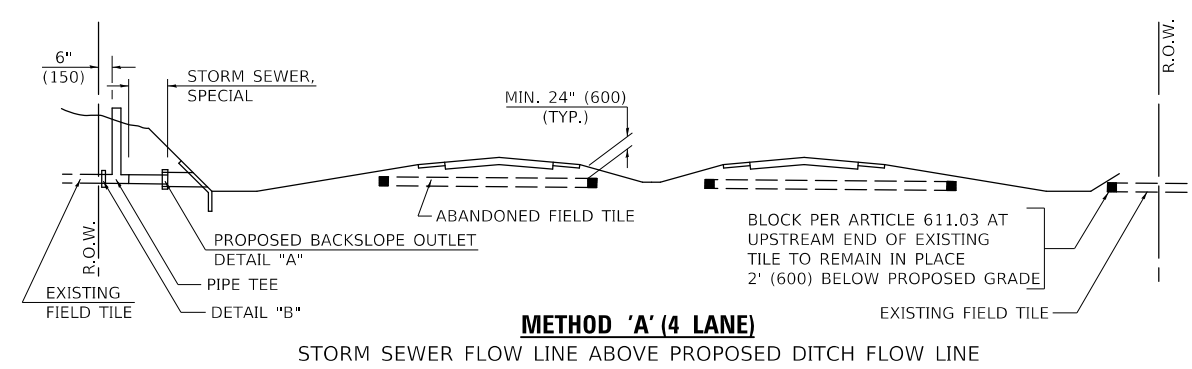

METHOD 'A' (4 LANE)

STORM SEWER FLOW LINE ABOVE PROPOSED DITCH FLOW LINE

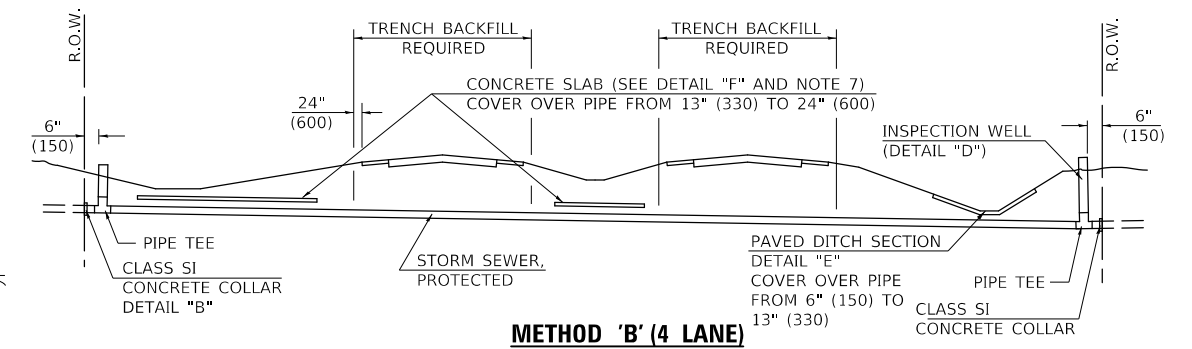

METHOD 'B' (4 LANE)

STORM SEWER LESS THAN 2' (600 mm) BELOW DITCH FLOW LINE AND STORM SEWERS CROSSING UNDER PAVEMENTS AND PAVED DITCHES

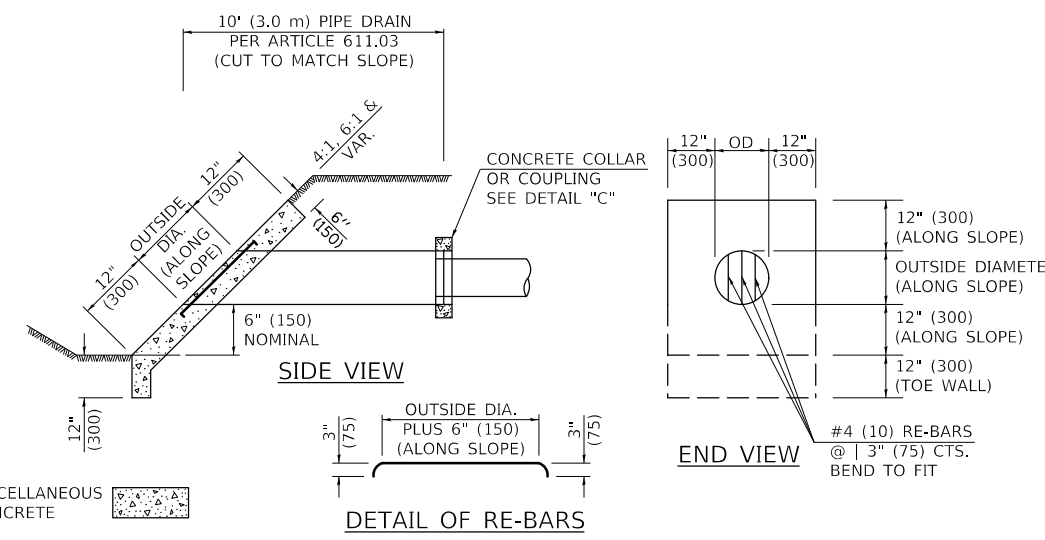

**HEADWALL FOR BACKSLOPE OUTLET
DETAIL "A"**

CONCRETE PIPE STANDARD SIZES	
STORM SEWER	RISER
6" (150)	6" (150)
8" (200)	6" (150)
10" (250)	8" (200)
12" (300)	8" (200)
OR GREATER	10" (250)

FOR PLASTIC PIPE, THE RISER MAY BE OF THE SAME SIZE AS THE PIPE, BUT SHALL NOT BE SMALLER THAN 4" (100 mm) DIAMETER.

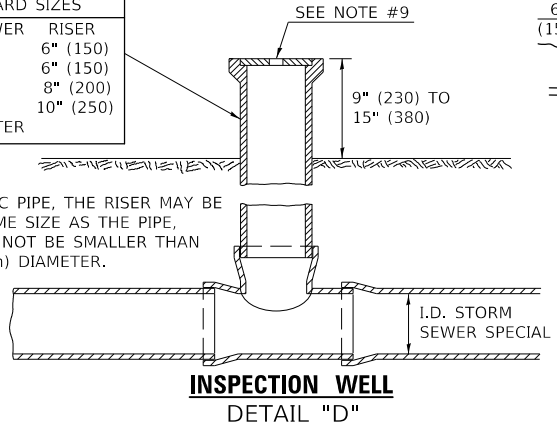

**INSPECTION WELL
DETAIL "D"**

GENERAL NOTES

- EXISTING FIELD TILE ENCOUNTERED BY EXPLORATION TRENCH SHALL BE INSPECTED BY THE ENGINEER FOR UNOBSTRUCTED FLOW WITHIN THE LIMITS OF THE RIGHT-OF-WAY.
- ONLY FIELD TILE THAT DOES NOT HAVE SATISFACTORY FLOW AND OR HAS VISIBLE SIGNS OF DETERIORATION (SINK HOLES, ETC.) SHALL BE REPLACED WITHIN THE LIMITS OF THE RIGHT-OF-WAY IN ACCORDANCE WITH METHOD "B".
- INSPECTION WELLS SHALL BE CONSTRUCTED APPROXIMATELY 6" (150 mm) INSIDE OF BOTH RIGHT-OF-WAY LINES AT ALL FIELD TILE LOCATIONS.
- EXISTING FIELD TILE ABANDONED UNDER EXISTING PAVEMENTS OR PAVED SHOULDERS SHALL BE FILLED WITH FLOWABLE GROUT AS DIRECTED BY THE ENGINEER. THIS WORK WILL BE PAID FOR ACCORDING TO ARTICLE 109.04.
- NON-CIRCULAR FIELD TILE SHALL BE REPLACED WITH STORM SEWER, SPECIAL OF AT LEAST THE SAME CROSS SECTIONAL AREA. ALL EXISTING FIELD TILE SHALL BE REPLACED WITH STORM SEWER OF THE TYPE REQUIRED FOR THE MINIMUM DEPTH OF COVER.
- THE 6" (150 mm) CONCRETE SLAB OR DITCH LINING SHALL BE POURED THE LENGTH OF THE TRENCH AT ALL DITCH FLOW LINE LOCATIONS WITHIN THE RIGHT-OF-WAY WITH LESS THAN 2' (600 mm) OF EARTH COVER. MISCELLANEOUS CONCRETE SHALL BE USED ACCORDING TO SECTION 611.
- ALL MISCELLANEOUS SLABS, APRONS AND DITCH LININGS SHALL BE REINFORCED WITH WELDED WIRE FABRIC AS SHOWN FOR PAVED DITCH IN STANDARD 606401.
- HEADWALL FOR BACKSLOPE OUTLET MAY BE USED FOR PIPE DRAIN DIAMETERS UP TO 10" (250 mm). SPECIAL DESIGNS WILL BE REQUIRED FOR LARGER SIZES.
- THE INSPECTION WELL LID FOR P.C.C. PIPE SHALL BE CONSTRUCTED OF 3/8" (10 mm) CAST IRON AND PROVIDED WITH A 1" (25 mm) DIAMETER HOLE IN CENTER. THE LID FOR THE OTHER PIPE MATERIALS SHALL BE A GRATE ASSEMBLY PREFABRICATED FOR AND COMPATIBLE WITH THE PIPE SYSTEM.

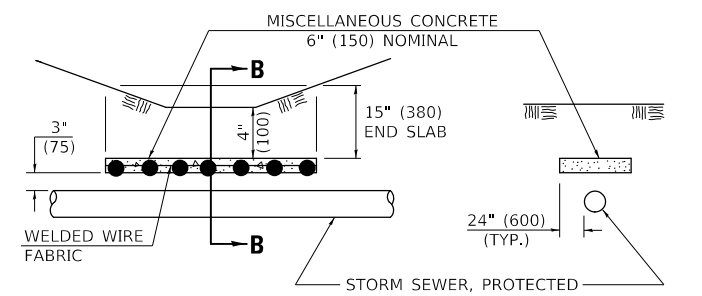

SLAB ELEVATION

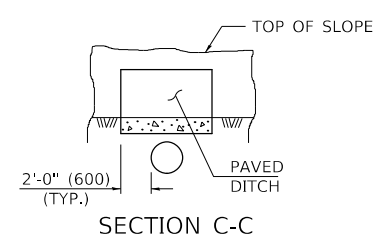

**PAVED DITCH
DETAIL "E"**

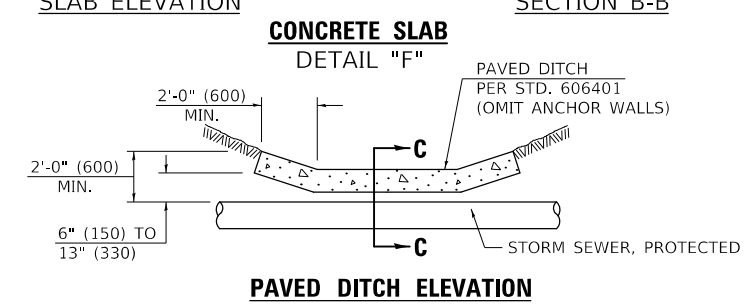

PAVED DITCH ELEVATION

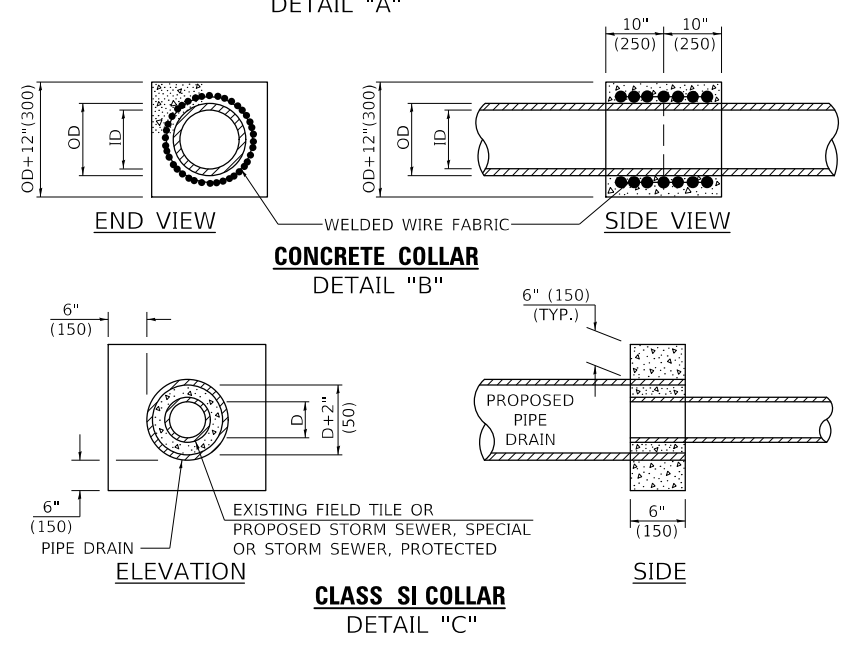

**CONCRETE COLLAR
DETAIL "B"**

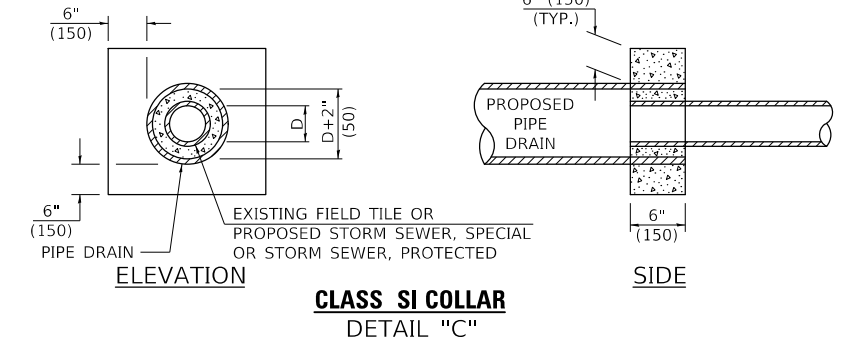

**CLASS SI COLLAR
DETAIL "C"**

Note: All dimensions are in INCHES (millimeters) unless otherwise shown.

DISTRICT 5 DETAIL NO. 61101011A

USER NAME = PiersonTJ	DESIGNED -	REVISED - 11/06
	DRAWN -	REVISED -
PLOT SCALE = 40.0000' / in.	CHECKED -	REVISED -
PLOT DATE = 3/22/2019	DATE -	REVISED -

**STATE OF ILLINOIS
DEPARTMENT OF TRANSPORTATION**

FIELD TILE SYSTEMS (TREATMENT OF EXISTING)

SCALE:	SHEET 1 OF 1 SHEETS	STA. TO STA.
--------	---------------------	--------------

F.A.P. RTE.	SECTION	COUNTY	TOTAL SHEETS	SHEET NO.
836	**	-	214	86
CONTRACT NO. 70D56				
ILLINOIS FED. AID PROJECT				

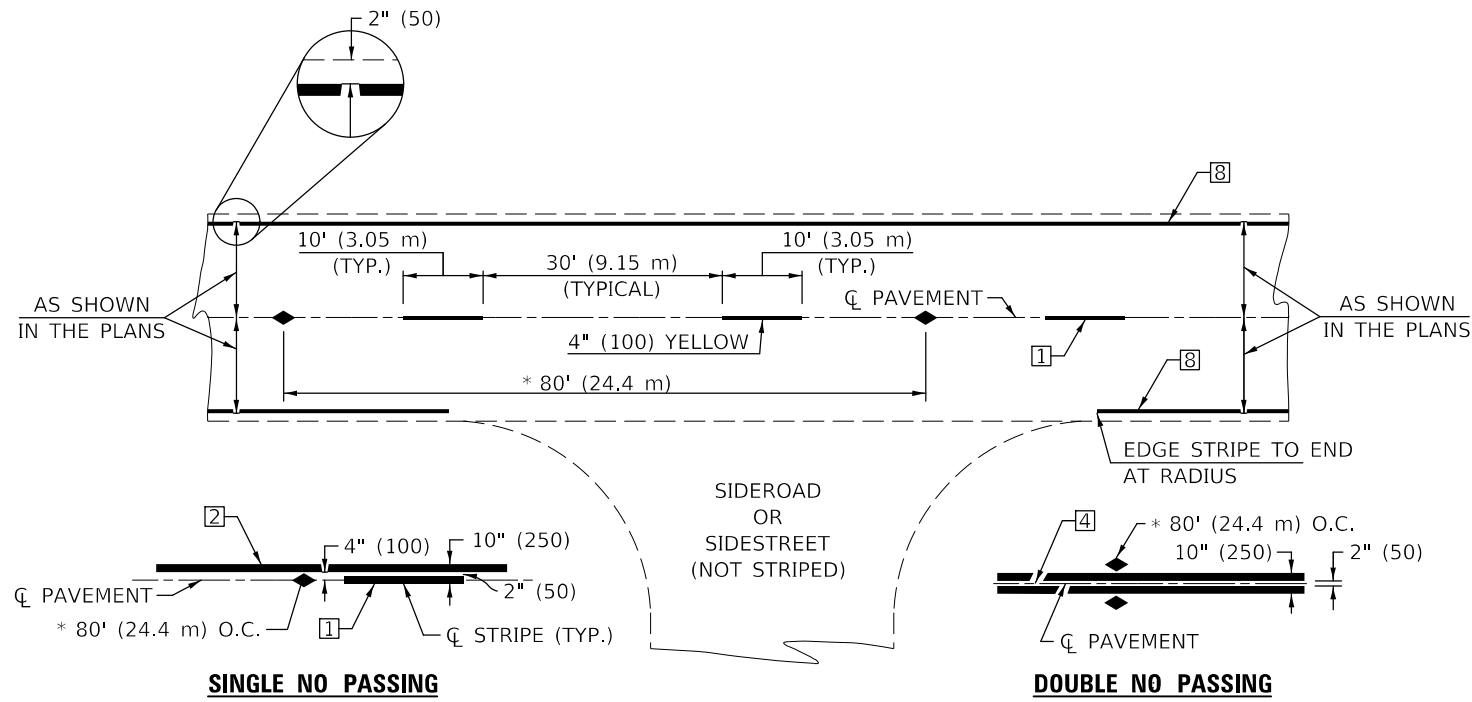

TWO LANE/TWO WAY

TYPICAL PAVEMENT MARKING LEGEND

- 1 4" (100) SKIP-DASH (YELLOW)
- 2 4" (100) SOLID (YELLOW)
- 3 12" (300) DIAGONAL (YELLOW)
- 4 4" (100) DOUBLE YELLOW (NARROW)
- 5 RESERVED
- 6 RESERVED
- 7 4" (100) SKIP-DASH (WHITE)
- 8 4" (100) SOLID (WHITE)
- 9 12" (300) DIAGONAL (WHITE)
- 10 6" (150) SOLID (WHITE)
- 11 24" (600) STOP BAR (WHITE)
- 12 8" (200) SOLID (WHITE)
- 13 4" (100) LANE LINE EXTENSIONS (WHITE)
- 14 4" (100) PARKING WHITE

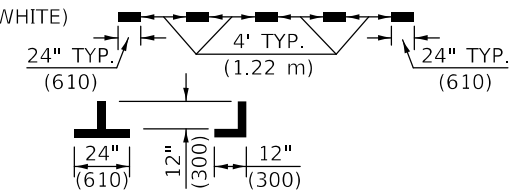
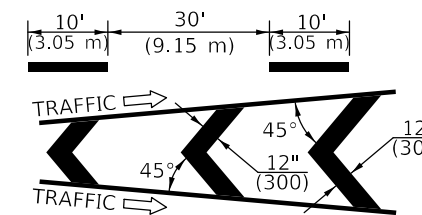
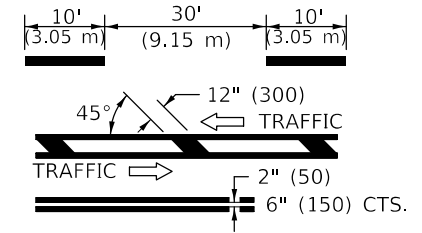

TYPICAL PAVEMENT MARKERS LEGEND

- ◆ TWO-WAY AMBER MARKER
- ▶ ONE-WAY AMBER MARKER
- ▷ ONE-WAY CRYSTAL MARKER

RURAL LEFT TURN

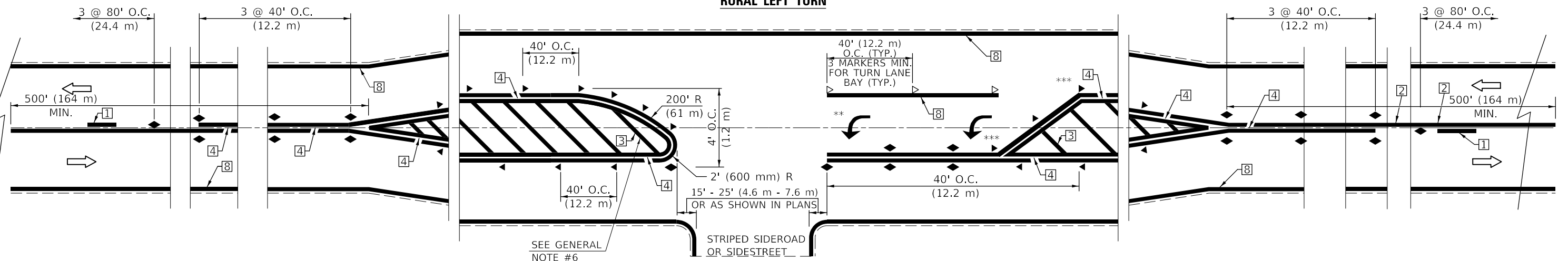

*** REDUCE SPACING IF NECESSARY TO ASSURE MARKERS AT CORNER POINTS.
 ** TURN ARROWS SHALL BE PLACED AS SHOWN ON SHEET #2.

Note: All dimensions are in INCHES (millimeters) unless otherwise shown.

DISTRICT 5 DETAIL NO. 7800AAAA

USER NAME = PiersonTJ	DESIGNED -	REVISED - 11/06
	DRAWN -	REVISED - 9/2009 KJT
PLOT SCALE = 40.0000" / in.	CHECKED -	REVISED - 04/14 JLA
PLOT DATE = 3/22/2019	DATE -	REVISED - 3/2019 SWN

**STATE OF ILLINOIS
DEPARTMENT OF TRANSPORTATION**

**PAVEMENT MARKING AND MARKERS
(RURAL & URBAN APPLICATIONS)**

F.A.P. RTE.	SECTION	COUNTY	TOTAL SHEETS	SHEET NO.
836	**	-	214	87
CONTRACT NO. 70D56				

SCALE: SHEET 1 OF 4 SHEETS STA. TO STA.

MODEL: I:\MODEL\MARF... FILE NAME: P:\pblm\comdata\illinois\gov\PIWDOT\Documents\DOT_Offices\District 5\Projects\DS720D56\CAD\DetailDesign\DS720D56-PL-Detail.D5 Detail.dgn

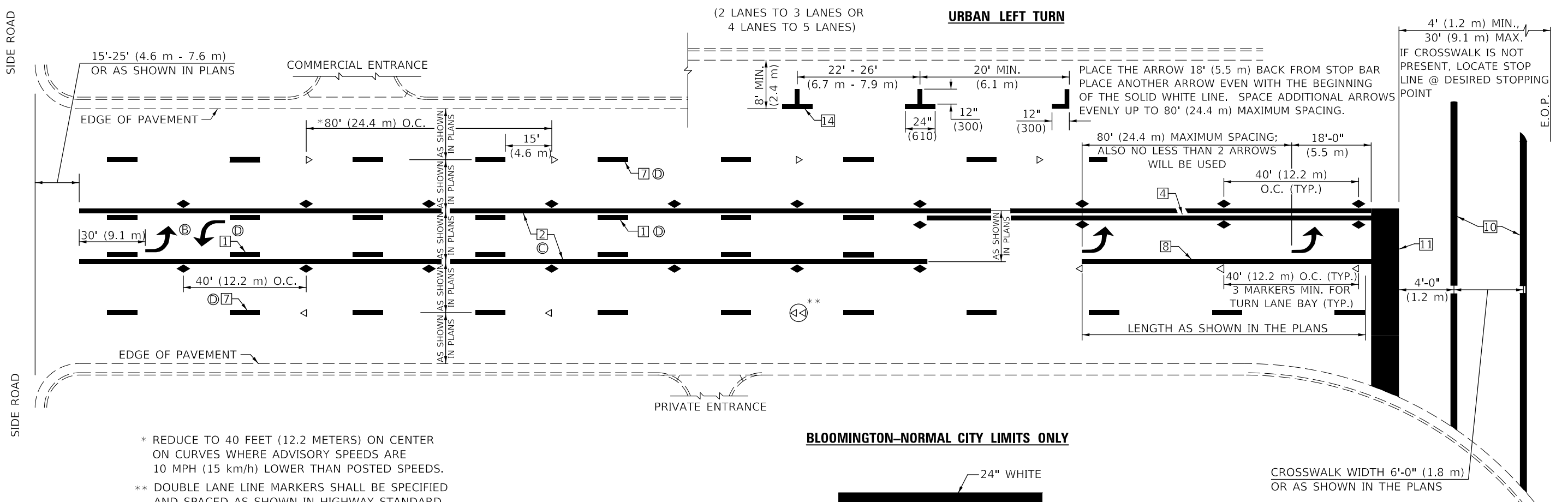

- GENERAL NOTES:**
- Ⓑ TURN ARROW PAIRS SHALL BE PLACED AT 250' (75 m) INTERVALS AND SHALL BE EVENLY SPACED BETWEEN BOTH ENDS OF THE BIDIRECTIONAL LEFT TURN LANE.
 - Ⓒ THE SOLID YELLOW PAVEMENT MARKINGS [2] SHOULD GENERALLY START OR END NEAR THE RADIUS POINT OF EACH STREET RETURN EXCEPT WHERE ONE OR BOTH ENDS WOULD INCLUDE STOP BARS.
 - Ⓓ THE SKIP-DASH PAVEMENT MARKINGS [1] OR [7] SHOULD BE CENTERED BETWEEN BOTH ENDS OF EACH CITY BLOCK AND SHALL BE PLACED SO THEY LINE UP ACROSS FROM EACH OTHER. SEE EXAMPLE ON SHEET 2 OF 3.
 - Ⓔ USE LARGE ARROW SIZE FOR BOTH RURAL AND URBAN LOCATIONS. (SEE LAST PAGE OF SECTION 780x FOR SYMBOLS TABLE)

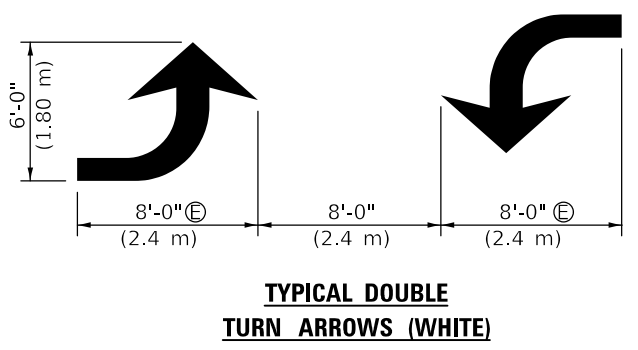
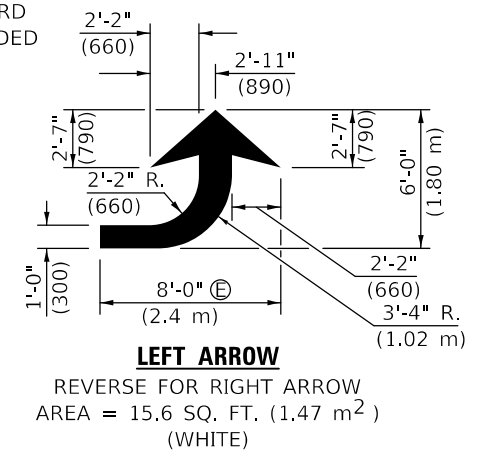

BLOOMINGTON-NORMAL CITY LIMITS ONLY

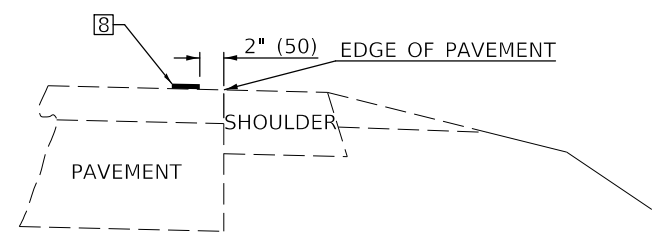
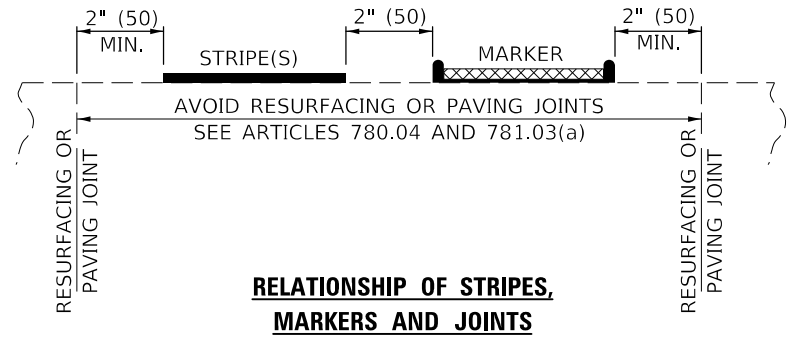
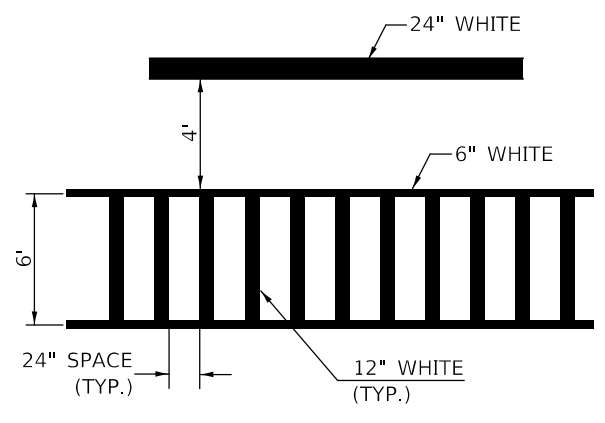

* REDUCE TO 40 FEET (12.2 METERS) ON CENTER ON CURVES WHERE ADVISORY SPEEDS ARE 10 MPH (15 km/h) LOWER THAN POSTED SPEEDS.
** DOUBLE LANE LINE MARKERS SHALL BE SPECIFIED AND SPACED AS SHOWN IN HIGHWAY STANDARD 781001 FOR MULTI-LANE DIVIDED AND UNDIVIDED HIGHWAYS.

Note: All dimensions are in INCHES (millimeters) unless otherwise shown.

MODEL: I:\MODEL\MARKERS
FILE NAME: PavMarkings-70D556-District_5\Projects\05\70D556\CDData\Design\05\70D556-RH-Detail.DWG
PROJECT: 70D556 - District 5 Roadway Construction

USER NAME = PiersonTJ	DESIGNED -	REVISED - 11/06
	DRAWN -	REVISED - 9/2009 KJT
PLOT SCALE = 40.0000 "/in.	CHECKED -	REVISED - 04/14 JLA
PLOT DATE = 3/22/2019	DATE -	REVISED - 3/2019 SWN

**STATE OF ILLINOIS
DEPARTMENT OF TRANSPORTATION**

**PAVEMENT MARKING AND MARKERS
(RURAL & URBAN APPLICATIONS)**

SCALE: SHEET 2 OF 4 SHEETS STA. TO STA.

DISTRICT 5 DETAIL NO. 7800AAAA				
F.A.P. RTE.	SECTION	COUNTY	TOTAL SHEETS	SHEET NO.
836	**	-	214	88
				CONTRACT NO. 70D56
		ILLINOIS	FED. AID PROJECT	**CHAMPAIGN & VERMILION

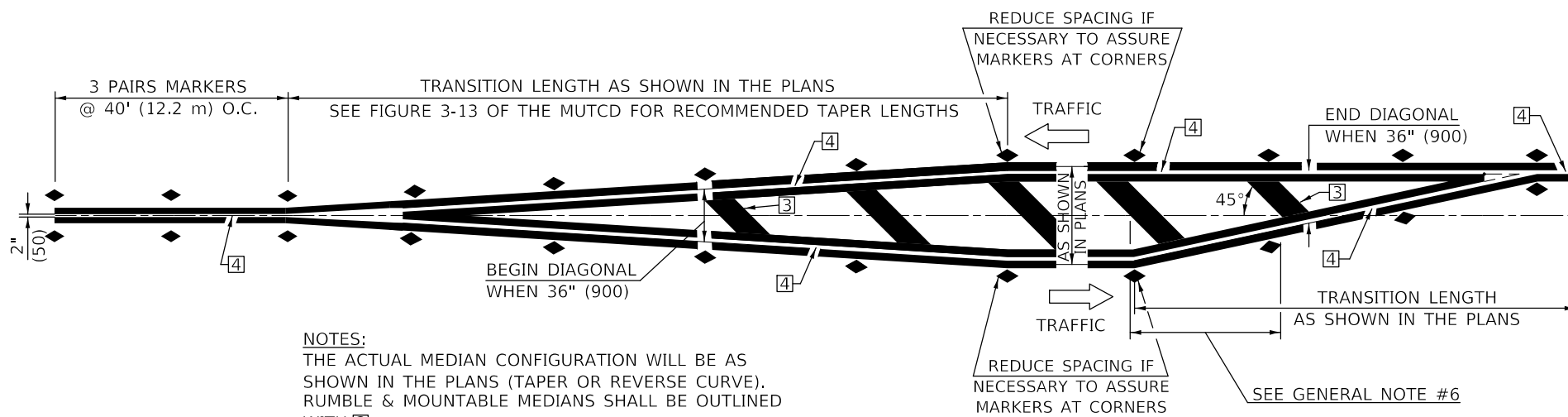

NOTES:
 THE ACTUAL MEDIAN CONFIGURATION WILL BE AS SHOWN IN THE PLANS (TAPER OR REVERSE CURVE). RUMBLE & MOUNTABLE MEDIANS SHALL BE OUTLINED WITH [2].

TYPICAL MEDIAN TRANSITIONS

GENERAL NOTES

1. WHEN MEDIANS ARE PRESENT, PAVEMENT MARKINGS ARE TO BE PLACED ADJACENT TO MEDIANS.
2. SOME OF THE INFORMATION INCLUDED WITH THIS DETAIL MAY NOT BE APPLICABLE TO THIS IMPROVEMENT.
3. PAVEMENT MARKINGS ARE TO BE EXTENDED THROUGH OMISSIONS WHEN APPLICABLE.
4. A STRIPING KEY IS AVAILABLE ELSEWHERE AND SHALL BE SHOWN WHERE THE QUANTITIES ARE LISTED.
5. FINAL PAVEMENT MARKINGS SHALL BE IN PLACE PRIOR TO PLACING ANY RAISED REFLECTIVE PAVEMENT MARKERS.
6. THE FOLLOWING CRITERIA SHALL BE USED FOR SELECTING THE DIAGONAL PAVEMENT MARKING SPACING,
 <30 MPH USE 15' (<50 km/h USE 4.5 m)
 30-45 MPH USE 20' (50-75 km/h USE 6.0 m)
 >45 MPH USE 30' (>75 km/h USE 9.0 m)

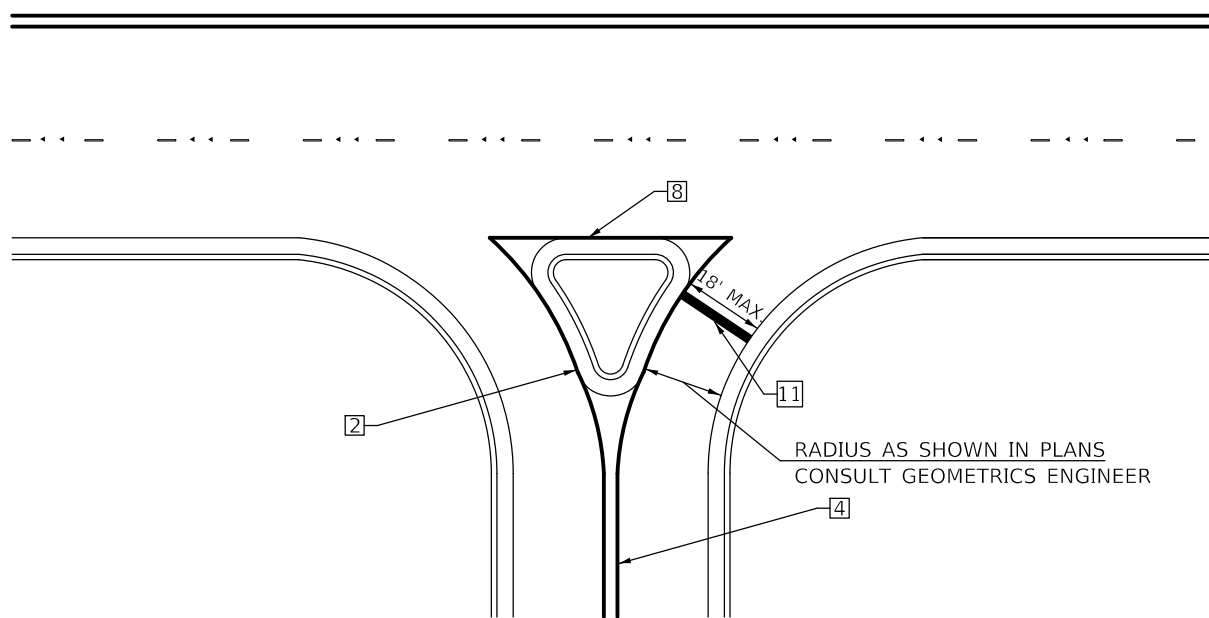

RIGHT IN - RIGHT OUT ACCESS

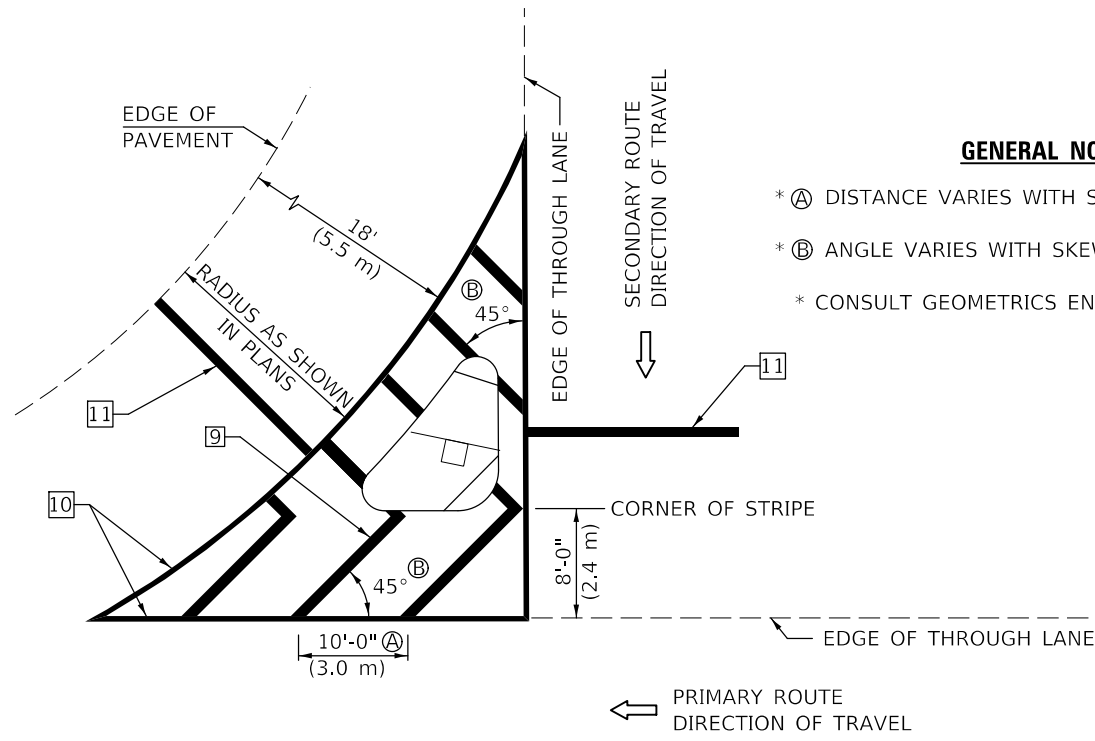

ISLAND

GENERAL NOTES

- * A DISTANCE VARIES WITH SKEW OF INTERSECTION.
- * B ANGLE VARIES WITH SKEW OF INTERSECTION.
- * CONSULT GEOMETRICS ENGINEER

Note: All dimensions are in INCHES (millimeters) unless otherwise shown.

DISTRICT 5 DETAIL NO. 7800AAAA

MODEL: \\MODELNAME
 FILE NAME: \\PLOTNAME
 PROJECT: \\PROJECTNAME
 OFFICE: \\OFFICE
 DESIGNED: \\DESIGNED
 DRAWN: \\DRAWN
 CHECKED: \\CHECKED
 DATE: \\DATE

USER NAME = PiersonTJ	DESIGNED -	REVISED - 11/06
PLOT SCALE = 40.0000' / in.	DRAWN -	REVISED - 9/2009 KJT
PLOT DATE = 3/22/2019	CHECKED -	REVISED - 04/14 JLA
	DATE -	REVISED - 3/2019 SWN

**STATE OF ILLINOIS
 DEPARTMENT OF TRANSPORTATION**

**PAVEMENT MARKING AND MARKERS
 (RURAL & URBAN APPLICATIONS)**

SCALE: SHEET 3 OF 4 SHEETS STA. TO STA.

F.A.P. RTE.	SECTION	COUNTY	TOTAL SHEETS	SHEET NO.
836	**	-	214	89
CONTRACT NO. 70D56				

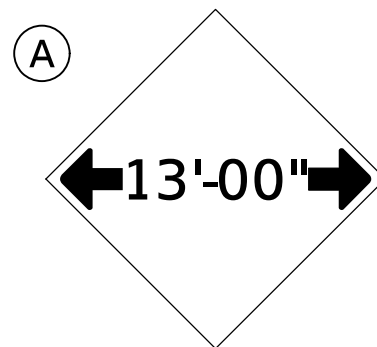

W12-2(O)-48"x48"(1200x1200)

SIGN (A) 2 SIGNS - W12-2(O)-48"x48"(1200x1200) ARE TO BE PLACED AS SHOWN IN THE PLANS OR AS DIRECTED BY THE ENGINEER.

SIGN (B) 2 SIGNS - (SIGN PANEL, TYPE II) AS SHOWN ARE TO BE PLACED AS SHOWN IN THE PLANS OR AS DIRECTED BY THE ENGINEER.

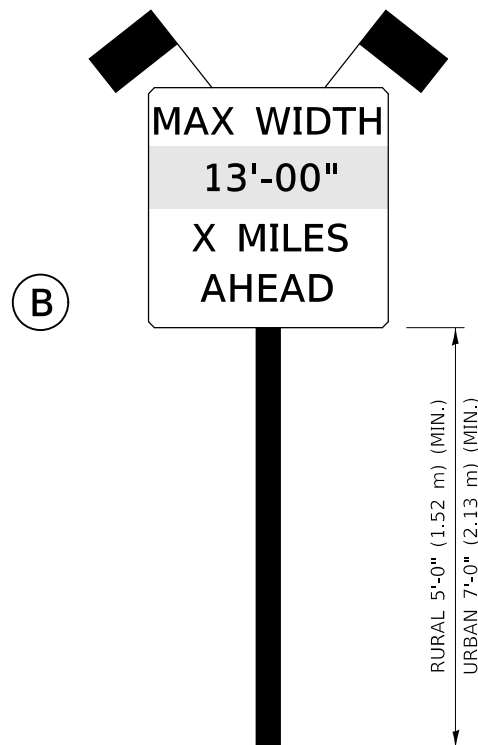

SIGN PANEL, TYPE II

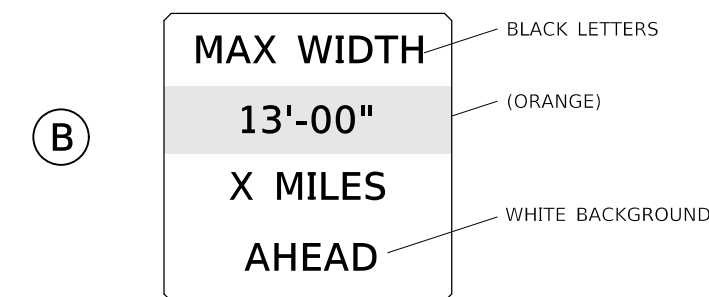

W12-I103(O)-48"x48"(1200x1200)
"D" LETTERS/NUMBERS

GENERAL NOTES

1. ALL TRAFFIC CONTROL DEVICES SHALL BE FURNISHED, ERECTED AND MAINTAINED BY THE CONTRACTOR.
2. ALL (B) SIGNS SHALL HAVE FLAGS INSTALLED UNLESS OTHERWISE DIRECTED.
3. LOCATIONS OF TRAFFIC CONTROL DEVICES MAY BE ADJUSTED BY THE ENGINEER.
4. ALL TRAFFIC CONTROL SHOWN ON THIS SHEET SHALL BE PAID FOR AT THE CONTRACT LUMP SUM PRICE FOR WIDTH RESTRICTION SIGNING.
5. ALL SIGNS SHALL BE POST MOUNTED UNLESS OTHERWISE DIRECTED.
6. ALL SIGNS SHOWN ORANGE (O) SHALL BE FLUORESCENT ORANGE.
7. ALL SIGNS SHOWN SHALL CONSIST OF THE CURRENT RETROREFLECTIVE SHEETING REQUIREMENTS AS OUTLINED IN SECTION 1106.01 OF THE STANDARD SPECIFICATIONS BOOK.

Note: All dimensions are in INCHES (millimeters) unless otherwise shown.

MODEL: s:\MODEL\MHFE
FILE NAME: p:\gpin\mcom\data\illinois.gov\PI\DOT\Documents\DOT_Offices\District 5\Projects\ID570D56\CADD\Design\ID570D56-41-Detail.D5 Detail.dgn

USER NAME = PiersonTJ	DESIGNED -	REVISED - 05/08
	DRAWN -	REVISED - 10/08 KJT
PLOT SCALE = 40.0000 ' / in.	CHECKED -	REVISED - 07/09 KJT
PLOT DATE = 3/28/2019	DATE -	REVISED - 03/11 KJT

**STATE OF ILLINOIS
DEPARTMENT OF TRANSPORTATION**

WIDTH RESTRICTION SIGNING

SCALE: SHEET 1 OF 1 SHEETS STA. TO STA.

DISTRICT 5 DETAIL NO. X7200201

F.A.P. RTE.	SECTION	COUNTY	TOTAL SHEETS	SHEET NO.
836	**	-	214	91
				CONTRACT NO. 70D56

**118RS-3,119RS-4,D5 HSIP 2019-1

*CHAMPAIGN & VERMILION

DATE	
BY	
FINAL SURVEY	SURVEYED
NOTE BOOK	PLOTTED
NO.	TEMPLATE
	AREAS CHECKED
	AREAS CHECKED

DATE	
BY	
ORIGINAL SURVEY	SURVEYED
NOTE BOOK	PLOTTED
NO.	TEMPLATE
	AREAS CHECKED
	AREAS CHECKED

MODEL: S:\MODEL\NAMES
 FILE NAME: D:\gablan\com.d\Illinois\p\PIVIDOT\Documents\DOT Office\District 3\Project\0570D56\CADD\Drawn\Design\0570D56\csh-Cross_Section.dgn

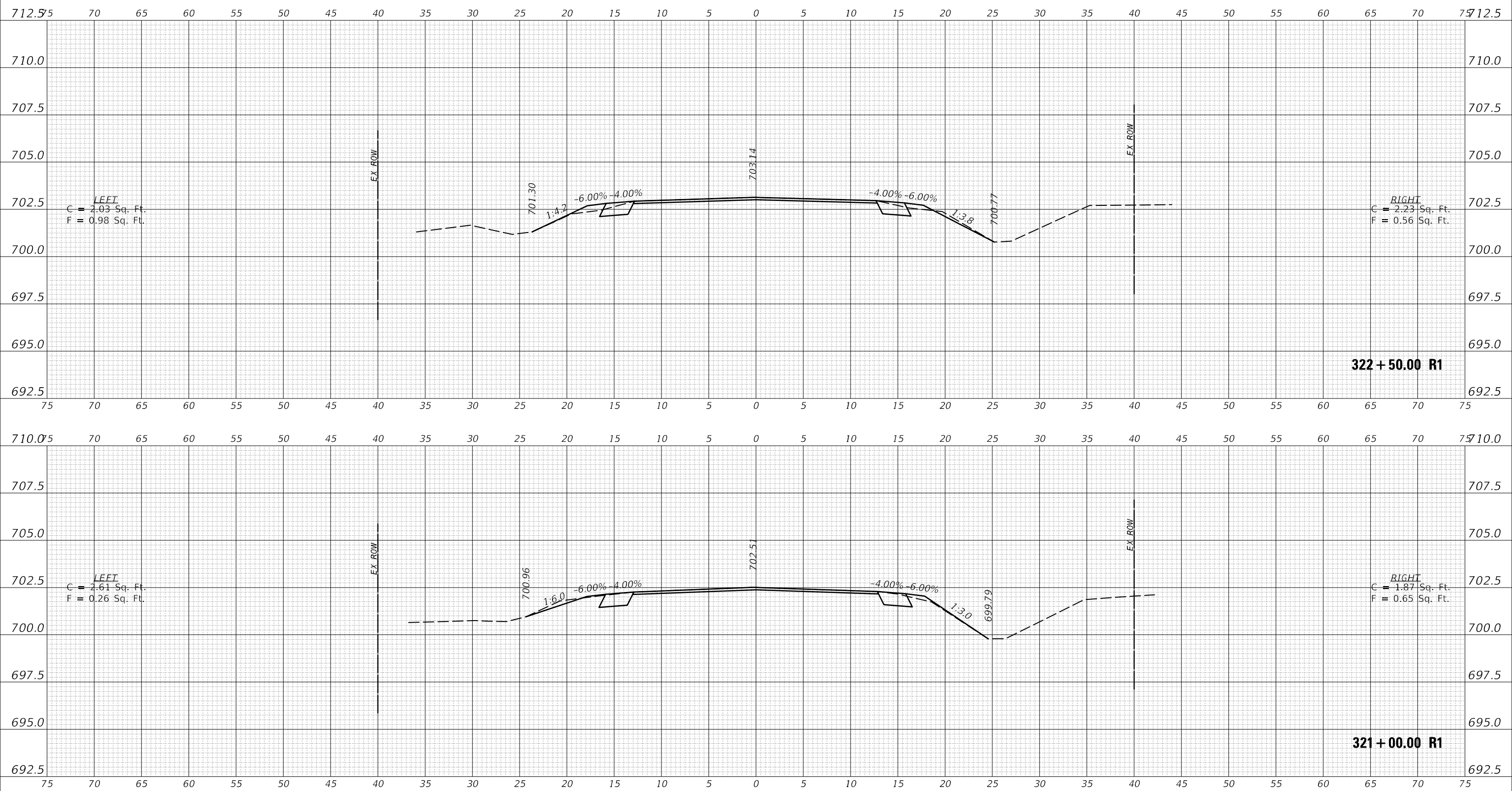

USER NAME = PiersonTJ	DESIGNED -	REVISED -
	DRAWN -	REVISED -
PLOT SCALE = 10.0000 ' / in.	CHECKED -	REVISED -
PLOT DATE = 3/22/2019	DATE -	REVISED -

**STATE OF ILLINOIS
 DEPARTMENT OF TRANSPORTATION**

IL-49 CROSS-SECTIONS	
SCALE:	SHEET 1 OF 120 SHEETS
STA. 321+00.00 R1 TO STA. 322+50.00 R1	

F.A.P. RTE. 836	SECTION **	COUNTY *	TOTAL SHEETS 214	SHEET NO. 92
CONTRACT NO. 70D56				

FINAL SURVEY	SURVEYED	DATE
NOTE BOOK	PLOTTED	BY
NO.	TEMPLATE	
	AREAS CHECKED	
	AREAS	
	CHECKED	

ORIGINAL SURVEY	SURVEYED	DATE
NOTE BOOK	PLOTTED	BY
NO.	TEMPLATE	
	AREAS CHECKED	
	AREAS	
	CHECKED	

MODEL: S:\MODEL\NAMES
 FILE NAME: D:\gablenom.d\Illinois\p\PROJECTS\70D56\CADD\Drawn\Design\70D56\5th-Cross_Section.dgn

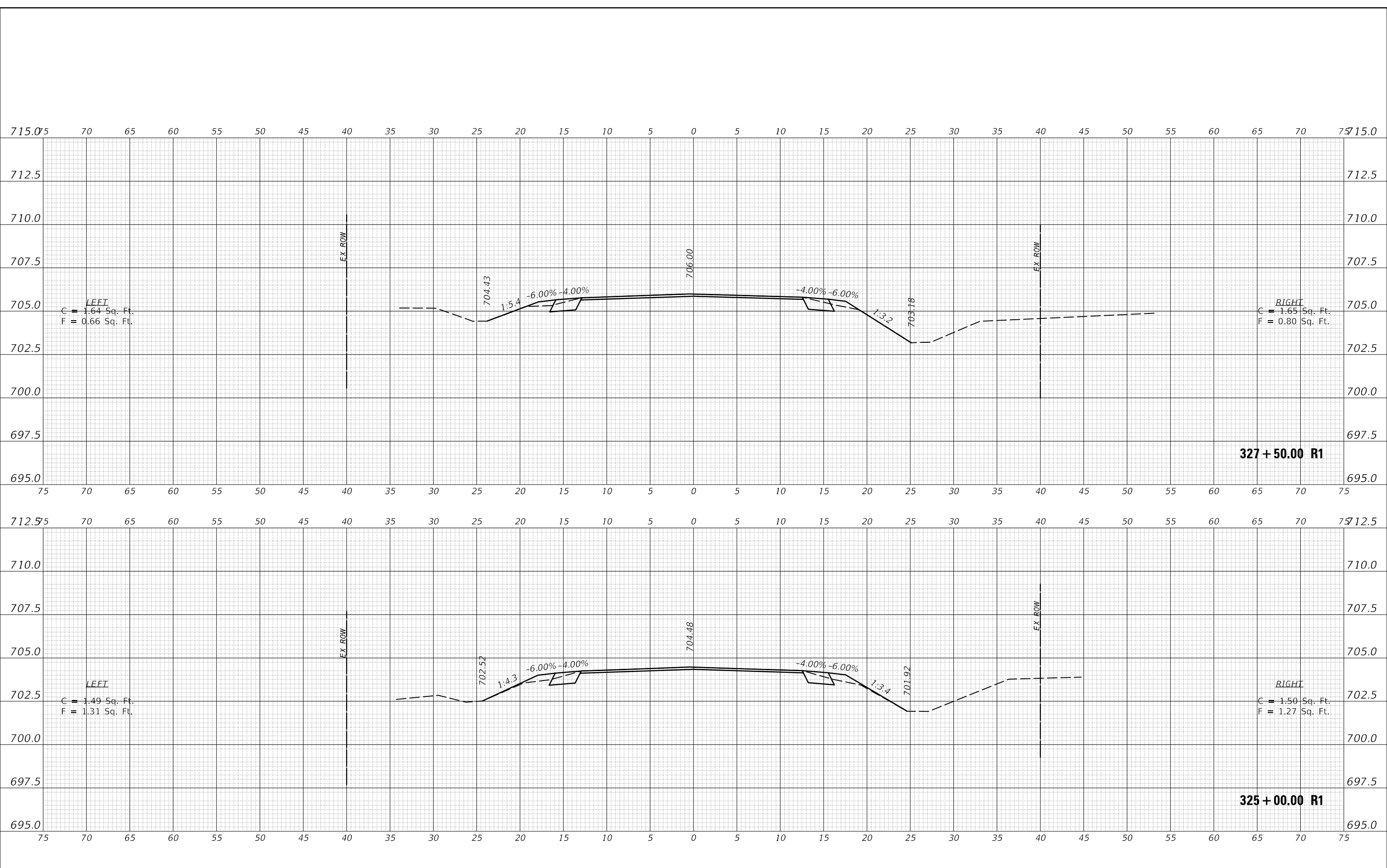

USER NAME = PiersonTJ	DESIGNED -	REVISED -
	DRAWN -	REVISED -
PLOT SCALE = 10.0000' / in.	CHECKED -	REVISED -
PLOT DATE = 3/22/2019	DATE -	REVISED -

**STATE OF ILLINOIS
 DEPARTMENT OF TRANSPORTATION**

IL-49 CROSS-SECTIONS			
SCALE:	SHEET 2	OF 120 SHEETS	STA. 325+00.00 R1 TO STA. 327+50.00 R1

F.A.P. RTE. 836	SECTION **	COUNTY *	TOTAL SHEETS 214	SHEET NO. 93
CONTRACT NO. 70D56				

FINAL SURVEY NO.	SURVEYED	DATE
NOTE BOOK	PLOTTED	
	TEMPLATE	
	AREAS CHECKED	

ORIGINAL SURVEY NO.	SURVEYED	DATE
NOTE BOOK	PLOTTED	
	TEMPLATE	
	AREAS CHECKED	

MODEL: S:\MODEL\NAMES
 FILE NAME: D:\gablenom.d\Illinois\p\PIVOT Documents\DOT Office\District 3\Project\0570D56\CAD\Drawn\Design\0570D56\csh-Cross_Section.dgn

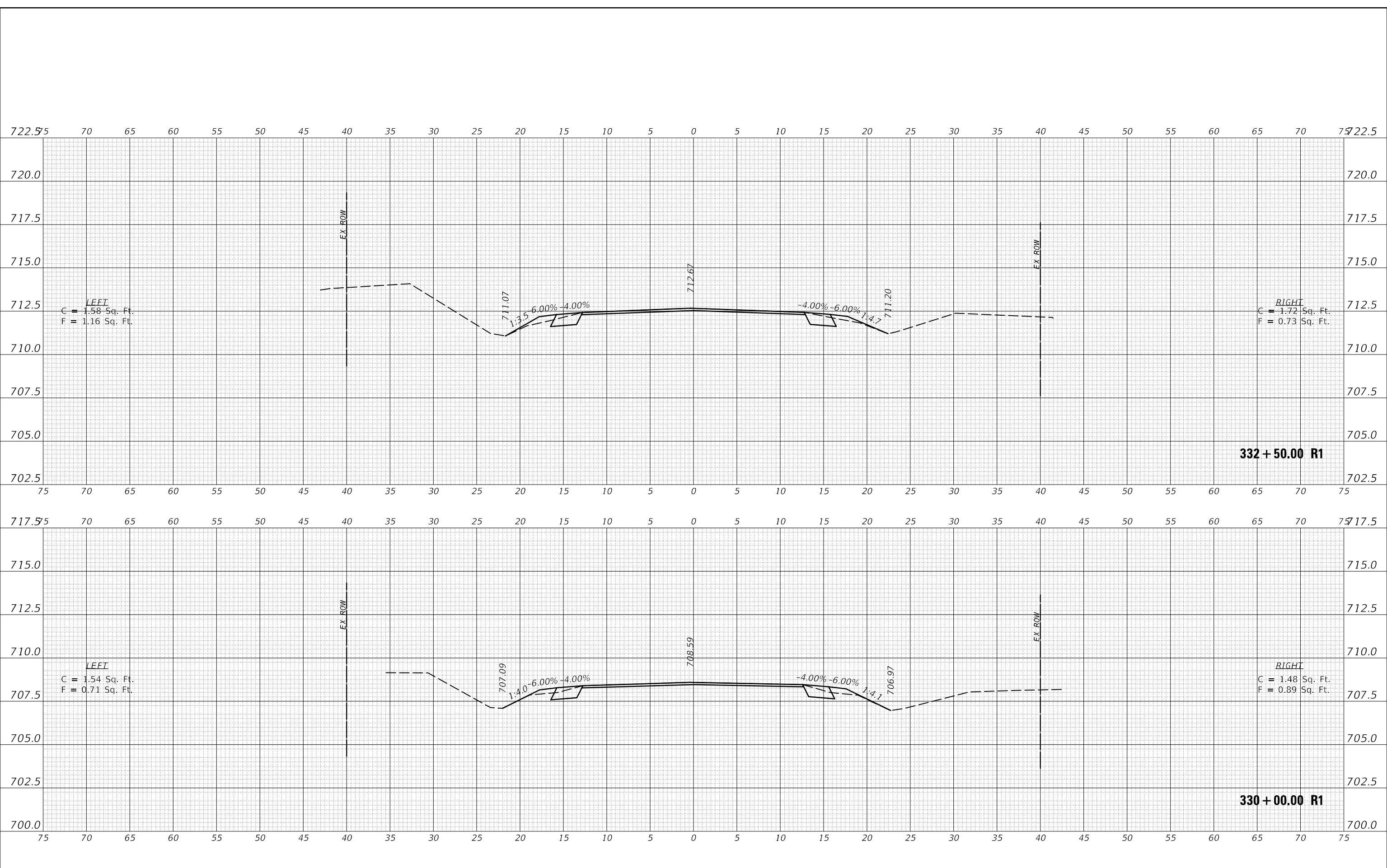

USER NAME = PiersonTJ	DESIGNED -	REVISED -
	DRAWN -	REVISED -
PLOT SCALE = 10.0000' / in.	CHECKED -	REVISED -
PLOT DATE = 3/22/2019	DATE -	REVISED -

**STATE OF ILLINOIS
 DEPARTMENT OF TRANSPORTATION**

IL-49 CROSS-SECTIONS

SCALE: SHEET 3 OF 120 SHEETS STA. 330+00.00 R1 TO STA. 332+50.00 R1

F.A.P. RTE. 836	SECTION **	COUNTY *	TOTAL SHEETS 214	SHEET NO. 94
			CONTRACT NO. 70D56	

DATE	
BY	
FINAL SURVEY	SURVEYED
NOTE BOOK	PLOTTED
NO.	TEMPLATE
	AREAS CHECKED
	AREAS CHECKED

DATE	
BY	
ORIGINAL SURVEY	SURVEYED
NOTE BOOK	PLOTTED
NO.	TEMPLATE
	AREAS CHECKED
	AREAS CHECKED

MODEL: S:\MODEL\NAMES
 FILE NAME: D:\gabriel\mtdm\mtdm\p\WIDOT\Documents\DOT Office\District 3\Project\0570D55\CADD\Drawn\0570D55\csh-Cross Sections.dgn

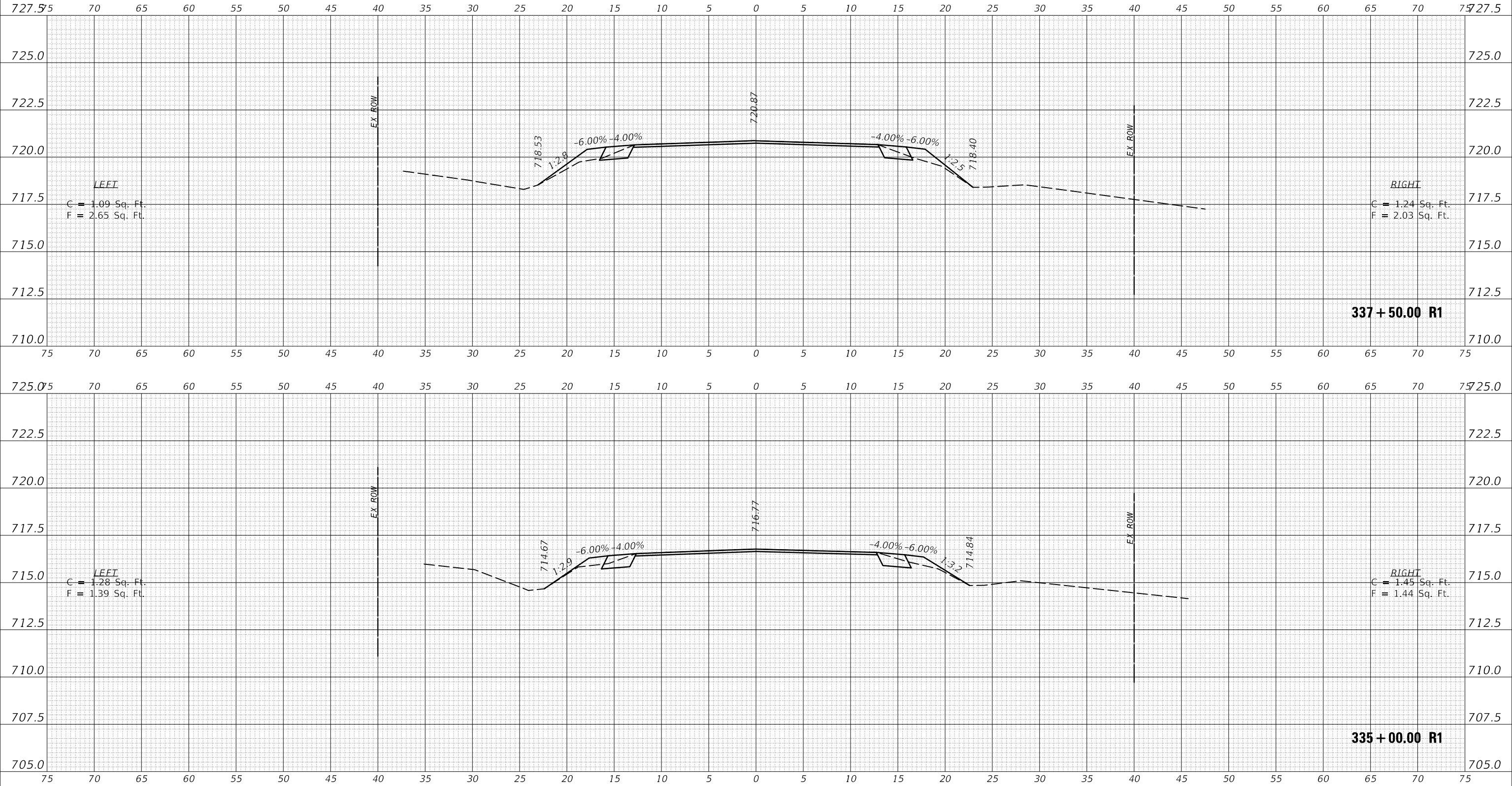

USER NAME = PiersonJ	DESIGNED -	REVISED -
	DRAWN -	REVISED -
PLOT SCALE = 10.0000' / in.	CHECKED -	REVISED -
PLOT DATE = 3/22/2019	DATE -	REVISED -

**STATE OF ILLINOIS
 DEPARTMENT OF TRANSPORTATION**

IL-49 CROSS-SECTIONS	
SCALE:	SHEET 4 OF 120 SHEETS
STA. 335+00.00 R1 TO STA. 337+50.00 R1	

F.A.P. RTE.	SECTION	COUNTY	TOTAL SHEETS	SHEET NO.
836	**	-	214	95
CONTRACT NO. 70D56				

FINAL SURVEY	SURVEYED	DATE
NOTE BOOK	PLOTTED	BY
NO.	TEMPLATE	
	AREAS CHECKED	
	AREAS CHECKED	

ORIGINAL SURVEY	SURVEYED	DATE
NOTE BOOK	PLOTTED	BY
NO.	TEMPLATE	
	AREAS CHECKED	
	AREAS CHECKED	

MODEL: S:\MODEL\NAMES
 FILE NAME: D:\gablencom.d\Illinois\p\PROJECTS\70D56\CADD\Drawn\Design\70D56\secth-Cross_Section.dgn

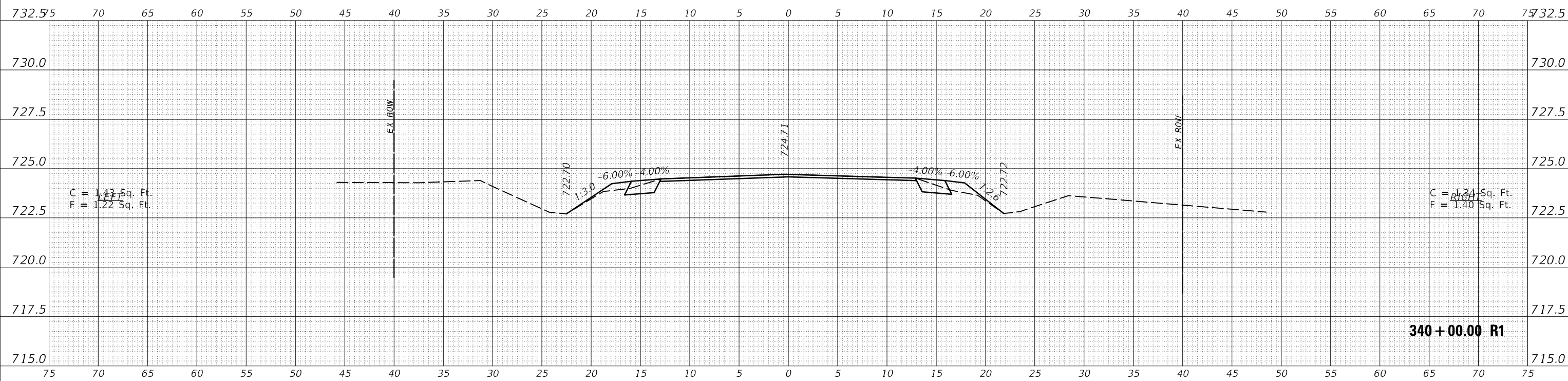
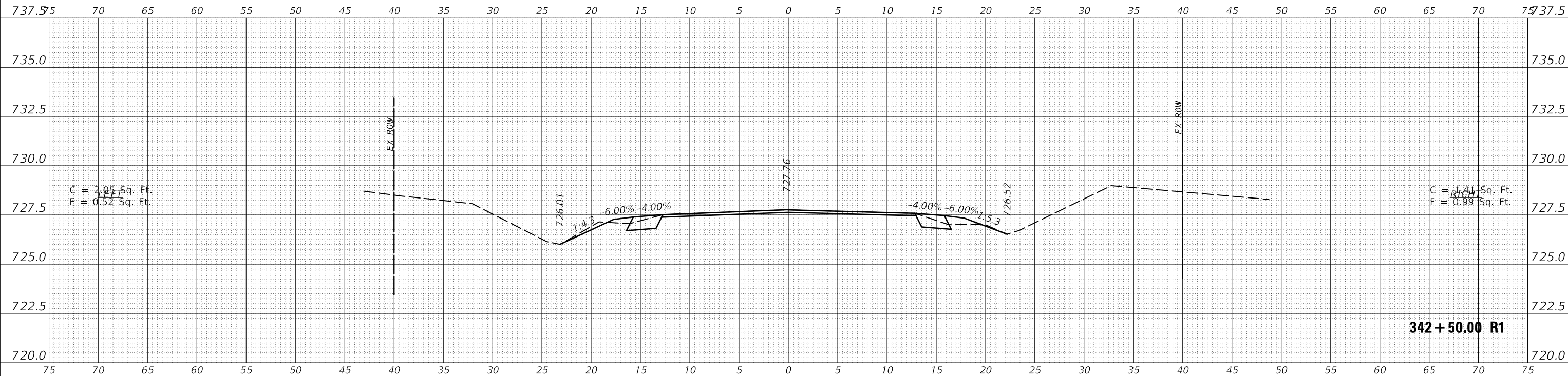

USER NAME = PiersonTJ	DESIGNED -	REVISED -
	DRAWN -	REVISED -
PLOT SCALE = 10.0000' / in.	CHECKED -	REVISED -
PLOT DATE = 3/22/2019	DATE -	REVISED -

STATE OF ILLINOIS
 DEPARTMENT OF TRANSPORTATION

IL-49 CROSS-SECTIONS

SCALE: SHEET 5 OF 120 SHEETS STA. 340+00.00 R1 TO STA. 342+50.00 R1

F.A.P. RTE.	SECTION	COUNTY	TOTAL SHEETS	SHEET NO.
836	**	*	214	96
CONTRACT NO. 70D56				

DATE	
BY	
FINAL SURVEY NO.	
SURVEYED PLOTTED TEMPLATE AREAS CHECKED	
NOTE BOOK NO.	
AREAS CHECKED	

DATE	
BY	
ORIGINAL SURVEY NO.	
SURVEYED PLOTTED TEMPLATE AREAS CHECKED	
NOTE BOOK NO.	
AREAS CHECKED	

MODEL: S:\MODEL\NAMES
FILE NAME: D:\gablan\m.d\Illinois\p\PROJECTS\70D56\CADD\Drawn\Design\70D56\secth-Cross_Section.dgn

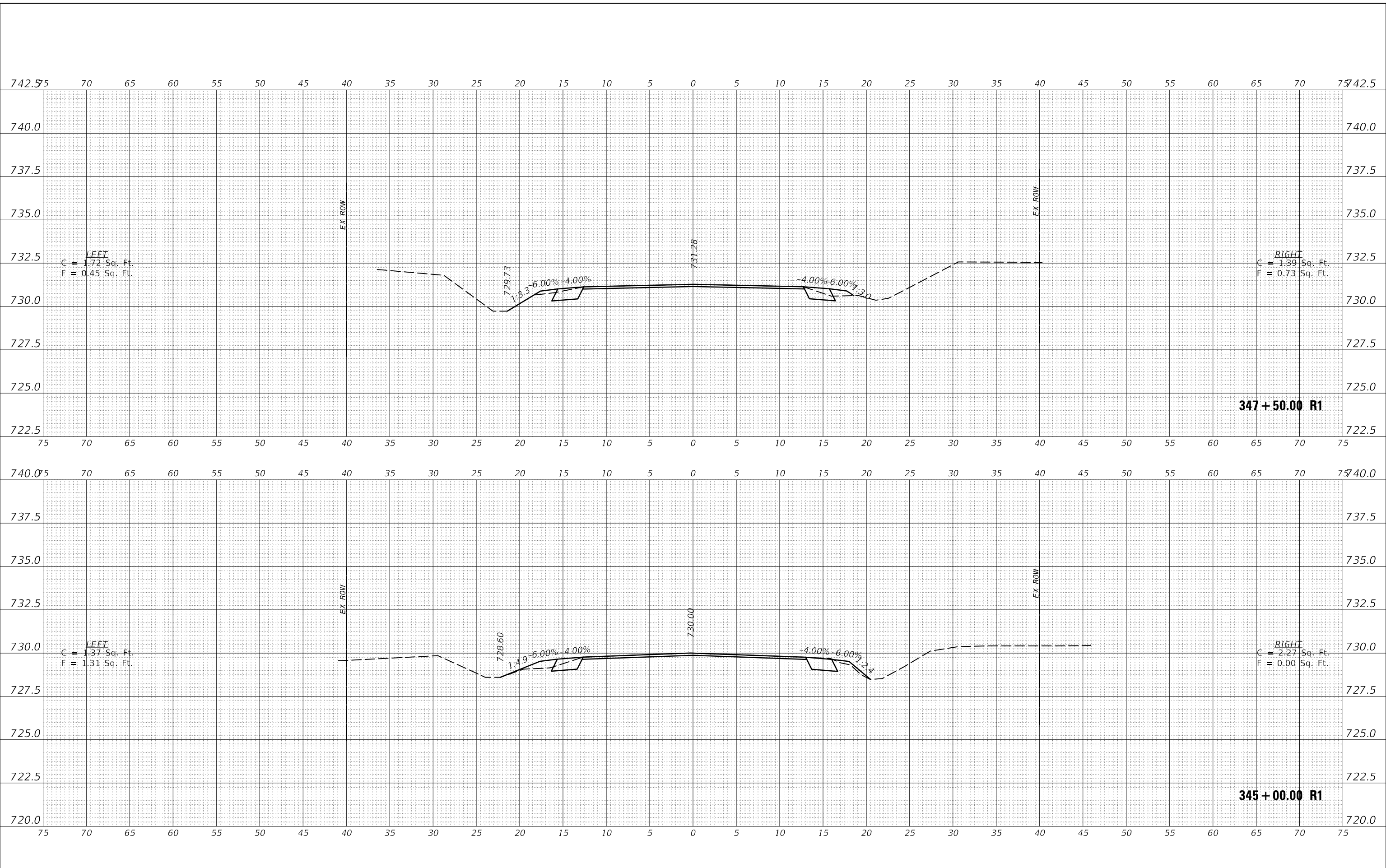

USER NAME = PiersonTJ	DESIGNED -	REVISED -
	DRAWN -	REVISED -
PLOT SCALE = 10.0000 ' / in.	CHECKED -	REVISED -
PLOT DATE = 3/22/2019	DATE -	REVISED -

**STATE OF ILLINOIS
DEPARTMENT OF TRANSPORTATION**

IL-49 CROSS-SECTIONS

SCALE: SHEET 6 OF 120 SHEETS STA. 345+00.00 R1 TO STA. 347+50.00 R1

F.A.P. RTE.	SECTION	COUNTY	TOTAL SHEETS	SHEET NO.
836	**	*	214	97
CONTRACT NO. 70D56				

FINAL SURVEY NO.	SURVEYED PLOTTED AREAS CHECKED	BY	DATE

ORIGINAL SURVEY NO.	SURVEYED PLOTTED AREAS CHECKED	BY	DATE

MODEL: S:\MODEL\NAMES
FILE NAME: D:\gablen\mtda\Illinois\pvt\PIVIDOT\Documents\DOT Office\District 3\Project\ID570D56\CADD\Drawn\ID570D56\sh-Cross Sections.dgn

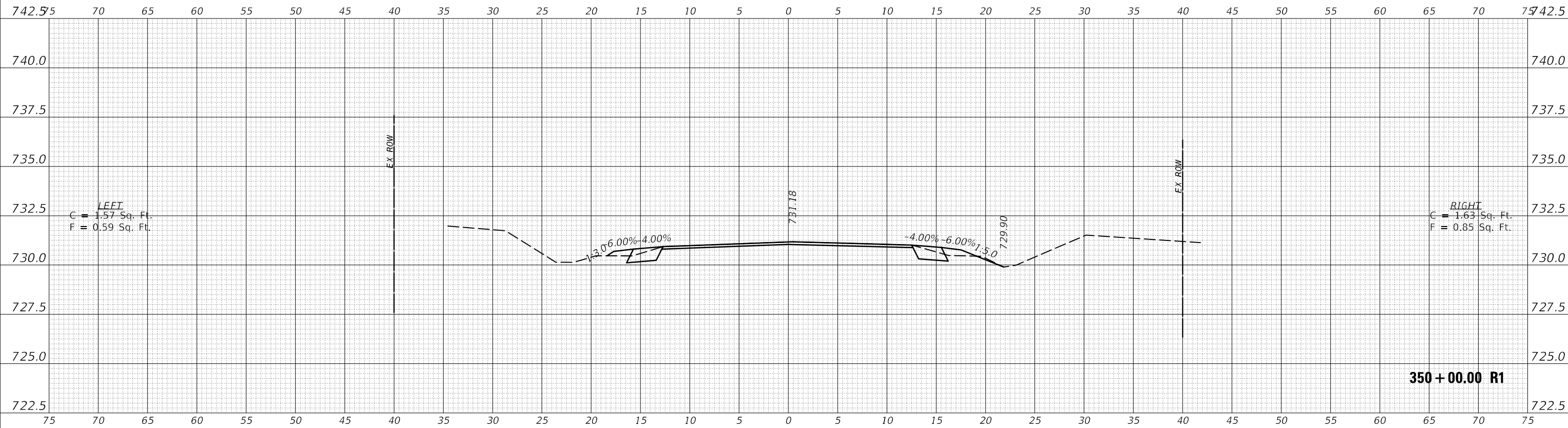

350 + 00.00 R1

USER NAME = PiersonTJ	DESIGNED -	REVISED -
PLOT SCALE = 10.0000 ' / in.	DRAWN -	REVISED -
PLOT DATE = 3/22/2019	CHECKED -	REVISED -
	DATE -	REVISED -

STATE OF ILLINOIS
DEPARTMENT OF TRANSPORTATION

IL-49 CROSS-SECTIONS

SCALE: SHEET 7 OF 120 SHEETS STA. 350+00.00 R1 TO STA. 350+00.00 R1

F.A.P. RTE.	SECTION	COUNTY	TOTAL SHEETS	SHEET NO.
836	**	-	214	98
			CONTRACT NO. 70D56	

DATE	
BY	
FINAL SURVEY	
NOTE BOOK	
NO.	
SURVEYED	
PLOTTED	
TEMPLATE	
AREAS CHECKED	

DATE	
BY	
ORIGINAL SURVEY	
NOTE BOOK	
NO.	
SURVEYED	
PLOTTED	
TEMPLATE	
AREAS CHECKED	

MODEL: \$MODELNAME\$
 FILE NAME: D:\gablancom.d\Illinois\p\PROJECTS\70D56\CADD\Drawings\70D56\5th-Cross Sections.dwg

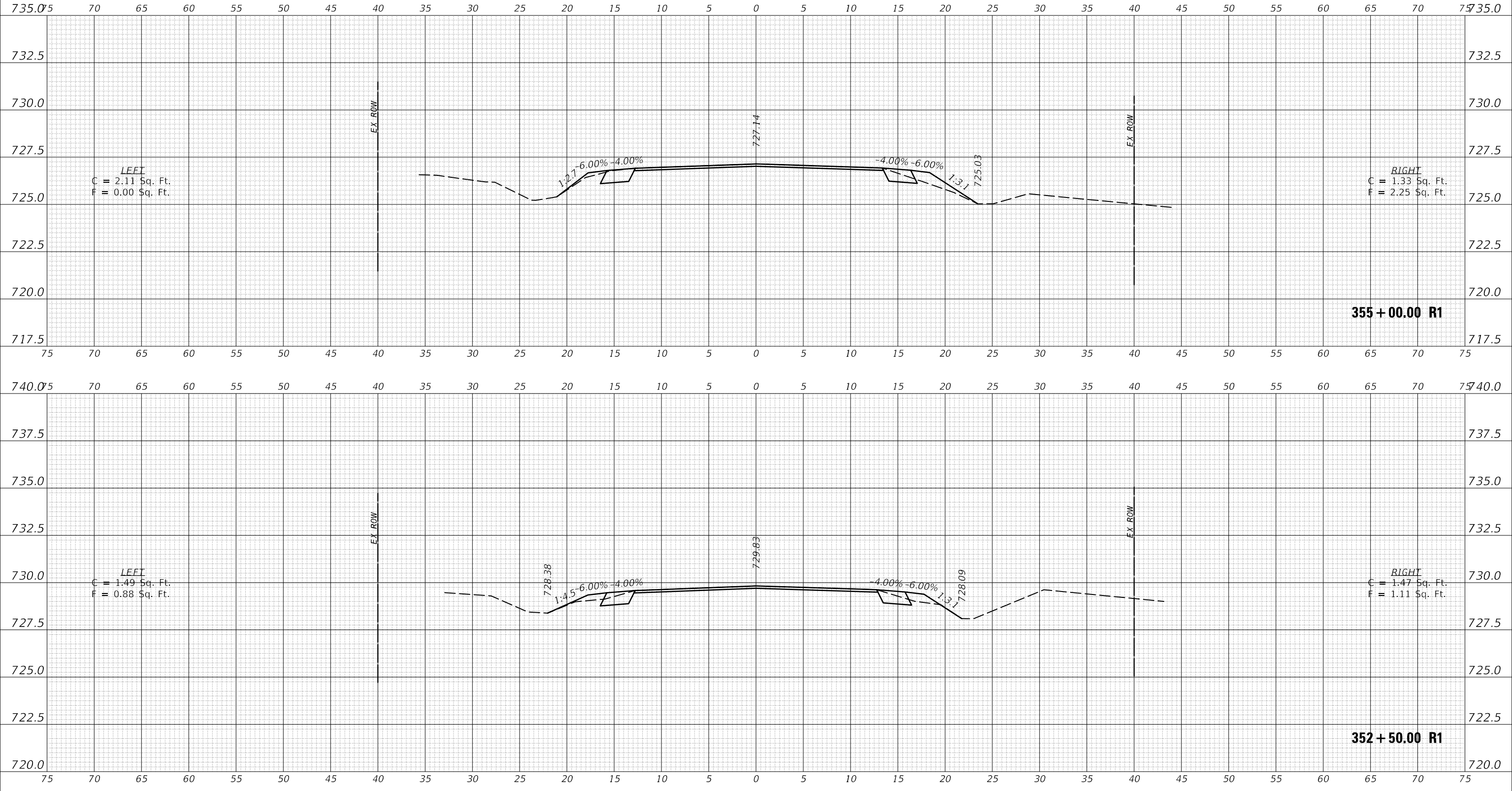

USER NAME = PiersonTJ	DESIGNED -	REVISED -
	DRAWN -	REVISED -
PLOT SCALE = 10.0000 ' / in.	CHECKED -	REVISED -
PLOT DATE = 3/22/2019	DATE -	REVISED -

**STATE OF ILLINOIS
 DEPARTMENT OF TRANSPORTATION**

IL-49 CROSS-SECTIONS

SCALE: SHEET 8 OF 120 SHEETS STA. 352+50.00 R1 TO STA. 355+00.00 R1

F.A.P. RTE.	SECTION	COUNTY	TOTAL SHEETS	SHEET NO.
836	**	*	214	99
			CONTRACT NO. 70D56	

FINAL SURVEY	SURVEYED	DATE
NOTE BOOK	PLOTTED	BY
NO.	TEMPLATE	
	AREAS CHECKED	
	AREAS CHECKED	

ORIGINAL SURVEY	SURVEYED	DATE
NOTE BOOK	PLOTTED	BY
NO.	TEMPLATE	
	AREAS CHECKED	
	AREAS CHECKED	

MODEL: S:\MODEL\NAMES
 FILE NAME: D:\gabrielson\m\illinois\p\70D56\CADD\Drawn\Design\70D56\secth-Cross_Section.dgn

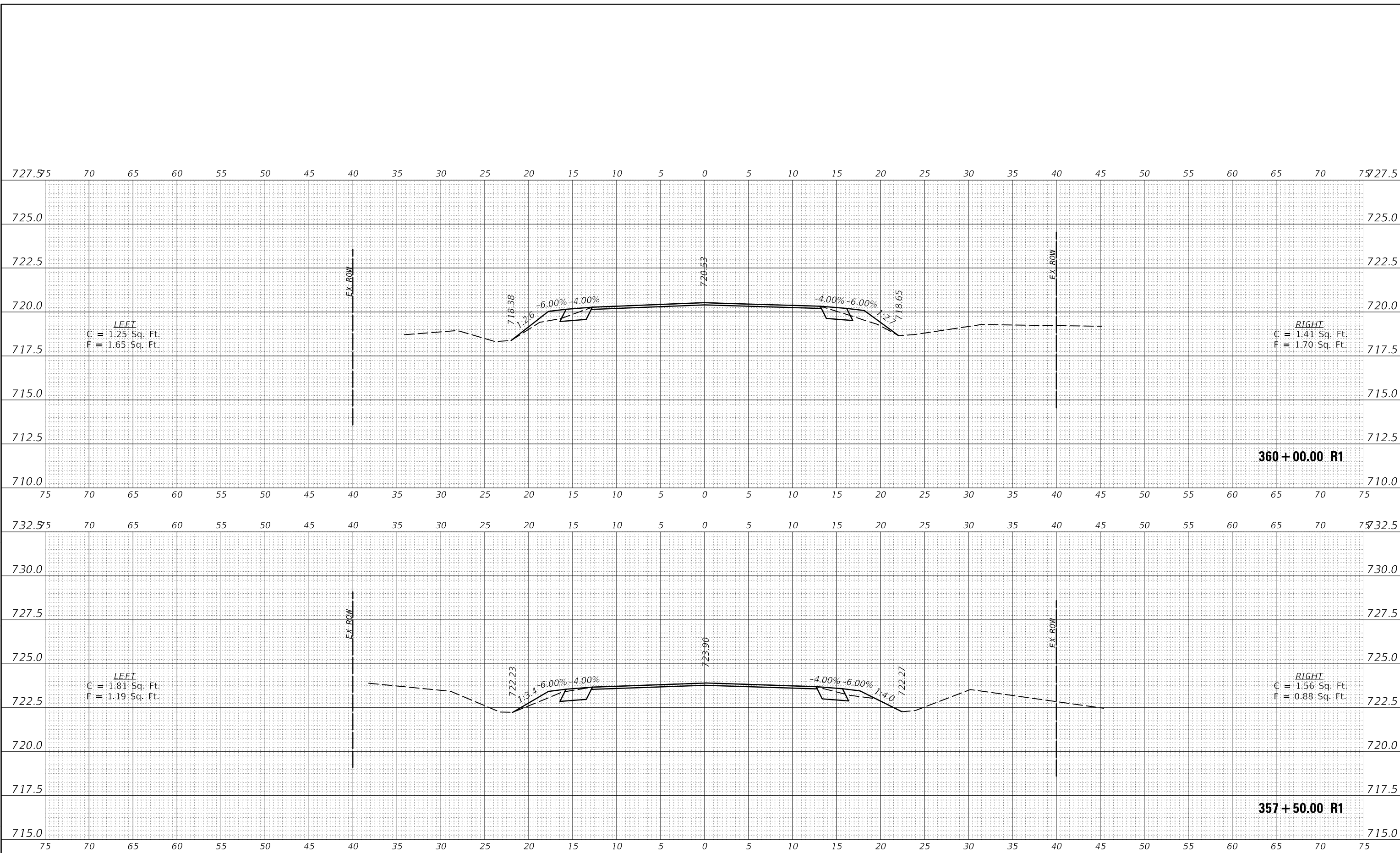

USER NAME = PiersonTJ	DESIGNED -	REVISED -
	DRAWN -	REVISED -
PLOT SCALE = 10.0000 ' / in.	CHECKED -	REVISED -
PLOT DATE = 3/22/2019	DATE -	REVISED -

**STATE OF ILLINOIS
 DEPARTMENT OF TRANSPORTATION**

IL-49 CROSS-SECTIONS

SCALE: SHEET 9 OF 120 SHEETS STA. 357+50.00 R1 TO STA. 360+00.00 R1

F.A.P. RTE.	SECTION	COUNTY	TOTAL SHEETS	SHEET NO.
836	**	*	214	100
			CONTRACT NO. 70D56	