

F.A.P. RTE.	SECTION	COUNTY	TOTAL SHEETS	SHEET NO.
575	14 RS-4	WILL	33	7
STA.		TO STA.		
FED. ROAD DIST. NO.	ILLINOIS	FED. AID PROJECT		

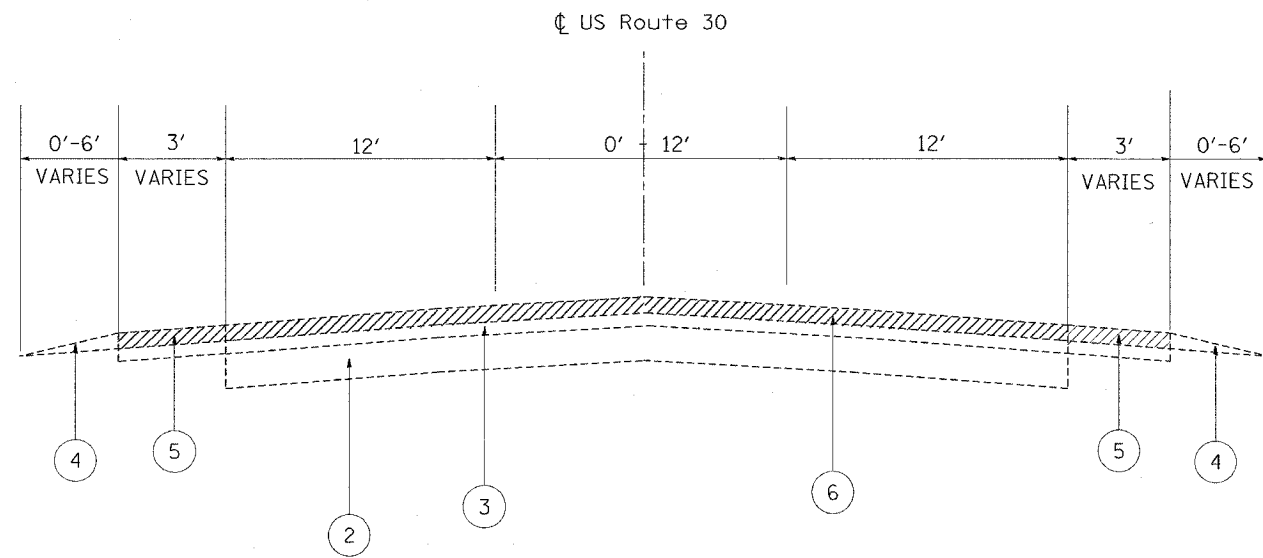

EXISTING TYPICAL SECTION  
 STA. 17+00 TO STA. 79+80  
 STA. 103+97 TO STA. 107+05

LEGEND

- 1 EXISTING B6.12 CURB & GUTTER
- 2 EXISTING P.C.C. BASE COURSE 9" ±
- 3 EXISTING HOT MIX ASPHALT OVERLAY 6" ±
- 4 EXISTING AGGREGATE SHOULDER
- 5 EXISTING HOT-MIX ASPHALT SHOULDERS
- 6 PROPOSED HOT MIX ASPHALT SURFACE REMOVAL 2 1/4"
- 7 PROPOSED POLYMERIZED LEVELING BINDER (MACHINE METHOD), IL-4.75, N50 (3/4")
- 8 PROPOSED POLYMERIZED HOT MIX ASPHALT SURFACE COURSE, MIX "F", N90 (1 3/4")
- 9 PROPOSED GRADING AND SHAPING SHOULDERS
- 10 PROPOSED AGGREGATE WEDGE SHOULDER, TYPE B

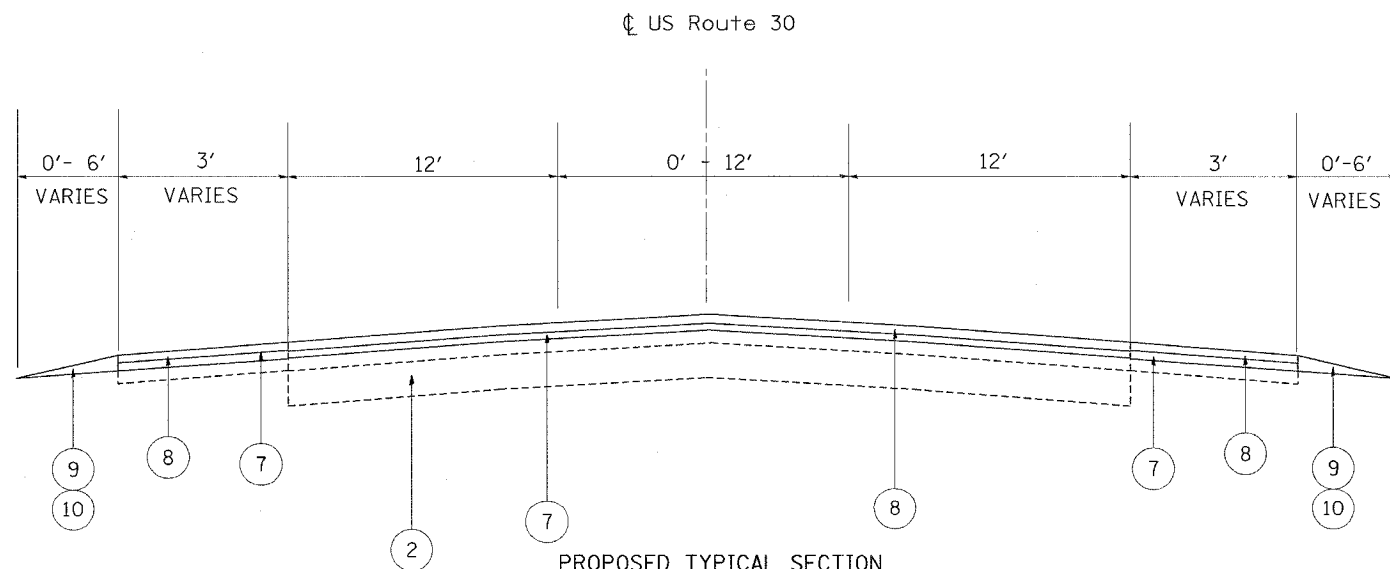

PROPOSED TYPICAL SECTION  
 STA. 17+00 TO STA. 79+80  
 STA. 103+97 TO STA. 107+05

PLOT DATE = 4/2/2007  
 PLOT SCALE = 50.0000' / IN.  
 USER NAME = bmkal

REVISIONS	
NAME	DATE

ILLINOIS DEPARTMENT OF TRANSPORTATION  
**US 30**  
 IL 59 TO W. OF I-55  
 EXISTING AND PROPOSED  
 TYPICAL SECTIONS

SCALE: VERT. \_\_\_\_\_  
 HORIZ. \_\_\_\_\_  
 DATE \_\_\_\_\_

DRAWN BY \_\_\_\_\_  
 CHECKED BY \_\_\_\_\_