

CONTRACT NO. 62896				
F.A.P. RTE.	SECTION	COUNTY	TOTAL SHEETS	SHEET NO.
55	99 (1&2) WRS-1	WILL	227	101
STA.		TO STA.		
FED. ROAD DIST. NO.	ILLINOIS	FED. AID PROJECT		
RSCH 01 OF 01				

SHEET	STATION	OFFSET (FT)	CONCRETE HEADWALL REMOVAL (EACH)	REMOVAL (R)					STORM SEWER TO BE CLEANED (CLN) (FT)	
				MH (EACH)	PRC FES (EACH)	STORM SEWER				
						15"	18"	24"		30"
DRU-03	642+20	CL			1					
DRU-03	642+50	CL					52			
DRU-03	642+67	CL							30" 146	
DRU-03	642+67	100' R							30" 50	
DRU-03	642+75	CL								
DRU-03	642+75	CL		1						
DRU-03	642+75	71' R			1					
DRU-03	643+00	CL						1		
DRU-03	643+03	CL					11			
DRU-05	668+07	CL		1						
DRU-05	668+25	CL							42" 128	
DRU-05	668+25	95' R							42" 40	
DRU-05	668+30	CL					15			
DRU-05	668+40	CL					15			
DRU-05	668+45	CL		1						
DRU-06	683+75	9.5' L	1							
DRU-06	684+00	12' L					115			
DRU-06	684+90	9' L	1							
DRU-06	684+50	68' R							24" 100	
DRU-06	684+50	69' L							18" 105	
DRU-06	693+76	70' L					8			
DRU-06	693+76	77' L			1					
DRU-06	693+76	75.5' R			1					
DRU-06	693+76	CL							24" 159	
DRU-08	726+75	CL					60			
DRU-08	726+75	57' L	1							
DRU-10	751+40	CL						1		
DRU-10	751+60	CL					21			
DRU-10	751+65	4' L		1						
TOTAL			3	4	4	257	40	2	728	



SMITH ENGINEERING CONSULTANTS, INC.
www.smithengineering.com

REVISIONS	
NAME	DATE

ILLINOIS DEPARTMENT OF TRANSPORTATION
FAI ROUTE 55
US 30 (PLAINFIELD ROAD) TO 143RD STREET
DRAINAGE SCHEDULE -
REMOVALS

SCALE: 1" = 50'
DATE: 02/23/2007

DRAWN BY JPA
CHECKED BY TEH

FINAL

F.A.P. RTE.	SECTION	COUNTY	TOTAL SHEETS	SHEET NO.
55	99 (1&2) WRS-1	WILL	227	102
STA.		TO STA.		
FED. ROAD DIST. NO.	ILLINOIS	FED. AID PROJECT		
SSCH 01 OF 02				

STRUCTURE SCHEDULE

STRUCTURE NUMBER	SHEET NUMBER	LOCATION			MANHOLES			REINFORCED CONCRETE PIPE ELBOW, 24"	PRECAST F.E.S.					CATCH BASINS			RIM ELEV	INVERT ELEVATIONS									
					TYPE A									TYPE A													
		STATION	OFFSET (FT)	SIDE	TY 1 F CL				TY 20 F&G	TY 20 F&G	TY 20 F&G	INVERT ELEVATIONS															
					4 FT	5 FT	6 FT					4 FT	5 FT	6 FT	NORTH	SOUTH		EAST	WEST	SOUTH EAST	NORTH EAST	SOUTH WEST	NORTH WEST				
17	DRU 3	642+75	1.5	LT	1										609.81	602.64			602.64	602.57							
18	DRU 3	642+70	1.5	RT											609.91						602.65						
18A	DRU 3	642+75	71.0	RT							1										603.75						
19	DRU 3	645+50	1.5	LT											611.02	604.20		603.95		604.95							
20	DRU 3	645+50	1.5	RT								1			611.07						604.96						
21	DRU 3	648+50	1.5	LT									1		612.06	605.95		605.70		606.45							
22	DRU 3	648+50	1.5	RT									1		612.15						606.46						
23	DRU 3	651+50	1.5	LT										1	613.33	607.94		607.44		607.94							
24	DRU 3	651+50	1.5	RT										1	613.17						607.95						
25	DRU 4	654+50	1.5	LT										1	614.57			609.55		609.55							
26	DRU 4	654+50	1.5	RT										1	614.41						609.56						
27	DRU 4	660+00	1.5	LT										1	614.48				610.99								
28	DRU 4	660+00	1.5	RT										1	614.48	610.48					610.98						
29	DRU 4	661+72	1.5	RT										1	614.25	609.47		609.72									
31	DRU 4	665+46	1.5	RT										1	612.87	607.77		608.27			608.27						
30	DRU 4	665+46	1.5	LT										1	613.03						608.28						
32	DRU 4	666+47.41	1.5	RT										1	612.71	607.55		607.55			608.05						
33	DRU 4	666+47.41	1.5	LT										1	612.74						608.06						
35	DRU 5	667+22.54	1.5	RT										1	612.63	607.26		607.26			607.76						
34	DRU 5	667+22.54	1.5	LT										1	612.63						607.77						
37	DRU 5	668+00	1.5	RT										1	612.55	606.62		606.87			607.48						
36	DRU 5	668+00	1.5	LT										1	612.43						607.49						
38	DRU 5	668+28	1.5	RT			1							1	612.60	605.67		605.67									
39	DRU 5	669+11.31	1.5	RT										1	612.34	606.26		606.26			606.76						
40	DRU 5	669+11.31	1.5	LT										1	612.20						606.77						
42	DRU 5	669+90.94	1.5	RT										1	612.27	606.34		606.34			606.84						
41	DRU 5	669+91.12	1.5	LT										1	612.10						606.85						
44	DRU 5	670+74.74	1.5	RT										1	612.15	606.43		606.43			606.93						
43	DRU 5	670+74.76	1.5	LT										1	612.11						606.94						
46	DRU 5	671+31.84	1.5	RT										1	612.11	606.49		606.49			606.99						
45	DRU 5	671+31.84	1.5	LT										1	612.14						607.00						
48	DRU 5	672+14.68	1.5	RT										1	612.09	606.58		606.58			607.08						
47	DRU 5	672+14.68	1.5	LT										1	612.26						607.09						
50	DRU 5	672+84.91	1.5	RT										1	612.07	606.65		606.65			607.15						
49	DRU 5	672+84.12	1.5	LT										1	612.24						607.16						
52	DRU 5	673+57.54	1.5	RT										1	612.12	606.72		606.72			607.22						
51	DRU 5	673+57.56	1.5	LT										1	612.28						607.23						
54	DRU 5	674+52.96	1.5	RT										1	612.37	606.87		606.87			607.37						
53	DRU 5	674+52.96	1.5	LT										1	612.39						607.38						
56	DRU 5	675+43.69	1.5	RT										1	612.58	607.08		607.08			607.58						
55	DRU 5	675+43.69	1.5	LT										1	612.51						607.59						
58	DRU 5	677+00	1.5	RT										1	612.93	607.42		607.42			607.92						
57	DRU 5	677+00	1.5	LT										1	612.95						607.93						
60	DRU 5	679+00	1.5	RT										1	613.59	608.34		608.13			608.63						
59	DRU 5	679+00	1.5	LT										1	613.69						608.64						
62	DRU 5	682+00	1.5	RT										1	614.56	609.56		609.49			609.99						
61	DRU 5	682+00	1.5	LT										1	614.67						610.00						
63	DRU 6	683+50	1.5	RT			1							1	615.43	610.06		610.05									
64	DRU 6	683+67	5.0	RT			1							1	615.67	610.13		610.12									
65	DRU 6	684+69	5.0	RT			1							1	615.97	610.46		610.46									
66	DRU 6	685+00	1.5	RT										1	615.57	610.80		610.55			611.05						
67	DRU 6	685+00	1.5	LT										1	615.59				611.06								
68	DRU 6	688+00	1.5	RT										1	616.67	612.42		611.92			612.42						
69	DRU 6	688+00	1.5	LT										1	616.98						612.43						
70	DRU 6	691+00	1.5	RT										1	617.76			613.51			614.01						
71	DRU 6	691+00	1.5	LT										1	617.88						614.02						
72	DRU 6	693+76	1.5	LT	1									1	618.81	612.58					612.58						
73	DRU 6	693+76	76.0	LT					1												612.59						
74	DRU 6	693+76	74.0	RT					1																		
75	DRU 6	694+00	1.5	LT										1	618.90	612.68		612.68			612.93						
76	DRU 6	694+00	1.5	RT										1	618.88						612.94						
77	DRU 6	696+50	1.5	LT										1	620.96	616.03		615.78			616.03						
78	DRU 6	696+50	1.5	RT										1	620.96						616.04						
79	DRU 7	699+50	1.5	LT										1	624.70												



SMITH ENGINEERING CONSULTANTS, INC. www.smithengineering.com

REVISIONS	NAME	DATE

ILLINOIS DEPARTMENT OF TRANSPORTATION
 I-55 (PLAINFIELD ROAD) TO 143RD STREET
 DRAINAGE SCHEDULE - STRUCTURES
 (1 OF 2)
 SCALE: 1" = 50'
 DATE: 02/23/2007
 DRAWN BY: JPA
 CHECKED BY: TEH

STRUCTURE SCHEDULE

F.A.P. RTE.	SECTION	COUNTY	TOTAL SHEETS	SHEET NO.
55	99 (1&2) WRS-1	WILL	227	103
STA.	TO STA.			
FED. ROAD DIST. NO.	ILLINOIS	FED. AID PROJECT	SSCH 02 OF 02	

STRUCTURE NUMBER	SHEET NUMBER	LOCATION			MANHOLES			REINFORCED CONCRETE PIPE ELBOW, 24"	PRECAST F.E.S.					CATCH BASINS			RIM ELEV	INVERT ELEVATIONS																			
		STATION	OFFSET (FT)	SIDE	TYPE A				TYPE A					TY 20 F&G	TY 20 F&G	TY 20 F&G		4 FT	5 FT	6 FT	4 FT	5 FT	6 FT														
					TY 1 F CL																																
					4 FT	5 FT	6 FT		24"	24"	27"	30"	36"											4 FT	5 FT	6 FT	NORTH	SOUTH	EAST	WEST	SOUTH EAST	NORTH EAST	SOUTH WEST	NORTH WEST			
80	DRU 7	699+50	1.5	RT											1			624.60																			
81	DRU 8	723+50	1.5	LT											1			622.05	618.55			618.55															
82	DRU 8	723+50	1.5	RT											1			622.10				618.56															
83	DRU 8	726+00	1.5	LT											1			620.71	617.47	617.47		617.47															
84	DRU 8	726+00	1.5	RT											1			620.72				617.48															
85	DRU 8	726+50	1.5	LT											1			620.68	617.31	617.31		617.31															
86	DRU 8	726+50	1.5	RT											1			620.67				617.32															
87	DRU 8	726+75	1.5	RT											1			620.65	616.48			616.48															
88	DRU 8	726+75	62.5	LT					1								618.39				616.39																
89	DRU 8	726+75	1.5	LT											1			620.63	616.45	617.23		616.45	616.45														
90	DRU 9	728+00	1.5	LT											1			620.84	616.58	616.58																	
91	DRU 9	728+00	1.5	RT											1			620.76	616.60	616.60																	
93	DRU 9	730+33.19	1.5	RT											1			621.34	617.10	617.10																	
92	DRU 9	730+50	1.5	LT											1			621.52	616.84	616.84																	
94	DRU 9	733+50	1.5	LT											1			622.65	617.95	617.95																	
95	DRU 9	733+50	1.5	RT											1			622.63	617.17	617.17																	
97	DRU 9	736+50	1.5	RT											1			623.45	619.16	619.16																	
96	DRU 9	736+50	1.5	LT											1			623.48	618.35	618.10																	
99	DRU 9	738+16	1.5	RT											1			623.88		619.88																	
98	DRU 9	738+16	1.5	LT											1			623.86		619.06																	
100	DRU 10	743+00	1.5	LT											1			623.50	619.40																		
101	DRU 10	743+00	1.5	RT											1			623.48	619.47																		
102	DRU 10	746+00	1.5	LT											1			622.11	618.05	618.05																	
103	DRU 10	746+00	1.5	RT											1			622.05	618.02	618.02																	
104	DRU 10	749+00	1.5	LT											1			620.47	616.10	616.35																	
105	DRU 10	749+00	1.5	RT											1			620.58	615.86	616.46																	
TOTALS									1	1	1							3	3																		



REVISIONS	
NAME	DATE

ILLINOIS DEPARTMENT OF TRANSPORTATION

FAI ROUTE 55
US 30 (PLAINFIELD ROAD) TO 143RD STREET

DRAINAGE SCHEDULE -
STRUCTURES
(2 OF 2)

SCALE: 1" = 50'
DATE: 02/23/2007

DRAWN BY: JPA
CHECKED BY: TEH

F.A.P. RTE.	SECTION	COUNTY	TOTAL SHEETS	SHEET NO.
55	99 (1&2) WRS-1	WILL.	227	104
STA.		TO STA.		
FED. ROAD DIST. NO.		ILLINOIS	FED. AID PROJECT	
USCH 01 OF 01				

PIPE UNDERDRAIN SCHEDULE

STATION	TO STATION	OFFSET (FT)	PIPE UNDERDRAINS 6" (FT)	PIPE UNDERDRAINS (SPECIAL) 6" (FT)
641+00	642+73	RT	173	
641+00	642+73	LT	173	
642+73	642+75	RT		4
642+73	642+75	LT		4
642+75	645+48	RT	273	
642+75	645+48	LT	273	
645+48	645+50	RT		4
645+48	645+50	LT		4
645+50	648+48	RT	298	
645+50	648+48	LT	298	
648+48	648+50	RT		4
648+48	648+50	LT		4
648+50	651+48	RT	298	
648+50	651+48	LT	298	
651+48	651+50	RT		4
651+48	651+50	LT		4
651+50	654+48	RT	298	
651+50	654+48	LT	298	
654+48	654+50	RT		4
654+48	654+50	LT		4
660+02	660+00	RT		4
660+02	660+00	LT		4
660+00	661+70	RT	170	
661+70	661+72	RT		4
661+72	665+44	RT	372	
660+00	665+44	LT	544	
665+44	665+46	RT		4
665+44	665+46	LT		4
665+46	666+45	RT	99	
665+46	666+45	LT	99	
666+45	666+47	RT		4
666+45	666+47	LT		4
666+47	667+21	RT	74	
666+47	667+21	LT	74	
667+21	667+23	RT		4
667+21	667+23	LT		4
667+23	667+98	RT	75	
667+23	667+98	LT	75	
667+98	668+00	RT		4
667+98	668+00	LT		4
668+00	669+09	RT	109	
668+00	669+09	LT	109	
669+09	669+11	RT		4
669+09	669+11	LT		4
669+11	669+89	RT	78	
669+11	669+89	LT	78	
669+89	669+91	RT		4
669+89	669+91	LT		4
669+91	670+73	RT	82	
669+91	670+73	LT	82	
670+73	670+75	RT		4
670+73	670+75	LT		4
670+75	671+30	RT	55	
670+75	671+30	LT	55	
671+30	671+32	RT		4
671+30	671+32	LT		4
671+32	672+13	RT	81	
671+32	672+13	LT	81	
672+13	672+15	RT		4
672+13	672+15	LT		4
672+15	672+83	RT	68	
672+15	672+83	LT	68	
672+83	672+85	RT		4
672+83	672+85	LT		4
672+85	673+56	RT	71	
672+85	673+56	LT	71	
673+56	673+58	RT		4
673+56	673+58	LT		4
673+58	674+51	RT	93	
673+58	674+51	LT	93	
674+51	674+53	RT		4
674+51	674+53	LT		4
674+53	675+42	RT	89	
674+53	675+42	LT	89	
675+42	675+44	RT		4
675+42	675+44	LT		4

PIPE UNDERDRAIN SCHEDULE

STATION	TO STATION	OFFSET (FT)	PIPE UNDERDRAINS 6" (FT)	PIPE UNDERDRAINS (SPECIAL) 6" (FT)
675+44	676+98	RT	154	
675+44	676+98	LT	154	
676+98	677+00	RT		4
676+98	677+00	LT		4
677+00	678+98	RT	198	
677+00	678+98	LT	198	
678+98	679+00	RT		4
678+98	679+00	LT		4
679+00	681+98	RT	298	
679+00	681+98	LT	298	
681+98	682+00	RT		4
681+98	682+00	LT		4
682+00	684+98	RT	298	
682+00	684+98	LT	298	
684+98	685+00	RT		4
684+98	685+00	LT		4
685+00	687+98	RT	298	
685+00	687+98	LT	298	
687+98	688+00	RT		4
687+98	688+00	LT		4
688+00	690+98	RT	298	
688+00	690+98	LT	298	
690+98	691+00	RT		4
690+98	691+00	LT		4
691+00	693+78	RT	278	
691+00	693+78	LT	278	
693+78	693+80	RT		4
693+78	693+80	LT		4
693+80	696+48	RT	268	
693+80	696+48	LT	268	
696+48	696+50	RT		4
696+48	696+50	LT		4
696+50	699+48	RT	298	
696+50	699+48	LT	298	
699+48	699+50	RT		4
699+48	699+50	LT		4
699+50	700+05	RT	55	
699+50	700+05	LT	55	
722+50	725+98	RT	350	
722+50	725+98	LT	350	
725+98	726+00	RT		4
725+98	726+00	LT		4
726+00	726+73	RT	75	
726+00	726+73	LT	75	
726+73	726+75	RT		4
726+73	726+75	LT		4
726+75	727+98	RT	123	
726+75	727+98	LT	123	
727+98	728+00	RT		4
727+98	728+00	LT		4
728+00	730+31	RT	231	
728+00	730+48	LT	248	
730+31	730+33	RT		4
730+48	730+50	LT		4
730+33	733+48	RT	315	
730+50	733+48	LT	298	
733+48	733+50	RT		4
733+48	733+50	LT		4
733+50	736+48	RT	298	
733+50	736+48	LT	298	
736+48	736+50	RT		4
736+48	736+50	LT		4
736+50	738+14	RT	164	
736+50	738+14	LT	164	
738+14	738+16	RT		4
738+14	738+16	LT		4
743+00	745+98	RT	298	
743+00	745+98	LT	298	
745+98	746+00	RT		4
745+98	746+00	LT		4
746+00	748+98	RT	298	
746+00	748+98	LT	298	
748+98	749+00	RT		4
748+98	749+00	LT		4
749+00	751+75	RT	275	
749+00	751+75	LT	275	
TOTALS			15454	300



REVISIONS	
NAME	DATE

ILLINOIS DEPARTMENT OF TRANSPORTATION
 FAI ROUTE 55
 US 30 (PLAINFIELD ROAD) TO 143RD STREET
**DRAINAGE SCHEDULE -
 PIPE UNDERDRAIN**
 SCALE: 1" = 50'
 DATE: 02/23/2007
 DRAWN BY JPA
 CHECKED BY TEH

F.A.I. RTE.	SECTION	COUNTY	TOTAL SHEETS	SHEET NO.
55	99 (1&2) WRS-1	WILL	227	105
STA.			TO STA.	
FED. ROAD DIST. NO.			ILLINOIS FED. AID PROJECT	

CONTRACT NO.	SHEET NO.
60383	1

TEST HOLE #	SIZE & TYPE	NORTHING	EASTING	OFFSET	TOP OF UTILITY	EXISTING CUT	REFERENCE GROUND ELEVATION	COMMENTS
1	36" G	1761977.91	1021140.02	30.97' LT	588.40'	5.78'	594.15'	SUE QUALITY LEVEL "A"
2	36" G	1761442.74	1021158.57	28.65' LT	589.76'	7.80'	591.56'	SUE QUALITY LEVEL "A"
3	24" G	1761342.59	1021165.10	25.29' LT	585.29'	5.77'	591.06'	SUE QUALITY LEVEL "A"
4	36" G	1761311.69	1021168.82	22.55' LT	584.45'	6.60'	591.05'	SUE QUALITY LEVEL "A"
5	30" G	1761217.69	1021170.05	24.24' LT	583.81'	6.03'	589.84'	SUE QUALITY LEVEL "A"
6	36" G	1760961.17	1021177.66	24.58' LT	581.10'	6.45'	587.56'	SUE QUALITY LEVEL "A"
7	36" G	1760960.02	1021451.05	28.96' RT	581.72'	5.45'	587.17'	SUE QUALITY LEVEL "A"
8	36" G	1761476.94	1021438.16	32.12' RT	588.56'	3.80'	592.30'	SUE QUALITY LEVEL "A"
9	30" G	1761502.81	1021498.60	93.34' RT	587.35'	6.32'	593.67'	SUE QUALITY LEVEL "A"
10	36" G	1761565.03	1021437.19	33.89' RT	586.18'	6.56'	592.74'	SUE QUALITY LEVEL "A"
11	24" G	1761620.42	1021437.02	35.44' RT	587.24'	6.48'	593.72'	SUE QUALITY LEVEL "A"
12	36" G	1761724.77	1021430.72	32.38' RT	585.79'	7.79'	593.57'	SUE QUALITY LEVEL "A"
13	36" G	1762033.48	1021427.22	35.74' RT	582.33'	11.82'	594.15'	SUE QUALITY LEVEL "A"
14	36" G	1764930.49	1021304.11	76.43' RT	576.82'	7.58'	584.20'	SUE QUALITY LEVEL "A"
15	36" G	1764892.83	1021316.93	88.20' RT	575.86'	9.18'	585.04'	SUE QUALITY LEVEL "A"
16	20" G	1764947.85	1021327.45	83.64' RT	583.13'	6.03'	589.16'	SUE QUALITY LEVEL "A"
17	42" G	1764997.02	1021191.01	34.73' LT	575.87'	7.42'	583.29'	SUE QUALITY LEVEL "A"
18	40" G	1764968.48	1021190.20	36.39' LT	578.66'	4.85'	583.51'	SUE QUALITY LEVEL "A"
19	24" G	1764412.46	1021208.28	33.70' LT	581.30'	5.83'	587.13'	SUE QUALITY LEVEL "A"
20	36" G	1761923.14	1020284.46	88.41' LT	587.94'	4.36'	592.30'	SUE QUALITY LEVEL "A"
21	36" G	1761113.92	1020837.27	358.93' LT	585.00'	3.99'	588.99'	SUE QUALITY LEVEL "A"
22	24" G	1761070.06	1020865.93	331.66' LT	584.19'	4.36'	588.55'	SUE QUALITY LEVEL "A"
23	36" G	1761033.53	1020896.84	301.92' LT	584.14'	4.01'	588.15'	SUE QUALITY LEVEL "A"
24	30" G	1760973.03	1020934.20	286.48' LT	583.97'	4.14'	588.11'	SUE QUALITY LEVEL "A"
25	36" G	1760931.81	1020970.94	231.05' LT	584.58'	3.48'	588.06'	SUE QUALITY LEVEL "A"
26	SEE NOTE	1761588.07	1021554.22	152.28' RT	590.54'	3.36'	593.90'	SUE QUALITY LEVEL "A"
27	30" G	1761607.88	1021535.48	135.12' RT	590.48'	4.26'	594.74'	SUE QUALITY LEVEL "A"
28	SEE NOTE	1761643.16	1021517.84	118.60' RT	586.00'	9.44'	595.44'	SUE QUALITY LEVEL "A"
29	24" G	1761708.92	1021492.06	94.90' RT	590.37'	4.88'	595.23'	SUE QUALITY LEVEL "A"
30	SEE NOTE	1761763.53	1021469.32	73.89' RT	586.90'	8.79'	595.69'	SUE QUALITY LEVEL "A"

TEST HOLE #	SIZE & TYPE	NORTHING	EASTING	EXISTING TOP ELEVATION	EXISTING CUT ELEVATION	REFERENCE ELEVATION	COMMENTS

NOTES
 TH#17, 18 & 19 According to record drawings, the gas main under College St. is placed in a casing.
 TH#26 Unable to expose utility due to water, but were able to probe to feel utility.
 TH#28 Unable to expose utility due to mud and water, but were able to probe to feel utility.
 TH#30 Unable to expose utility due to hard clay, but were able to probe to feel utility.

ALL INFORMATION SHOWN WAS OBTAINED FROM A LOCATION SURVEY. OFFSETS AND STATIONS ARE IN RELATION TO THE BASELINE OF SURVEY.

Illinois Department of Transportation
 RT-59 / RT-52
 Contract Number: 60383
 Work Order No. 132,142,158,229
 Shorewood, IL (Will County)
 TBE Project No.: IL09500132, 142, 158, 229

DATE	BY	DESCRIPTION	DATE	BY	DESCRIPTION	DATE	BY	DESCRIPTION	DATE	BY	DESCRIPTION	DATE	BY	DESCRIPTION	DATE	BY	DESCRIPTION
10/20/07	JS																

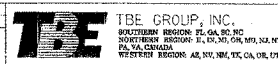

VERIFIED UTILITY LOCATIONS



ILLINOIS DEPARTMENT OF TRANSPORTATION
 FAI ROUTE 55
 US 30 (PLAINFIELD ROAD) TO 143RD STREET
 SUE Investigation of Underground Utilities
 1-55/1-80 from US RT. 30 to Weber Road
 Section No. 99 (1&2) WRS-1
 Contract No. 62895 and 62896
 Will County

SCALE: NONE
 DATE: 02-23-07
 DRAWN BY: DM
 CHECKED BY: DVS

F.A.I. RTE.	SECTION	COUNTY	TOTAL SHEETS	SHEET NO.
55	99 (1&2) WRS-1	Will	227	105A
STA.		TO STA.		
FED. ROAD DIST. NO.		ILLINOIS	FED. AID PROJECT	

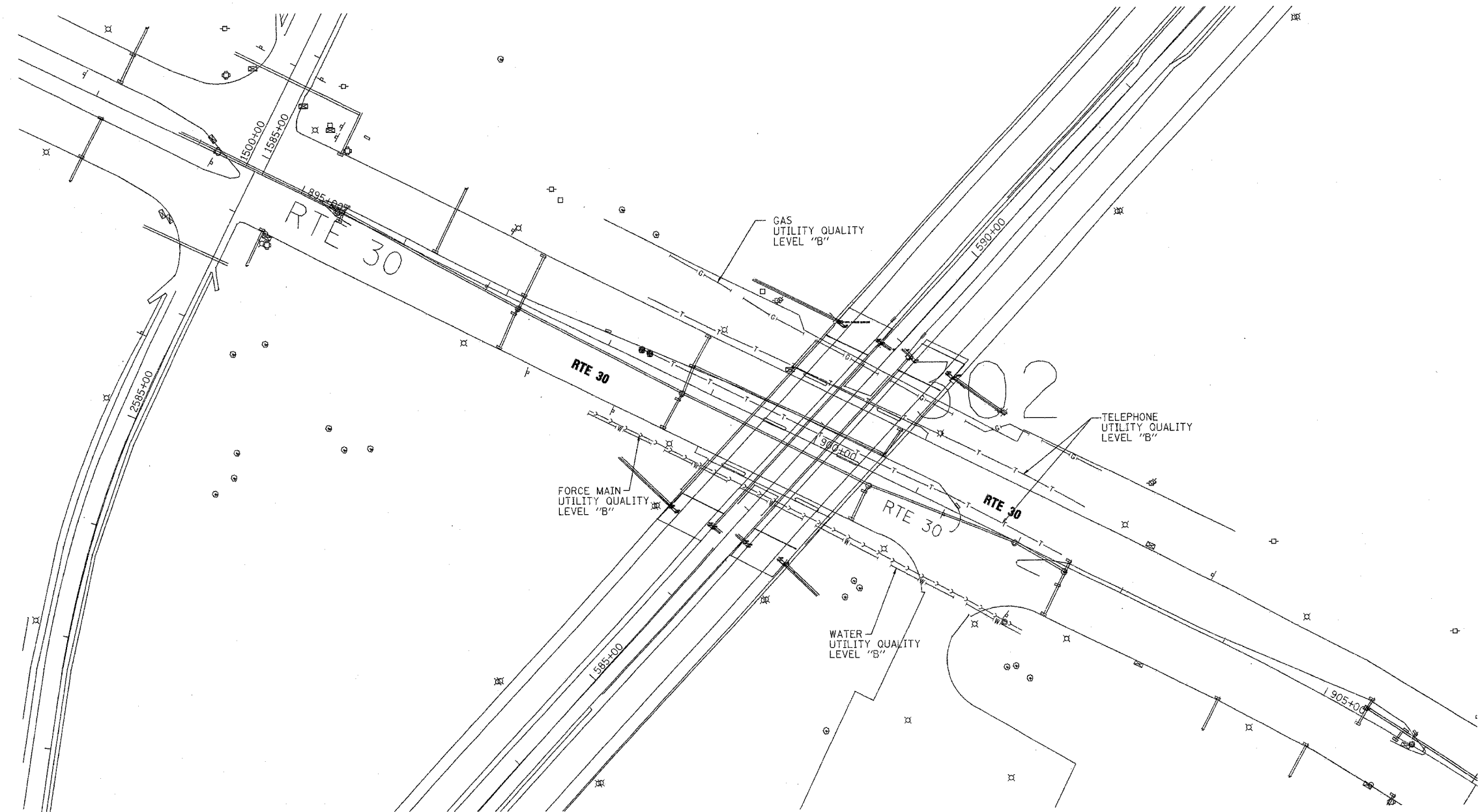

The SBC locations depicted have been obtained through the application of geophysical methods to determine the existence and approximate horizontal position of these facilities. However, SBC will not provide TBE Group, Inc. with utility records nor allow access to their field closures (pedestals/manholes etc.), to help verify the locations of their existing underground facilities. Therefore, TBE is unable to verify the completeness of the SBC locations depicted in accordance with the CI/ASCE Standard 38-02.

Utilities shown on these plans as depicted in the legend have been investigated by TBE Group, Inc in accordance with SUE Industry Standards. All other information shown has been provided to TBE Group, Inc by others. Changes to utilities after dates shown may have been made and therefore may result in variances from this plan. Consideration should be given to updating this plan if deemed advisable prior to final design and construction.



TBE GROUP, INC.
 CIVIL ENGINEERING * TRANSPORTATION * ENVIRONMENTAL
 * PLANNING * UTILITY ENGINEERING/LOCATING

IL09500132, 142, 158, 229, 245
 TBE SUE PAGE NO: 25 of 29
 Checked by: *Sandra Davis*
 Utility Quality Level "A" : Test Holes
 Utility Quality Level "B" : Designating

—T—T—	FORCE MAIN
—T—T—	TELEPHONE
—W—W—	WATER
—G—G—	GAS
—CTV—CTV—	CABLE TELEVISION
—FO—FO—	FIBER OPTIC
—E—E—	ELECTRIC
⊙	TEST HOLE

205 W. WACKER DRIVE
 SUITE 1020
 CHICAGO, IL 60606
 (312) 704-1970

REVISIONS	
NAME	DATE

ILLINOIS DEPARTMENT OF TRANSPORTATION
 SUE Investigation of Underground Utilities
 I-55/I-80 from US RT. 30 to Weber Road
 Section No. 99 (1&2) WRS-1
 Contract No. 62895 and 62896
 Will County
 DRAWN BY : KLC
 SCALE : 1" = 50'
 SQL "B" DATE : 1/17/06

F.A.I. RTE.	SECTION	COUNTY	TOTAL SHEETS	SHEET NO.
55	99 (I&2) WRS-1	Will	227	106
STA.		TO STA.		
FED. ROAD DIST. NO.		ILLINOIS FED. AID PROJECT		

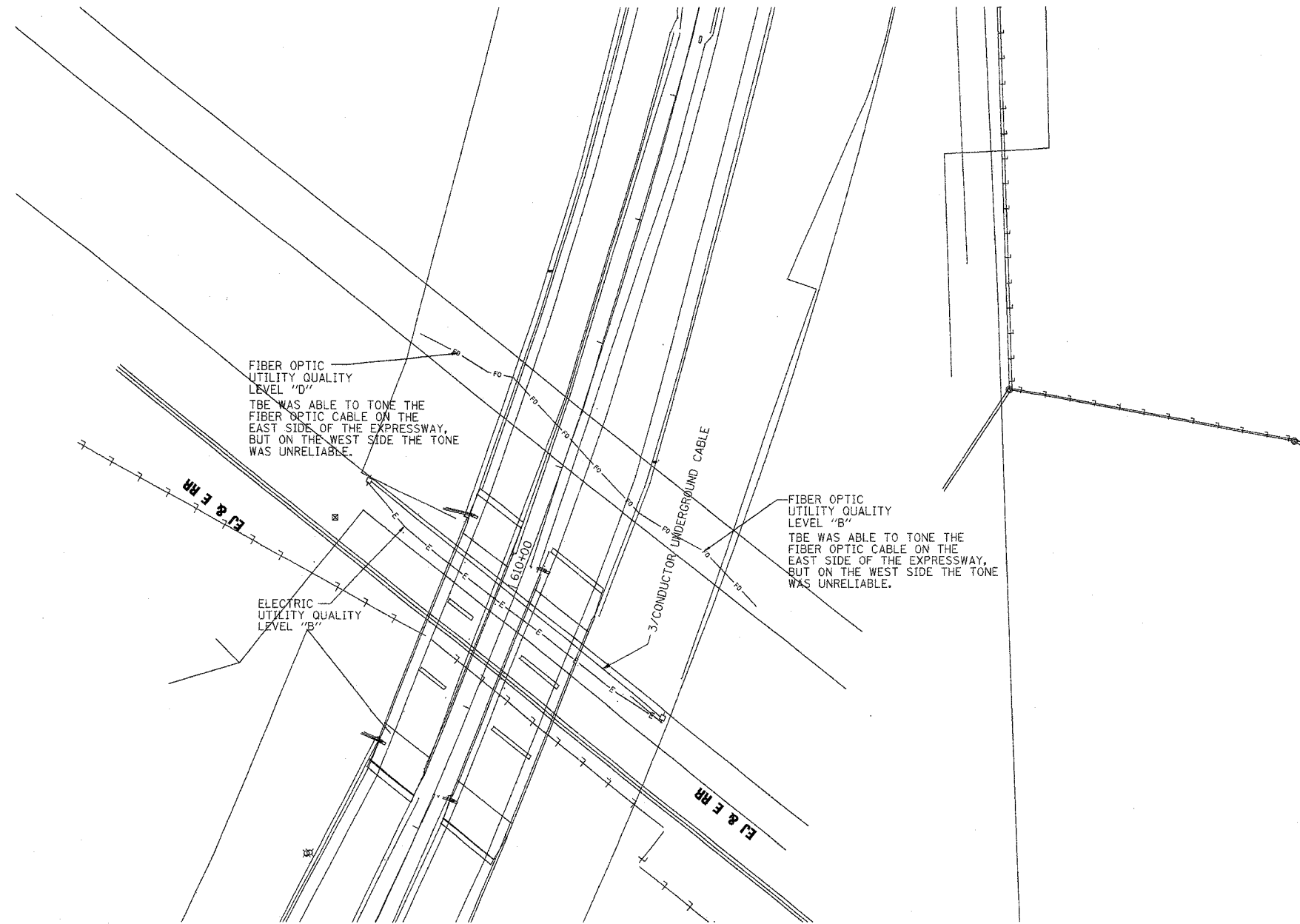

The SBC locations depicted have been obtained through the application of geophysical methods to determine the existence and approximate horizontal position of these facilities. However, SBC will not provide TBE Group, Inc. with utility records nor allow access to their field closures (pedestals/manholes etc.), to help verify the locations of their existing underground facilities. Therefore, TBE is unable to verify the completeness of the SBC locations depicted in accordance with the CI/ASCE Standard 38-02.

Utilities shown on these plans as depicted in the legend have been investigated by TBE Group, Inc in accordance with SUE Industry Standards. All other information shown has been provided to TBE Group, Inc by others. Changes to utilities after dates shown may have been made and therefore may result in variances from this plan. Consideration should be given to updating this plan if deemed advisable prior to final design and construction.



TBE GROUP, INC.
 CIVIL ENGINEERING * TRANSPORTATION * ENVIRONMENTAL
 * PLANNING * UTILITY ENGINEERING/LOCATING

IL09500132, 142, 158, 229, 245

TBE SUE PAGE NO: 26 of 29

Checked by: *Sasha Akers*

Utility Quality Level "A" : Test Holes
 Utility Quality Level "B" : Designating

—●—●—●—●—●—●—	FORCE MAIN
—T—T—T—T—T—T—	TELEPHONE
—W—W—W—W—W—W—	WATER
—G—G—G—G—G—G—	GAS
—CTV—CTV—CTV—CTV—CTV—CTV—	CABLE TELEVISION
—FO—FO—FO—FO—FO—FO—	FIBER OPTIC
—E—E—E—E—E—E—	ELECTRIC
●	TEST HOLE



 205 W. WACKER DRIVE
 SUITE 1020
 CHICAGO, IL 60606
 (312) 704-1970

REVISIONS	
NAME	DATE

ILLINOIS DEPARTMENT OF TRANSPORTATION
 SUE Investigation of Underground Utilities
 I-55/I-80 from US RT. 30 to Weber Road
 Section No. 99 (I&2) WRS-1
 Contract No. 62895 and 62896
 Will County
 DRAWN BY : KLC
 SCALE : 1" = 50'
 SQL "B" DATE : 1/17/06

IL09500245 SHEET 27 of 29 01/20/2006 01:34:02 PM

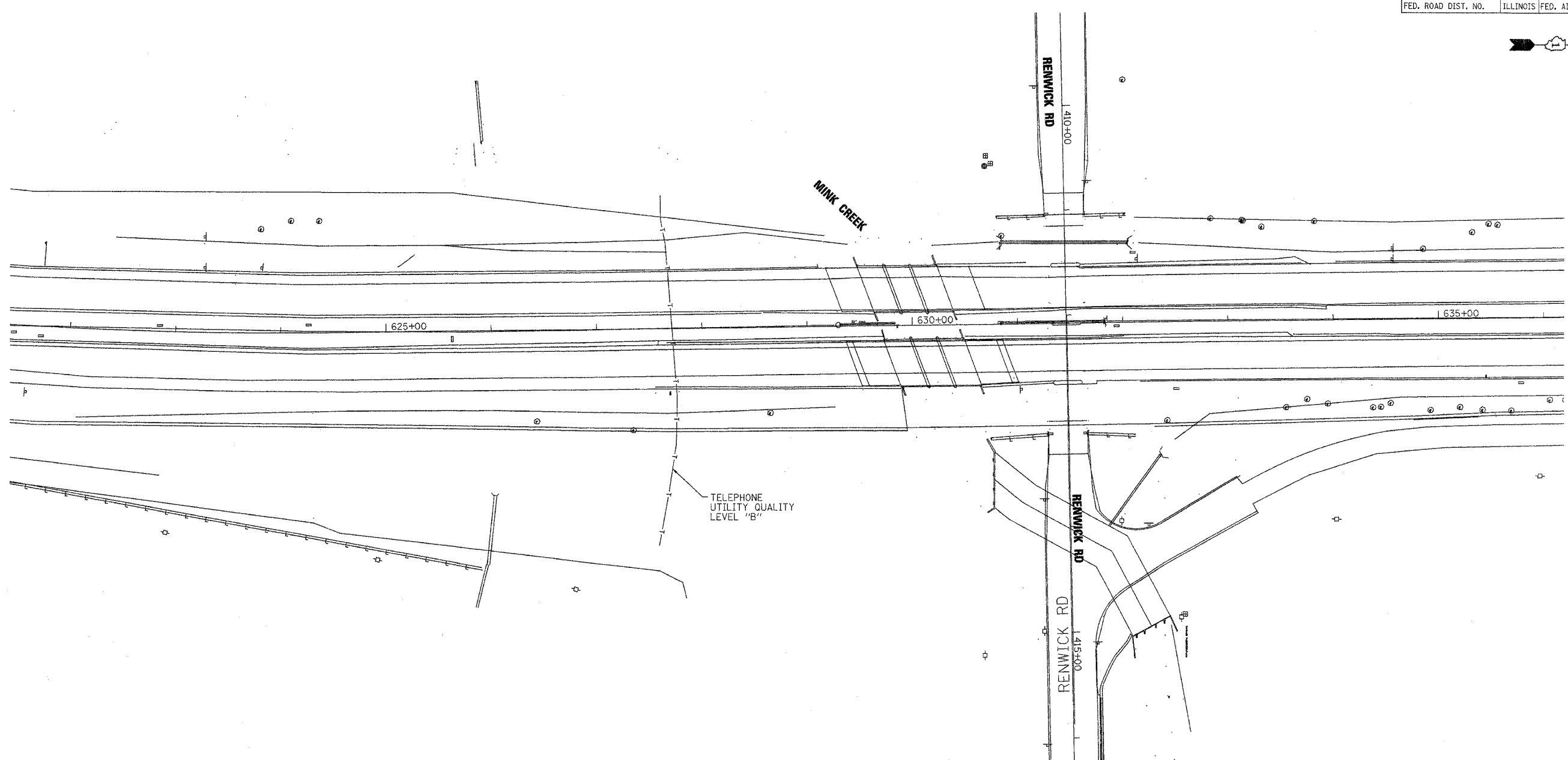
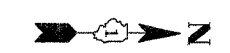
F.A.I. RTE.	SECTION	COUNTY	TOTAL SHEETS	SHEET NO.
55	99 (I&2) WRS-1	WILL	227	107
STA.	TO STA.			
FED. ROAD DIST. NO.	ILLINOIS FED. AID PROJECT			



The SBC locations depicted have been obtained through the application of geophysical methods to determine the existence and approximate horizontal position of these facilities. However, SBC will not provide TBE Group, Inc. with utility records nor allow access to their field closures (pedestals/manholes etc.), to help verify the locations of their existing underground facilities. Therefore, TBE is unable to verify the completeness of the SBC locations depicted in accordance with the CI/ASCE Standard 38-02.

Utilities shown on these plans as depicted in the legend have been investigated by TBE Group, Inc in accordance with SUE Industry Standards. All other information shown has been provided to TBE Group, Inc by others. Changes to utilities after dates shown may have been made and therefore may result in variances from this plan. Consideration should be given to updating this plan if deemed advisable prior to final design and construction.



TBE GROUP, INC.
 CIVIL ENGINEERING * TRANSPORTATION * ENVIRONMENTAL
 * PLANNING * UTILITY ENGINEERING/LOCATING

IL09500132, 142, 158, 229, 245
 TBE SUE PAGE NO: 27 of 29
 Checked by: *Sandra A. Pl...*
 Utility Quality Level "A" : Test Holes
 Utility Quality Level "B" : Designating

	FORCE MAIN
	TELEPHONE
	WATER
	GAS
	CABLE TELEVISION
	FIBER OPTIC
	ELECTRIC
	TEST HOLE

205 W. WACKER DRIVE
 SUITE 1020
 CHICAGO, IL 60606
 (312) 704-1970

REVISIONS	
NAME	DATE

ILLINOIS DEPARTMENT OF TRANSPORTATION
 SUE Investigation of Underground Utilities
 I-55/I-80 from US RT. 30 to Weber Road
 Section No. 99 (I&2) WRS-1
 Contract No. 62895 and 62896
 Will County
 SOL "B" DATE : 1/17/06
 DRAWN BY : KLC
 SCALE : 1" = 50'

IL09500132.dgn 01/20/2006 01:34:38 PM

F.A.I. RTE.	SECTION	COUNTY	TOTAL SHEETS	SHEET NO.
55	99 (1&2) WRS-1	Will	227	108
STA.		TO STA.		
FED. ROAD DIST. NO.		ILLINOIS FED. AID PROJECT		

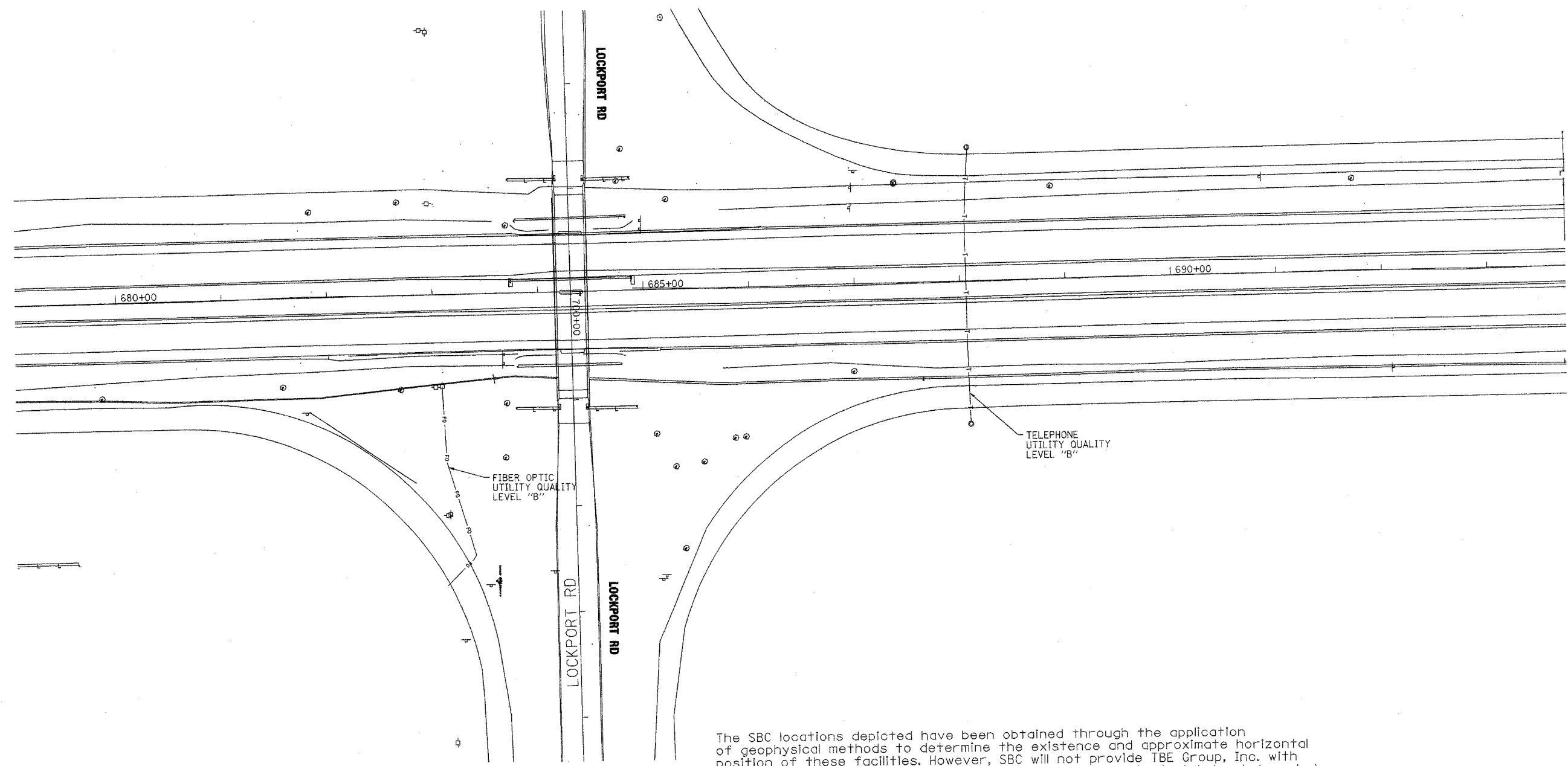

The SBC locations depicted have been obtained through the application of geophysical methods to determine the existence and approximate horizontal position of these facilities. However, SBC will not provide TBE Group, Inc. with utility records nor allow access to their field closures (pedestals/manholes etc.), to help verify the locations of their existing underground facilities. Therefore, TBE is unable to verify the completeness of the SBC locations depicted in accordance with the CI/ASCE Standard 38-02.

Utilities shown on these plans as depicted in the legend have been investigated by TBE Group, Inc in accordance with SUE Industry Standards. All other information shown has been provided to TBE Group, Inc by others. Changes to utilities after dates shown may have been made and therefore may result in variances from this plan. Consideration should be given to updating this plan if deemed advisable prior to final design and construction.



TBE GROUP, INC.
 CIVIL ENGINEERING * TRANSPORTATION * ENVIRONMENTAL
 * PLANNING * UTILITY ENGINEERING/LOCATING

IL09500132, 142, 158, 229, 245
 TBE SUE PAGE NO: 28 of 29
 Checked by: *Sada Lopez*
 Utility Quality Level "A" : Test Holes
 Utility Quality Level "B" : Designating

—●—●—●—●—●—●—	FORCE MAIN
—T—T—T—T—T—T—	TELEPHONE
—W—W—W—W—W—W—	WATER
—G—G—G—G—G—G—	GAS
—CTV—CTV—CTV—CTV—CTV—CTV—	CABLE TELEVISION
—FO—FO—FO—FO—FO—FO—	FIBER OPTIC
—E—E—E—E—E—E—	ELECTRIC
—●—	TEST HOLE

205 W. WACKER DRIVE
 SUITE 1020
 CHICAGO, IL 60606
 (312) 704-1970

REVISIONS	
NAME	DATE

ILLINOIS DEPARTMENT OF TRANSPORTATION
 SUE Investigation of Underground Utilities
 I-55/I-80 from US RT. 30 to Weber Road
 Section No. 99 (1&2) WRS-1
 Contract No. 62895 and 62896
 Will County
 DRAWN BY : KLC
 SCALE : 1" = 50'
 SQL "B" DATE : 1/17/06

F.A.P. DIST.	SECTION	COUNTY	TOTAL SHEETS	SHEET NO.
55	100 (1&2) I-9	WILL	227	109
STA. 594+66.34		TO STA. 607+00		
FED. ROAD DIST. NO.		ILLINOIS FED. AID PROJECT		
PVMRK-1 OF 27				

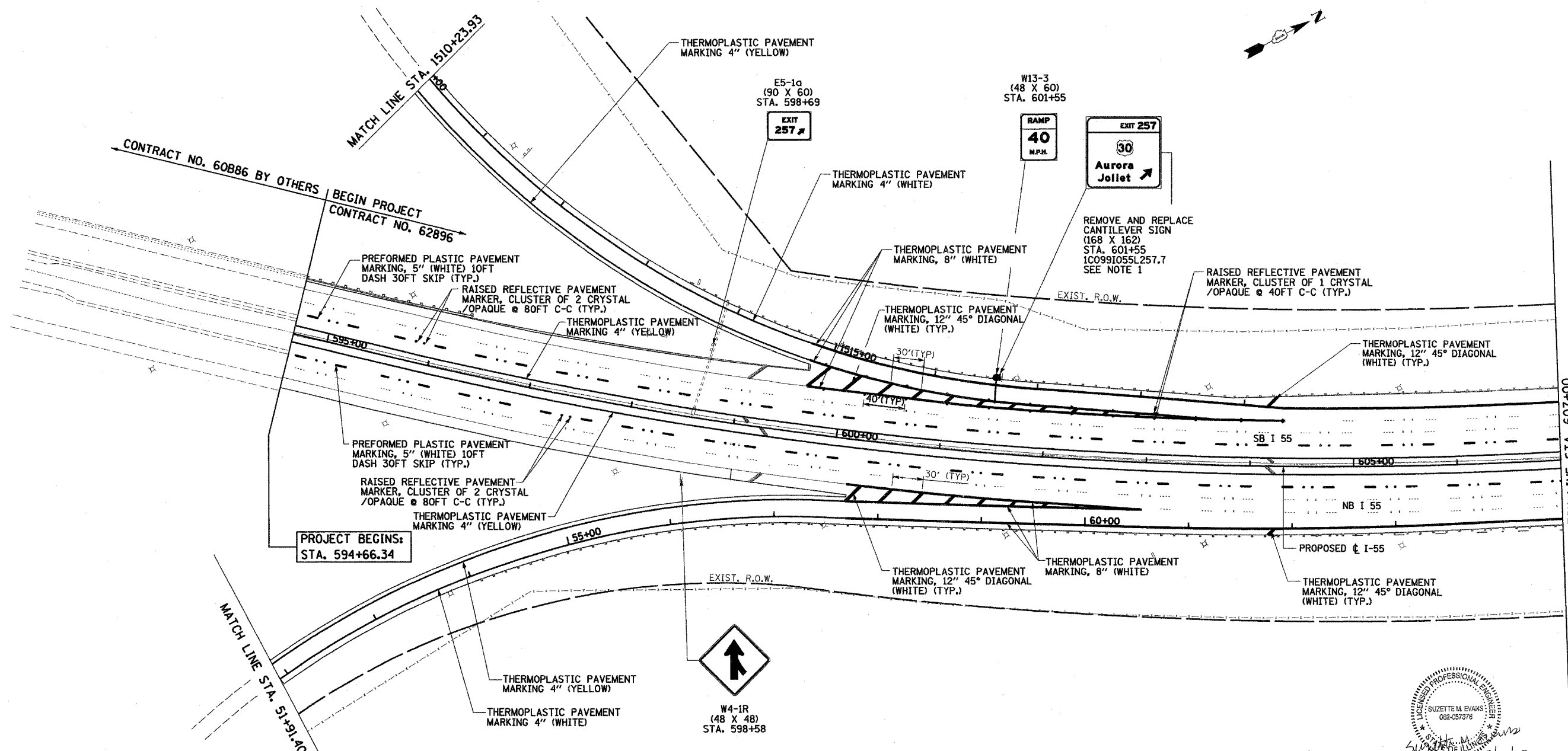

PROJECT BEGINS:
STA. 594+66.34

NOTE:

- CONTRACTOR TO INSTALL A 3 1/2" PVC CONDUIT LARGE RADIUS ELBOW IN THE BASE OF CANTILEVER SIGN FOUNDATION. TOP OF CONDUIT ENTRY INTO FOUNDATION SHALL BE A MINIMUM OF 30" BELOW GRADE. STUB AND CAP FOR FUTURE USE. COST IS INCIDENTAL TO "DRILLED SHAFT CONCRETE FOUNDATIONS."
- THE CONTRACTOR SHALL TRANSPORT AND DROP OFF ALL SALVAGEABLE SIGNS AT THE IDOT NEW LENOX SIGN SHOP LOCATED AT THE SE FRONTAGE ROAD NEAR THE US ROUTE 30 & INTERSTATE 80 INTERCHANGE IN NEW LENOX, ILLINOIS. THE CONTACT PERSON IS CONNIE SHANAHAN (847-705-4501). THIS WORK SHALL MEET WITH THE APPROVAL OF THE ENGINEER AND THE COST SHALL BE INCLUDED IN THE CONTRACT UNIT PRICE FOR "REMOVE SIGN PANEL ASSEMBLY" OF THE TYPE SPECIFIED OR "REMOVE SIGN PANEL - TYPE 3."

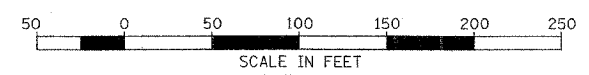

Exp. 11/30/07

Civil Engineering
 Structural Engineering
 Surveying
 445 S. Illinois, Suite 610
 Chicago, IL 60611
 (312) 942-9800

PARSONS BRINCKERHOFF

REVISIONS	
NAME	DATE

ILLINOIS DEPARTMENT OF TRANSPORTATION
 F.A.I. I-55
 US RTE. 30 TO 143rd STREET
 PAVEMENT MARKING
 AND SIGNING PLANS
 SCALE: 1" = 50'
 DATE: FEBRUARY 23, 2007
 DRAWN BY: JS, LC
 CHECKED BY: SE

F.A.P. RTE.	SECTION	COUNTY	TOTAL SHEETS	SHEET NO.
55	100 (I&2) I-9	WILL	227	110
STA. 607+00	TO STA. 608+26.93			
FED. ROAD DIST. NO.	ILLINOIS	FED. AID PROJECT		
PVMRK - 2 OF 27				



END PROPOSED PAVEMENT MARKING AND SIGNING

MATCH EXISTING PAVEMENT MARKINGS

STA. 608+26.93

MATCH LINE STA. 607+00

EJ & E RAILROAD

- RAISED REFLECTIVE PAVEMENT MARKER, CLUSTER OF 2 CRYSTAL / OPAQUE @ 80FT C-C (TYP.)
- PREFORMED PLASTIC PAVEMENT MARKING, 5" (WHITE) 10FT DASH 30FT SKIP (TYP.)
- THERMOPLASTIC PAVEMENT MARKING 4" (YELLOW)
- THERMOPLASTIC PAVEMENT MARKING 8" (WHITE)

- THERMOPLASTIC PAVEMENT MARKING 4" (YELLOW)
- RAISED REFLECTIVE PAVEMENT MARKER, CLUSTER OF 2 CRYSTAL / OPAQUE @ 80FT C-C (TYP.)
- PREFORMED PLASTIC PAVEMENT MARKING, 5" (WHITE) 10FT DASH 30FT SKIP (TYP.)
- THERMOPLASTIC PAVEMENT MARKING 8" (WHITE)

EXIST. R.O.W.

PROPOSED ϕ I-55

SB I-55

I-615+00

NB I-55

I-620+00

EXIST. R.O.W.

EXIST. R.O.W.

CONSTRUCTION RESUMES AT STA. 641+00
SEE PVMRK - 3

EXIST

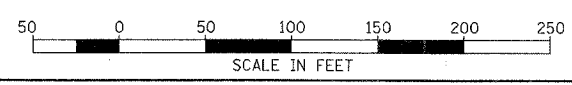

DAVID MASON & ASSOCIATES
Civil Engineering
Structural Engineering
Surveying
448 E. Illinois, Suite 640
Chicago, IL 60611
(312) 942-9600

PARSONS BRINCKERHOFF

REVISIONS	
NAME	DATE

ILLINOIS DEPARTMENT OF TRANSPORTATION
F.A.I. I-55
US RTE. 30 TO 143rd STREET

PAVEMENT MARKING AND SIGNING PLANS

SCALE: 1" = 50'
DATE: FEBRUARY 23, 2007

DRAWN BY: JS, LC
CHECKED BY: SE

F.A.P. RTE.	SECTION	COUNTY	TOTAL SHEETS	SHEET NO.
55	100 (1&2) I-9	WILL.	227	111
STA.	641+00	TO STA.	652+00	
FED. ROAD DIST. NO.	ILLINOIS FED. AID PROJECT			
PVMRK-3 OF 27				

CONSTRUCTION RESUMES AT STA. 608+26.93
SEE PVMRK-2

MATCH EXISTING PAVEMENT MARKINGS
 STA. 641+00.00
 BEGIN PROPOSED PAVEMENT MARKING AND SIGNING

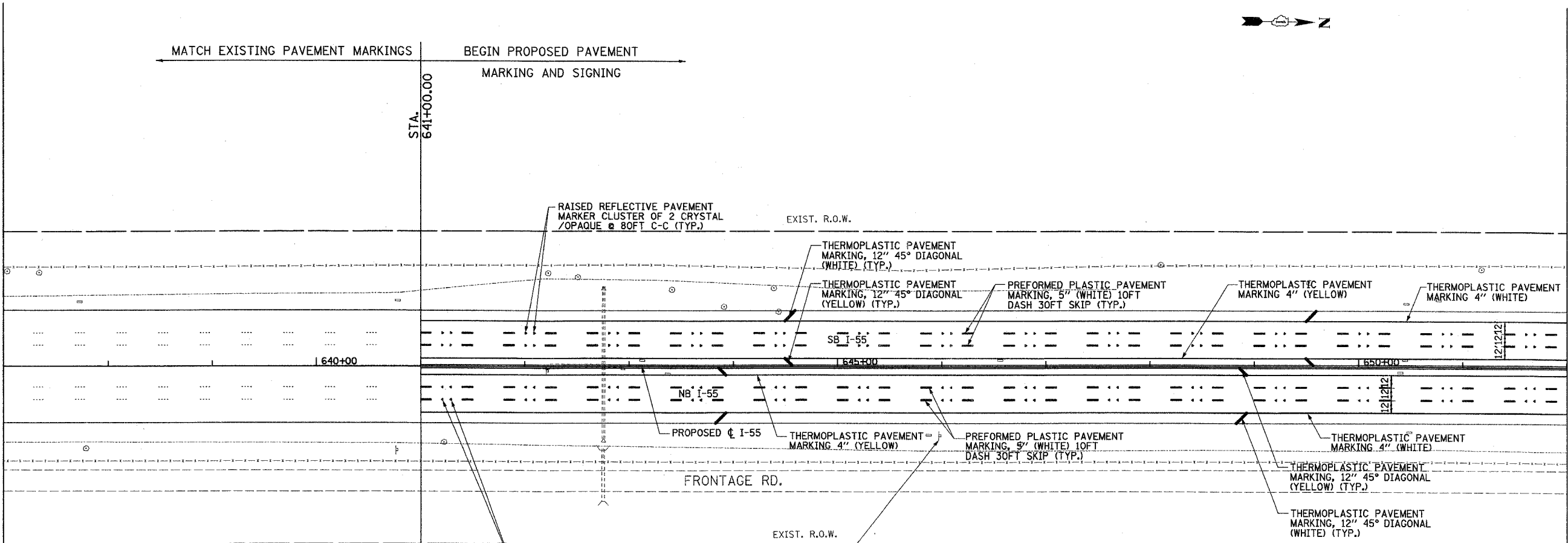
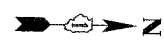

MATCH LINE STA. 652+00

RAISED REFLECTIVE PAVEMENT MARKER CLUSTER OF 2 CRYSTAL / OPAQUE @ 80FT C-C (TYP.)

SPEED LIMIT
 OVER 4 TONS
 MOTOR HOMES
 CAMPERS
 TRAILERS
55

(48 X 96)
 STA. 645+97

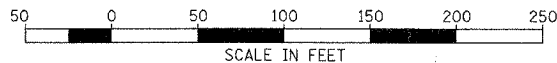

DAVID MASON & ASSOCIATES
 Civil Engineering
 Structural Engineering
 Surveying
 645 E. Illinois, Suite 649
 Chicago, IL 60611
 (312) 942-9800

PARSONS BRINCKERHOFF

REVISIONS	
NAME	DATE

ILLINOIS DEPARTMENT OF TRANSPORTATION
 F.A.I. I-55
 US RTE. 30 TO 143rd STREET

PAVEMENT MARKING AND SIGNING PLANS

SCALE: 1" = 50'
 DATE: FEBRUARY 23, 2007

DRAWN BY: JS, LC
 CHECKED BY: SE

CONTRACT NO. 62896				
F.A.P. RTE.	SECTION	COUNTY	TOTAL SHEETS	SHEET NO.
55	100 (I&2) I-9	WILL	227	112
STA. 652+00	TO STA. 667+00			
FED. ROAD DIST. NO.	ILLINOIS FED. AID PROJECT			
	PVMRK-4 OF 27			

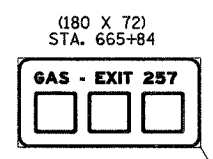
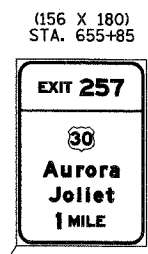
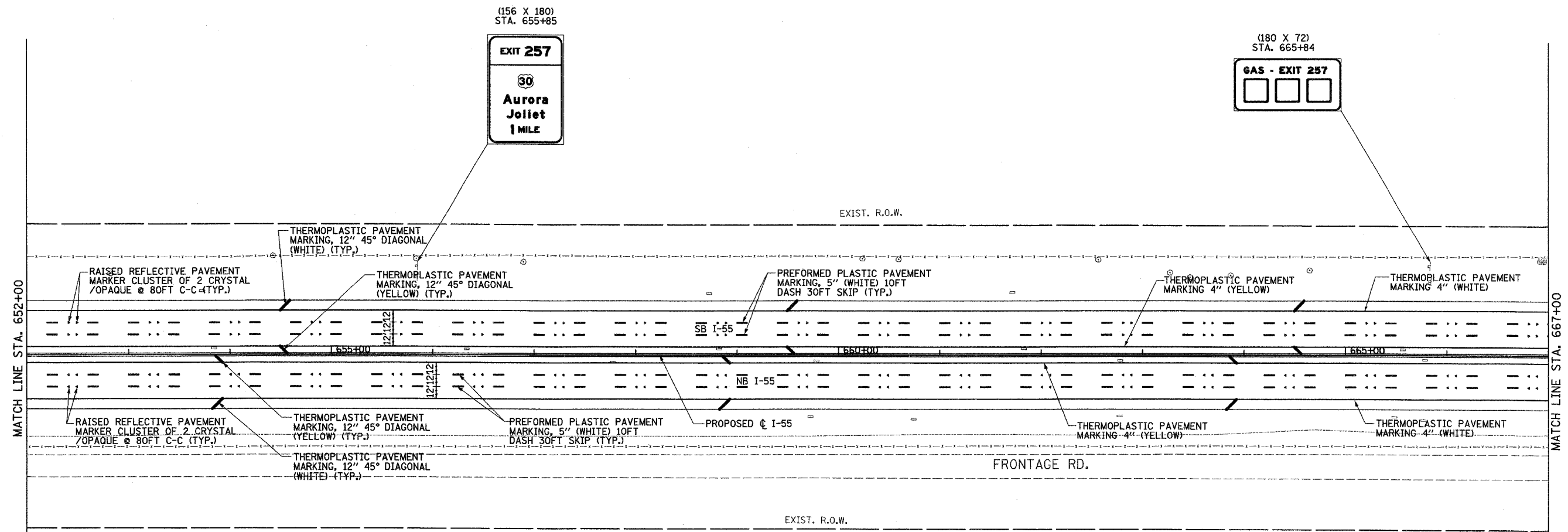
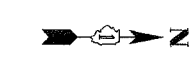

MATCH LINE STA. 652+00

MATCH LINE STA. 667+00

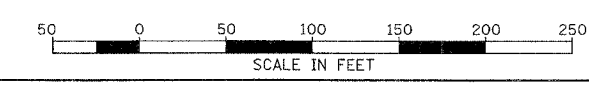

DAVID MASON & ASSOCIATES
Civil Engineering
Structural Engineering
Surveying
445 E. Illinois, Suite 640
Chicago, IL 60611
(312) 942-8600

PB PARSONS BRINCKERHOFF

REVISIONS	
NAME	DATE

ILLINOIS DEPARTMENT OF TRANSPORTATION
F.A.I. I-55
US RTE. 30 TO 143rd STREET

PAVEMENT MARKING
AND SIGNING PLANS

SCALE: 1" = 50'
DATE: FEBRUARY 23, 2007

DRAWN BY: JS, LC
CHECKED BY: SE

F.A.P. RTE.	SECTION	COUNTY	TOTAL SHEETS	SHEET NO.
55	100 (I&2) I-9	WILL	227	113
STA. 667+00		TO STA. 682+00		
FED. ROAD DIST. NO.		ILLINOIS	FED. AID PROJECT	
PVMRK- 5 OF 27				

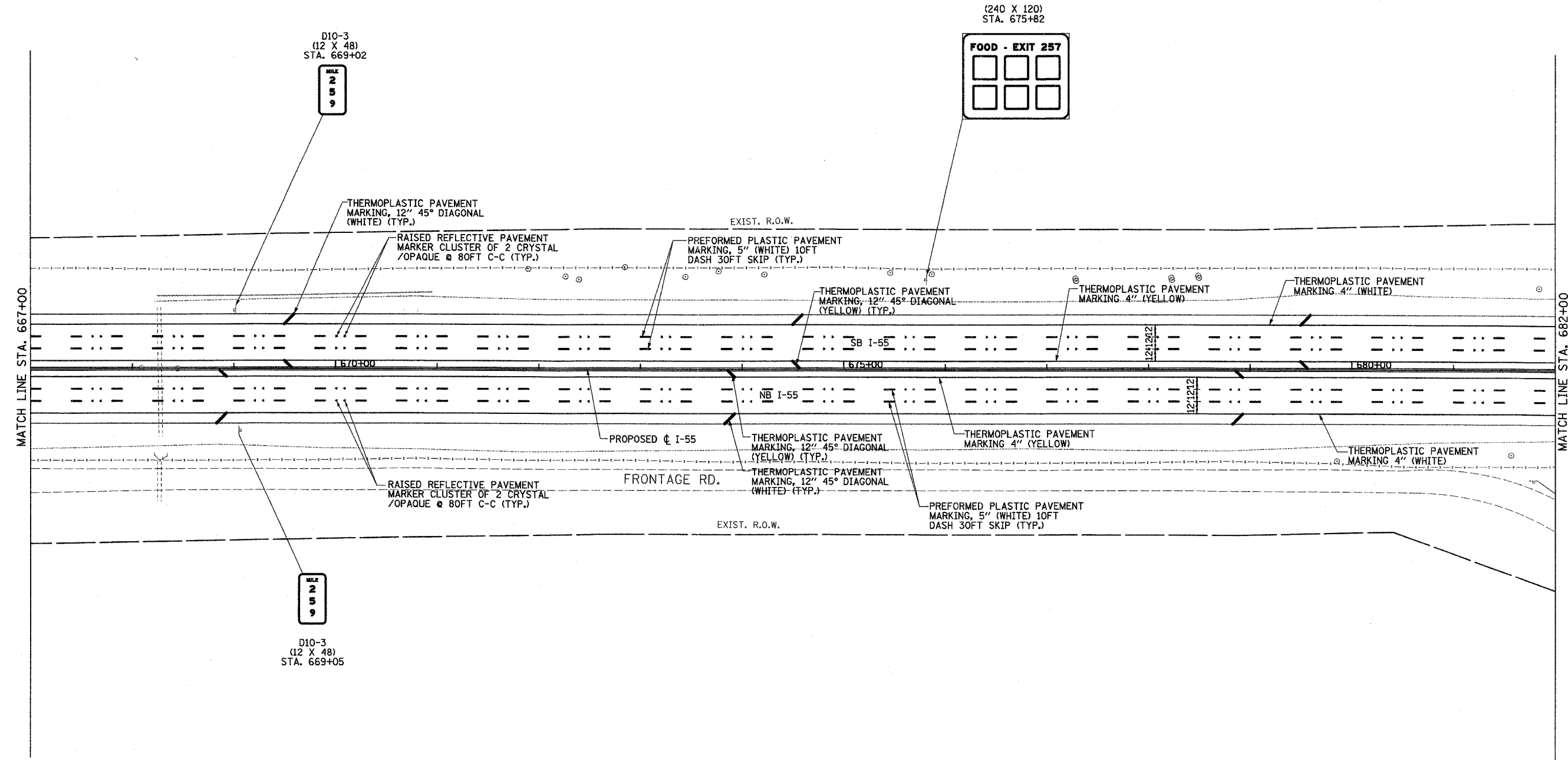

MATCH LINE STA. 667+00

MATCH LINE STA. 682+00

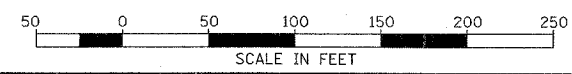

DAVID MASON & ASSOCIATES
Civil Engineering
Structural Engineering
Surveying
440 E. Illinois, Suite 640
Chicago, IL 60611
(312) 942-9600

PARSONS BRINCKERHOFF

REVISIONS	
NAME	DATE

ILLINOIS DEPARTMENT OF TRANSPORTATION
F.A.I. I-55
US RTE. 30 TO 143rd STREET

PAVEMENT MARKING
AND SIGNING PLANS

SCALE: 1" = 50'
DATE: FEBRUARY 23, 2007

DRAWN BY: JS, LC
CHECKED BY: SE

CONTRACT NO. 62896				
F.A.P. RTE.	SECTION	COUNTY	TOTAL SHEETS	SHEET NO.
55	100 (I&2) I-9	WILL	227	114
STA. 682+00	TO STA. 697+00			
FED. ROAD DIST. NO.	ILLINOIS	FED. AID PROJECT		
PVMRK-6 OF 27				

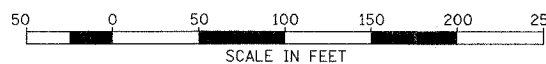
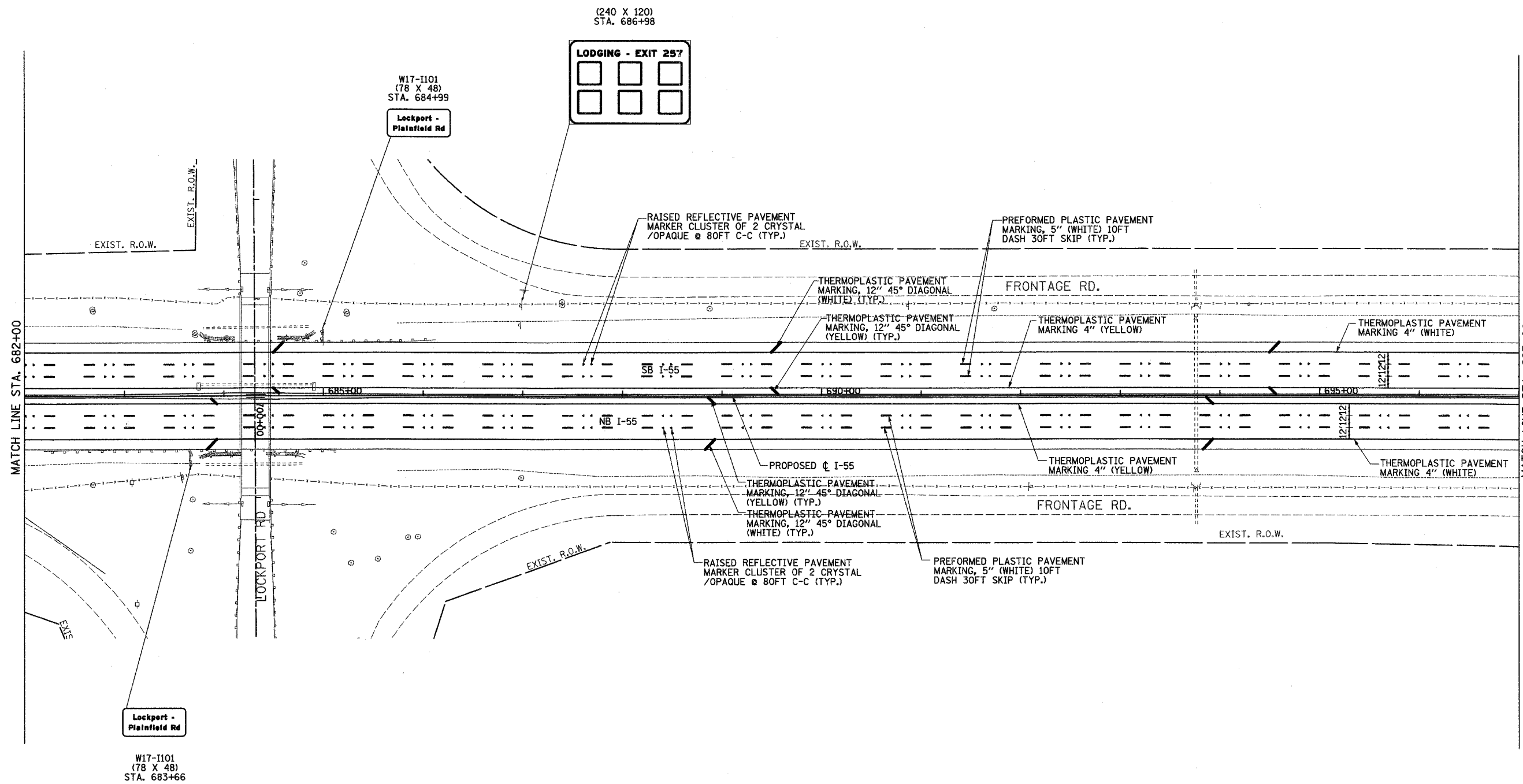

DAVID MASON & ASSOCIATES
Civil Engineering
Structural Engineering
Surveying
445 E. Illinois, Suite 640
Chicago, IL 60611
(312) 942-9890

PB PARSONS BRINCKERHOFF

REVISIONS	
NAME	DATE

ILLINOIS DEPARTMENT OF TRANSPORTATION
F.A.I. I-55
US RTE. 30 TO 143rd STREET

PAVEMENT MARKING
AND SIGNING PLANS

SCALE: 1" = 50'
DATE: FEBRUARY 23, 2007

DRAWN BY: JS, LC
CHECKED BY: SE

F.A.P. SECTION	COUNTY	TOTAL SHEETS	SHEET NO.
5S 100 (1&2) I-9	WILL	227	115
STA. 697+00 TO STA. 700+00			
FED. ROAD DIST. NO. ILLINOIS		FED. AID PROJECT	
PVMRK- 7 OF 27			

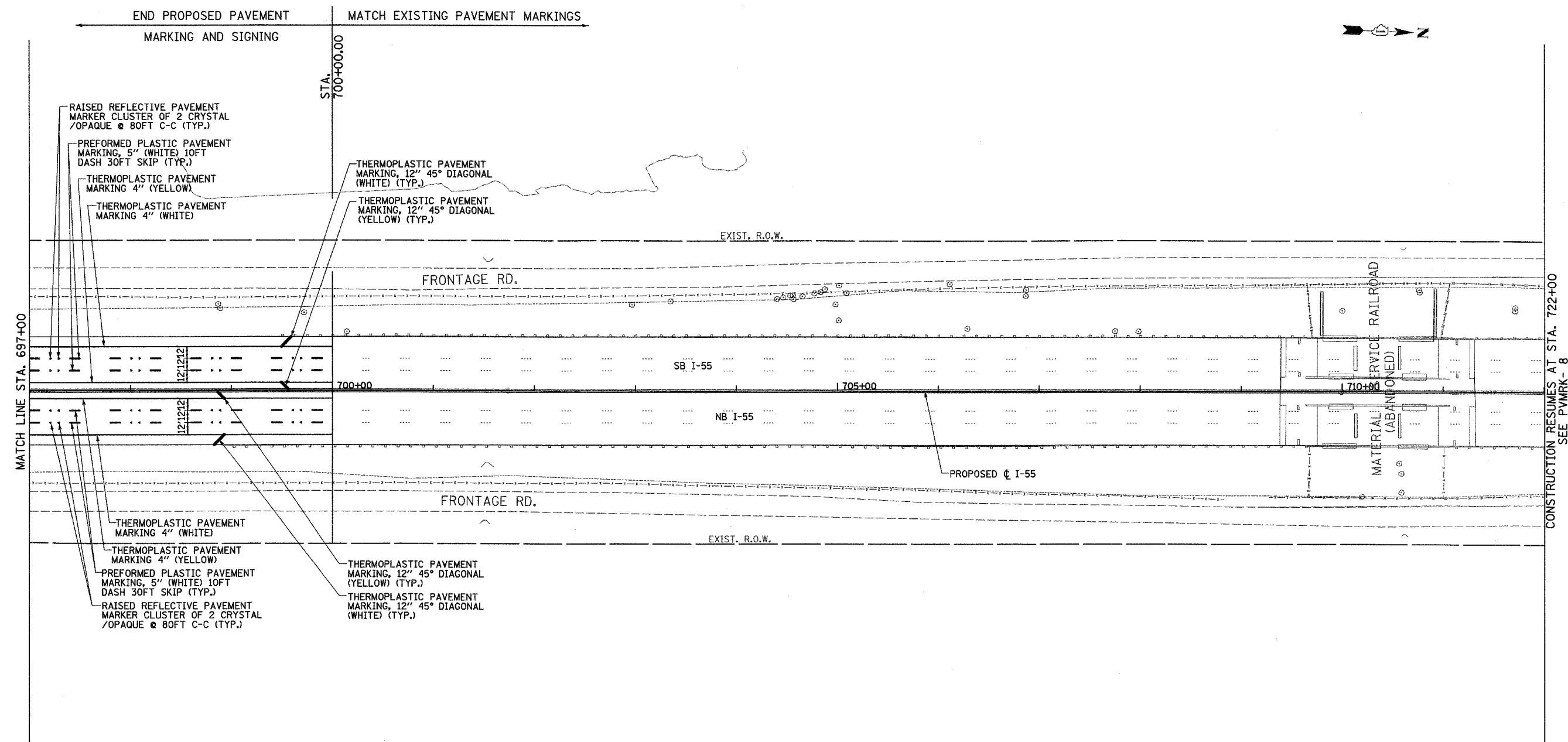

MATCH LINE STA. 697+00

STA. 700+00.00

CONSTRUCTION RESUMES AT STA. 722+00
SEE PVMRK- 8

- RAISED REFLECTIVE PAVEMENT MARKER CLUSTER OF 2 CRYSTAL / OPAQUE @ 80FT C-C (TYP.)
- PREFORMED PLASTIC PAVEMENT MARKING, 5" (WHITE) 10FT DASH 30FT SKIP (TYP.)
- THERMOPLASTIC PAVEMENT MARKING 4" (YELLOW)
- THERMOPLASTIC PAVEMENT MARKING 4" (WHITE)

- THERMOPLASTIC PAVEMENT MARKING, 12" 45° DIAGONAL (WHITE) (TYP.)
- THERMOPLASTIC PAVEMENT MARKING, 12" 45° DIAGONAL (YELLOW) (TYP.)

- THERMOPLASTIC PAVEMENT MARKING 4" (WHITE)
- THERMOPLASTIC PAVEMENT MARKING 4" (YELLOW)
- PREFORMED PLASTIC PAVEMENT MARKING, 5" (WHITE) 10FT DASH 30FT SKIP (TYP.)
- RAISED REFLECTIVE PAVEMENT MARKER CLUSTER OF 2 CRYSTAL / OPAQUE @ 80FT C-C (TYP.)

- THERMOPLASTIC PAVEMENT MARKING, 12" 45° DIAGONAL (YELLOW) (TYP.)
- THERMOPLASTIC PAVEMENT MARKING, 12" 45° DIAGONAL (WHITE) (TYP.)

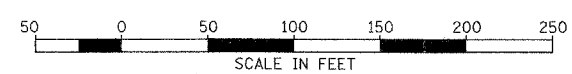

DAVID MASON & ASSOCIATES
Civil Engineering
Structural Engineering
Surveying
445 E. Illinois, Suite 640
Chicago, IL 60611
(312) 942-9800

PB PARSONS BRINCKERHOFF

REVISIONS	
NAME	DATE

ILLINOIS DEPARTMENT OF TRANSPORTATION
F.A.I. I-55
US RTE. 30 TO 143rd STREET

PAVEMENT MARKING
AND SIGNING PLANS

SCALE: 1" = 50'
DATE: FEBRUARY 23, 2007

DRAWN BY: JS, LC
CHECKED BY: SE

F.A.P. RTE.	SECTION	COUNTY	TOTAL SHEETS	SHEET NO.
55	100 (1&2) I-9	WILL	227	116
STA. 722+00		TO STA. 727+00		
FED. ROAD DIST. NO.		ILLINOIS	FED. AID PROJECT	
PVMRK- 8 OF 27				



MATCH EXISTING PAVEMENT MARKINGS
 BEGIN PROPOSED PAVEMENT MARKING AND SIGNING

STA. 722+00.00

CONSTRUCTION RESUMES AT STA. 700+00
 SEE PVMRK- 7

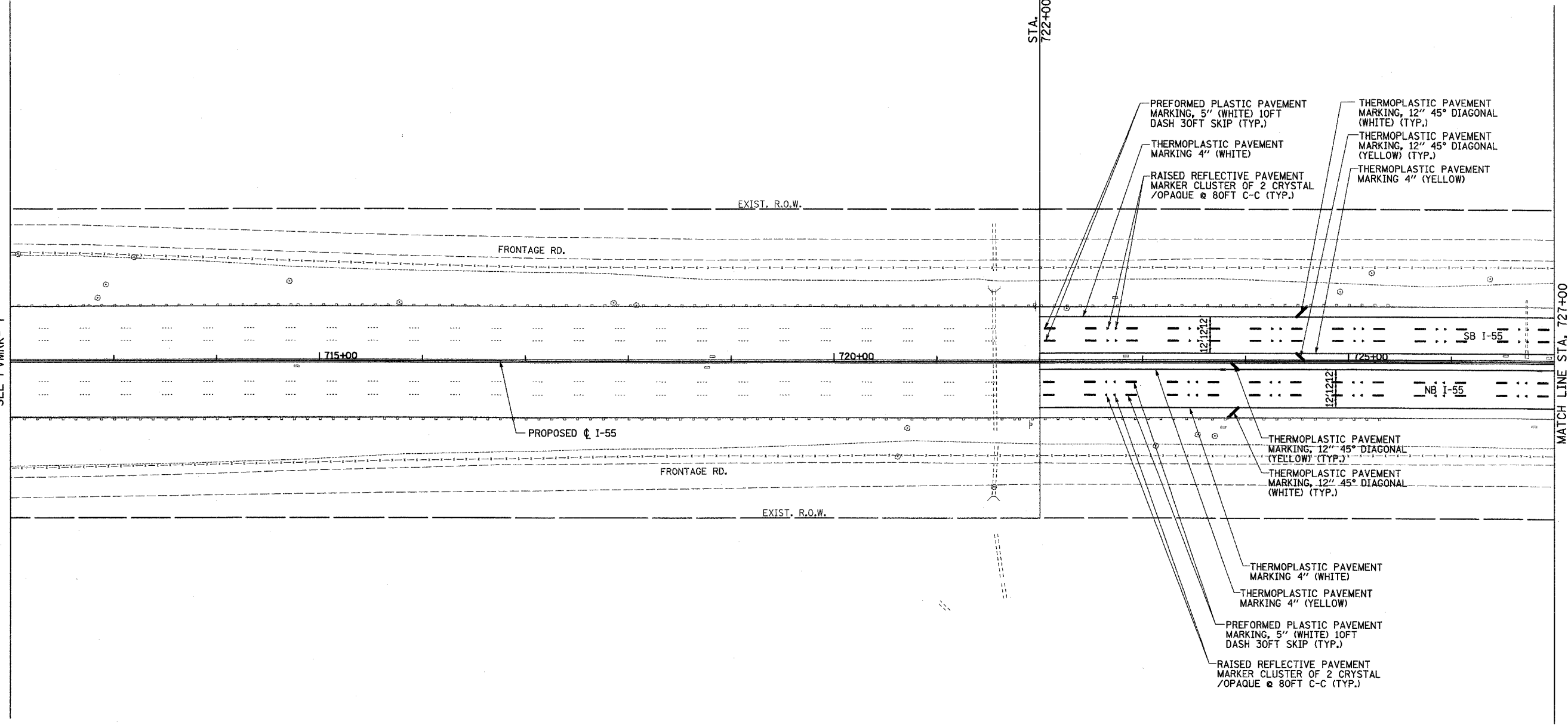

MATCH LINE STA. 727+00

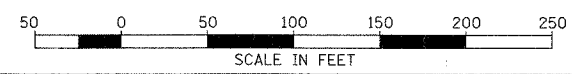

DAVID MASON & ASSOCIATES
 Civil Engineering
 Structural Engineering
 Surveying
 445 E. Illinois, Suite 640
 Chicago, IL 60611
 (312) 942-9600

PARSONS BRINCKERHOFF

REVISIONS	
NAME	DATE

ILLINOIS DEPARTMENT OF TRANSPORTATION
 F.A.I. I-55
 US RTE. 30 TO 143rd STREET

PAVEMENT MARKING AND SIGNING PLANS

SCALE: 1" = 50'
 DATE: FEBRUARY 23, 2007

DRAWN BY: JS, LC
 CHECKED BY: SE

F.A.P. RTE.	SECTION	COUNTY	TOTAL SHEETS	SHEET NO.
55	100 (1&2) I-9	WILL	227	117
STA.	727+00	TO STA.	742+00	
FED. ROAD DIST. NO.	ILLINOIS FED. AID PROJECT		PVMRK-9 OF 27	

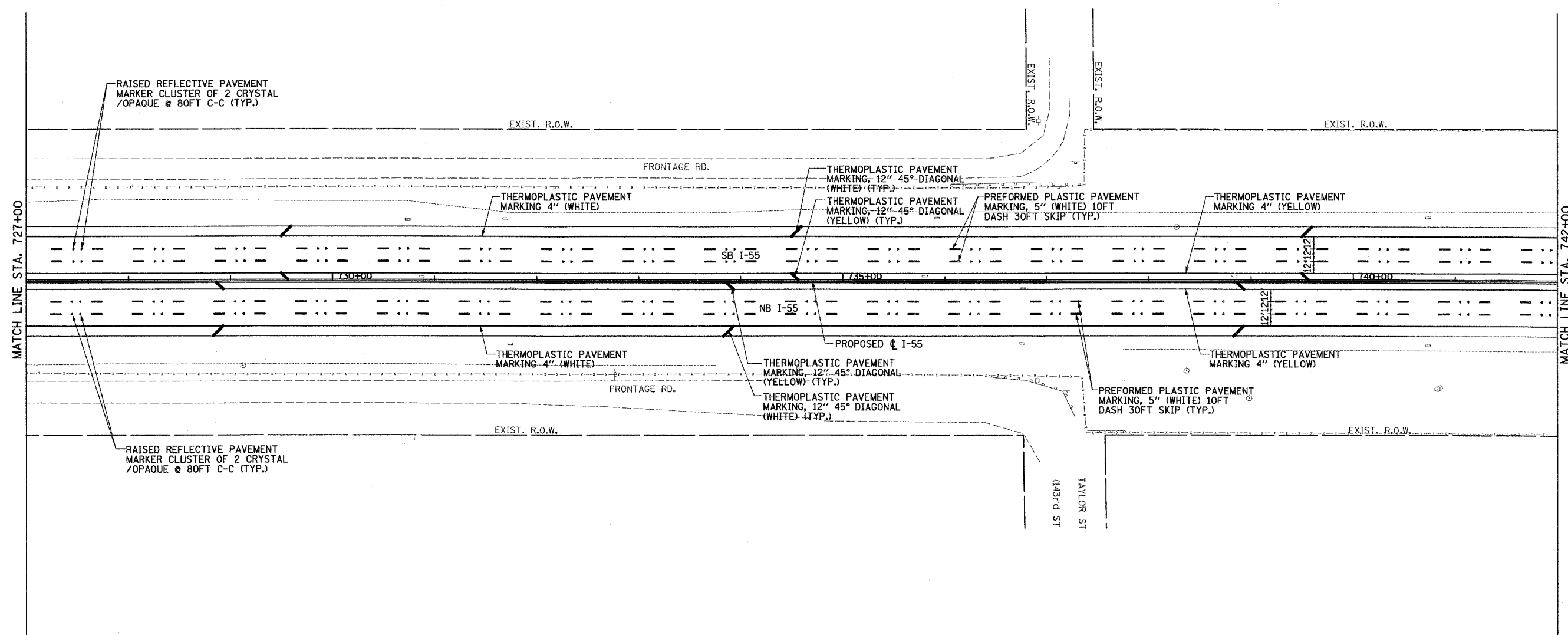

MATCH LINE STA. 727+00

MATCH LINE STA. 742+00

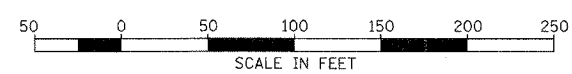

DAVID MASON & ASSOCIATES
Civil Engineering
Structural Engineering
Surveying
445 E. Illinois, Suite 640
Chicago, IL 60611
(312) 842-9600

PARSONS BRINCKERHOFF

REVISIONS	
NAME	DATE

ILLINOIS DEPARTMENT OF TRANSPORTATION
F.A.I. I-55
US RTE. 30 TO 143rd STREET

PAVEMENT MARKING
AND SIGNING PLANS

SCALE: 1" = 50'
DATE: FEBRUARY 23, 2007

DRAWN BY: JS, LC
CHECKED BY: SE

CONTRACT NO. 62896				
F.A.P. RTE.	SECTION	COUNTY	TOTAL SHEETS	SHEET NO.
55	100 (1&2) I-9	WILL.	227	118
STA.	742+00	TO STA.	751+75	
FED. ROAD DIST. NO.	ILLINOIS	FED. AID PROJECT	PVMRK-10 OF 27	

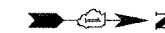

END PROJECT CONTRACT NO. 62896 | BEGIN PROJECT CONTRACT NO. 60B47

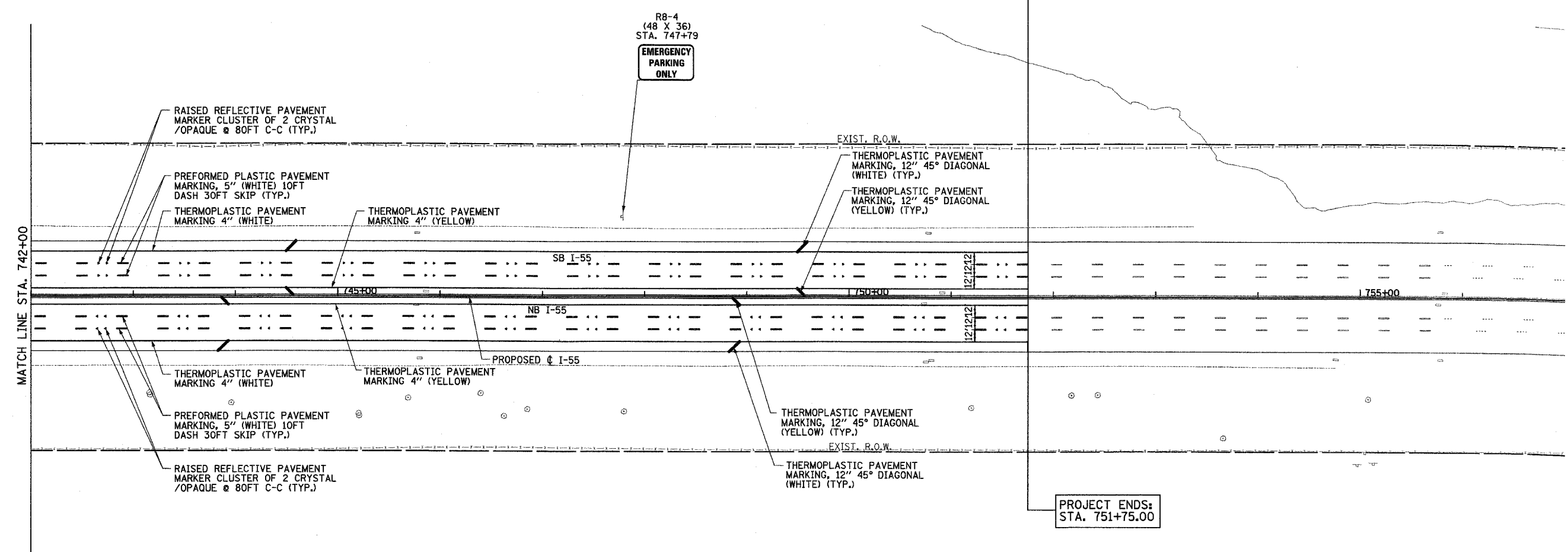

BOTH CONTRACTS WILL BE BUILT SIMULTANEOUSLY -
CONTRACTOR MUST COORDINATE WITH OTHER
CONTRACTOR AT NO ADDITIONAL COST TO THE CONTRACT

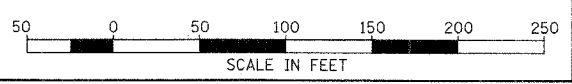

DAVID MASON & ASSOCIATES
Civil Engineering
Structural Engineering
Surveying
443 N. Illinois, Suite 840
Chicago, IL 60611
(312) 942-9808

PB PARSONS BRINCKERHOFF

REVISIONS	
NAME	DATE

ILLINOIS DEPARTMENT OF TRANSPORTATION
F.A.I. I-55
US RTE. 30 TO 143rd STREET

PAVEMENT MARKING
AND SIGNING PLANS

SCALE: 1" = 50'
DATE: FEBRUARY 23, 2007

DRAWN BY: JS, LC
CHECKED BY: SE

CONTRACT NO. 62896			
F.A.P. RTE.	SECTION	COUNTY	TOTAL SHEET NO.
55	100 (1&2) I-9	WILL	227 119
STA.		TO STA.	
FED. ROAD DIST. NO.	ILLINOIS	FED. AID PROJECT	
		DETL5-11 OF 27	

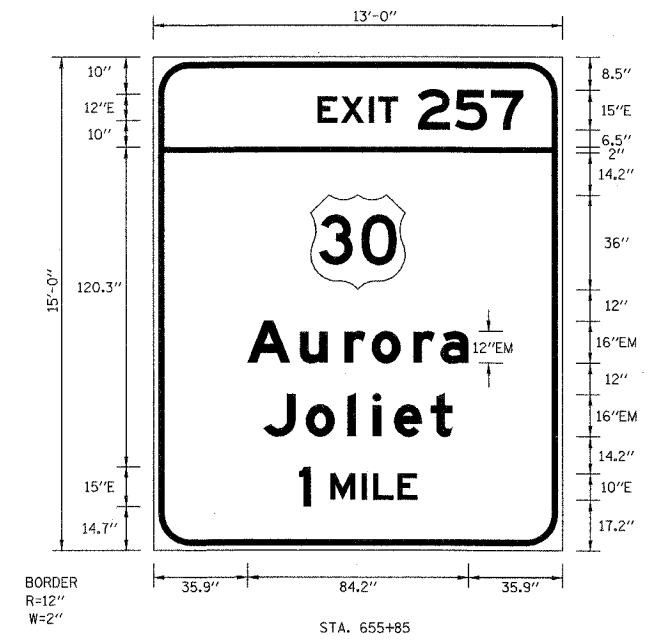
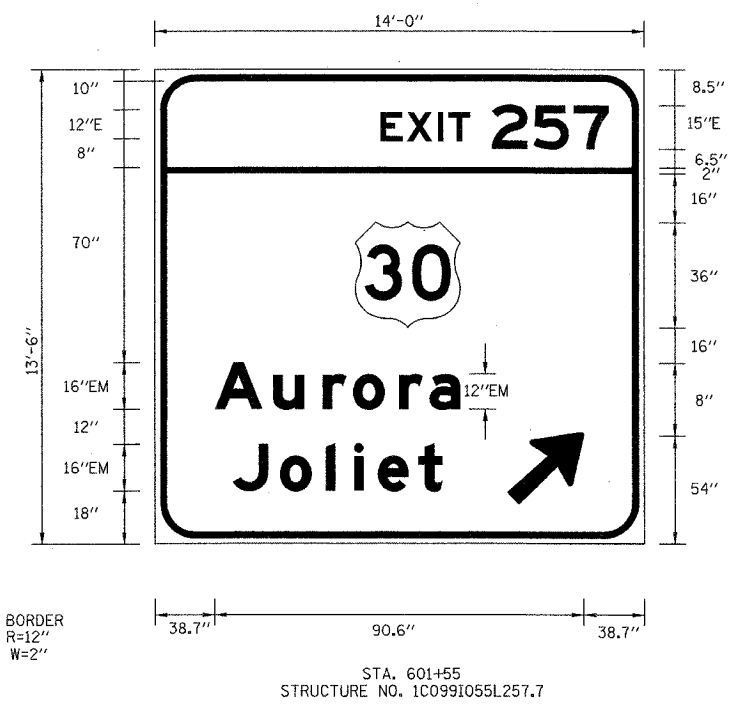

NOTE:
ALL SIGN PANELS SHALL HAVE
WHITE LEGEND, GREEN REFLECTORIZED
BACKGROUND UNLESS NOTED

DAVID MASON & ASSOCIATES
Civil Engineering
Structural Engineering
Surveying
445 E. Illinois, Suite 940
Chicago, IL 60611
(312) 942-9600

PARSONS BRINCKERHOFF

REVISIONS	
NAME	DATE

ILLINOIS DEPARTMENT OF TRANSPORTATION
F.A.I. I-55
US RTE. 30 TO 143rd STREET
SIGN PANEL DETAILS

SCALE:
DATE: FEBRUARY 23, 2007

DRAWN BY: JS, LC
CHECKED BY: SE

F.A.P. RTE.	SECTION	COUNTY	TOTAL SHEETS	SHEET NO.
55	100 (I&2) I-9	WILL	227	120
STA.		TO STA.		
FED. ROAD DIST. NO.	ILLINOIS	FED. AID PROJECT		
DETL-12 OF 27				

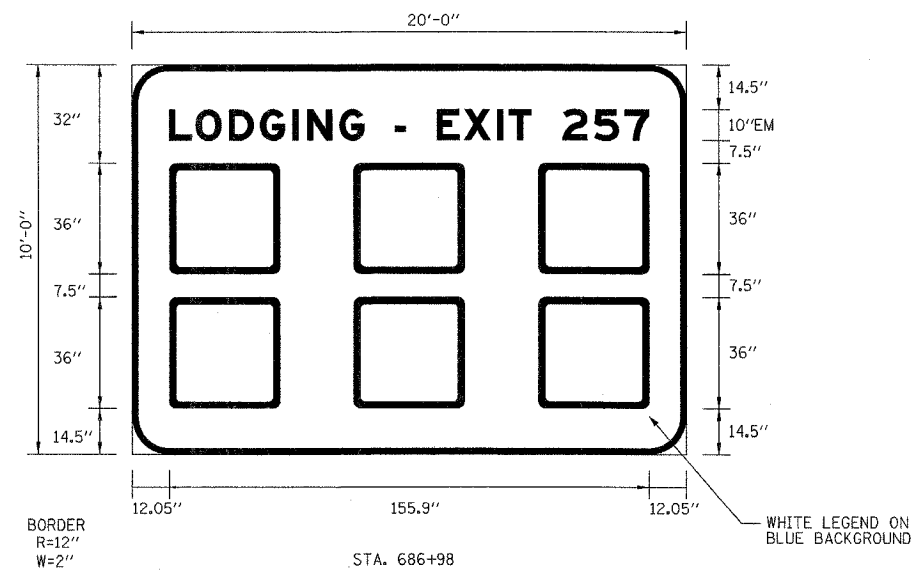
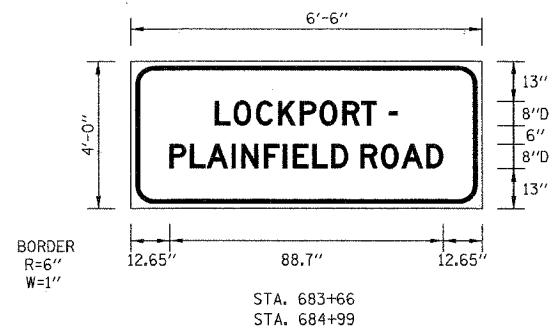
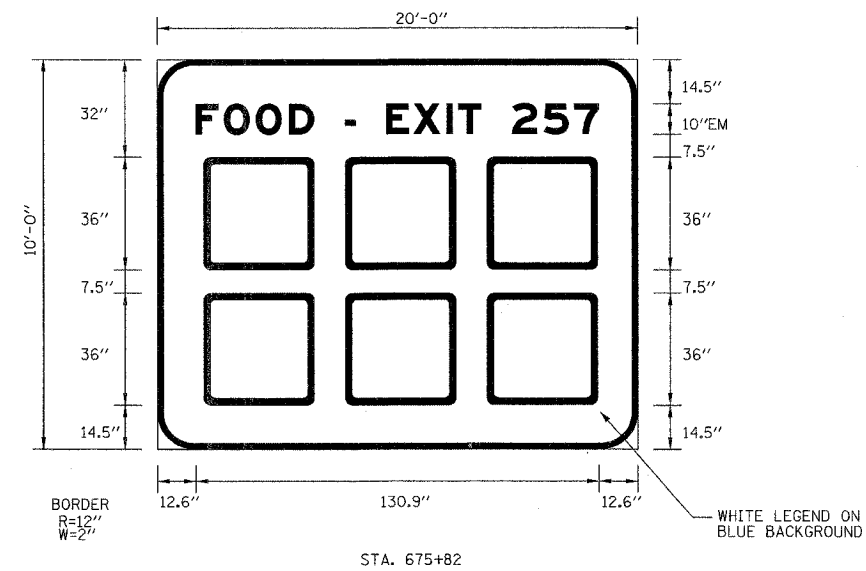
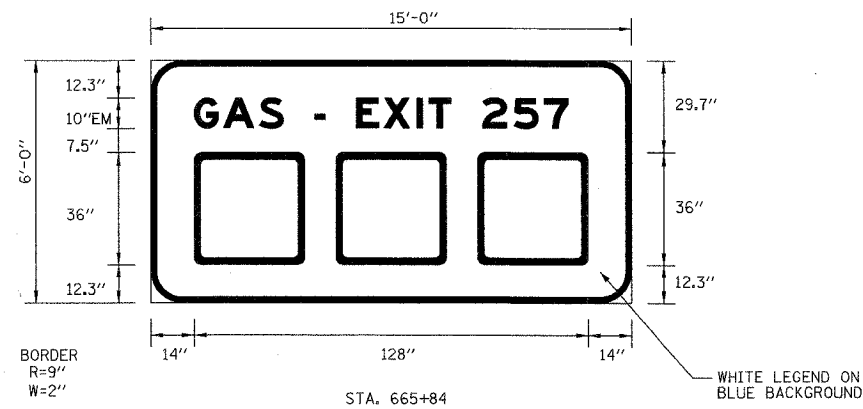

NOTE:
ALL SIGN PANELS SHALL HAVE
WHITE LEGEND, GREEN REFLECTORIZED
BACKGROUND UNLESS NOTED.



Civil Engineering
Structural Engineering
Surveying
446 E. Illinois, Suite 840
Chicago, IL 60611
(312) 942-9800

REVISIONS	
NAME	DATE

ILLINOIS DEPARTMENT OF TRANSPORTATION
F.A.I. I-55
US RTE. 30 TO 143rd STREET
SIGN PANEL DETAILS



SCALE:
DATE: FEBRUARY 23, 2007

DRAWN BY: JS, LC
CHECKED BY: SE

F.A.P. RTE.	SECTION	COUNTY	TOTAL SHEETS	SHEET NO.
55	100 (I&2)	I-9	227	122
STA.		TO STA.		
FED. ROAD DIST. NO.	ILLINOIS	FED. AID PROJECT		
DETL- 14 OF 27				

GROUND MOUNTED SIGN PANEL LAYOUT													
SIGN PANEL							SIGN POST						FOUNDATION
SIGN DESIGNATION	STATION	PANEL WIDTH (IN)	PANEL HEIGHT (IN)	PANEL AREA (SQ. FT.)	PANEL TYPE (EACH)	MILE MARKER (EACH)	POST TYPE	NUMBER OF POSTS	IN GROUND DEPTH (FT)	CLEAR HEIGHT (FT)	TOTAL LENGTH (FT)	WEIGHT (LB)	CONC. FND. (CU. YD.)
W4-1R	598+58 NB	48	48	16.00	2		WOOD	1	5	7	16		
E5-1a	598+69 SB	90	60	37.50	3		WOOD	2	5	7	20		
W13-3	601+55 SB	48	60	20.00	2		SIGN POLE						
SL TRUCKS	645+97 NB	48	96	32.00	3		WOOD	1	5	7	20		
GUIDE SIGN	655+85 SB	156	180	195.00	3		W10X22	2	6.5	7	28.5	1254.0	2.36
GUIDE SIGN	665+84 SB	180	72	90.00	3		W6X15	2	6	7	19	570.0	1.40
D10-3	669+02 SB	12	48	4.00		1	TELESCOPING	1	5	7	16		
D10-3	669+05 NB	12	48	4.00		1	TELESCOPING	1	5	7	16		
GUIDE SIGN	675+82 SB	240	120	200.00	3		W8X18	3	6	7	23	1242.0	2.10
W17-II01	683+66 NB	78	48	26.00	2		WOOD	2	5	7	16		
W17-II01	684+99 SB	78	48	26.00	2		WOOD	2	5	7	16		
GUIDE SIGN	686+98 SB	240	120	200.00	3		W8X18	2	6	7	23	828.0	1.40
R8-4	747+79 SB	48	36	12.00	2		WOOD	1	5	7	15		
TOTAL													
MILE POST MARKER ASSEMBLY						2							
SIGN PANEL TYPE 2				100.0									
SIGN PANEL TYPE 3				754.5									
STRUCTURAL STEEL SIGN SUPPORT - BREAKAWAY												3894.00	
TELESCOPING STEEL SIGN SUPPORT											32.0		
WOOD SIGN SUPPORT											103.0		
CONCRETE FOUNDATIONS												7.26	

CANTILEVER SIGN PANEL LAYOUT					
SIGN NUMBER	STATION	DESIGN TRUSS TYPE	CANTILEVER LENGTH (FT)	TOTAL SIGN AREA (SQ. FT.)	WALKWAY (FT)
1C099I055L257.7	601+55 SB	II-C-A	26	189.00	16
TOTAL					
SIGN PANEL TYPE 3				189.00	

NOTE:

IT HAS BEEN ESTIMATED THAT 50% OF THE EXISTING TYPE 3 SIGN PANEL POSTS WILL REMAIN IN PLACE AND BE RE-USED TO SUPPORT NEW PROPOSED SIGN PANELS. TYPE 3 SIGN PANEL POSTS THAT ARE IN GOOD CONDITION AND WILL SUPPORT THE PROPOSED SIGN PANELS IN A MANNER THAT MEETS THE APPROPRIATE STANDARDS AND SPECIFICATIONS SHALL BE RE-USED AS DETERMINED BY THE ENGINEER. IF REQUIRED, MODIFICATION OF THE SIGN POST SYSTEMS TO ACCOMMODATE THE PROPOSED SIGNS WILL BE INCLUDED IN THE COST OF THE RESPECTIVE SIGN PANEL.



DAVID MASON & ASSOCIATES
Civil Engineering
Structural Engineering
Surveying
445 E. Illinois, Suite 840
Chicago, IL 60611
(312) 942-9600

REVISIONS

NAME	DATE

ILLINOIS DEPARTMENT OF TRANSPORTATION
F.A.I. I-55
US RTE. 30 TO 143rd STREET

GROUND MOUNTED SIGN AND
CANTILEVER SIGN PANEL LAYOUT

SCALE: DATE: FEBRUARY 23, 2007

DRAWN BY: JS, LC
CHECKED BY: SE

CONTRACT NO. 62896				
F.A.P. RTE.	SECTION	COUNTY	TOTAL SHEETS	SHEET NO.
55	100 (I&2) I-9	WILL	227	123
STA.	TO STA.			
FED. ROAD DIST. NO.	ILLINOIS	FED. AID PROJECT		
DETL-15 OF 27				

GENERAL NOTES

DESIGN: AASHTO Standard Specifications for Structural Supports for Highway Signs, Luminaires and Traffic Signals. ("AASHTO Specifications")

CONSTRUCTION: Current (at time of letting) Illinois Department of Transportation Standard Specifications for Road and Bridge Construction, Supplemental Specifications and Special Provisions. ("Standard Specifications")

LOADING: 90 M.P.H. WIND VELOCITY

WALKWAY LOADING: Dead load plus 500 lbs. concentrated live load.

DESIGN STRESSES:

Field Units
 $f_c = 3,500$ p.s.i.
 $f_y = 60,000$ p.s.i. (reinforcement)

WELDING: All welds to be continuous unless otherwise shown. All welding to be done in accordance with current AWS D1.1 and D1.2 Structural Welding Codes (Steel and Aluminum) and the Standard Specifications.

MATERIALS: Aluminum Alloys as shown throughout plans. All Structural Steel Pipe shall be ASTM A53 Grade B with a minimum yield of 35,000 p.s.i., or A500 Grade B or C with a minimum yield of 46,000 p.s.i. If A500 pipe is substituted for A53, then the outside diameter shall be as detailed and wall thickness greater than or equal to A53.

All Structural Steel Plates and Shapes shall conform to AASHTO M270 Gr. 36, Gr. 50 or Gr. 50W*. Stainless steel for shims, sleeves and handhole covers shall be ASTM A240, Type 302 or 304, or another alloy suitable for exterior exposure and acceptable to the Engineer. The steel pipe and stiffening ribs of the base plate for the column shall have a minimum longitudinal Charpy V-Notch (CVN) energy of 15 lb.-ft. at 40° F. (Zone 2) before galvanizing.

FASTENERS FOR ALUMINUM TRUSSES: All bolts noted as "high strength" must satisfy the requirements of AASHTO M164 (ASTM A325), or approved alternate, and must have matching lock nuts. Threaded studs for splices (if Members interfere) must satisfy the requirements of ASTM A449, ASTM A193, Grade B7, or approved alternate, and must have matching lock nuts. Bolts and lock nuts not required to be high strength must satisfy the requirements of ASTM A307. All bolts and lock nuts must be hot dip galvanized per AASHTO M232. The lock nuts must have nylon or steel Inserts. A stainless steel flat washer conforming to ASTM A240 Type 302 or 304, is required under both head and nut or under both nuts where threaded studs are used. High strength bolt installation shall conform to Article 505.04 (f) (2) of the IDOT Standard Specifications for Road and Bridge Construction. Rotational capacity ("ROCAP") testing of bolts will not be required.

U-BOLTS AND EYEBOLTS: U-Bolts and Eyebolts must be produced from ASTM A276 Type 304, 304L, 316 or 316L, Condition A, cold finished stainless steel, or an equivalent material acceptable to the Engineer. All nuts for U-Bolts and Eyebolts must be lock nuts equivalent to ASTM A307 with nylon or steel Inserts and hot dip galvanized per AASHTO M232. A stainless steel flat washer conforming to ASTM A240, Type 302 or 304, is required under each U-Bolt and Eyebolt lock nut.

GALVANIZING: All Steel Grating, Plates, Shapes and Pipe shall be Hot Dip Galvanized after fabrication in accordance with AASHTO M111. Painting is not permitted.

ANCHOR RODS: Shall conform to AASHTO M314 Gr. 55 with a minimum Charpy V-Notch (CVN) energy of 15 lb.-ft. at 10° F.

CONCRETE SURFACES: All concrete surfaces above an elevation 6" below the lowest final ground line at each foundation shall be cleaned and coated with Bridge Seat Sealer in accordance with the Standard Specifications.

REINFORCEMENT BARS: Reinforcement Bars designated (E) shall be epoxy coated in accordance with the Standard Specifications.

* If M270 Gr. 50W (M222) steel is proposed, chemistry for plate to be used shall first be approved by the Engineer as suitable for galvanizing and welding.

Structure Number	Station	Design Truss Type	Cantilever Length (L)	Elev. A	Dim. D	D _s	Total Sign Area
1C0991055L257.7	60I+55	II-C-A	26	623.00	12.00	15.50	189.00 S.F.

Truss Type	Maximum Sign Area	Maximum Length
I-C-A	170 Sq. Ft.	25 Ft.
II-C-A	340 Sq. Ft.	30 Ft.
III-C-A	400 Sq. Ft.	40 Ft.

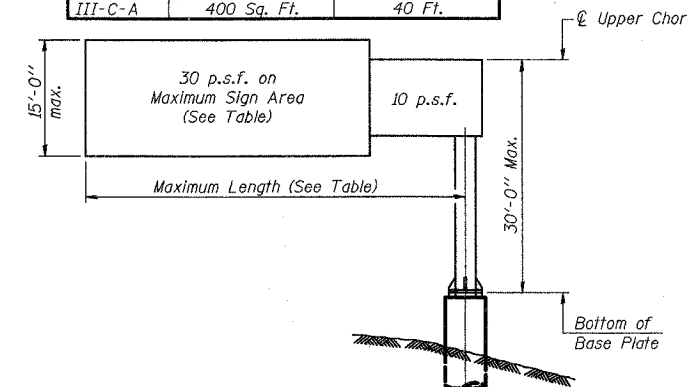

DESIGN WIND LOADING DIAGRAM

Parameters shown are basis for I.D.O.T. Standards
 Installations not within dimensional limits shown
 require special analysis for all components.

① After adjustments to level truss and insure adequate vertical clearance, all top and leveling nuts shall be tightened against the base plate with a minimum torque of 200 lb.-ft. Stainless steel mesh shall then be placed around the perimeter of the base plate. Secure to base plate with stainless steel banding.

Note:
 Trusses shall be shipped individually with adequate provision to prevent detrimental motion during transport. This may require ropes between horizontals and diagonals or energy dissipating (elastic) ties to the vehicle. The contractor is responsible for maintaining the configuration and protection of the trusses.

TOTAL BILL OF MATERIAL

ITEM	UNIT	TOTAL
OVERHEAD SIGN STRUCTURE CANTILEVER TYPE I-C-A	Foot	
OVERHEAD SIGN STRUCTURE CANTILEVER TYPE II-C-A	Foot	26.00
OVERHEAD SIGN STRUCTURE CANTILEVER TYPE III-C-A	Foot	
OVERHEAD SIGN STRUCTURE WALKWAY, TYPE A	Foot	16.00
DRILLED SHAFT CONCRETE FOUNDATIONS	Cu. Yds.	8.73

DAVID MASON & ASSOCIATES
 Civil Engineering
 Structural Engineering
 Surveying
 445 E. Illinois, Suite 640
 Chicago, IL 60611
 (312) 942-9600

PARSONS BRINCKERHOFF

REVISIONS	
NAME	DATE

OSC-A-1 I-7-05

ILLINOIS DEPARTMENT OF TRANSPORTATION
 F.A.I. I-55
 US RTE. 30 TO 143rd STREET
 CANTILEVER SIGN STRUCTURES
 GENERAL PLAN & ELEVATION
 ALUMINUM TRUSS & STEEL POST
 SCALE: DRAWN BY: JS, LC
 DATE: FEBRUARY 23, 2007 CHECKED BY: SE

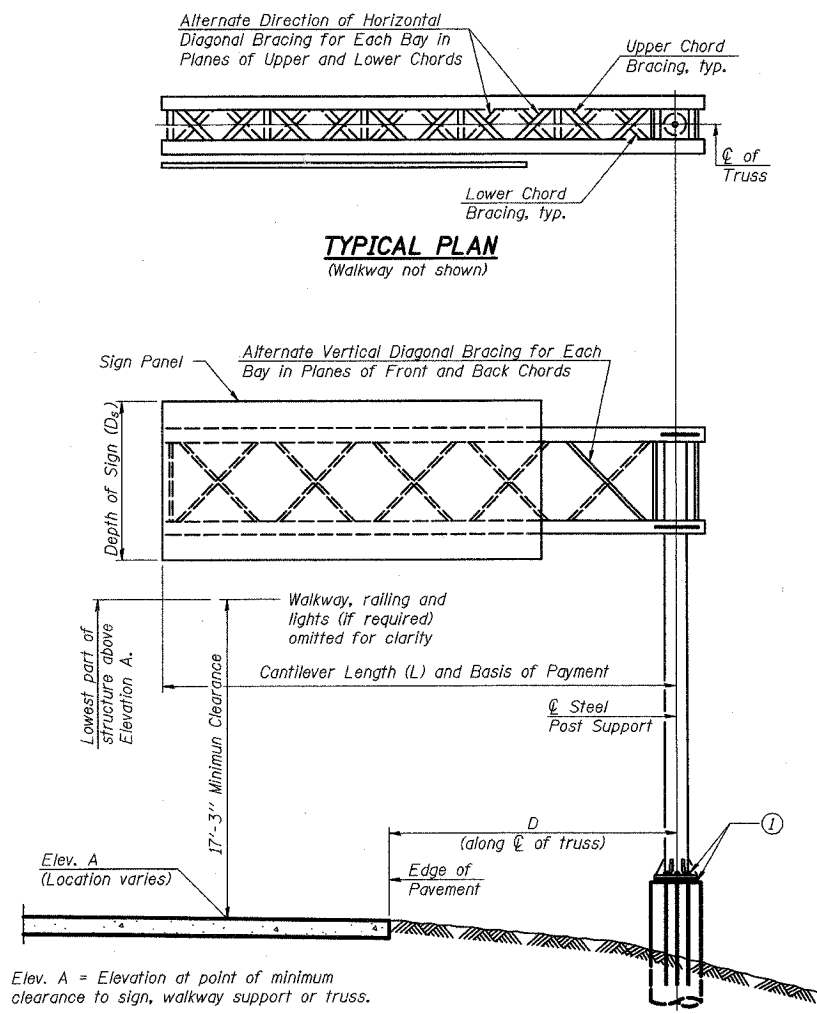

TYPICAL ELEVATION

Looking in Direction of Traffic

Sign support structures may be subject to damaging vibrations and oscillations when sign panels are not in place during erection or maintenance of the structure. To avoid these vibrations and oscillations, consideration should be given to attaching temporary blank sign panels to the structure.

NUMBER	REVISION	DATE

CONTRACT NO. 62896				
F.A.P. RTE.	SECTION	COUNTY	TOTAL SHEETS	SHEET NO.
55	100 (I&2) I-9	WILL	227	125
STA.		TO STA.		
FED. ROAD DIST. NO.	ILLINOIS	FED. AID PROJECT		
DETL5-17 OF 27				

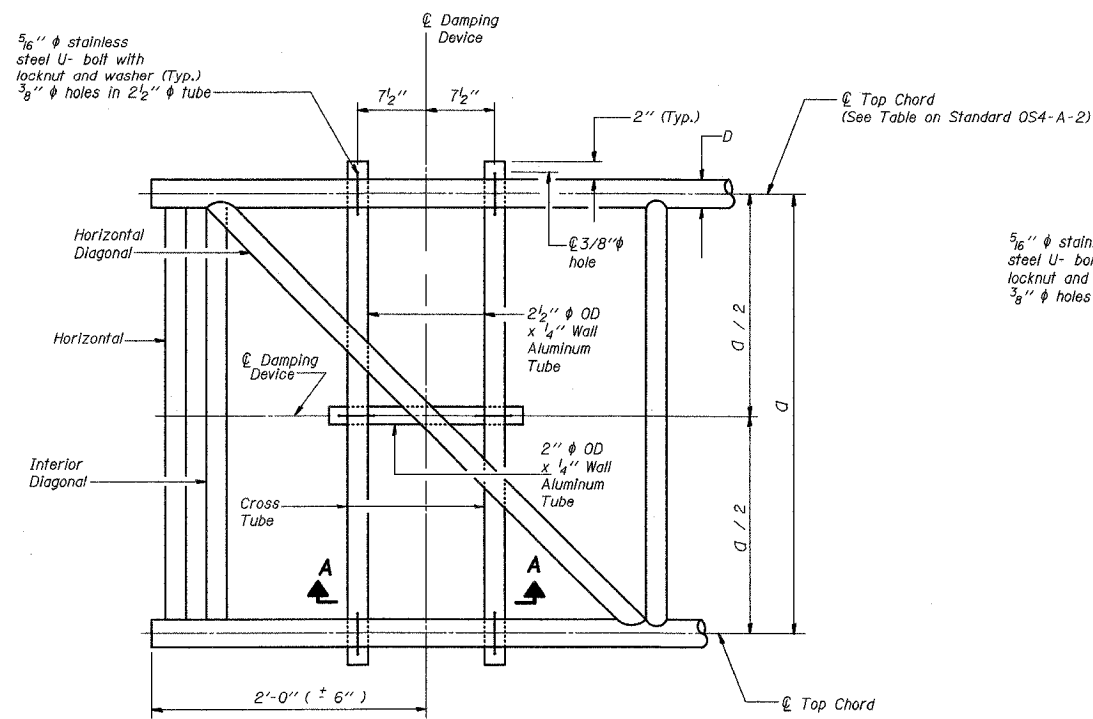

PLAN DETAIL

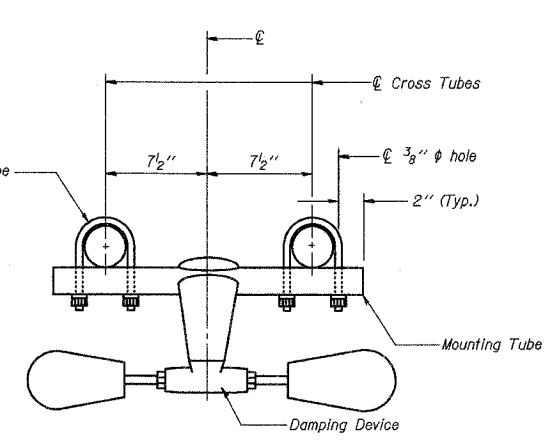

TRUSS DAMPING DEVICE CONNECTION DETAIL

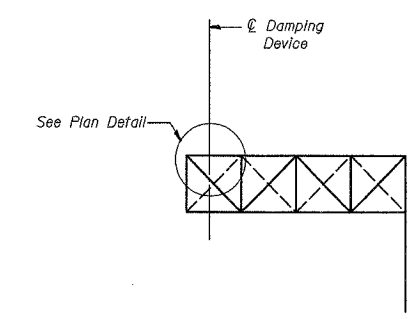

ELEVATION
Aluminum Cantilever Sign Structure

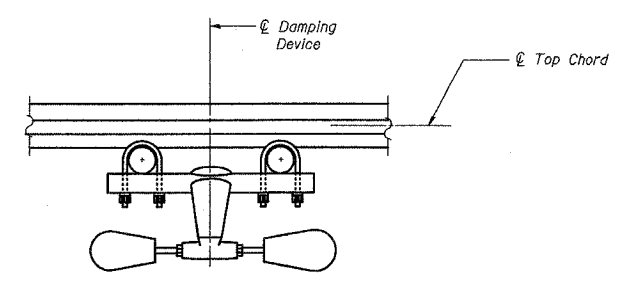

SECTION A-A

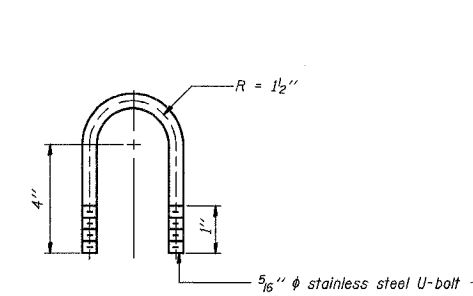

DAMPING DEVICE MOUNTING TUBE U-BOLT DETAIL
(Typical)

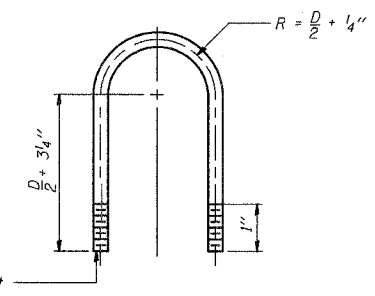

TOP CHORD TO CROSS TUBE U-BOLT DETAIL
(Typical)

GENERAL NOTES

- Damper: One damper per truss. (31 lbs. Stockbridge-Type Aluminum)
- Materials: Aluminum tubes shall be ASTM B221 alloy 6061 temper T6
- Fasteners: U-bolts shall be produced from ASTM A276 Type, 304, 304L, 316 or 316L, Condition A, cold finish, or an equivalent material acceptable to the Engineer. All nuts shall be stainless steel conforming to ASTM A194, Grade 8 (AISI 8 Type 304) or Grade 8F (AISI Type 303). The nuts shall be "locknuts" with nylon or steel inserts and semifinished hexagonal heads equivalent to the finished hex series of the American National Standards. All washers shall be stainless steel conforming to ASTM A240, Type 302 or 304.

DAVID MASON & ASSOCIATES
Civil Engineering
Structural Engineering
Surveying
445 E. Illinois, Suite 640
Chicago, IL 60611
(312) 942-9600

PB PARSONS BRINCKERHOFF

REVISIONS	
NAME	DATE

ILLINOIS DEPARTMENT OF TRANSPORTATION
F.A.I. I-55
US RTE. 30 TO 143rd STREET
CANTILEVER SIGN STRUCTURES
DAMPING DEVICE

SCALE: 1" = 50'
DATE: FEBRUARY 23, 2007

DRAWN BY: JS, LC
CHECKED BY: SE

CONTRACT NO. 62896				
F.A.P. RTE.	SECTION	COUNTY	TOTAL SHEETS	SHEET NO.
55	100 (I&2) I-9	WILL	227	126
STA.	TO STA.			
FED. ROAD DIST. NO.	ILLINOIS	FED. AID PROJECT		
DETL-18 OF 27				

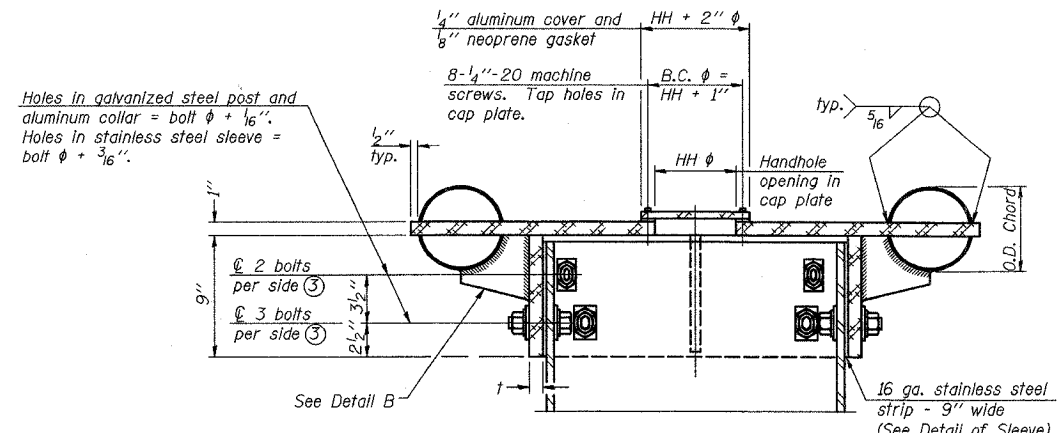

④ Collar I.D. shall be manufactured to correspond to O.D. of actual galvanized post and stainless steel sleeve plus 1/8 inch (± 1/16 inch). Maximum gap between post and collar at any location equals 1/8 inch before tightening bolts.

SECTION B-B
Bolts, washers (including contoured washers), and locknuts shall be stainless steel.

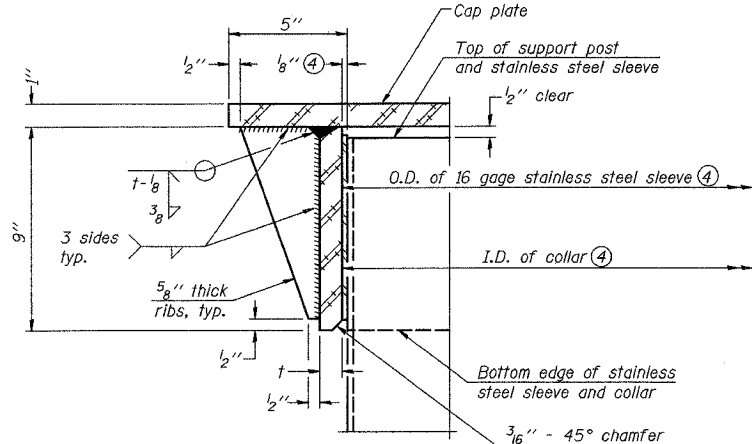

DETAIL A
(Two locations)
3/16 inch - 45° chamfer on inside of collar to facilitate field assembly

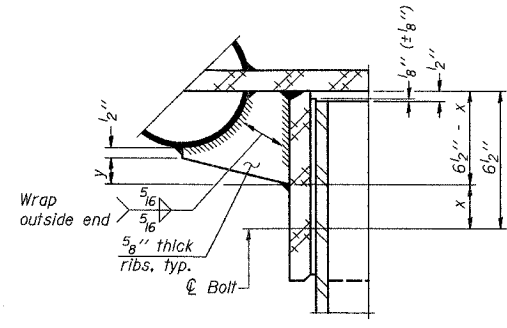

DETAIL B
Two locations
(For details not shown, see Detail C)

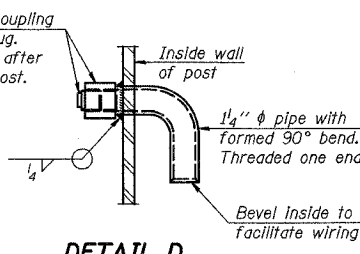

DETAIL D

DETAIL OF STAINLESS STEEL SLEEVE

Weld to post after galvanizing.
(Prepare post surface to insure tight, uniform fit and allow welding.)
Welds to be 1/2 inch long at 6 inch cts. along top edge and at 1/4 inch opening.

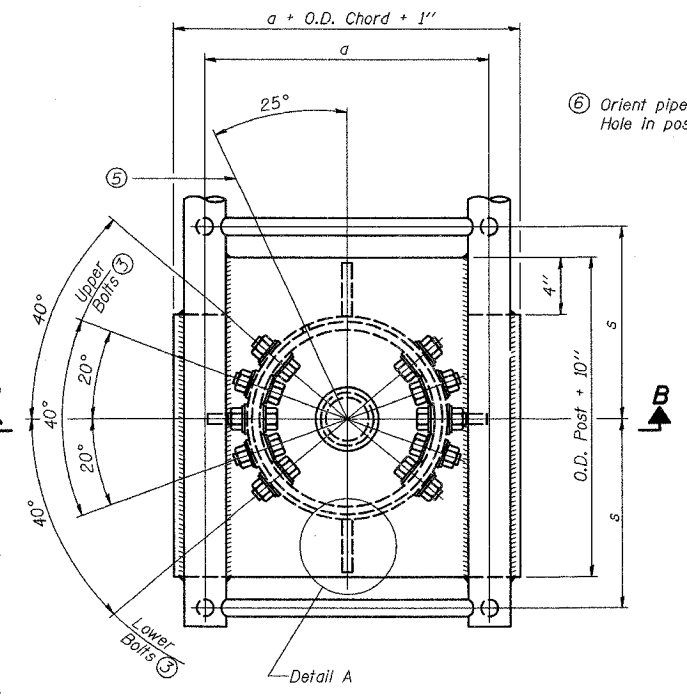

PLAN VIEW - TOP OF COLUMN
⑤ Optional full penetration weld in collar.
(Two locations maximum... (180° apart)... X-ray or UT 100%)

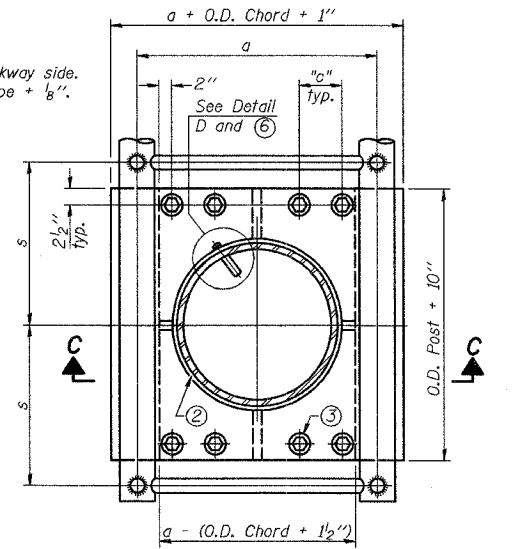

SECTION THRU POST ABOVE LOWER CHORDS

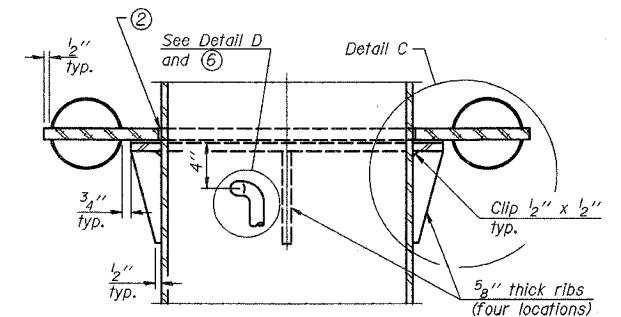

SECTION C-C

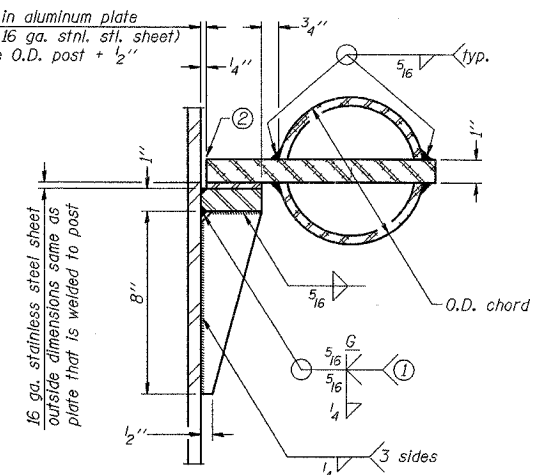

DETAIL C

- ① Grind top if required to fully seat aluminum plate and stainless steel sheet.
- ② After tightening lower connection bolts, fill gap with non-hardening, silicone caulk suitable for exterior exposure and acceptable to the Engineer. Cost is included in Overhead Sign Structure Cantilever.

CONTOURED WASHERS

Bolt Size	Contoured Washers	
	Hole Dia.	B
7/8"	1"	2 1/2"
1"	1 1/8"	3"
1 1/4"	1 3/8"	3 1/4"

Truss Type	Post Size	Upper & Lower Connection Bolt Diameter ③	Lower Juncture Bolt Spacing Dimension "c" ③	Opening in Cap Plate "HH"	Collar Thickness (t)	Side Ribs	
						x	y
I-C-A	16" phi (B3#/1)	7/8"	3 1/4"	8"	5/8"	1 3/4"	2 1/4"
II-C-A	24" phi (125#/1)	1"	3 1/2"	12"	7/8"	2"	1 1/4"
III-C-A (35' max.)	24" phi (125#/1)	1 1/4"	3 1/2"	12"	7/8"	2"	1"
III-C-A (>35' to 40')	24" phi (171#/1)	1 1/4"	3 1/2"	12"	7/8"	2"	1"

③ Upper and lower connection bolts in collar and bolts at lower chord connection shall be high strength with matching locknuts. Connection bolts shall have 2 stainless steel flat washers each.

NUMBER	REVISION	DATE

DAVID MASON & ASSOCIATES
Civil Engineering
Structural Engineering
Surveying
445 E. Illinois, Suite 640
Chicago, IL 60611
(312) 942-9606

PARSONS BRINCKERHOFF

REVISIONS	
NAME	DATE

ILLINOIS DEPARTMENT OF TRANSPORTATION
F.A.I. I-55
US RTE. 30 TO 143rd STREET
CANTILEVER SIGN STRUCTURES
JUNCTURE DETAILS
ALUMINUM TRUSS & STEEL POST
SCALE: DRAWN BY: JS, LC
DATE: FEBRUARY 23, 2007 CHECKED BY: SE

F.A.P. RTE.	SECTION	COUNTY	TOTAL SHEETS	SHEET NO.
55	100 (1&2)	I-9	227	127
STA.		TO STA.		
FED. ROAD DIST. NO.		ILLINOIS FED. AID PROJECT		
DETL-19 OF 27				

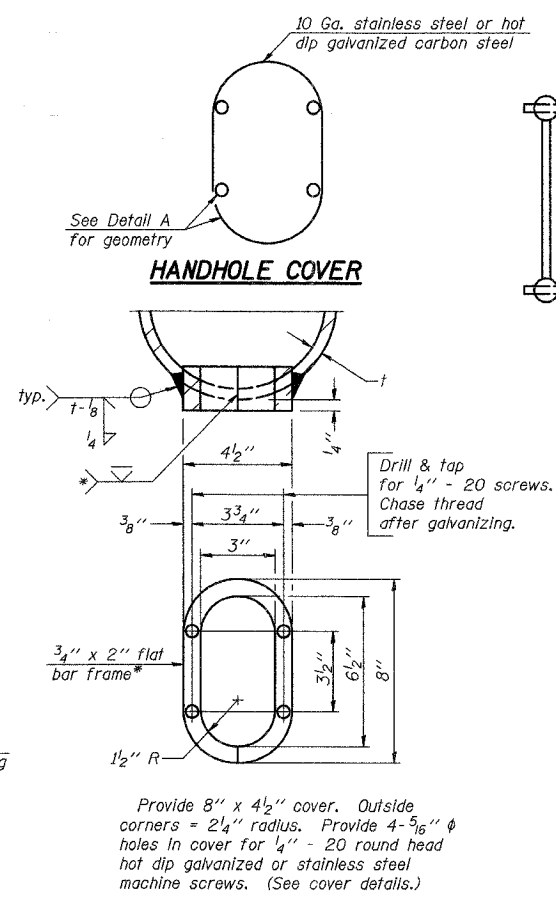
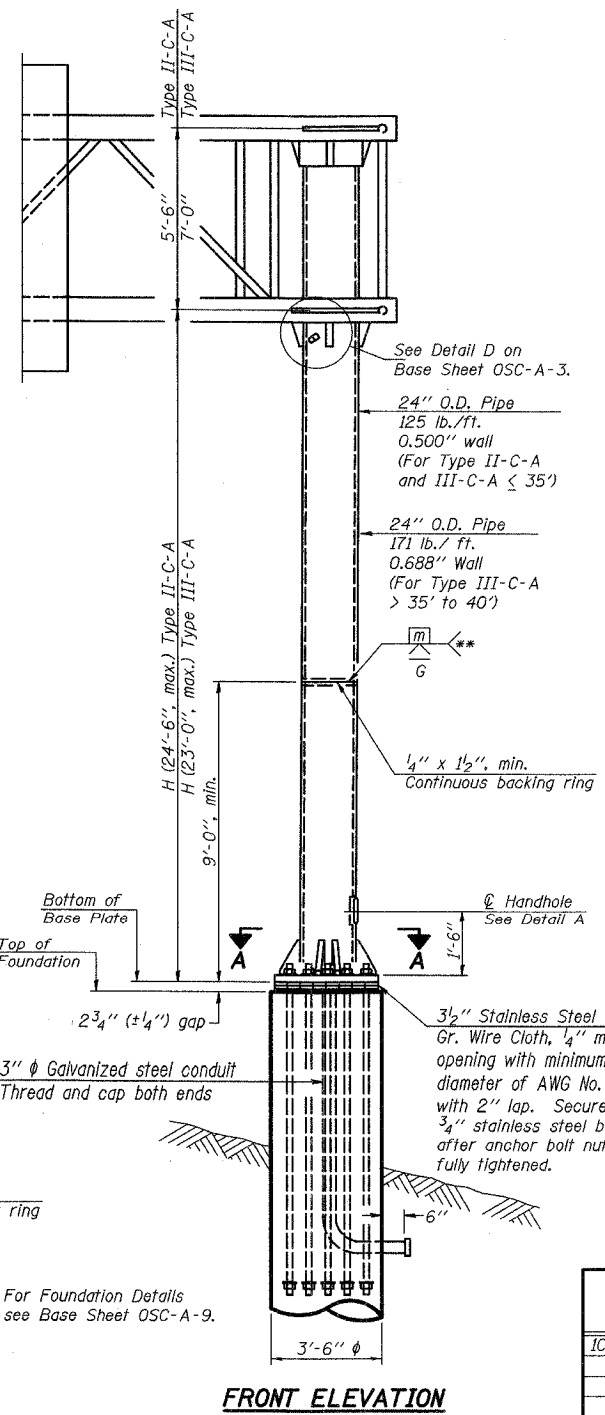
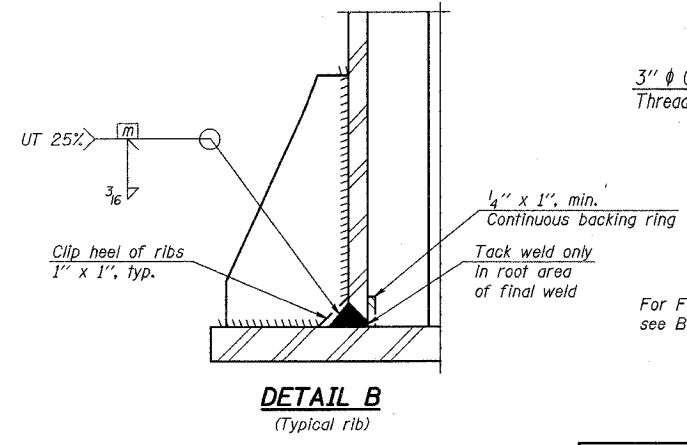
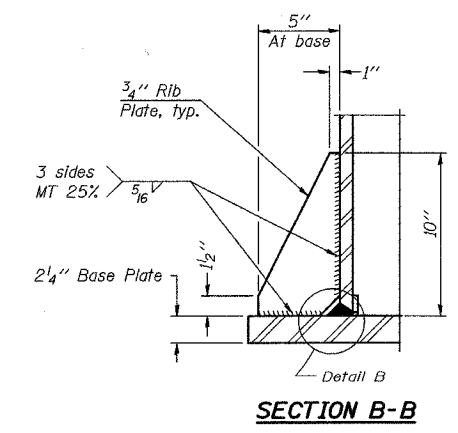
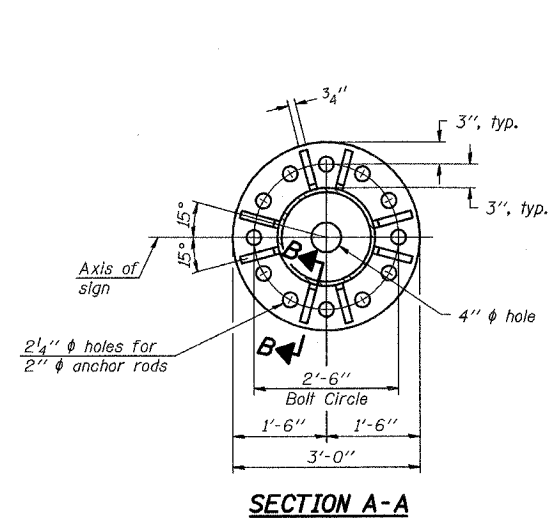

DETAIL A

- * Bent bars may be butt welded top and bottom or bottom only. In lieu of fabricated handhole frame as shown, may cut from 2" plate (rolling direction vertical). All cut faces to be ground to ANSI Roughness of 500 min or less.
- ** Butt welded joint in post is only allowed for post heights (H) over 20 ft. in length. If used, weld procedure must be preapproved by Engineer and joint shall receive 100% RT or UT (tension criteria) at Contractor's expense.

Structure Number	Station	H
1C0991055L257.7	601+55	23'-9"

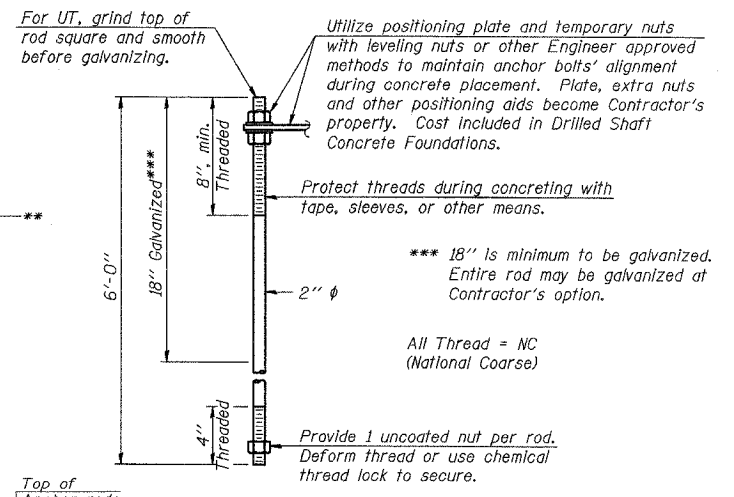
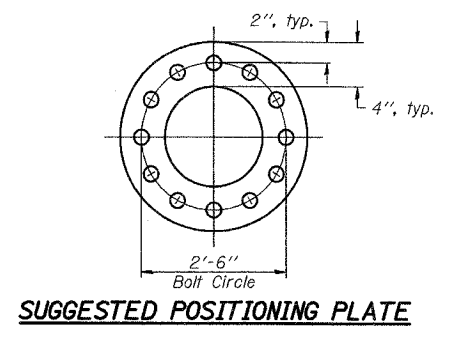
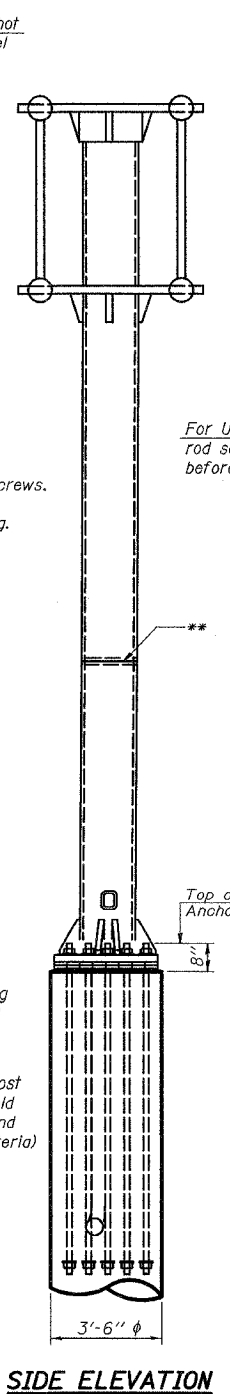

ANCHOR ROD DETAIL

Anchor rods shall conform to AASHTO M314 Grade 55 and meet Charpy V-Notch (CVN) energy of 15 lb.-ft. at 10° F. before galvanizing. Galvanize the upper 18" (minimum) and associated M291, Grade A, C or DH heavy hex nuts and hardened washers per AASHTO M232. No welding shall be permitted on rods. Provide an unfinished nut at bottom, a hexagon locknut and washer above base plate and a leveling nut and washer below base plate. Nuts shall each be tightened with 200 lb.-ft. minimum torque against base plate. Before or after threading, but before galvanizing, each anchor rod shall be ultrasonically tested (UT) by a Level II or III inspector, qualified in accord with ANSI guidelines, using a straight beam, 1/2" diameter 3.5 mhz. transducer, to insure no rejectable flaws exist in the upper 18" (tension criteria). Cost of testing Included in Drilled Shaft Concrete Foundations.

**CANTILEVER SIGN STRUCTURES
TYPE II-C-A & III-C-A TRUSS SUPPORT POST
ALUMINUM TRUSS & STEEL POST**

NUMBER	REVISION	DATE

DAVID MASON & ASSOCIATES
Civil Engineering
Structural Engineering
Surveying
446 E. Illinois, Suite 640
Chicago, IL 60611
(312) 943-9600

PARSONS BRINCKERHOFF

REVISIONS	
NAME	DATE

OSC-A-5 I-7-05

ILLINOIS DEPARTMENT OF TRANSPORTATION
F.A.I. I-55
US RTE. 30 TO 143rd STREET

CANTILEVER SIGN STRUCTURES
TYPE II-C-A & III-C-A TRUSS SUPPORT POST
ALUMINUM TRUSS & STEEL POST

SCALE: DRAWN BY: JS, LC
DATE: FEBRUARY 23, 2007 CHECKED BY: SE

CONTRACT NO. 62896				
F.A.P. RTE.	SECTION	COUNTY	TOTAL SHEETS	SHEET NO.
55	100 (I&2) I-9	WILL	227	128
STA.		TO STA.		
FED. ROAD DIST. NO.		ILLINOIS FED. AID PROJECT		
DETL-20 OF 27				

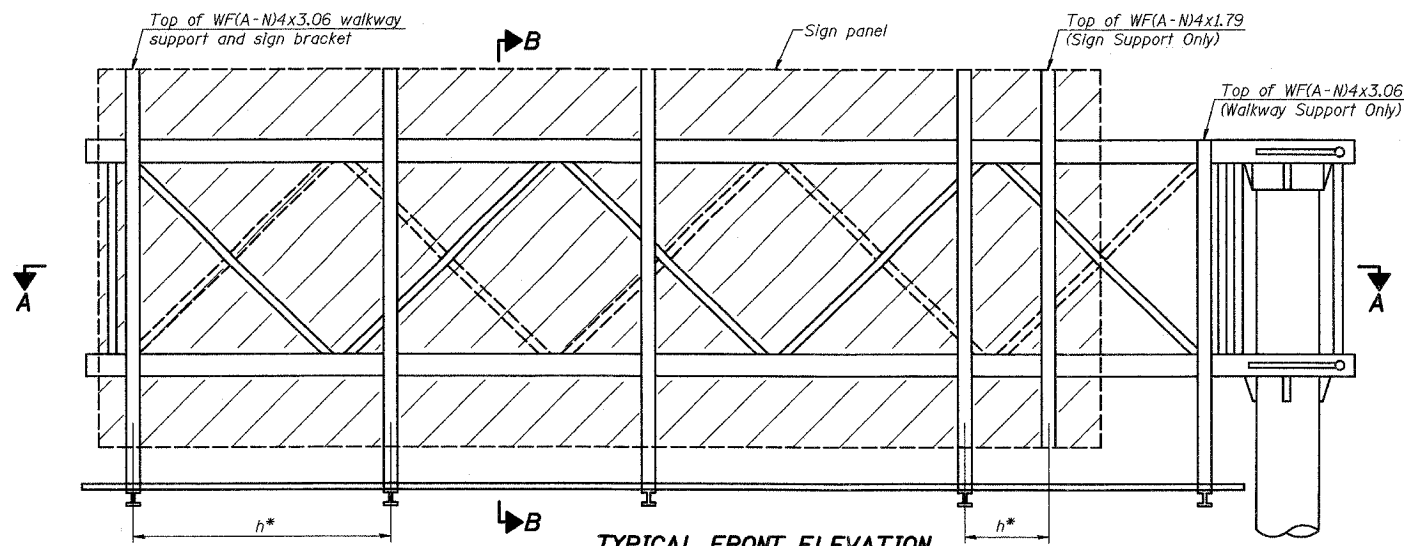

TYPICAL FRONT ELEVATION
With lights and handrail omitted for clarity.

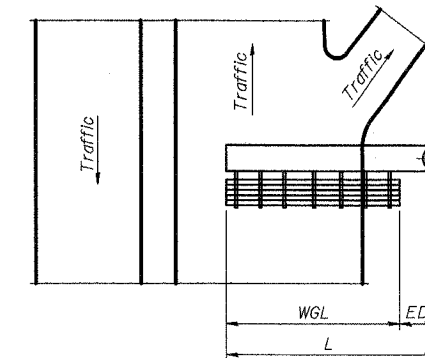

PLAN WALKWAY AND HANDRAIL SKETCH
(Road plan beneath truss varies)

Walkway and truss grating dimensions are nominal and may vary (width ± 1/2", depth ± 1/2") based on available standard widths.

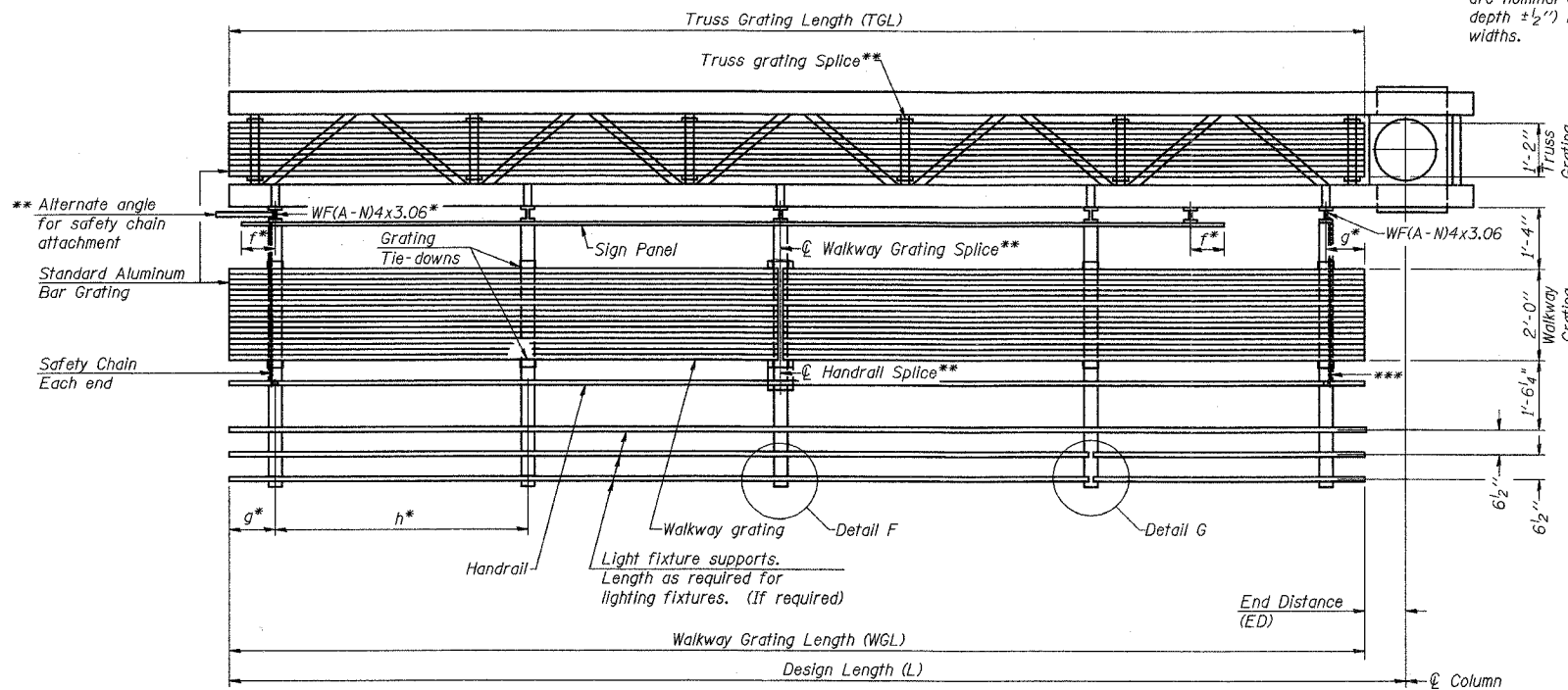

SECTION A-A

Truss grating to facilitate inspection shall run full length of cantilevers. Cost of truss grating is included in Overhead Sign Structure Cantilever.

Handrail and walkway grating shall span a minimum of three brackets between splices. ** Use and location of handrail or grating splices are optional, based on lengths needed and material availability.

$$TGL = L - \left(\frac{\text{Post O.D.}}{2} + 6'' \right)$$

NUMBER	REVISION	DATE

Structure Number	Station	WGL	ED	TGL
IC0991055L257.7	601+55	16'	10'	24'-6"

Notes:
 * Space walkway brackets WF(A-N)4x3.06 and sign brackets WF(A-N)4x1.79 for efficiency and within limits shown:
 f = 12" maximum, 4" minimum (End of sign to center of nearest bracket)
 g = 12" maximum, 4" minimum (End of walkway to center of nearest bracket)
 h = 6'-0" maximum (center to center of sign and/or walkway support brackets, WF(A-N)4x1.79 or WF(A-N)4x3.06)
 *** If walkway bracket at safety chain location is behind sign, add angle to bracket.
 For details of sign placement, sign/walkway brackets, truss and walkway gratings, grating splices and Section B-B, see Base Sheet OSC-A-7.
 For details of handrail, handrail splice, safety chain and Details F and G, see Base Sheet OSC-A-8.

BRACKET TABLE

WF(A-N)4x1.79 or WF(A-N)4x3.06 ASTM B308, Alloy 6061-T6		
Sign Width	Number Brackets Required	
Greater Than	Less Than or Equal To	
8'-0"	8'-0"	2
14'-0"	14'-0"	3
20'-0"	20'-0"	4
26'-0"	26'-0"	5
32'-0"	32'-0"	6

DAVID MASON & ASSOCIATES
 Civil Engineering
 Structural Engineering
 Surveying
 445 E. Illinois, Suite 640
 Chicago, IL 60611
 (312) 942-9999

PARSONS BRINCKERHOFF

REVISIONS	
NAME	DATE

OSC-A-6

1-7-05

ILLINOIS DEPARTMENT OF TRANSPORTATION
 F.A.I. 1-55
 US RTE. 30 TO 143rd STREET
 CANTILEVER SIGN STRUCTURES
 ALUMINUM WALKWAY DETAILS
 ALUMINUM TRUSS & STEEL POST

SCALE: DRAWN BY: JS, LC
 DATE: FEBRUARY 23, 2007 CHECKED BY: SE

FINAL

F.A.P. RTE.	SECTION	COUNTY	TOTAL SHEETS	SHEET NO.
55	100 (1&2)	I-9	WILL	227
STA. TO STA.			129	
FED. ROAD DIST. NO.		ILLINOIS	FED. AID PROJECT	
DETL-21 OF 27				

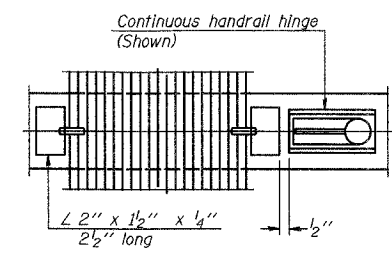
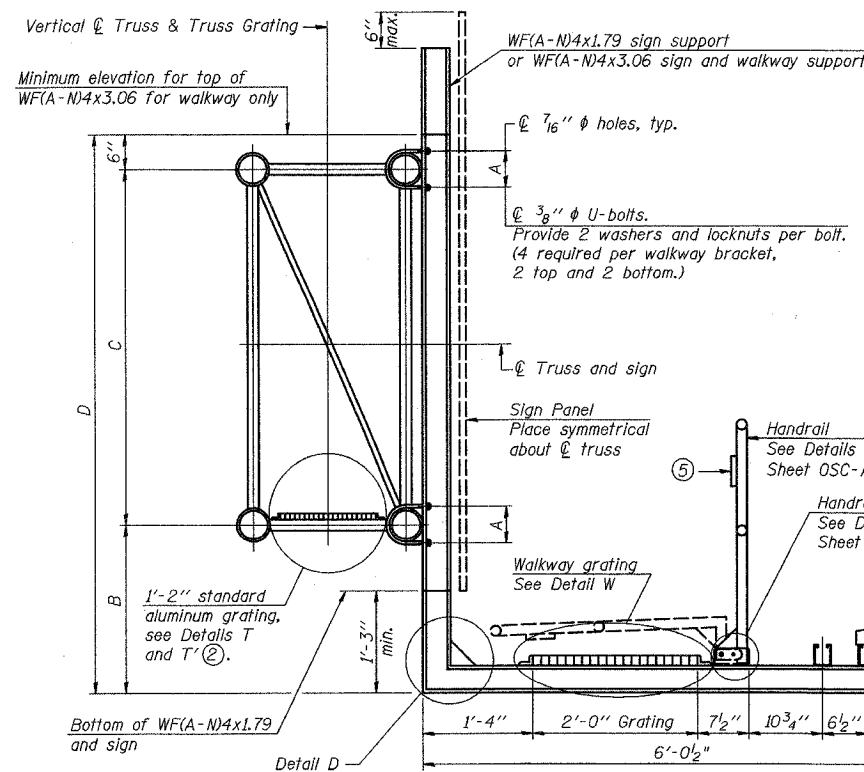

(CONTINUOUS WALKWAY GRATING)

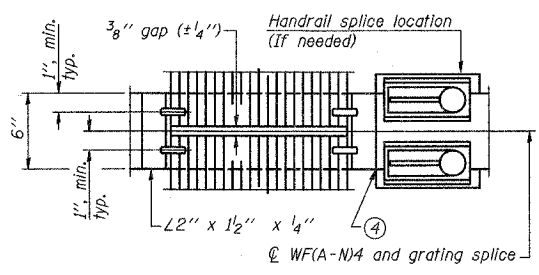

SECTION W-W (AT WALKWAY GRATING SPLICE)

SPECIFICATIONS FOR STANDARD ALUMINUM GRATING

Main Bearing Bars (MBB) shall be 3/16" x 1 1/2" on 1 3/16" centers and conform to ASTM B211 Alloy 6061-T6.
 Cross bars (CB) shall be 3/16" x 1 1/2" on 4" centers and conform to ASTM B211 Alloy 6063-T5 or 6061-T6.

OR

Aluminum Grating with modified "4" sections for main bearing bars shall meet the following requirements:
 Main bars shall conform to ASTM B211 Alloy 6061-T6 and have a minimum section modulus equal to 0.0705 in.³ per bar, a depth of 1 1/2", spaced on 1 3/16" centers.
 Cross bars shall conform to ASTM B211 Alloy 6063-T5 or T-42 and spaced on 4" centers.

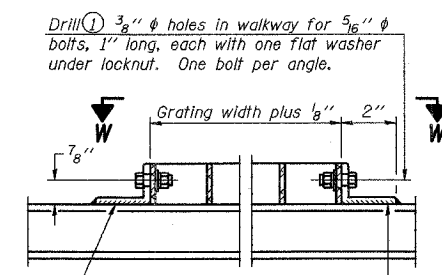

DETAIL W (Walkway grating)

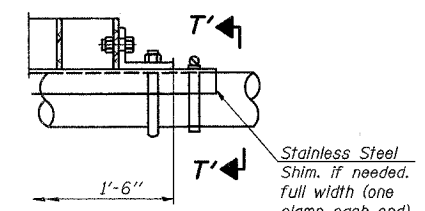

DETAIL T' (Truss grating splice)

Details not shown same as Detail T. Alternate materials may be used subject to the Engineer's review and approval.

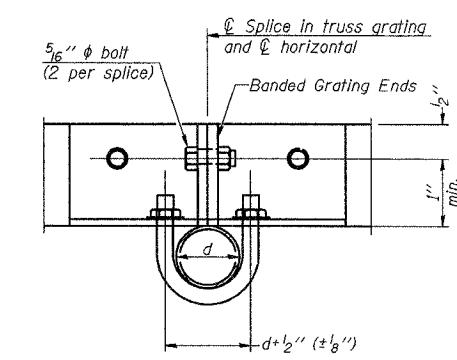

SECTION T'-T'

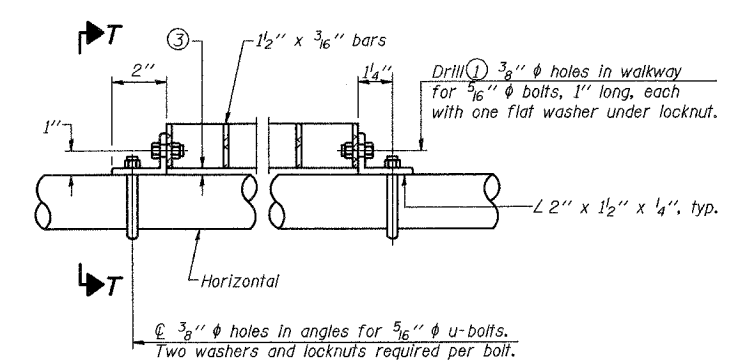

DETAIL T (Truss grating at horizontal)

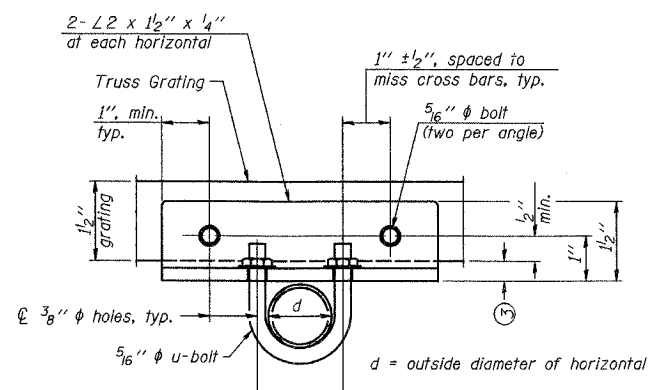

SECTION T-T

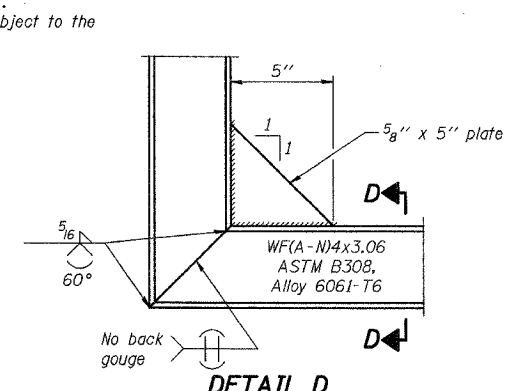

DETAIL D (See Detail P, Base Sheet OSC-A-8.)

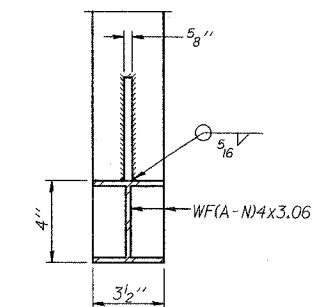

SECTION D-D

NUMBER	REVISION	DATE

Structure Number	Station	A	B	C	D
IC0991055L257.7	601+55	7 1/8"	6'-3"	5'-6"	12'-3"

- Drilling holes in grating may be done in shop or field, based on Contractor's preference and subject to accurate alignment.
- When truss grating must be spliced, use suggested detail or other methods subject to the Engineer's review and approval. Locate splice to avoid interference between cross bars and bolt locations.
- Tube to grating gap may vary from 0 to 1/2", max. to align walkway, allow for camber, etc.
- If Handrail Joint present, weld angle to WFA-N)4 and 1/4" extension bars. (See Base Sheet OSC-A-8)
- ϕ 1/2" x 1/2" x 2" welded to handrail posts to protect locations that contact grating.

DAVID MASON & ASSOCIATES
 Civil Engineering
 Structural Engineering
 Surveying
 446 N. Illinois, Suite 610
 Chicago, IL 60611
 (312) 940-9000

PARSONS BRINCKERHOFF

REVISIONS	
NAME	DATE

OSC-A-7 1-7-05
 ILLINOIS DEPARTMENT OF TRANSPORTATION
 F.A.I. I-55
 US RTE. 30 TO 143rd STREET
 CANTILEVER SIGN STRUCTURES
 WALKWAY DETAILS
 ALUMINUM TRUSS & STEEL POST
 SCALE: DRAWN BY: JS, LC
 DATE: FEBRUARY 23, 2007 CHECKED BY: SE

F.A.P. RTE.	SECTION	COUNTY	TOTAL SHEETS	SHEET NO.
55	100 (I&2) I-9	WILL	227	130
STA.		TO STA.		
FED. ROAD DIST. NO.		ILLINOIS FED. AID PROJECT		
DETS-22 OF 27				

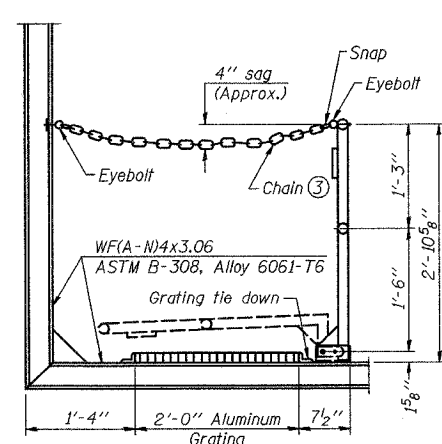

SIDE ELEVATION
(Showing Safety Chain W/O Sign)

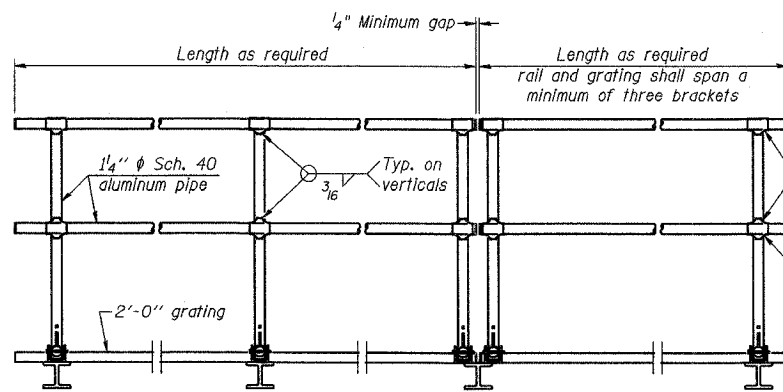

FRONT ELEVATION

HANDRAIL DETAILS

Handrail pipe shall be ASTM B241, Alloy 6063-T6 or Alloy 6061-T6.

① Install standard force-fit end caps or weld 1/8" end plates with 1/8" c.f.w. and grind smooth. (All rail ends)

② Horizontal handrail member shall be continuous thru fitting. Provide 7/16" hole in fitting for 3/8" bolt. Field drill 1/16" hole in horizontal rail member. Provide locknut and two stainless steel washers for bolt. (Use 5/16" eyebolts in 7/16" holes on top rail at ends only.)

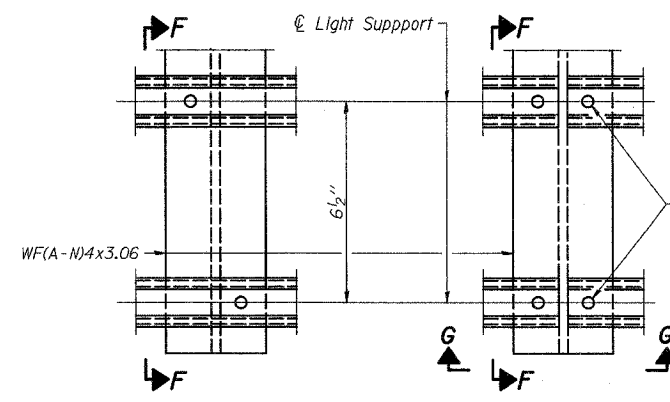

DETAIL F

DETAIL G

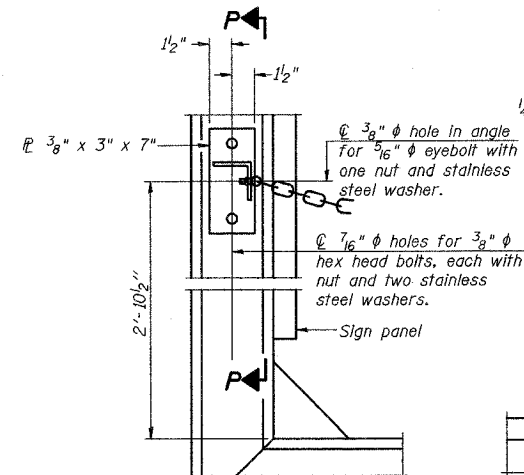

ALTERNATE SAFETY CHAIN ATTACHMENT
(With Sign Present)

Items not shown same as "Side Elevation" of "Handrail Details"

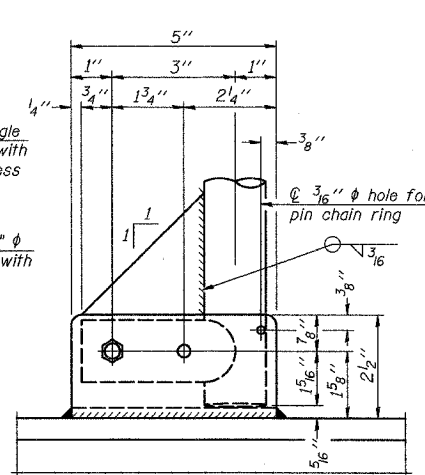

SIDE ELEVATION

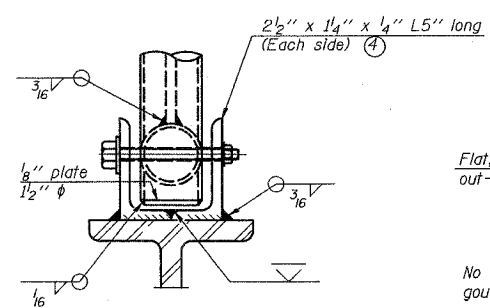

FRONT ELEVATION

Details not shown same as "ELEVATION" at right.

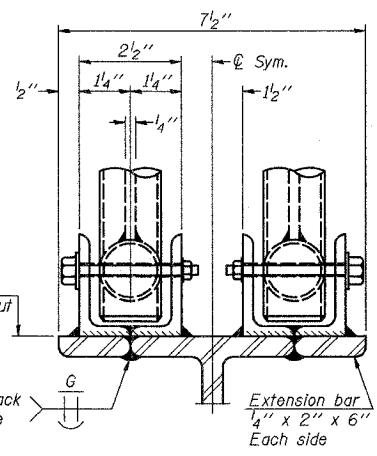

ELEVATION AT HANDRAIL JOINT

Details not shown same as "FRONT ELEVATION"

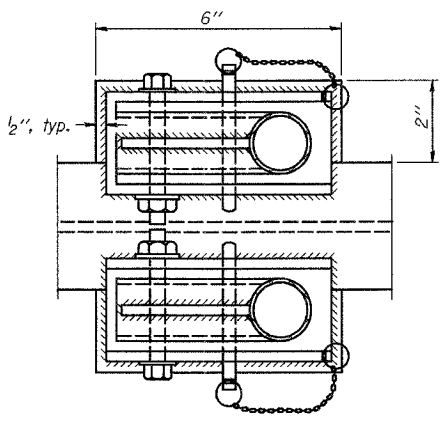

PLAN AT HANDRAIL JOINT

Details not shown same as "PLAN"

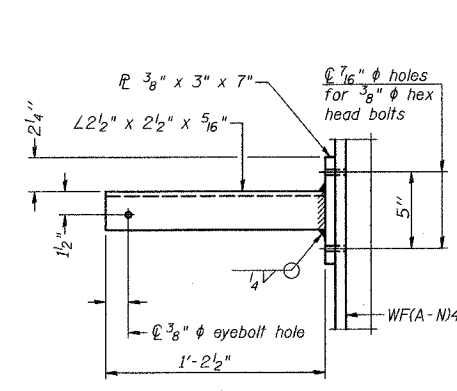

SECTION P-P

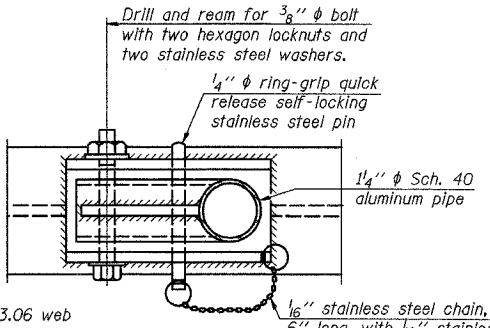

DETAIL E HANDRAIL HINGE

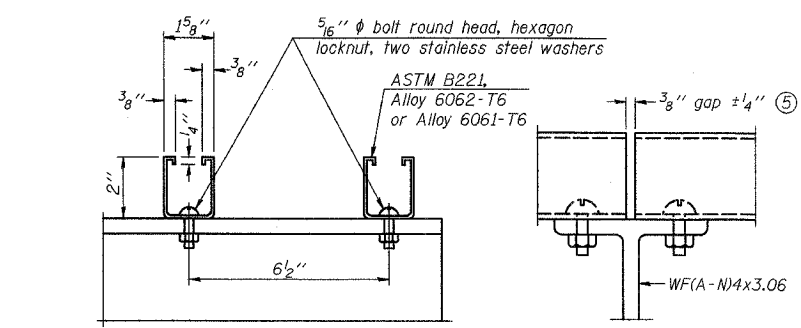

SECTION F-F

SECTION G-G

LIGHTING FIXTURE MOUNTS (IF REQUIRED)

⑤ Field cut ends of light support channels shall be free of burrs or hazardous projections and coated with zinc-rich primer or equivalent.

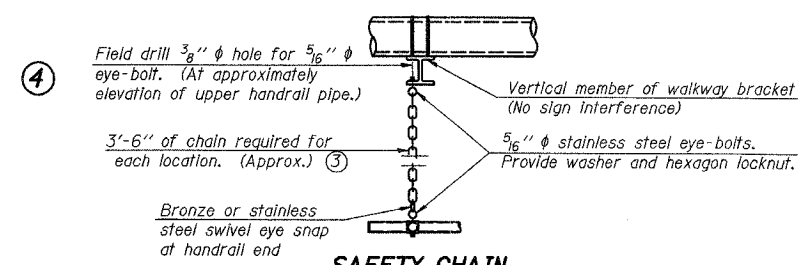

SAFETY CHAIN

One required for each end of each walkway.

ALTERNATE SAFETY CHAIN ATTACHMENT

Details not shown similar to "Safety Chain" Details (Walkway omitted for clarity)

⑤ 3/16" galvanized steel chain, approximately 12 links per foot. Chain to be hot dip galvanized after manufacture and suitable for prolonged exterior exposure. Alternate materials may be substituted with the Engineer's approval.

④ Extrusions may be used in lieu of the details shown, with approval of the Engineer.

NUMBER	REVISION	DATE

DAVID MASON ASSOCIATES
Civil Engineering
Structural Engineering
Surveying
245 E. Illinois, Suite 640
Chicago, IL 60611
(312) 942-9600

PARSONS BRINCKERHOFF

REVISIONS	
NAME	DATE

OSC-A-8 I-7-05
ILLINOIS DEPARTMENT OF TRANSPORTATION
F.A.I. I-55
US RTE. 30 TO 143rd STREET
CANTILEVER SIGN STRUCTURES
HANDRAIL DETAILS
ALUMINUM TRUSS & STEEL POST
SCALE: DRAWN BY: JS, LC
DATE: FEBRUARY 23, 2007 CHECKED BY: SE

F.A.P. RTE.	SECTION	COUNTY	TOTAL SHEETS	SHEET NO.
55	100 (I&2) I-9	WILL	227	131
STA.	TO STA.			
FED. ROAD DIST. NO.	ILLINOIS	FED. AID PROJECT	DETLS- 23 OF 27	

* Grind anchor rod to bright finish at ground clamp location before installing clamp.

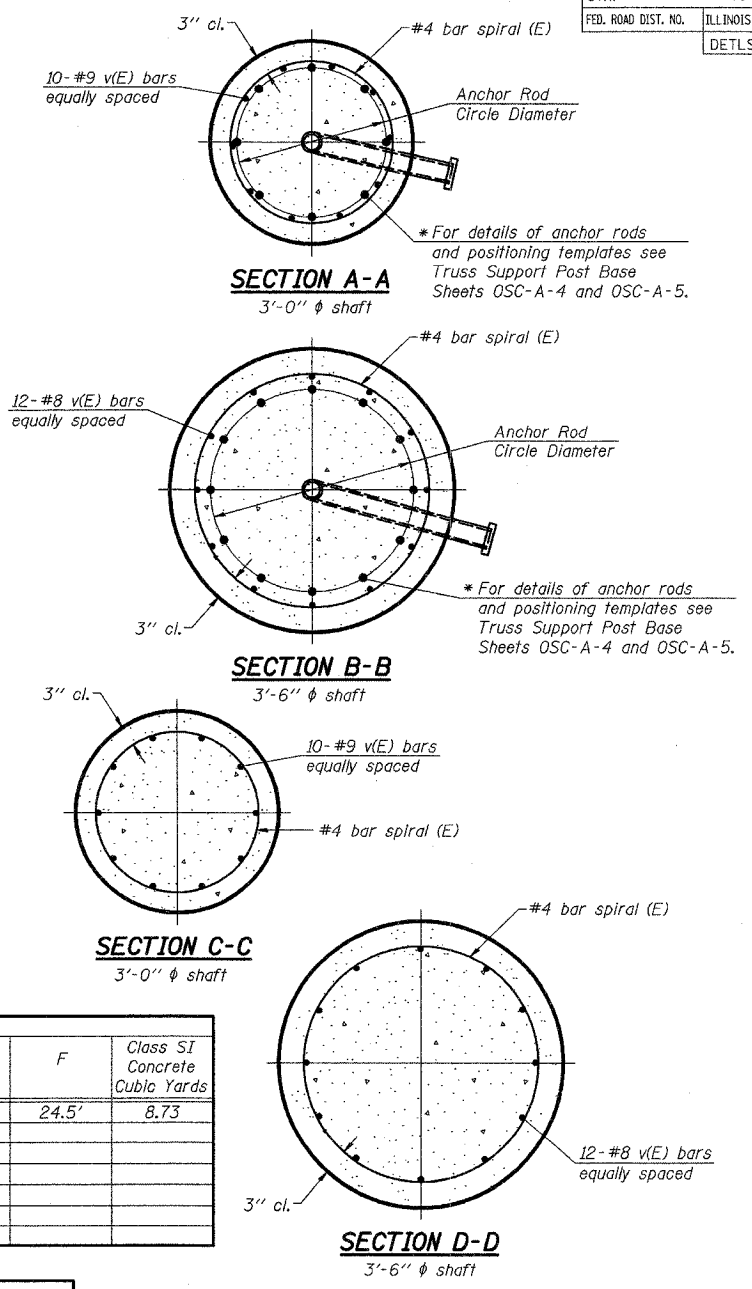
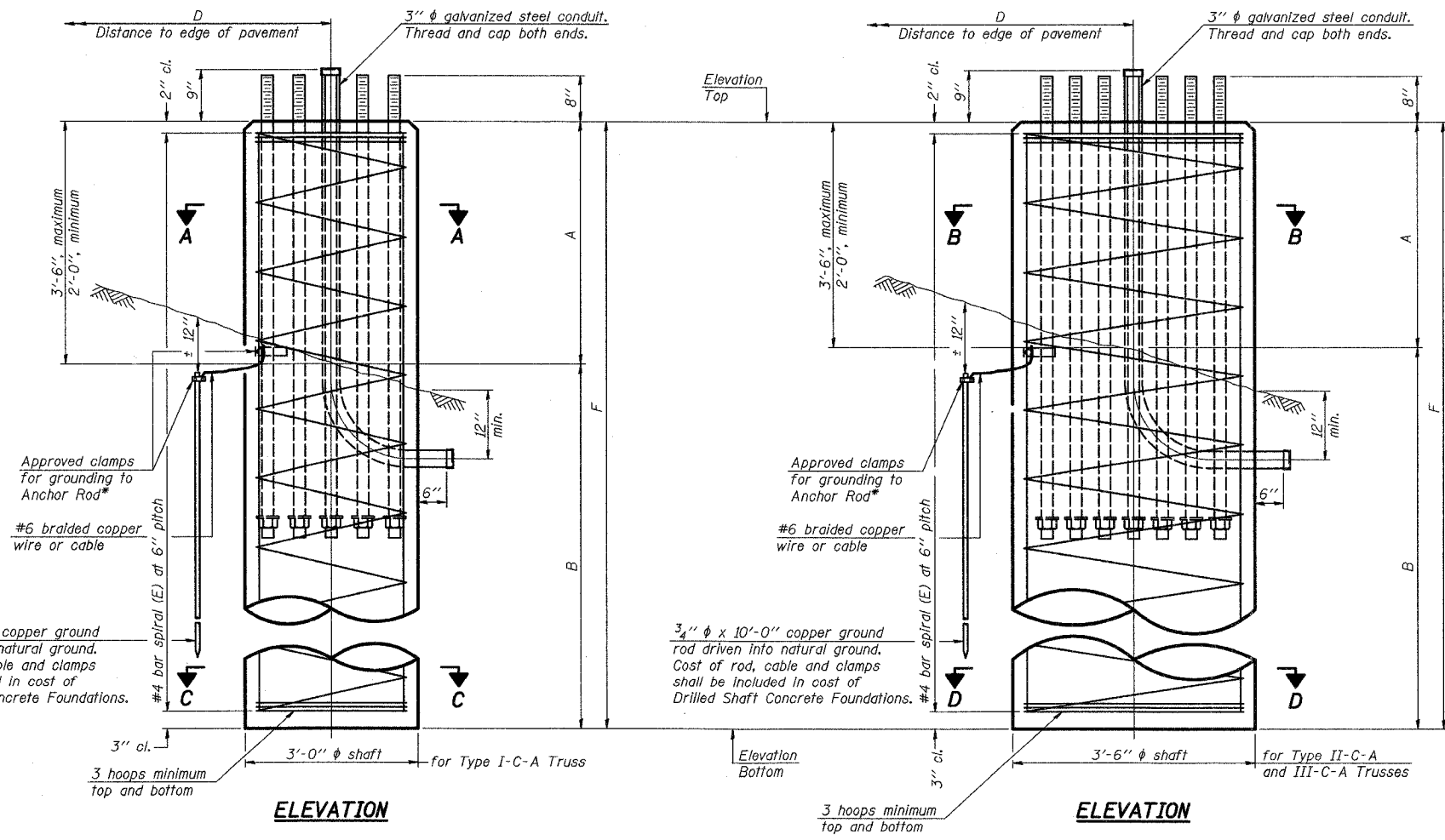

NOTES:
 The foundation dimensions shown in the Foundation Design Table are based on the presence of mostly cohesive soils with an average Unconfined Compressive Strength (Qu) of at least 1.25 tsf, which must be determined by previous soil investigations at the jobsite. When other conditions are indicated, the boring data will be included in the plans and the foundation dimensions shown in the Foundation Data Table will be the result of site specific designs.
 If the conditions encountered are different than those indicated, the Contractor shall notify the Engineer to determine if the Foundation dimensions need to be modified. If dimensions "B" or "F" are revised by more than 12" by the Contractor, "as-built" plans shall be prepared and submitted to the District Bureau of Operations for future reference.
 No sonotubes or decomposable forms shall be used below the lower conduit entrance. Permanent metal forms or other shielding may not be left in place below that elevation without the Engineer's written permission.
 Concrete shall be placed monolithically, without construction joints.
 Backfill shall be placed per Article 502 of Standard Specification and prior to erection of support column.
 A normal surface finish followed by a Bridge Seat Sealer application will be required on concrete surfaces above the lowest elevation 6" below finished ground line. Cost included in "Drilled Shaft Concrete Foundation".

Structure Number	Station	Truss Type	Shaft Diameter	Elevation Top	Elevation Bottom	Qu	A	B	F	Class SI Concrete Cubic Yards
IC0991055L257.7	601+55	II-C-A	3.5	623.00	598.5	≥ 1.25 TSF	2'	22.5	24.5'	8.73

Truss Type	Post Base Sheet	Maximum Cantilever Length (ft)	Maximum Total Sign Area (sq ft)	Shaft Diameter (in)	"B" Depth (ft)	Anchor Rods		Anchor Rod Circle Diameter (in)
						No.	Diameter (in)	
I-C-A	OSC-A-4	25	170	3.0	16.0	8	2	22
II-C-A	OSC-A-5	30	170	3.5	17.0	12	2	30
II-C-A	OSC-A-5	30	340	3.5	21.5	12	2	30
III-C-A	OSC-A-5	35	170	3.5	19.0	12	2	30
III-C-A	OSC-A-5	35	250	3.5	22.5	12	2	30
III-C-A	OSC-A-5	35	400	3.5	26.5	12	2	30
III-C-A	OSC-A-5	40	400	3.5	32.0	12	2	30

NUMBER	REVISION	DATE

DAVID MASON & ASSOCIATES
 Civil Engineering Structural Engineering Surveying
 440 E. Illinois, Suite 640
 Chicago, IL 60611
 (312) 942-9600

PARSONS BRINCKERHOFF

NAME	DATE

OSC-A-9 1-7-05
 ILLINOIS DEPARTMENT OF TRANSPORTATION
 F.A.I. I-55
 US RTE. 30 TO 143rd STREET
 CANTILEVER SIGN STRUCTURES
 DRILLED SHAFT
 ALUMINUM TRUSS & STEEL POST

SCALE: DRAWN BY: JS, LC
 DATE: FEBRUARY 23, 2007 CHECKED BY: SE

F.A.P. RTE.	SECTION	COUNTY	TOTAL SHEETS	SHEET NO.
55	100 (I&2) I-9	WILL	227	133
STA.		TO STA.		
FED. ROAD DIST. NO.		ILLINOIS FED. AID PROJECT		
DETL-25 OF 27				

POST	CONCRETE FOUNDATION TABLE						POST TO STUB POST CONNECTION DATA										FUSE PLATE DATA					
	Foundation		Reinforcement			Stub Post Length	Bolt Size	A	B	C	D	E	t ₁	t ₂	R	W	J	K	L	t ₃		
	Diameter	Minimum Depth	Concrete (cu. yds.)	Vertical Bars Length	Bar Spirals Diameter Length																lbs. (2)	
W6x9	2'-0"	6'-0"	0.70	5'-9"	1'-8 1/2"	79'-0"	78	2'-3"	5/8" x 3 1/4"	6"	2 1/4"	1 1/4"	3 1/2"	1 1/4"	3/4"	1/2"	1 1/2"	1/4"	4"	2 1/4"	7/8"	1/4"
W6x15	2'-0"	6'-0"	0.70	5'-9"	1'-8 1/2"	79'-0"	78	2'-6"	5/8" x 3 1/4"	6"	2 1/4"	1 1/4"	3 1/2"	1 1/4"	3/4"	1/2"	1 1/2"	1/4"	6"	3 1/2"	1 1/4"	3/8"
W8x18	2'-0"	6'-0"	0.70	5'-9"	1'-8 1/2"	79'-0"	78	2'-6"	3/4" x 3 3/4"	6"	2 1/2"	1 3/8"	3 1/4"	1 3/8"	1"	1/2"	1 3/2"	5/16"	5 1/4"	2 3/4"	1 1/4"	3/8"
W10x22	2'-6"	6'-6"	1.18	6'-3"	2'-2 1/2"	105'-0"	92	3'-0"	3/4" x 3 3/4"	6"	2 1/2"	1 3/8"	3 1/4"	1 3/8"	1"	1/2"	1 3/2"	5/16"	5 3/4"	2 3/4"	1 1/2"	1/2"
W10x26	2'-6"	7'-0"	1.27	6'-9"	2'-2 1/2"	112'-0"	98	3'-0"	7/8" x 4"	7"	2 3/4"	1 1/2"	4"	1 1/2"	1"	3/4"	5/32"	3/8"	5 3/4"	2 3/4"	1 1/2"	5/8"
W12x26	2'-6"	7'-9"	1.41	7'-6"	2'-2 1/2"	119'-0"	107	3'-0"	7/8" x 4"	7"	2 3/4"	1 1/2"	4"	1 1/2"	1"	3/4"	5/32"	3/8"	6 1/2"	3 1/2"	1 1/2"	5/8"
W14x30	3'-0"	7'-3"	1.90	7'-0"	2'-8 1/2"	145'-0"	113	3'-0"	7/8" x 4"	7"	2 3/4"	1 1/2"	4"	1 1/2"	1"	3/4"	5/32"	3/8"	6 3/4"	3 1/2"	1 5/8"	1/2"
W14x38	3'-0"	8'-0"	2.09	7'-9"	2'-8 1/2"	153'-0"	122	3'-6"	1" x 4 1/2"	7 1/2"	3"	1 3/4"	4"	1 1/2"	1"	3/4"	11/32"	3/8"	6 3/4"	3 1/2"	1 5/8"	1/2"
W16x45	3'-0"	8'-6"	2.23	8'-3"	2'-8 1/2"	162'-0"	130	3'-6"	1" x 4 1/2"	7 1/2"	3"	1 3/4"	4"	1 3/4"	1"	3/4"	11/32"	3/8"	7"	3 1/2"	1 3/4"	1/2"

*Dimensional changes required for varying site conditions shall be approved by the Engineer.

POST	FUSE PLATE BOLT SIZE												
	Sign Depth												
	4'-0"	5'-0"	6'-0"	7'-0"	8'-0"	9'-0"	10'-0"	11'-0"	12'-0"	13'-0"	14'-0"	15'-0"	16'-0"
W6x9	1/2" x 1 1/2"	1/2" x 1 1/2"	1/2" x 1 1/2"	5/8" x 1 3/4"	5/8" x 1 3/4"	5/8" x 1 3/4"	---	---	---	---	---	---	---
W6x15	1/2" x 1 3/4"	1/2" x 1 3/4"	5/8" x 2"	5/8" x 2"	3/4" x 2"	3/4" x 2"	3/4" x 2"	3/4" x 2"	7/8" x 2"	7/8" x 2"	---	---	---
W8x18	1/2" x 1 3/4"	1/2" x 1 3/4"	5/8" x 2"	5/8" x 2"	3/4" x 2"	3/4" x 2"	7/8" x 2 1/4"	7/8" x 2 1/4"	7/8" x 2 1/4"	7/8" x 2 1/4"	7/8" x 2 1/4"	7/8" x 2 1/4"	7/8" x 2 1/4"
W10x22	1/2" x 2"	1/2" x 2"	5/8" x 2"	5/8" x 2"	3/4" x 2 1/4"	3/4" x 2 1/4"	7/8" x 2 1/4"	7/8" x 2 1/4"	7/8" x 2 1/4"	1" x 2 1/2"	1" x 2 3/4"	1" x 2 3/4"	1" x 2 3/4"
W10x26	1/2" x 2"	1/2" x 2"	5/8" x 2 1/4"	5/8" x 2 1/4"	3/4" x 2 1/2"	3/4" x 2 1/2"	7/8" x 2 1/2"	7/8" x 2 1/2"	1" x 2 3/4"	1" x 2 3/4"	1" x 2 3/4"	1 1/8" x 3"	---
W12x26	---	---	---	---	5/8" x 2 1/4"	---	---	7/8" x 2 1/2"	7/8" x 2 1/2"	1" x 2 1/2"	1" x 2 3/4"	1" x 2 3/4"	1" x 2 3/4"
W14x30	1/2" x 2"	1/2" x 2"	5/8" x 2"	5/8" x 2"	3/4" x 2 1/4"	3/4" x 2 1/4"	7/8" x 2 1/4"	7/8" x 2 1/4"	7/8" x 2 1/4"	1" x 2 1/2"	1" x 2 3/4"	1" x 2 3/4"	1" x 2 3/4"
W14x38	---	1/2" x 2"	5/8" x 2"	5/8" x 2"	3/4" x 2 1/4"	3/4" x 2 1/4"	7/8" x 2 1/4"	7/8" x 2 1/4"	7/8" x 2 1/4"	1" x 2 1/2"	1" x 2 3/4"	1" x 2 3/4"	1" x 2 3/4"
W16x45	---	---	5/8" x 2"	5/8" x 2"	3/4" x 2 1/4"	3/4" x 2 1/4"	7/8" x 2 1/4"	7/8" x 2 1/4"	7/8" x 2 1/4"	1" x 2 1/2"	1" x 2 3/4"	1" x 2 3/4"	1" x 2 3/4"

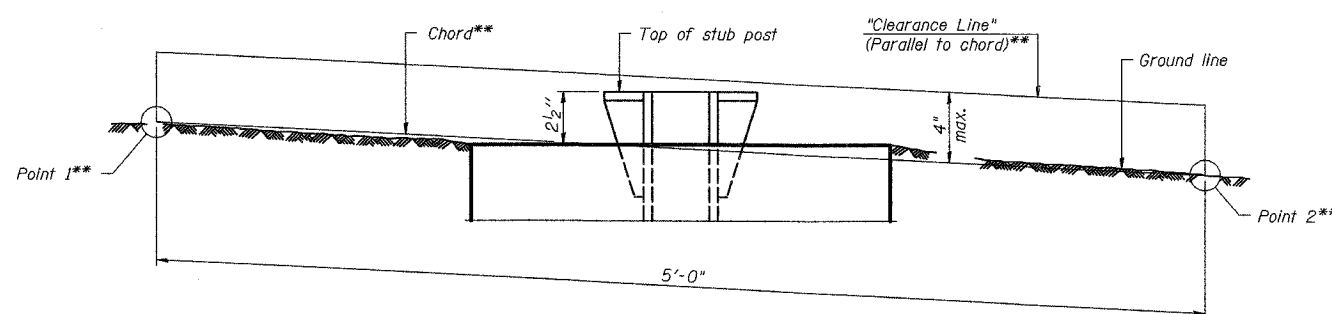

**ELEVATION
GROUND LINE & STUB POST**

** For all "Point 1" and "Point 2" locations, "Clearance Line" must be at or above top of stub post.

- ① Quantity includes all concrete necessary for one foundation.
- ② Includes reinforcement bars and spiral hooping for one foundation.

NUMBER	REVISION	DATE

DAVID MASON & ASSOCIATES
Civil Engineering
Structural Engineering
Surveying
445 E. Illinois, Suite 640
Chicago, IL 60611
(312) 942-9600

PB PARSONS BRINCKERHOFF

REVISIONS	
NAME	DATE

BAW-A-2 1-7-05
ILLINOIS DEPARTMENT OF TRANSPORTATION
F.A.I. I-55
US RTE. 30 TO 143rd STREET
BREAK-AWAY WIDE FLANGE
STEEL SIGN POST TABLES
SCALE: DRAWN BY: JS, LC
DATE: FEBRUARY 23, 2007 CHECKED BY: SE

F.A. RTE.	SECTION	COUNTY	TOTAL SHEETS	SHEET NO.
55			227	134
STA.		TO STA.		
FED. ROAD DIST. NO.		ILLINOIS FED. AID PROJECT		

- THE DIAGONAL LINES SHALL BE SPACED AT 12M (40') C-C ACROSS ALL STRUCTURES WHICH ARE 150M (500') OR LESS IN LENGTH
- THE DIAGONAL LINES ARE NOT REQUIRED ON SHOULDERS WHICH ARE 1.8M (6') OR LESS IN WIDTH

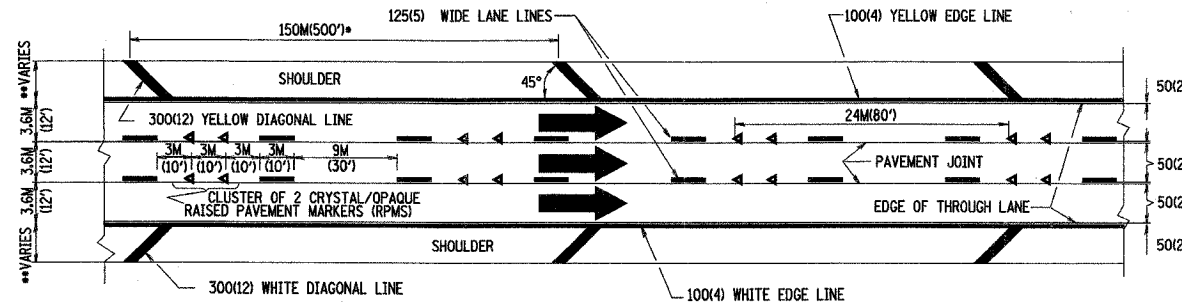

NOTES:

1. THERMO PLASTIC PAVEMENT MARKING LINE SHALL BE USED FOR THE EDGE LINES, GORE LINES, AND DIAGONAL LINES ON BITUMINOUS PAVEMENT ONLY.
2. PREFORMED PLASTIC OR POLYUREA PAVEMENT MARKING LINE SHALL BE USED FOR ALL LANE LINES

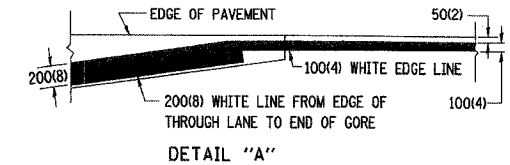

TYPICAL EDGE LINES & LANE LINES

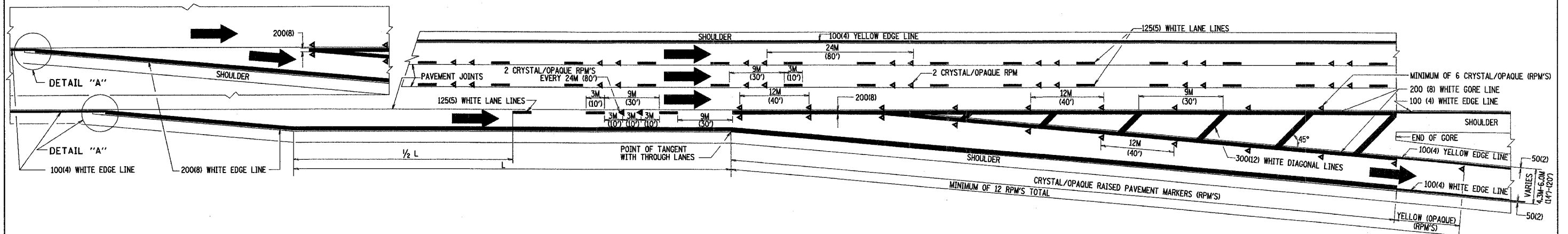

TYPICAL EXIT RAMP PAVEMENT MARKINGS

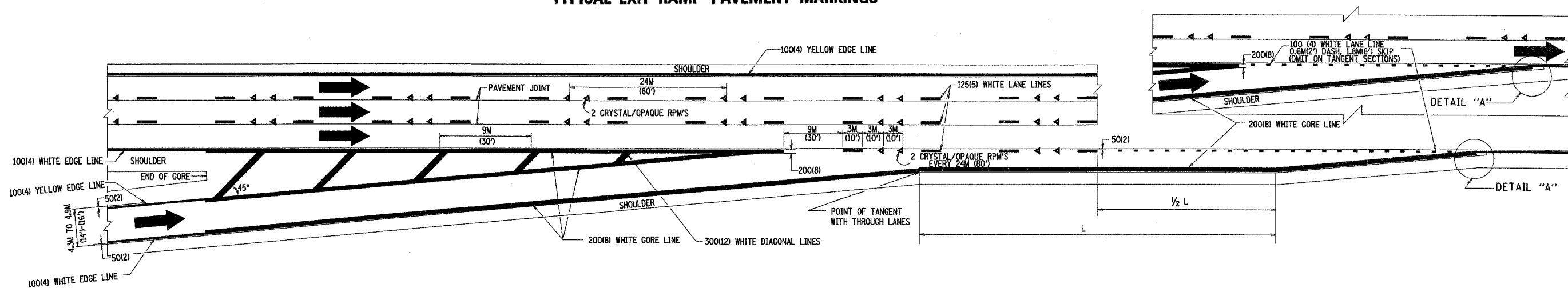

TYPICAL ENTRANCE RAMP PAVEMENT MARKINGS

REVISIONS	
NAME	DATE
DWS	1/90
DWS	5/91
AH	3/96
DWS	7/96
JAF	2/06

ILLINOIS DEPARTMENT OF TRANSPORTATION

MULTI-LANE FREEWAY PAVEMENT MARKING DETAILS

SCALE: NONE
DATE: 3/1/2006

DRAWN BY C.A.D.D.
CHECKED BY

TC12 SHEET 1 OF 2
REVISION DATE: 02/28/06

F.A. RTE.	SECTION	COUNTY	TOTAL SHEETS	SHEET NO.
55			227	135
STA.		TO STA.		
FED. ROAD DIST. NO.	ILLINOIS	FED. AID PROJECT		

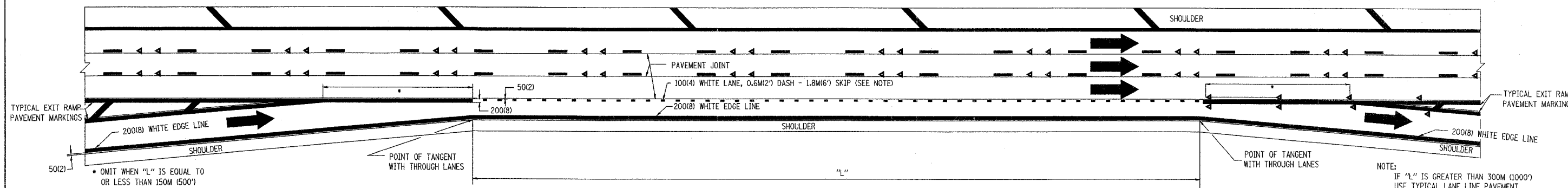

TYPICAL ENTRANCE/EXIT RAMP COMBINATION PAVEMENT MARKINGS

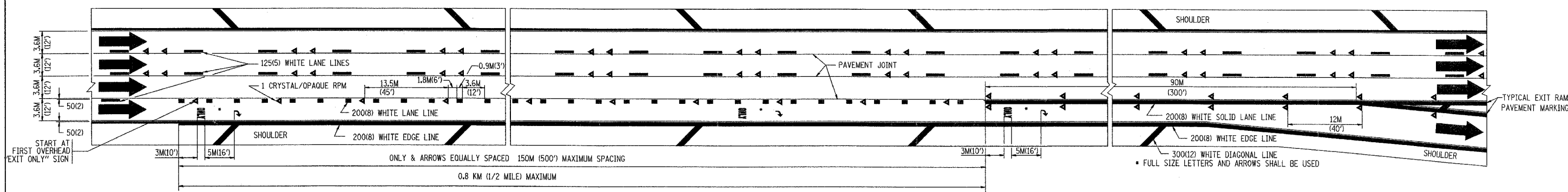

TYPICAL EXIT ONLY LANE PAVEMENT MARKINGS

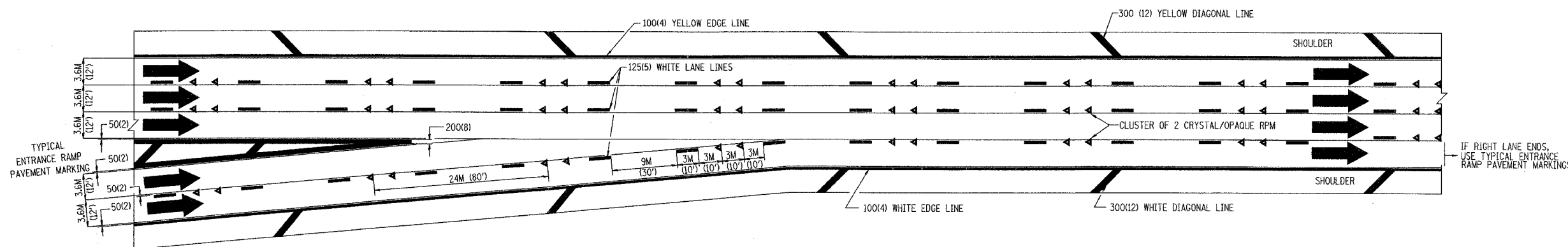

TYPICAL TWO LANE ENTRANCE RAMP PAVEMENT MARKINGS

REVISIONS	
NAME	DATE
DWS	1/90
DWS	5/91

ILLINOIS DEPARTMENT OF TRANSPORTATION

**MULTI-LANE FREEWAY
PAVEMENT MARKING
DETAILS**

SCALE: NONE
DATE: 3/1/2006

DRAWN BY C.A.D.D.

CHECKED BY

TC12 SHEET 2 OF 2

REVISION DATE: 02/28/06

PLOT DATE = 3/1/2006
FILE NAME = K:\Users\cadd\1\02.dgn
PLOT SCALE = 3/8" = 1'-0"
USER NAME = cadd

F.A.I. RTE.	SECTION	COUNTY	TOTAL SHEETS	SHEET NO.
55	99 (1&2) WRS-1	WILL	227	136
STA.		TO STA.		
FED. ROAD DIST. NO.		ILLINOIS FED. AID PROJECT		
LAND-01 OF 2				

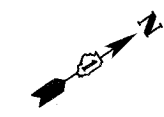

LEGEND

	SEEDLINGS TYPE 1		PR SHADE TREE
	SEEDLINGS TYPE 2		EX SHADE TREE
	SEEDING CLASS 2		PR EVERGREEN TREE
	SEEDING CLASS 2A		EX EVERGREEN TREE
	SEEDING CLASS 3		TREE TRUNK PROTECTION
	SEEDING CLASS 4		MOWSTAKE W/SIGN
	SEEDING CLASS 4 & 5 COMBINED		MOWLINE
	SEEDING CLASS 5		CONTOUR MOUNDING LINE
	SEEDING CLASS 7		SHRUBS
	PERENNIAL PLANTS		
	SODDING		

NOTE:
SEE ROADWAY PLANS FOR EXISTING
TREE REMOVAL

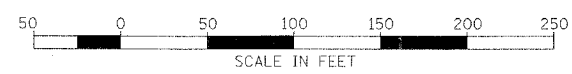
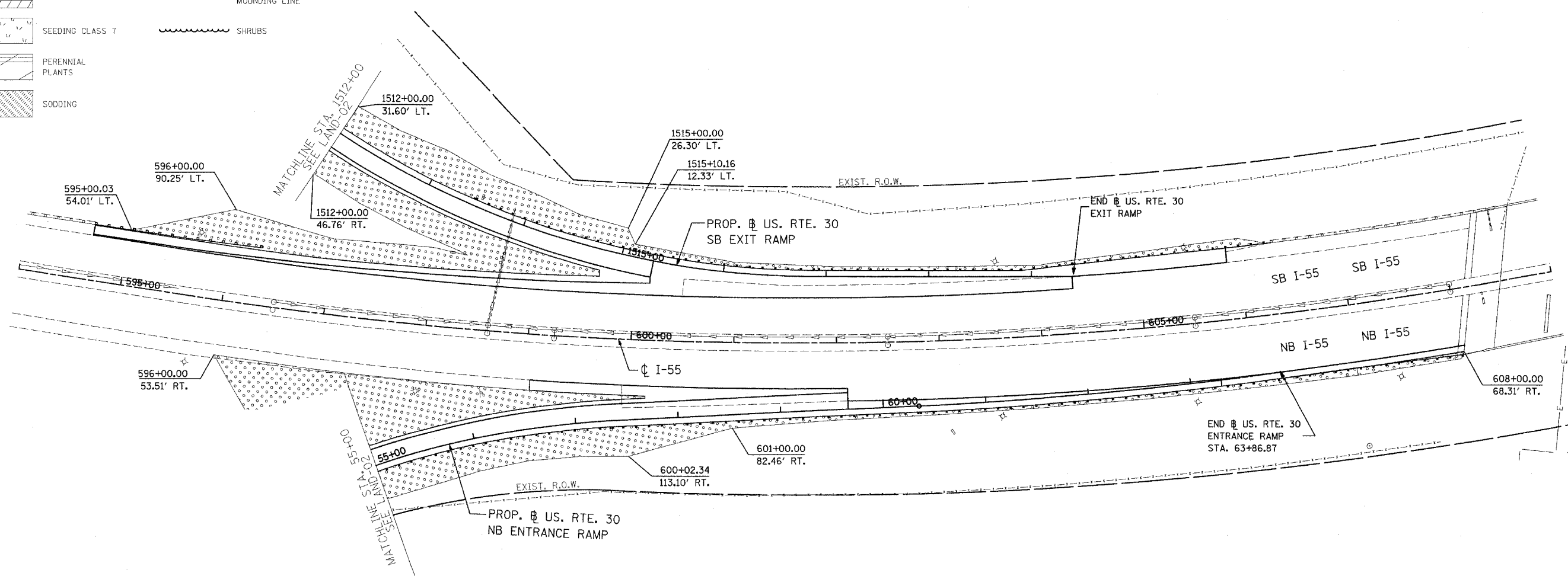

REVISIONS	
NAME	DATE

ILLINOIS DEPARTMENT OF TRANSPORTATION
FAI ROUTE 55
US 30 (PLAINFIELD ROAD) TO 143RD STREET

LANDSCAPING PLANS

SCALE: 1" = 50'
DATE: 02-23-07

DRAWN BY SJV
CHECKED BY DYS

FINAL

F.A.I. RTE.	SECTION	COUNTY	TOTAL SHEETS	SHEET NO.
55	99 (1&2) WRS-1	WILL	227	137
STA.		TO STA.		
FED. ROAD DIST. NO.		ILLINOIS FED. AID PROJECT		
LAND-02 OF 2				

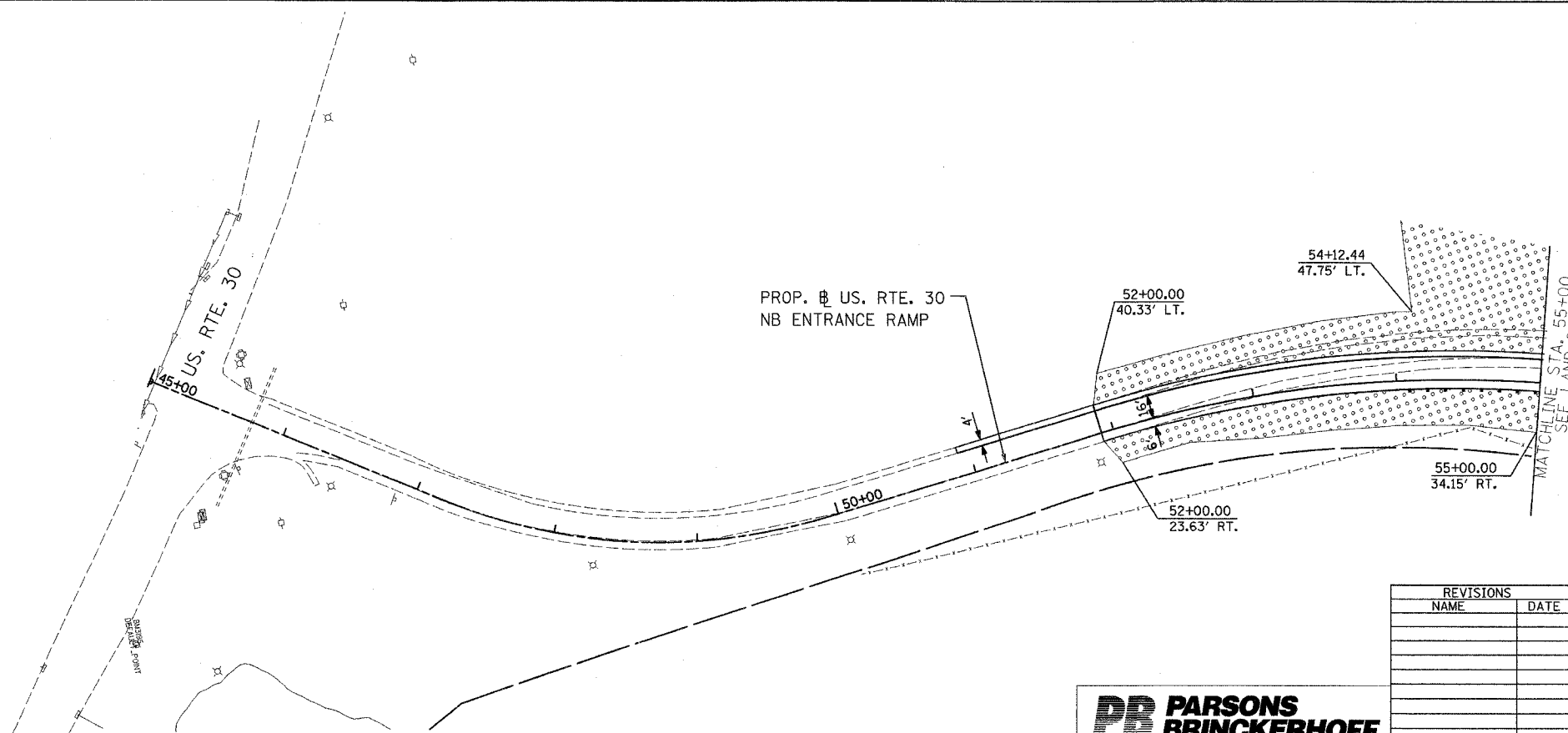
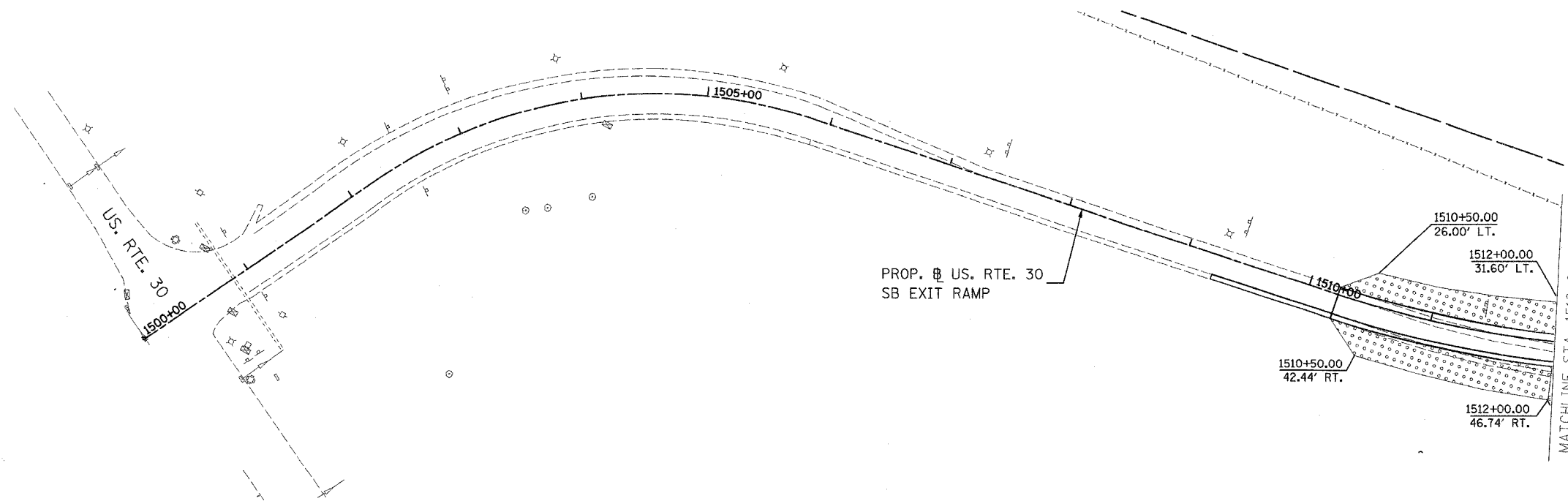

REVISIONS	
NAME	DATE

ILLINOIS DEPARTMENT OF TRANSPORTATION
 FAI ROUTE 55
 US 30 (PLAINFIELD ROAD) TO 143RD STREET

LANDSCAPING
 PLANS

SCALE: 1" = 50'
 DATE: 02-23-07

DRAWN BY: SJV
 CHECKED BY: DVS



FINAL

F.A.I. RTE.	SECTION	COUNTY	TOTAL SHEETS	SHEET NO.
55	99 (I&2) WRS-1	WILL	227	139
STA. 592+00		TO STA. 608+00		
FED. ROAD DIST. NO.1	ILLINOIS FED. AID PROJECT			
L-2 OF 7				

LEGEND

- EXISTING LIGHTING UNIT TO BE REMOVED AND REINSTALLED
- EXISTING LIGHTING UNIT
- EXISTING DUCT
- SIGN STRUCTURE

CIRCUIT DESIGNATION SCHEME

- M CD 1
- POLE NO. ON GIVEN CKT (S)
- CIRCUIT OR CIRCUITS
- LIGHTING CONTROLLER DESIGNATION

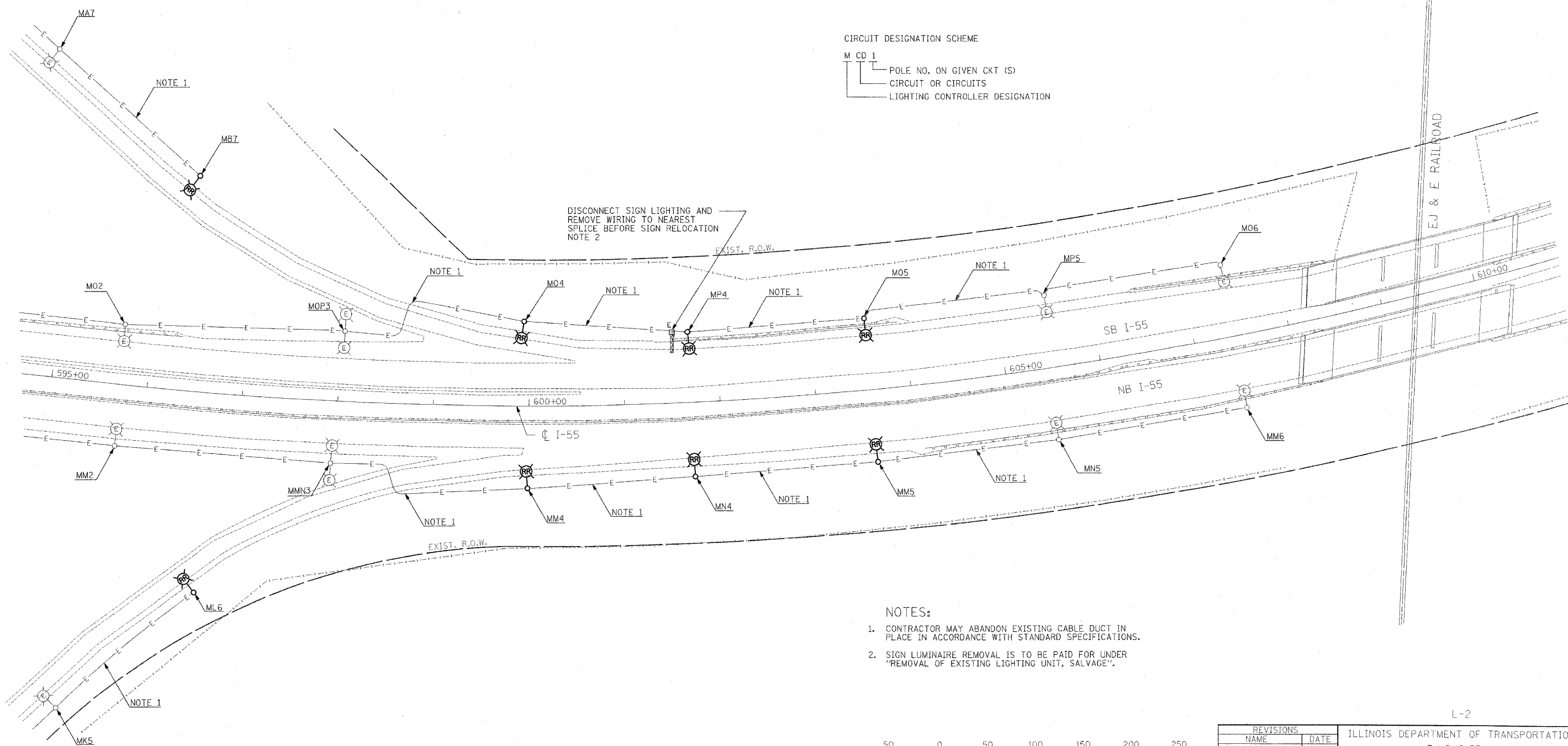
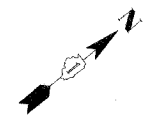

DISCONNECT SIGN LIGHTING AND REMOVE WIRING TO NEAREST SPLICE BEFORE SIGN RELOCATION
NOTE 2

NOTES:

1. CONTRACTOR MAY ABANDON EXISTING CABLE DUCT IN PLACE IN ACCORDANCE WITH STANDARD SPECIFICATIONS.
2. SIGN LUMINAIRE REMOVAL IS TO BE PAID FOR UNDER "REMOVAL OF EXISTING LIGHTING UNIT, SALVAGE".

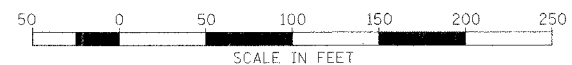

REVISIONS	
NAME	DATE

ILLINOIS DEPARTMENT OF TRANSPORTATION
F.A.I. I-55
US RTE. 30 TO 143rd STREET
EXISTING LIGHTING PLAN

SCALE: 1" = 50'
DATE: 02-23-07

DRAWN BY: VG
CHECKED BY: PV

SINGH 300 W. ADAMS ST. CHICAGO, IL 60606
SINGH & ASSOCIATES, INC. TEL: (312) 629-0240 FAX: (312) 629-8448
CONSULTING ENGINEERS

PB PARSONS BRINCKERHOFF

F.A.I. RTE.	SECTION	COUNTY	TOTAL SHEETS	SHEET NO.
55	99 (1&2) WRS-1	WILL	227	140
STA. 592+00		TO STA. 608+00		
FED. ROAD DIST. NO. 1		ILLINOIS FED. AID PROJECT		
L-3 OF 7				

LEGEND

- EXISTING LIGHTING UNIT RELOCATED TO NEW FOUNDATION, 47.5' MOUNTING HEIGHT ALUMINUM POLE, 15' MAST ARM AND 400W HPS LUMINAIRE WITH NEW TRANSFORMER BASE
- EXISTING LIGHTING UNIT
- GROUND ROD
- UNIT DUCT, WITH 3-1/4" NO.4 AND 1/4" NO.6 GROUND (EPR-TYPE RHW), 1 1/4" DIA., POLYETHYLENE-UNLESS OTHERWISE NOTED
- EXISTING DUCT
- GALVANIZED STEEL CONDUIT, DIAMETER AS INDICATED ON THE PLAN, PUSHED (P) OR IN TRENCH (T)
- SIGN STRUCTURE
- CIRCUIT DESIGNATION SCHEME
- M CD 1
- POLE NO ON GIVEN CKT (S)
- CIRCUIT OR CIRCUITS
- LIGHTING CONTROLLER DESIGNATION

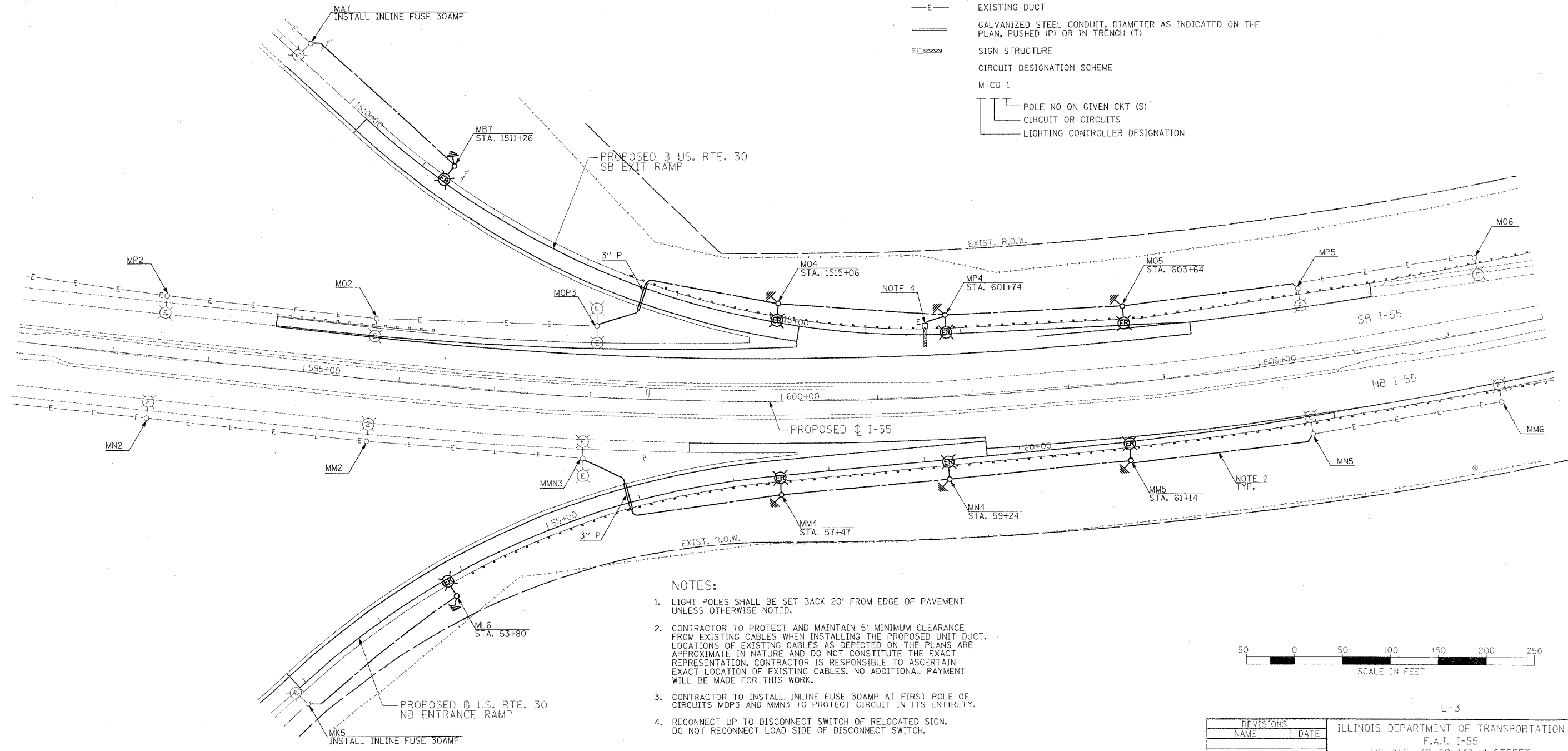
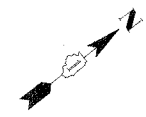

NOTES:

1. LIGHT POLES SHALL BE SET BACK 20' FROM EDGE OF PAVEMENT UNLESS OTHERWISE NOTED.
2. CONTRACTOR TO PROTECT AND MAINTAIN 5' MINIMUM CLEARANCE FROM EXISTING CABLES WHEN INSTALLING THE PROPOSED UNIT DUCT. LOCATIONS OF EXISTING CABLES AS DEPICTED ON THE PLANS ARE APPROXIMATE IN NATURE AND DO NOT CONSTITUTE THE EXACT REPRESENTATION. CONTRACTOR IS RESPONSIBLE TO ASCERTAIN EXACT LOCATION OF EXISTING CABLES. NO ADDITIONAL PAYMENT WILL BE MADE FOR THIS WORK.
3. CONTRACTOR TO INSTALL INLINE FUSE 30AMP AT FIRST POLE OF CIRCUITS MOP3 AND MM3 TO PROTECT CIRCUIT IN ITS ENTIRETY.
4. RECONNECT UP TO DISCONNECT SWITCH OF RELOCATED SIGN. DO NOT RECONNECT LOAD SIDE OF DISCONNECT SWITCH.

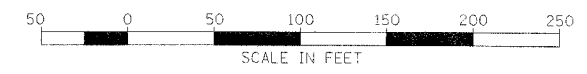

L-3

REVISIONS	
NAME	DATE

ILLINOIS DEPARTMENT OF TRANSPORTATION
 F.A.I. I-55
 US RTE. 30 TO 143rd STREET
 PROPOSED LIGHTING PLAN

SCALE: 1" = 50'
 DATE: 02-23-07

DRAWN BY: VG
 CHECKED BY: PV

SINGH & ASSOCIATES, INC.
 300 N. ADAMS ST.
 CHICAGO, IL 60654
 TEL: (312) 629-0240
 FAX: (312) 629-8446

PB PARSONS BRINCKERHOFF

FINAL

F.A.I. RTE.	SECTION	COUNTY	TOTAL SHEETS	SHEET NO.
55	99 (I&2) WPS-1	WILL	227	141
STA.	TO STA.			
FED. ROAD DIST. NO. 1	ILLINOIS	FED. AID PROJECT		
L-4 OF 7				

LOAD TABLE LIGHTING CONTROLLER "M"					
CIRCUIT	RED PHASE		CIRCUIT	BLACK PHASE	
	AMPS	WATTS		AMPS	WATTS
A	15.4	3,696	B	15.4	3,696
C	15.4	3,696	D	15.4	3,696
E	15.4	3,696	F	15.4	3,696
G	21.0	5,040	H	21.0	5,040
I	19.1	4,591	J	19.5	4,671
K	17.6	4,224	L	17.6	4,224
M	13.2	3,168	N	11.0	2,640
O	14.4	3,456	P	12.2	2,928
TOTAL	133.5	31,567	TOTAL	127.5	30,591

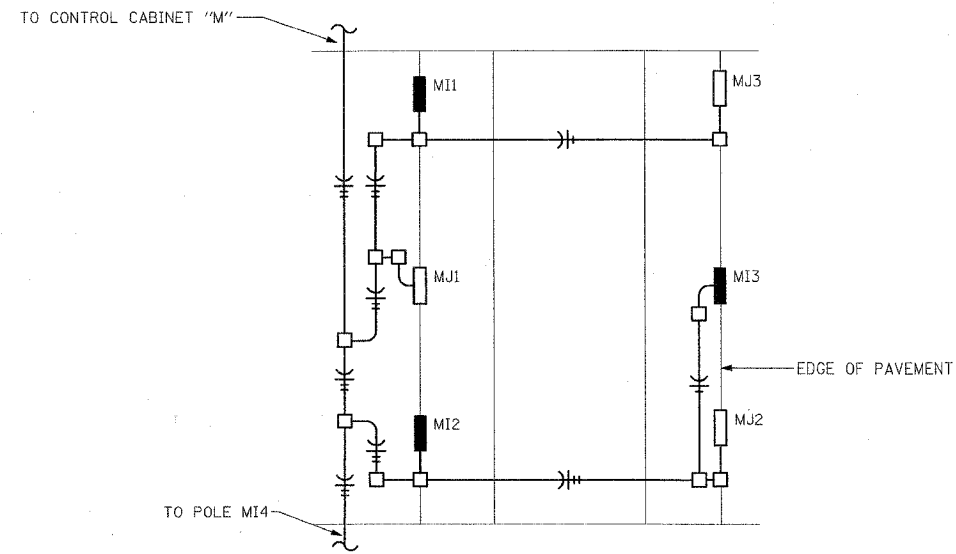

ENLARGED SECTION - UNDERPASS LIGHTING

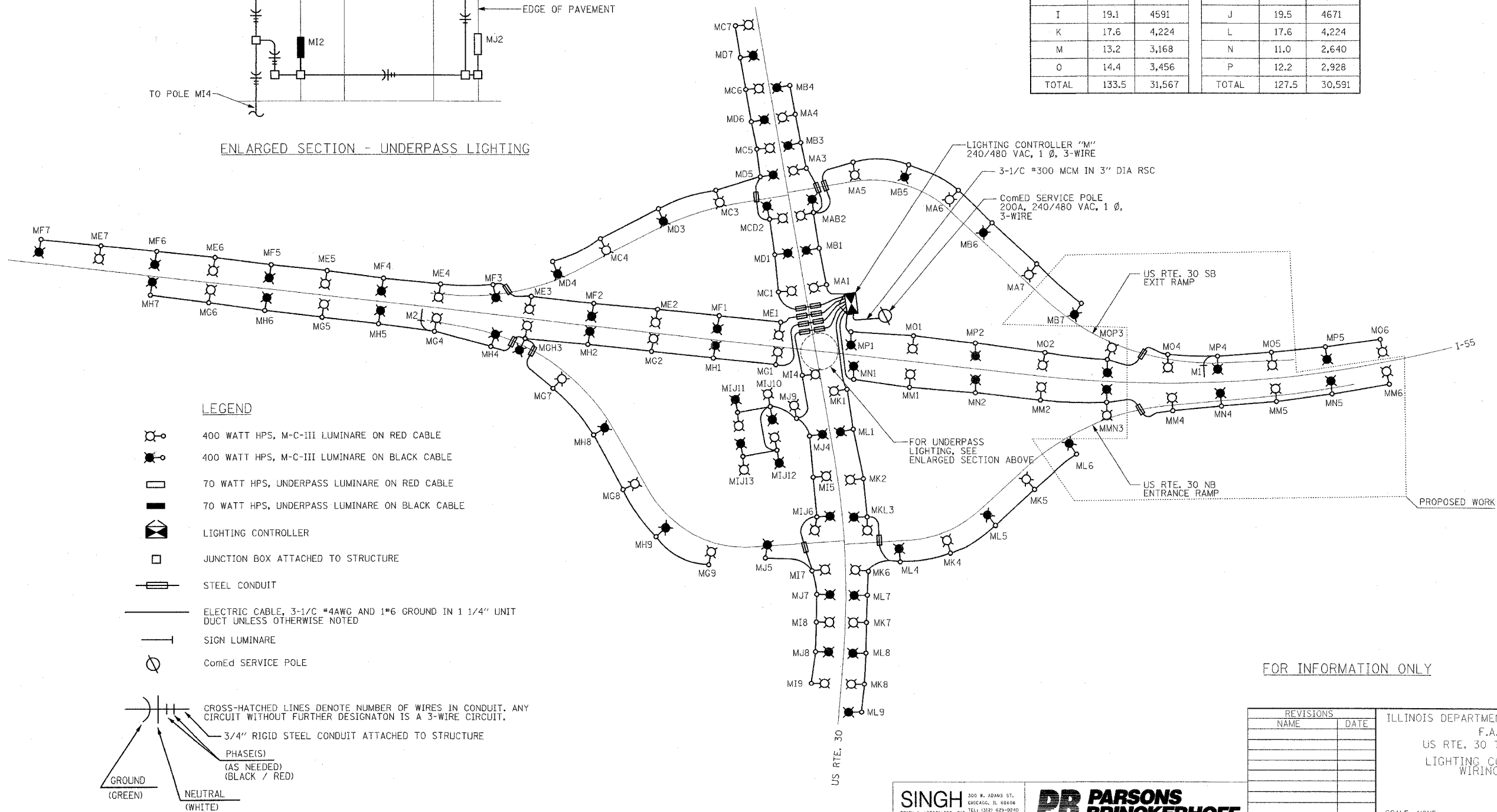

LEGEND

- 400 WATT HPS, M-C-III LUMINARE ON RED CABLE
- 400 WATT HPS, M-C-III LUMINARE ON BLACK CABLE
- 70 WATT HPS, UNDERPASS LUMINARE ON RED CABLE
- 70 WATT HPS, UNDERPASS LUMINARE ON BLACK CABLE
- LIGHTING CONTROLLER
- JUNCTION BOX ATTACHED TO STRUCTURE
- STEEL CONDUIT
-
- SIGN LUMINARE
- ComEd SERVICE POLE
-
-
-
-
-

FOR INFORMATION ONLY

L-4

REVISIONS	
NAME	DATE

ILLINOIS DEPARTMENT OF TRANSPORTATION
F.A.I. I-55
US RTE. 30 TO 143rd STREET
LIGHTING CONTROLLER "M"
WIRING DIAGRAM

SCALE: NONE
DATE: 02-23-07

DRAWN BY: VG
CHECKED BY: PV

SINGH
300 W. ADAMS ST.
CHICAGO, IL 60609
TEL: (312) 629-0240
FAX: (312) 629-8449
CONSULTING ENGINEERS

**PB PARSONS
BRINCKERHOFF**

FINAL

CONTRACT NO.		TOTAL SHEETS		SHEET NO.	
F.A. RTE.	SECTION	COUNTY	WILL	227	142
STA.		TO STA.			
FED. ROAD DIST. NO. 1		ILLINOIS		FED. AID PROJECT	

LIGHT POLE FOUNDATION DEPTH TABLE
12.192M (40 FT.) TO 14.478M (47.5 FT.) MOUNTING HEIGHT

SOIL CONDITIONS	DESIGN DEPTH "D" OF FOUNDATION	
	SINGLE ARM POLE	TWIN ARM POLE
SOFT CLAY Qu = 0.375 TON/SO. FT.	3.96M (13'-0")	4.67M (15'-0")
MEDIUM CLAY Qu = 0.75 TON/SO. FT.	2.09M (9'-6")	3.23M (10'-9")
STIFF CLAY Qu = 1.50 TON/SO. FT.	2.13M (7'-0")	2.44M (8'-0")
LOOSE SAND β = 34°	2.74M (9'-0")	3.05M (10'-0")
MEDIUM SAND β = 37.5°	2.52M (8'-3")	2.74M (9'-0")
DENSE SAND β = 40°	2.36M (7'-9")	2.74M (9'-0")

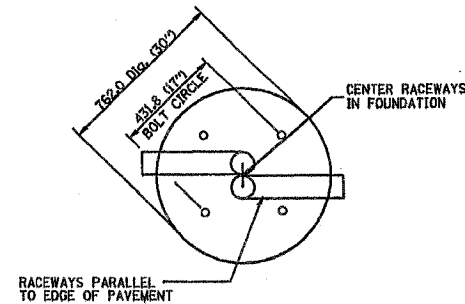
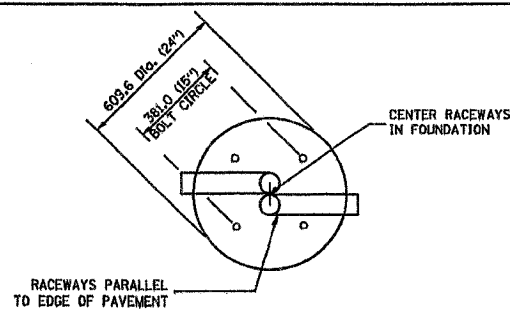

TOP VIEW

TOP VIEW

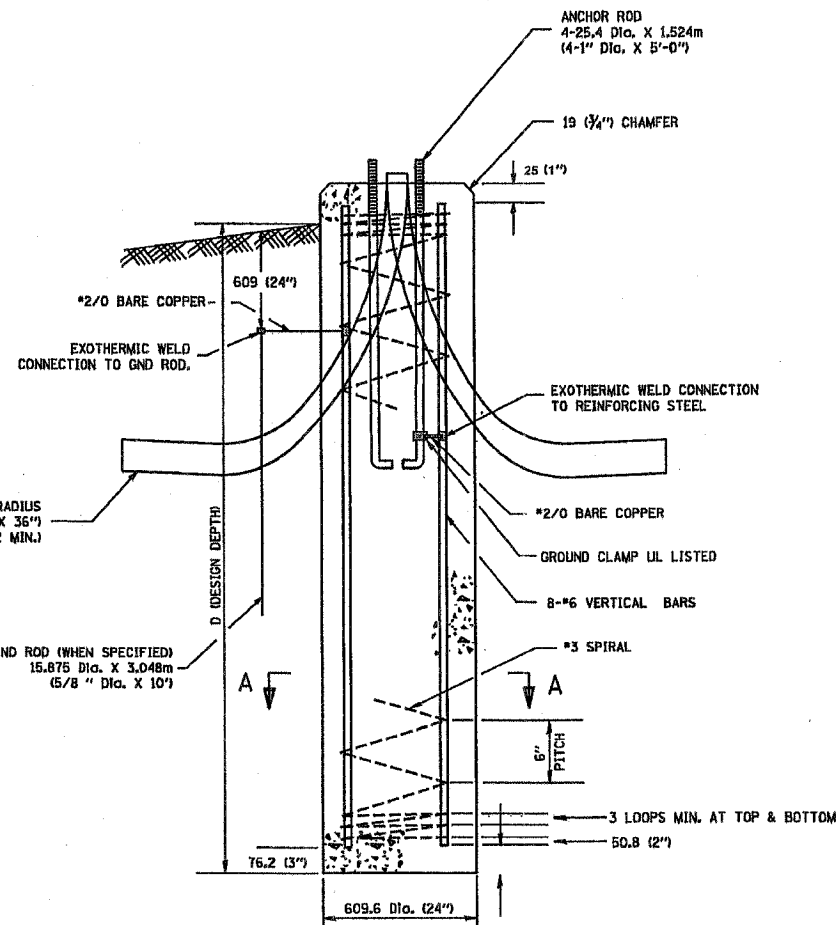

FOUNDATION DETAIL

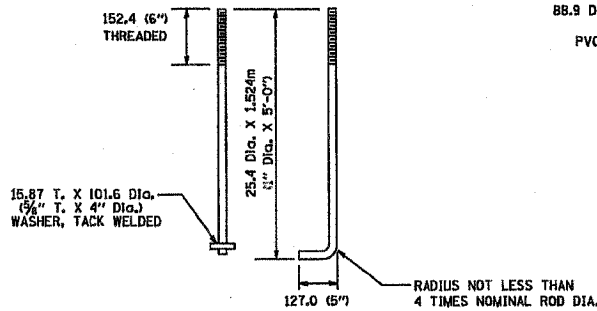

ANCHOR ROD DETAIL

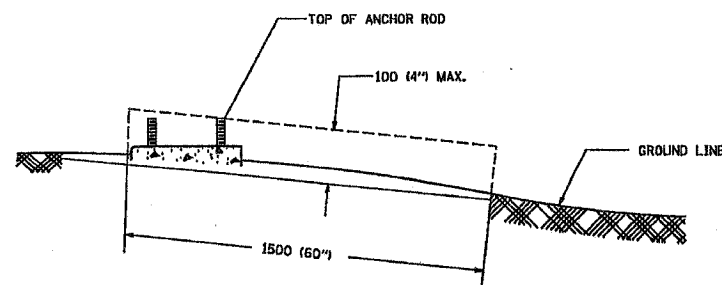

FOUNDATION EXTENSION DETAIL

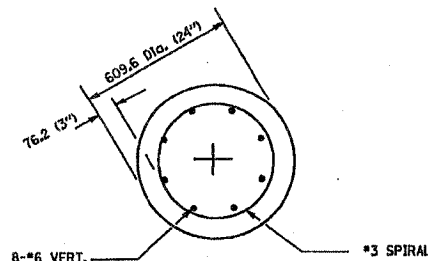

SECTION A-A

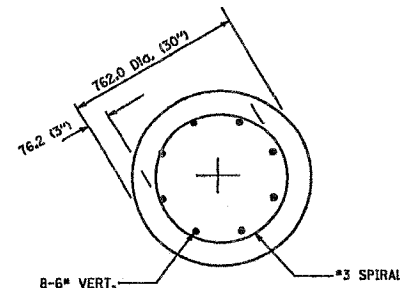

SECTION A-A

NOTES

- ALL DIMENSIONS ARE IN MILLIMETERS (INCHES) UNLESS OTHERWISE SHOWN.
- THE ANCHOR RODS AND RACEWAYS SHALL BE PROPERLY SECURED IN PLACE BEFORE THE CONCRETE IS PLACED.
- THE FOUNDATION SHALL NOT PROTRUDE MORE THAN 100MM (4 IN.) ABOVE THE FINISHED GRADE WITHIN A 1.5M (60 IN.) CHORD ACROSS THE FOUNDATION, WITH ANCHOR RODS INCLUDED, IN ACCORDANCE WITH AASHTO GUIDELINES. IF THE FOUNDATION HEIGHT, INCLUDING ANCHOR RODS, EXTENDS BEYOND THESE SPECIFIED LIMITS, THE FOUNDATION SHALL BE REPLACED AT THE CONTRACTOR'S EXPENSE. SEE FOUNDATION EXTENSION DETAIL.
- THE HOLE FOR THE FOUNDATION SHALL BE MADE BY DRILLING WITH AN AUGER, OF THE SAME DIAMETER AS THE FOUNDATION. IF SOIL CONDITIONS REQUIRE THE USE OF A LINER TO FORM THE HOLE, THE LINER SHALL BE WITHDRAWN AS THE CONCRETE IS DEPOSITED.
- THE TOP OF THE FOUNDATION SHALL BE CONSTRUCTED LEVEL. A LINER OR FORM SHALL BE USED TO PRODUCE A UNIFORM SMOOTH SIDE TO THE TOP OF THE FOUNDATION. FOUNDATION TOP SHALL BE CHAMFERED 20MM (3/4-IN.).
- THE CONCRETE SHALL BE CLASS SI. CONCRETE SHALL CURE ACCORDING TO ARTICLE 1020.13 BEFORE LIGHT POLES ARE INSTALLED.
- THE ANCHOR ROD SHALL BE A HOOK ROD TYPE. COLD BENDING OF THE ANCHOR ROD WILL NOT BE ALLOWED. THE RADIUS OF THE HOOK BEND SHALL NOT BE LESS THAN 4 TIMES THE NOMINAL DIAMETER OF THE ANCHOR ROD. A TACK WELDED ANCHOR ROD MAY BE SUBSTITUTED WITH THE APPROVAL OF THE ENGINEER.
- THE ANCHOR RODS SHALL BE ACCORDING TO ASTM F1554 GRADE 725 (GRADE 105). NUTS SHALL BE HEXAGON NUTS ACCORDING TO ASTM A 194 2H OR ASTM A 563 DH, AND WASHERS SHALL BE ACCORDING TO ASTM F 436.
- ANCHOR RODS, NUTS AND WASHERS SHALL BE COMPLETELY GALVANIZED BY EITHER THE HOT-DIPPED PROCESS CONFORMING WITH AASHTO M 232, THE MECHANICAL PLATING METHOD CONFORMING TO AASHTO M 298, CLASS 50 WITH A MAXIMUM COATING THICKNESS OF 150 UM(6 MILS) OR THE ELECTROLYTIC PROCESS ACCORDING TO ASTM F 1136.
- THE ANCHOR RODS SHALL BE THREADED A MINIMUM OF 150 MM (6 INCHES) WITH A MINIMUM OF 75 MM (3 INCHES) OF THREADED ANCHOR ROD EMBEDDED IN THE FOUNDATION.
- ANCHOR RODS SHALL PROJECT 69.9MM (2 3/4") ABOVE THE TOP OF THE FOUNDATION. IF BREAKAWAY COUPLINGS ARE SPECIFIED, THE CONTRACTOR SHALL CAREFULLY COORDINATE THE ANCHOR ROD PROJECTION WITH THE INSTALLATION REQUIREMENTS OF THE BREAKAWAY COUPLINGS.
- THE CONTRACTOR SHALL USE A #3 SPIRAL AT 152.4MM (6") PITCH OR MAY SUBSTITUTE #3 TIES AT 304.8MM (12") O.C. WITH THE APPROVAL OF THE ENGINEER.
- THE CABLE TRENCHES AND FOUNDATION SHALL BE BACK FILLED AND COMPACTED AS SPECIFIED BEFORE THE LIGHT POLE IS ERECTED.
- THE RACEWAYS SHALL PROJECT 25.4MM (1") ABOVE THE TOP OF THE FOUNDATION.
- BOLT CIRCLE TO MATCH EXISTING POLE BOLT CIRCLE.

PLT DATE = 2/15/2006
FILE NAME = w:\dms\104214.dgn
USER NAME = gpl\gpl001

SINGH 300 W. ADAMS ST.
CHICAGO, IL 60606
TELE (312) 629-0049
FAX (312) 629-0449
CONSULTING ENGINEERS

REVISIONS	
NAME	DATE

L-5 E-301
ILLINOIS DEPARTMENT OF TRANSPORTATION
LIGHT POLE FOUNDATION
12.192M (40') TO 14.478M (47 1/2') M.H.
381 (15") BOLT CIRCLE

SCALE: NONE
DATE: 2/15/2006

DRAWN BY
CHECKED BY
BE301

REVISION DATE: 04/22/02

CONTRACT NO.			
F.A. RTE.	SECTION	COUNTY	TOTAL SHEETS
55	99 (1&2) WRS-1	WILL	227
STA.		TO STA.	
FED. ROAD DIST. NO. 1 ILLINOIS FED. AID PROJECT			

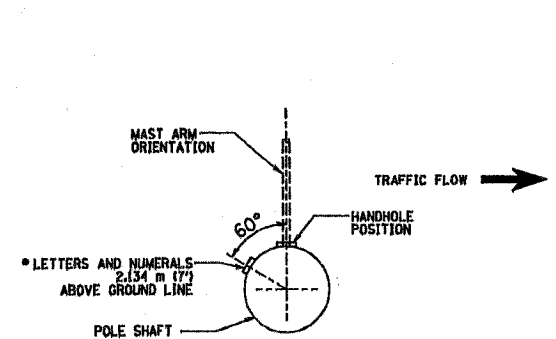

POSITION OF HANDHOLE AND POLE NUMBER FOR SINGLE MAST ARM POLES MOUNTED ON BRIDGE PARAPET OR BARRIER WALL

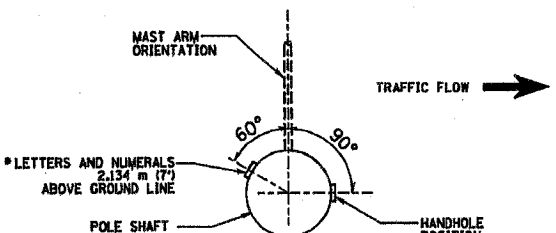

POSITION OF HANDHOLE AND POLE NUMBER FOR SINGLE MAST ARM POLES

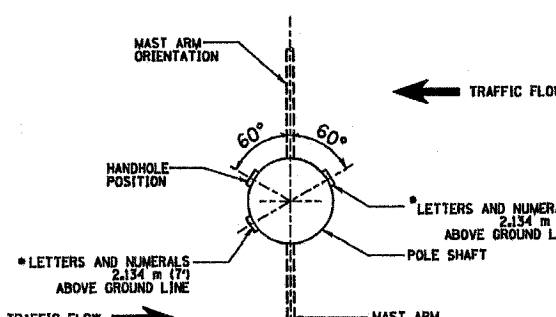

POSITION OF HANDHOLE AND POLE NUMBER FOR TWIN MAST ARM POLES

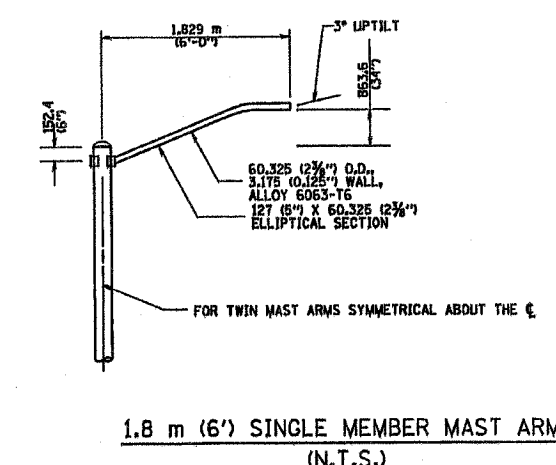
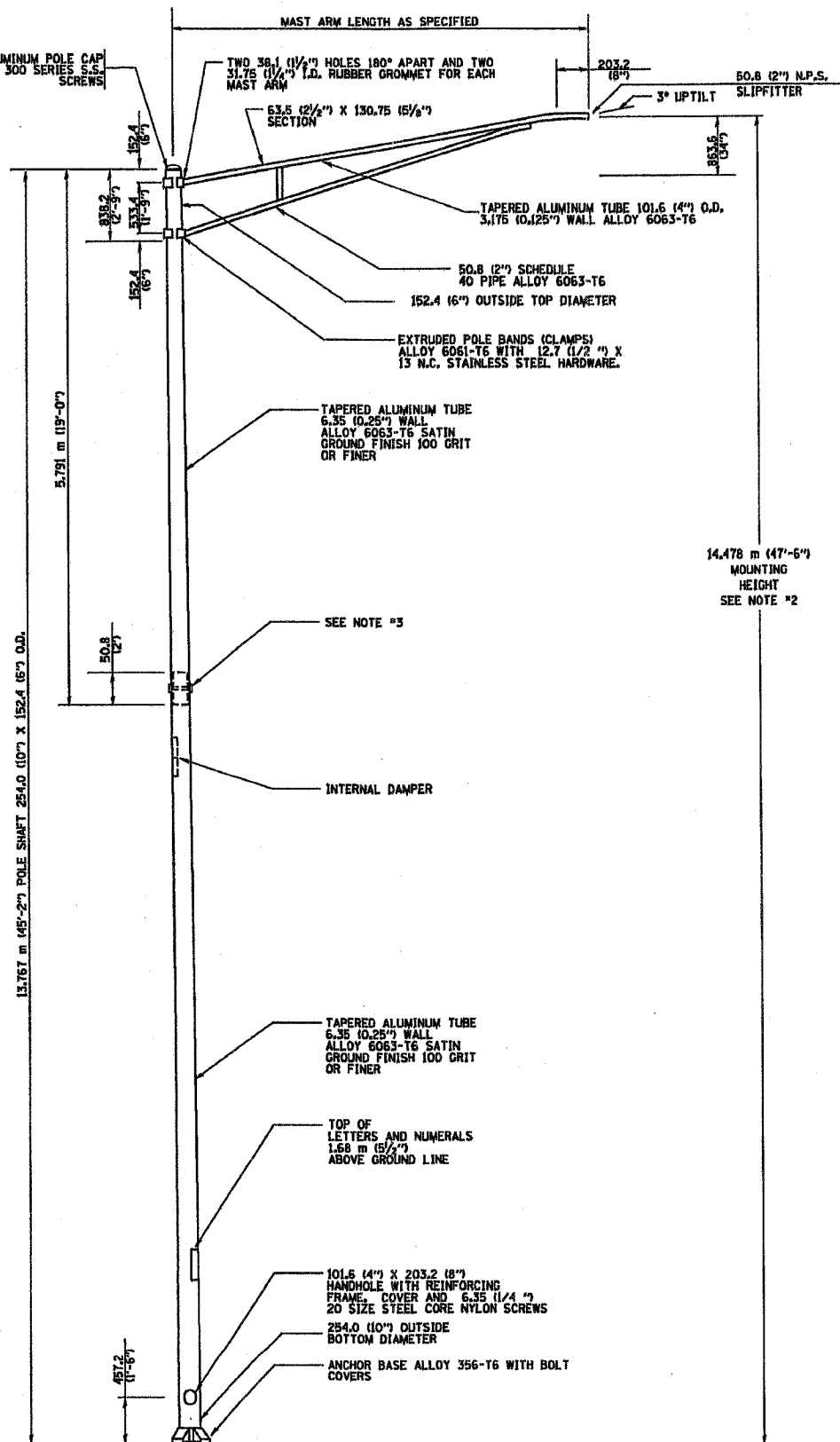

1.8 m (6') SINGLE MEMBER MAST ARM (N.T.S.)

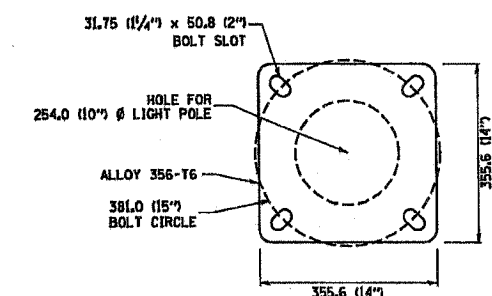

LIGHT POLE BASE PLATE DETAIL
381.0 (15 INCH) BOLT CIRCLE

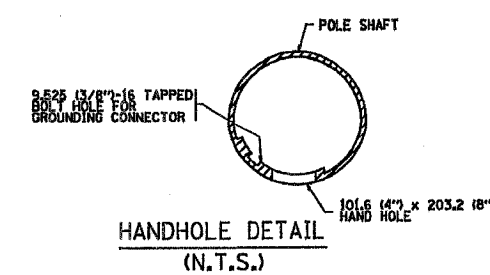

HANDHOLE DETAIL (N.T.S.)

- NOTES:
- ALL DIMENSIONS ARE IN MILLIMETERS (INCHES) UNLESS OTHERWISE SHOWN.
 - MOUNTING HEIGHT IS DEFINED AS THE DISTANCE FROM THE CENTERLINE OF THE TEMON TO THE BOTTOM OF THE ANCHOR BASE.
 - TWO PIECE SHAFT WILL BE MATCHED MARKED AND INTERCHANGEABLE BETWEEN DIFFERENT UNITS. FIELD DRILLING OF THE HOLES WILL NOT BE ALLOWED.
 - THE LIGHT POLE WILL MEET AASHTO DESIGN CRITERIA AS SPECIFIED.
 - THE INSTALLING CONTRACTOR WILL PROVIDE A LISTED GROUNDING CONNECTOR, BURNDY K2C3, T&B SP-4DL OR APPROVED EQUAL.
 - LIGHT POLES WILL NOT BE INSTALLED WITHOUT MAST ARMS AND LUMINAIRES.
 - LIGHT POLES WILL BE SET PLUMB ON THE FOUNDATION WITHOUT THE USE OF LEVELING NUTS, WASHERS OR SHIMS.
 - LIGHTING UNIT IDENTIFICATION NUMBERS SHALL BE INSTALLED BEFORE THE LIGHTING UNIT IS ENERGIZED.

FOR INFORMATION ONLY

REVISIONS	
NAME	DATE
R. TOMSONS	9-6-00
R. TOMSONS	8-12-03

ILLINOIS DEPARTMENT OF TRANSPORTATION
ALUMINUM LIGHT POLE
14.478 m (47'-6")
MOUNTING HEIGHT

SCALE: NONE
DATE: 2/15/2006
DRAWN BY: BE-400
CHECKED BY: BE-400
REVISION DATE: 09/02/03

SINGH
300 W. ADAMS ST.
CHICAGO, IL 60606
TEL: (312) 629-0240
FAX: (312) 629-9449

PLOT DATE: 2/15/2006
FILE NAME: M:\Users\jg\My Documents\Light Pole.dwg
PLOT SCALE: 1/8" = 1'-0"
USER NAME: jg

CONTRACT NO.				
F.A. RYE.	SECTION	COUNTY	TOTAL SHEETS	SHEET NO.
55	99 (I&2) WRS-1	WILL	227	144
STA.		TO STA.		
FED. ROAD DIST. NO. 1		ILLINOIS FED. AID PROJECT		

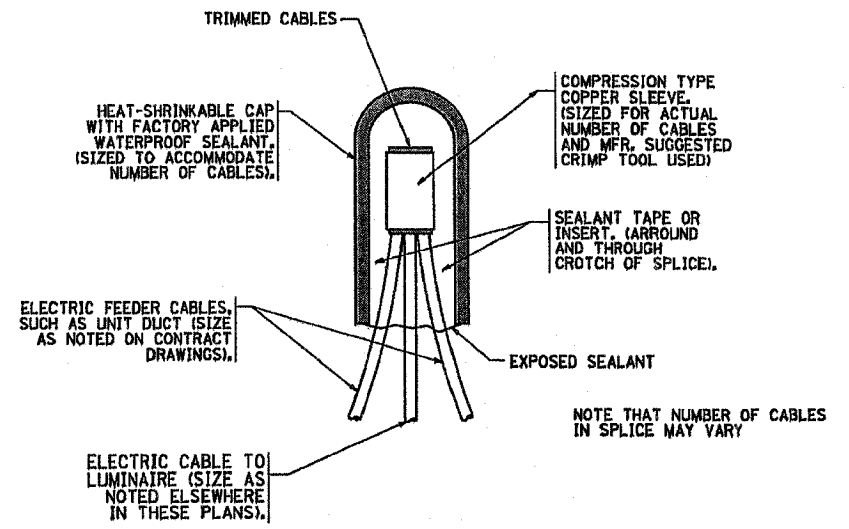

TYPICAL SPLICE DETAIL
N.T.S.

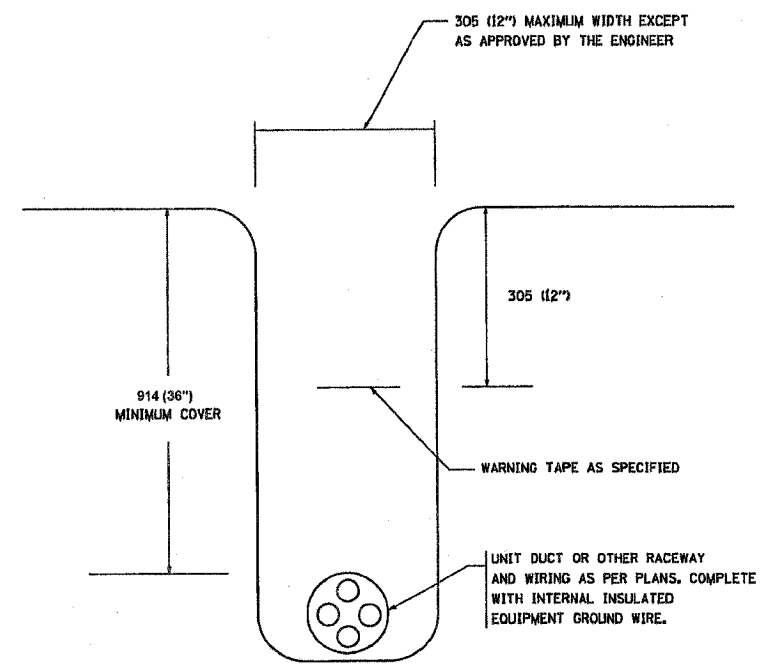

TYPICAL WIRING IN TRENCH DETAIL
N.T.S.

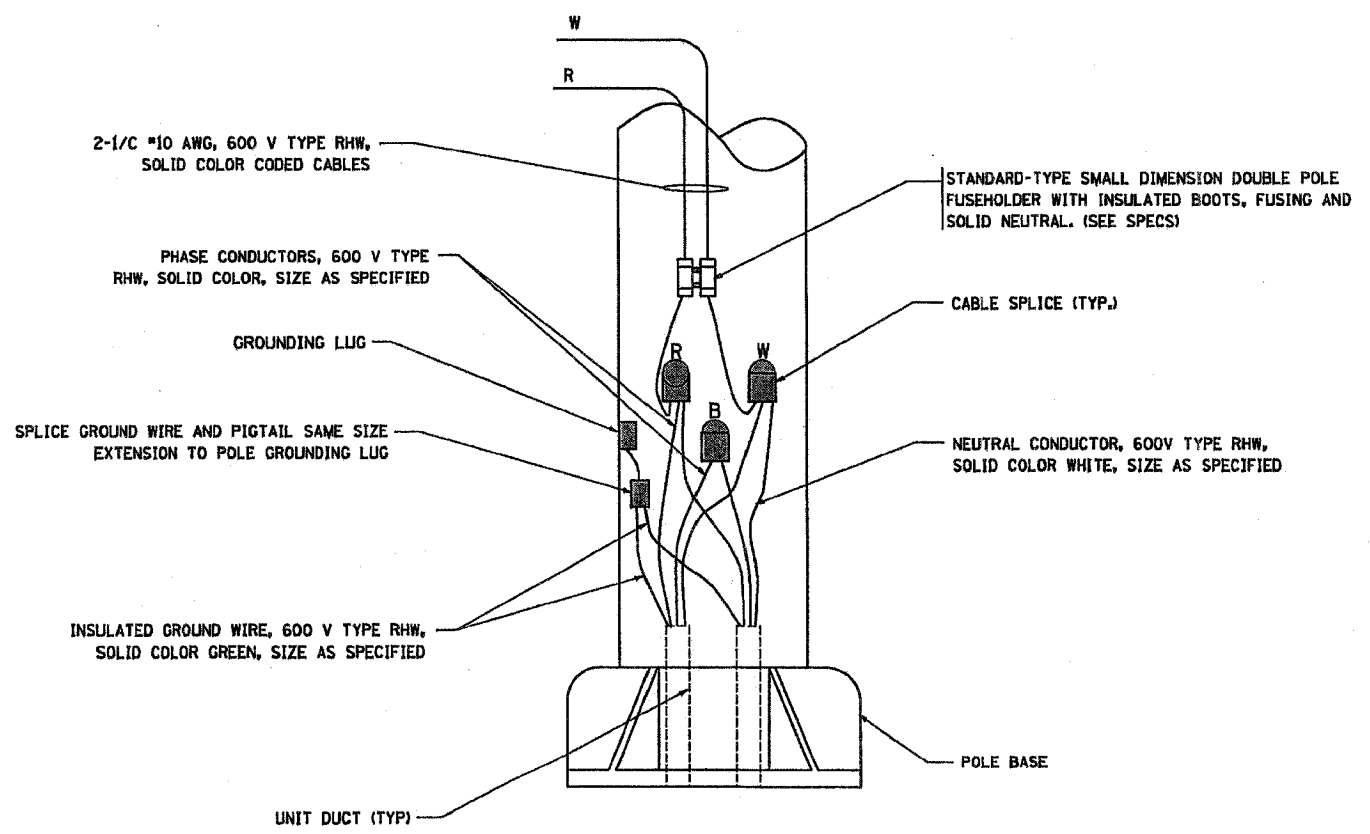

POLE WIRING DETAIL
N.T.S.

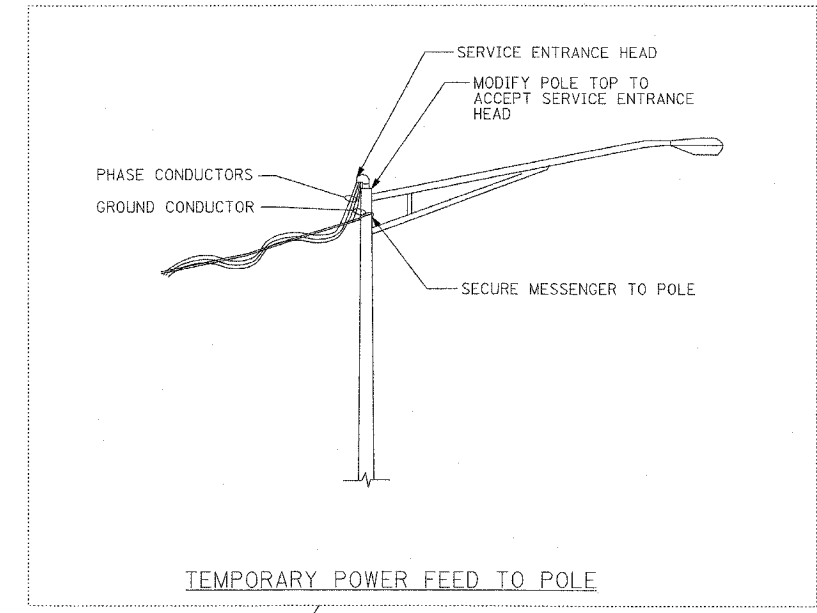

FOR INFORMATION ONLY

L-7

PLOT DATE: 2/15/2006
 FILE NAME: W:\Projects\097620\097620.dwg
 PLOT SCALE: 1/8"=1'-0"
 USER: JAC

SINGH
 SINGH & ASSOCIATES, INC.
 CONSULTING ENGINEERS

300 W. ADAMS ST.
 CHICAGO, IL 60606
 TEL: (312) 629-0240
 FAX: (312) 629-0449

REVISIONS	
NAME	DATE

ILLINOIS DEPARTMENT OF TRANSPORTATION

MISC. ELECTRICAL DETAILS

SCALE: VERT.
 HORIZ.
 DATE: 2/15/2006

DRAWN BY
 CHECKED BY
 BE-702
 REVISION DATE:

STATE OF ILLINOIS
DEPARTMENT OF TRANSPORTATION

ROUTE NO.	SECTION	COUNTY	TOTAL SHEETS	SHEET NO.
FAI 55	**	WILL	227	145
FED. ROAD DIST. NO. 7	ILLINOIS	FED. AID PROJECT		

SHEET NO. 1
5 SHEETS

** SECTION 99 (1&2) WRS-1
CONTRACT NO. 62896

B.M. 3216 -
Square cut near NE corner of middle pier between NB & SB lanes of I-55 under Airport Rd.
(Also Lockport-Plainfield Rd.)
El. 617.57.

Existing Structure -
Structure No. 099-0176 was rehabilitated as Plainfield/Lockport Road Section 99-1HB-2-BR
in 2002. The existing structure is 188'-0" Bk. to Bk. of Abutments and is a four-span structure
consisting of a 32'-0" wide reinforced concrete deck supported on a continuous steel wide flange
beam superstructure. The existing substructure was rehabilitated and incorporated into the 2002
improvements and consists of stub type abutments and concrete piers supported on a pile foundation.

Salvage -
None

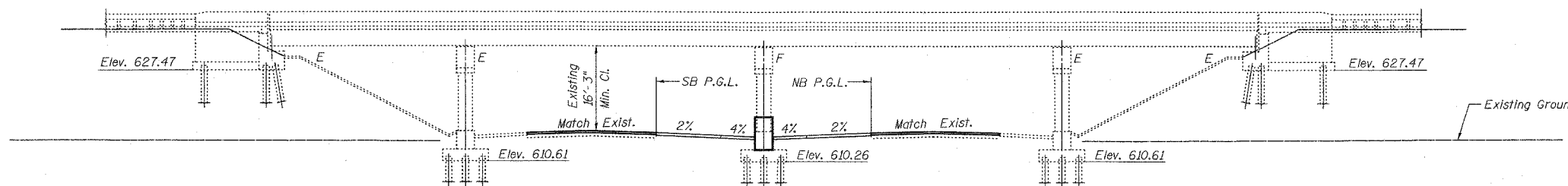

ELEVATION

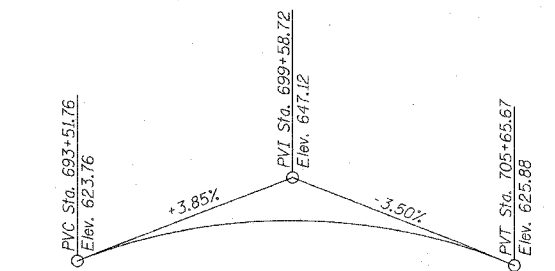

EXISTING PLAINFIELD/LOCKPORT ROAD
PROFILE GRADE

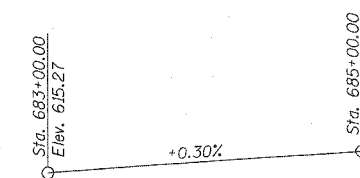

SB I-55 PROFILE GRADE

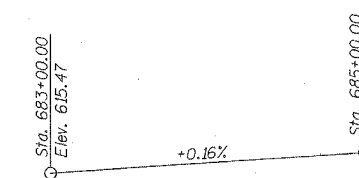

NB I-55 PROFILE GRADE

SCOPE OF WORK

1. Repair substructure defects at Pier 1, Pier 2, & Pier 3 with Structural Repair of Concrete and/or Epoxy Crack Sealing.
2. The Pier 2 Crashwall will be extended to a height equal to 42" from edge of pavement to match the proposed I-55 mainline median barrier configuration.

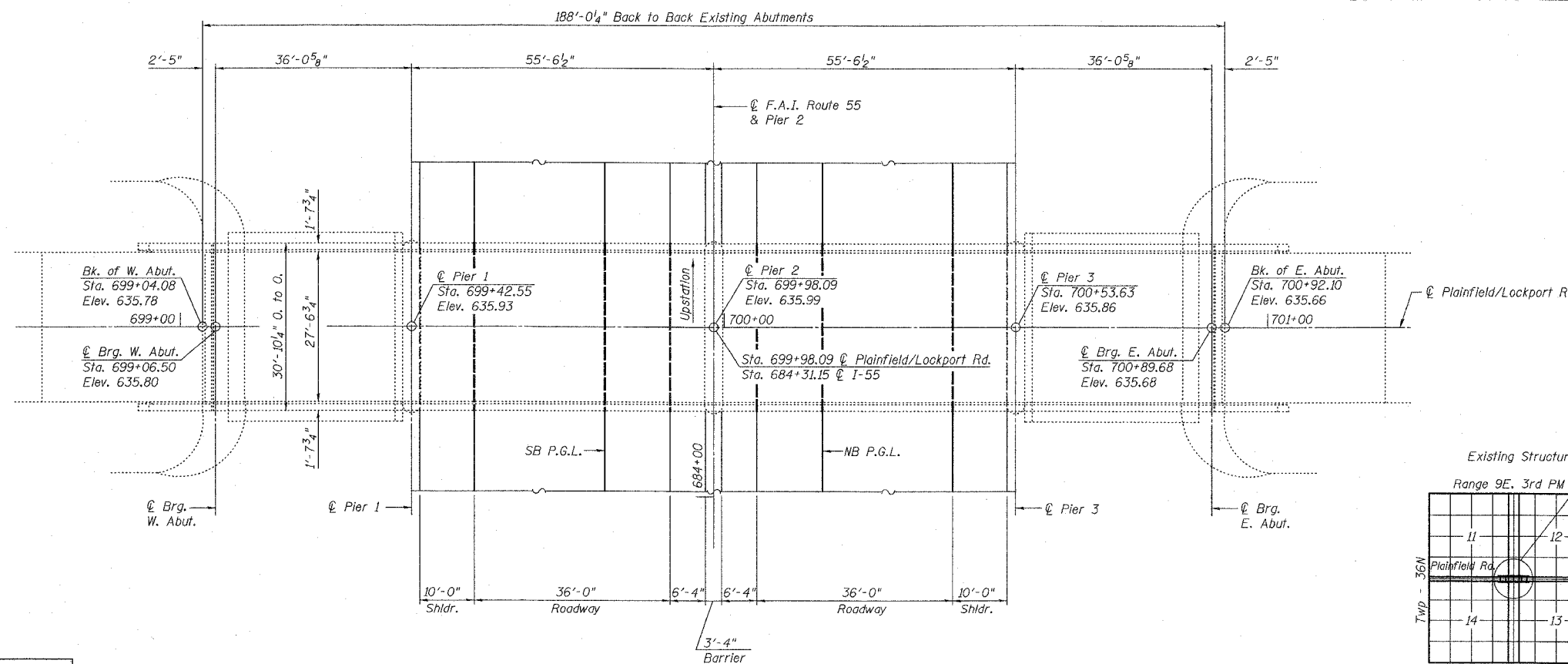

PLAN

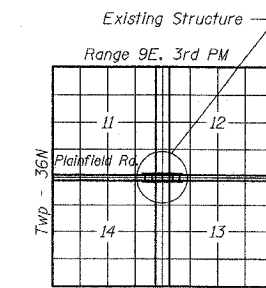

LOCATION SKETCH

DESIGN SPECIFICATIONS

AASHTO 2002

LOADING HS20-44

Allow 50#/Sq. Ft. for future wearing surface.

DESIGN STRESSES

FIELD UNITS

f_c = 3,500 psi
f_y = 60,000 psi (reinforcement)



Signed Jamal Grainawi
Jamal I. Grainawi, S.E., IL Lic. No. 081-005161
Expires 11-30-2008
Date 2/23/2007

GENERAL PLAN AND ELEVATION
PLAINFIELD ROAD OVER I-55
SECTION 99 (1&2) WRS-1
WILL COUNTY
STA. 699+98.09
STRUCTURE NO. 099-0176



DESIGNED	S.CHELBIAN
CHECKED	J.GRAINAWI
DRAWN	D.C.PATEL
CHECKED	J.GRAINAWI

Date: 2/23/2007

STATE OF ILLINOIS
DEPARTMENT OF TRANSPORTATION

ROUTE NO.	SECTION	COUNTY	TOTAL SHEETS	SHEET NO.
FAI 55	**	WILL	227	146
FED. ROAD DIST. NO. 7	SLAB/IS	FED. AID PROJECT		

** SECTION 99 (1&2) WRS-1
CONTRACT NO. 62896

GENERAL NOTES:

1. Plan dimensions and details relative to existing structure have been taken from existing plans and are subject to nominal construction variations. It shall be the Contractor's responsibility to verify such dimensions and details in the field and make necessary approved adjustments prior to construction or ordering of materials. Such variations shall not be cause for additional compensation for a change in the scope of the work; however, the Contractor will be paid for the quantity actually furnished at the unit price for the work.
2. All Construction Joints shall be bonded.

INDEX OF SHEETS

1. Existing General Plan & Elevation
2. General Notes & Bill of Materials
3. Pier 1 Repair Details
4. Pier 2 Repair Details
5. Pier 3 Repair Details

TOTAL BILL OF MATERIAL

ITEM	UNIT	SUPER	SUB	TOTAL
Concrete Removal	Cu. Yd.		0.9	0.9
Concrete Structures	Cu. Yd.		6.6	6.6
* Reinforcement Bars, Epoxy Coated	Pound		340	340
* Structural Repair of Concrete (Depth Equal to or Less Than 5")	Sq. Ft.		235.3	235.3
Epoxy Crack Sealing	Foot		3	3
* Temporary Shoring and Cribbing	L.S.		1	1

* See Special Provisions

2/16/2007 9:52:08 AM G:\18817A\Struct\Cadd\Pre-Final\LOCKPORT\Final Submittal to IDOT\BO_022307\092206-62896-000-00-002.dgn

DESIGNED	S.CHELBIAN
CHECKED	J.GRAINAWI
DRAWN	D.C.PATEL
CHECKED	J.GRAINAWI

Date: 2/23/2007

GENERAL NOTES
& BILL OF MATERIALS
PLAINFIELD ROAD OVER I-55
SECTION 99 (1&2) WRS-1
WILL COUNTY
STA. 699+98.09
STRUCTURE NO. 099-0176



STATE OF ILLINOIS
DEPARTMENT OF TRANSPORTATION

ROUTE NO.	SECTION	COUNTY	TOTAL SHEETS	SHEET NO.
FAI 55	**	WILL	227	147
FED. ROAD DIST. NO. 7	ILLINOIS	FED. AID PROJECT-		

** SECTION 99 (1&2) WRS-1
CONTRACT NO. 62896

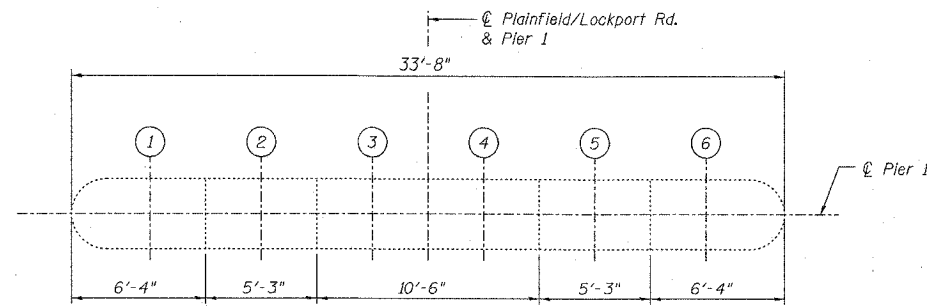
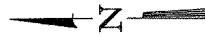

TOP PLAN

BILL OF MATERIAL

Item	Unit	Total
Structural Repair of Concrete (Depth Equal to or Less Than 5")	Sq. Ft.	113.3

LEGEND

Structural Repair of Concrete
(Depth equal to or less than 5")

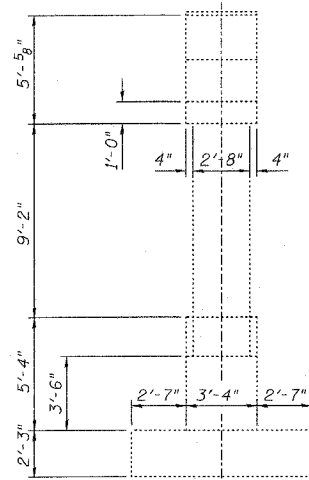

END VIEW
(Looking South)

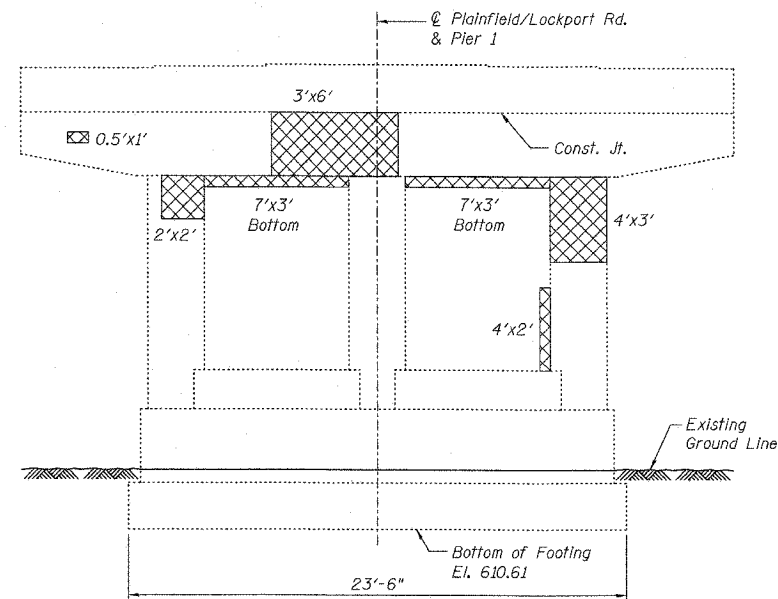

PIER ELEVATION
(Looking East)

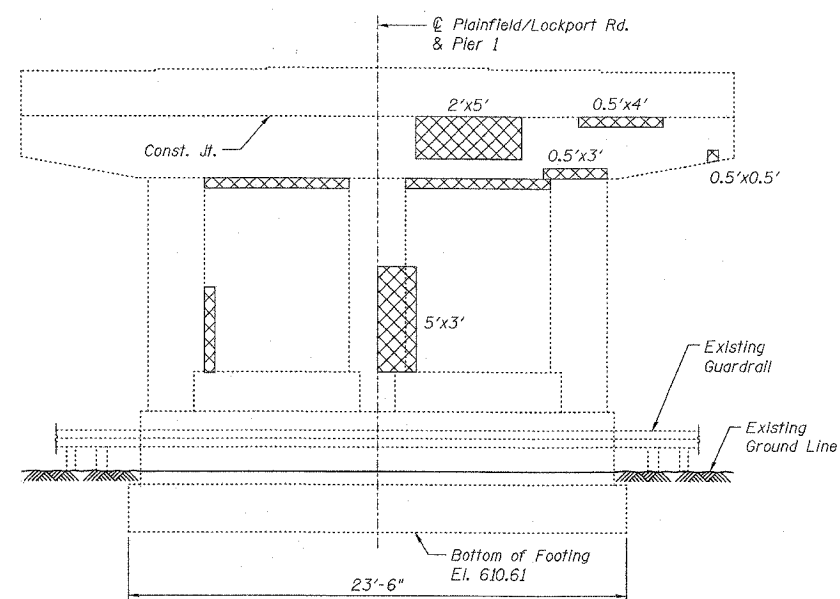

PIER ELEVATION
(Looking West)

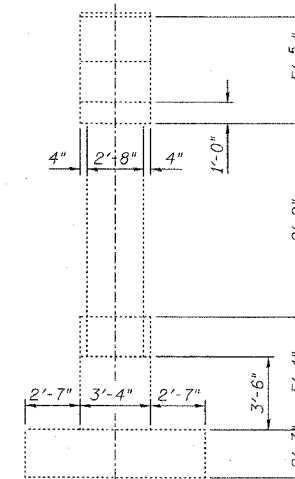

END VIEW
(Looking North)

DESIGNED	S.CHELBIAN
CHECKED	J.GRAINAWI
DRAWN	D.C.PATEL
CHECKED	J.GRAINAWI

Date: 2/23/2007

PIER 1 REPAIR DETAILS
PLAINFIELD ROAD OVER I-55
SECTION 99 (1&2) WRS-1
WILL COUNTY
STA. 699+98.09
STRUCTURE NO. 099-0176



STATE OF ILLINOIS
DEPARTMENT OF TRANSPORTATION

ROUTE NO.	SECTION	COUNTY	TOTAL SHEETS	SHEET NO.
FAI 55	**	WILL	227	148
FED. ROAD DIST. NO. 7				
ILLINOIS				
FED. AID PROJECT-				
** SECTION 99 (1&2) WRS-1				
CONTRACT NO. 62896				

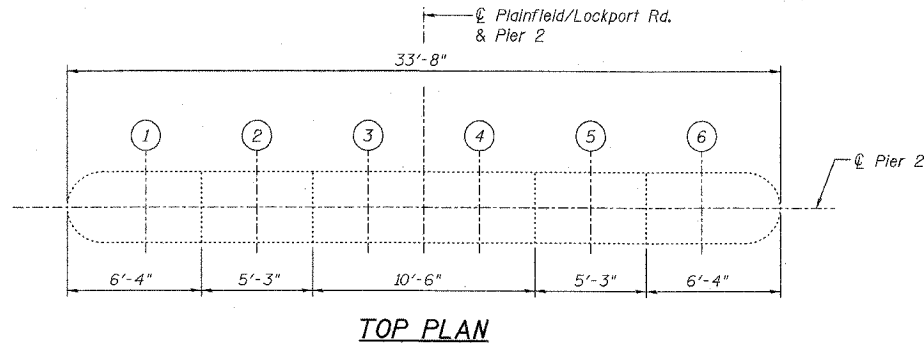
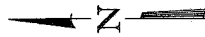

TOP PLAN

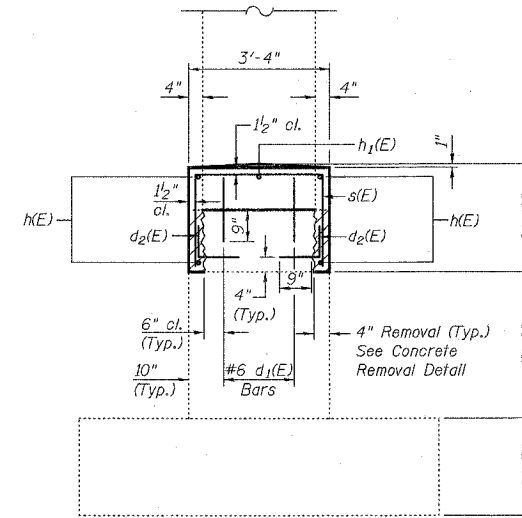

SECTION A-A

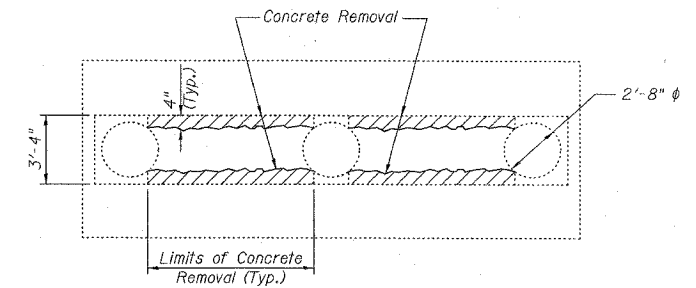

CONCRETE REMOVAL DETAIL
(Only Existing Crashwall Removal Shown)

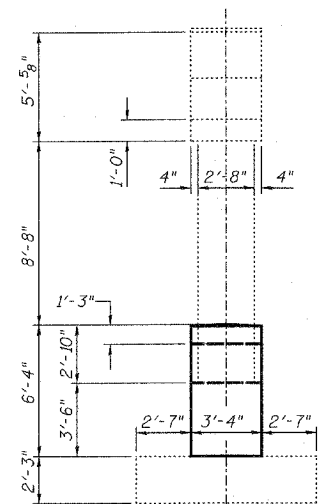

END VIEW
(Looking South)

(Reinforcement Not Shown)

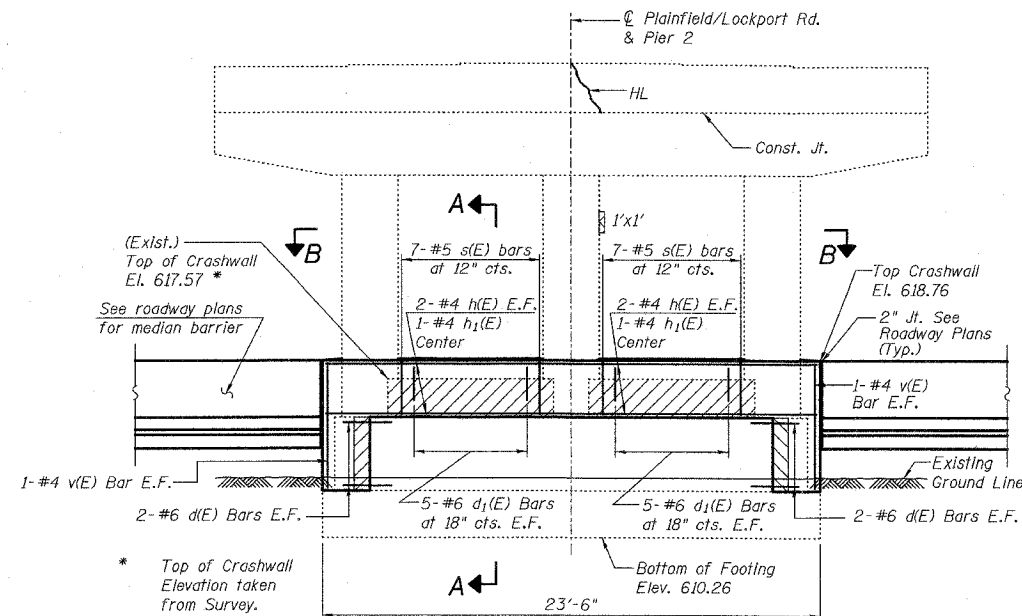

PIER ELEVATION
(Looking East)

(Reinforcement Shown)

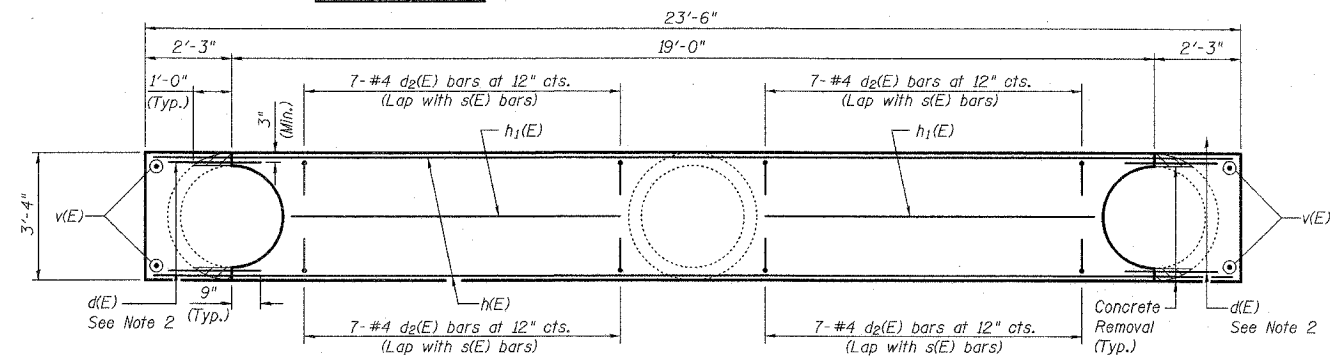

SECTION B-B

Notes:

1. Reinforcement designated "(E)" shall be epoxy coated.
2. Drill and grout #6 d(E), #6 d1(E), & #4 d2(E) in 9" min. drilled holes according to Section 584 of the Standard Specifications. Method and grout are subject to the approval of the Engineer. Cost included with Reinforcement Bars, Epoxy Coated.
3. Existing reinforcement extending into the removal area shall be cleaned, straightened, and incorporated into the new construction. Any reinforcement bars that are damaged during concrete removal shall be replaced with an approved bar splicer or anchorage system. Cost shall be included with Concrete Removal.

LEGEND

- Structural Repair of Concrete (Depth equal to or less than 5")
- Concrete Removal
- H.L. Hairline Crack - Not to be sealed

BILL OF MATERIAL

Bar	No.	Size	Length	Shape
d(E)	8	#6	2'-9"	—
d1(E)	20	#6	1'-9"	—
d2(E)	28	#4	2'-7"	—
h(E)	4	#4	23'-3"	—
h1(E)	2	#4	6'-7"	—
v(E)	4	#4	6'-0"	—
s(E)	14	#5	8'-1"	—
Item		Unit	Total	
Concrete Structures		Cu. Yd.	6.6	
Concrete Removal		Cu. Yd.	0.9	
Reinforcing Bars, Epoxy Coated		Pound	340	
Structural Repair of Concrete (Depth Equal to or Less Than 5")		Sq. Ft.	29.0	

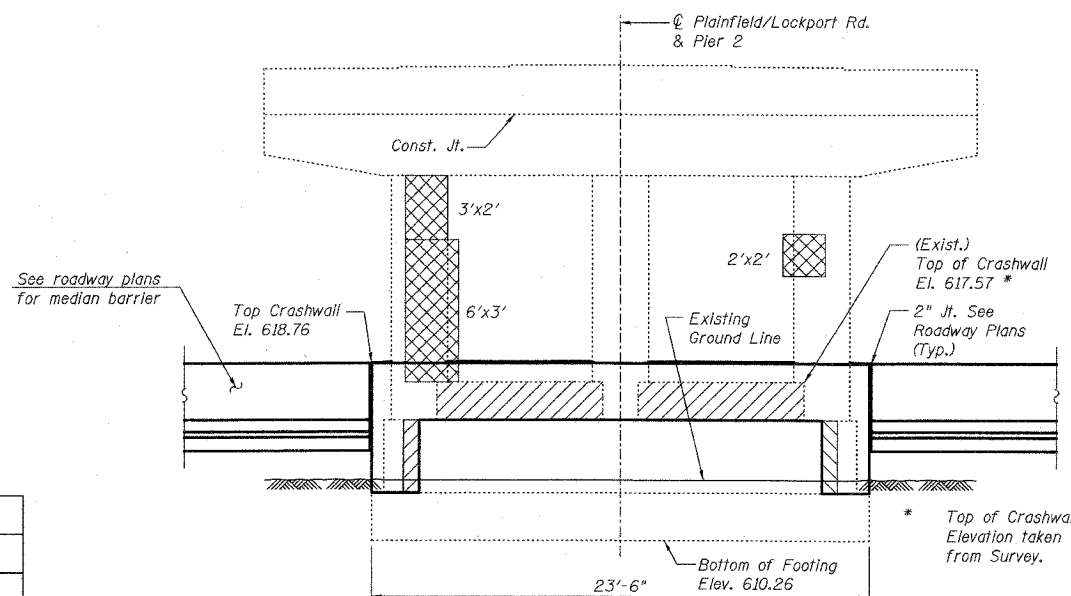

PIER ELEVATION
(Looking West)

(Reinforcement Not Shown)

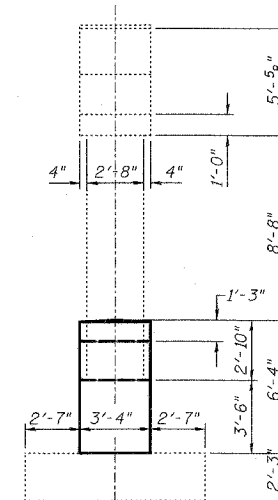

END VIEW
(Looking North)

(Reinforcement Not Shown)

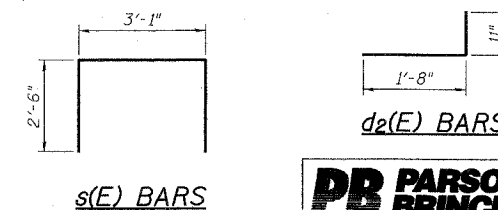

s(E) BARS

d2(E) BARS



PIER 2 REPAIR DETAILS
PLAINFIELD ROAD OVER I-55
SECTION 99 (1&2) WRS-1
WILL COUNTY
STA. 699+98.09
STRUCTURE NO. 099-0176

DESIGNED	S.CHELBIAN
CHECKED	J.GRAINAWI
DRAWN	D.C.PATEL
CHECKED	J.GRAINAWI

Date: 2/23/2007

STATE OF ILLINOIS
DEPARTMENT OF TRANSPORTATION

ROUTE NO.	SECTION	COUNTY	TOTAL SHEETS	SHEET NO.	SHEET NO.
FAI 55	**	WILL	227	149	5 SHEETS
FED. ROAD DIST. NO. 7		ILLINOIS	FED. AID PROJECT-		
** SECTION 99 (1&2) WRS-1 CONTRACT NO. 62896					

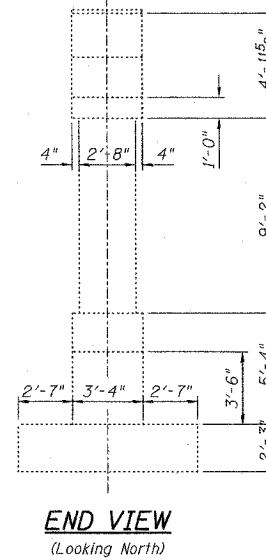
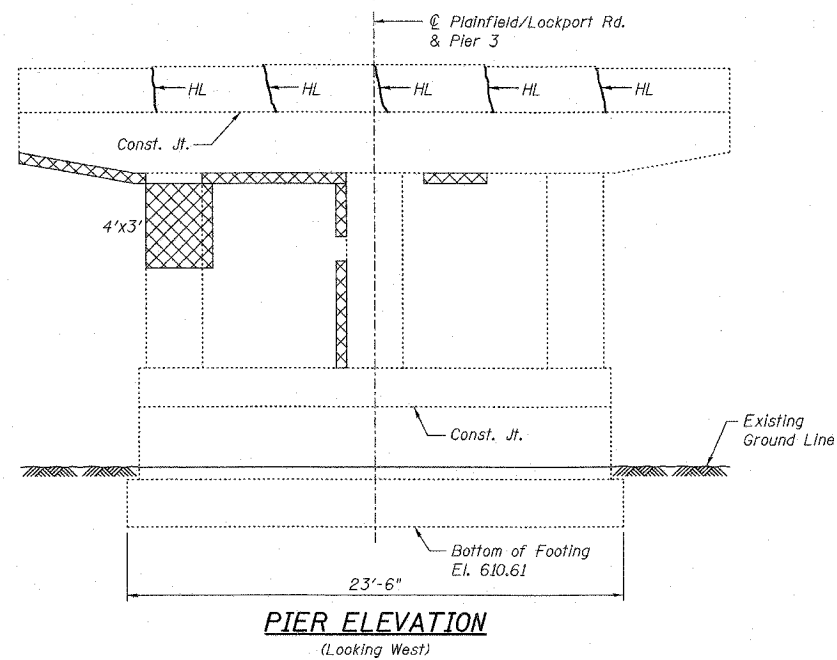
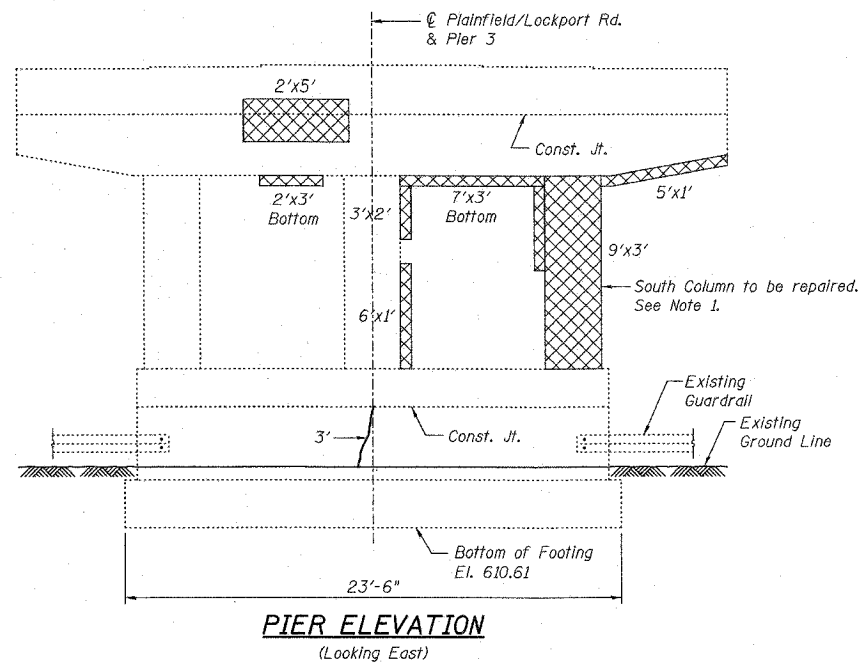
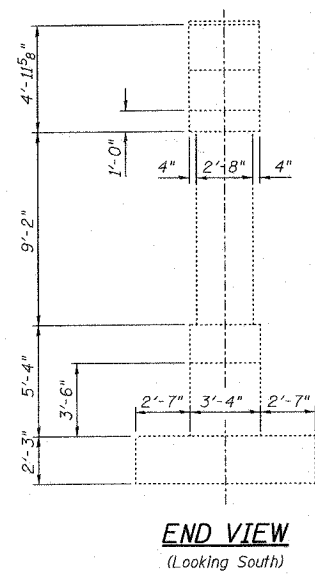
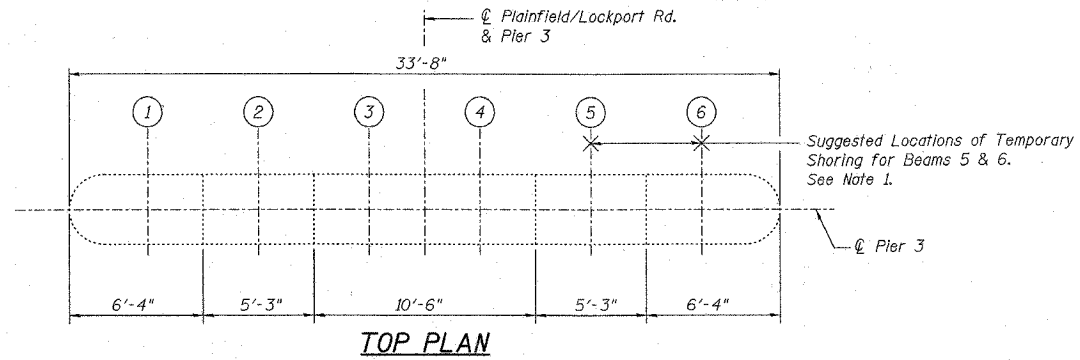
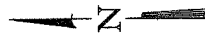

DESIGNED	S.CHELBIAN
CHECKED	J.GRAINAWI
DRAWN	D.C.PATEL
CHECKED	J.GRAINAWI

Date: 2/23/2007

BILL OF MATERIAL

Item	Unit	Total
Structural Repair of Concrete (Depth Equal to or Less Than 5")	Sq. Ft.	93.0
Epoxy Crack Sealing	Foot	3
Temporary Shoring and Cribbing	L.S.	1

LEGEND

- Structural Repair of Concrete (Depth equal to or less than 5")
- Epoxy Crack Sealing
- H.L. Hairline Crack - Not to be sealed

Note:

1. Provide Temporary Shoring to support Beams 5 & 6 during the repair of the south column. See Special Provision for "Temporary Shoring and Cribbing".

PIER 3 REPAIR DETAILS
PLAINFIELD ROAD OVER I-55
SECTION 99 (1&2) WRS-1
WILL COUNTY
STA. 699+98.09
STRUCTURE NO. 099-0176



F.A.I. RTE.	SECTION	COUNTY	TOTAL SHEETS	SHEET NO.
55	99 (1&2) WRS-1	WILL	227	150
STA.		TO STA.		
FED. ROAD DIST. NO.	ILLINOIS	FED. AID PROJECT		

GENERAL NOTES - PREFORMED JOINT FILLER SHALL BE INCLUDED IN THE CONTRACT UNIT PRICE FOR CONCRETE BARRIER TRANSITION.

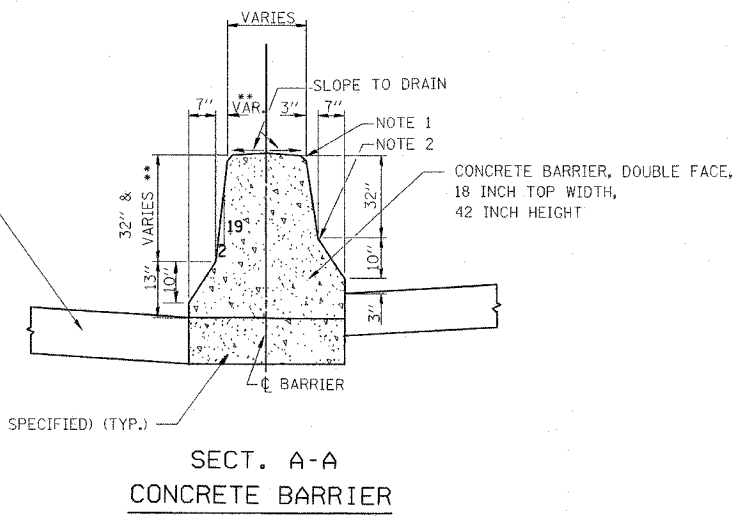
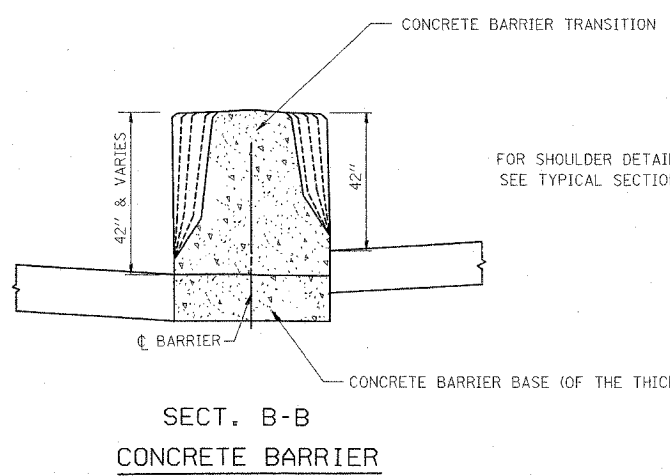
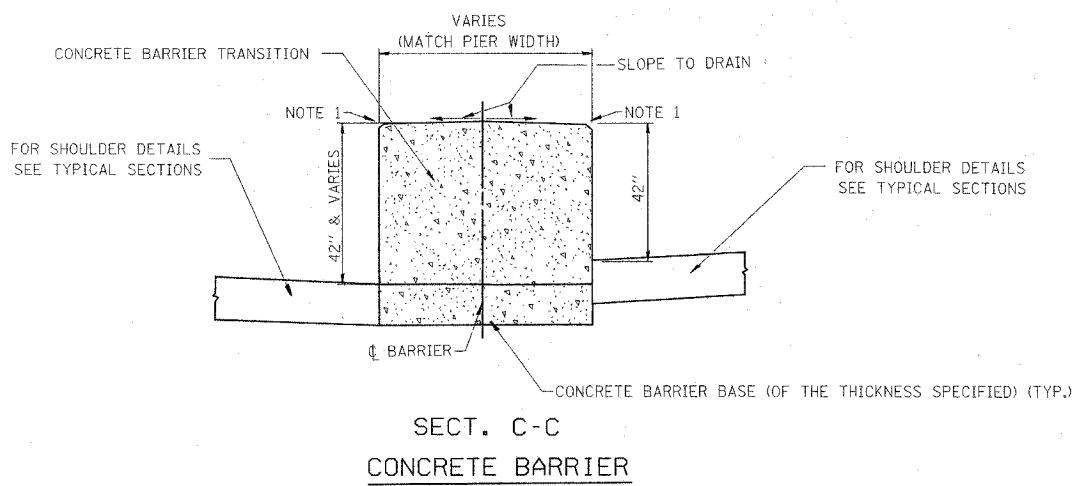
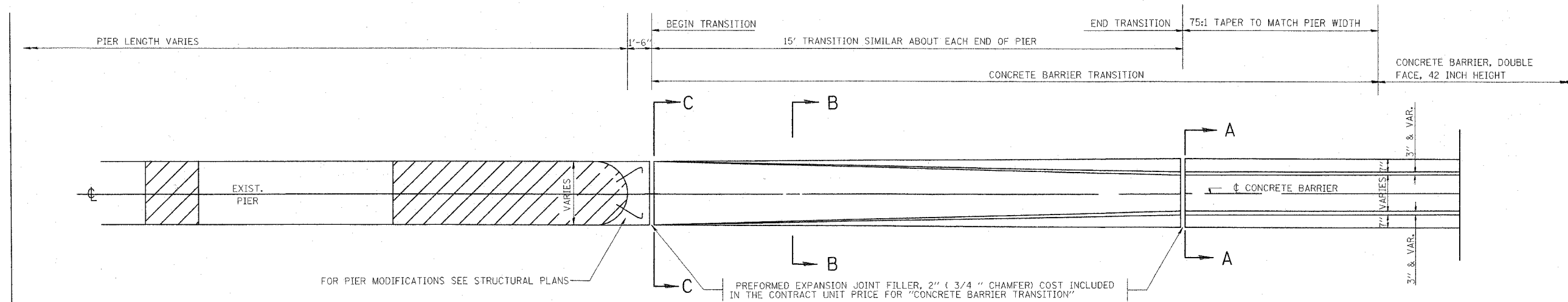

NOTE 1 - 3/4" CHAMFER OR 1" RADIUS (OPTIONAL)
NOTE 2 - 10" RADIUS (OPTIONAL)

** MAINTAIN SLOPE OF FACE AS SHOWN ON DETAIL. HEIGHT AND WIDTH OF BARRIER INCREASE WHERE A DIFFERENCE IN MEDIAN EDGE-OF-PAVEMENT GRADE ELEVATION EXISTS.

REVISIONS	
NAME	DATE

ILLINOIS DEPARTMENT OF TRANSPORTATION
FAI ROUTE 55
US 30 (PLAINFIELD ROAD) TO 143RD STREET

CONCRETE BARRIER
TRANSITION DETAIL

SCALE: 1" = 50'
DATE: 02-23-07
DRAWN BY
CHECKED BY



F.A. RTE.	SECTION	COUNTY	TOTAL SHEETS	SHEET NO.
55			227	151
STA.		TO STA.		
FED. ROAD DIST. NO.		ILLINOIS FED. AID PROJECT		

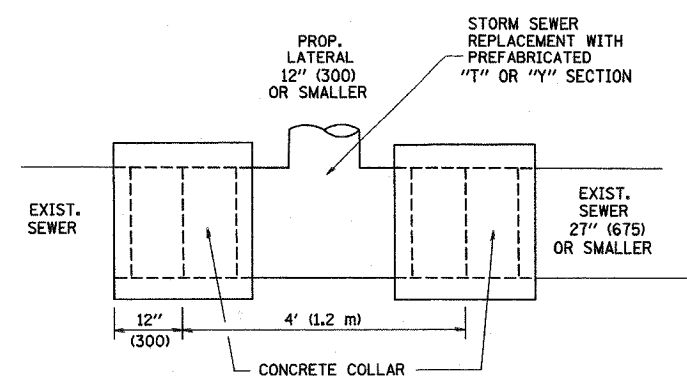

DETAIL "A"
LATERAL CONNECTION TO EXISTING SEWER OF 27" (675) OR SMALLER

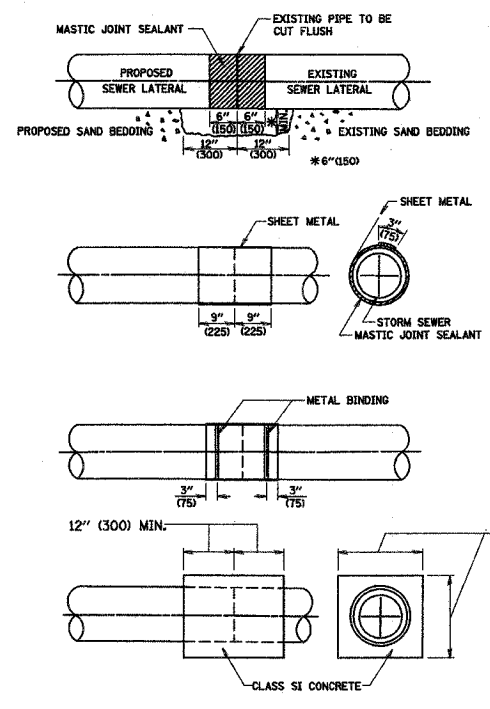

DETAIL "B"
CLASS SI CONCRETE COLLAR

CONSTRUCTION SEQUENCE

- CUT THE EXISTING END OF THE PIPE SO AS TO PRESENT A FLUSH BUTT JOINT. BRUSH AND CLEAN ALL PIPES.
- APPLY THE MASTIC JOINT SEALANT TO THE FIRST 6" (150) OF EACH PIPE.
- BUTT THE PIPES TOGETHER LEAVING A MINIMUM OF 12" x 6" (300 x 150) DEEP EXCAVATION UNDER AND AROUND EACH PIPE END.
- CUT A PIECE OF SHEET METAL GAGE NO. 19 1.1 (0.0418) 18" (450) WIDE BY THE OUTSIDE CIRCUMFERENCE OF THE PIPE PLUS 3" (75) LONG.
- WRAP THE SHEET METAL AROUND THE PIPES, 9" (225) ON EACH SIDE OF THE JOINT, STARTING AT THE TOP OF THE PIPE.
- LAP THE SHEET METAL AT LEAST 3" (75) AT THE TOP OF THE PIPE AND PLACE THE MASTIC JOINT SEALANT BETWEEN THE LAP.
- PLACE TWO METAL BANDS AROUND THE SHEET METAL AND TIGHTEN.
- WIPE OFF ANY EXCESS MASTIC JOINT SEALANT THAT OZZES OUT FROM BETWEEN THE SHEET METAL AND THE PIPES.
- PLACE CLASS SI CONCRETE AROUND THE JOINT.

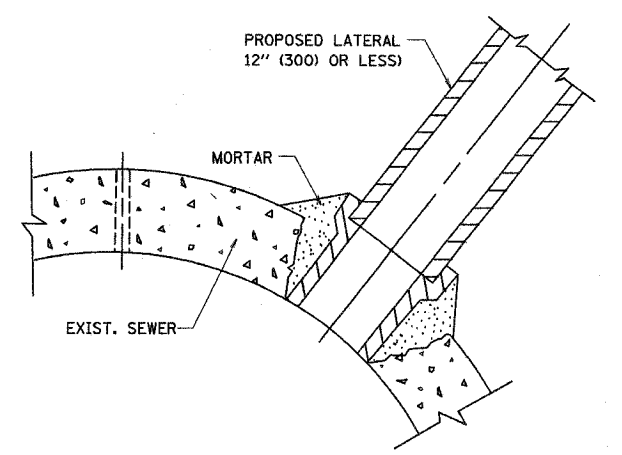

DETAIL "C"
PROPOSED LATERAL CONNECTION TO EXISTING SEWER OF 30" (750) OR LARGER

NOTES

MATERIAL

MATERIAL USED FOR THE TEE OR WYE SECTION SHALL BE COMPATIBLE WITH THE EXISTING STORM SEWER OR THE PROPOSED STORM SEWER.

CONSTRUCTION METHODS

I THIS WORK SHALL BE CONSTRUCTED IN CONFORMANCE WITH THE APPLICABLE PORTIONS OF SECTION 550 OF THE STANDARD SPECIFICATIONS.

II CONNECTION TO AN EXISTING STORM SEWER SHALL BE BY EITHER OF THE FOLLOWING METHODS:

- A) PROPOSED STORM SEWER CONNECTION TO EXISTING SEWER OF 27" (675) OR SMALLER SEE DETAIL "A" AND "B".
- B) PROPOSED STORM SEWER CONNECTION TO EXISTING SEWER OF 30" (750) OR LARGER SEE DETAIL "C".

IF THE EXISTING SEWER PIPE IS CRACKED, BROKEN OR OTHERWISE DAMAGED BY THE CONTRACTOR IN MAKING THE CIRCULAR OPENING, THE CONTRACTOR SHALL REPLACE THAT SECTION OF PIPE WITH PIPE EQUAL AND SIMILAR IN ALL RESPECTS TO THE PIPE IN THE EXISTING SEWER, IN A CAREFUL WORKMANLIKE MANNER, WITHOUT EXTRA COMPENSATION.

GENERAL

CARE MUST BE TAKEN TO PREVENT DEBRIS FROM ENTERING THE SEWER. ALL DEBRIS WHICH ENTERS THE SEWER MUST BE REMOVED. THE SEWER MUST BE LEFT CLEAN AND UNOBSTRUCTED UPON COMPLETION OF THE CONTRACT.

CARE MUST BE TAKEN TO PREVENT ANY PART OF THE NEW PIPE CONNECTION FROM PROJECTING INTO THE EXISTING SEWER.

BASIS OF PAYMENT

TEE OR WYE CONNECTIONS SHALL BE PAID FOR AT THE CONTRACT UNIT PRICE EACH FOR STORM SEWER TEE OR WYE OF THE TYPE AND SIZE SPECIFIED IN THE PLANS, THIS PRICE SHALL INCLUDE ALL EXCAVATION OF THE TRENCH, REMOVAL OF THE EXISTING STORM SEWER, FURNISHING AND INSTALLING THE SPECIFIED TEE OR WYE SECTION, FURNISHING AND INSTALLING THE REQUIRED CONCRETE COLLAR, AND ALL OTHER MATERIAL NECESSARY TO COMPLETE THIS WORK AS SHOWN AND SPECIFIED.

REMOVAL AND REINSTALLATION OF EXISTING STORM SEWER ADJACENT TO THE PROPOSED TEE OR WYE SECTION, FOR THE PURPOSE OF FACILITATING THE INSTALLATION OF THE TEE OR WYE SECTION, WILL NOT BE PAID FOR SEPARATELY BUT SHALL BE INCLUDED IN THE UNIT PRICE BID FOR THE WORK.

TRENCH BACKFILL, EXCAVATION IN ROCK AND REMOVAL AND REPLACEMENT OF UNSUITABLE MATERIAL BELOW PLAN BEDDING GRADE WILL BE PAID FOR SEPARATELY.

CONCRETE COLLAR FOR CONNECTING A PROPOSED STORM SEWER TO AN EXISTING STORM SEWER WILL NOT BE PAID FOR SEPARATELY BUT SHALL BE INCLUDED IN THE COST OF THE PROPOSED STORM SEWER.

ALL DIMENSIONS ARE IN INCHES (MILLIMETERS) UNLESS OTHERWISE SHOWN.

REVISIONS	
NAME	DATE
M. DE YONG	07/25/90
M. DE YONG	02/05/92
M. DE YONG	05/08/92
R. SHAH	09/09/94
R. SHAH	10/25/94
R. SHAH	06/12/96

ILLINOIS DEPARTMENT OF TRANSPORTATION
DETAIL OF STORM SEWER CONNECTION TO EXISTING SEWER

SCALE: VERT. _____
HORIZ. _____
DATE: 1/18/2007

DRAWN BY _____
CHECKED BY _____
BD500-01 (BD-7)
REVISION DATE: 01/01/07

PLOT DATE = 1/18/2007
FILE NAME = c:\p\pro\mca\data\stsd\bd500.dgn
PLOT SCALE = 1/8" = 1' / IN.
USER NAME = drvrkocgn

F.A. RTE.	SECTION	COUNTY	TOTAL SHEETS	SHEET NO.
55			227	152
STA.		TO STA.		
FED. ROAD DIST. NO. 1 ILLINOIS FED. AID PROJECT				

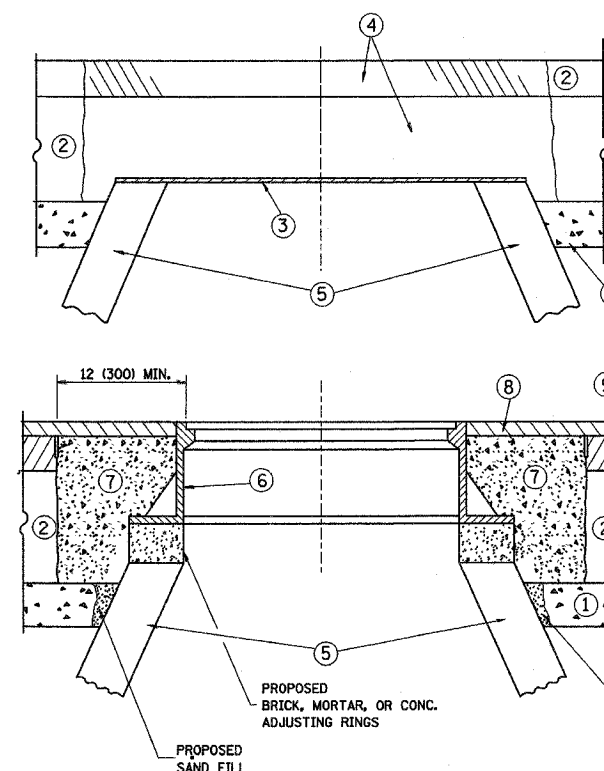

CONSTRUCTION PROCEDURES

STAGE 1 (BEFORE PAVEMENT MILLING)

- A) REMOVE A MINIMUM OF 12 (300) OF THE PAVEMENT FROM AROUND THE STRUCTURE.
- B) REMOVE THE EXISTING FRAME AND LID FROM THE STRUCTURE.
- C) COVER THE STRUCTURE OPENING WITH A 36 (900) DIAMETER METAL PLATE.
- D) BACKFILL WITH CRUSHED STONE AND A MINIMUM 1/2 (40) THICK HMA SURFACE MIX APPROVED BY THE ENGINEER.

STAGE 2 (AFTER PAVEMENT MILLING)

- A) REMOVE THE HMA SURFACE MIX AND CRUSHED STONE.
- B) INSTALL THE FRAME AND LID; ADJUST THE FRAME TO ITS FINAL SURFACE ELEVATION.
- C) THE SURROUNDING SPACE SHALL BE FILLED WITH CLASS SI CONCRETE, OR HMA SURFACE COURSE OR HMA BINDER COURSE TO THE ELEVATION OF THE SURFACE OF THE EXISTING BASE COURSE OR THE BINDER COURSE.

THE PROCEDURE EXPLAINED ABOVE SHALL CONFORM TO THE APPLICABLE PORTIONS OF SECTIONS 353, 406, 602, AND 603 OF THE STANDARD SPECIFICATIONS.

LEGEND

- ① SUB-BASE GRANULAR MATERIAL
- ② EXISTING PAVEMENT
- ③ 36 (900) DIAMETER METAL PLATE
- ④ PROPOSED CRUSHED STONE AND HMA SURFACE MIX
- ⑤ EXISTING STRUCTURE
- ⑥ FRAME AND LID (SEE NOTES)
- ⑦ CLASS SI CONCRETE, HMA SURFACE COURSE OR HMA BINDER COURSE
- ⑧ PROPOSED HMA SURFACE COURSE
- ⑨ PROPOSED HMA BINDER COURSE

NOTES:

EXISTING BROKEN FRAMES AND LIDS SHALL BE REMOVED AND DISPOSED OF BY THE CONTRACTOR AND SHALL BE REPLACED AS DIRECTED BY THE ENGINEER. REPLACEMENT FRAMES AND LIDS WILL BE PAID FOR IN ACCORDANCE WITH ARTICLE 109.04 OF THE STANDARD SPECIFICATIONS UNLESS A SEPARATE PAY ITEM HAS BEEN PROVIDED.

IF THE EXISTING LIDS ARE OPEN, THE FRAME WILL BE ADJUSTED TO THE ELEVATION OF THE MILLED PAVEMENT SURFACE PRIOR TO THE MILLING OPERATION. THE FRAME WILL NOT BE REMOVED AND COVERED BY THE METAL PLATE.

CITY OF CHICAGO CASTINGS ARE THE PROPERTY OF THE CITY AND THE CONTRACTOR SHALL NOTIFY THE CITY FOR REMOVAL AND DISPOSITION OF THE CASTINGS.

THE METAL PLATE USED TO COVER THE STRUCTURE SHALL REMAIN THE PROPERTY OF THE CONTRACTOR.

WHEN STRUCTURES ARE TO BE ADJUSTED OR RECONSTRUCTED, THE LOWERING AND RAISING OF THE FRAMES AND LIDS WILL NOT BE PAID FOR SEPARATELY BUT WILL BE INCLUDED IN THE COST OF THE CORRESPONDING PAY ITEM.

LOCATION OF STRUCTURES:

THE CONTRACTOR WILL BE REQUIRED TO KEEP A RECORD OF THE LOCATIONS OF THE BURIED STRUCTURES ACCORDING TO THE STATION AND DISTANCE LEFT OR RIGHT OF THE CENTERLINE OF PAVEMENT. UPON COMPLETION OF THE WORK, THE CONTRACTOR WILL DELIVER THE RECORD TO THE ENGINEER.

BASIS OF PAYMENT: THIS WORK WILL BE PAID FOR AT THE CONTRACT UNIT PRICE PER EACH FOR "FRAMES AND LIDS TO BE ADJUSTED, SPECIAL"

NEW FRAMES AND LIDS, WHEN SPECIFIED, WILL BE PAID FOR SEPARATELY.

DETAILS FOR FRAMES AND LIDS ADJUSTMENT WITH MILLING

ALL DIMENSIONS ARE IN INCHES (MILLIMETERS) UNLESS OTHERWISE SHOWN

REVISIONS	
NAME	DATE
R. SHAH	10/25/94
R. SHAH	01/30/95
R. SHAH	03/10/95
A. ABBAS	03/21/97
R. WIEDEMAN	05/14/04
R. BORO	01/01/07

ILLINOIS DEPARTMENT OF TRANSPORTATION
DETAILS FOR FRAMES AND LIDS ADJUSTMENT WITH MILLING

SCALE: VERT. NONE
HORIZ. NONE
PLOT DATE: 1/18/2007

DRAWN BY
CHECKED BY

BD600-03 (BD-8)
REVISION DATE: 01/01/07

DATE = 1/18/2007
FILE NAME = c:\proje\msh\detail\bd600.dgn
PLOT SCALE = 1/8"=1'-0"
USER NAME = drakekong

F.A. RTE.	SECTION	COUNTY	TOTAL SHEETS	SHEET NO.
55			227	153
STA.		TO STA.		
FED. ROAD DIST. NO. 1		ILLINOIS FED. AID PROJECT		

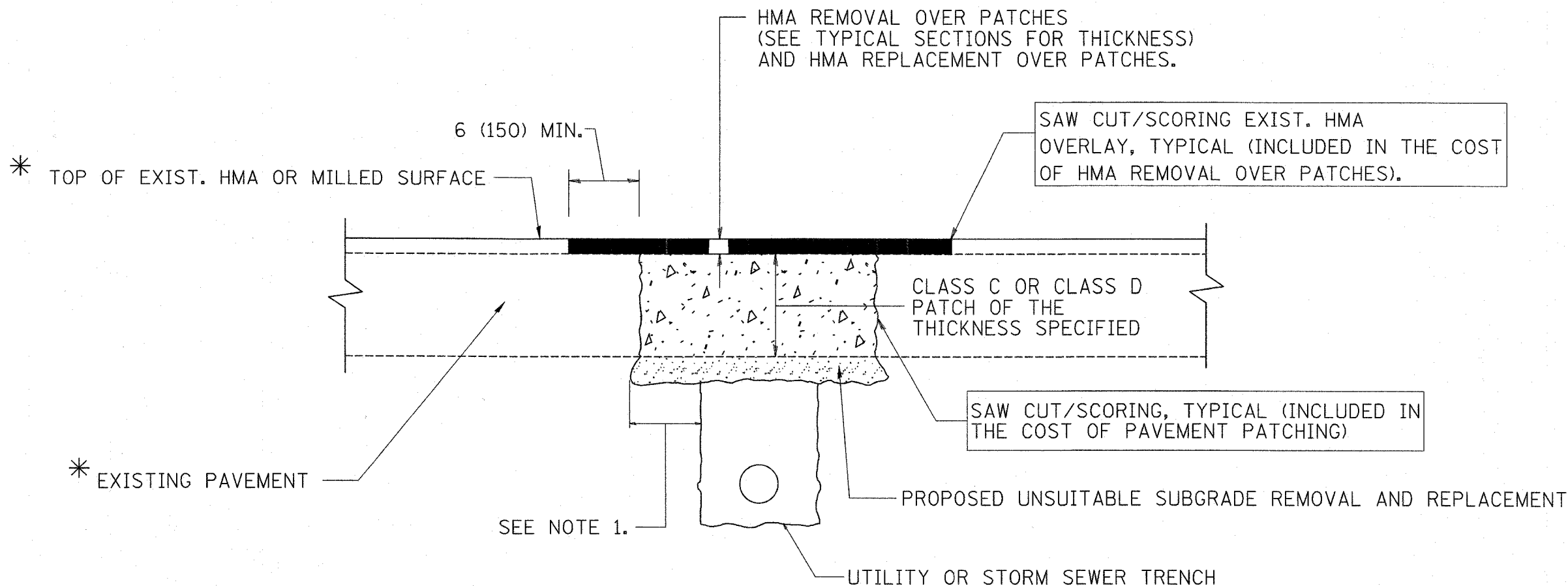

* SEE TYPICAL SECTIONS FOR THICKNESS AND MATERIALS

NOTES:

1. THE WIDTH OF THE FULL DEPTH PATCH OVER A TRENCH SHALL BE 12 (300) WIDER ON EACH SIDE OF THE TRENCH.
2. FOR METHOD OF MEASUREMENT AND BASIS OF PAYMENT, SEE RECURRING SPECIAL PROVISION "PATCHING WITH HOT-MIX ASPHALT OVERLAY REMOVAL".

SEQUENCE OF CONSTRUCTION

1. REMOVE THE EXISTING HMA MATERIAL OVER THE AREA TO BE PATCHED.
2. REMOVE AND REPLACE FULL DEPTH PATCHES
3. REPLACE HMA MATERIAL OVER THE AREA TO BE PATCHED.

ALL DIMENSIONS ARE IN INCHES (MILLIMETERS) UNLESS OTHERWISE SHOWN.

REVISIONS	
NAME	DATE
R. SHAH	10/25/94
R. SHAH	01/14/95
R. SHAH	03/23/95
R. SHAH	04/24/95
A. HOUSEH	03/15/96
A. ABBAS	03/21/97
A. ABBAS	01/20/98
ART ABBAS	04/27/98
R. BORO	01/01/07

ILLINOIS DEPARTMENT OF TRANSPORTATION

PAVEMENT PATCHING FOR HMA SURFACED PAVEMENT

SCALE: VERT. NONE
HORIZ. 1/18/2007
PLOT DATE: 1/18/2007

DRAWN BY
CHECKED BY

BD400-04 (BD-22)

REVISION DATE: 01/01/07

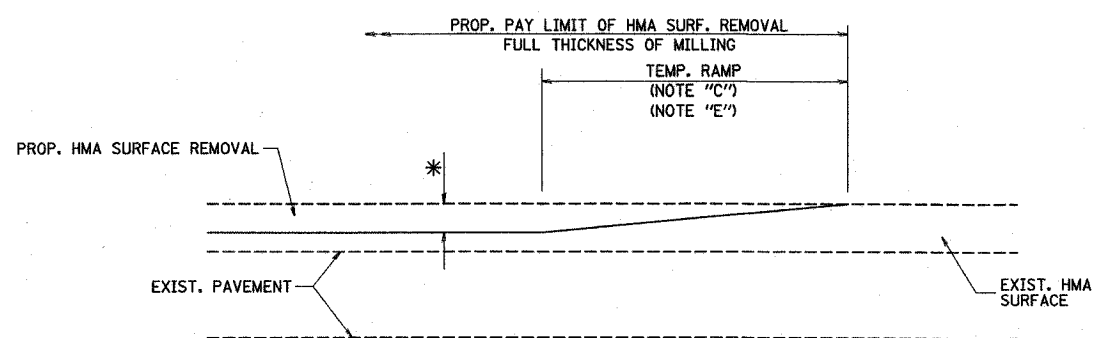

MILLED TEMPORARY RAMP
(FOR BUTT JOINT AND HMA TAPER SEE DETAIL BELOW)

OPTION 1

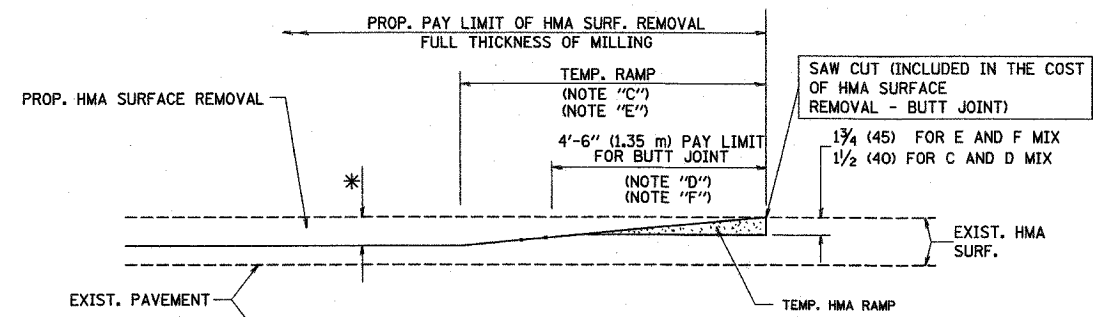

HMA CONSTRUCTED TEMPORARY RAMP
(FOR BUTT JOINT AND HMA TAPER SEE DETAIL BELOW)

OPTION 2
TYPICAL TEMPORARY RAMP

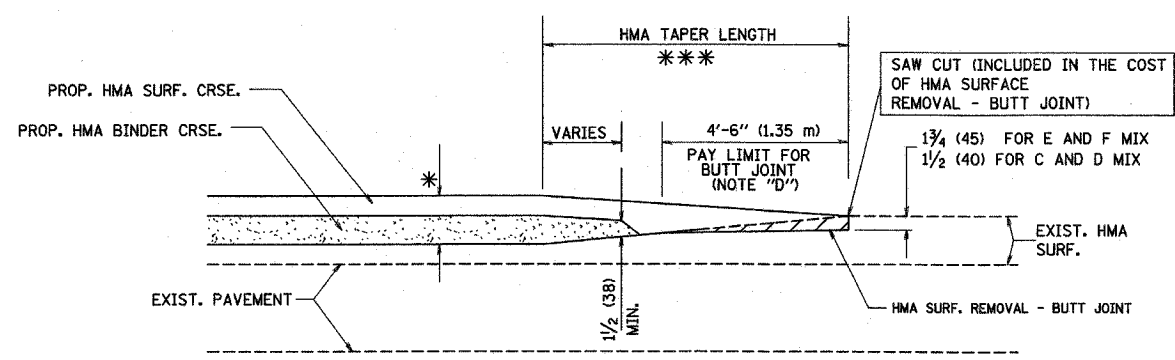

BUTT JOINT AND HMA TAPER
TYPICAL BUTT JOINT AND HMA TAPER
FOR MILLING AND RESURFACING

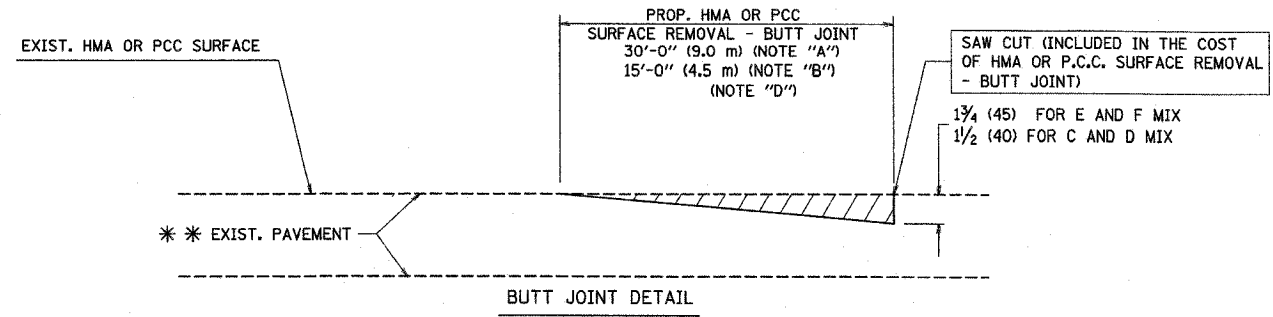

BUTT JOINT DETAIL

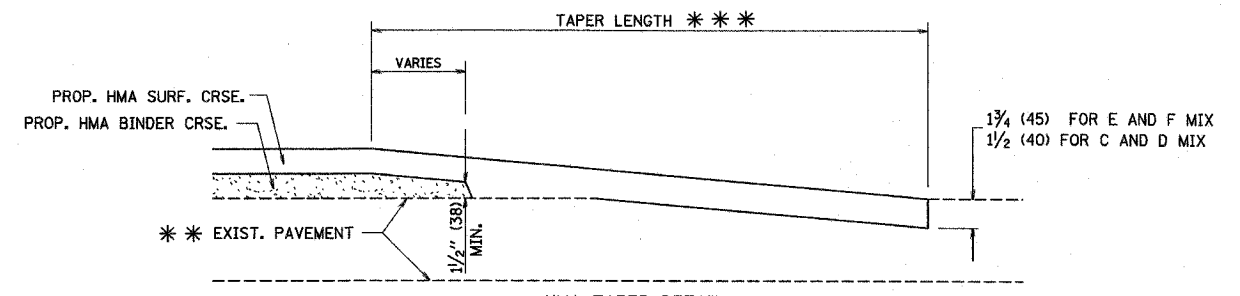

HMA TAPER DETAIL

TYPICAL BUTT JOINT AND HMA TAPER
FOR RESURFACING ONLY

*** PC CONCRETE, HMA OR HMA RESURFACED PAVEMENT.

NOTES

- A: MAINLINE ROADWAYS AND MAJOR SIDE ROADS.
- B: MINOR SIDE ROADS.
- C: THE TEMP. RAMP SHALL BE CONSTRUCTED IMMEDIATELY UPON REMOVAL OF THE EXISTING HMA SURFACE.
- D: THE BUTT JOINT SHALL BE CONSTRUCTED IMMEDIATELY PRIOR TO PLACING THE PROPOSED HMA COURSES.
- E: TAPER THE TEMP. RAMP AT A RATE OF 3'-0" (900 mm) PER 1 INCH (25 mm) OF MILLING THICKNESS.
- F: INSTALLATION AND REMOVAL OF THE 4'-6" (1.35 m) TEMP. RAMP IS INCLUDED IN COST OF HMA SURFACE REMOVAL - BUTT JOINT
- G: SEE ARTICLE 406.08 AND 406.14 OF THE STANDARD SPECIFICATIONS FOR "HMA AND/OR PCC SURFACE REMOVAL, BUTT JOINT".
- * SEE TYPICAL SECTIONS FOR MILLING THICKNESS.
- *** 20'-0" (6.1 m) PER 1 (25) RESURFACING (NOTE "A")
10'-0" (3.0 m) PER 1 (25) RESURFACING (NOTE "B")

ALL DIMENSIONS ARE IN INCHES (MILLIMETERS) UNLESS OTHERWISE SHOWN.

BASIS OF PAYMENT:

THE BUTT JOINT WILL BE PAID FOR AT THE CONTRACT UNIT PRICE PER SQUARE YARD (SQUARE METER) FOR "HOT-MIX ASPHALT SURFACE REMOVAL - BUTT JOINT" OR FOR "PORTLAND CEMENT CONCRETE SURFACE REMOVAL - BUTT JOINT".

REVISIONS	
NAME	DATE
M. DE YONG	6-13-90
M. DE YONG	7-3-90
M. DE YONG	3-27-92
R. SHAH	09/09/94
R. SHAH	10/25/94
A. ABBAS	03/21/97
M. GOMEZ	04/06/01
R. BORO	01/01/07

ILLINOIS DEPARTMENT OF TRANSPORTATION

BUTT JOINT AND HMA TAPER DETAILS

SCALE: VERT. NONE
HORIZ. 1/8" = 1'-0"
PLOT DATE: 1/18/2007

DRAWN BY
CHECKED BY

BD400-05 (VI-BD32)
REVISION DATE: 01/01/07

PLOT DATE = 1/18/2007
 PLOT SCALE = 3/8" = 1'-0"
 USER NAME = drvalkong

CONTRACT NO. 62896				
F.A. RTE.	SECTION	COUNTY	TOTAL SHEETS	SHEET NO.
55			227	155
STA.		TO STA.		
FED. ROAD DIST. NO. 1 ILLINOIS FED. AID PROJECT				

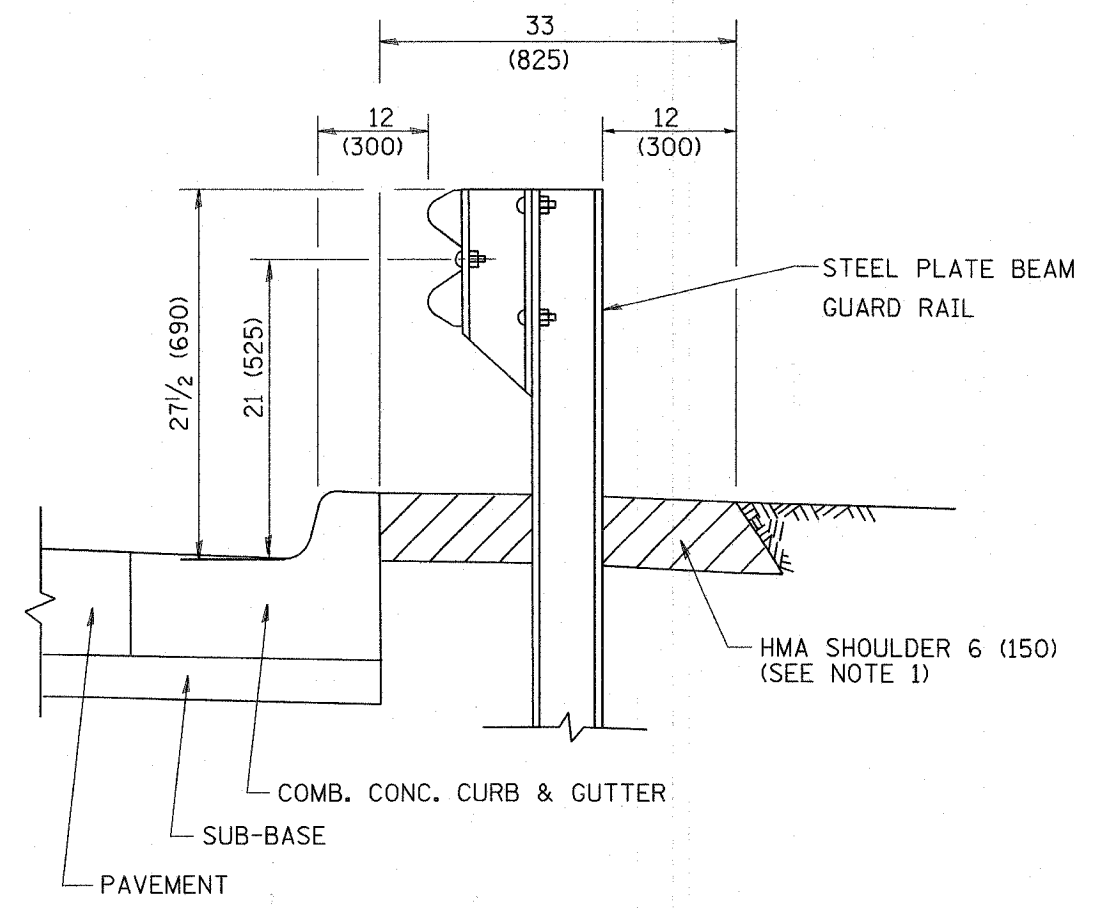

- NOTES:
1. THE HMA SHOULDER SHALL EXTEND UNDER THE TRAFFIC BARRIER TERMINAL
 2. GUARD RAIL MAY BE PLACED AT THE BACK OF CURB WHEN DIRECTED BY THE ENGINEER.

BASIS OF PAYMENT: HMA SHOULDER 6 (150) WILL BE PAID FOR AT THE CONTRACT UNIT PRICE PER SQUARE YARD (SQUARE METER) FOR "HOT-MIX ASPHALT SHOULDER 6" (150 mm)".

STEEL PLATE BEAM GUARD RAIL AND TRAFFIC BARRIER TERMINAL, OF THE TYPE SPECIFIED WILL BE PAID FOR SEPARATELY.

**DETAILS FOR STEEL PLATE BEAM
GUARD RAIL ADJACENT TO CURB AND GUTTER
[FOR ROADWAY SPEED 35 MPH (60 kmh) TO 45 MPH (70 kmh)]**

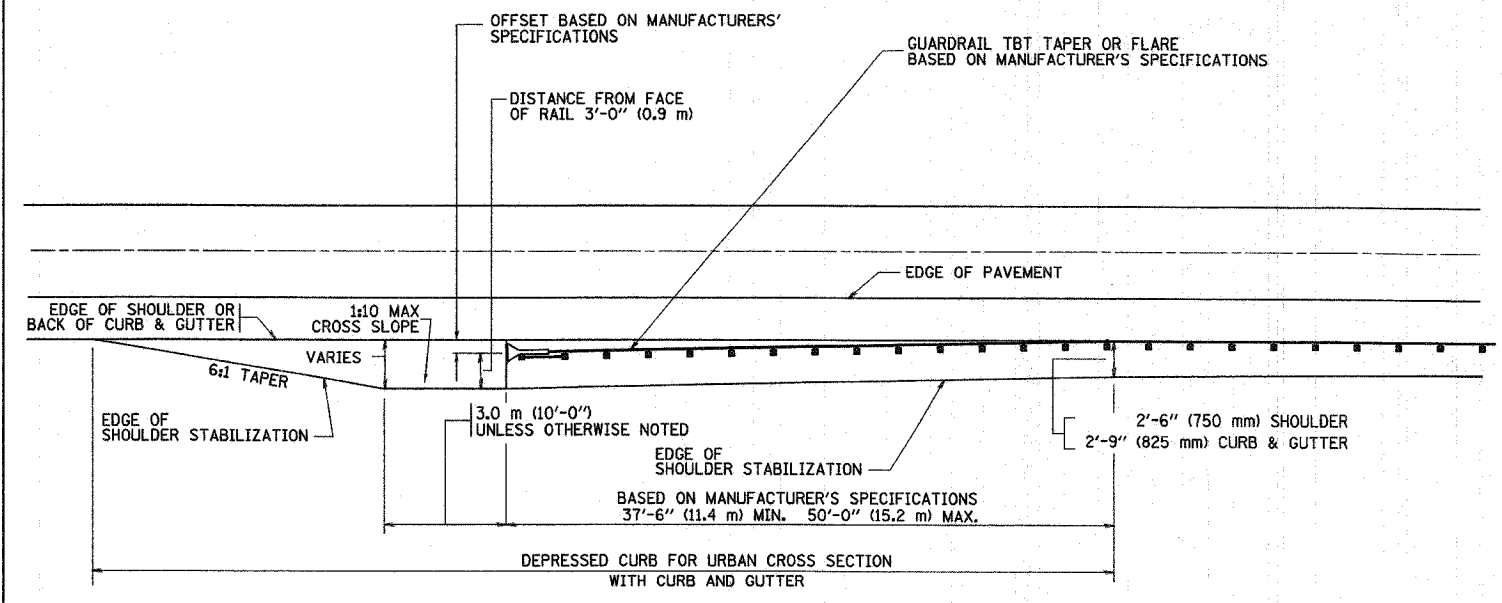

STABILIZATION AT TBT TY. 1 SPL.

TBT = TRAFFIC BARRIER TERMINAL
ALL DIMENSIONS ARE IN INCHES (MILLIMETERS) UNLESS OTHERWISE SHOWN.

REVISIONS	
NAME	DATE
M. DE YONG	09-22-90
M. DE YONG	07-14-92
R. SHAH	09/09/94
R. SHAH	10/25/94
R. SHAH	02/23/95
A. ABBAS	03/21/97
E. GOMEZ	08/28/00
R. BORO	01/01/07

ILLINOIS DEPARTMENT OF TRANSPORTATION
**DETAILS FOR
STEEL PLATE BEAM GUARD RAIL
ADJACENT TO CURB AND GUTTER
STABILIZATION AT TBT TY 1 SPL.**
SCALE: VERT. NONE
HORIZ. NONE
PLOT DATE: 1/18/2007
DRAWN BY: jls
CHECKED BY:

PLOT DATE = 1/18/2007
FILE NAME = c:\p\projects\62896\bd34.dgn
PLOT SCALE = 1/8"=1'-0"
USER NAME = drivecraigh

F.A. RTE.	SECTION	COUNTY	TOTAL SHEETS	SHEET NO.
55			227	156
STA.		TO STA.		
FED. ROAD DIST. NO.		ILLINOIS FED. AID PROJECT		

GENERAL NOTES

ALTERNATE MATERIAL FOR THE WALLS MAY BE CONCRETE MASONRY UNITS, PRECAST REINFORCED CONCRETE SECTIONS OR CAST-IN-PLACE CONCRETE, THE CAST IRON STEPS AS DETAILED HEREON ARE TYPICAL. STEPS OF OTHER DESIGN AND MATERIAL THAT CONFORM TO THE MINIMUM REQUIREMENTS OF THE STEPS SHOWN MAY BE USED WHEN APPROVED BY THE ENGINEER.

CAST IRON STEPS SHALL BE GRAY IRON CONFORMING TO THE REQUIREMENTS OF ARTICLE 1006.14 OF THE STANDARD SPECIFICATIONS.

STEPS SHALL BE EMBEDDED INTO THE WALL A MINIMUM OF THREE (3) INCHES. STEPS SHALL NOT BE EXTENDED ON THE OUTSIDE.

STEPS SHALL BE OMITTED FOR WORK IN COOK COUNTY WHEN THE DEPTH OF THE MANHOLE IS TEN (10') OR LESS.

IN ADDITION TO THE REQUIREMENTS OF ARTICLE 612.13 OF THE STANDARD SPECIFICATIONS, THE CONTRACT UNIT PRICE FOR MANHOLES, TYPE A, 7'-DIAMETER SHALL INCLUDE THE SAND CUSHION WHEN REQUIRED, FURNISHING AND INSTALLING STEPS WHEN REQUIRED, FURNISHING AND COMPACTING THE SPECIFIED BACKFILL MATERIAL, AND FURNISHING AND INSTALLING FLAT SLAB TOP.

PRECAST FLAT SLAB TOP SHALL CONFORM TO ARTICLES 505.01 THRU 505.05 OF THE STANDARD SPECIFICATIONS EXCEPT THAT THE CONCRETE STRENGTH SHALL BE 4,000 PSI AFTER 28 DAYS. REINFORCEMENT BARS AND WELDED WIRE FABRIC SHALL CONFORM TO THE REQUIREMENTS OF ARTICLE 1006.10. ONLY GRADE 60 REINFORCEMENT BARS WILL BE PERMITTED.

BOTTOM SLAB SHALL BE REINFORCED BY EITHER REINFORCEMENT BARS OR WELDED WIRE FABRIC, THE MINIMUM REINFORCEMENT SHALL BE 0.45 SQUARE INCH PER LINEAR FOOT IN BOTH DIRECTIONS.

JOINT CONFIGURATION AND DIMENSIONS OF FLAT SLAB TOP SHALL MATCH AND FIT THE RISER JOINT DETAIL.

LIFTING DEVICES SHALL BE APPROVED BY THE ENGINEER.

ALTERNATE MATERIALS FOR RISERS	T (MIN.)
CONCRETE MASONRY UNITS	5"
PRECAST REINFORCED CONCRETE SECTIONS	4"
CAST-IN-PLACE CONCRETE	6"

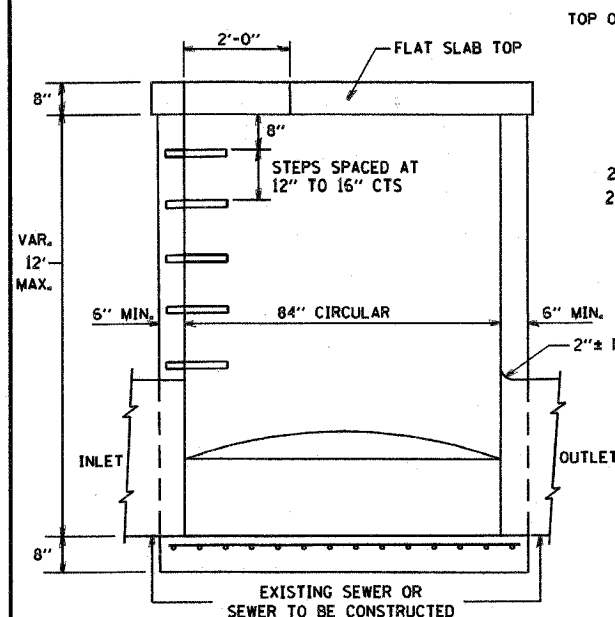

ELEVATION

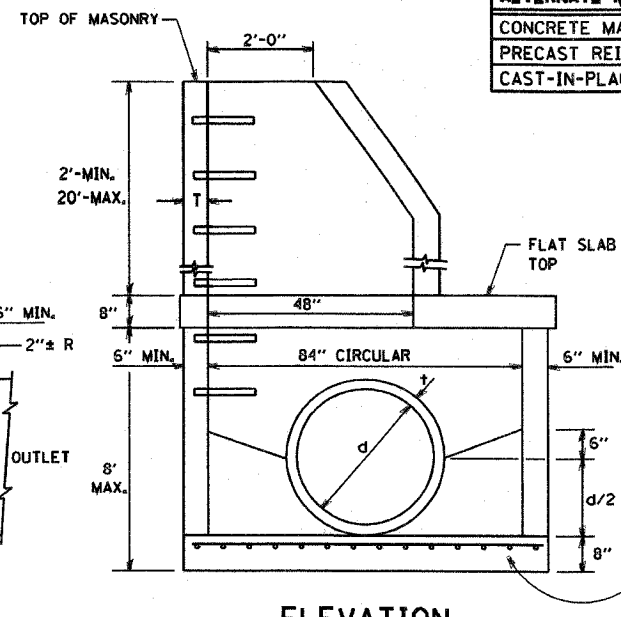

ELEVATION

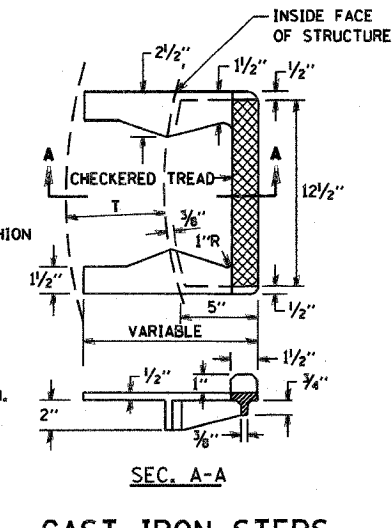
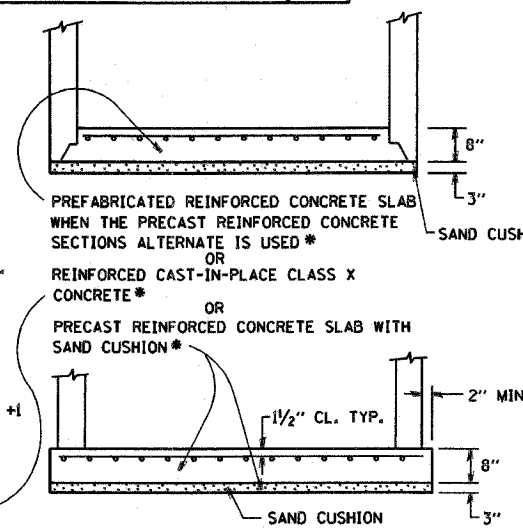

CAST IRON STEPS

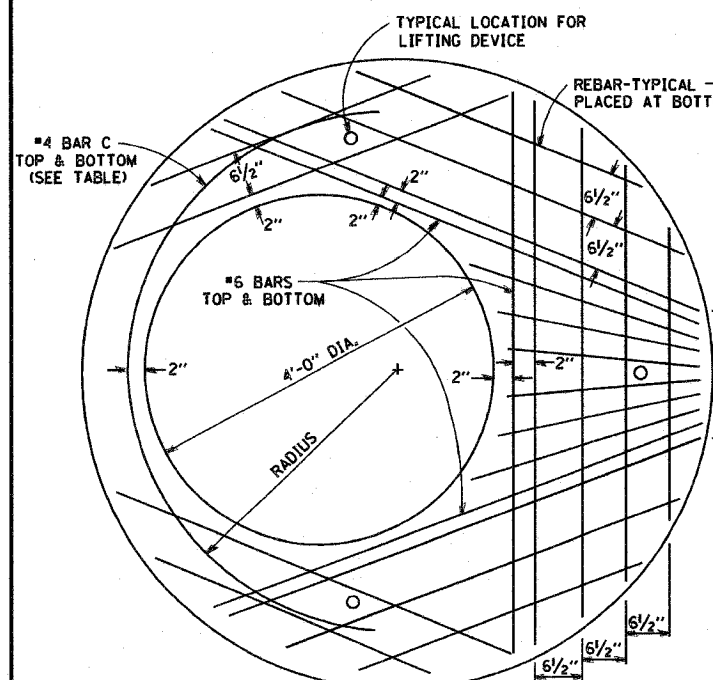

PLAN
SHOWING REBAR REINFORCEMENT

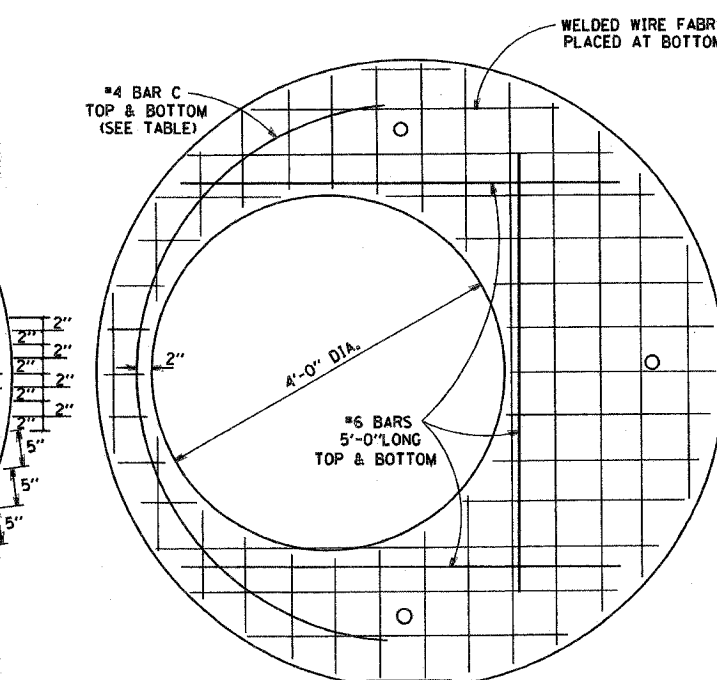
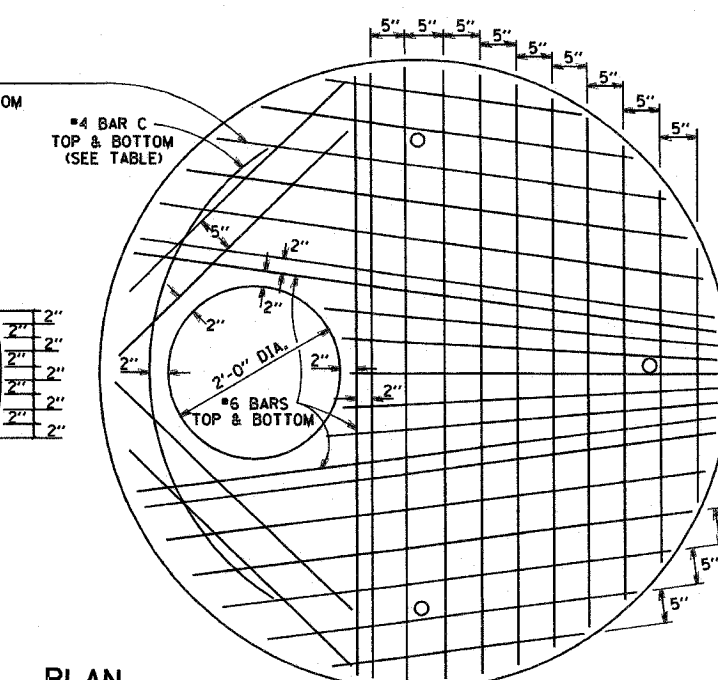

PLAN
SHOWING WELDED WIRE FABRIC REINFORCEMENT

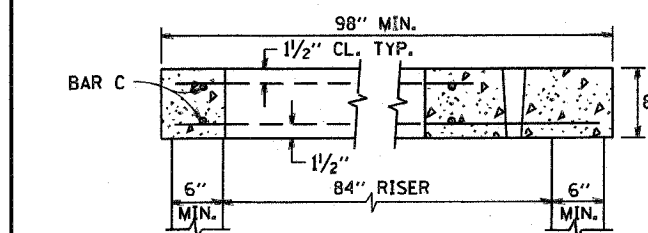

SECTION B-B

DIAMETER OF OPENING	REINFORCEMENT "A" 5' WWF OR BAR SIZE EACH DIRECTION	BAR C		
		SIZE	LENGTH	RADIUS
2'-0"	1.06 SQ.IN./LIN.FT.	#6	#4 6'-0"	38"
4'-0"	0.82 SQ.IN./LIN.FT.	#6	#4 9'-0"	38"

NOTE: THIS STRUCTURE SHOULD BE USED WITH PIPES SIZE 54" DIA. OR SMALLER.

REVISIONS		ILLINOIS DEPARTMENT OF TRANSPORTATION
NAME	DATE	
		<p align="center">MANHOLE TYPE A 7 FOOT DIAMETER</p> <p>SCALE: VERT. DRAWN BY HORIZ. CHECKED BY DATE: 1/18/2007 BD600-11 (BD-37)</p> <p align="right">REVISION DATE:</p>

PLOT DATE: 1/18/2007
 FILE NAME: K:\projects\62896\37.dwg
 PLOT SCALE: 1/8" = 1'-0"
 USER NAME: bboard

CONTRACT NO. 62876			
F.A. RTE.	SECTION	COUNTY	TOTAL SHEETS
55			227
STA.	TO STA.		
FED. ROAD DIST. NO.	ILLINOIS	FED. AID PROJECT	

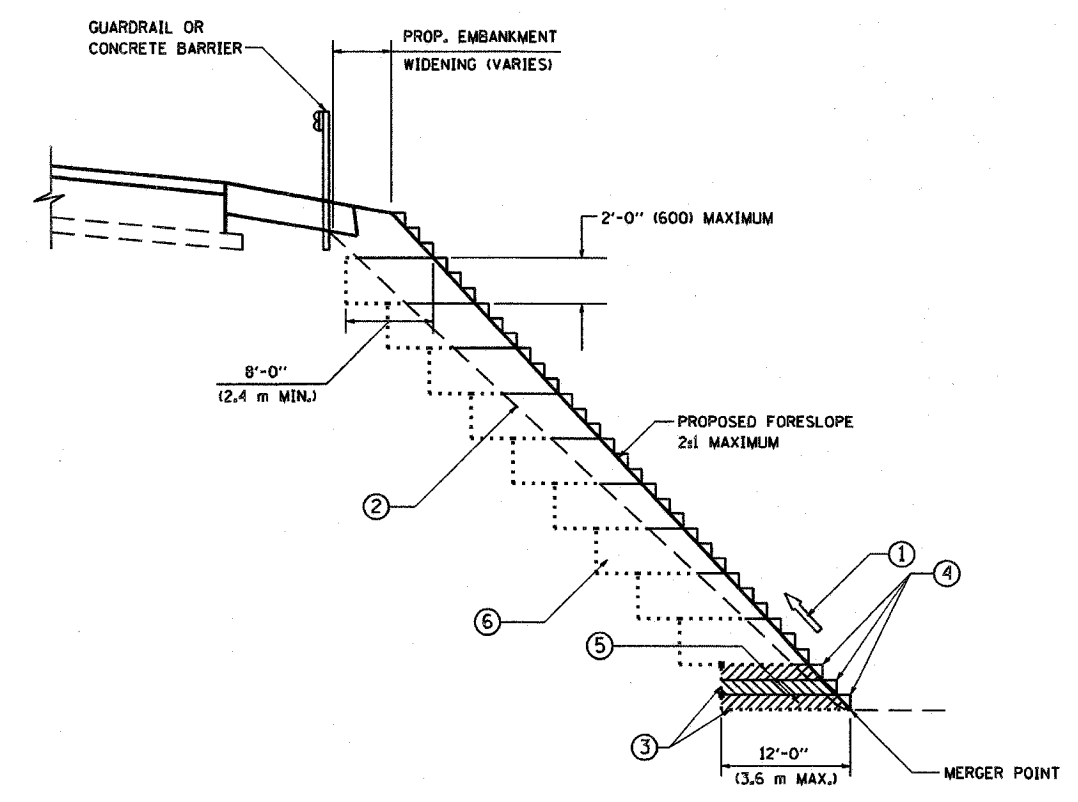

**TYPICAL BENCHING DETAIL
FOR EMBANKMENT**

NOTES:

- ① CONSTRUCT SUCCEEDING BENCH CUTS AND EMBANKMENT PLACEMENT AND COMPACTION FROM BOTTOM TO TOP IN STAIRSTEP FASHION.
- ② EXISTING FORESLOPE PREPARED IN ACCORDANCE WITH ARTICLE 205.03 OF THE STANDARD SPECIFICATIONS.
- ③ BENCH CUT EXISTING SLOPE TYPICAL FOR EACH STEP.
- ④ TRIM TO FINAL SLOPE.
- ⑤ EQUAL 8-INCH (200) LIFTS OF EMBANKMENT COMPACTED IN ACCORDANCE WITH ARTICLE 205.05 OF THE STANDARD SPECIFICATIONS.
- ⑥ EXCAVATION OF BENCH CUTS WITHIN EXISTING EMBANKMENT WILL BE PAID FOR AT THE CONTRACT UNIT PRICE PER CUBIC METER OR CUBIC YARD FOR "EARTH EXCAVATION". THIS PRICE WILL INCLUDE ALL LABOR AND MATERIAL, NO ADDITIONAL COMPENSATION WILL BE ALLOWED.
- ⑦ SLOPES SHALL BE BENCHED ACCORDING TO THIS DETAIL WHEN THE SLOPE IS STEEPER THAN 4:1 AND THE HEIGHT IS GREATER THAN 5' (1.5 m)

ALL DIMENSIONS ARE IN INCHES (MILLIMETERS) UNLESS OTHERWISE SHOWN.

REVISIONS	
NAME	DATE

ILLINOIS DEPARTMENT OF TRANSPORTATION

**BENCHING DETAIL
FOR EMBANKMENT
WIDENING**

SCALE: VERT. _____
HORIZ. _____
DATE: 1/18/2007

DRAWN BY: CADD
CHECKED BY: S.E.B.
BD-51
REVISION DATE: 01/01/07

PLOT DATE = 1/18/2007
FILE NAME = K:\databases\bd51.dgn
PLOT SCALE = 1/8" = 1'-0"
USER NAME = bward

F.A. RTE.	SECTION	COUNTY	TOTAL SHEETS	SHEET NO.
55			227	158
STA.		TO STA.		
FED. ROAD DIST. NO.		ILLINOIS FED. AID PROJECT		

SINGLE LANE WEAVE

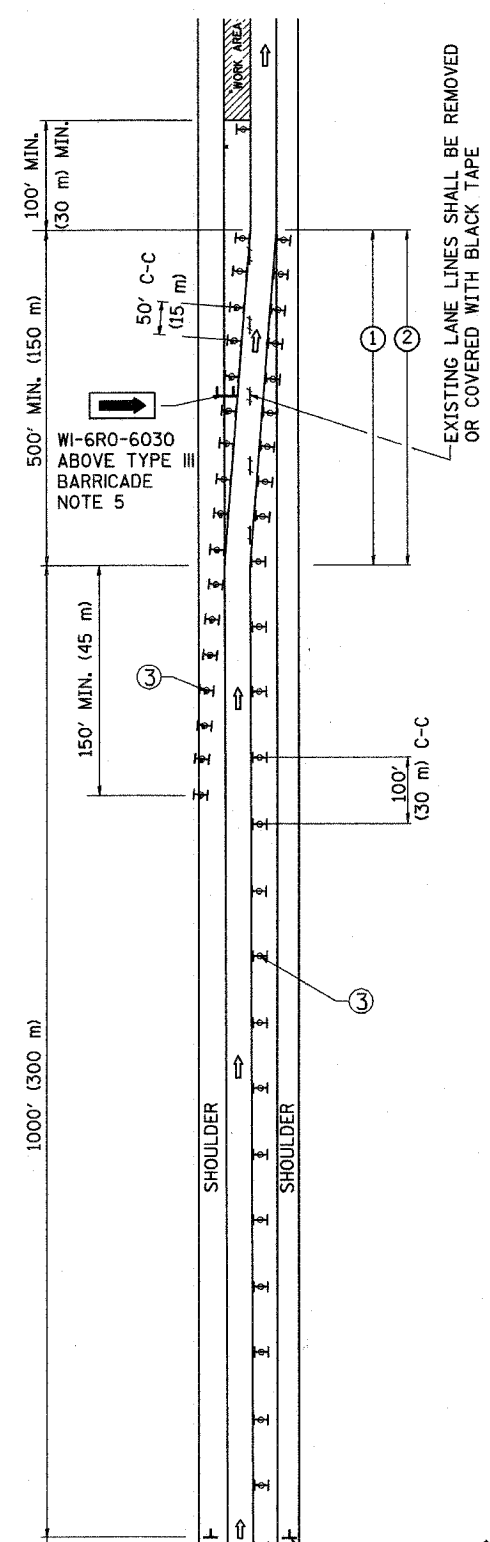

RIGHT LANE CLOSED SIGNING & BARRICADING ACCORDING TO FREEWAY STANDARD FOR A ONE LANE CLOSURE

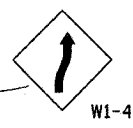

MULTI-LANE WEAVE

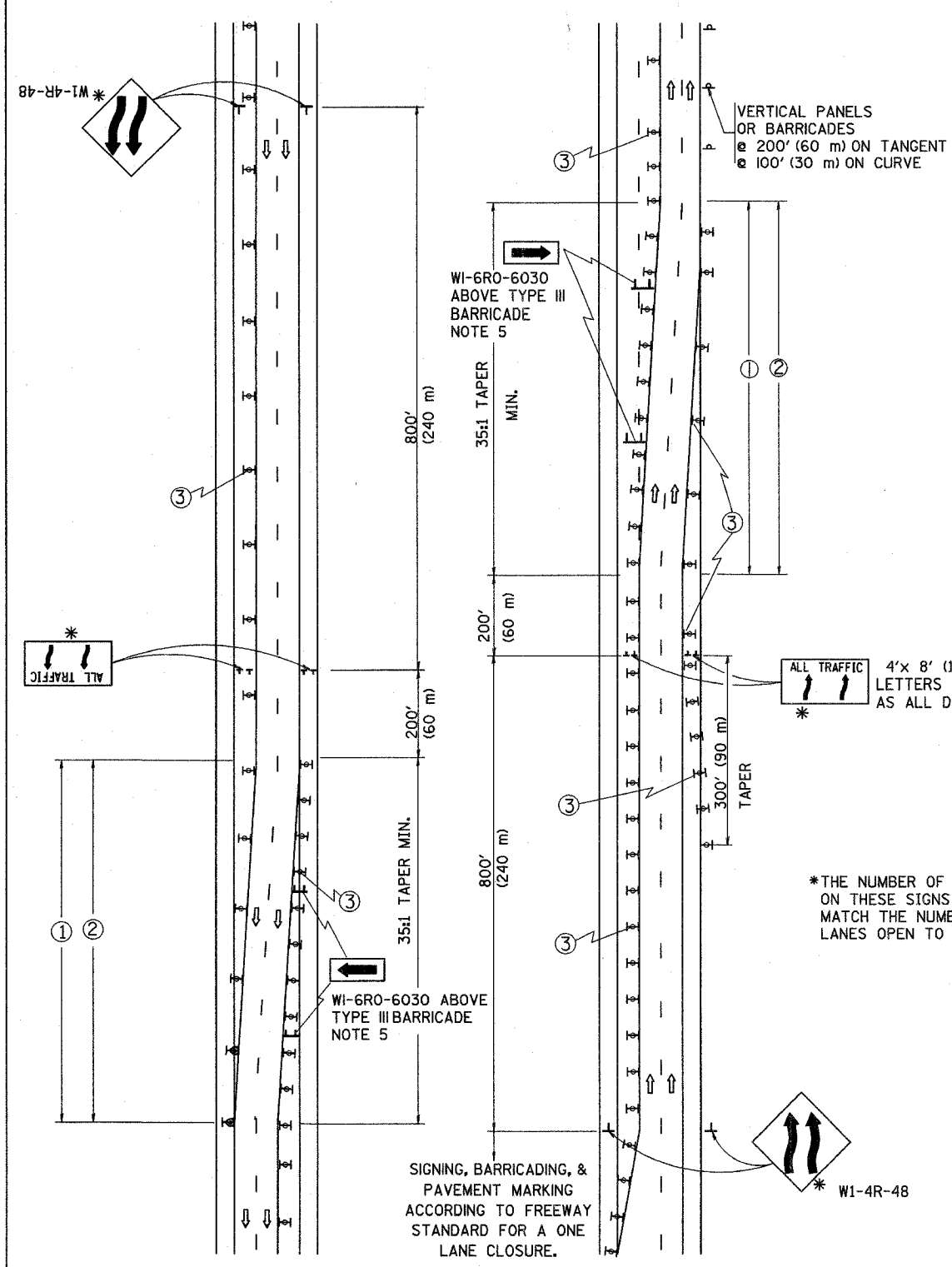

GENERAL NOTES

- EXISTING CONFLICTING PAVEMENT MARKING LINES SHALL BE REMOVED OR COVERED WITH BLACK TAPE. PAVEMENT MARKING REMOVAL OR BLACK TAPE SHALL NOT BE REQUIRED FOR LANE CLOSURES UNDER 24 HOURS IN DURATION.
- CONTINUOUS REFLECTIVE TEMPORARY PAVEMENT MARKING TAPE SHALL BE PLACED THROUGHOUT THE TAPER AND FOR 300' (90 m) ALONG SIDE THE WORK AREA WHERE THE CLOSURE TIME IS GREATER THAN FOURTEEN DAYS. THE LEFT EDGE LINE SHALL BE YELLOW AND THE RIGHT EDGE LINE SHALL BE WHITE. FOR MULTI-LANE WEAVE LANE LINES SHALL BE 10'-30' (3 m-9 m) SKIP DASH, WHITE.
- PLASTIC DRUMS WITH STEADY BURN LIGHTS AT 50' (15 m) C-C SPACING IN TAPERS AND 100' (30 m) C-C SPACING IN TANGENTS.
- ALL SIGNS SHALL BE POST MOUNTED IF THE CLOSURE TIME EXCEEDS FOUR DAYS.
- IF A TYPE III BARRICADE WITH AN ATTACHED SIGN PANEL WHICH MEETS NCHRP 350 IS NOT AVAILABLE, THE SIGNS MAY BE MOUNTED ON NCHRP 350 TEMPORARY SIGN SUPPORTS DIRECTLY IN FRONT OF THE BARRICADE.
- IF THE WIDTH OF OFFSET IS LESS THAN 6' THEN THE TYPE III BARRICADE WITH ATTACHED ARROW SIGN PANEL CAN BE ELIMINATED IN THE TAPER AREAS.

SYMBOLS

- DIRECTION OF TRAFFIC
- WORK AREA
- SIGN ON PORTABLE OR PERMANENT SUPPORT
- TYPE II BARRICADE, DRUM OR VERTICAL BARRICADE WITH MONO-DIRECTIONAL STEADY BURNING LIGHT

ALL DIMENSIONS ARE IN INCHES (MILLIMETERS) UNLESS OTHERWISE SHOWN

REVISIONS	
NAME	DATE
DWS	2/87
DWS	1/90
DWS	12/27/94
DWS	11/96
JAF	4/03
JAF	2/06
SPB	1/07

ILLINOIS DEPARTMENT OF TRANSPORTATION
 TRAFFIC CONTROL DETAILS
 FOR FREEWAY
 SINGLE & MULTI-LANE WEAVE

SCALE: DATE: 1/4/2007

DRAWN BY: R.H.
 CHECKED BY: TC-9

PLOT DATE = 1/4/2007
 FILE NAME = c:\p\proj\m\datatst\ug90.dgn
 PLOT SCALE = 0.8000 / IN.
 USER NAME = luser01

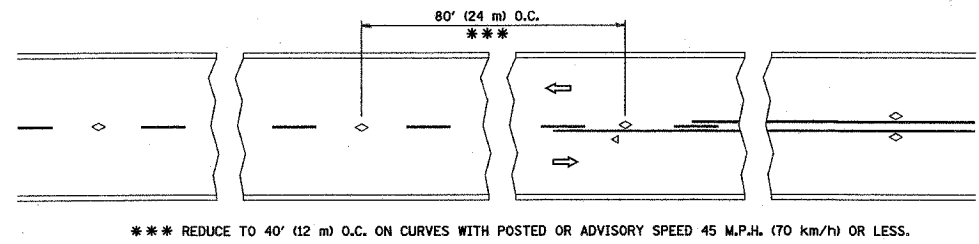

TWO-LANE/TWO-WAY

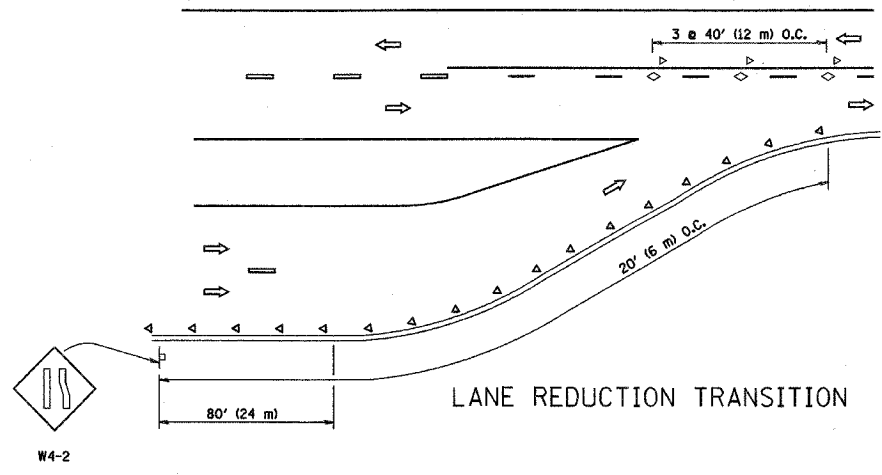

LANE REDUCTION TRANSITION

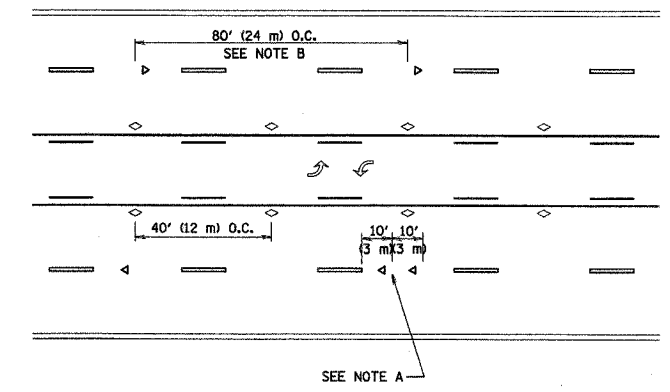

TWO-WAY LEFT TURN

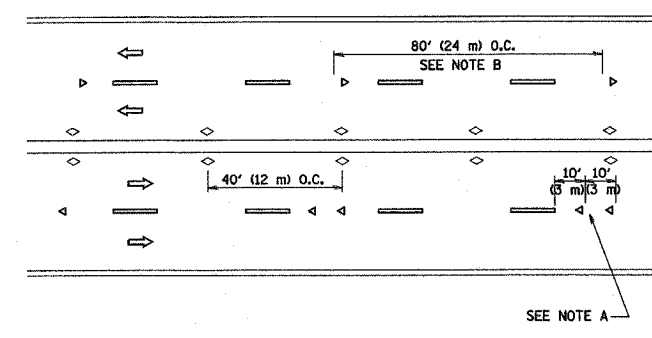

MULTI-LANE/UNDIVIDED

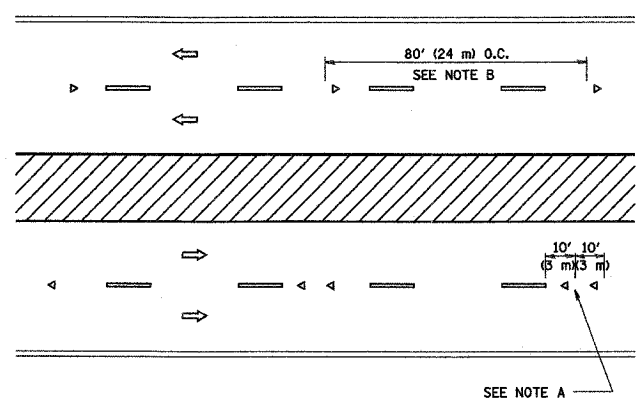

MULTI-LANE/DIVIDED

GENERAL NOTES

1. MARKERS USED WITH DASHED LINES SHALL BE CENTERED IN THE GAP BETWEEN SEGMENTS.
2. MARKERS USED ADJACENT TO SOLID LINES SHALL BE OFFSET 2 TO 3 (50 TO 75) TOWARD TRAFFIC AS SHOWN.
3. MARKERS THROUGH TANGENTS LESS THAN 500' (150 m) IN LENGTH BETWEEN CURVES SHALL BE INSTALLED AT THE LESSER OF THE TWO CURVE SPACINGS.

SYMBOLS

- YELLOW STRIPE
- WHITE STRIPE
- ◁ ONE-WAY AMBER MARKER
- ◁ ONE-WAY CRYSTAL MARKER (W/O)
- ◇ TWO-WAY AMBER MARKER

LANE MARKER NOTES

- B. REDUCE TO 40' (12 m) O.C. ON CURVES WHERE ADVISORY SPEEDS ARE 10 M.P.H. (20 km/h) LOWER THAN POSTED SPEEDS.
- A. USE DOUBLE LANE LINE MARKERS SPACED AS SHOWN.

DESIGN NOTES

1. DOUBLE LANE LINE MARKERS SHALL BE USED UNLESS SPECIFIED OTHERWISE.
2. EXCEPT AS SHOWN ON THE LANE REDUCTION TRANSITION AND FREEWAY EXIT RAMP DETAIL, MARKERS ARE NOT TO BE SPECIFIED ON RIGHT EDGE LINES.
3. THE EXACT MARKER LIMITS, SPACING, AND COLOR SHOULD BE INCLUDED IN THE PLANS.
4. MARKERS SHOULD NOT BE USED ALONGSIDE CURBS EXCEPT FOR EXTREMELY SHORT SECTIONS OF CURBS WHERE NOT MORE THAN TWO MARKERS WOULD BE INVOLVED.

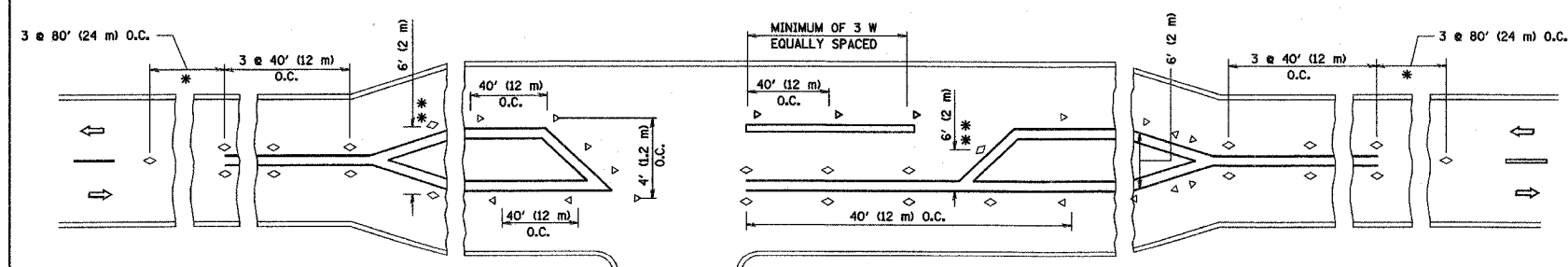

LEFT TURN

* SEE TWO-LANE/TWO-WAY WHERE MARKERS CONTINUE
 ** WHERE THE MEDIAN WIDTH IS 6' (2 m) OR LESS USE TWO-WAY MARKERS.

All dimensions are in millimeters (inches) unless otherwise shown.

REVISIONS	
NAME	DATE
T. RAMMACHER	09-19-94
T. RAMMACHER	03-12-99
T. RAMMACHER	01-06-00

ILLINOIS DEPARTMENT OF TRANSPORTATION
 TYPICAL APPLICATIONS
 RAISED REFLECTIVE PAVEMENT
 MARKERS (SNOW-PLOW RESISTANT)

SCALE: NONE
 DATE: 1/17/2007

DRAWN BY CADD
 CHECKED BY
 TC-11

REVISION DATE: 01/06/00

PLOT DATE = 1/17/2007
 FILE NAME = C:\Users\vaullidgn\Documents\111111.dgn
 USER NAME = vaullidgn

CONTRACT NO. 62896				
F.A. RTE. 55	SECTION	COUNTY	TOTAL SHEETS 227	SHEET NO. 160
STA.		TO STA.		
FED. ROAD DIST. NO.		ILLINOIS FED. AID PROJECT		

THE DIAGONAL LINES SHALL BE SPACED AT 40' (12 m) C-C ACROSS ALL STRUCTURES WHICH ARE 500' (150 m) OR LESS IN LENGTH
 THE DIAGONAL LINES ARE NOT REQUIRED ON SHOULDERS WHICH ARE 6' (1.8 m) OR LESS IN WIDTH

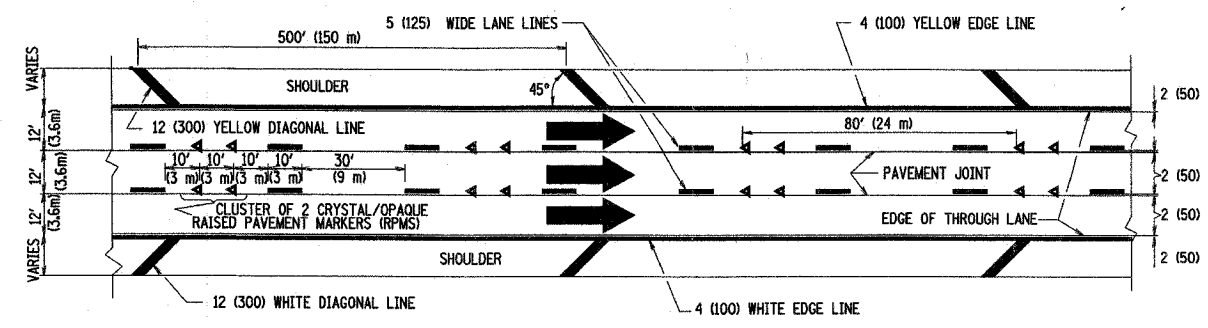

TYPICAL EDGE LINES & LANE LINES

- NOTES:
1. THERMO PLASTIC PAVEMENT MARKING LINE SHALL BE USED FOR THE EDGE LINES, GORE LINES, AND DIAGONAL LINES ON BITUMINOUS PAVEMENT ONLY.
 2. PREFORMED PLASTIC TYPE B PAVEMENT MARKING LINE SHALL BE USED FOR ALL LANE LINES ON BITUMINOUS PAVEMENT
 3. POLYUREA PAVEMENT MARKING SHALL BE USED FOR ALL MARKINGS ON PCC

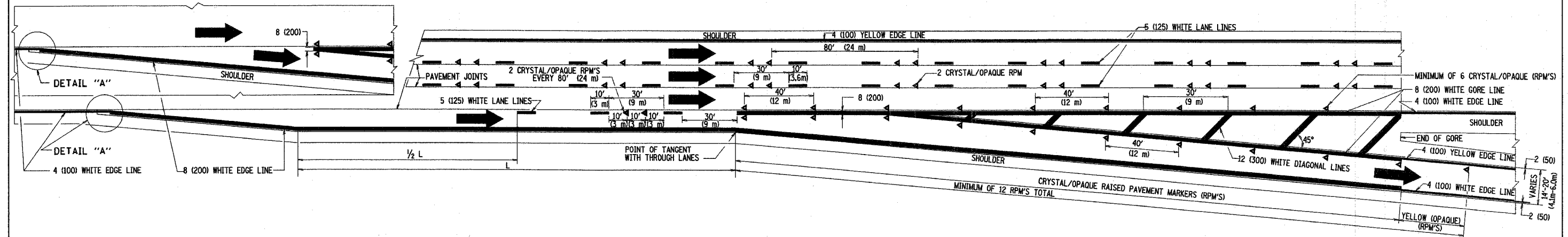
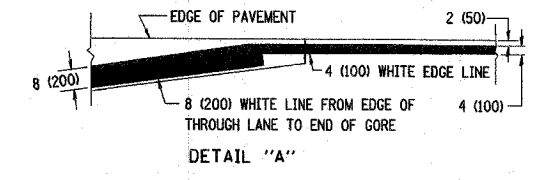

TYPICAL EXIT RAMP PAVEMENT MARKINGS

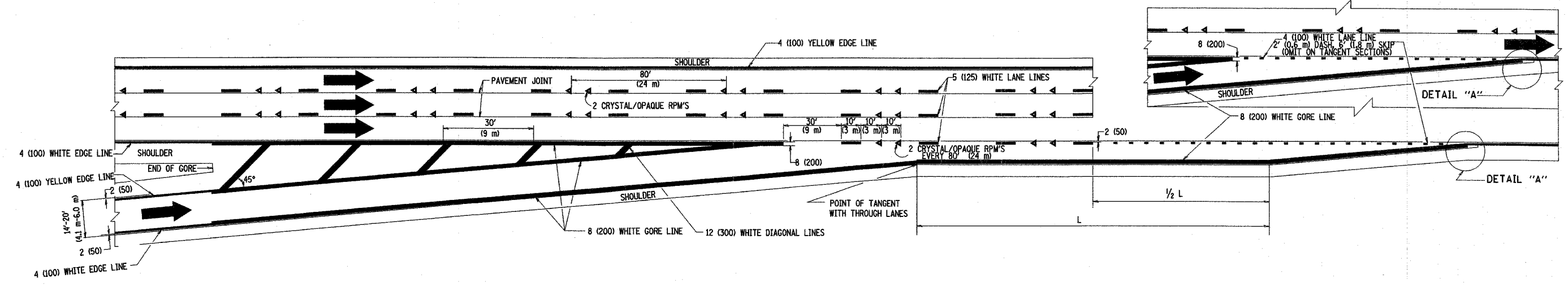

TYPICAL ENTRANCE RAMP PAVEMENT MARKINGS

REVISIONS	
NAME	DATE
DWS	1/90
DWS	5/91
AH	3/96
DWS	7/96
JAF	2/06
SPB	1/07

ILLINOIS DEPARTMENT OF TRANSPORTATION
 MULTI-LANE FREEWAY PAVEMENT MARKING DETAILS
 SCALE: NONE
 DATE: 1/4/2007
 DRAWN BY C.A.D.D.
 CHECKED BY
 TC12 SHEET 1 OF 2
 REVISION DATE: 01/01/07

PLOT DATE = 1/4/2007
 FILE NAME = c:\p\proj\mca\data\std\std2.dgn
 PLOT SCALE = 50.0000 / IN.
 USER NAME = jasonr

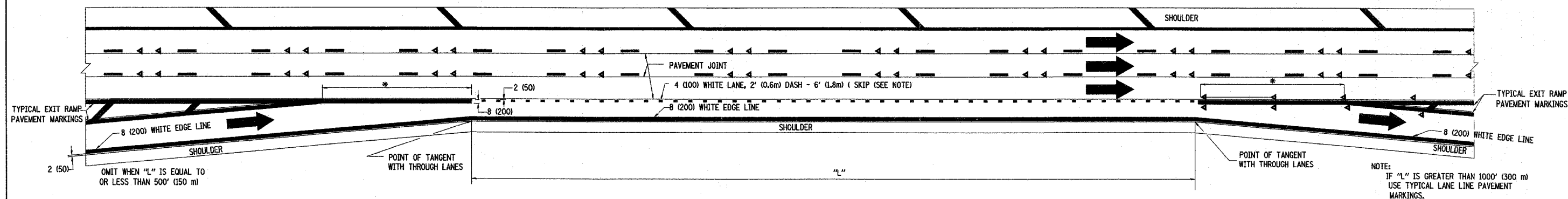

TYPICAL ENTRANCE/EXIT RAMP COMBINATION PAVEMENT MARKINGS

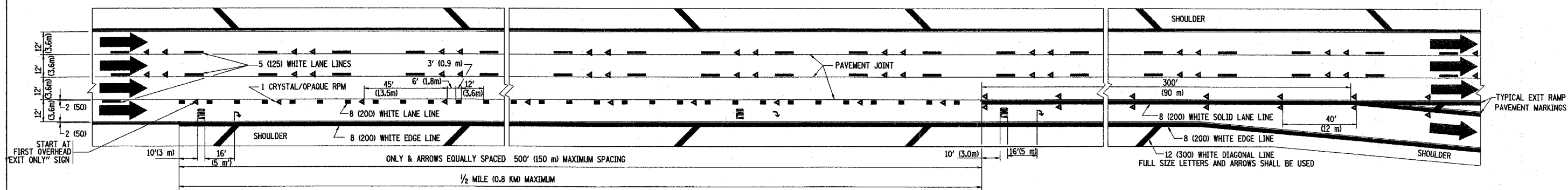

TYPICAL EXIT ONLY LANE PAVEMENT MARKINGS

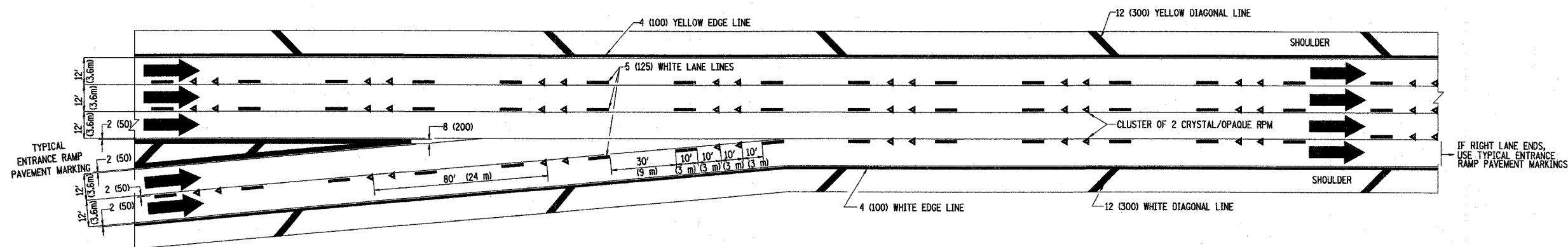

TYPICAL TWO LANE ENTRANCE RAMP PAVEMENT MARKINGS

REVISIONS	
NAME	DATE
DWS	1/90
DWS	5/91
SPB	1/07

ILLINOIS DEPARTMENT OF TRANSPORTATION
**MULTI-LANE FREEWAY
 PAVEMENT MARKING
 DETAILS**

SCALE: NONE
 DATE: 1/16/2007

DRAWN BY C.A.D.D.
 CHECKED BY

PLOT DATE = 1/16/2007
 FILE NAME = K:\databases\12.dgn
 PLOT SCALE = 1/8" = 1'-0"
 USER NAME = leggs

F.A. RTE.	SECTION	COUNTY	TOTAL SHEETS	SHEET NO.
65			227	162
STA.	TO STA.			
FED. ROAD DIST. NO.	ILLINOIS	FED. AID PROJECT		

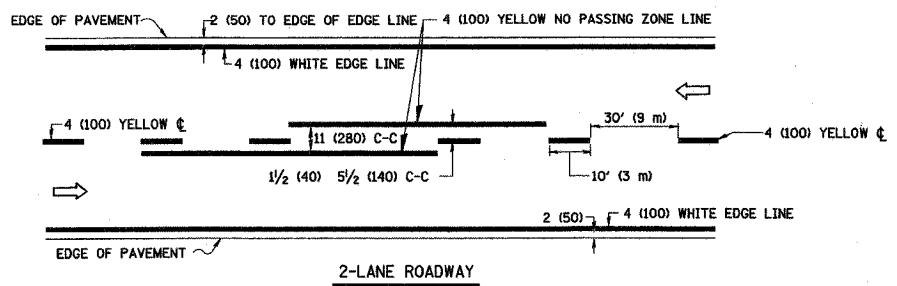

2-LANE ROADWAY

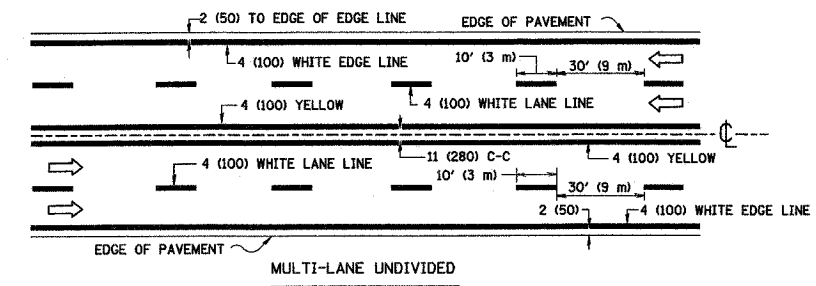

MULTI-LANE UNDIVIDED

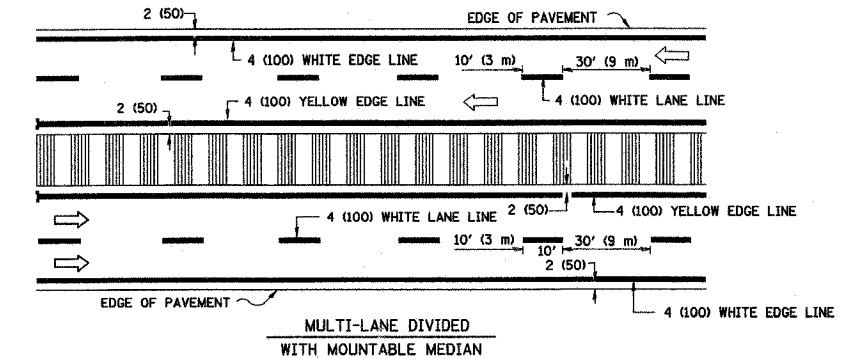

MULTI-LANE DIVIDED WITH MOUNTABLE MEDIAN

NOTE: MEDIANS WITH BARRIER CURB DO NOT REQUIRE AN EDGE LINE

TYPICAL LANE AND EDGE LINE MARKING

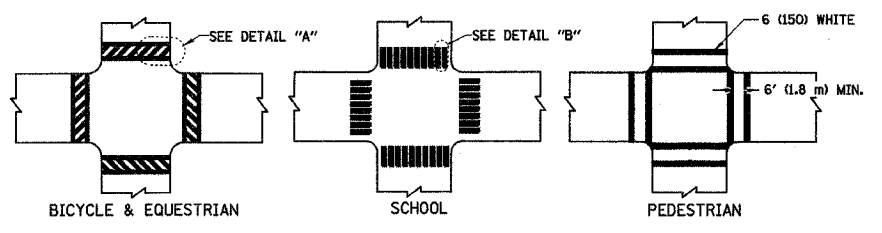

TYPICAL CROSSWALK MARKING

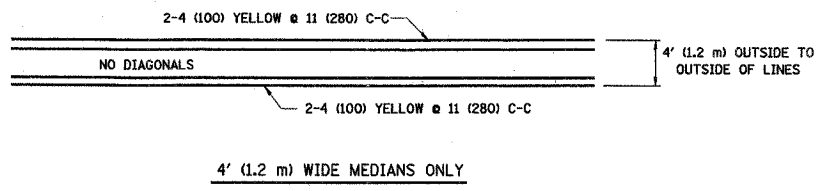

4' (1.2 m) WIDE MEDIANS ONLY

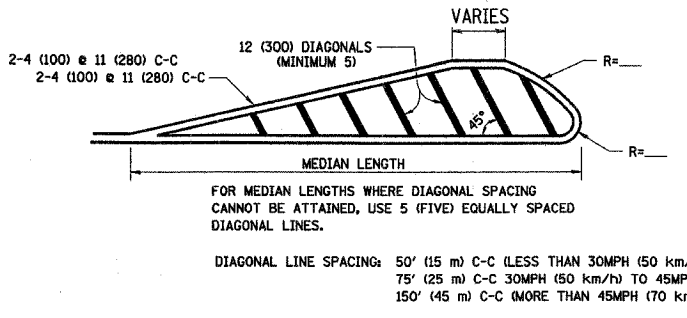

MEDIANS OVER 4' (1.2 m) WIDE

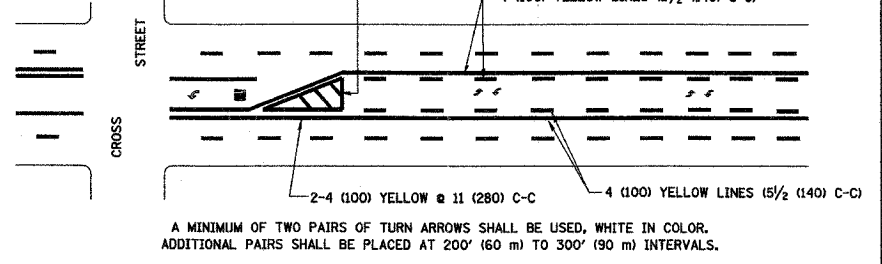

TYPICAL PAINTED MEDIAN MARKING

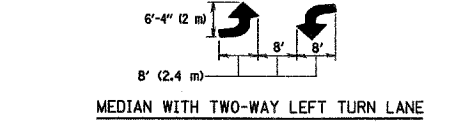

TYPICAL TURN LANE MARKING

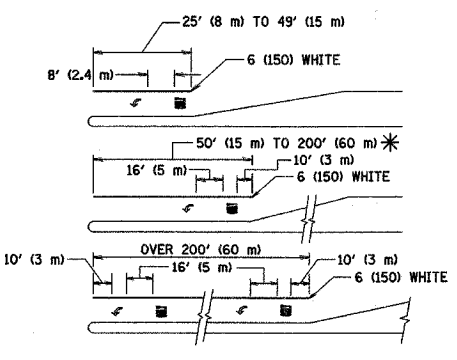

FULL SIZE LETTERS 8' (2.4 m) AND ARROWS SHALL BE USED. AREA = 15.6 SQ. FT. (1.5 m²) ONLY AREA = 20.8 SQ. FT. (1.9 m²)

* TURN LANES IN EXCESS OF 400' (120 m) IN LENGTH MAY HAVE AN ADDITIONAL SET OF ARROW - "ONLY" INSTALLED MIDWAY BETWEEN THE OTHER TWO SETS OF ARROW - "ONLY".

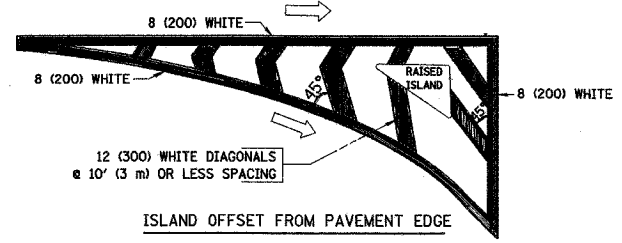

ISLAND OFFSET FROM PAVEMENT EDGE

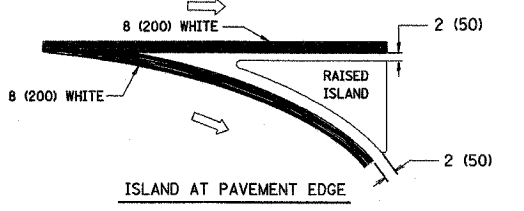

ISLAND AT PAVEMENT EDGE

TYPICAL ISLAND MARKING

TYPE OF MARKING	WIDTH OF LINE	PATTERN	COLOR	SPACING / REMARKS
CENTERLINE ON 2 LANE PAVEMENT	4 (100)	SKIP-DASH	YELLOW	10' (3 m) LINE WITH 30' (9 m) SPACE
CENTERLINE ON MULTI-LANE UNDIVIDED PAVEMENT	2 @ 4 (100)	SOLID	YELLOW	11 (280) C-C
NO PASSING ZONE LINES: FOR ONE DIRECTION FOR BOTH DIRECTIONS	4 (100) 2 @ 4 (100)	SOLID SOLID	YELLOW YELLOW	5/2 (140) C-C FROM SKIP-DASH CENTERLINE 11 (280) C-C OMIT SKIP-DASH CENTERLINE BETWEEN
LANE LINES	4 (100) 5 (125) ON FREEWAYS	SKIP-DASH SKIP-DASH	WHITE WHITE	10' (3 m) LINE WITH 30' (9 m) SPACE
DOTTED LINES (EXTENSIONS OF CENTER, LANE OR TURN LANE MARKINGS)	SAME AS LINE BEING EXTENDED	SKIP-DASH	SAME AS LINE BEING EXTENDED	2' (600) LINE WITH 6' (1.8 m) SPACE
EDGE LINES	4 (100)	SOLID	YELLOW-LEFT WHITE-RIGHT	OUTLINE MOUNTABLE MEDIANS IN YELLOW; EDGE LINES ARE NOT USED NEXT TO BARRIER CURB
TURN LANE MARKINGS	6 (150) LINE; FULL SIZE LETTERS & SYMBOLS (8' (2.4m))	SOLID	WHITE	SEE TYPICAL TURN LANE MARKING DETAIL
TWO WAY LEFT TURN MARKING	2 @ 4 (100) EACH DIRECTION 8' (2.4m) LEFT ARROW	SKIP-DASH AND SOLID IN PAIRS	YELLOW WHITE	10' (3 m) LINE WITH 30' (9 m) SPACE FOR SKIP-DASH; 5/2 (140) C-C BETWEEN SOLID LINE AND SKIP-DASH LINE SEE TYPICAL TWO-WAY LEFT TURN MARKING DETAIL
CROSSWALK LINES (PEDESTRIAN) A. DIAGONALS (BIKE & EQUESTRIAN) B. LONGITUDINAL BARS (SCHOOL)	2 @ 6 (150) 12 (300) @ 45° 12 (300) @ 90°	SOLID SOLID SOLID	WHITE WHITE WHITE	NOT LESS THAN 6' (1.8 m) APART 2' (600) APART 2' (600) APART SEE TYPICAL CROSSWALK MARKING DETAILS.
STOP LINES	24 (600)	SOLID	WHITE	PLACE 4' (1.2 m) IN ADVANCE OF AND PARALLEL TO CROSSWALK, IF PRESENT. OTHERWISE, PLACE AT DESIRED STOPPING POINT, PARALLEL TO CROSSROAD CENTERLINE, WHERE POSSIBLE
PAINTED MEDIANS	2 @ 4 (100) WITH 12 (300) DIAGONALS @ 45° NO DIAGONALS USED FOR 4' (1.2 m) WIDE MEDIANS	SOLID	YELLOW; TWO WAY TRAFFIC WHITE; ONE WAY TRAFFIC	11 (280) C-C FOR THE DOUBLE LINE SEE TYPICAL PAINTED MEDIAN MARKING.
GORE MARKING AND CHANNELIZING LINES	8 (200) WITH 12 (300) DIAGONALS @ 45°	SOLID	WHITE	DIAGONALS: 15' (4.5 m) C-C (LESS THAN 30MPH (50 km/h)) 20' (6 m) C-C 30MPH (50 km/h) TO 45MPH (70 km/h) 30' (9 m) C-C (OVER 45MPH (70 km/h))
RAILROAD CROSSING	24 (600) TRANSVERSE LINES; "RR" IS 6' (1.8 m) LETTERS; 16 (400) LINE FOR "X"	SOLID	WHITE	SEE STATE STANDARD 780001 AREA OF: "R"=3.6 SQ. FT. (0.33 m ²) EACH "X"=54.0 SQ. FT. (5.0 m ²)
SHOULDER DIAGONALS	12 (300) @ 45°	SOLID	WHITE - RIGHT YELLOW - LEFT	50' (15 m) C-C (LESS THAN 30MPH (50 km/h)) 75' (25 m) C-C (30 MPH (50 km/h) TO 45MPH (70 km/h)) 150' (45 m) C-C (OVER 45MPH (70 km/h))

FOR FURTHER DETAILS ON PAVEMENT MARKING REFER TO STANDARD SPECIFICATIONS FOR ROAD AND BRIDGE CONSTRUCTION AND STATE STANDARD 780001.

All dimensions are in millimeters (inches) unless otherwise shown.

REVISIONS	
NAME	DATE
EVERS	03-19-90
T. RAMMACHER	10-27-94
ALEX HOUSEH	10-09-96
T. RAMMACHER	01-06-00

ILLINOIS DEPARTMENT OF TRANSPORTATION
DISTRICT ONE
TYPICAL PAVEMENT MARKINGS

SCALE: NONE
DATE: 1/17/2007
DRAWN BY CADD
CHECKED BY
TC-13
REVISION DATE: 01/06/00

DATE: 1/17/2007
FILE NAME: K:\dms\m\vol3\design
USER: JMS

PARTIAL RAMP CLOSURE DETAILS

SHOULDER CLOSURE DETAILS

F.A. RTE.	SECTION	COUNTY	TOTAL SHEETS	SHEET NO.
55			227	163
STA. TO STA.		ILLINOIS FED. AID PROJECT		

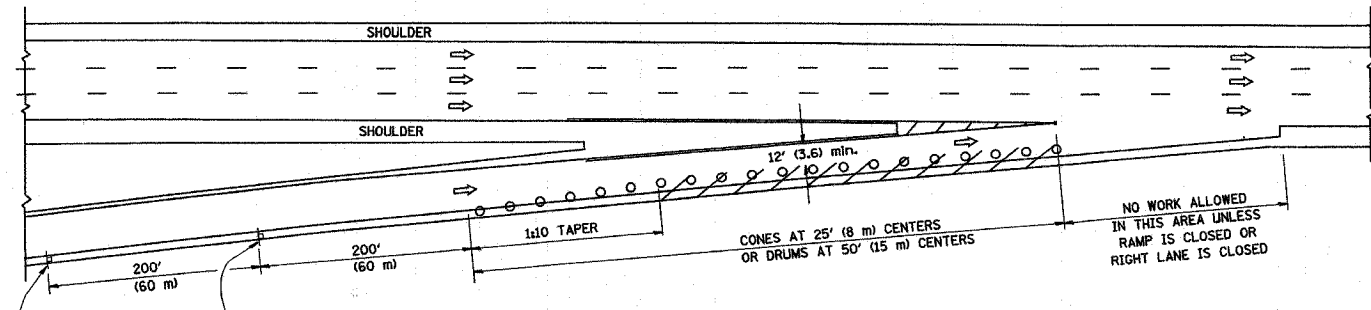

TYPICAL ENTRANCE RAMP

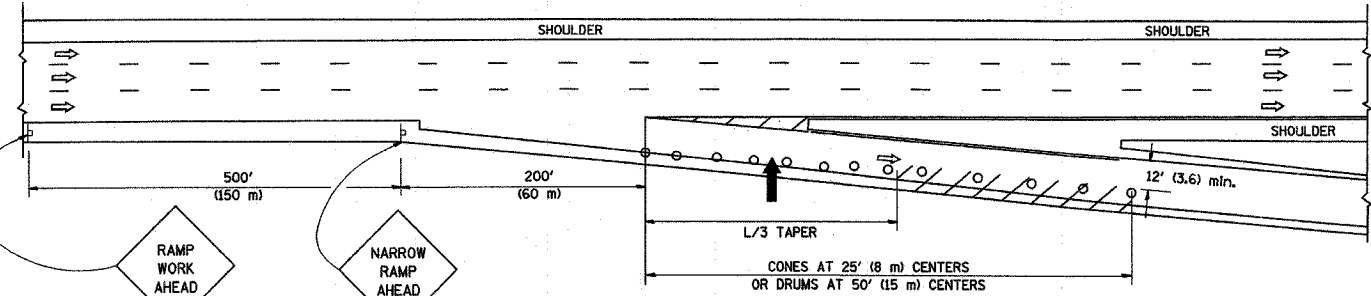

TYPICAL EXIT RAMP

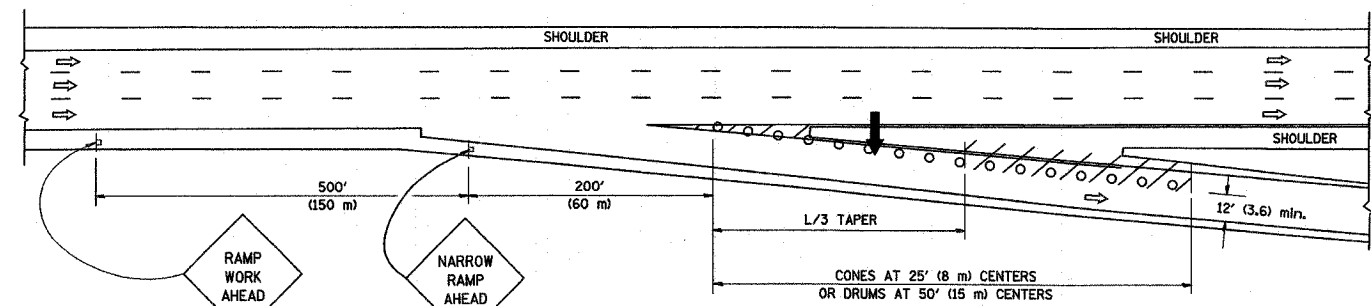

TYPICAL EXIT RAMP

SYMBOLS

- ➔ ARROWBOARD
- ▨ WORK AREA
- ⊥ SIGN ON PORTABLE OR PERMANENT SUPPORT
- FLAGGER WITH CONTROL SIGN
- ⊥ TYPE II BARRICADE, DRUM OR VERTICAL BARRICADE WITH STEADY BURN MONO-DIRECTIONAL LIGHT
- CONE, DRUM OR BARRICADE

GENERAL NOTES

- THE "L" DISTANCE EQUALS:

SPEED LIMIT	FORMULAS
45 mph (80 km/h) OR GREATER	METRIC ENGLISH $L=0.65(W/S)$ $L=(W/S)$
W = WIDTH OF OFFSET IN FEET (METERS)	
S = NORMAL POSTED SPEED MPH (KM/H)	
- PLASTIC DRUMS WITH HIGH PERFORMANCE REFLECTIVE SHEETING AND STEADY BURNING LIGHTS ARE REQUIRED FOR ALL NIGHTTIME CLOSURES.
- ALL SIGNS SHALL BE POST MOUNTED IF THE CLOSURE TIME EXCEEDS FOUR DAYS.
- FLASHING LIGHTS SHALL BE USED DURING THE HOURS OF DARKNESS AND SHALL BE INSTALLED ABOVE THE FIRST TWO SETS OF SIGNS.

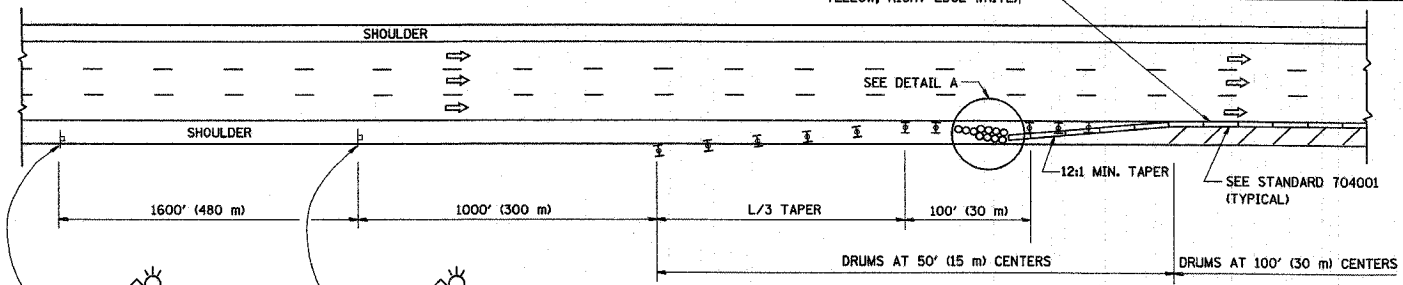

PERMANENT SHOULDER CLOSURE

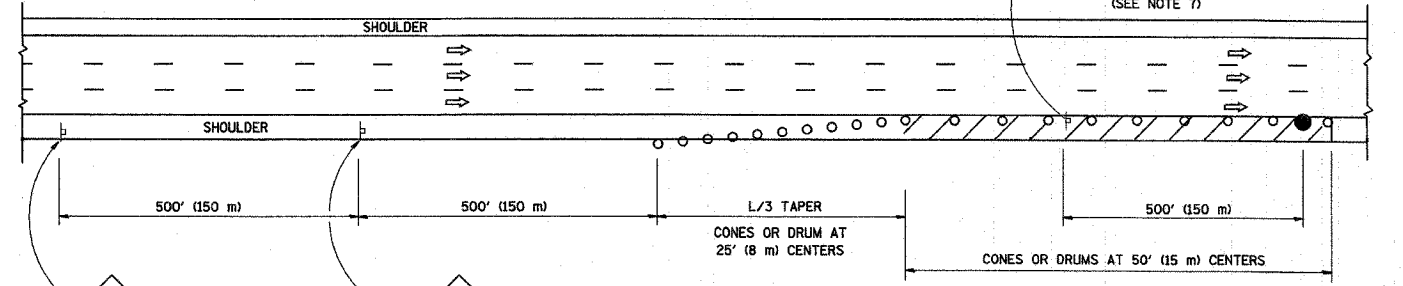

DAYTIME SHOULDER CLOSURE

OR WHEN SPECIFIED INSTALL TEMPORARY CONCRETE BARRIER WALL WITH BARRIER WALL REFLECTORS PER TRAFFIC CONTROL AND PROTECTION (EXPRESSWAYS)

THIS DETAIL IS USED WHERE:
1. VEHICLES, EQUIPMENT, WORKERS OR THEIR ACTIVITIES ENCR OACH IN AN AREA CLOSER THAN 15' (4.5 m) TO THE EDGE OF PAVEMENT FOR A PERIOD IN EXCESS OF 15 MINUTES.

ARRAY DESIGN PER MANUFACTURER TO BE NCHRP 350 COMPLIANT FOR POSTED SPEED.

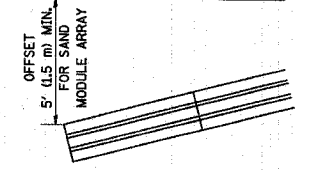

DETAIL "A"
IMPACT ATTENUATOR, TEMPORARY
(SEE NOTE 5)

- THE IMPACT ATTENUATOR, TEMPORARY IS NOT REQUIRED WHEN THE TEMPORARY CONCRETE BARRIER WALL IS PROTECTED BY OR IS TIED INTO THE EXISTING GUARDRAIL. IF OFFSET IS LESS THAN 5 FEET USE "TRAFFIC BARRIER TERMINAL, TYPE III, TEMPORARY" DEVICE TO MEET NCHRP350 FOR POSTED SPEED.
- AUTHORIZATION FROM THE DISTRICT'S BUREAU OF TRAFFIC IS REQUIRED FOR ALL FREEWAY CLOSURES.
- THE FLAGGER AND FLAGGER SIGN ARE REQUIRED AT THE ABOVE WORK SITES WHEN:
 - FOUR OR MORE WORK VEHICLES ENTER THE TRAFFIC LANES IN A ONE HOUR PERIOD.
 - THE WORK AVTIVITY REQUIRES FREQUENT ENCR OACHMENT INTO THE LANE OPEN TO TRAFFIC.
 THE FLAGGER SHALL BE STATIONED APPROXIMATELY 100' (30 m) TO 200' (60 m) IN ADVANCE OF THE WORKERS.

ALL DIMENSIONS ARE IN INCHES (MILLIMETERS) UNLESS OTHERWISE SHOWN.

REVISIONS	
NAME	DATE
DWS	11/96
JAF	12/02
NCHRP 350	04/03
JAF	2/06
SPB	1/07

ILLINOIS DEPARTMENT OF TRANSPORTATION
TRAFFIC CONTROL DETAILS
FOR FREEWAY
SHOULDER CLOSURES
PARTIAL RAMP CLOSURES

DESIGNED BY: DWS
DRAWN BY:
CHECKED BY:

SCALE: NONE
DATE: 1/16/2007
TC-17

PLOT DATE = 1/16/2007
 FILE NAME = K:\ansatz\7-07.dgn
 PLOT SCALE = 50.0000 / 1
 USER NAME = jafjan

F.A. RTE.	SECTION	COUNTY	TOTAL SHEETS	SHEET NO.
55	99 (1&2) WRS-1	WILL.	227	164A
FED. ROAD DIST. NO.		ILLINOIS	FED. AID PROJECT	

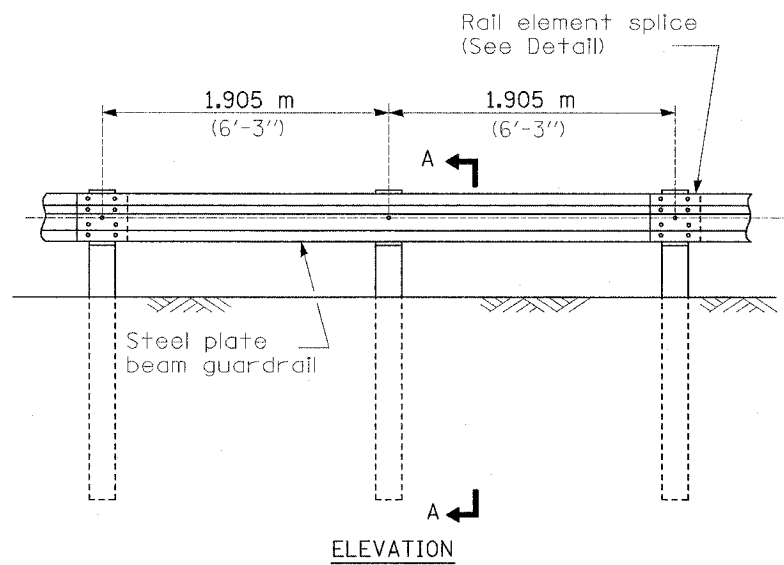

TYPE A

1.905 m (6'-3") Typical post spacing

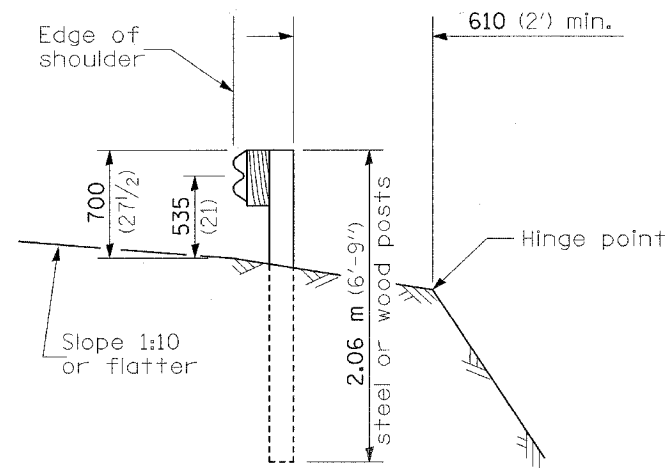

SECTION A-A

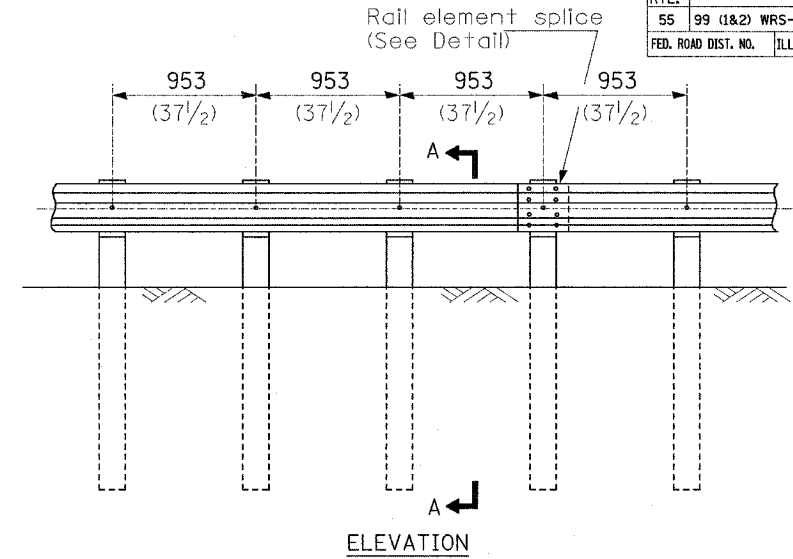

TYPE B

953 (37 1/2) Closed post spacing

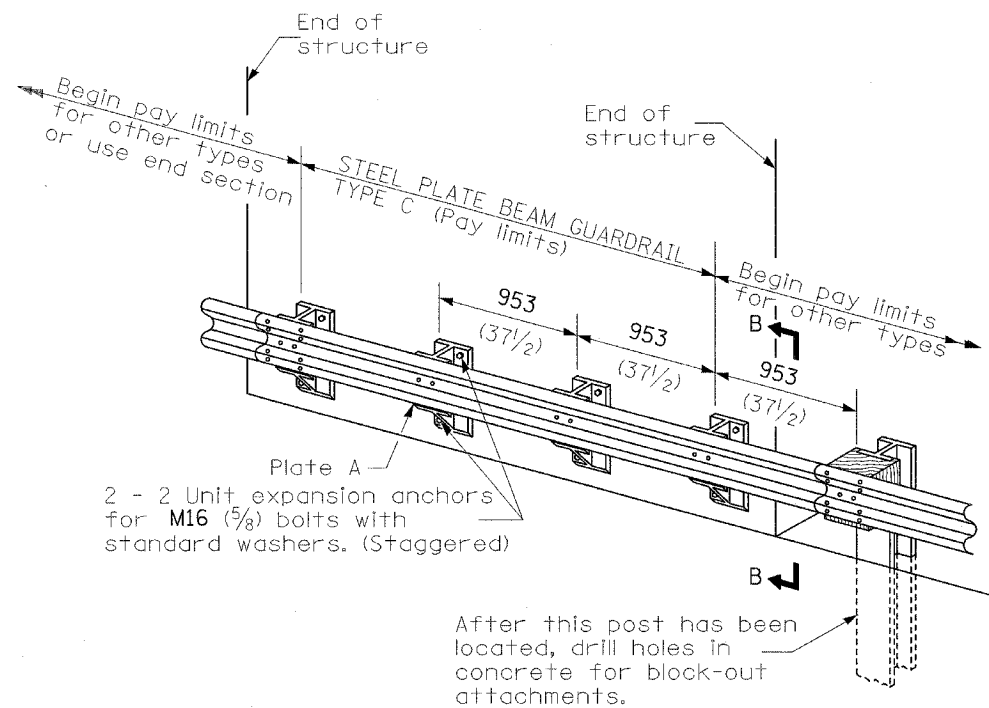

TYPE C

953 (37 1/2) Block-out spacing

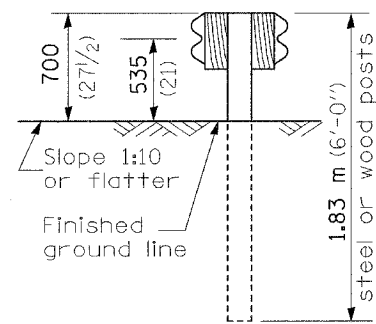

SECTION C-C

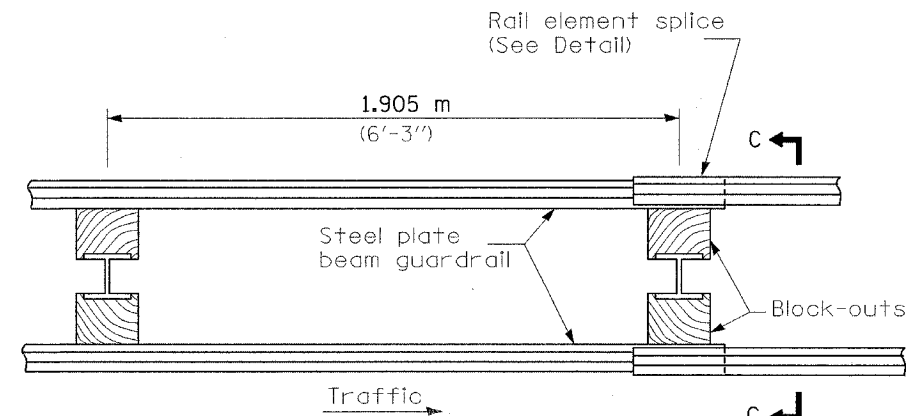

TYPE D

Double steel plate beam guardrail
1.905 m (6'-3") typical post spacing

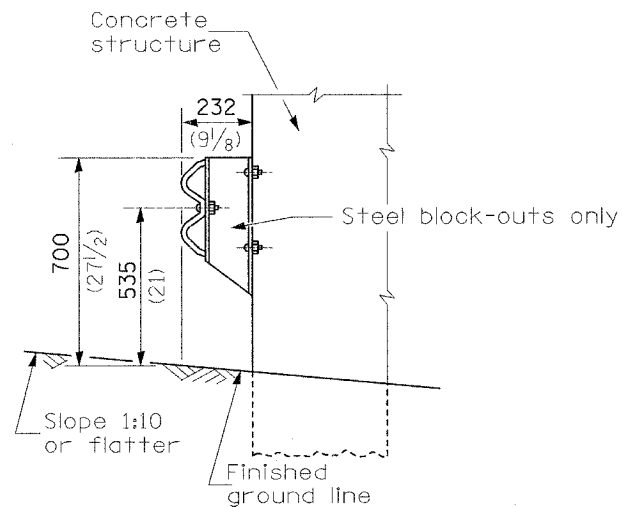

SECTION B-B

GENERAL NOTES

All slope ratios are expressed as units of vertical displacement to units of horizontal displacement (V:H).

All dimensions are in millimeters (inches) unless otherwise shown.

The existing steel posts may be drilled to match the bolt pattern shown herein for the wood block-out, or a new steel post shall be provided.

This detail is applicable to the guardrail system used prior to January 1, 2007. For details on the Midwest Guardrail System, see Standard 630001.

**REMOVE AND REERECT
STEEL PLATE BEAM GUARDRAIL**

(Sheet 1 of 4)

DETAIL

F.A. RTE.	SECTION	COUNTY	TOTAL SHEETS	SHEET NO.
55	99 (1&2) WRS-1	WILL	227	164B
FED. ROAD DIST. NO.		ILLINOIS	FED. AID PROJECT	

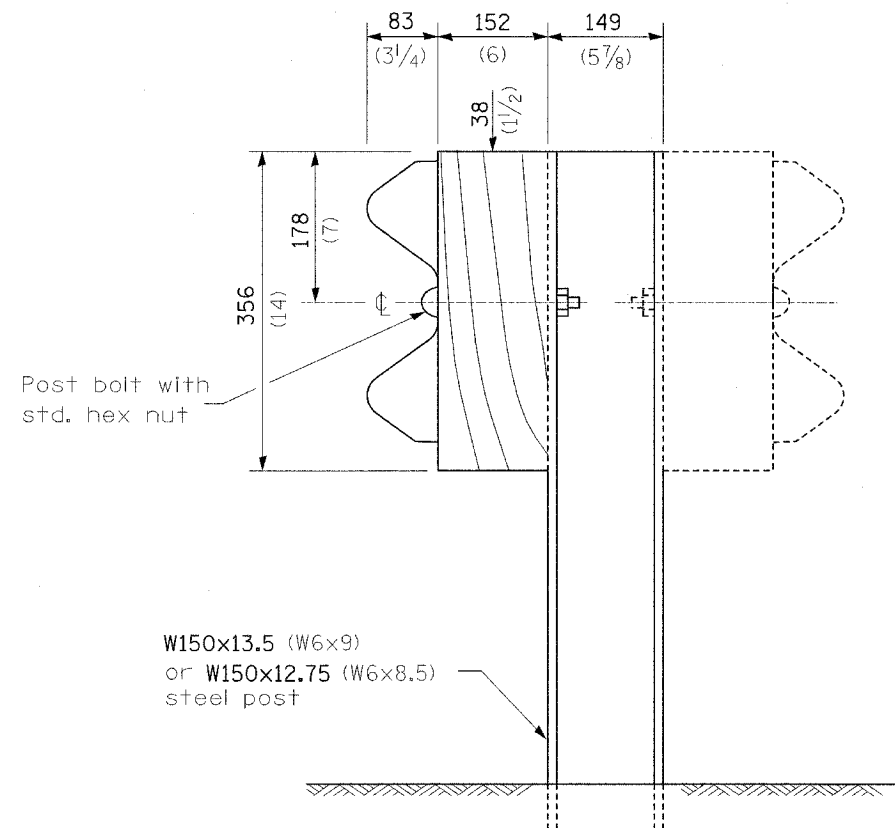

STEEL POST CONSTRUCTION

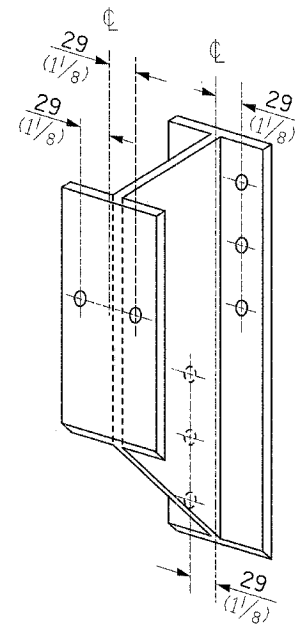

STEEL BLOCK-OUT DETAIL

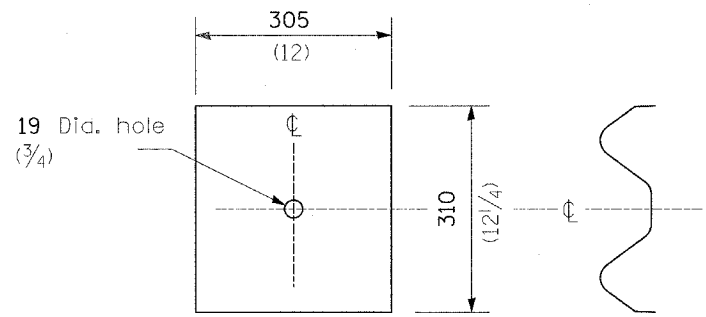

NOTE

Plate A shall be placed between rail element and block-out at non-splice mounting points only when steel block-outs are used.

PLATE A

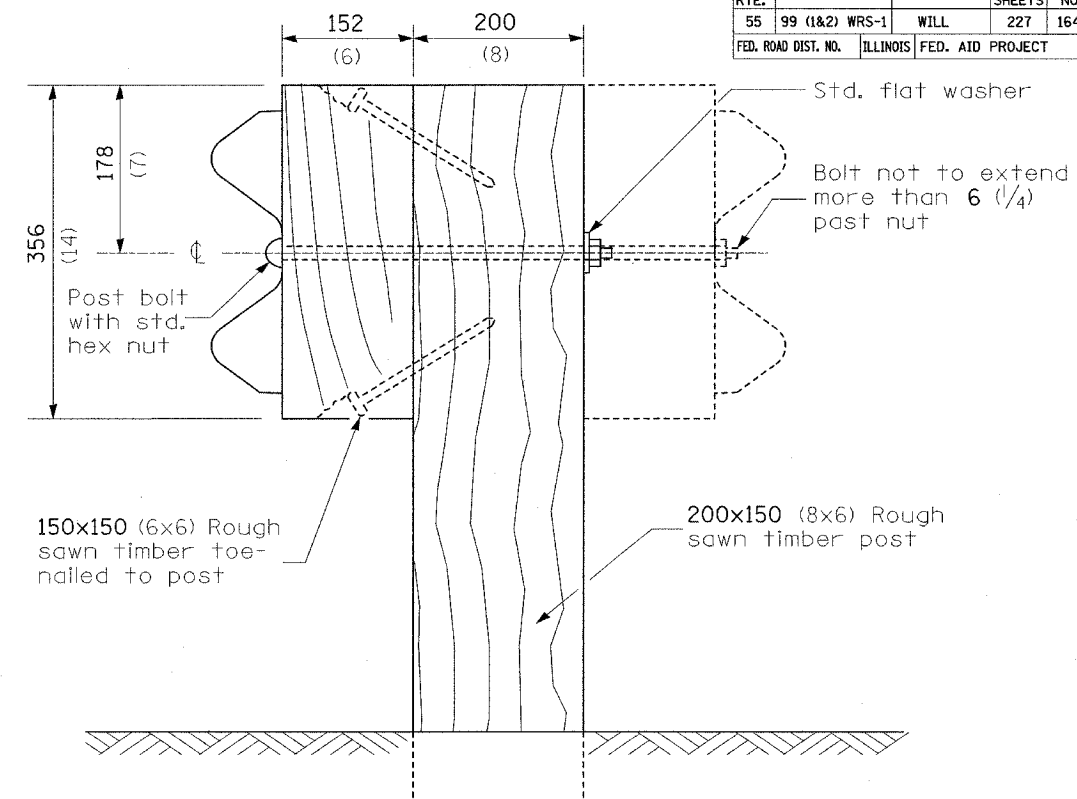

WOOD POST CONSTRUCTION

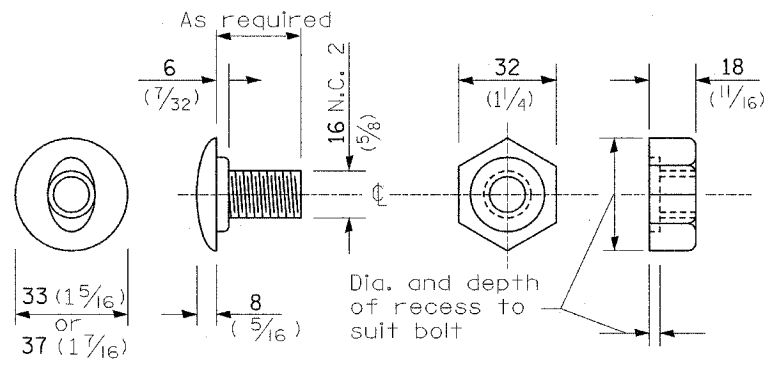

POST OR SPLICE BOLT & NUT

**REMOVE AND REERECT
STEEL PLATE BEAM GUARDRAIL**

(Sheet 2 of 4)

DETAIL

F.A. RTE.	SECTION	COUNTY	TOTAL SHEETS	SHEET NO.
55	99 (1&2) WRS-1	WILL.	227	164C
FED. ROAD DIST. NO.		ILLINOIS FED. AID PROJECT		

Place standard end shoe between splice plate and rail element

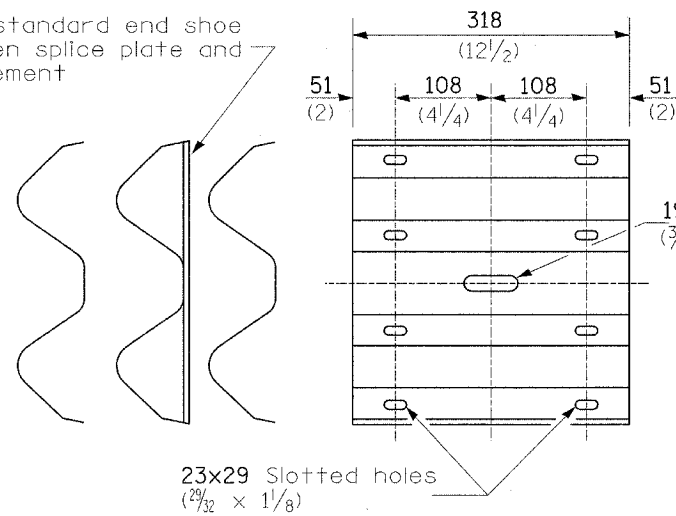

SPLICE PLATE

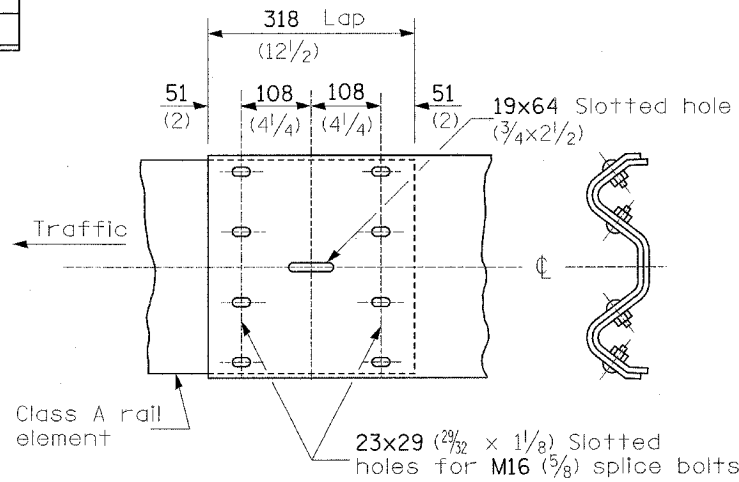

RAIL ELEMENT SPLICE

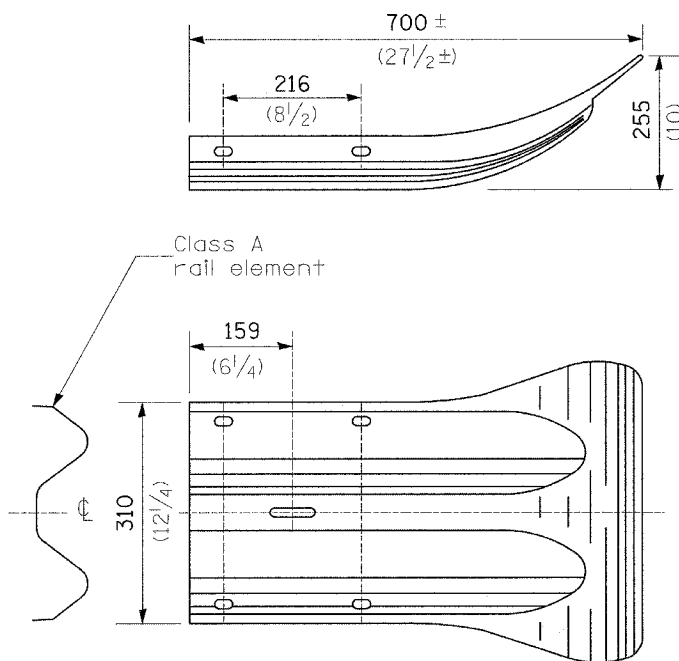

END SECTION

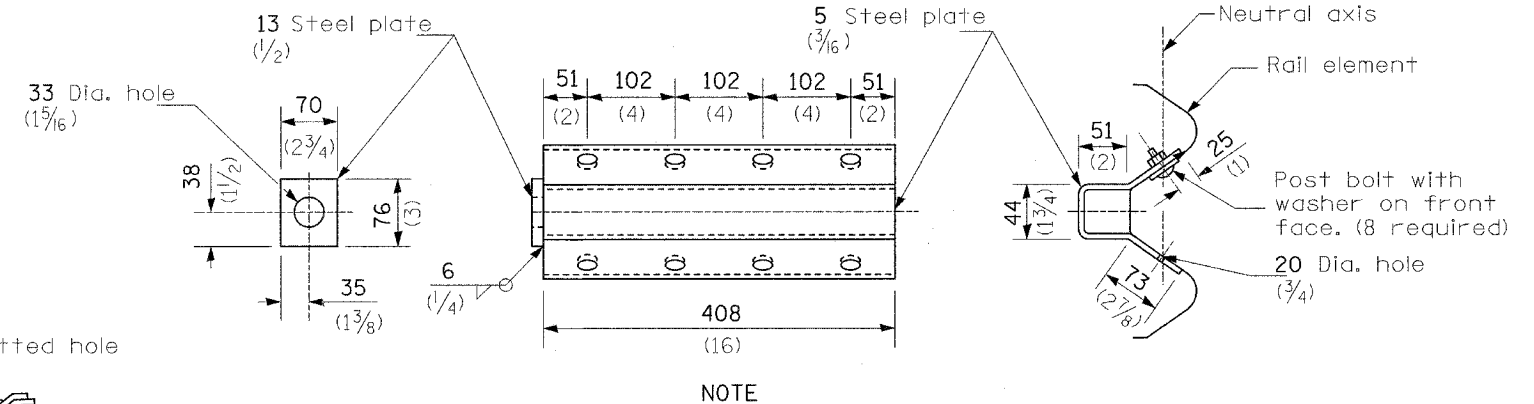

NOTE

Anchor plate T shall be used to attach cable assembly to guardrail when required on traffic barrier terminals.

ANCHOR PLATE T DETAILS

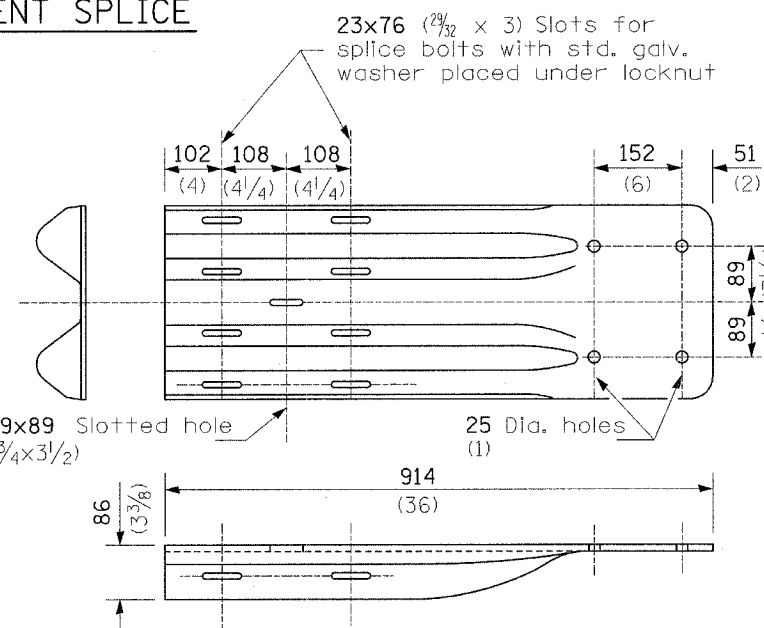

NOTE

When end shoe is attached to a bridge parapet which has an expansion joint, the bolts shall be provided with a locknut or double nut and shall be tightened only to a point that will allow guardrail movement.

The standard end shoe shall be attached to the concrete with pre-drilled or self-drilling anchor bolts. The anchor cone shall be set flush with the surface of the concrete.

Externally threaded studs protruding from the surface of the concrete will not be permitted.

END SHOE

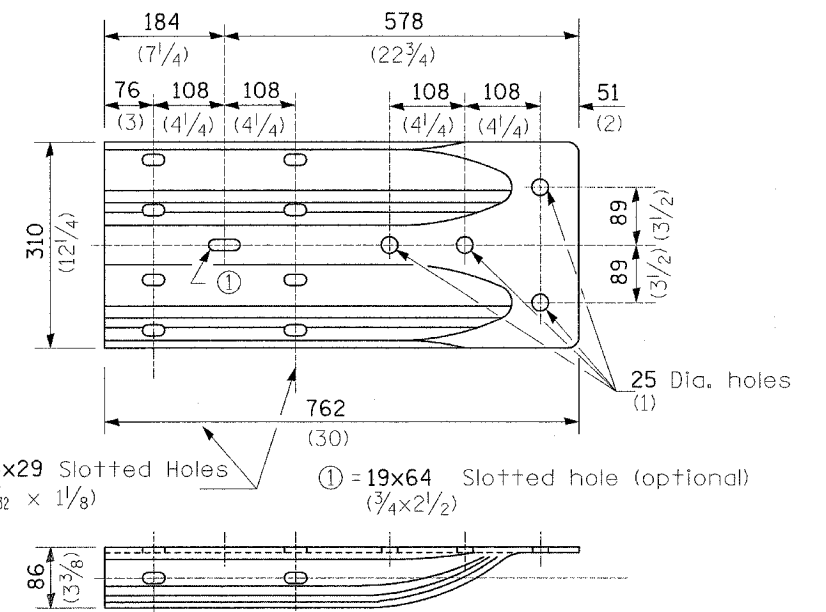

ALTERNATE END SHOE

REMOVE AND REERECT STEEL PLATE BEAM GUARDRAIL

(Sheet 3 of 4)

DETAIL

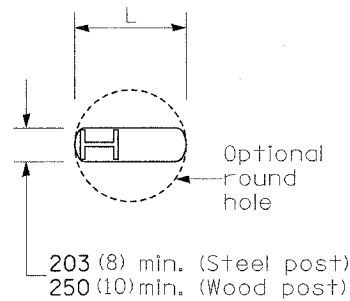

PLAN

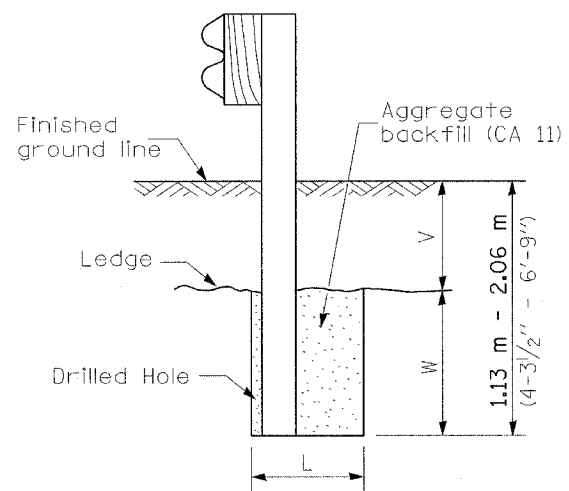

Note:
Ledge line is top of rock ledge or hard slag fill.

ELEVATION

FOOTING FOR POST WHEN IMPERVIOUS MATERIAL IS ENCOUNTERED

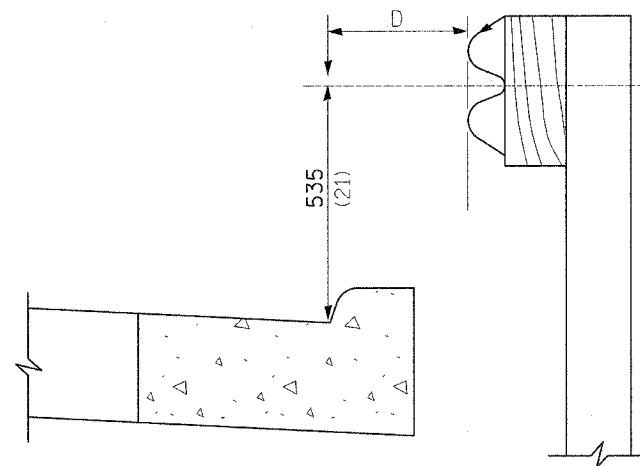

Note:

If it is necessary for D to be more than 300 (12) and less than 3.0 m (10'-0") type M-5 (M-2) curb and gutter (Std. 606001) shall be used in front of and in advance of the guardrail.

GUARDRAIL PLACED BEHIND CURB

(D = 0 desirable to 300 (12) maximum)

V	W	L	
		Steel Post	Wood Post
0 - 460 (0 - 18)	610 (24)	530 (21)	580 (23)
>460 - 825 (>18 - 41.5)	305 (12)	203 (8)	250 (10)
>825 - 1.13 m (>41.5 - 53.5)	305 - 0 (12 - 0)	203 (8)	250 (10)

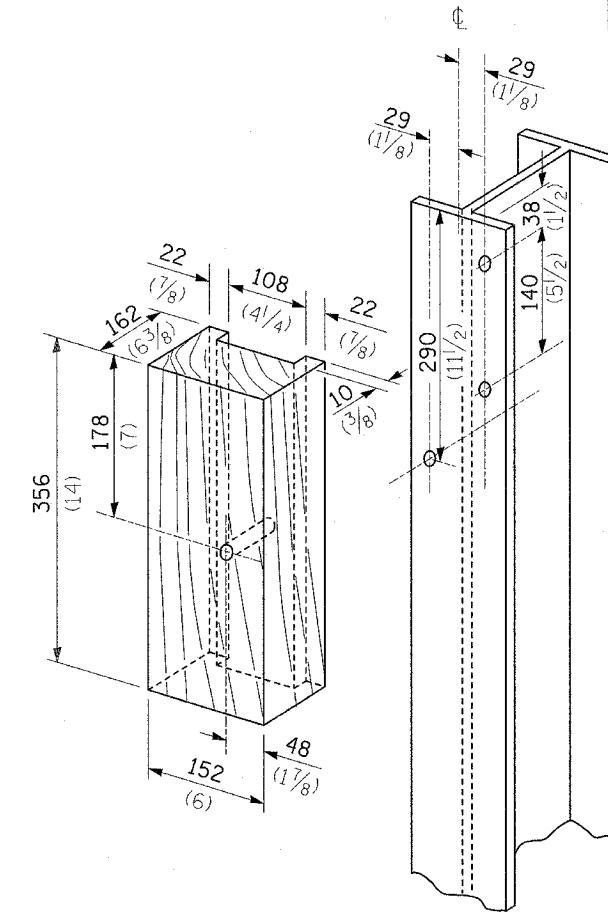

WOOD BLOCK-OUT AND STEEL POST DETAILS

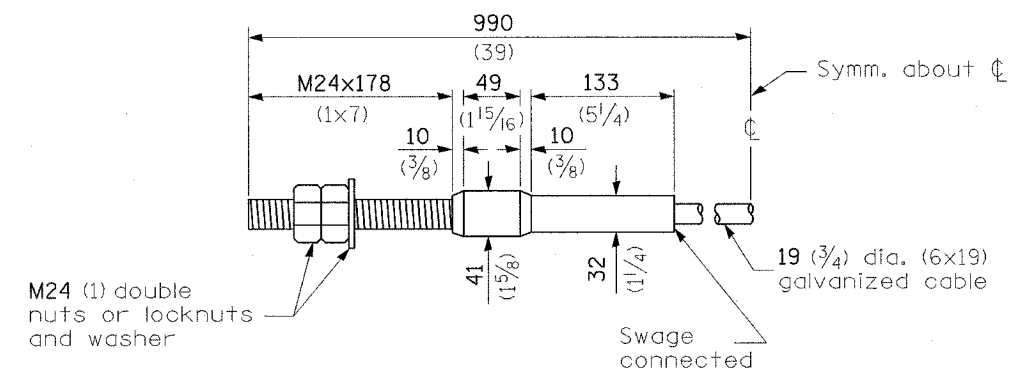

CABLE ASSEMBLY

(18,100 kg (40,000 lbs.) min. breaking strength)
Tighten to taut tension.

REMOVE AND REERECT STEEL PLATE BEAM GUARDRAIL

(Sheet 4 of 4)

DETAIL

F.A. RTE.	SECTION	COUNTY	TOTAL SHEETS	SHEET NO.
55	99 (1&2) WRS-3	WILL	227	164E
FED. ROAD DIST. NO.		ILLINOIS	FED. AID PROJECT	

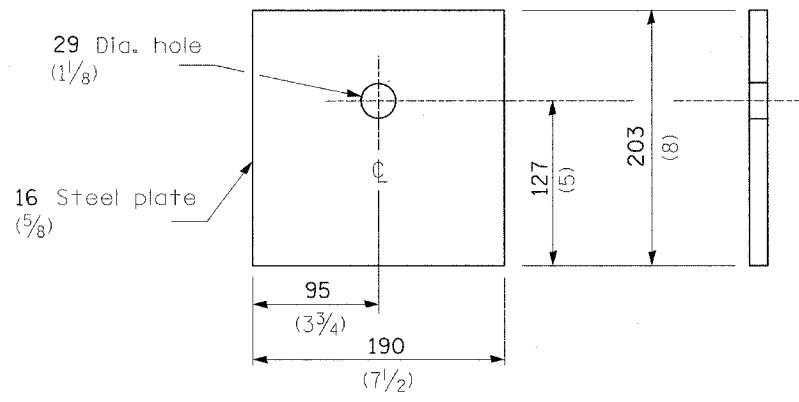

BEARING PLATE K

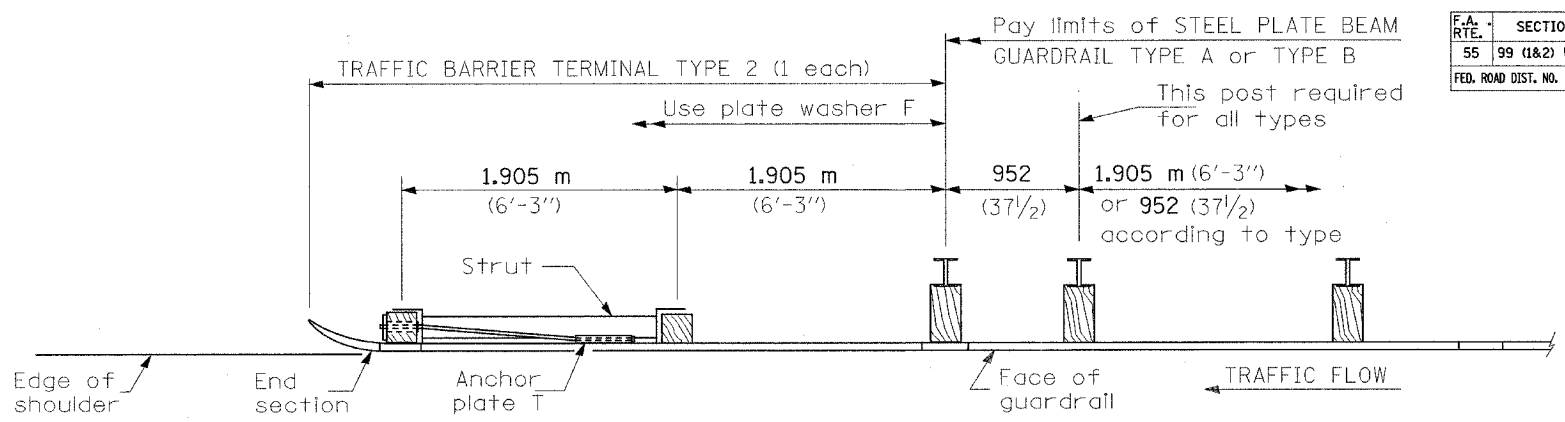

PLAN

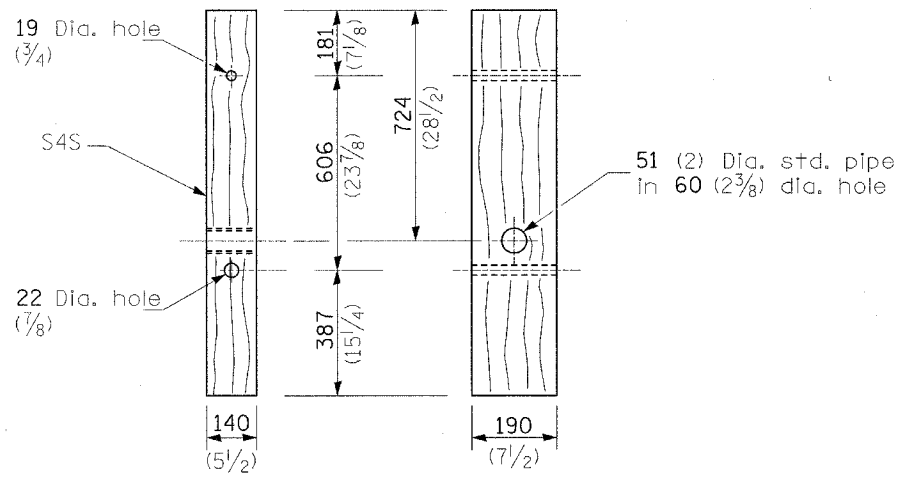

WOOD POST

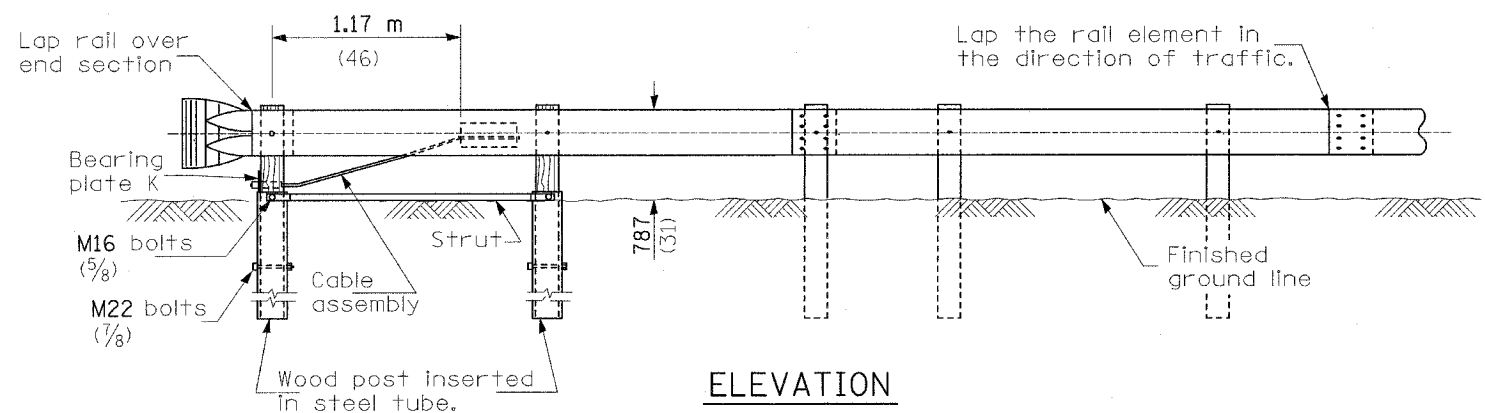

ELEVATION

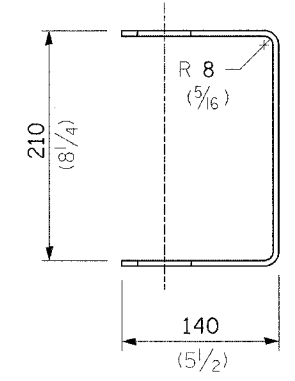

YOKE

5 (3/16) thick steel

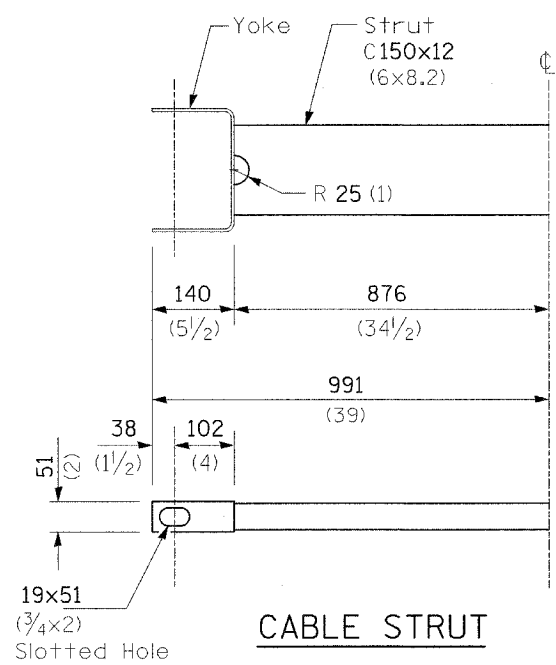

CABLE STRUT

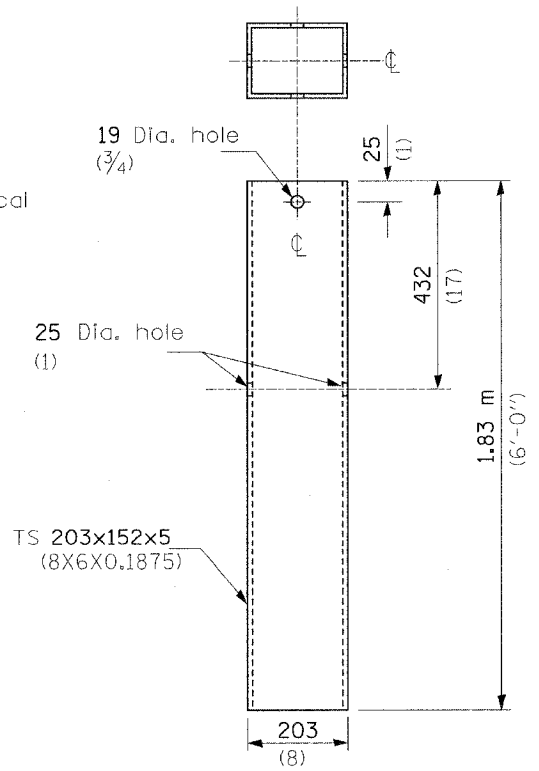

STEEL TUBE

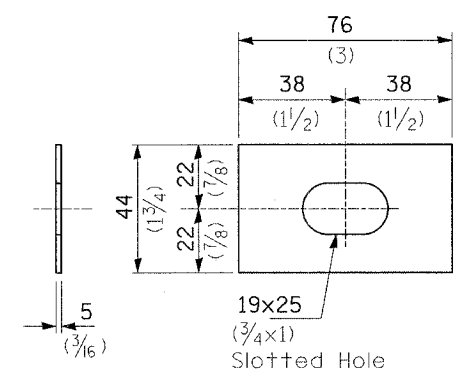

PLATE WASHER F

GENERAL NOTES

See Standard 630001 for details of guardrail not shown.
The bearing plate K shall be held in position by (2) two eight penny nails driven into the post and bent over the top of the plate.

All dimensions are in millimeters (inches) unless otherwise shown.

TRAFFIC BARRIER TERMINAL, TYPE 2

DETAIL

F.A.I. RTE.	SECTION	COUNTY	TOTAL SHEETS	SHEET NO.
55	99 (1&2) WRS-1	WILL	227	165
STA.		TO STA.		
FED. ROAD DIST. NO.		ILLINOIS FED. AID PROJECT		

I-55 MAINLINE

STAGE 1

LOCATION			UNSUITABLE EXCAVATION		EARTH EXCAVATION (CU YD)	EXCAVATION TO BE USED IN EMBANKMENT (ADJ. FOR SHRINKAGE 15%) (CU YD)	EMBANKMENT (CU YD)	EARTHWORK BALANCE WASTE (+) OR SHORTAGE (-) (CU YD)
			TOPSOIL (CU YD)	UNDERCUT (CU YD)				
594+66.36	TO	607+96.69	0	0	0	0	0	0
641+00.00	TO	700+00.00	2,755	6,740	5,310	4,515	-520	3,995
722+00.00	TO	751+75.00	1,420	2,035	2,615	2,225	-565	1,660

STAGE 2

LOCATION			UNSUITABLE EXCAVATION (CU YD)	EARTH EXCAVATION (CU YD)	TOPSOIL EXCAVATION AND PLACEMENT (CU YD)	EXCAVATION TO BE USED IN EMBANKMENT (ADJ. FOR SHRINKAGE 15%) (CU YD)	EMBANKMENT (CU YD)	EARTHWORK BALANCE WASTE (+) OR SHORTAGE (-) (CU YD)
641+00.00	TO	700+00.00	0	0	0	0	0	0
722+00.00	TO	751+75.00	0	0	0	0	0	0

US 30 NORTHBOUND ENTRANCE TO I-55

STAGE 2

LOCATION			UNSUITABLE EXCAVATION (CU YD)	EARTH EXCAVATION (CU YD)	TOPSOIL EXCAVATION AND PLACEMENT (CU YD)	EXCAVATION TO BE USED IN EMBANKMENT (ADJ. FOR SHRINKAGE 15%) (CU YD)	EMBANKMENT (CU YD)	EARTHWORK BALANCE WASTE (+) OR SHORTAGE (-) (CU YD)

STAGE 2A

LOCATION			UNSUITABLE EXCAVATION (CU YD)	EARTH EXCAVATION (CU YD)	TOPSOIL EXCAVATION AND PLACEMENT (CU YD)	EXCAVATION TO BE USED IN EMBANKMENT (ADJ. FOR SHRINKAGE 15%) (CU YD)	EMBANKMENT (CU YD)	EARTHWORK BALANCE WASTE (+) OR SHORTAGE (-) (CU YD)

US 30 SOUTHBOUND EXIT TO I-55

STAGE 2

LOCATION			UNSUITABLE EXCAVATION (CU YD)	EARTH EXCAVATION (CU YD)	TOPSOIL EXCAVATION AND PLACEMENT (CU YD)	EXCAVATION TO BE USED IN EMBANKMENT (ADJ. FOR SHRINKAGE 15%) (CU YD)	EMBANKMENT (CU YD)	EARTHWORK BALANCE WASTE (+) OR SHORTAGE (-) (CU YD)

STAGE 2A

LOCATION			UNSUITABLE EXCAVATION (CU YD)	EARTH EXCAVATION (CU YD)	TOPSOIL EXCAVATION AND PLACEMENT (CU YD)	EXCAVATION TO BE USED IN EMBANKMENT (ADJ. FOR SHRINKAGE 15%) (CU YD)	EMBANKMENT (CU YD)	EARTHWORK BALANCE WASTE (+) OR SHORTAGE (-) (CU YD)

NOTES:

- EXCAVATION TO BE USED AS EMBANKMENT ADJUSTED FOR 15% SHRINKAGE
- GRASS MEDIAN TOPSOIL AND VEGETATION SHALL BE REMOVED (ASSUMED 6 INCH DEPTH) AT THE CONTRACT UNIT PRICE FOR "REMOVAL AND DISPOSAL OF UNSUITABLE MATERIAL"
- OUTTER SIDESLOPE TOPSOIL AND VEGETATION SHALL BE REMOVED (ASSUMED 6 INCH DEPTH) AND 50% ASSUMED UNSUITABLE, PAID FOR AT THE CONTRACT UNIT PRICE FOR "REMOVAL AND DISPOSAL OF UNSUITABLE MATERIAL" AND 50% ASSUMED SUITABLE, PAID FOR AT THE CONTRACT UNIT PRICE FOR "TOPSOIL EXCAVATION AND PLACEMENT"
- VOLUMES ARE CALCULATED USING END AREAS SHOWN ON SHEET 165A. THESE END AREAS SUPERCEDE AREAS SHOWN ON CROSS SECTIONS.

EARTHWORK SUMMARY

	UNSUITABLE EXCAVATION (CU YD)	EARTH EXCAVATION (CU YD)	TOPSOIL EXCAVATION AND PLACEMENT (CU YD)	TOPSOIL FURNISH AND PLACE (6") (SQ YD)
TOTAL	13,425	9,650	475	2,285

REVISIONS	
NAME	DATE

ILLINOIS DEPARTMENT OF TRANSPORTATION
FAI ROUTE 55
US 30 (PLAINFIELD ROAD) TO 143RD STREET

EARTHWORK SCHEDULE

SCALE:
DATE: 02-23-07

DRAWN BY MGH
CHECKED BY RMH



FINAL

CONTRACT NO. 62896				
F.A. RTE.	SECTION	COUNTY	TOTAL SHEETS	SHEET NO.
55	99 (I&2) WRS-1	WILL	227	166
STA. 594+66.36		TO STA. 595+00.00		
FED. ROAD DIST. NO.	ILLINOIS	FED. AID PROJECT		

BY: _____ DATE: _____

FINAL SURVEY SURVEYED _____
 PLOTTED _____
 NOTE BOOK _____
 AREAS CHECKED _____
 NO. _____

BY: _____ DATE: _____

ORIGINAL SURVEY SURVEYED _____
 PLOTTED _____
 NOTE BOOK _____
 AREAS CHECKED _____
 NO. _____

PLOT DATE = 2/15/2007
 FILE NAME = #FILE#
 PLOT SCALE = #SCALE#
 USER NAME = #USER#

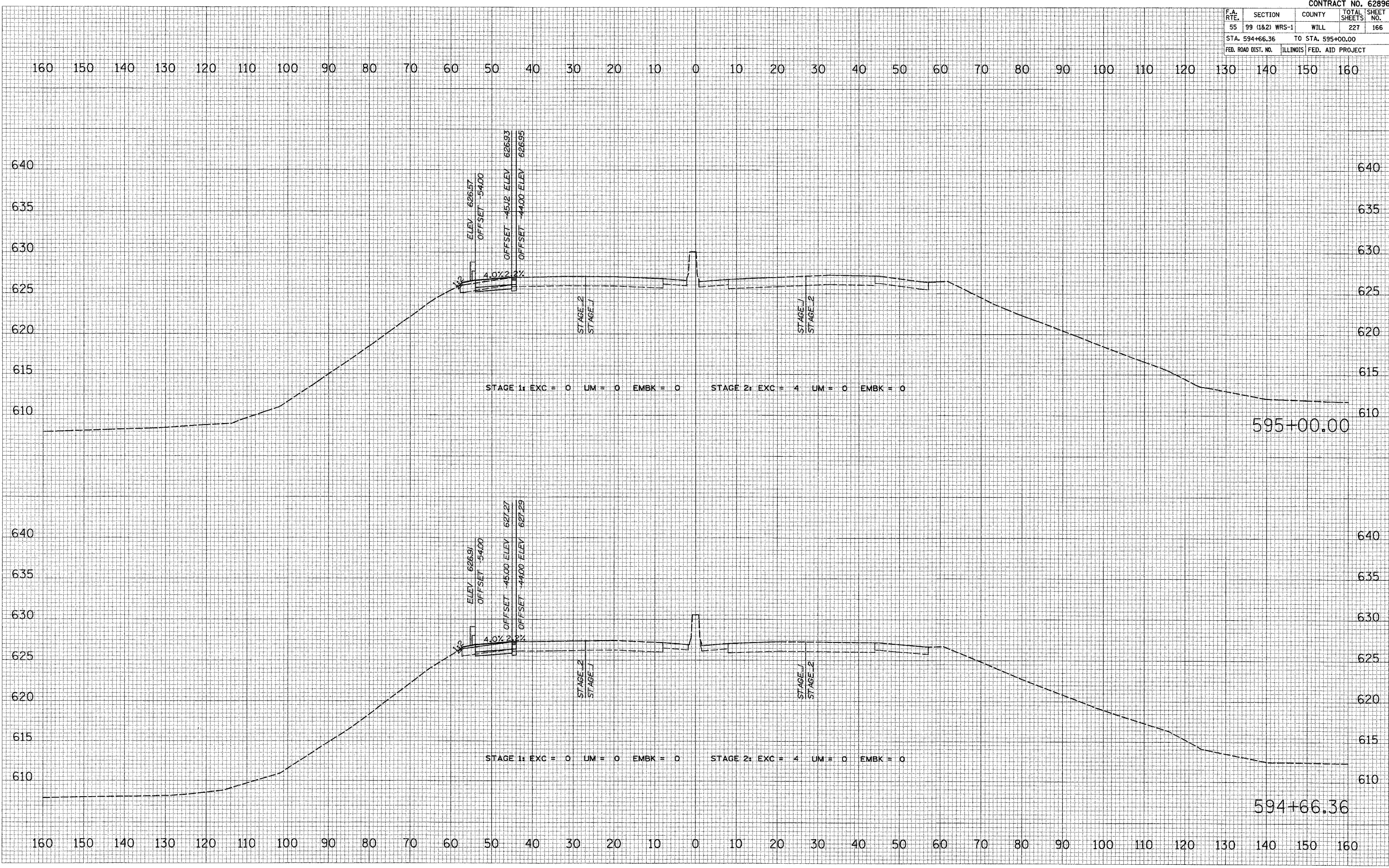

I-55 MAINLINE

CONTRACT NO. 62896				
F.A. RTE.	SECTION	COUNTY	TOTAL SHEETS	SHEET NO.
55	99 (1&2) WRS-1	WILL	227	167
STA. 596+00.00		TO STA. 597+00.00		
FED. ROAD DIST. NO.		ILLINOIS FED. AID PROJECT		

FINAL SURVEY PLOTTED NOTE BOOK NO. _____

DATE _____

ORIGINAL SURVEY PLOTTED NOTE BOOK NO. _____

DATE _____

PLT DATE = 2/19/2007
 PLT BY = MCB
 USER NAME = MUSER*

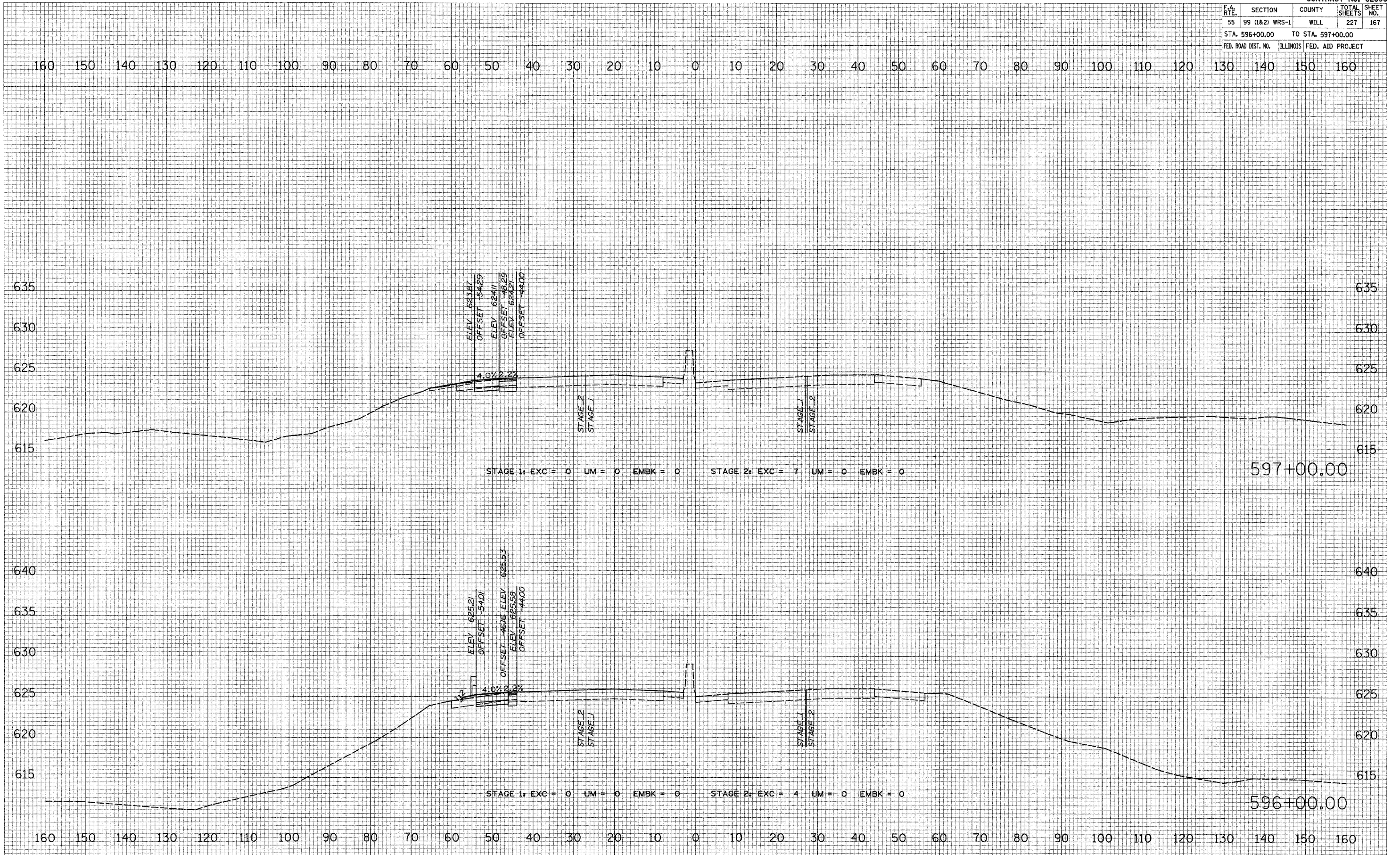

I-55 MAINLINE

CONTRACT NO. 62896					
F.A. RTE.	SECTION	COUNTY	TOTAL SHEETS	SHEET NO.	
55	99 (I&2) WRS-1	WILL	227	168	
STA. 598+00.00 TO STA. 600+00.00					
FED. ROAD DIST. NO. ILLINOIS FED. AID PROJECT					

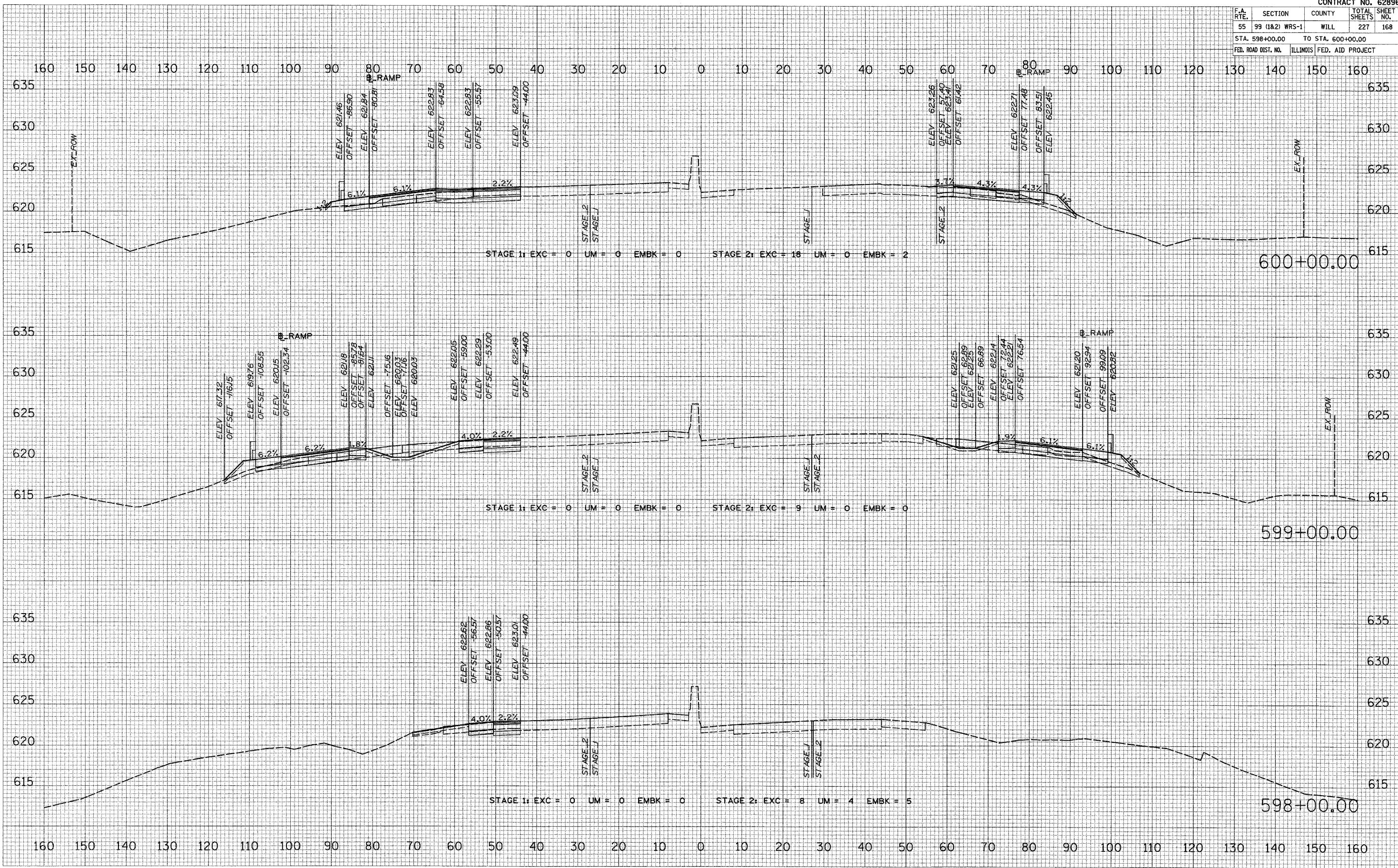

DATE: _____ BY: _____

FINAL SURVEY: _____

PLOTTED: _____

SCALE: _____

NOTE BOOK NO.: _____

AREAS CHECKED: _____

DATE: _____ BY: _____

ORIGINAL SURVEY: _____

PLOTTED: _____

SCALE: _____

NOTE BOOK NO.: _____

AREAS CHECKED: _____

DATE: 2/17/97

FILE NAME: I-55 MAINLINE

PLOT SCALE: AS SHOWN

USER NAME: RUSBR

CONTRACT NO. 62896				
F.A. RTE.	SECTION	COUNTY	TOTAL SHEETS	SHEET NO.
55	99 (1&2) WRS-1	WILL	227	169
STA. 601+00.00		TO STA. 603+00.00		
FED. ROAD DIST. NO.		ILLINOIS FED. AID PROJECT		

DATE	BY
DESIGNED	
PLOTTED	
TEMPLATE	
AREAS	
CHECKED	
NO.	
FINAL SURVEY	
NOTE BOOK	
NO.	

DATE	BY
DESIGNED	
PLOTTED	
TEMPLATE	
AREAS	
CHECKED	
NO.	
ORIGINAL SURVEY	
NOTE BOOK	
NO.	

PLOT DATE = 2/19/2017
 FILE NAME = #FILE#
 USER NAME = #USER#

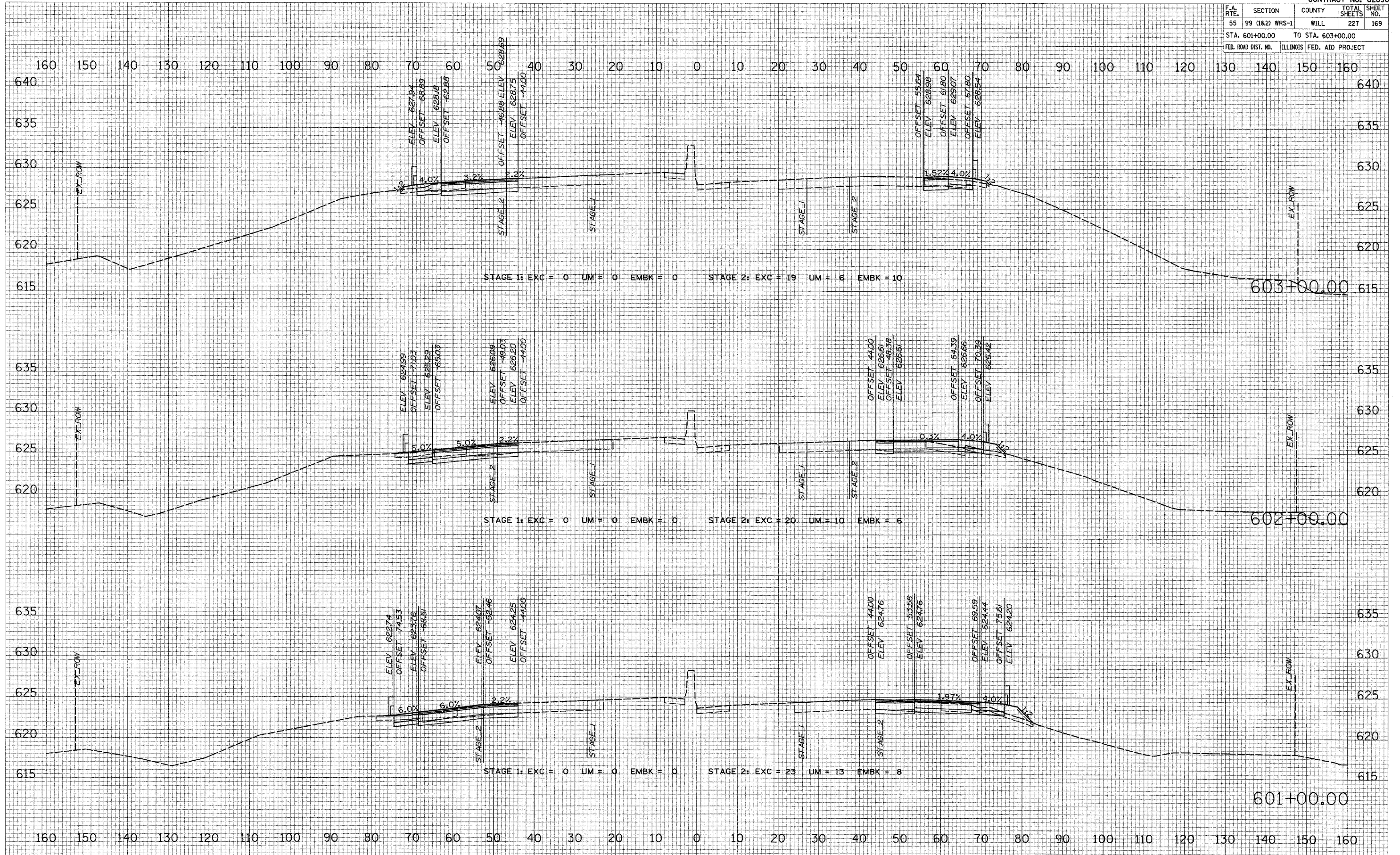

I-55 MAINLINE

CONTRACT NO. 62896				
F.A. RTE.	SECTION	COUNTY	TOTAL SHEETS	SHEET NO.
55	99 (1&2) WRS-1	WILL	227	170
STA. 604+00.00 TO STA. 605+00.00				
FED. ROAD DIST. NO.		ILLINOIS	FED. AID PROJECT	

DATE: _____ BY: _____

FINAL SURVEY: _____
 SURVEY PLOTTED: _____
 NOTE BOOK: _____
 AREAS CHECKED: _____

DATE: _____ BY: _____

ORIGINAL SURVEY: _____
 SURVEY PLOTTED: _____
 NOTE BOOK: _____
 AREAS CHECKED: _____

PLOT DATE: _____
 FILE NAME: _____
 PLOT SCALE: _____
 USER NAME: _____

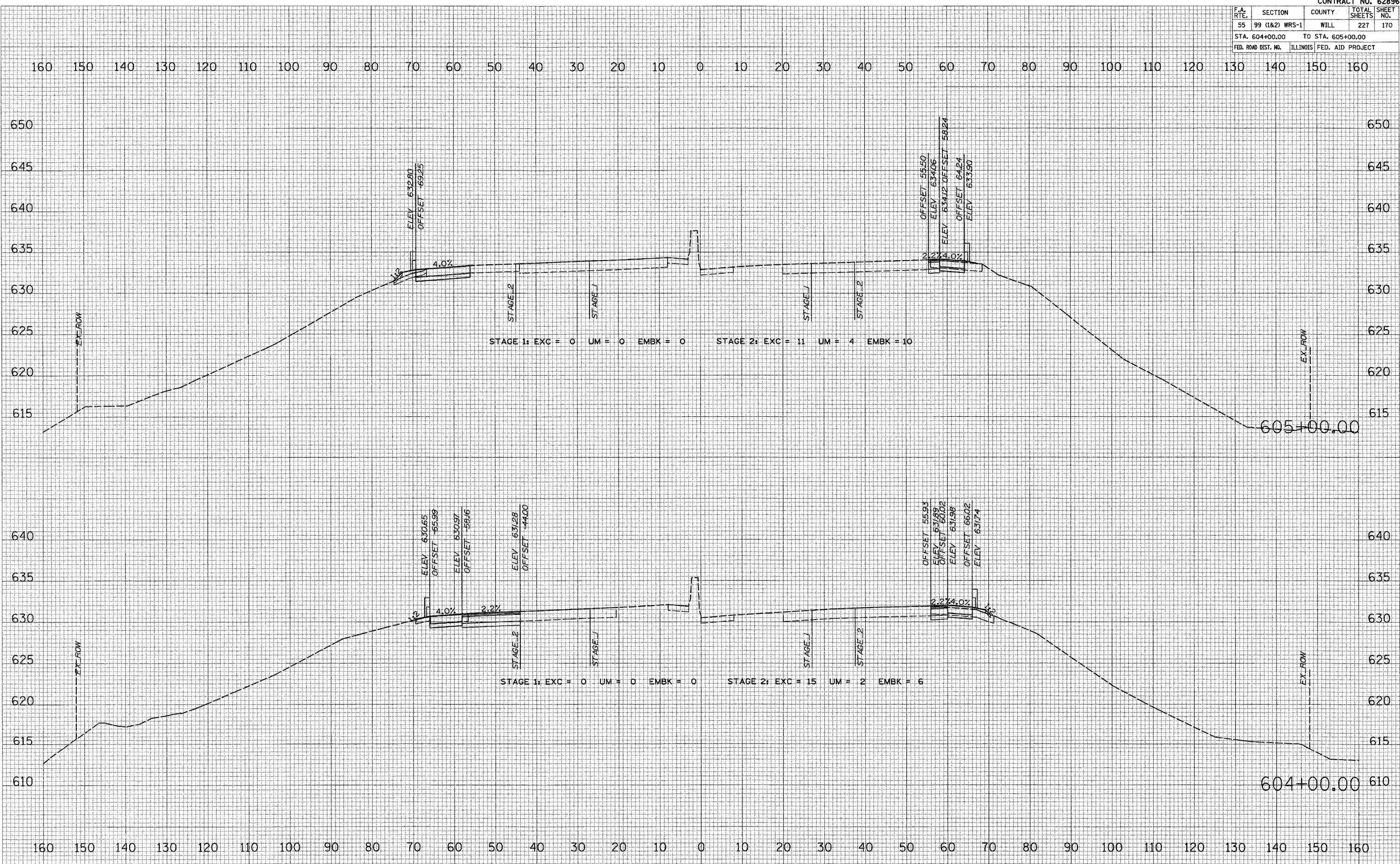

I-55 MAINLINE

CONTRACT NO. 62896				
F.A. RTE.	SECTION	COUNTY	TOTAL SHEETS	SHEET NO.
55	99 (1&2) WRS-1	WILL	227	171
STA. 606+00.00		TO STA. 607+00.00		
FED. ROAD DIST. NO.		ILLINOIS FED. AID PROJECT		

DATE _____ BY _____
 SURVEYED _____
 PLOTTED _____
 NOTE BOOK _____
 AREAS CHECKED _____

DATE _____ BY _____
 SURVEYED _____
 PLOTTED _____
 NOTE BOOK _____
 AREAS CHECKED _____

PLOT DATE = 2/19/2007
 FILE NAME = #171
 PLOT SCALE = #18CA
 USER NAME = #18BR#

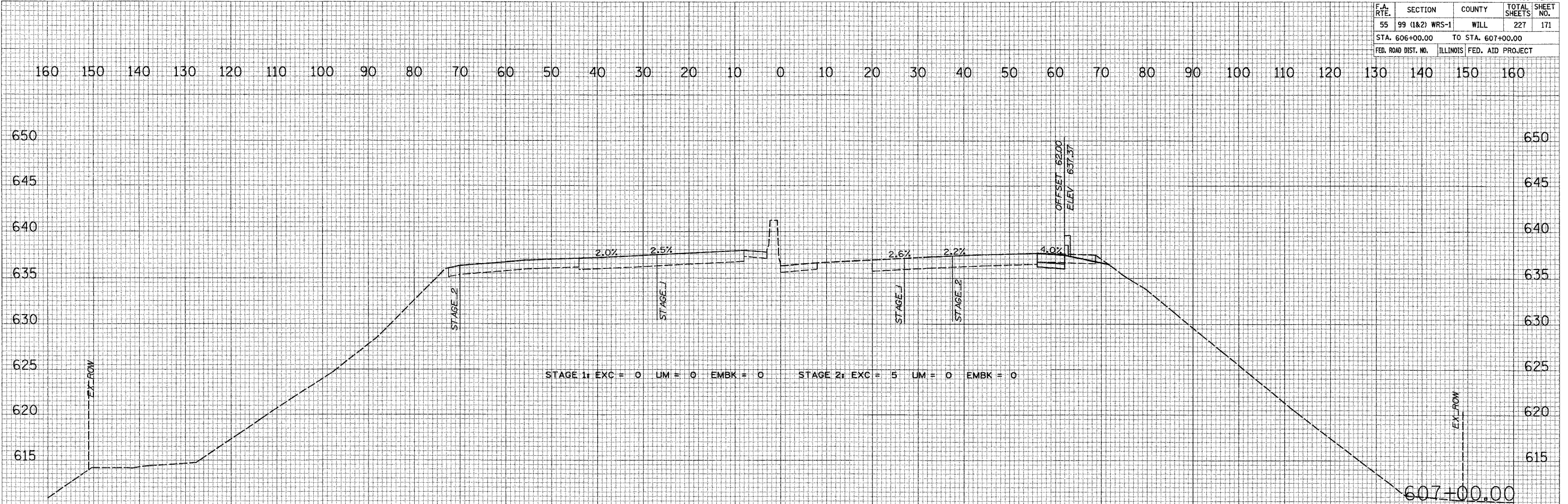

I-55 MAINLINE

CONTRACT NO. 62896				
F.A. RTE.	SECTION	COUNTY	TOTAL SHEETS	SHEET NO.
55	99 (1&2) WRS-1	WILL	227	173
STA. 642+00.00		TO STA. 642+75.00		
FED. ROAD DIST. NO.		ILLINOIS FED. AID PROJECT		

DATE: _____
 BY: _____
 SURVEYED: _____
 PLOTTED: _____
 NOTE BOOK: _____
 AREAS CHECKED: _____

DATE: _____
 BY: _____
 SURVEYED: _____
 PLOTTED: _____
 NOTE BOOK: _____
 AREAS CHECKED: _____

DATE: 2/13/2007
 FILE NAME: #FILE#
 PLOT SCALE: #SCALE#
 USER NAME: #USER#

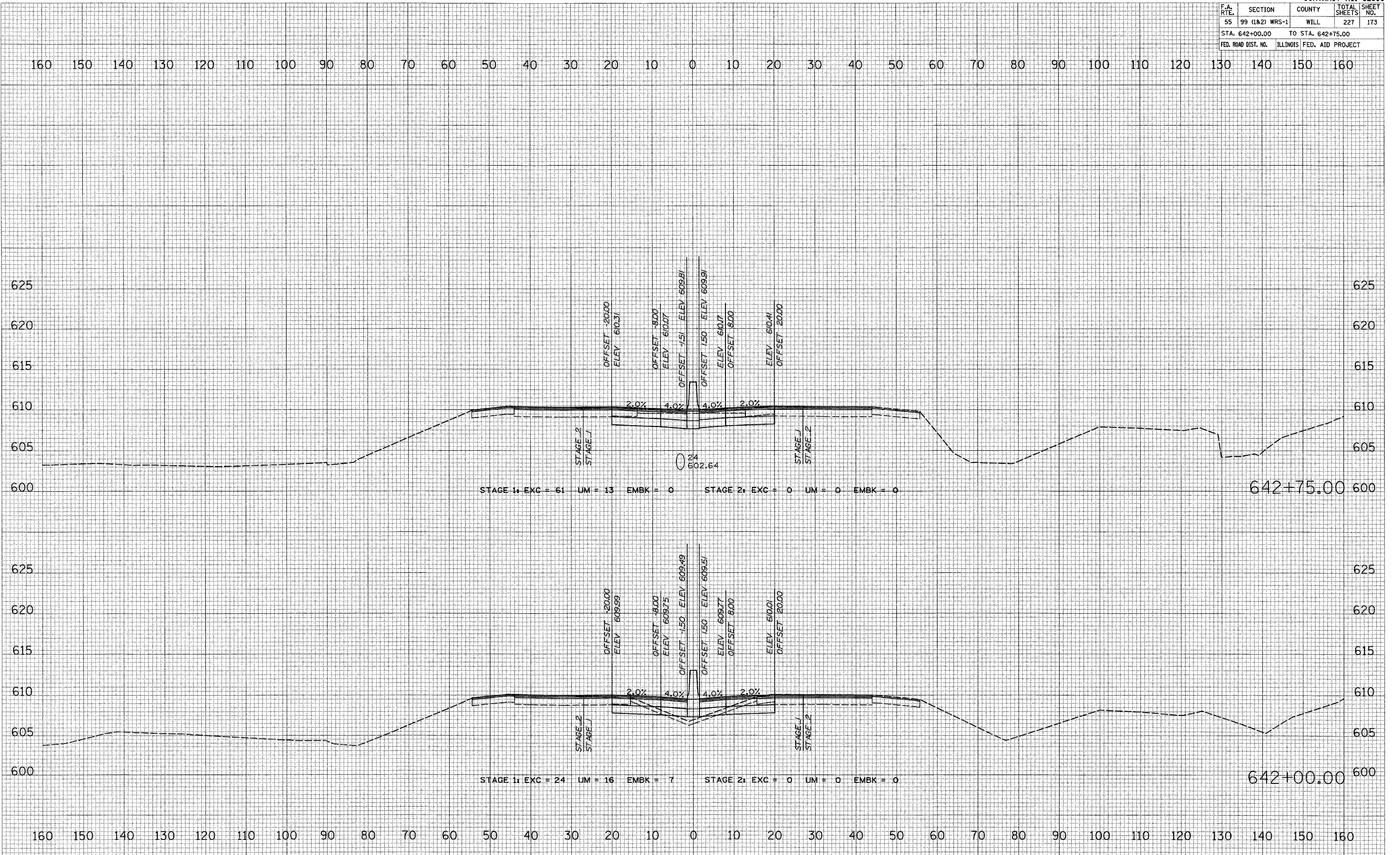

I-55 MAINLINE

CONTRACT NO. 62896				
F.A. RTE.	SECTION	COUNTY	TOTAL SHEETS	SHEET NO.
55	99 (1&2) WRS-1	WILL	227	174
STA. 643+00.00 TO STA. 644+00.00				
FED. ROAD DIST. NO. ILLINOIS FED. AID PROJECT				

DATE: _____
 BY: _____
 SURVEYED: _____
 PLOTTED: _____
 NOTE BOOK: _____
 AREAS CHECKED: _____
 NO. _____

DATE: _____
 BY: _____
 SURVEYED: _____
 PLOTTED: _____
 NOTE BOOK: _____
 AREAS CHECKED: _____
 NO. _____

DATE: 2/19/2007
 FILE NAME: #SCALE
 PLOT SCALE: #SCALE
 USER NAME: #USER#

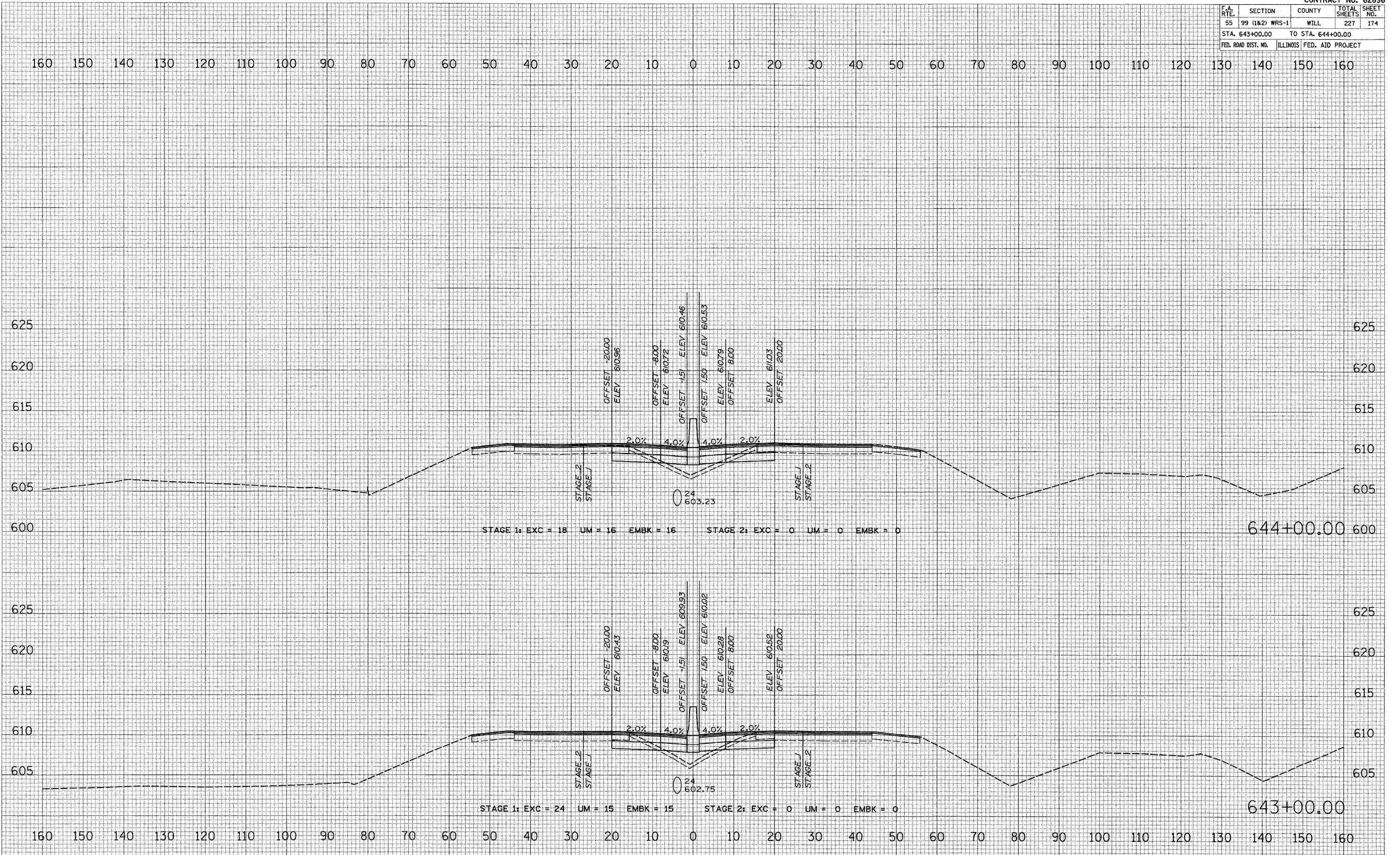

I-55 MAINLINE

F.A. RTE.	SECTION	COUNTY	TOTAL SHEETS	SHEET NO.
55	99 (1&2) WRS-1	WILL	227	176
STA. 647+00.00 TO STA. 648+00.00				
FED. ROAD DIST. NO. [ILLINOIS] FED. AID PROJECT				

FINAL SURVEY	SURVEYED	BY	DATE
NOTE BOOK	PLOTTED		
NO.	AREAS CHECKED		

ORIGINAL SURVEY	SURVEYED	BY	DATE
NOTE BOOK	PLOTTED		
NO.	AREAS CHECKED		

PLOT DATE = 2/10/2007
 FILE NAME = #FILE#
 PLOT SCALE = #SCALE#
 USER NAME = #USER#

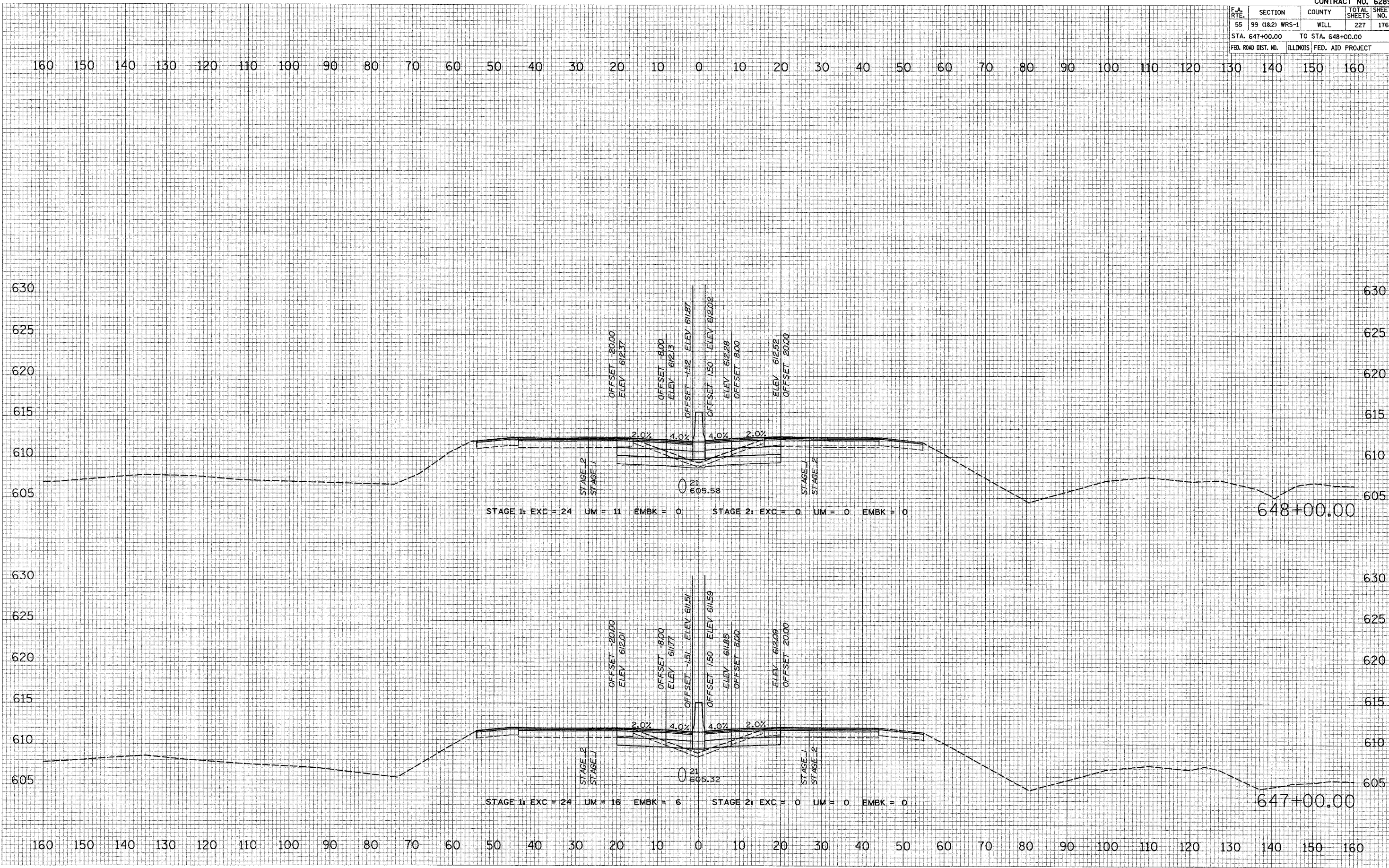

CONTRACT NO. 62896				
F.A. RTE.	SECTION	COUNTY	TOTAL SHEETS	SHEET NO.
55	99 (1&2) WRS-1	WILL	227	177
STA. 649+00.00		TO STA. 650+00.00		
FED. ROAD DIST. NO.		ILLINOIS FED. AID PROJECT		

DATE _____
 BY _____
 SURVEYED _____
 PLOTTED _____
 NOTE BOOK _____
 AREAS CHECKED _____
 NO. _____

DATE _____
 BY _____
 SURVEYED _____
 PLOTTED _____
 NOTE BOOK _____
 AREAS CHECKED _____
 NO. _____

2/18/2007
 FILE NAME = 815L
 PLOT SCALE = 1/8"=1'-0"
 USER NAME = MUSER

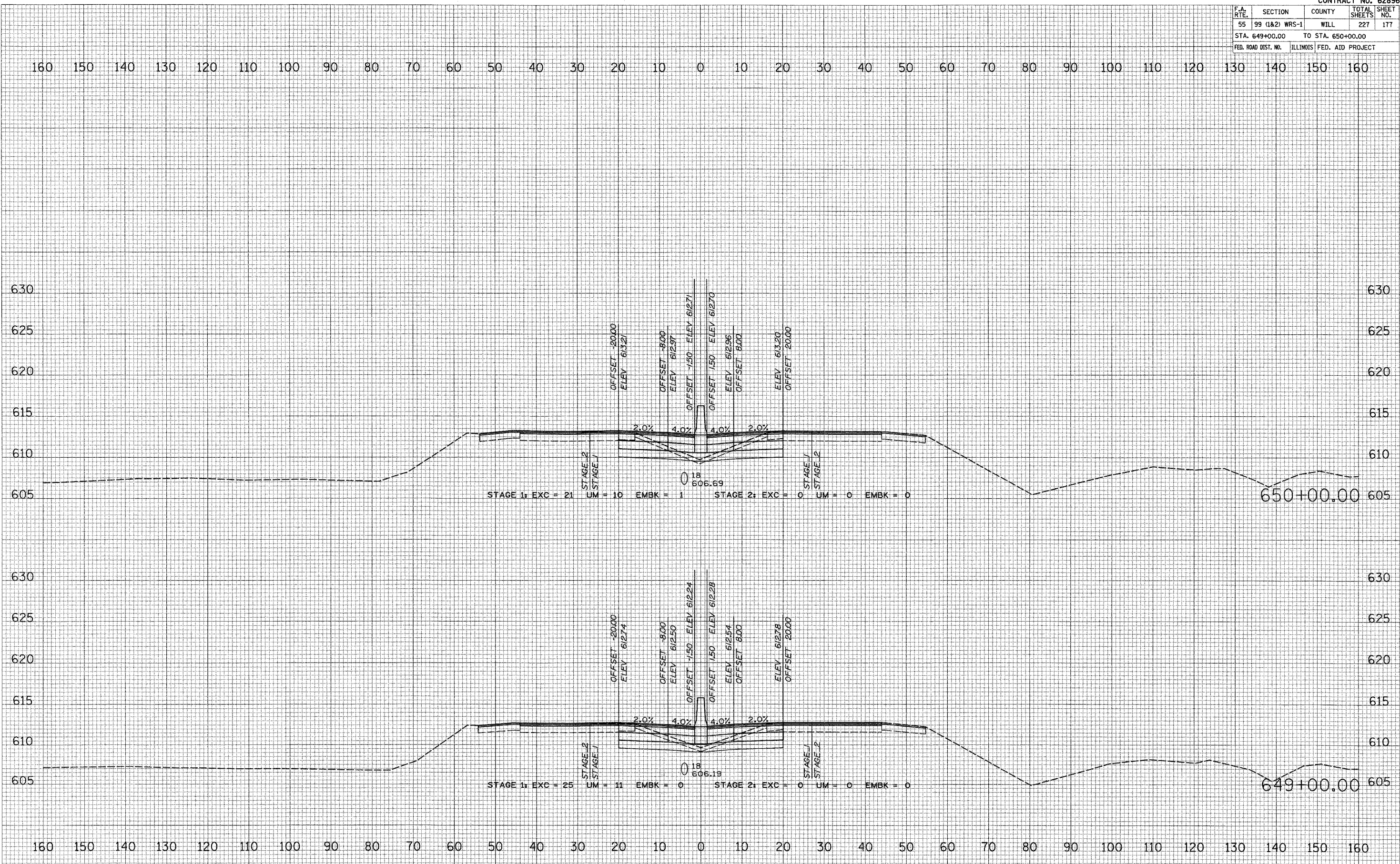

CONTRACT NO. 62896				
F.A. RTE.	SECTION	COUNTY	TOTAL SHEETS	SHEET NO.
55	99 (1&2) WRS-1	WILL	227	178
STA. 651+00.00		TO STA. 652+00.00		
FED. ROAD DIST. NO.	ILLINOIS	FED. AID PROJECT		

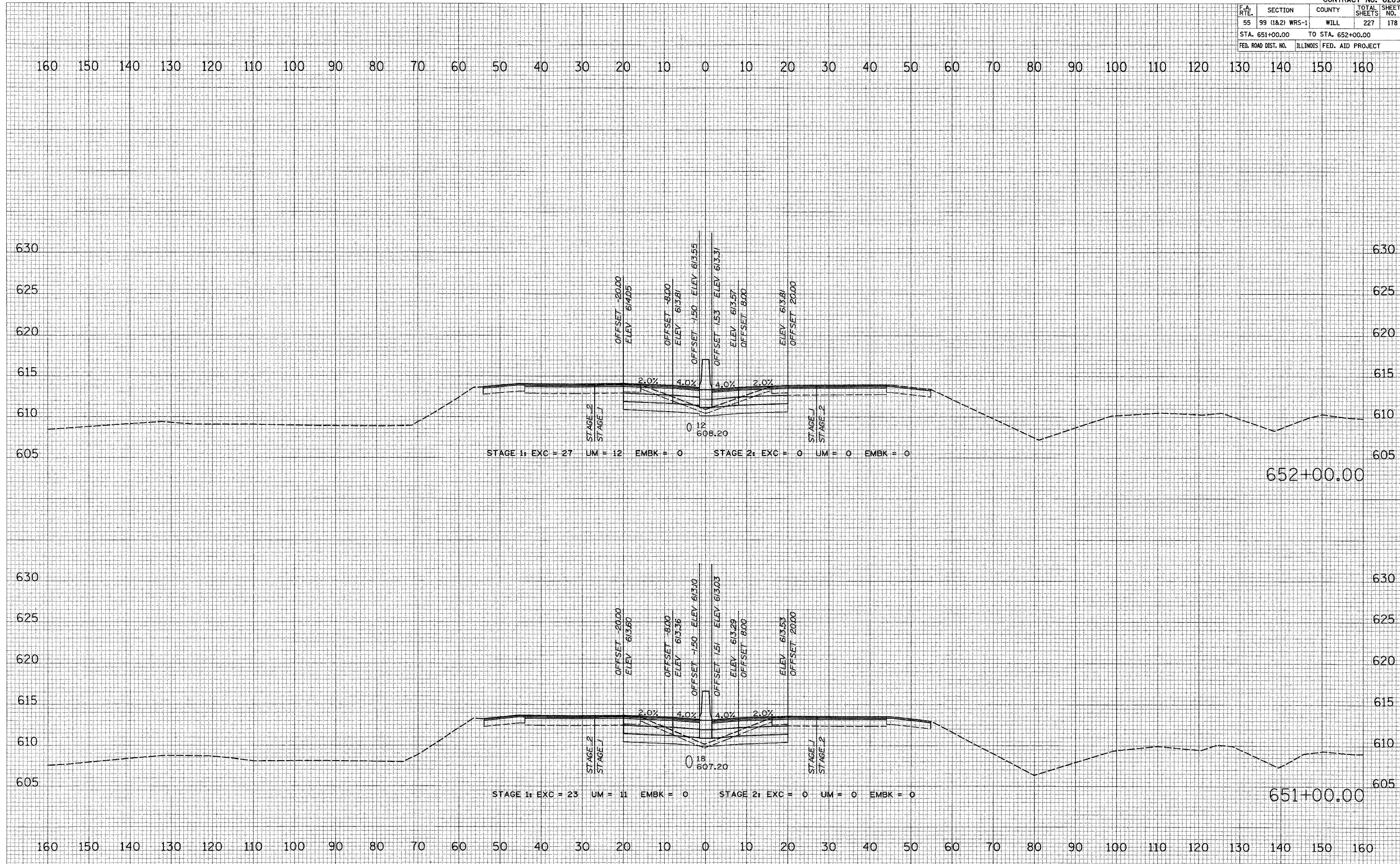

FINAL SURVEY
 SURVEYED BY
 PLOTTED BY
 NOTE BOOK NO.
 TEMPLATE AREAS
 AREAS CHECKED

ORIGINAL SURVEY
 SURVEYED BY
 PLOTTED BY
 NOTE BOOK NO.
 TEMPLATE AREAS
 AREAS CHECKED

PLOT DATE = 2/19/2007
 FILE NAME = FILE1
 PLOT SCALE = 60/1
 USER NAME = BUSENB

CONTRACT NO. 62896				
F.A. RTE.	SECTION	COUNTY	TOTAL SHEETS	SHEET NO.
55	99 (1&2) WRS-1	WILL	227	179
STA. 653+00.00		TO STA. 654+00.00		
FED. ROAD DIST. NO.		ILLINOIS FED. AID PROJECT		

FINAL SURVEY
 SURVEYED BY
 DATE
 PLANTED
 DATE
 NOTE BOOK NO.
 AREAS CHECKED

ORIGINAL SURVEY
 SURVEYED BY
 DATE
 PLANTED
 DATE
 NOTE BOOK NO.
 AREAS CHECKED

PLOT DATE = 2/19/2007
 FILE NAME = #FILEL
 PLOT SCALE = #SCALE
 USER NAME = #USERB

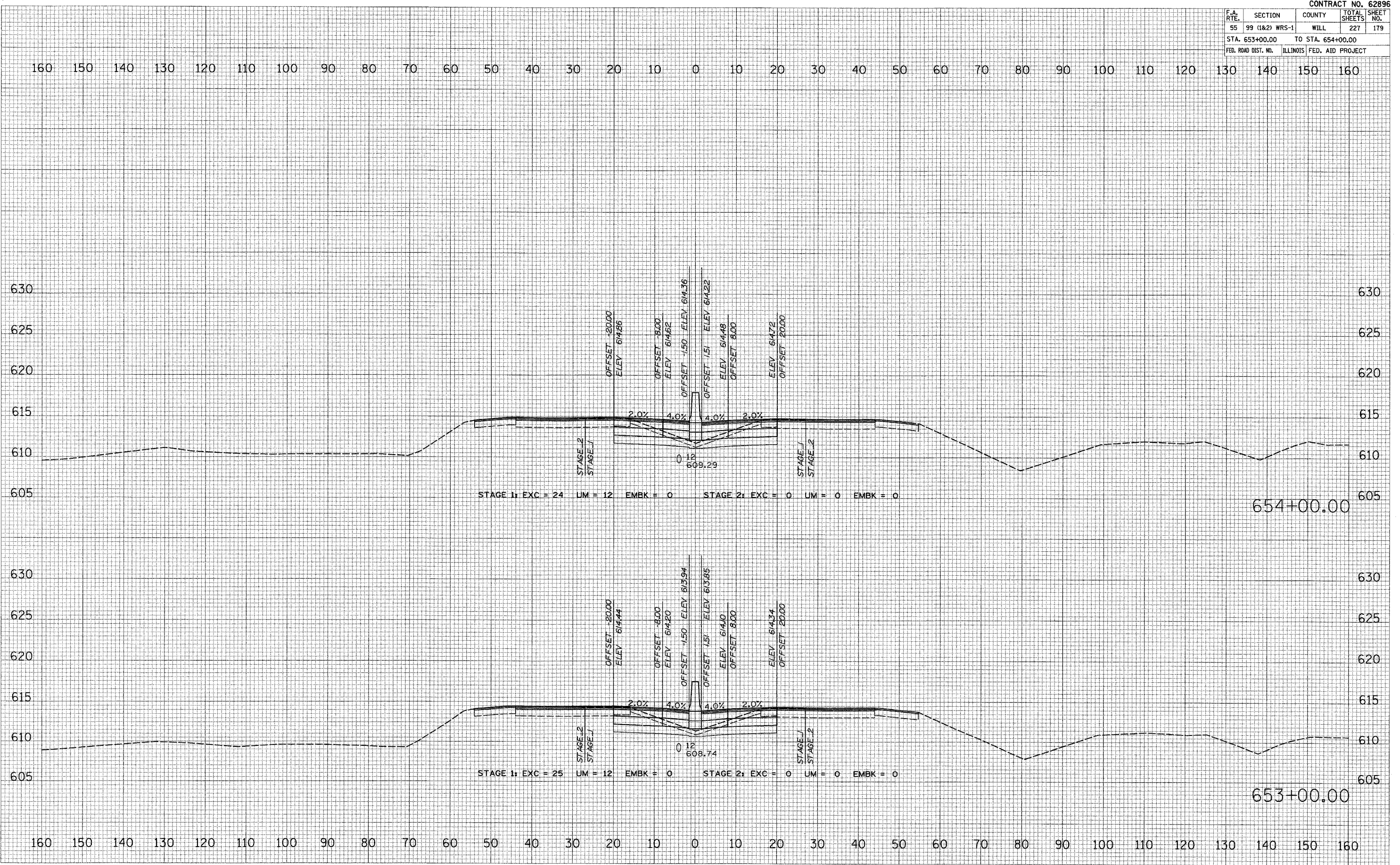

I-55 MAINLINE

CONTRACT NO. 62896				
F.A. RTE.	SECTION	COUNTY	TOTAL SHEETS	SHEET NO.
55	99 (1&2) WRS-1	WILL	227	180
STA. 655+00.00 TO STA. 656+00.00				
FED. ROAD DIST. NO. ILLINOIS FED. AID PROJECT				

BY: _____ DATE: _____

FINAL SURVEY SURVEYED _____
 PLOTTED _____
 NOTE BOOK _____
 AREAS CHECKED _____
 NO. _____

BY: _____ DATE: _____

ORIGINAL SURVEY SURVEYED _____
 PLOTTED _____
 NOTE BOOK _____
 AREAS CHECKED _____
 NO. _____

PLT DATE = 2/18/2007
 FILE NAME = 01111
 PLOT SCALE = 8000:1
 USER NAME = BUSER0

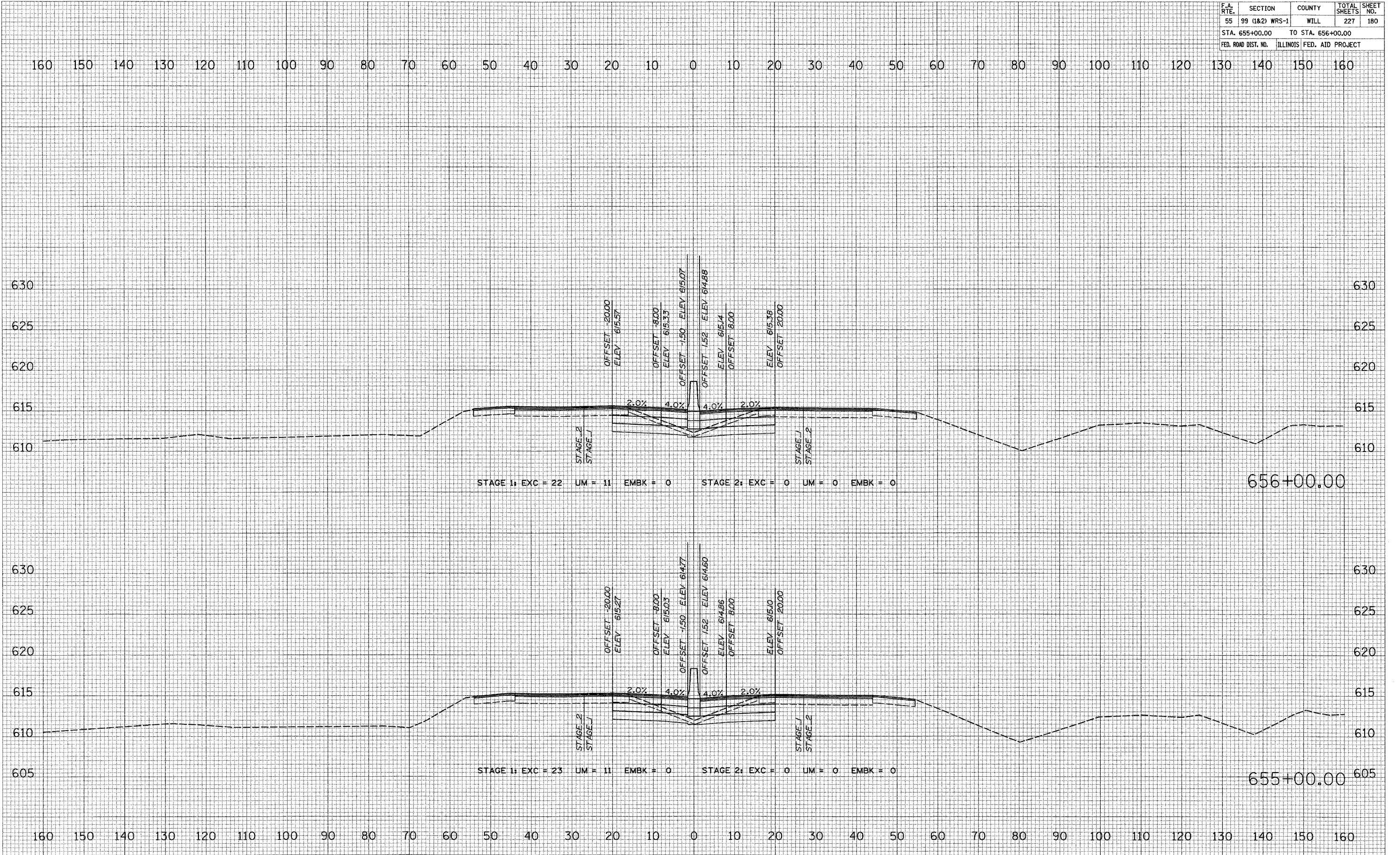

I-55 MAINLINE

CONTRACT NO. 62896				
F.A. RTE.	SECTION	COUNTY	TOTAL SHEETS	SHEET NO.
55	99 (I&2) WRS-1	WILL	227	181
STA. 657+00.00		TO STA. 659+00.00		
FED. ROAD DIST. NO.	ILLINOIS FED. AID PROJECT			

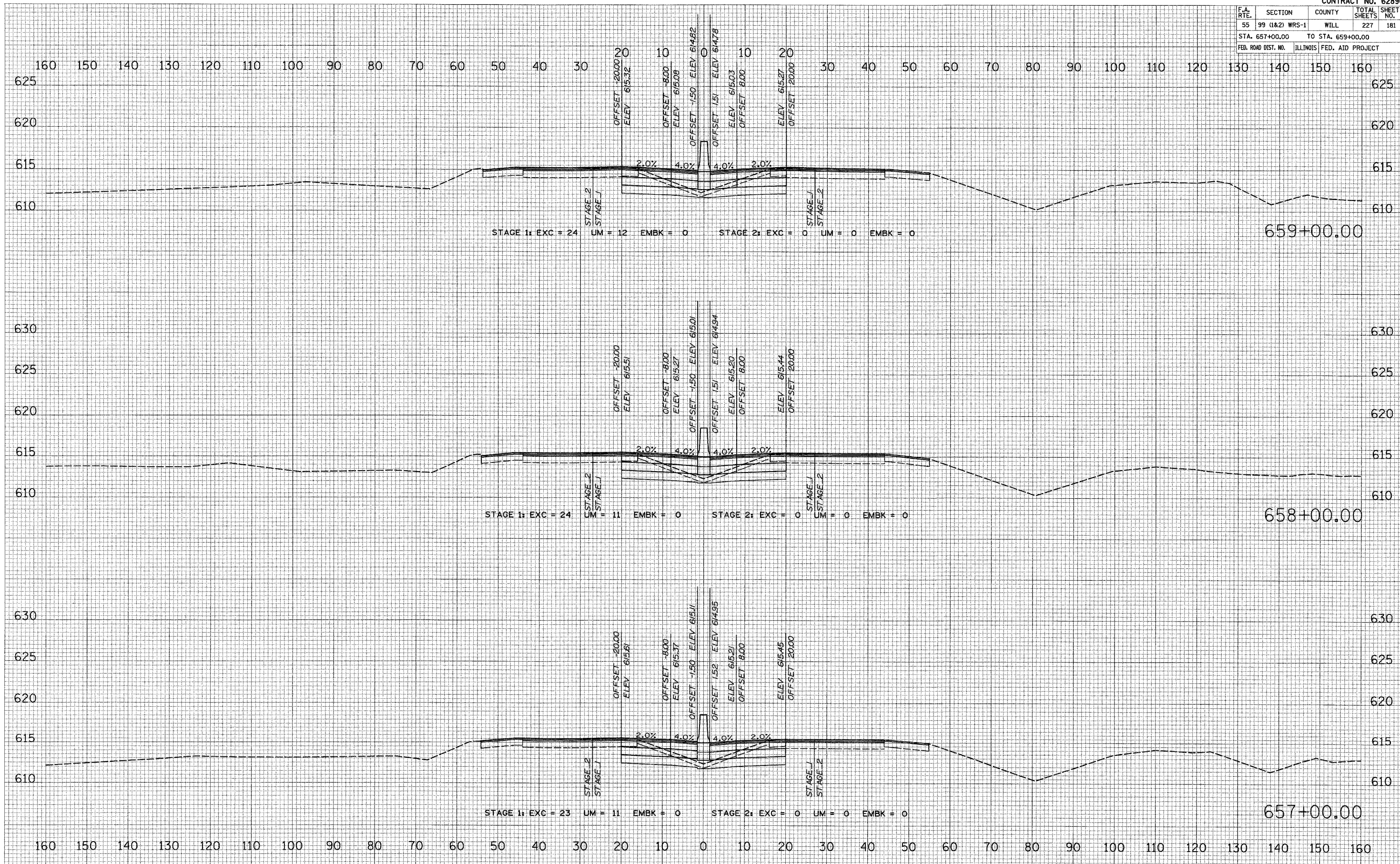

DATE: _____ BY: _____

ORIGINAL SURVEY PLOTTED _____

NOTE BOOK TEMPLATE _____

NO. _____ AREAS CHECKED _____

DATE: _____ BY: _____

ORIGINAL SURVEY PLOTTED _____

NOTE BOOK TEMPLATE _____

NO. _____ AREAS CHECKED _____

PLOT DATE = 2/15/2007

FILE NAME = I-55

USER NAME = AUSER

F.A. RTE.	SECTION	COUNTY	TOTAL SHEETS	SHEET NO.
55	99 (1&2) WRS-1	WILL	227	182
STA. 660+00.00 TO STA. 662+00.00				
FED. ROAD DIST. NO.		ILLINOIS FED. AID PROJECT		

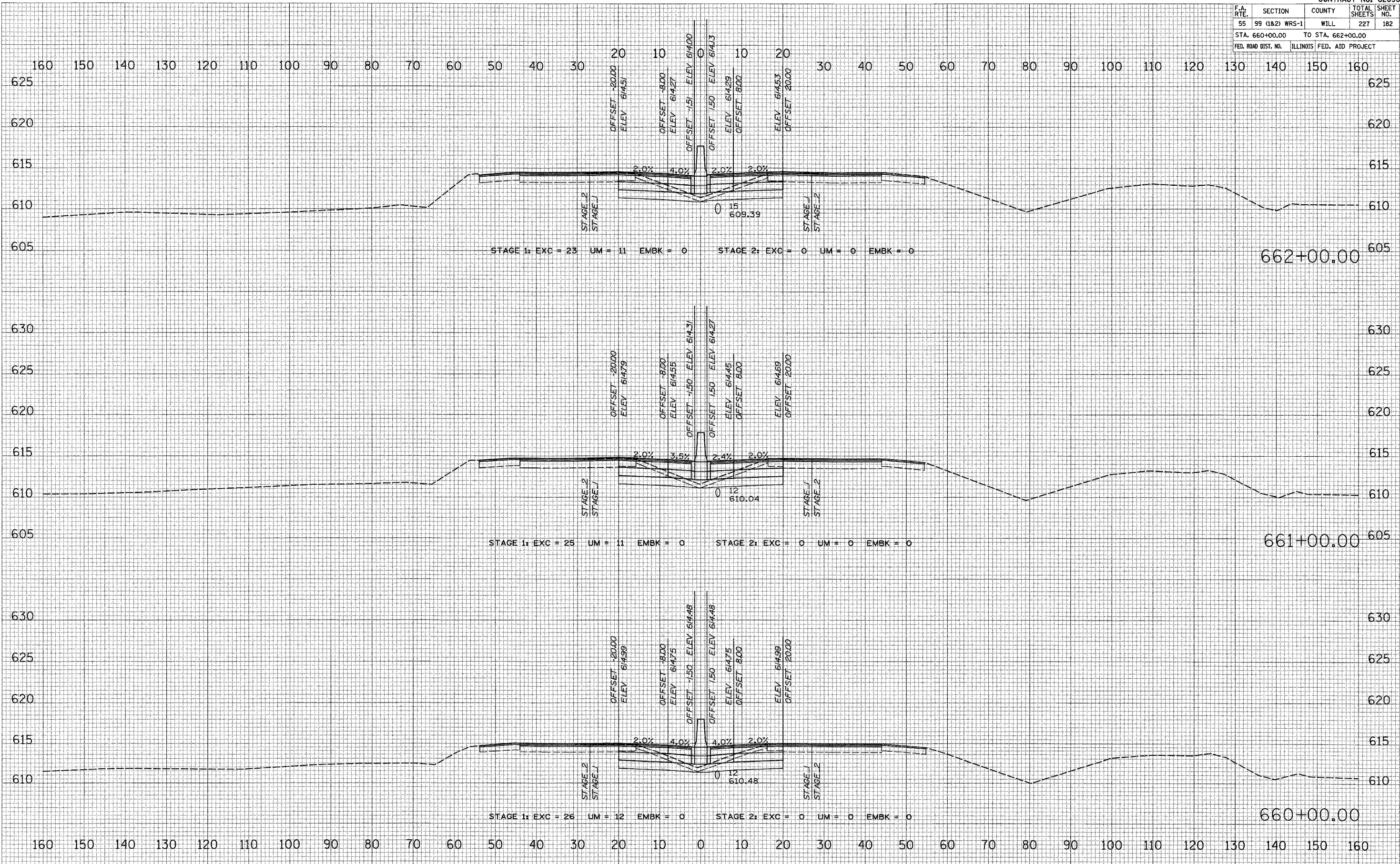

DATE _____
 BY _____
 SURVEYED _____
 PLOTTED _____
 NOTE BOOK _____
 AREAS CHECKED _____

DATE _____
 BY _____
 SURVEYED _____
 PLOTTED _____
 NOTE BOOK _____
 AREAS CHECKED _____

DATE = 2/10/97
 FILE NAME = 811L
 PLOT SCALE = 850L
 USER NAME = RUSSEB

CONTRACT NO. 62896				
F.A. RTE.	SECTION	COUNTY	TOTAL SHEETS	SHEET NO.
55	99 (1&2) WRS-1	WILL	227	183
STA. 663+00.00 TO STA. 664+00.00				
FED. ROAD DIST. NO. ILLINOIS FED. AID PROJECT				

DATE: _____
 BY: _____
 SURVEYED: _____
 PLOTTED: _____
 NOTE BOOK: _____
 AREAS CHECKED: _____

DATE: _____
 BY: _____
 SURVEYED: _____
 PLOTTED: _____
 NOTE BOOK: _____
 AREAS CHECKED: _____

DATE: 2/10/2007
 FILE NAME: #11
 PLOT SCALE: #10000
 USER NAME: #USER8

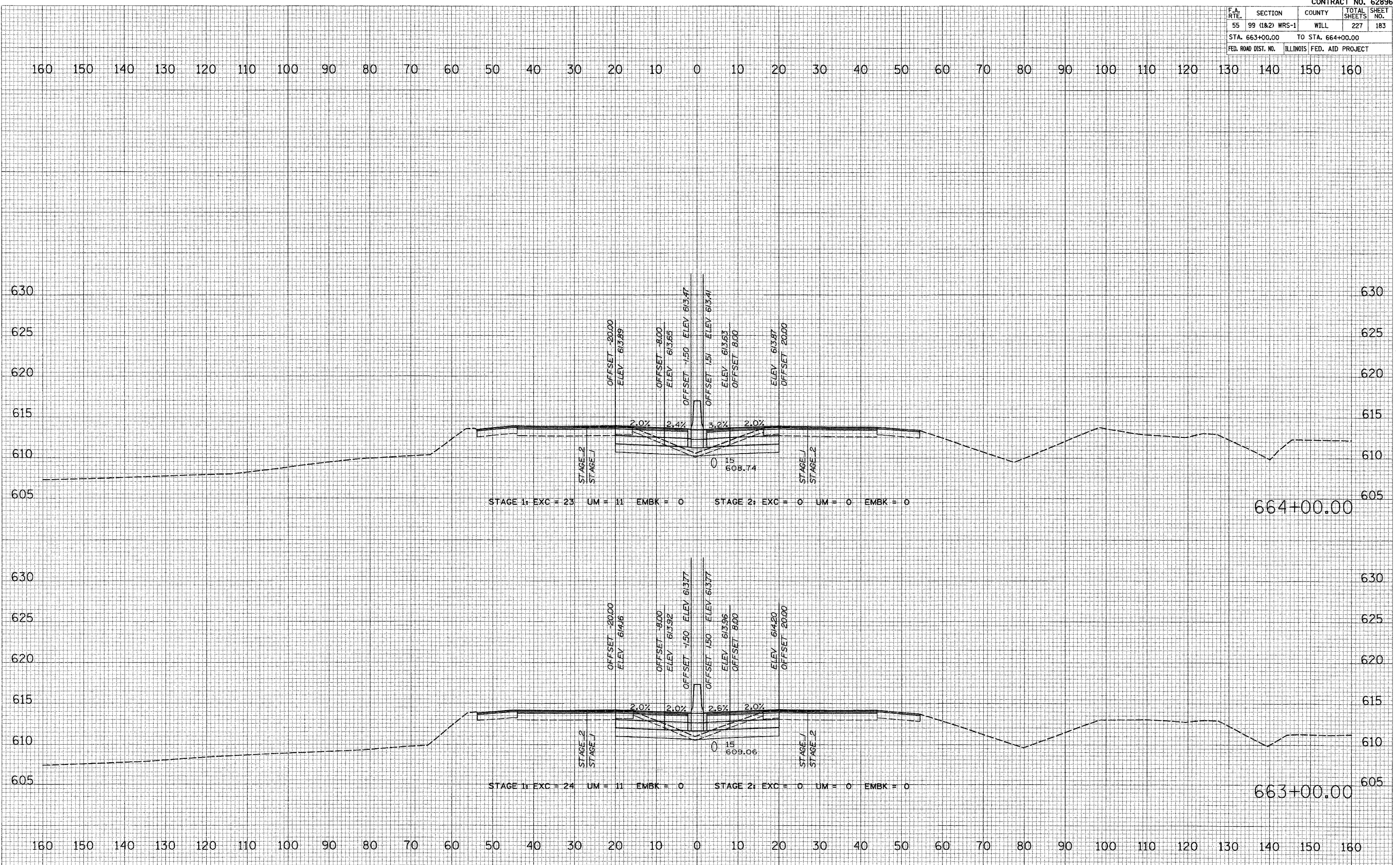

F.A. RTE.	SECTION	COUNTY	TOTAL SHEETS	SHEET NO.
55	99 (I&2) WRS-1	WILL	227	184
STA. 665+00.00 TO STA. 666+00.00				
FED. ROAD DIST. NO.			ILLINOIS FED. AID PROJECT	

DATE _____ BY _____
NO. _____
REVIEWED _____
SURVEY _____
NOTE BOOK _____
TEMPLATE _____
AREAS CHECKED _____

DATE _____ BY _____
NO. _____
REVIEWED _____
SURVEY _____
NOTE BOOK _____
TEMPLATE _____
AREAS CHECKED _____

PLOT DATE = 2/19/2007
FILE NAME = #FILE
PLOT SCALE = #SCALE
USER NAME = #USER

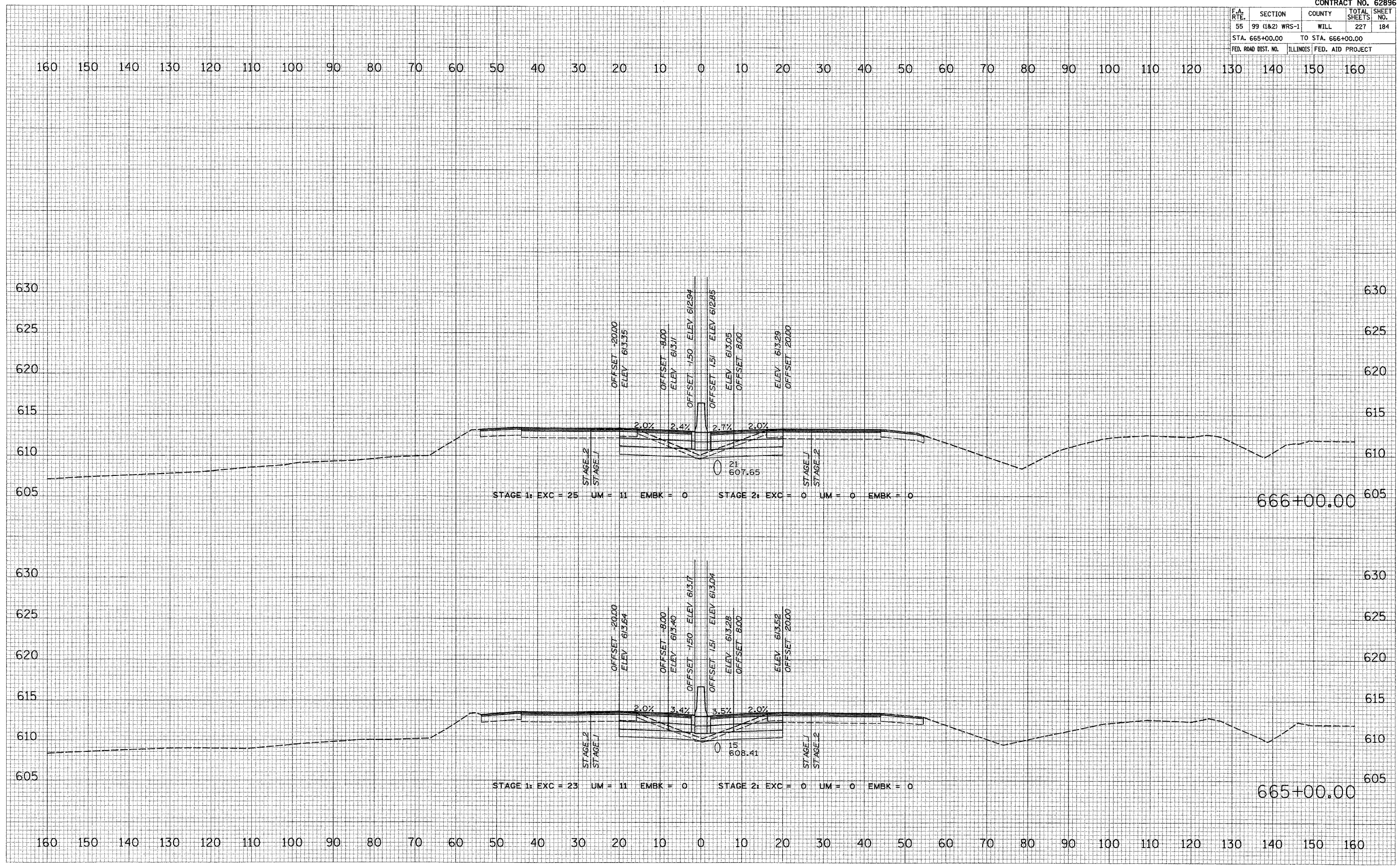

CONTRACT NO. 62896				
F.A. RTE.	SECTION	COUNTY	TOTAL SHEETS	SHEET NO.
55	99 (1&2) WRS-1	WILL	227	185
STA. 667+00.00 TO STA. 668+00.00				
FED. ROAD DIST. NO.	ILLINOIS	FED. AID PROJECT		

DATE	
BY	
FINAL SURVEY	
PLOTTED	
NOTE BOOK	
AREAS CHECKED	
NO.	

DATE	
BY	
ORIGINAL SURVEY	
PLOTTED	
NOTE BOOK	
AREAS CHECKED	
NO.	

DATE	
FILE NAME	
SCALE	
PLOT SCALE	
USER NAME	

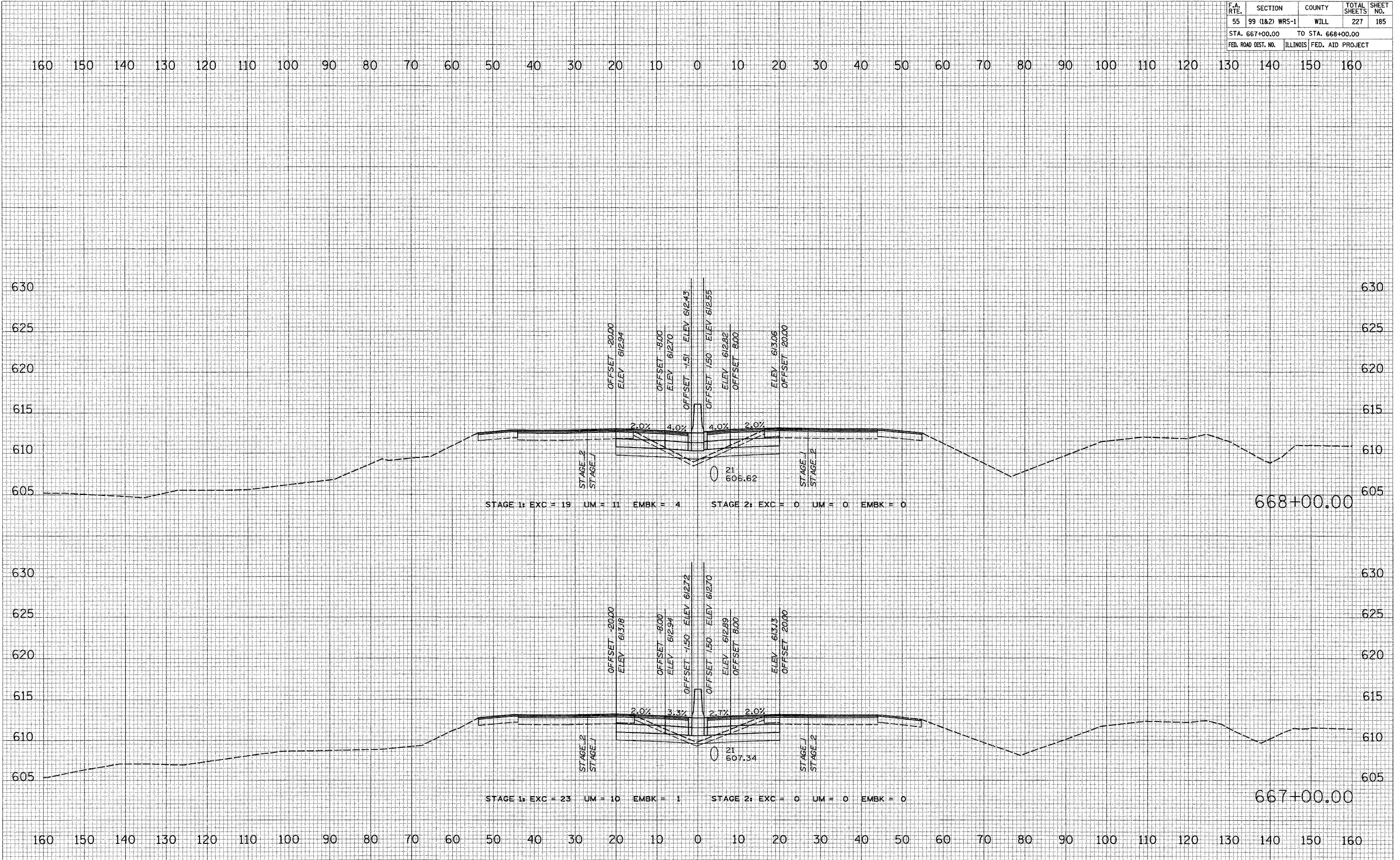

668+00.00

667+00.00

CONTRACT NO. 62896				
F.A. RTE.	SECTION	COUNTY	TOTAL SHEETS	SHEET NO.
55	99 (1&2) WRS-1	WILL	227	187
STA. 670+00.00		TO STA. 671+00.00		
FED. ROAD DIST. NO.	ILLINOIS	FED. AID PROJECT		

DATE _____ BY _____

FINAL SURVEY _____ SURVEYED _____

NOTE BOOK _____ PLOTTED _____

NO. _____ AREAS CHECKED _____

DATE _____ BY _____

ORIGINAL SURVEY _____ SURVEYED _____

NOTE BOOK _____ PLOTTED _____

NO. _____ AREAS CHECKED _____

DATE _____ BY _____

FILE NAME _____

PLOT SCALE _____

USER NAME _____

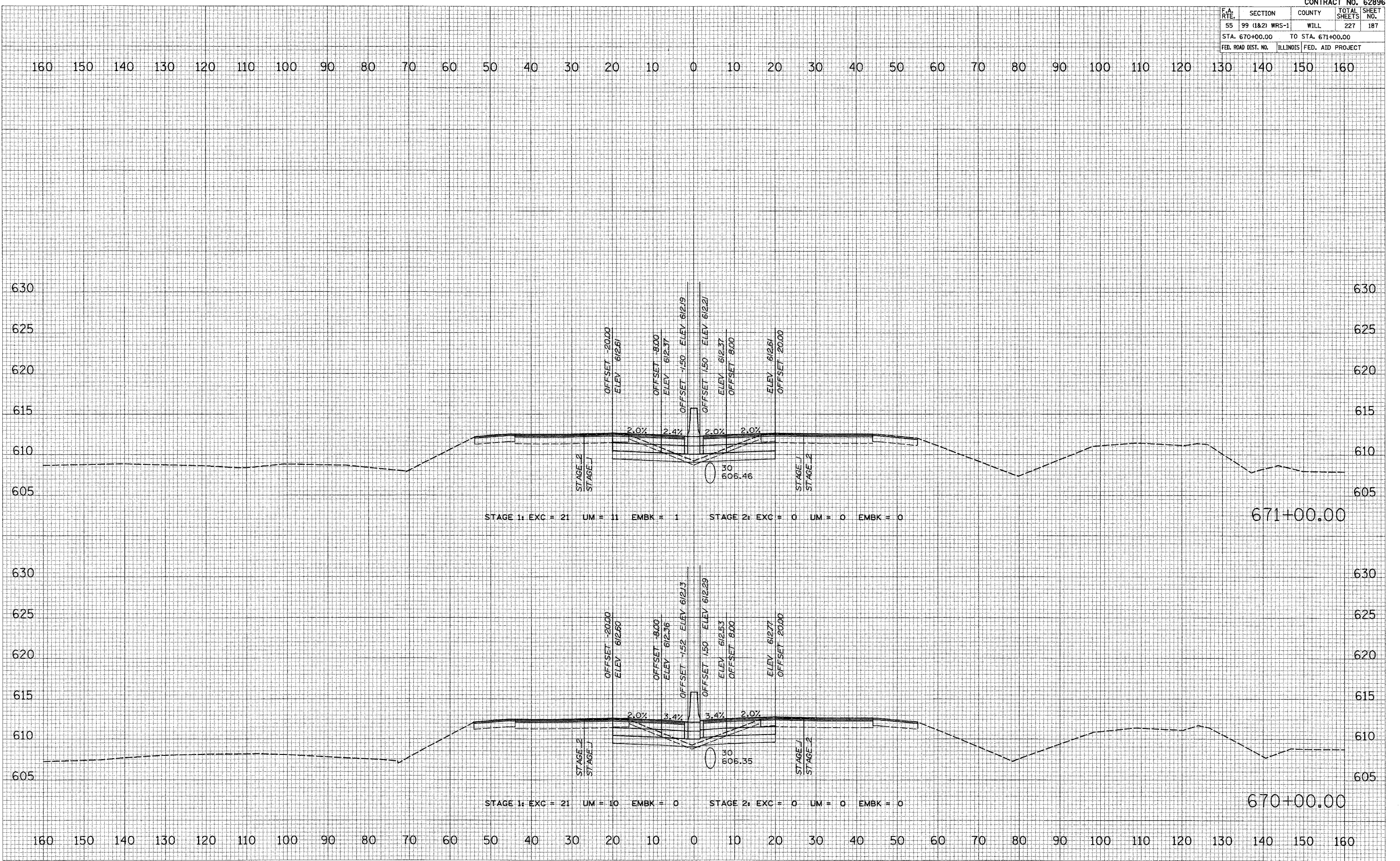

I-55 MAINLINE

CONTRACT NO. 62896				
F.A. RTE.	SECTION	COUNTY	TOTAL SHEETS	SHEET NO.
55	99 (1&2) WRS-1	WILL	227	188
STA. 672+00.00		TO STA. 673+00.00		
FED. ROAD DIST. NO.		ILLINOIS FED. AID PROJECT		

FINAL SURVEY	DATE
SURVEYED	
PLOTTED	
NOTE BOOK	
AREAS CHECKED	

ORIGINAL SURVEY	DATE
SURVEYED	
PLOTTED	
NOTE BOOK	
AREAS CHECKED	

PLOT DATE = 2/15/2007
 PLOT SCALE = 1"=40'
 USER NAME = MUSER

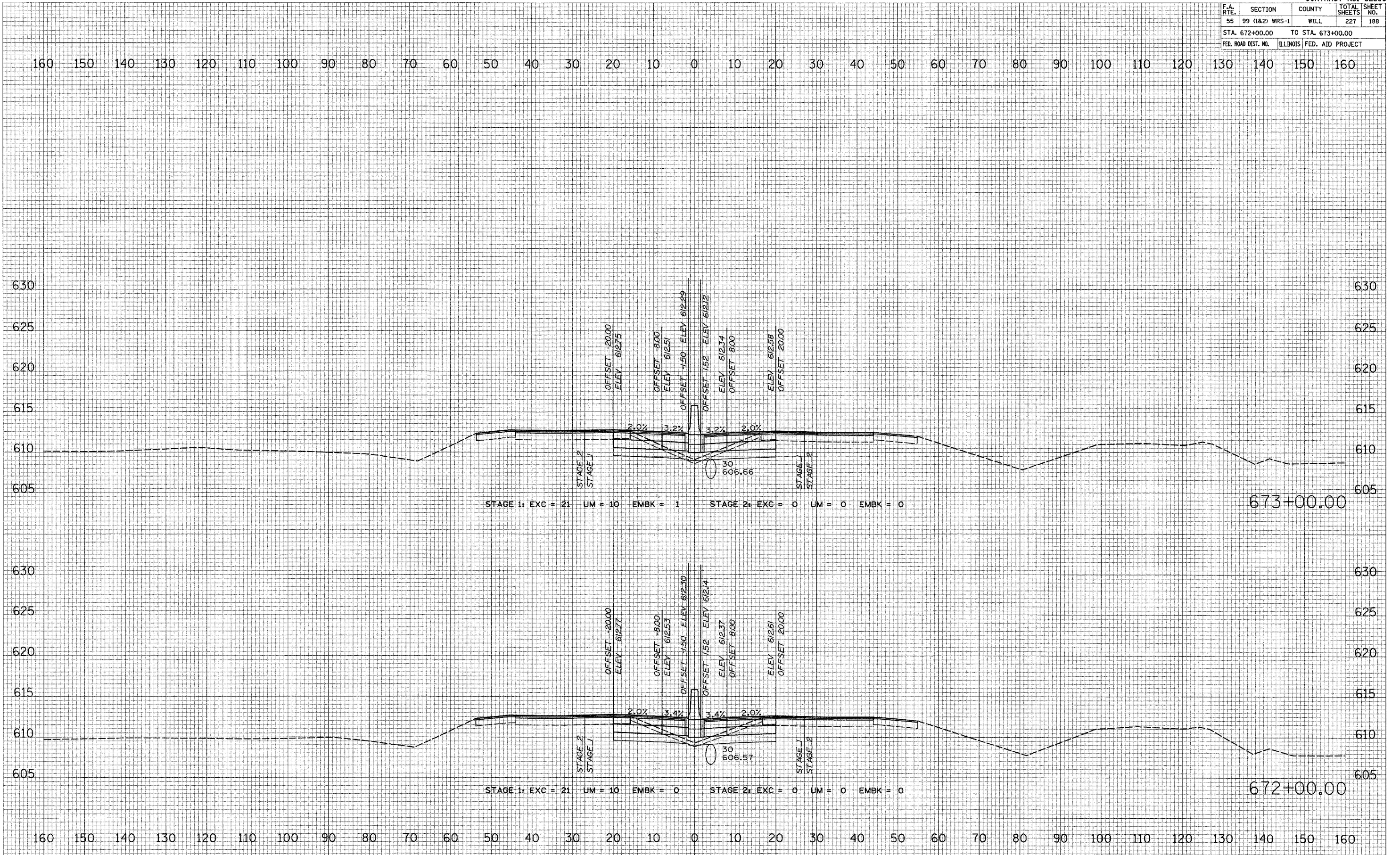

I-55 MAINLINE

CONTRACT NO. 62896				
F.A. RTE.	SECTION	COUNTY	TOTAL SHEETS	SHEET NO.
55	99 (1&2) WRS-1	WILL	227	190
STA. 676+00.00 TO STA. 677+00.00				
FED. ROAD DIST. NO.	ILLINOIS	FED. AID PROJECT		

FINAL SURVEY PLOTTED AREAS CHECKED

DATE _____ BY _____

NO. _____

ORIGINAL SURVEY PLOTTED AREAS CHECKED

DATE _____ BY _____

NO. _____

PLOT DATE = 2/19/97
 FILE NAME = #111
 PLOT SCALE = #1500#
 USER NAME = #1587#

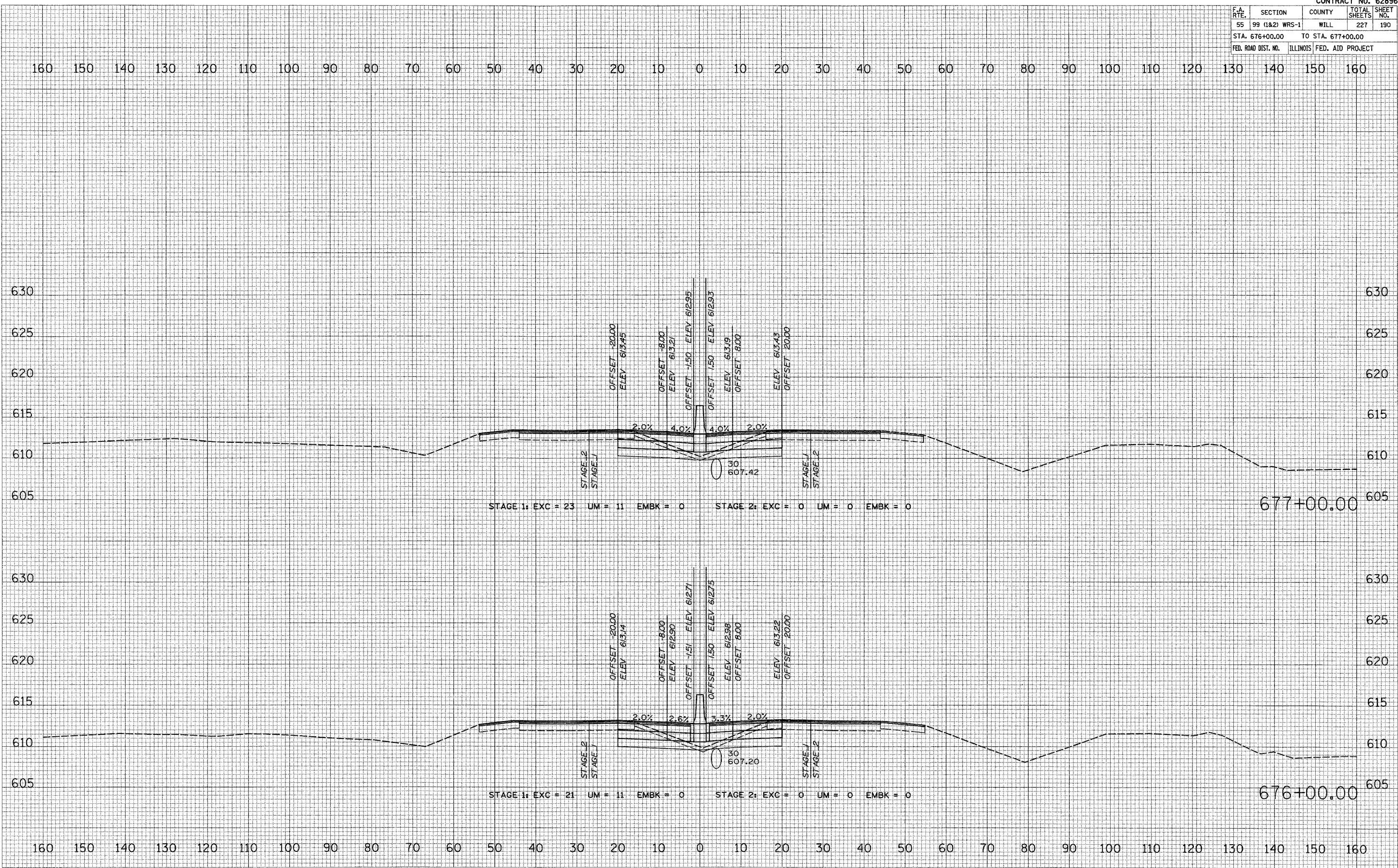

F.A. RTE.	SECTION	COUNTY	TOTAL SHEETS	SHEET NO.
55	99 (1&2) WRS-1	WILL	227	191
STA. 678+00.00		TO STA. 679+00.00		
FED. ROAD DIST. NO.		ILLINOIS FED. AID PROJECT		

DATE: _____ BY: _____

NO. _____

FINAL SURVEY PLOTTED TEMPLATE AREAS CHECKED

NO. _____

NO. _____

DATE: _____ BY: _____

NO. _____

ORIGINAL SURVEY PLOTTED TEMPLATE AREAS CHECKED

NO. _____

NO. _____

PLOT DATE = 2/15/2007
 FILE NAME = #FILE
 USER NAME = #USER

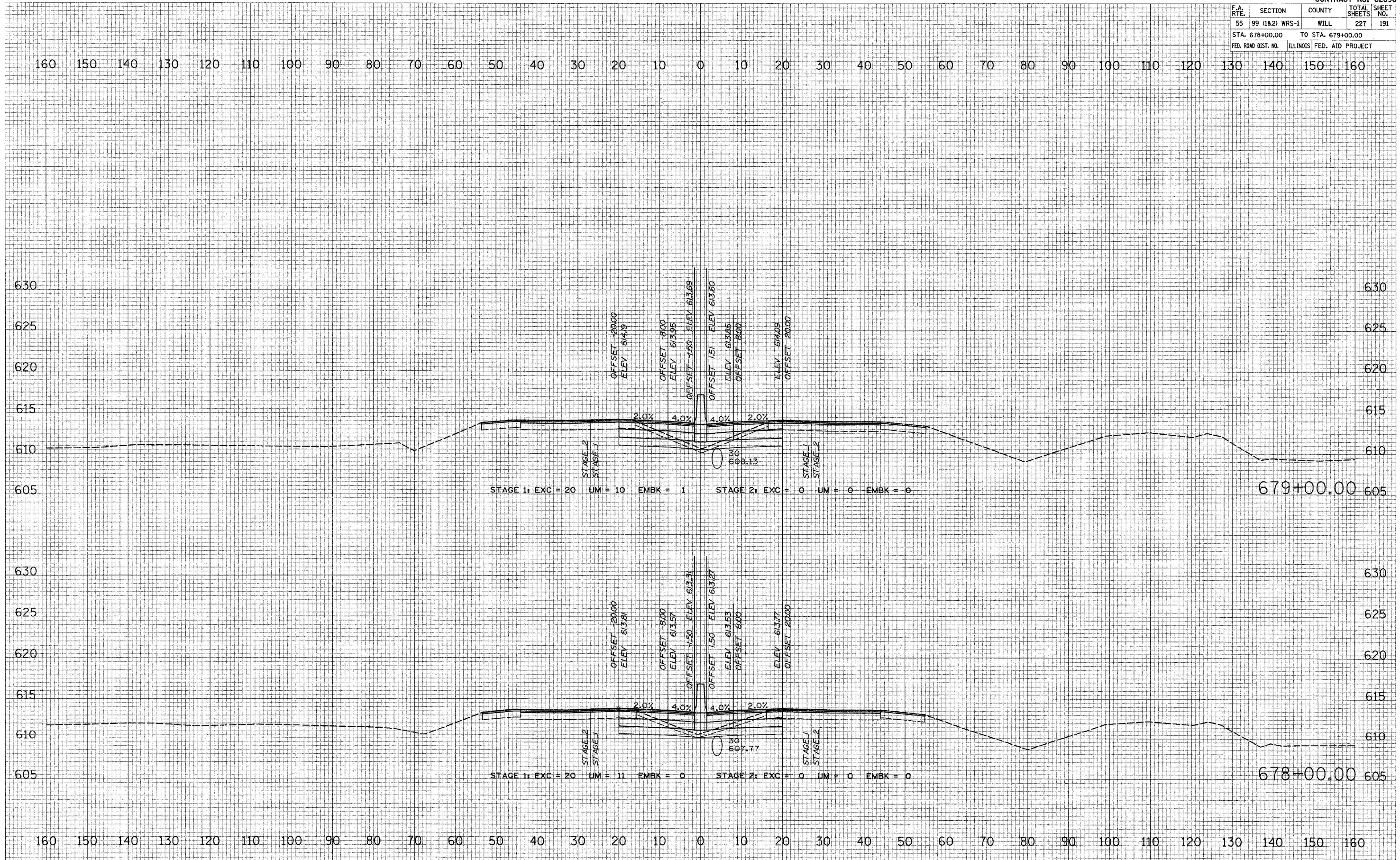

CONTRACT NO. 62896				
F.A. RTE.	SECTION	COUNTY	TOTAL SHEETS	SHEET NO.
55	99 (1&2) WRS-1	WILL	227	192
STA. 680+00.00 TO STA. 682+00.00				
FED. ROAD DIST. NO. ILLINOIS FED. AID PROJECT				

DATE: _____ BY: _____

FINAL SURVEY PLOTTED DATE: _____

NOTE BOOK NO. _____

AREAS CHECKED: _____

DATE: _____ BY: _____

ORIGINAL SURVEY PLOTTED DATE: _____

NOTE BOOK NO. _____

AREAS CHECKED: _____

PLT DATE = 2/19/2007
 FILE NAME = 6151
 PLOT SCALE = 80000
 USER NAME = RUSBY

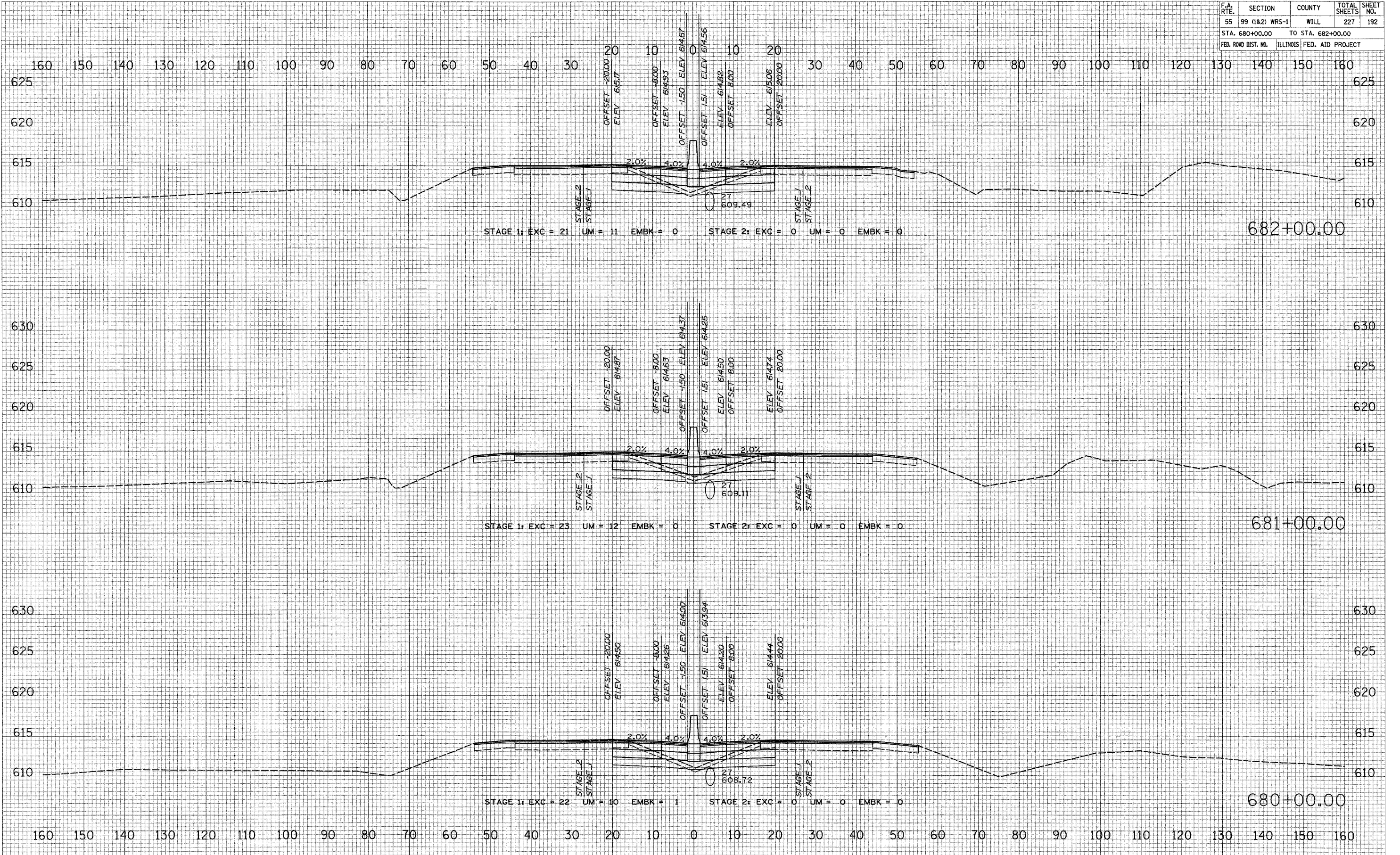

I-55 MAINLINE

CONTRACT NO. 62896				
F.A. RTE.	SECTION	COUNTY	TOTAL SHEETS	SHEET NO.
55	99 (1&2) WRS-1	WILL	227	193
STA. 683+00.00		TO STA. 684+00.00		
FED. ROAD DIST. NO.		ILLINOIS FED. AID PROJECT		

FINAL SURVEY SURVEYED BY: _____ DATE: _____
 NOTE BOOK NO. _____
 TEMPLATE AREAS CHECKED

ORIGINAL SURVEY SURVEYED BY: _____ DATE: _____
 NOTE BOOK NO. _____
 TEMPLATE AREAS CHECKED

PLOT DATE = 2/13/2007
 FILE NAME = #FILE#
 PLOT SCALE = #SCALE#
 USER NAME = #USER#

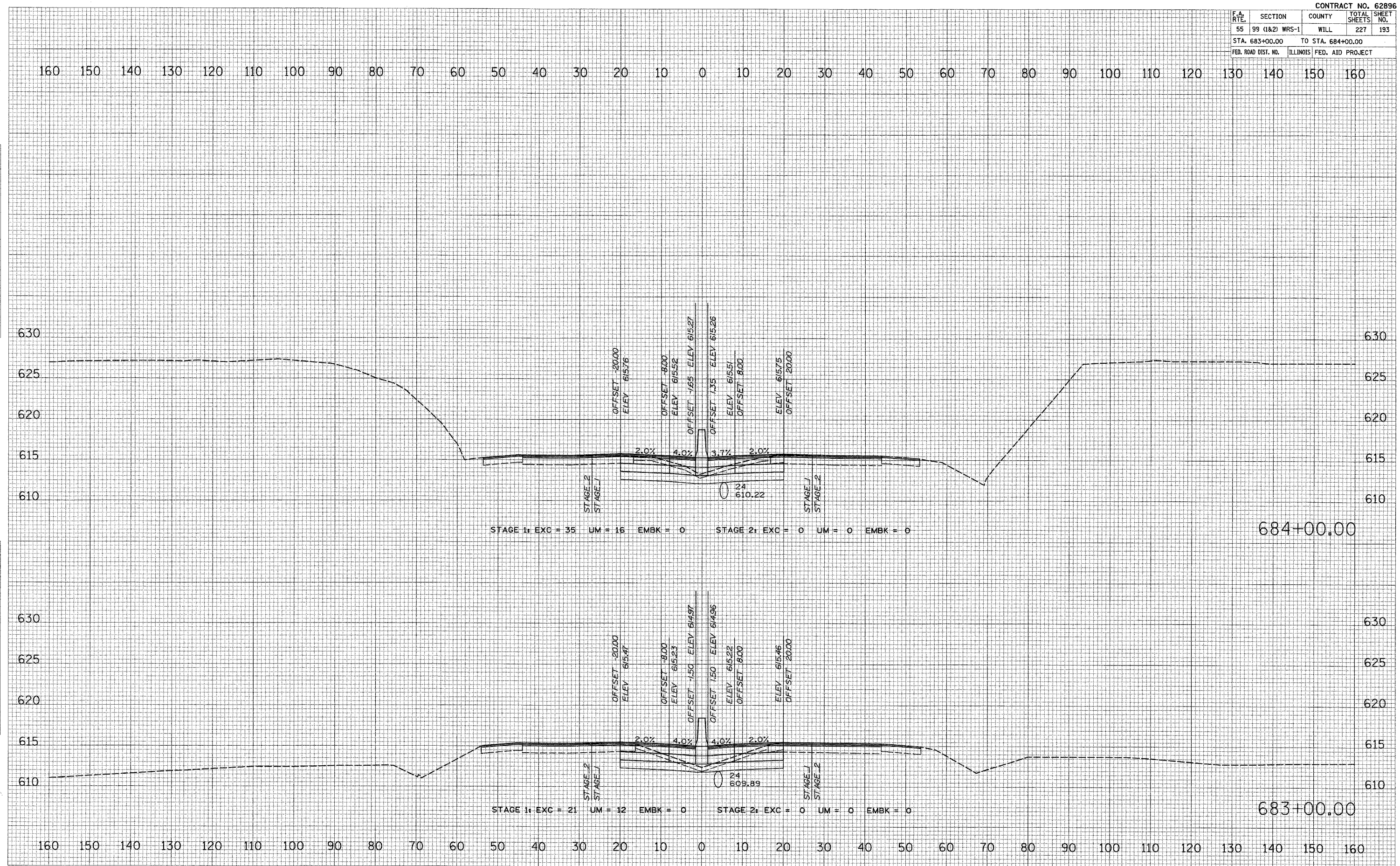

CONTRACT NO. 62896				
F.A. RTE.	SECTION	COUNTY	TOTAL SHEETS	SHEET NO.
55	99 (I&2) WRS-1	WILL	227	195
STA. 687+00.00 TO STA. 688+00.00				
FED. ROAD DIST. NO.		ILLINOIS	FED. AID PROJECT	

DATE: _____
 BY: _____
 SURVEYED: _____
 FINAL SURVEY: _____
 NOTE BOOK: _____
 TEMPLATE: _____
 AREAS CHECKED: _____

DATE: _____
 BY: _____
 SURVEYED: _____
 ORIGINAL SURVEY: _____
 NOTE BOOK: _____
 TEMPLATE: _____
 AREAS CHECKED: _____

PLOT DATE = 2/19/2007
 FILE NAME = #FILL
 PLOT SCALE = #SCALE
 USER NAME = #USER

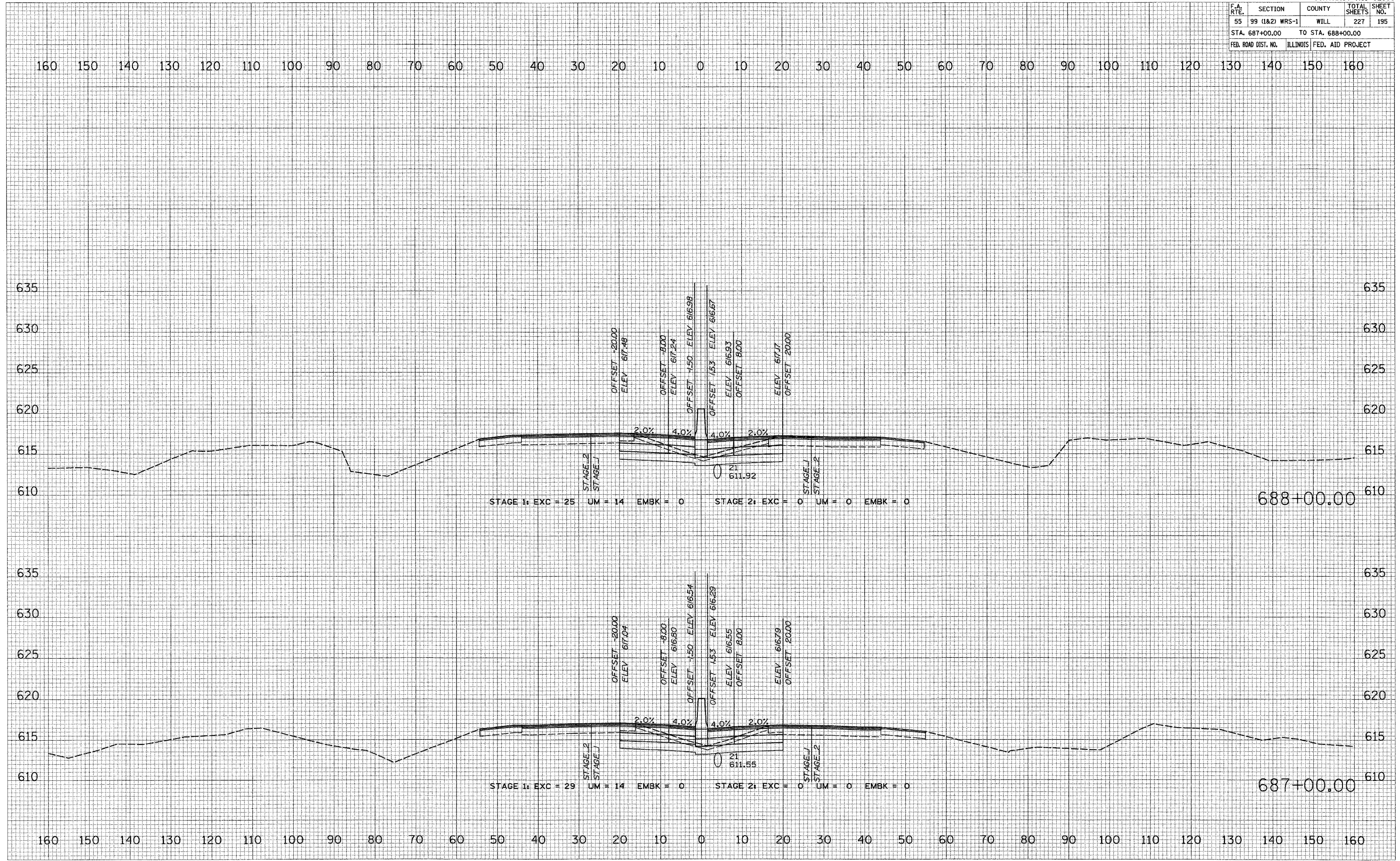

I-55 MAINLINE

CONTRACT NO. 62896				
F.A. RTE.	SECTION	COUNTY	TOTAL SHEETS	SHEET NO.
55	99 (I&2) WRS-1	WILL	227	196
STA. 689+00.00		TO STA. 690+00.00		
FED. ROAD DIST. NO. ILLINOIS FED. AID PROJECT				

DATE: _____ BY: _____

FINAL SURVEY: _____
 SURVEY PLOTTED: _____
 NOTE BOOK: _____
 AREAS CHECKED: _____

DATE: _____ BY: _____

ORIGINAL SURVEY: _____
 SURVEY PLOTTED: _____
 NOTE BOOK: _____
 AREAS CHECKED: _____

PLOT DATE = 2/19/2007
 PLOT SCALE = 1"=40'
 USER NAME = USER

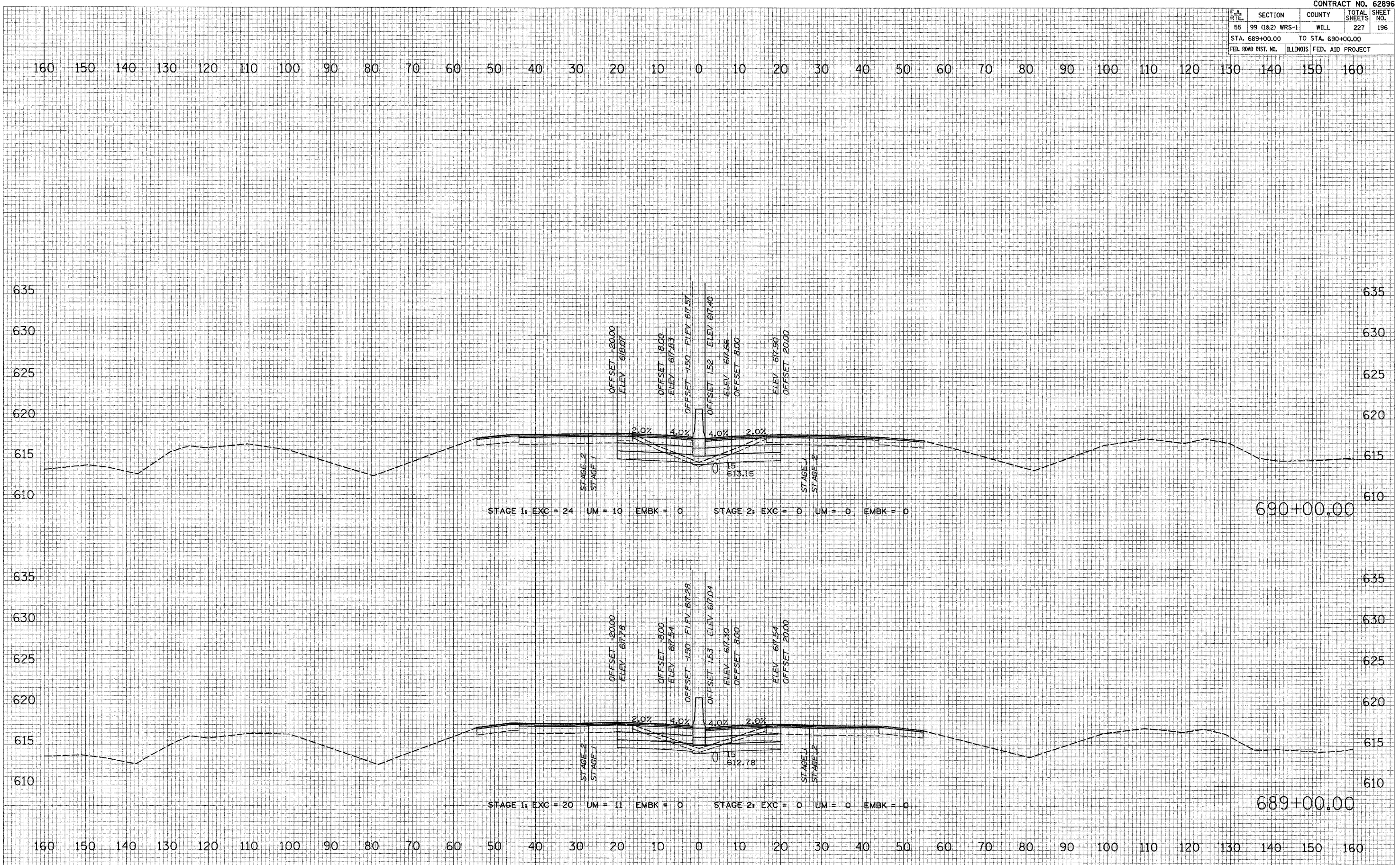

CONTRACT NO. 62896				
F.A. RTE.	SECTION	COUNTY	TOTAL SHEETS	SHEET NO.
55	99 (I&2) WRS-1	WILL	227	197
STA. 691+00.00 TO STA. 692+00.00				
FED. ROAD DIST. NO.		ILLINOIS	FED. AID PROJECT	

FINAL SURVEY PLOTTED PLATE AREAS CHECKED
 SURVEY PLOTTED PLATE AREAS CHECKED
 NOTE BOOK NO.

ORIGINAL SURVEY PLOTTED PLATE AREAS CHECKED
 SURVEY PLOTTED PLATE AREAS CHECKED
 NOTE BOOK NO.

PLT DATE = 8/15/07
 FILE NAME = 691
 PLOT SCALE = 1"=40'
 USER NAME = MUSER

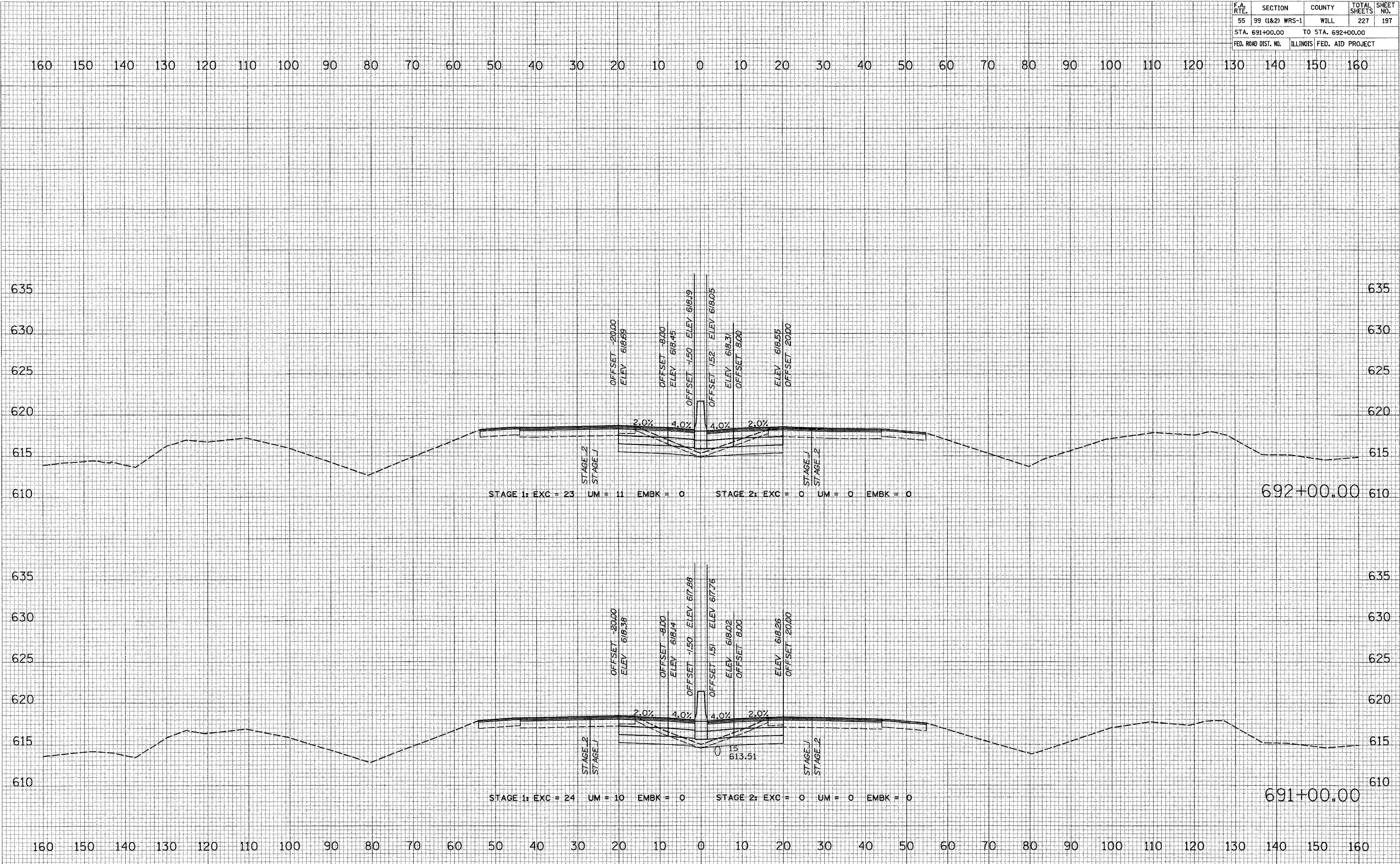

CONTRACT NO. 62896				
F.A. RTE.	SECTION	COUNTY	TOTAL SHEETS	SHEET NO.
55	99 (I&2) WRS-1	WILL	227	198
STA. 693+00.00		TO STA. 694+00.00		
FED. ROAD DIST. NO.		ILLINOIS FED. AID PROJECT		

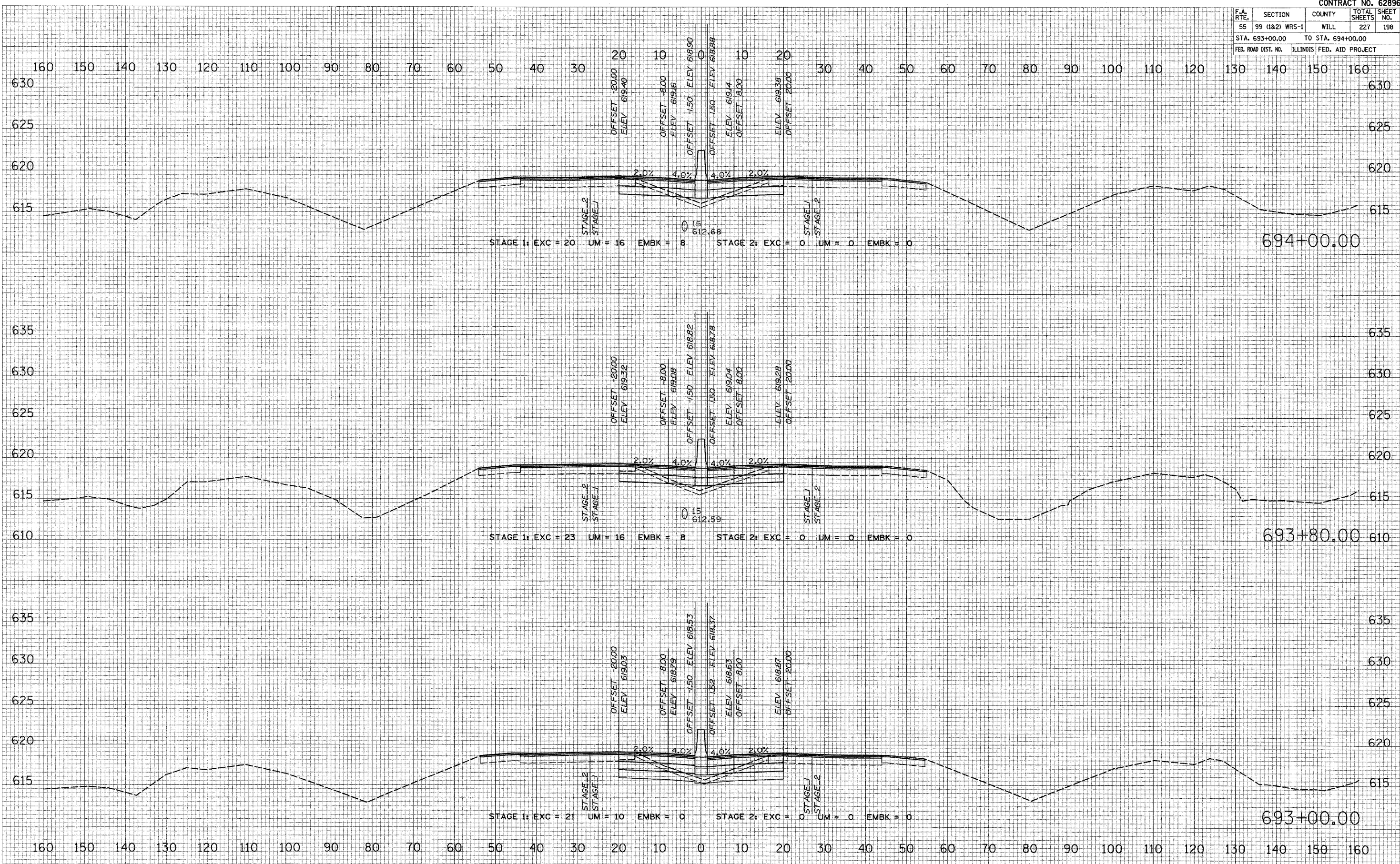

DATE _____
 BY _____
 SURVEYED _____
 PLOTTED _____
 NOTE BOOK _____
 AREAS CHECKED _____
 NO. _____

DATE _____
 BY _____
 ORIGINAL SURVEY _____
 PLOTTED _____
 NOTE BOOK _____
 AREAS CHECKED _____
 NO. _____

DATE _____
 FILE NAME _____
 PLOT SCALE _____
 USER NAME _____

CONTRACT NO. 62896				
F.A. RTE.	SECTION	COUNTY	TOTAL SHEETS	SHEET NO.
55	99 (1&2) WRS-1	WILL	227	199
STA. 695+00.00 TO STA. 696+00.00				
FED. ROAD DIST. NO.		ILLINOIS	FED. AID PROJECT	

DATE _____
 BY _____
 SURVEYED _____
 PLOTTED _____
 NOTE BOOK _____
 AREAS CHECKED _____

DATE _____
 BY _____
 SURVEYED _____
 PLOTTED _____
 NOTE BOOK _____
 AREAS CHECKED _____

DATE = 2/10/2007
 FILE NAME = #SCALE
 PLOT SCALE = #USER#
 USER NAME = #USER#

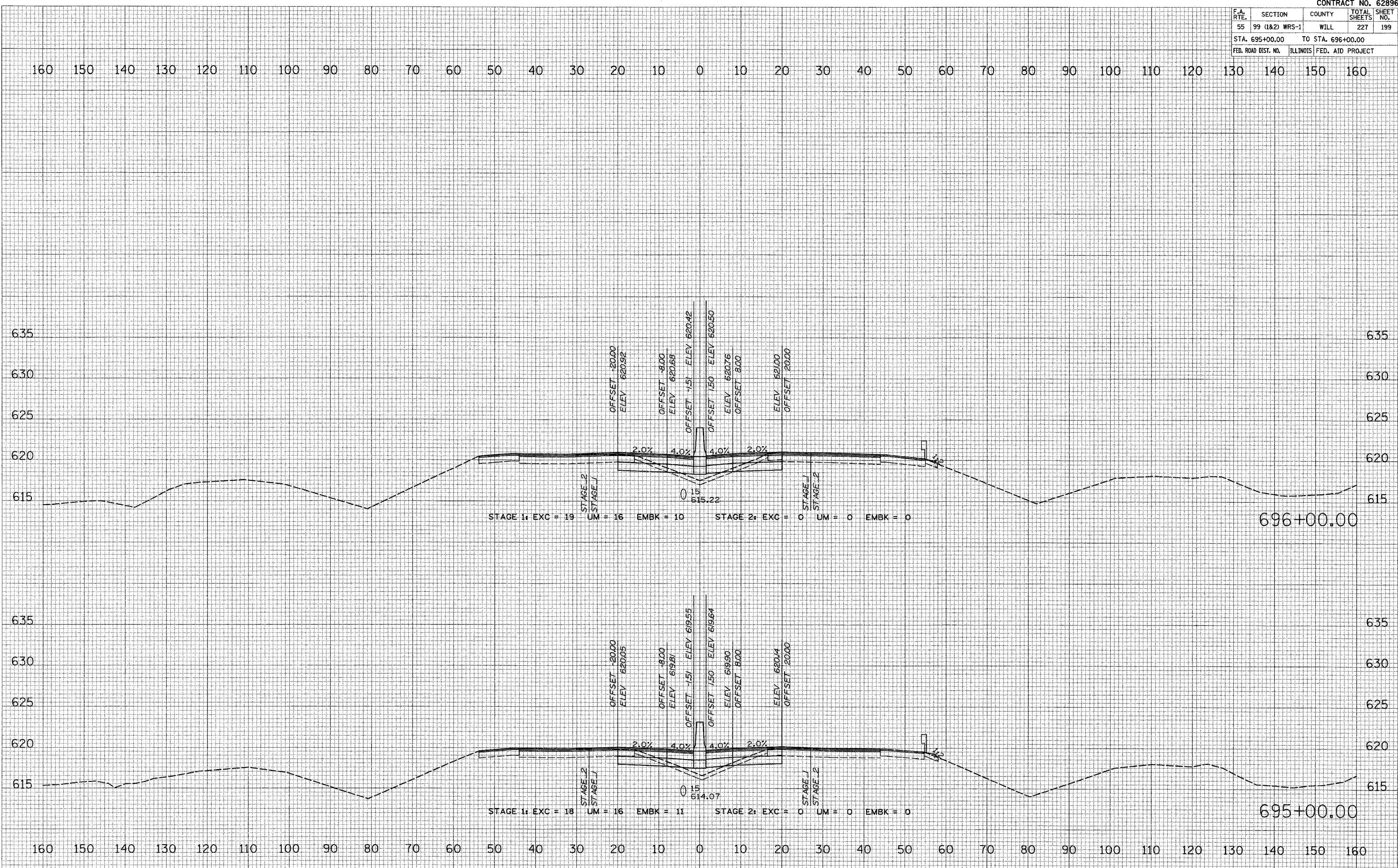

I-55 MAINLINE

F.A. RTE.	SECTION	COUNTY	TOTAL SHEETS	SHEET NO.
55	99 (1&2) WRS-1	WILL	227	200
STA. 697+00.00		TO STA. 698+00.00		
FED. ROAD DIST. NO.		ILLINOIS FED. AID PROJECT		

DATE _____
 BY _____
 SURVEYED _____
 PLOTTED _____
 FINISH DATE _____
 SURVEY NO. _____
 NOTE BOOK NO. _____
 AREAS CHECKED _____

DATE _____
 BY _____
 SURVEYED _____
 PLOTTED _____
 FINISH DATE _____
 SURVEY NO. _____
 NOTE BOOK NO. _____
 AREAS CHECKED _____

DATE _____
 BY _____
 SURVEYED _____
 PLOTTED _____
 FINISH DATE _____
 SURVEY NO. _____
 NOTE BOOK NO. _____
 AREAS CHECKED _____

