

F.A.P. RTE.	SECTION	COUNTY	TOTAL SHEETS	SHEET NO.
317	(44,45)RS-5, (45-1)RS-7 (45-1)RB, RB-2, BR1	PEORIA	82	30
FED. ROAD DIST. NO.	ILLINOIS	FED. AID PROJECT		

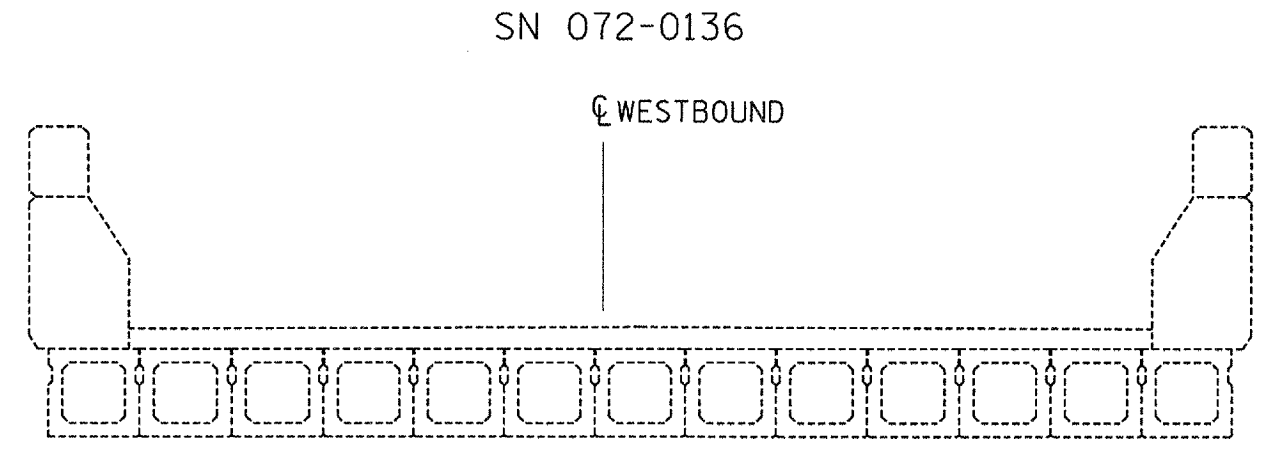
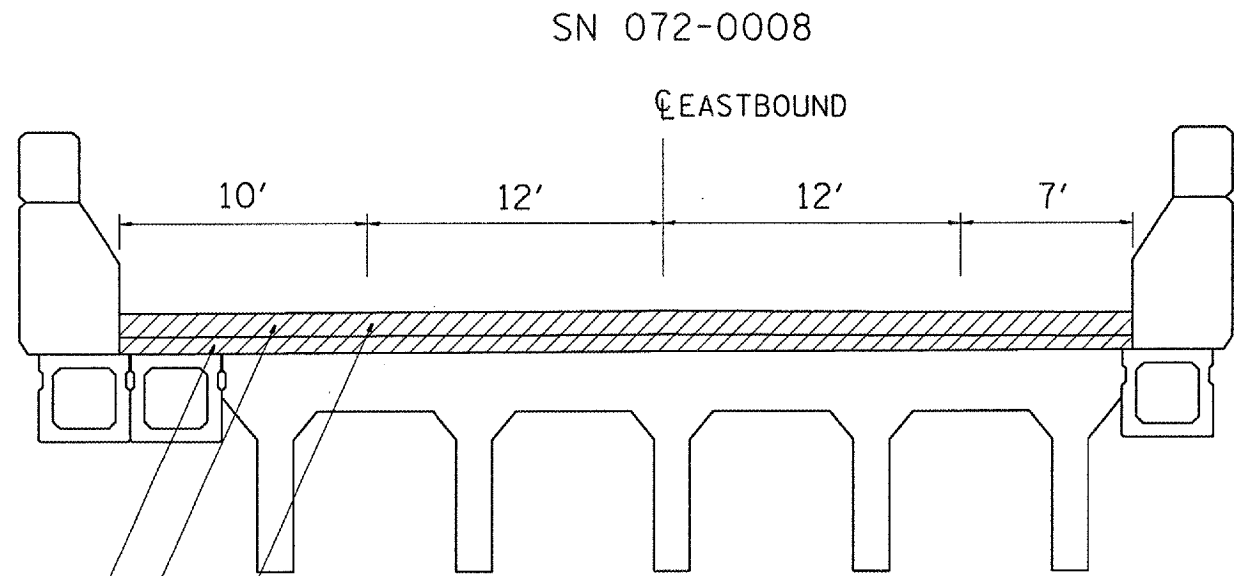

SUPERSTRUCTURE TO BE REPLACED
REFER TO STRUCTURAL PLANS FOR PROPOSED IMPROVEMENT

PROPOSED 1 1/2" POLYMERIZED HMA
SURFACE COURSE, MIX D, N50

PROPOSED 1 1/2" WEARING SURFACE REMOVAL

EXISTING WATERPROOFING MEMBRANE
SYSTEM (WMS) - (TO BE REMOVED AND REPLACED)

TYPICAL SECTION 7
(U.S. 24)

LITTLE LAMARSH CREEK STRUCTURES
(SN 072-0008 & SN 072-0136)

(LOOKING WESTBOUND)

STA. 496+26 TO STA. 497+51

LEGEND

- Ⓐ EXISTING 2 1/2 " AND VARIABLE HMA
- Ⓑ EXISTING P.C.C. PAVEMENT 10".
- Ⓒ EXISTING GUARDRAIL (MEDIAN).
- Ⓓ EXISTING HMA SHOULDER
- Ⓔ EXISTING AGGREGATE SHOULDER
- Ⓕ EXISTING CONCRETE MEDIAN SURF. - 4"
- Ⓖ EXISTING COMB. CONC. CURB & GUTTER

- Ⓚ PROPOSED AGGREGATE SHOULDER TYPE B
- Ⓛ PROPOSED 1/2 " HMA SURFACE REMOVAL (HATCHED AREA)
- Ⓜ PROPOSED 2 1/4 " HMA SURFACE REMOVAL (HATCHED AREA)
- Ⓝ PROPOSED 3/4" LEVELING BINDER MACHINE METHOD
- Ⓞ PROPOSED 1 1/2 " HMA SURFACE COURSE
- Ⓟ PROPOSED 2 1/4 " HMA SHOULDER
- Ⓠ PROPOSED 1 3/4 " HMA SHOULDER

ILLINOIS DEPARTMENT OF TRANSPORTATION

PROPOSED TYPICAL
SECTIONS - US 24

DATE: 02-10-06

DRAWN BY: DBB

CHECKED BY: CEM