

F.A.P. RTE.	SECTION	COUNTY	TOTAL SHEETS	SHEET NO.
717	109 (RS-3)	LOGAN	31	27
STA. 57+64.50		TO STA. 631+30.00		
FED. ROAD DIST. NO. 6		ILLINOIS FED. AID PROJECT		

CONTRACT NO. 72825

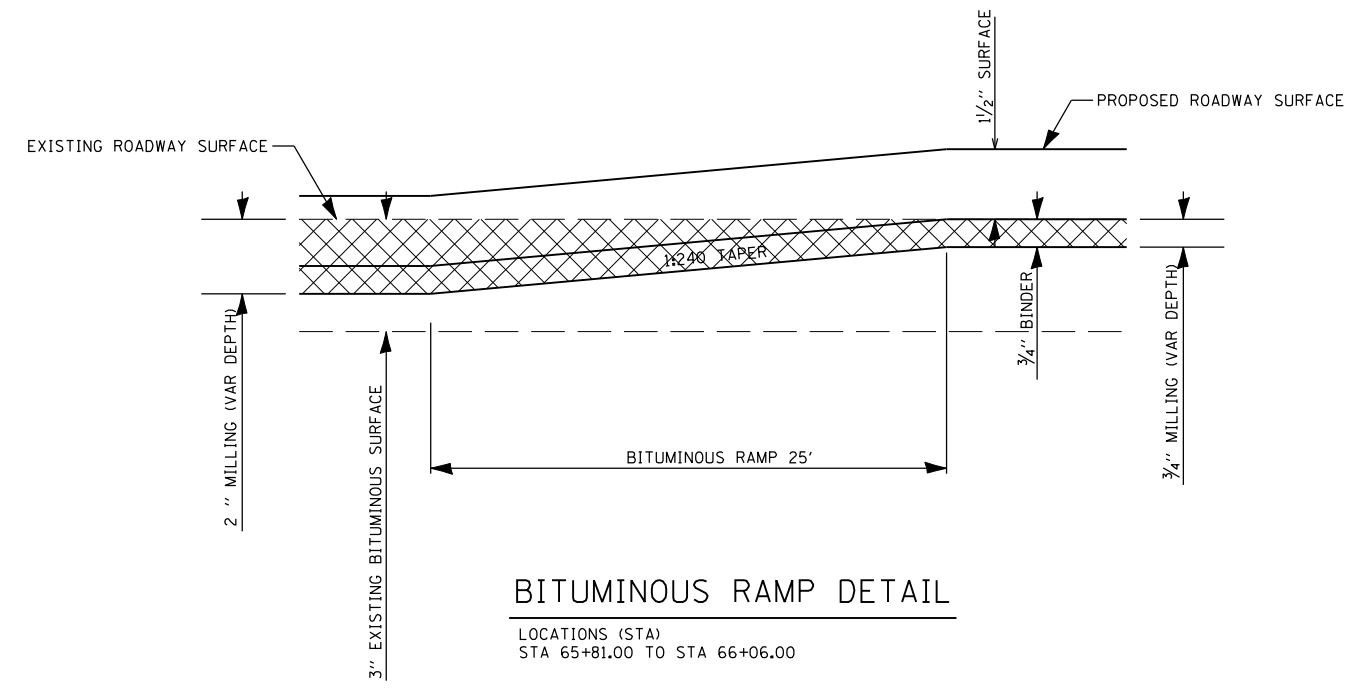
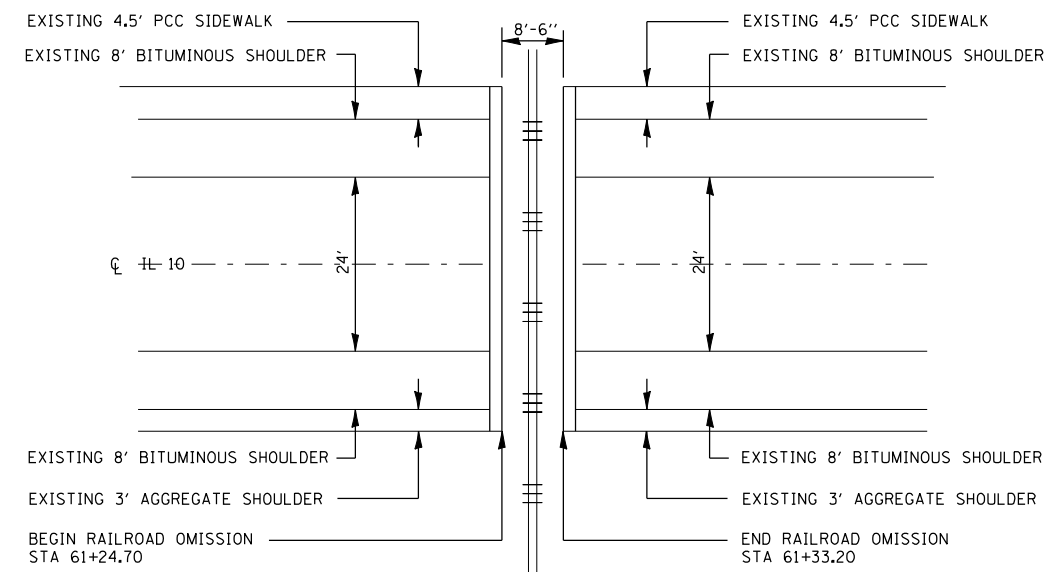
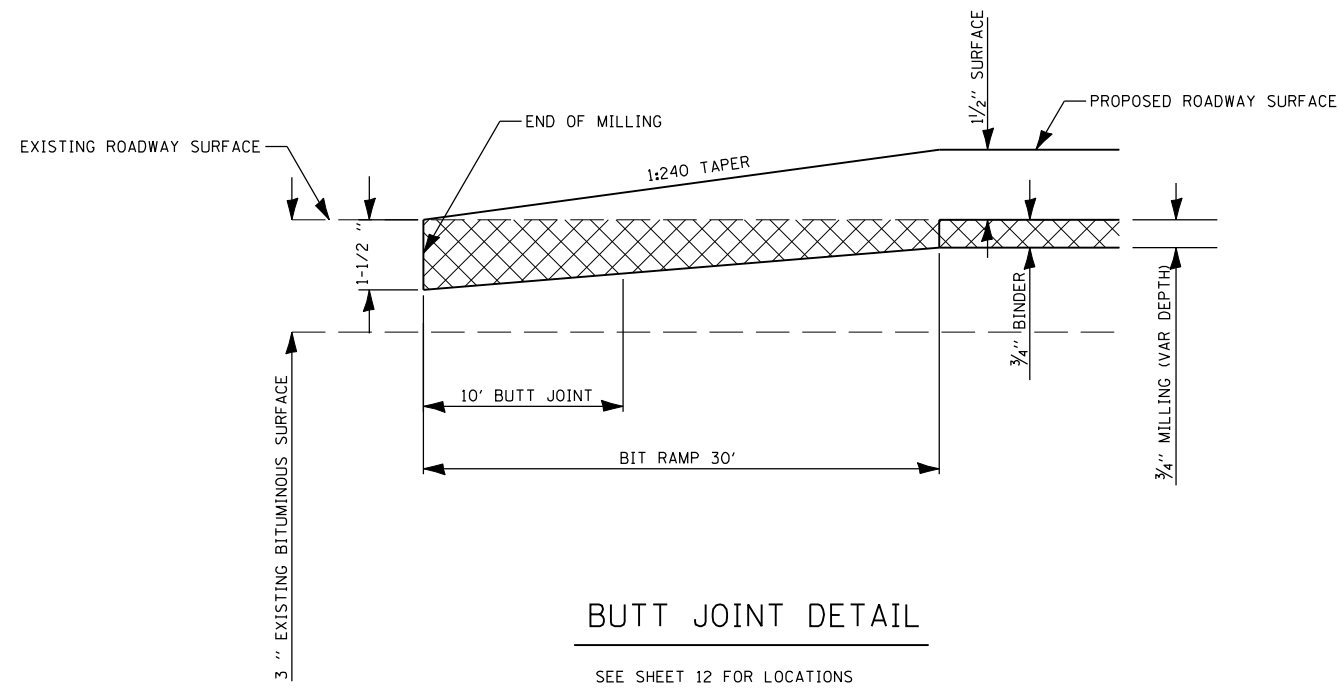

G:\PROG\CIVIL\G13303.74\DCN\BUTT.JNT

REVISIONS	
NAME	DATE

ILLINOIS DEPARTMENT OF TRANSPORTATION
DETAILS
FAP ROUTE 717 (IL 10)
SECTION 109 (RS-3)
LOGAN COUNTY
SCALE: NONE
DATE: AUG 2004
DRAWN BY: MLH
CHECKED BY: LDB