

ROUTE NO.	SECTION	COUNTY	TOTAL SHEETS	SHEET NO.
FAU 1488		COOK	24	12
ILLINOIS PROJECT	M-8003 (571)			
VILLAGE SECTION	05-00016-00-RS			
CONTRACT NO.	83884			

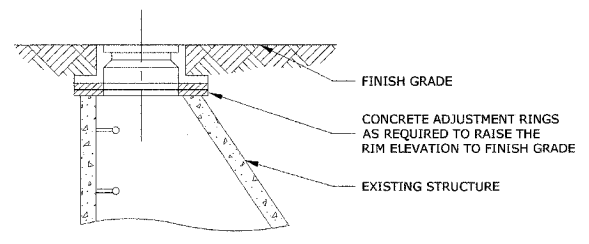

RIM ADJUSTMENT DETAIL

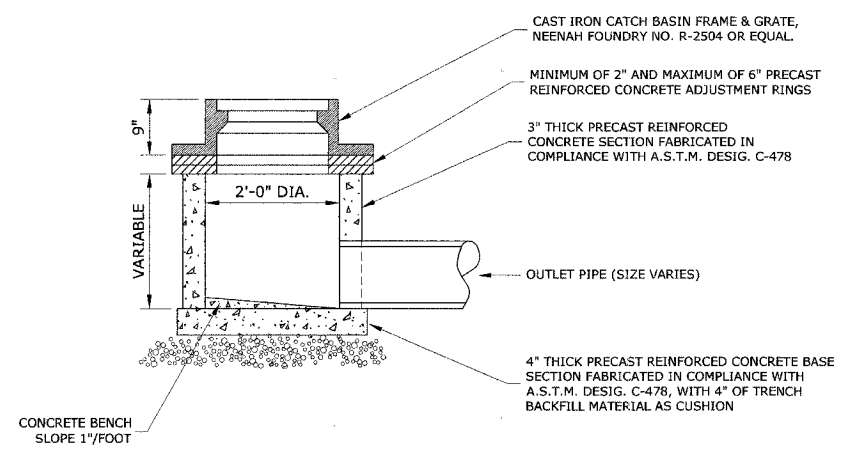

INLET, TYPE A

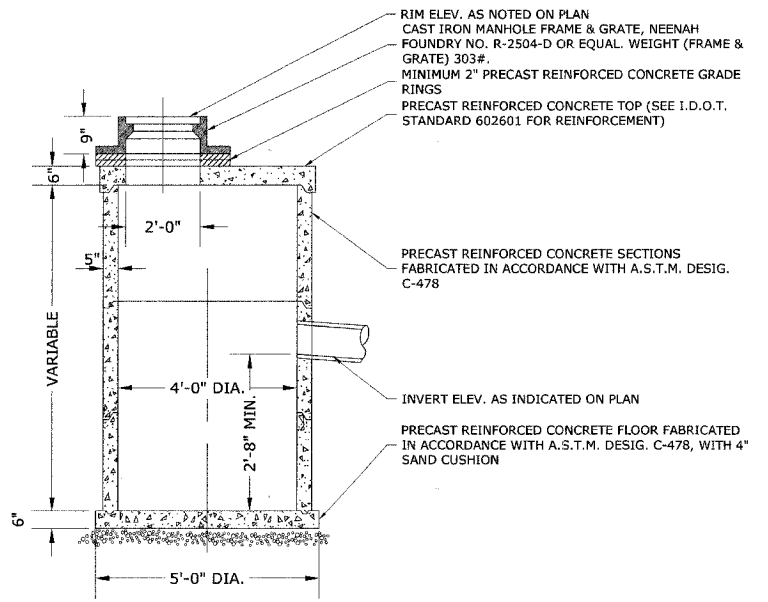

RESTRICTED DEPTH CATCH BASIN

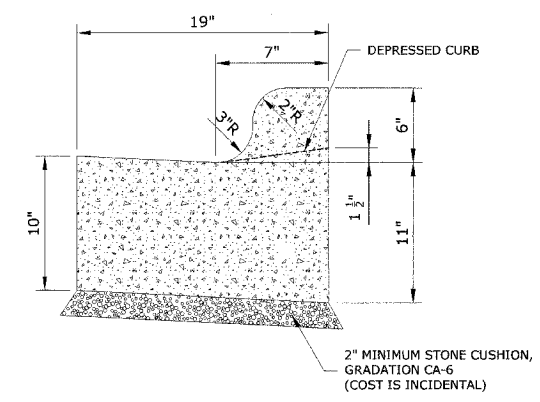

COMBINATION CONCRETE CURB & GUTTER TYPE B-6.12 (MODIFIED)

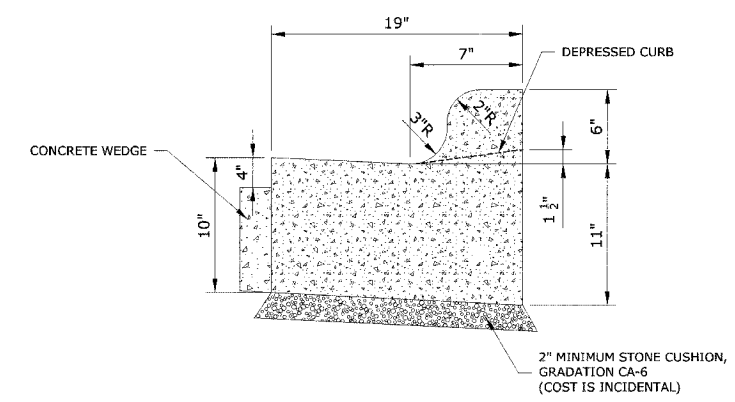

COMBINATION CONCRETE CURB & GUTTER TYPE B-6.12 (SPECIAL)

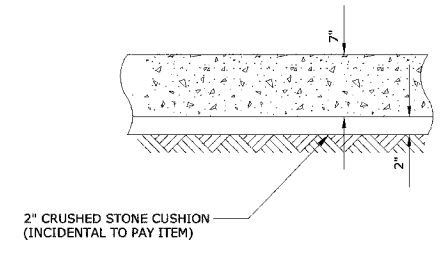

P.C.C. DRIVEWAY PAVEMENT DETAIL

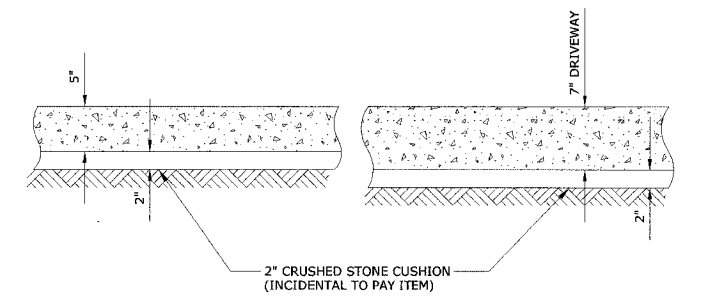

P.C.C. SIDEWALK

Drawing file: W:\Projects\32006353 - 46th St. Resurf & Streets\Drawings-Details.dwg Nov 01, 2006 - 11:36am

HANCOCK ENGINEERING ♦ Civil Engineers ♦ Municipal Consultants ♦ Established 1911
 9933 Roosevelt Road Westchester, Illinois 60154-2780
 Phone: 708/965-0300 Fax: 708/965-1212

46th STREET RESURFACING PROJECT
VILLAGE OF FOREST VIEW, ILLINOIS

DETAILS

SCALE:	NONE	SHEET	12
DRAWN BY:	MK/DMM/LEV/TSG	OF	24
BOOK NO.:	SDR33		
DATE:	11-1-06		
REVISION:			
E.H.E. NO.:	320-05-35101		