

SIDEROAD AND ENTRANCE DETAILS

| | | | | |
|---------------------|---------------|-------------------------------|------------------|--------------------|
| FAP NO. | SECTION ** | COUNTY SALINE | SHEET 18 | TOTAL SHEETS 16 |
| STA. | | TO STA. | | |
| FED. ROAD DIST. NO. | | ILLINOIS | FED. AID PROJECT | |
| 859 & 132 | | **IRS-2-20XRS-103,104,105RS-2 | | C.N. 98945 |

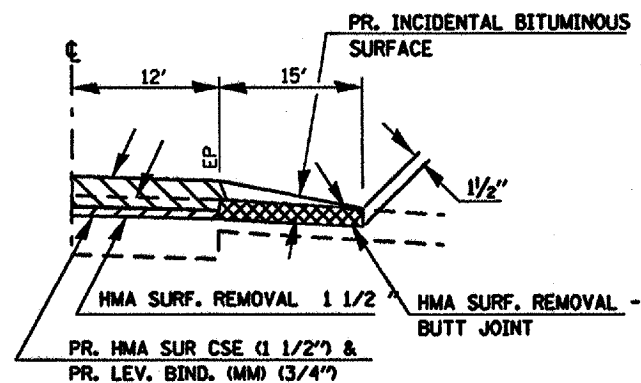

SIDE ROAD SEC. B-B
EX. BIT. OR CONC. SURFACE

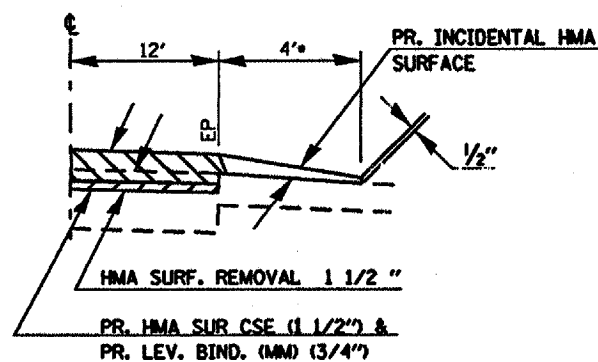

PE OR CE SEC. A-A
EX. BIT. OR CONC. SURFACE
OR END OF BIT. APRON

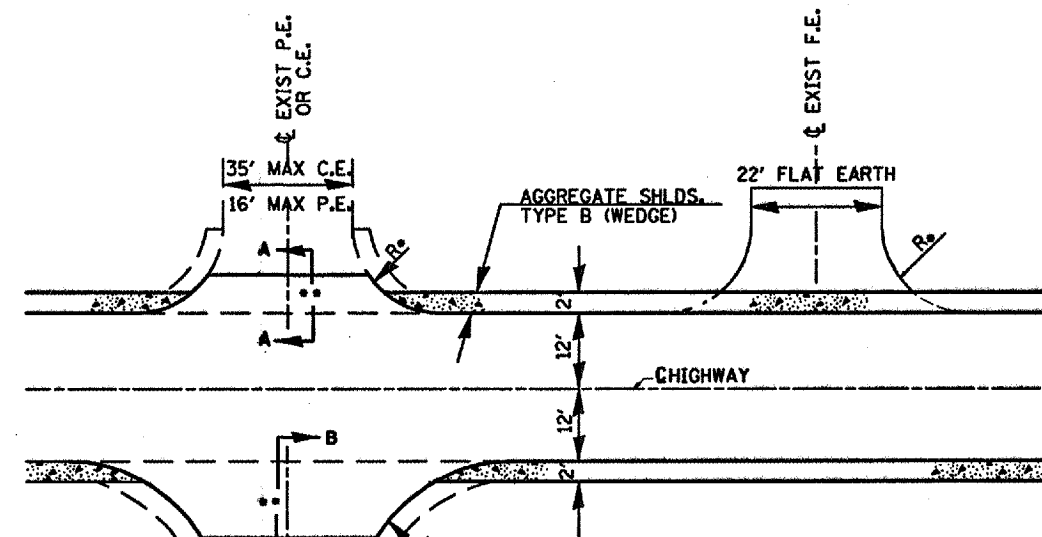

•MATCH EXISTING RADIUS
•RESURFACE AS INDICATED AT LEFT.

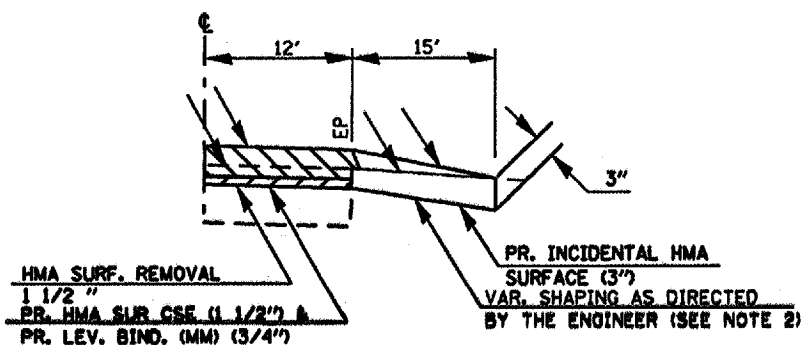

SIDE ROAD SEC. B-B
EX. AGGREGATE SURFACE
(SEE NOTE 1)

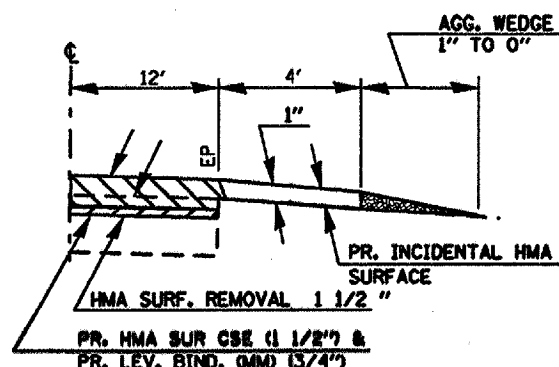

PE OR CE SEC. A-A
EX. AGGREGATE SURFACE

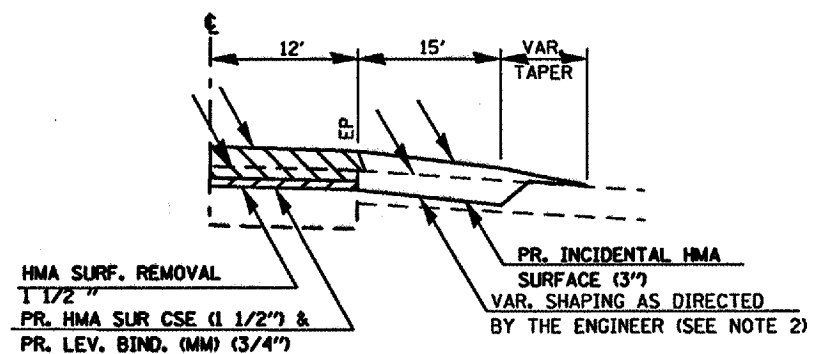

SIDE ROAD SEC. B-B
EX. OIL & CHIP SURFACE
(SEE NOTE 1)

NOTES

1. IF EXISTING SUBBASE IS INADEQUATE, AS DETERMINED BY THE ENGINEER, THE SIDE ROADS SHALL BE CORED OUT AND AGGREGATE SUBBASE, TYPE B SHALL BE PLACED FOR BASE. THE COST OF CORING OUT THE SIDE ROAD AND ANY AGGREGATE BASE COURSE SHALL BE PAID FOR AS SPECIFIED IN ART. 109.04 OF THE STANDARD SPECIFICATIONS FOR ROAD AND BRIDGE CONSTRUCTION. IF EXISTING SUBBASE IS DETERMINED TO BE ADEQUATE, THE PREPARATION OF THE BASE SHALL BE CONSTRUCTED ACCORDING TO ARTICLE 406.19.
2. VARIABLE SHAPING IS INCLUDED IN THE COST OF INCIDENTAL HOT-MIX ASPHALT SURFACE.

ENTRANCE SCHEDULE

| TYPE | NUMBER OF ENTRANCES |
|------|---------------------|
| P.E. | 75 |
| C.E. | 18 |
| S.R. | 23 |