

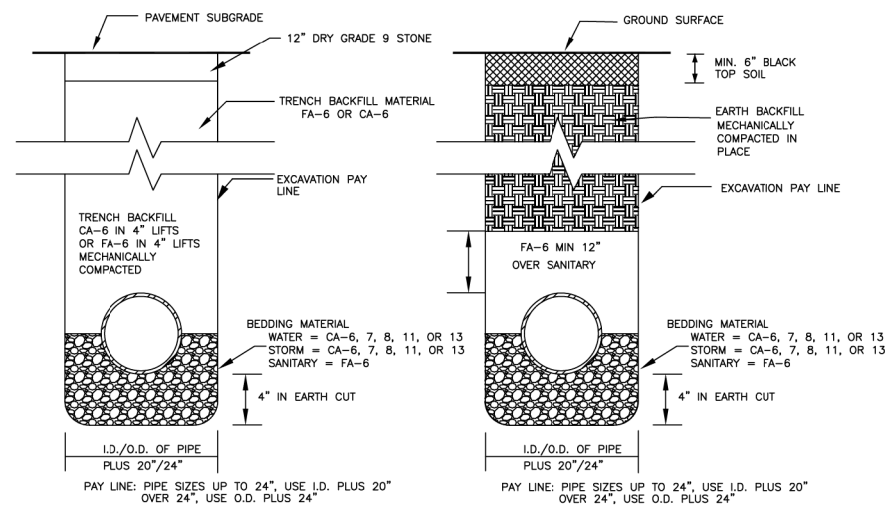

VILLAGE OF ALGONQUIN  
PUBLIC WORKS DEPARTMENT  
110 MEYER DRIVE  
ALGONQUIN, IL 60102-2442  
PH: 847-658-2754  
FX: 847-658-2759  
WWW.ALGONQUIN.ORG



**TRENCH SECTION  
IN PAVED AREA**

**TRENCH SECTION  
IN UNPAVED AREA**

Spec Book Date 02-13-2006

TRENCH SECTIONS	
Village of Algonquin Specifications & Details Guide	
Drawn By: Shawn M. Hurltig	Revision Date 01/17/2005



VILLAGE OF ALGONQUIN  
PUBLIC WORKS DEPARTMENT  
110 MEYER DRIVE  
ALGONQUIN, IL 60102-2442  
PH: 847-658-2754  
FX: 847-658-2759  
WWW.ALGONQUIN.ORG

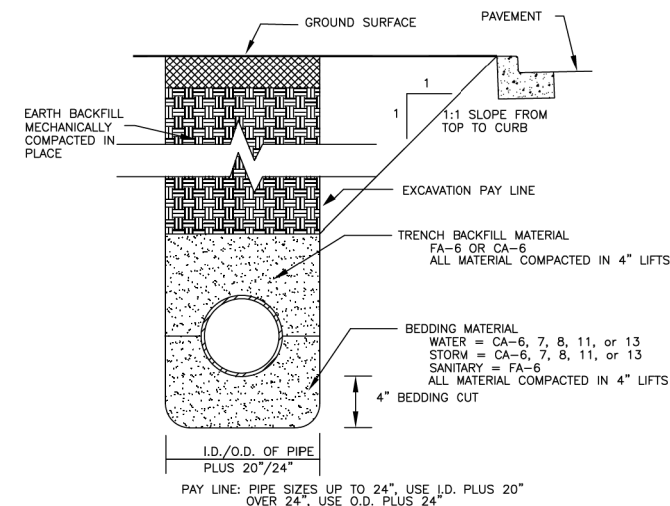

**TRENCH SECTION FOR PIPELINES  
ADJACENT TO PAVEMENTS**

Spec Book Date 02-13-2006

TRENCH ADJACENT TO PAVEMENT	
Village of Algonquin Specifications & Details Guide	
Drawn By: Shawn M. Hurltig	Revision Date 01/17/2005



VILLAGE OF ALGONQUIN  
PUBLIC WORKS DEPARTMENT  
110 MEYER DRIVE  
ALGONQUIN, IL 60102-2442  
PH: 847-658-2754  
FX: 847-658-2759  
WWW.ALGONQUIN.ORG

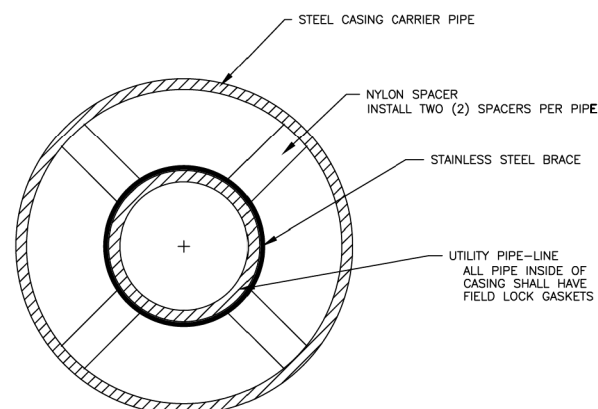

NOTES:  
AT COMPLETION OF INSTALLATION OF PIPE, CASING ENDS  
SHALL BE SEALED WITH CONCRETE BULKHEADS

**INSTALLATION OF PIPE  
WITHIN CASING PIPE**

Spec Book Date 02-13-2006

CASING PIPE	
Village of Algonquin Specifications & Details Guide	
Drawn By: Shawn M. Hurltig	Revision Date 02/13/2005



VILLAGE OF ALGONQUIN  
PUBLIC WORKS DEPARTMENT  
110 MEYER DRIVE  
ALGONQUIN, IL 60102-2442  
PH: 847-658-2754  
FX: 847-658-2759  
WWW.ALGONQUIN.ORG

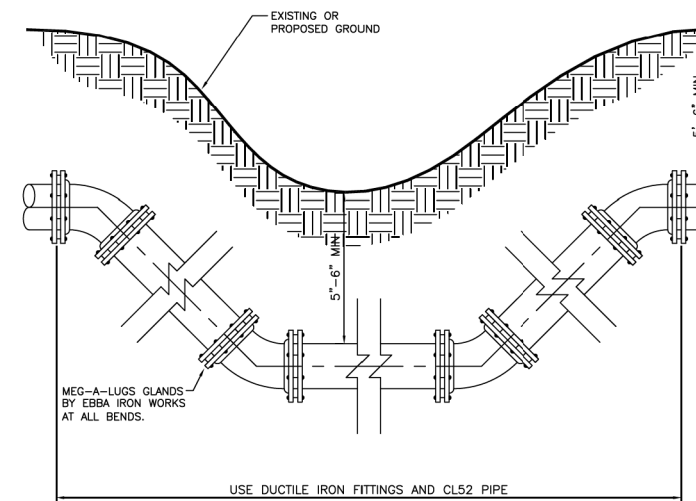

**WATER MAIN LOWERING**

Spec Book Date 02-13-2006

WATERMAIN LOWERING	
Village of Algonquin Specifications & Details Guide	
Drawn By: Shawn M. Hurltig	Revision Date 01/17/2005

FILE NAME =	USER NAME = akw	DESIGNED ALGONQUIN	REVISED -
...\\D160F72-sht-details-43-VOA-01.dgn		DRAWN	REVISED -
	PLOT SCALE = 40.0000' / in.	CHECKED	REVISED -
	PLOT DATE = 5/2/2012	DATE -	REVISED -

**STATE OF ILLINOIS  
DEPARTMENT OF TRANSPORTATION**

**VILLAGE OF ALGONQUIN DETAILS**

SCALE: NONE SHEET NO. 1 OF 4 SHEETS STA. TO STA.

O.R. RTE.	SECTION	COUNTY	TOTAL SHEETS	SHEET NO.
0003	18A-2	MCHENRY	825	388
CONTRACT NO. 60F72				
FED. ROAD DIST. NO. 1 ILLINOIS FED. AID PROJECT				