

CNTY/STATE/CITY

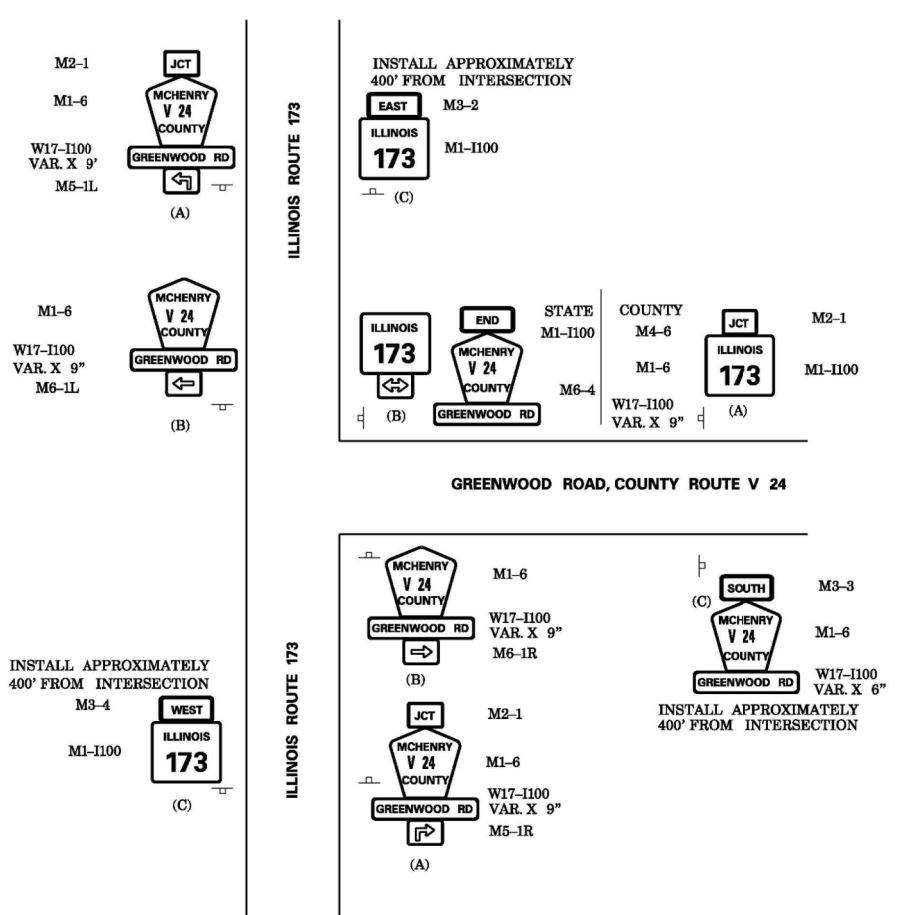

CNTY/STATE

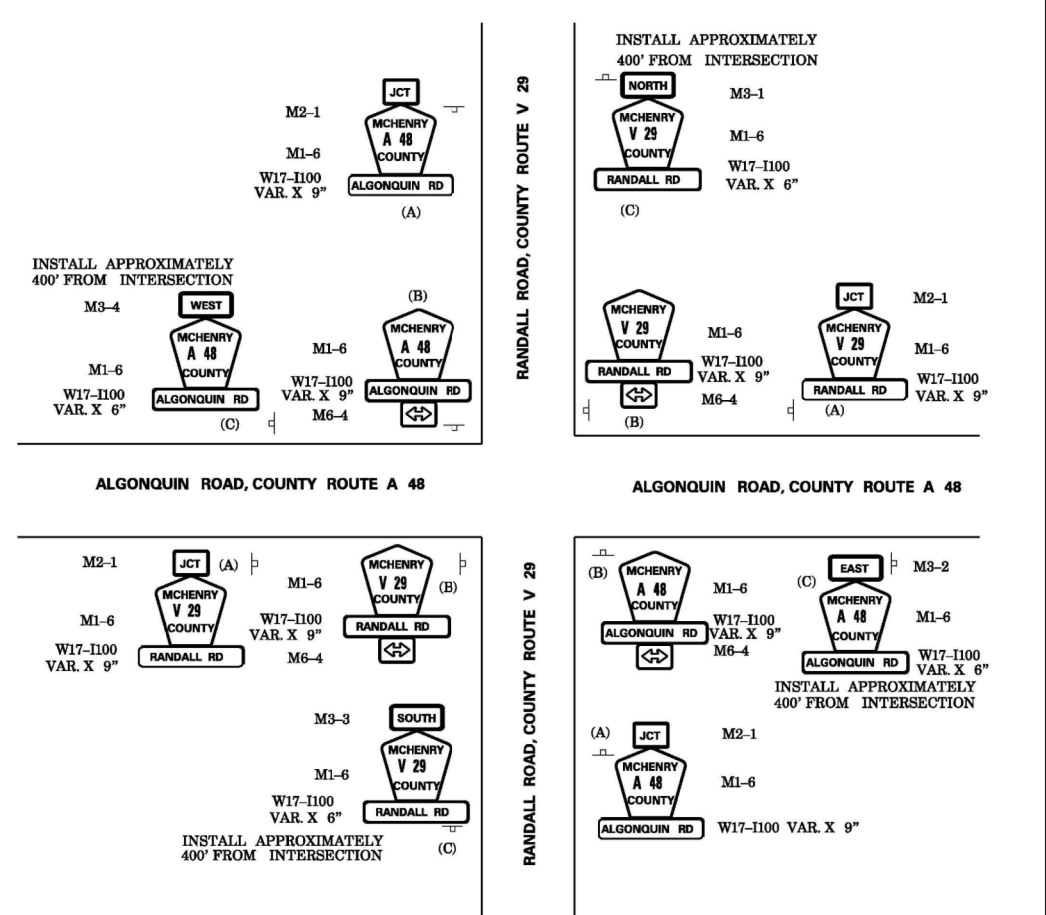

CNTY/CNTY

JUNCTION SIGN LOCATION (A):
 IN URBAN AREAS, THE JUNCTION SIGN SHALL BE INSTALLED IN THE BLOCK PRECEDING THE INTERSECTION.
 IN RURAL AREAS, THE JUNCTION SIGN SHALL BE INSTALLED AT LEAST 400 FEET IN ADVANCE OF THE INTERSECTION.

CONFIRMATION SIGN LOCATIONS (C):
 CONFIRMATION SIGN ASSEMBLIES SHALL BE INSTALLED APPROXIMATELY 400 FEET FROM THE INTERSECTION.

SIGN TYPE	SIGN CODE	SIGN COLOR	SIGN SIZE	LEGENDSYMBOL
STATE RTE. MARKER	M1-I100	BLACK ON WHITE	24" X 24"	ILLINOIS "XX"
COUNTY RTE. MARKER	M1-6	YELLOW ON BLUE	24" X 24"	MCHENRY "XXX" COUNTY
JUNCTION (STATE RTE.)	M2-1	BLACK ON WHITE	21" X 15"	JUNCTION
JUNCTION (CTY. RTE.)	M2-1	YELLOW ON BLUE	21" X 15"	JUNCTION
DIRECTION (STATE RTE.)	M3-1	BLACK ON WHITE	24" X 12"	NORTH
DIRECTION (STATE RTE.)	M3-2	BLACK ON WHITE	24" X 12"	EAST
DIRECTION (STATE RTE.)	M3-3	BLACK ON WHITE	24" X 12"	SOUTH
DIRECTION (STATE RTE.)	M3-4	BLACK ON WHITE	24" X 12"	WEST
DIRECTION (CTY. RTE.)	M3-1	YELLOW ON BLUE	24" X 12"	NORTH
DIRECTION (CTY. RTE.)	M3-2	YELLOW ON BLUE	24" X 12"	EAST
DIRECTION (CTY. RTE.)	M3-3	YELLOW ON BLUE	24" X 12"	SOUTH
DIRECTION (CTY. RTE.)	M3-4	YELLOW ON BLUE	24" X 12"	WEST
END	M4-6	YELLOW ON BLUE	24" X 12"	END
BEGIN	M4-11	YELLOW ON BLUE	24" X 12"	BEGIN
ADVANCE ARROW	M5-1L	YELLOW ON BLUE	15" X 21"	ADV. LEFT ARROW
ADVANCE ARROW	M5-1R	YELLOW ON BLUE	15" X 21"	ADV. RIGHT ARROW
ARROW	M6-1L	YELLOW ON BLUE	15" X 21"	LEFT ARROW
ARROW	M6-1R	YELLOW ON BLUE	15" X 21"	RIGHT ARROW
ARROW (STATE RTE.)	M6-4	BLACK ON WHITE	15" X 21"	DOUBLE ARROW
ARROW (CTY. RTE.)	M6-4	YELLOW ON BLUE	15" X 21"	DOUBLE ARROW
ROAD NAME (STATE RTE.)	W17-I100	BLACK ON WHITE	VARIABLE X 9"	FOR SIGNS A & B
ROAD NAME (STATE RTE.)	W17-I100	BLACK ON WHITE	VARIABLE X 6"	FOR SIGN C
ROAD NAME (CTY. RTE.)	W17-I100	YELLOW ON BLUE	VARIABLE X 9"	FOR SIGNS A & B
ROAD NAME (CTY. RTE.)	W17-I100	YELLOW ON BLUE	VARIABLE X 6"	FOR SIGN C