

ELEVATION AT S. ABUT.

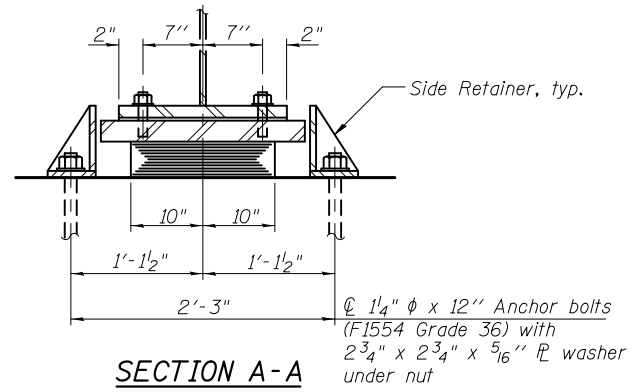

SECTION A-A

TYPE I ELASTOMERIC EXP. BRG.

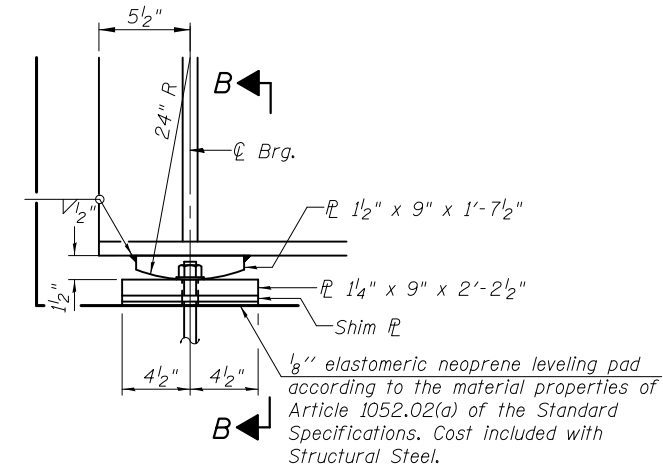

ELEVATION AT N. ABUTMENT

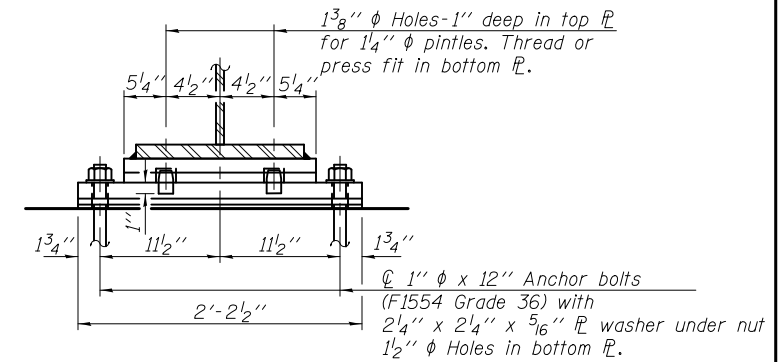

SECTION B-B

FIXED BEARING

(No. Required = 10)

Notes:

Anchor bolts shall be ASTM F1554 all-thread (or an Engineer-approved alternate material) of the grade(s) and diameter(s) specified. The corresponding specified grade of AASHTO M314 anchor bolts may be used in lieu of ASTM F1554.

Anchor bolts at fixed bearings may be either cast in place or installed in holes drilled after the supported member is in place.

Anchor bolts for side retainers may be cast in place or installed in holes drilled before or after members are in place.

Drilled and set anchor bolts shall be installed according to Article 521.06 of the Standard Specifications.

Side retainers and other steel members required for the elastomeric bearing assembly shall be included in the cost of Elastomeric Bearing Assembly, Type I.

The structural steel plates of the Bearing Assembly shall conform to the requirements of AASHTO M 270 Grade 50.

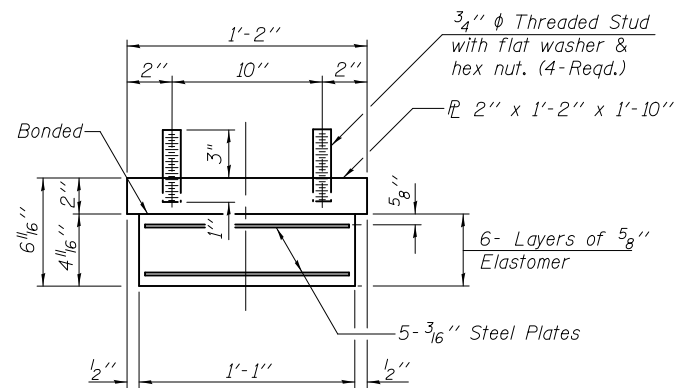

BEARING ASSEMBLY

Note:

Shim plates shall not be placed under Bearing Assembly.

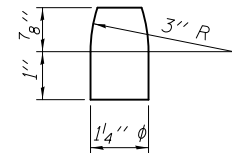

PINTLE

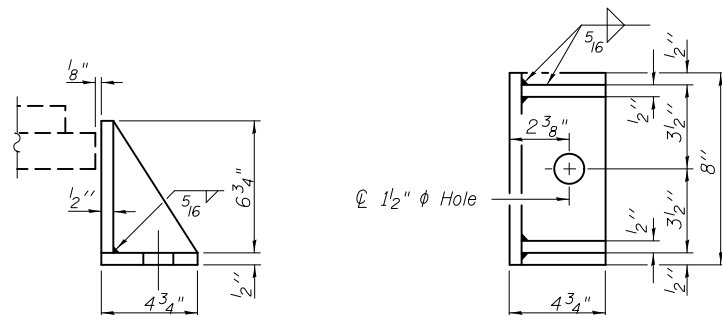

SIDE RETAINER

Equivalent rolled angle with stiffeners will be allowed in lieu of welded plates.

BILL OF MATERIAL

Item	Unit	Total
Elastomeric Bearing Assembly Type I	Each	10
Anchor Bolts, 1"	Each	20
Anchor Bolts, 1 1/4"	Each	20

5/2/2012 4:16:42 PM I:\2154\Cad\sheet\Roadway\20-Structures & Walls\01.SN 056-0077\0560077-60F72-20-BD.dgn



450 E Devon Ave, Suite 300
Itasca, Illinois 60143
Tel: 630.773.3900 Fax: 630.773.3975
www.civiltechinc.com

DRAWN	- M. LANGE	REVISED	-
DESIGNED	- D. ATKINS	REVISED	-
CHECKED	- G. HATLESTAD	REVISED	-
DATE	- 5/3/2012	REVISED	-

STATE OF ILLINOIS
DEPARTMENT OF TRANSPORTATION

BEARING DETAILS
ILLINOIS ROUTE 31 OVER CRYSTAL CREEK
STRUCTURE NO. 056-0077

SHEET NO. SA20 OF SA33 SHEETS

O.R. RTE.	SECTION	COUNTY	TOTAL SHEETS	SHEET NO.
0003	18A-2	MCHENRY	825	480
CONTRACT NO. 60F72				
ILLINOIS FED. AID PROJECT				