

STEEL PILE TABLE

Designation	Depth d	Flange width br	Web and Flange thickness t	Encasement diameter A
HP 14x117	14 1/4"	14 7/8"	1 3/16"	30"
x102	14"	14 3/4"	1/16"	30"
x89	13 7/8"	14 3/4"	5/8"	30"
x73	13 5/8"	14 5/8"	1/2"	30"
HP 12x84	12 1/4"	12 1/4"	1/16"	24"
x74	12 1/8"	12 1/4"	5/8"	24"
x63	12"	12 1/8"	1/2"	24"
x53	11 3/4"	12"	7/16"	24"
HP 10x57	10"	10 1/4"	9/16"	24"
x42	9 3/4"	10 1/8"	7/16"	24"
HP 8x36	8"	8 1/8"	7/16"	18"

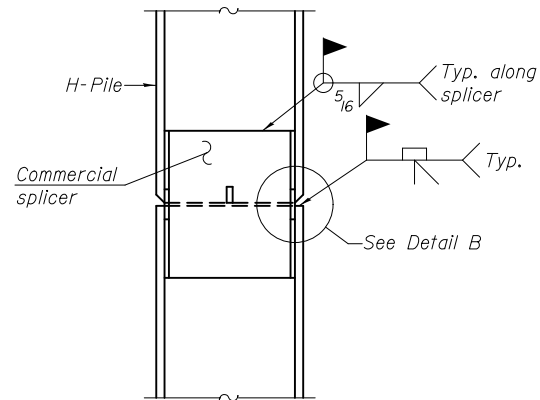

ELEVATION

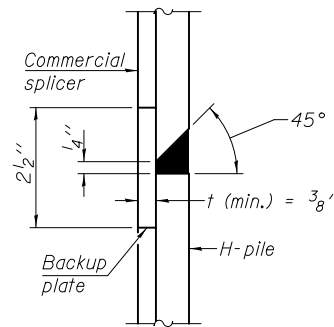

DETAIL "B"

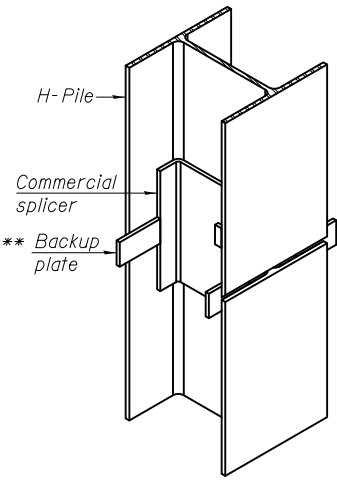

ISOMETRIC VIEW

WELDED COMMERCIAL SPLICE

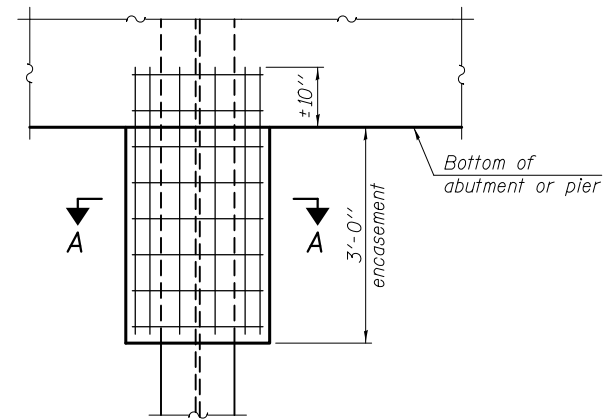

ELEVATION

PILE ENCASEMENT

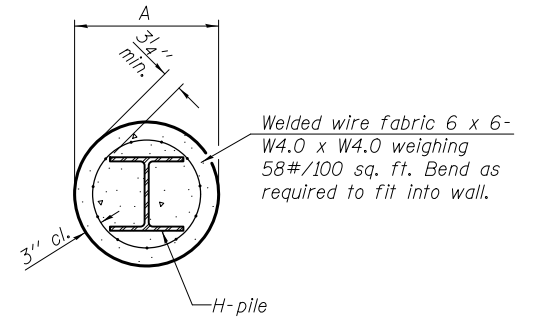

SECTION A-A

Note:
Forms for encasement may be omitted when soil conditions permit.

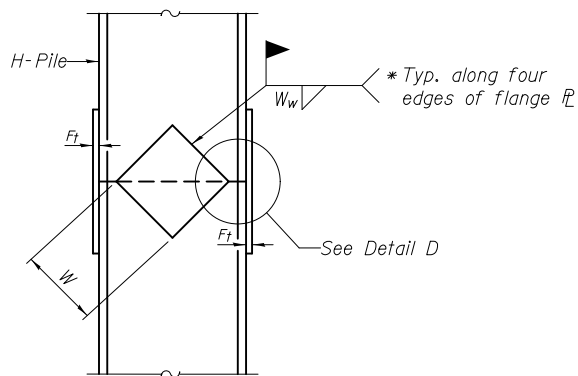

ELEVATION

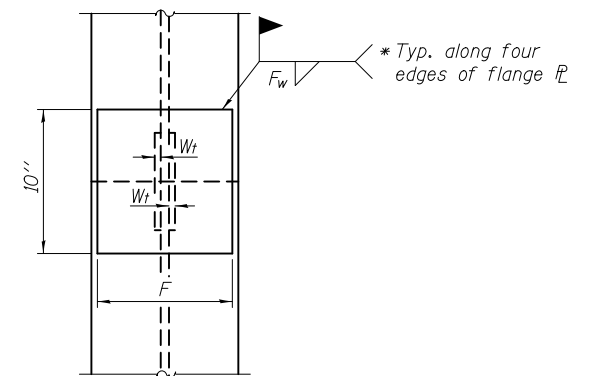

END VIEW

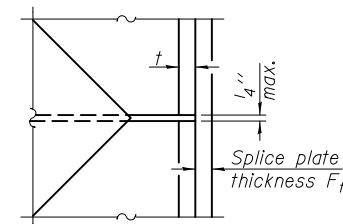

DETAIL D

WELDED PLATE FIELD SPLICE

Designation	F	F _t	F _w	W	W _t	W _w
HP 14x117	12 1/2"	1"	7/8"	7 3/4"	5/8"	1/2"
x102	12 1/2"	7/8"	3/4"	7 3/4"	5/8"	1/2"
x89	12 1/2"	3/4"	1/16"	7 3/4"	5/8"	1/2"
x73	12 1/2"	5/8"	9/16"	7 3/4"	5/8"	1/2"
HP 12x84	10"	7/8"	1/16"	6 1/2"	5/8"	1/2"
x74	10"	7/8"	1/16"	6 1/2"	5/8"	1/2"
x63	10"	5/8"	1/2"	6 1/2"	1/2"	3/8"
x53	10"	5/8"	1/2"	6 1/2"	1/2"	3/8"
HP 10x57	8"	3/4"	9/16"	5 1/4"	1/2"	3/8"
x42	8"	5/8"	9/16"	5 1/4"	1/2"	3/8"
HP 8x36	7"	5/8"	7/16"	4 1/4"	1/2"	3/8"

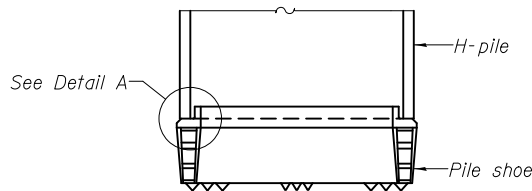

ELEVATION

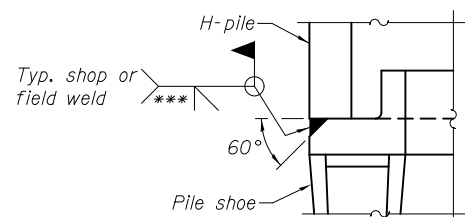

DETAIL A

H-PILE SHOE ATTACHMENT

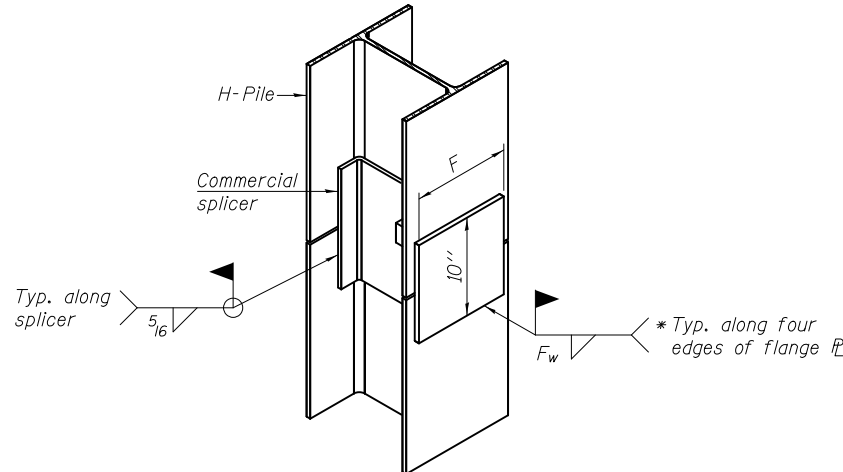

ISOMETRIC VIEW

WELDED COMMERCIAL SPLICE ALTERNATE

- * Interrupt welds 1/4" from end of web and/or each flange.
- ** Remove portions of backup plates that extend outside the flanges.
- *** Weld size per pile shoe manufacturer (5/16" min.).

Note:
The steel H-piles shall be according to AASHTO M270 Grade 50.

4:20:30 PM 4/25/2012 5/2/2012 I:\2154\cad\sheet\Roadway\20-STRUCTURES & WALLS\04-SN_056-0079\0560079-60F72-22-PD.dgn

F-HP 7-1-10

CIVILTECH
 450 E Devon Ave, Suite 300
 Itasca, Illinois 60143
 Tel: 630.773.3900 Fax: 630.773.3975
 www.civiltechinc.com

DRAWN	- M. LANGE	REVISED	-
DESIGNED	- D. ATKINS	REVISED	-
CHECKED	- G. HATLESTAD	REVISED	-
DATE	- 5/3/2012	REVISED	-

**STATE OF ILLINOIS
DEPARTMENT OF TRANSPORTATION**

**PILE DETAILS
NB EXIT RAMP (RAMP B) OVER CRYSTAL CREEK
STRUCTURE NO. 056-0079**

SHEET NO. SC22 OF SC29 SHEETS

O.R. RTE.	SECTION	COUNTY	TOTAL SHEETS	SHEET NO.
0003	18A-2	MCHENRY	825	547
CONTRACT NO. 60F72				
ILLINOIS FED. AID PROJECT				