

NOTE

1. GRADING OF THE FLAT AREA REQUIRED FOR THE PLACEMENT OF THE IMPACT ATTENUATOR AND TEMPORARY CONCRETE BARRIER SHALL BE INCLUDED IN THE CONTRACT UNIT PRICE FOR CURB REMOVAL (PARTIAL).
2. SEE IDOT STANDARD DETAIL 643001, SAND MODULE IMPACT ATTENUATORS.

**GRADING FOR IMPACT ATTENUATOR
AND TEMPORARY CONCRETE BARRIER PLACEMENT
STA. 3966+30 TO STA. 3968+00**

NOTE: TEMPORARY CONCRETE BARRIER AND IMPACT ATTENUATORS NOT SHOWN

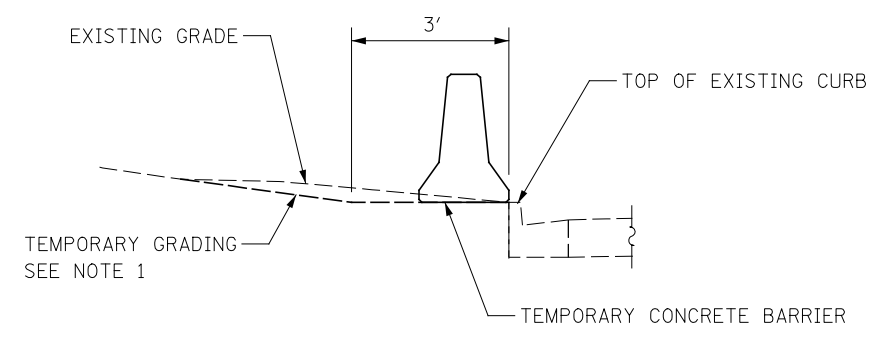

**TEMPORARY CONCRETE BARRIER PLACEMENT
STA. 3959+50 TO STA. 3966+30**

USER NAME = *USER*	DESIGNED - <i>DMS</i>	REVISED -	STATE OF ILLINOIS DEPARTMENT OF TRANSPORTATION	MAINTENANCE OF TRAFFIC DETAILS				F.A.P. RTE.	SECTION	COUNTY	TOTAL SHEETS	SHEET NO.	
	DRAWN - <i>KEA</i>	REVISED -		SCALE:	SHEET NO.	OF SHEETS	STA.	TO STA.	338/IL 59	2011-035-I	DUPAGE	181	13
PLOT SCALE = *SCALE*	CHECKED - <i>PJO</i>	REVISED -						CONTRACT NO. 60P41			ILLINOIS FED. AID PROJECT		
PLOT DATE = *DATE*	DATE - <i>03-22-2012</i>	REVISED -											