

1 SUPPLY FAN SF-1 P&ID
(NOTE 3)

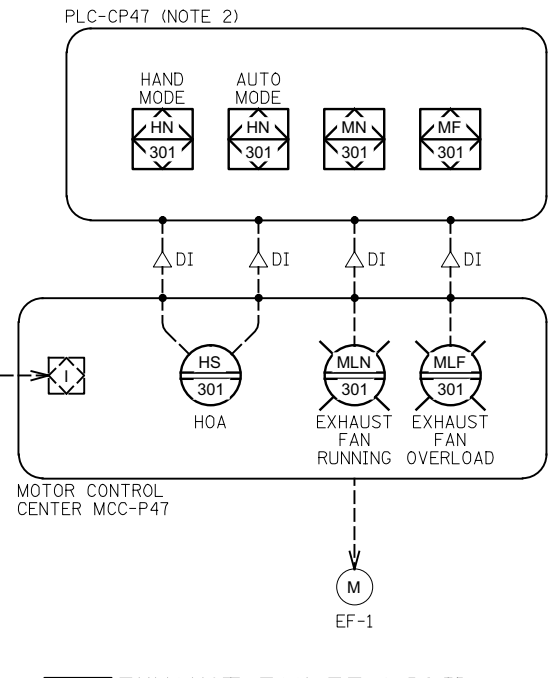

2 EXHAUST FAN EF-1 P&ID

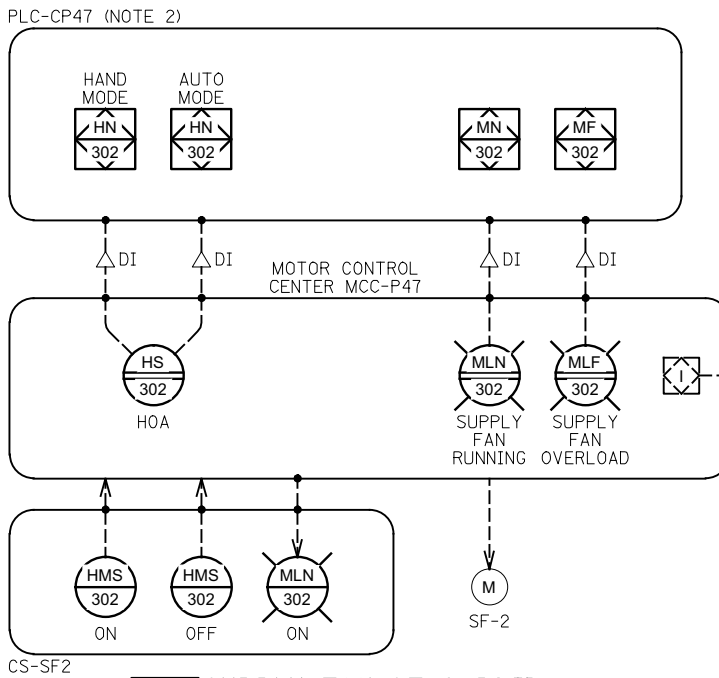

3 SUPPLY FAN SF-2 P&ID
(NOTE 3)

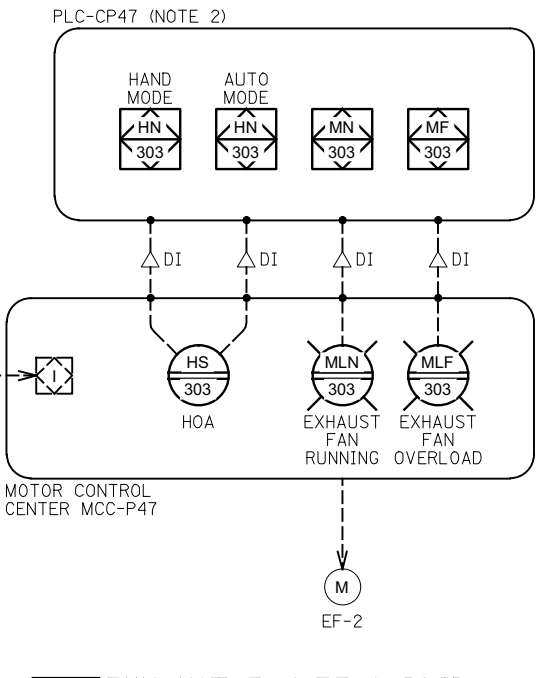

4 EXHAUST FAN EF-2 P&ID

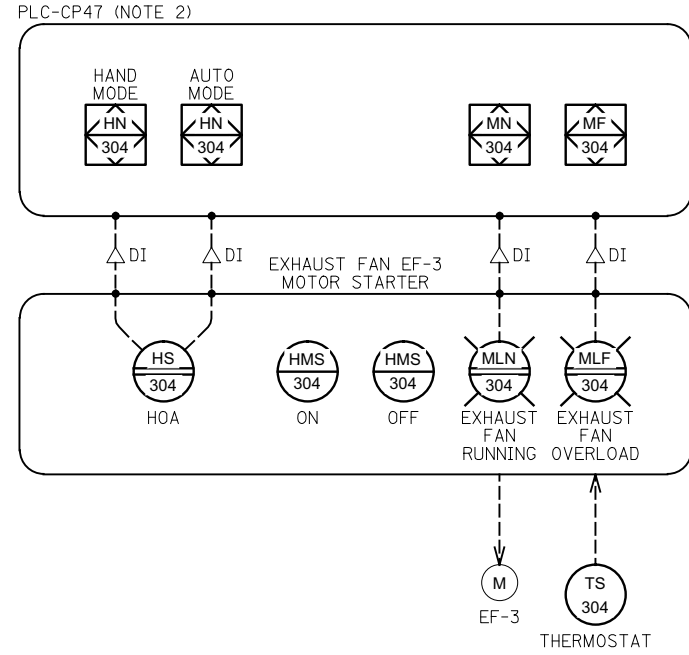

5 EXHAUST FAN EF-5 P&ID

- NOTES:
- SEE SHEETS GI-1 AND GI-2 FOR INSTRUMENTATION SYMBOL LISTS, ABBREVIATIONS, AND GENERAL NOTES.
 - REFER TO SPECIFICATION SECTION 40 94 23 FOR SCADA REQUIREMENTS.
 - REFER TO DETAIL 2 ON SHEET I-9 FOR AUTOMATIC START INPUT FROM GAS MONITORING PANEL.