

PIPE BOLLARD DETAIL
NOT TO SCALE

NOTE
SEE SHEET E4A FOR NUMBER OF BOLLARDS AND SPACING.

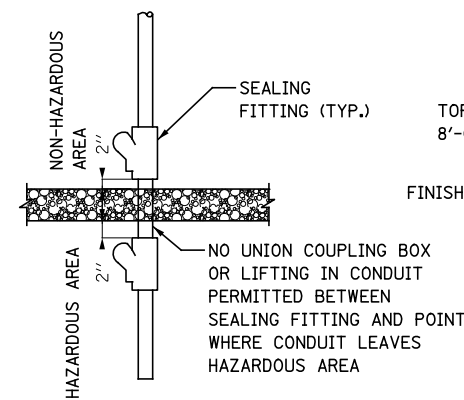

CONDUIT SEALING DETAIL
NOT TO SCALE

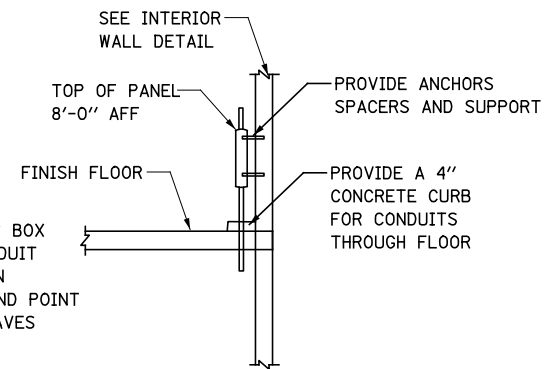

WALL MOUNT PANEL DETAIL
NOT TO SCALE

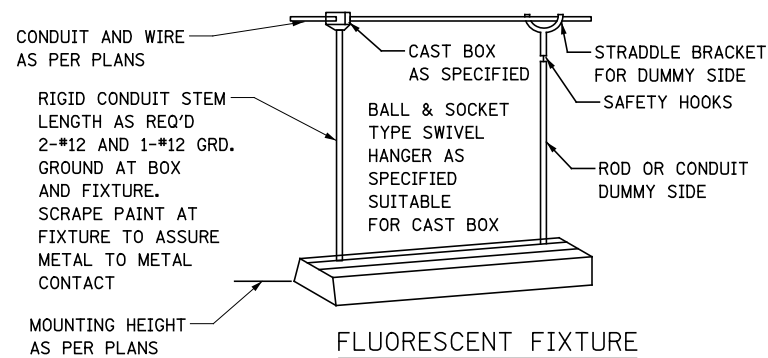

FLUORESCENT FIXTURE MOUNTING DETAIL
NOT TO SCALE

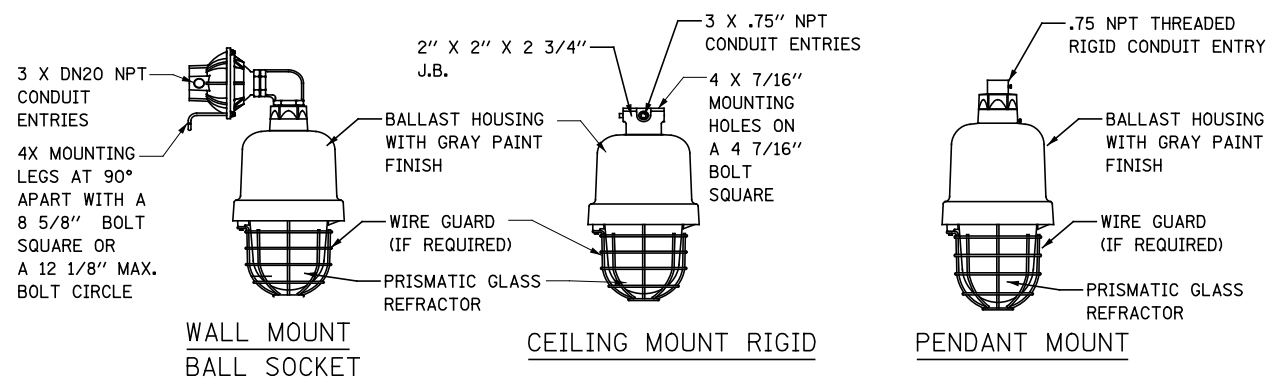

TYPICAL METAL HALIDE LIGHT FIXTURE INSTALLATION
NOT TO SCALE

USER NAME = *USER*	DESIGNED - MCP	REVISED -
	DRAWN - MLB	REVISED -
PLOT SCALE = *SCALE*	CHECKED - MCP	REVISED -
PLOT DATE = *DATE*	DATE 03-22-2012	REVISED -

F.A.P. RTE.	SECTION	COUNTY	TOTAL SHEETS	SHEET NO.
338/IL 59	2011-035-I	DUPAGE	181	179
CONTRACT NO. 60P41				
ILLINOIS FED. AID PROJECT				