

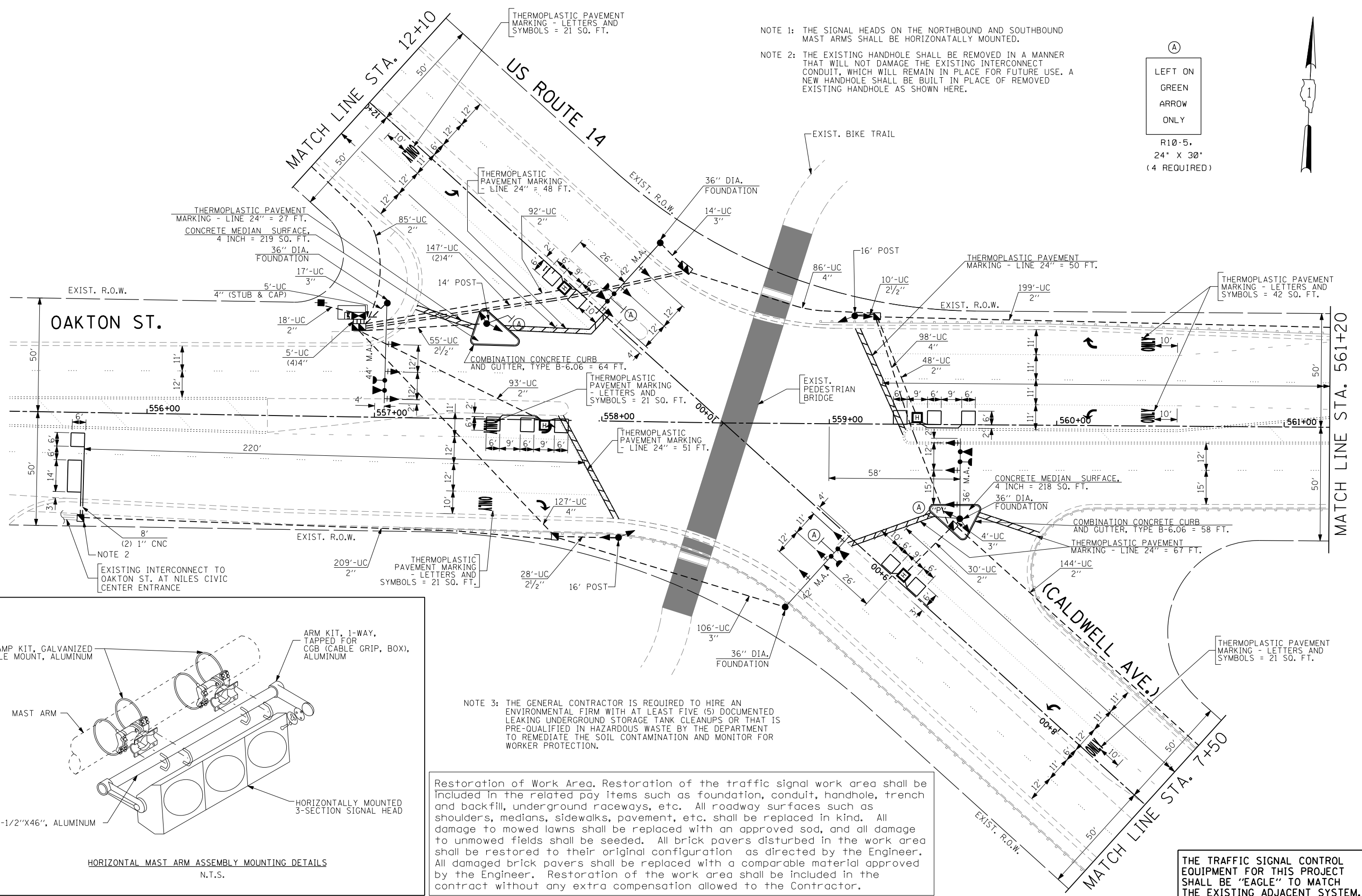

(A)  
LEFT ON  
GREEN  
ARROW  
ONLY  
R10-5,  
24" X 30"  
(4 REQUIRED)

NOTE 1: THE SIGNAL HEADS ON THE NORTHBOUND AND SOUTHBOUND MAST ARMS SHALL BE HORIZONTALLY MOUNTED.  
NOTE 2: THE EXISTING HANDHOLE SHALL BE REMOVED IN A MANNER THAT WILL NOT DAMAGE THE EXISTING INTERCONNECT CONDUIT, WHICH WILL REMAIN IN PLACE FOR FUTURE USE. A NEW HANDHOLE SHALL BE BUILT IN PLACE OF REMOVED EXISTING HANDHOLE AS SHOWN HERE.



NOTE 2  
EXISTING INTERCONNECT TO OAKTON ST. AT NILES CIVIC CENTER ENTRANCE

NOTE 3: THE GENERAL CONTRACTOR IS REQUIRED TO HIRE AN ENVIRONMENTAL FIRM WITH AT LEAST FIVE (5) DOCUMENTED LEAKING UNDERGROUND STORAGE TANK CLEANUPS OR THAT IS PRE-QUALIFIED IN HAZARDOUS WASTE BY THE DEPARTMENT TO REMEDIATE THE SOIL CONTAMINATION AND MONITOR FOR WORKER PROTECTION.

Restoration of Work Area, Restoration of the traffic signal work area shall be included in the related pay items such as foundation, conduit, handhole, trench and backfill, underground raceways, etc. All roadway surfaces such as shoulders, medians, sidewalks, pavement, etc. shall be replaced in kind. All damage to mowed lawns shall be replaced with an approved sod, and all damage to unmowed fields shall be seeded. All brick pavers disturbed in the work area shall be restored to their original configuration as directed by the Engineer. All damaged brick pavers shall be replaced with a comparable material approved by the Engineer. Restoration of the work area shall be included in the contract without any extra compensation allowed to the Contractor.

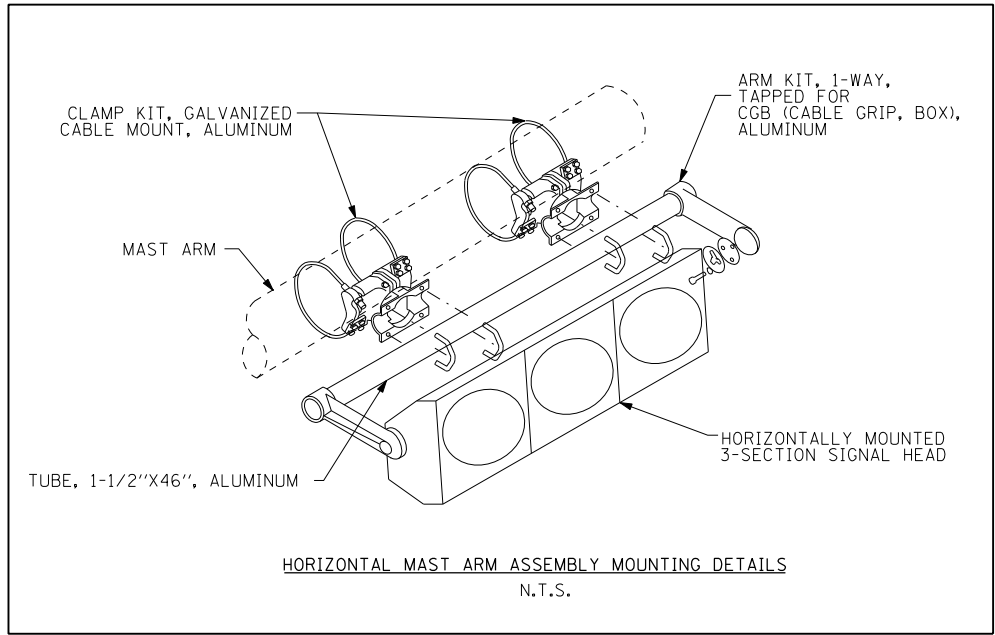

THE TRAFFIC SIGNAL CONTROL EQUIPMENT FOR THIS PROJECT SHALL BE "EAGLE" TO MATCH THE EXISTING ADJACENT SYSTEM.

FILE NAME = *FILE#	USER NAME = *USER#	DESIGNED - MA, PKG	REVISED -	<b>STATE OF ILLINOIS DEPARTMENT OF TRANSPORTATION</b>	<b>TRAFFIC SIGNAL INSTALLATION PLAN US ROUTE 14 (CALDWELL AVE.) AT OAKTON ST. (SHEET 1 OF 2)</b>			F.A.U. RT. = 3524	SECTION = 2011-210-TS	COUNTY = COOK	TOTAL SHEETS = 089	SHEET NO. = 056
	PLOT SCALE = *SCALE#	CHECKED - PKG	REVISED -		SCALE: 1"=20'	SHEET NO. OF SHEETS	STA. TO STA.	FINAL		CONTRACT NO. 60R44		
	PLOT DATE = *DATE#	DATE - 03/21/2012	REVISED -		FED. ROAD DIST. NO. - ILLINOIS FED. AID PROJECT							