

SIDEROAD AND ENTRANCE DETAILS

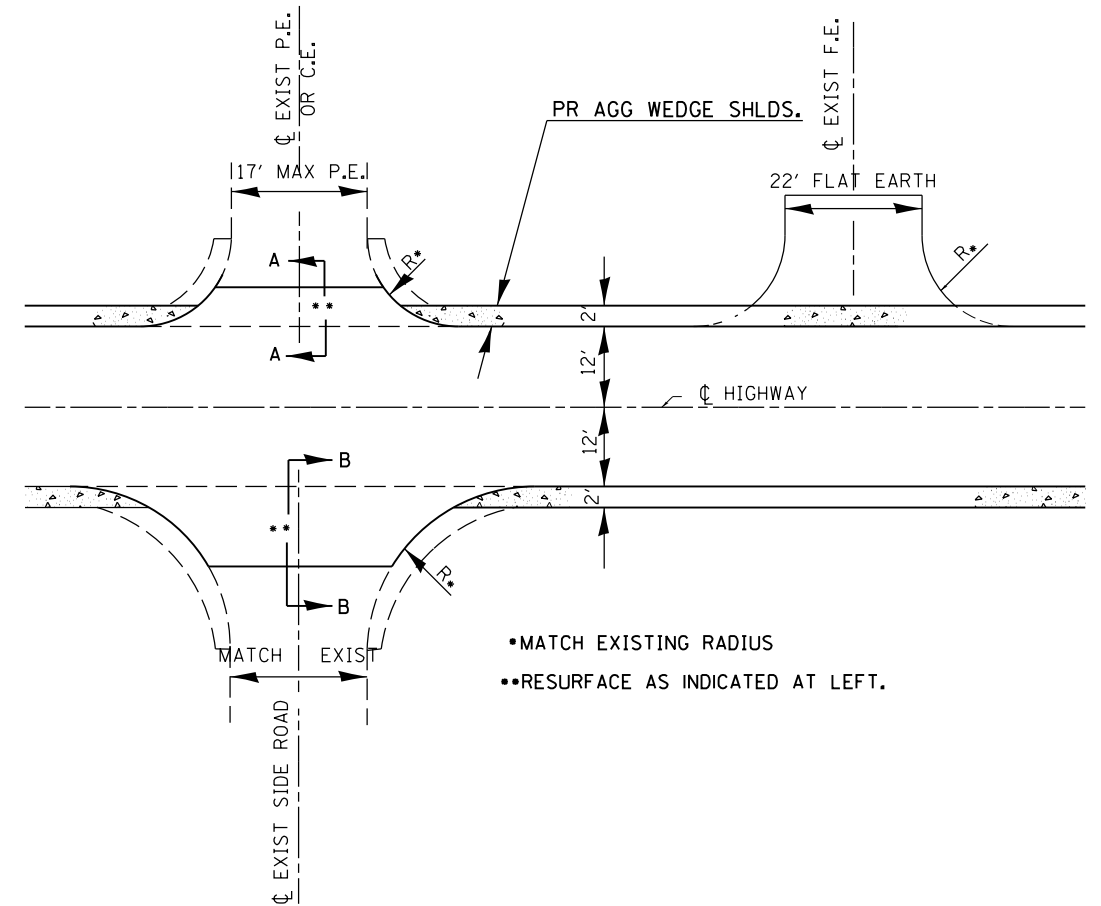
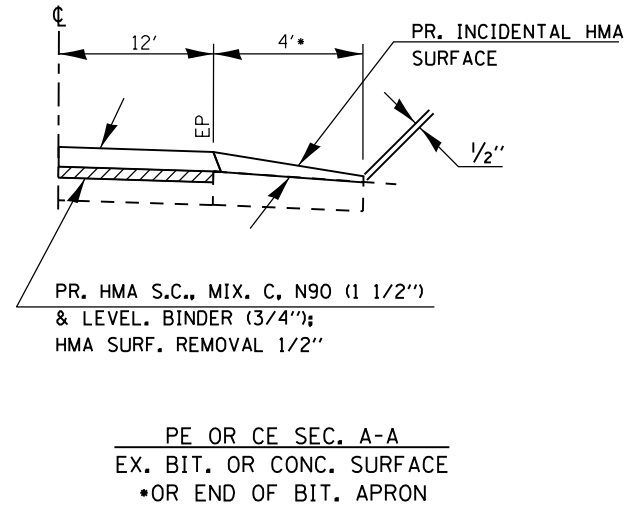
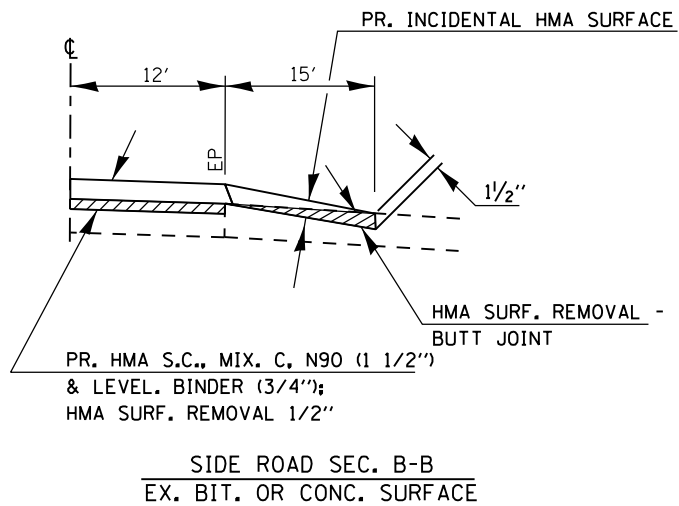

ENTRANCE SCHEDULE FOR LOCATION

| TYPE | NUMBER OF ENTRANCES |
|------|---------------------|
| P.E. | 5 |
| C.E. | 1 |

| RD. NAME | STA | INCIDENTAL HMA TON |
|-----------|---------|--------------------|
| MT MORIAH | 1568+50 | 12 |
| ELLIS | 1487+72 | 9 |
| TOTAL | | 21 |

* FAP 855
** (9.10)RS-2; (11.12)RS-3

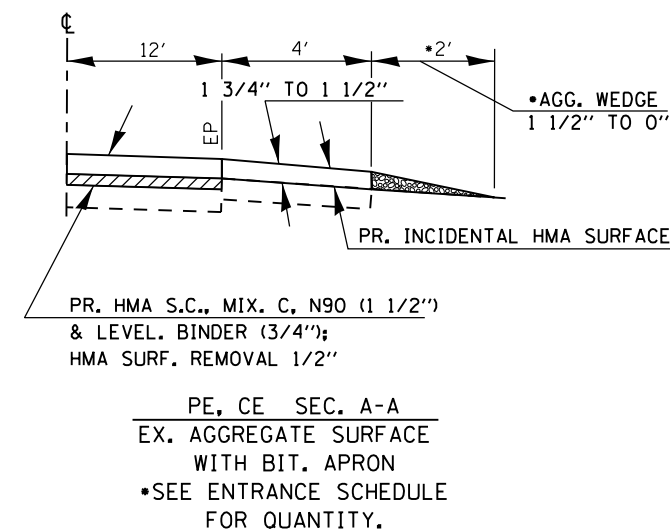
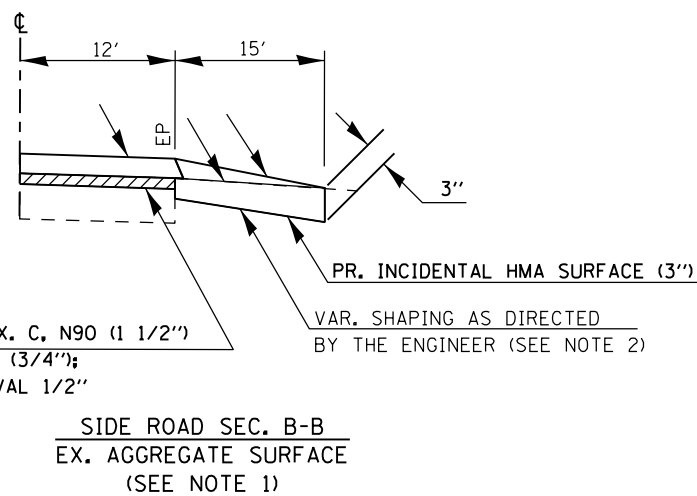

NOTES

- IF EXISTING SUBBASE IS INADEQUATE, AS DETERMINED BY THE ENGINEER, THE SIDE ROADS SHALL BE CORED OUT AND AGGREGATE SUBBASE, TYPE B SHALL BE PLACED FOR BASE. THE COST OF CORING OUT THE SIDE ROAD AND ANY AGGREGATE BASE COURSE SHALL BE PAID FOR AS SPECIFIED IN ART. 109.04 OF THE STANDARD SPECIFICATIONS FOR ROAD AND BRIDGE CONSTRUCTION. IF EXISTING SUBBASE IS DETERMINED TO BE ADEQUATE, THE PREPARATION OF THE BASE SHALL BE CONSTRUCTED ACCORDING TO ARTICLE 406.19.
- VARIABLE SHAPING IS INCLUDED IN THE COST OF INCIDENTAL HOT-MIX ASPHALT SURFACE.

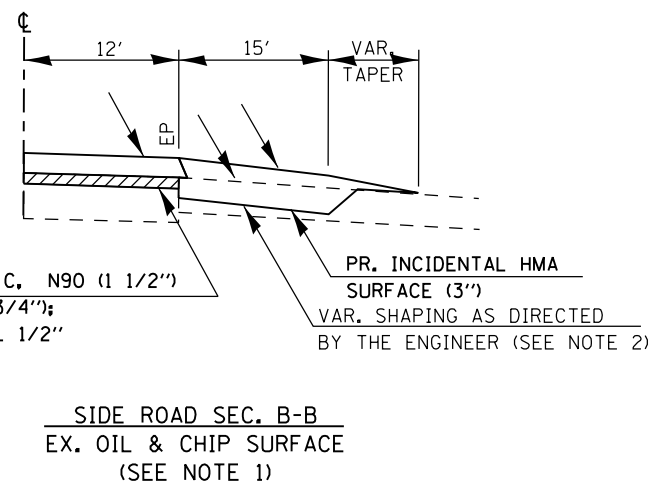

| | | | |
|---|-------------------------------|------------|-----------|
| FILE NAME = | USER NAME = \$USER\$ | DESIGNED - | REVISED - |
| et:\pw\work\p\dot\k\ell\eykd\d0290960\78290-sht-pln.dgn | | DRAWN - | REVISED - |
| | PLOT SCALE = 100.0000' / 1in. | CHECKED - | REVISED - |
| | PLOT DATE = 3/23/2012 | DATE - | REVISED - |

STATE OF ILLINOIS
DEPARTMENT OF TRANSPORTATION

SIDE ROAD AND ENTRANCE DETAIL

SCALE: SHEET OF SHEETS STA. TO STA.

| F.A.P. RTE. | SECTION | COUNTY | TOTAL SHEETS | SHEET NO. |
|---------------------------|---------|--------|--------------|--------------------|
| 869 | 105R-1 | SALINE | 26 | 24 |
| | | | | CONTRACT NO. 78290 |
| ILLINOIS FED. AID PROJECT | | | | |