

FABRIC BEARING PAD
(Interior)

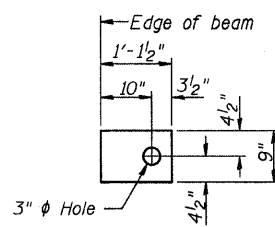

FABRIC BEARING PAD
(Exterior)

FIXED

Note: All bearing pads shall be 1" thick.

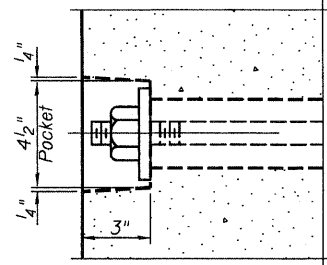

SECTION A-A

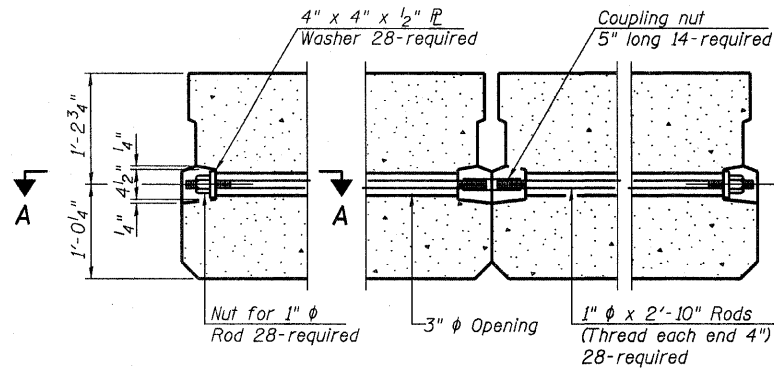

TYPICAL TRANSVERSE TIE ASSEMBLY

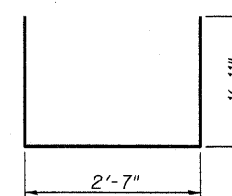

BAR S1(E)

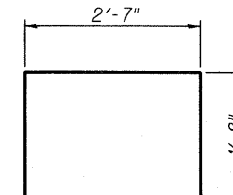

BAR S2(E)

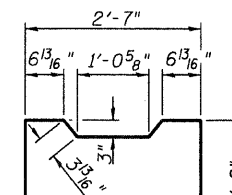

BAR U1(E)

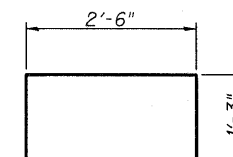

BAR U2(E)

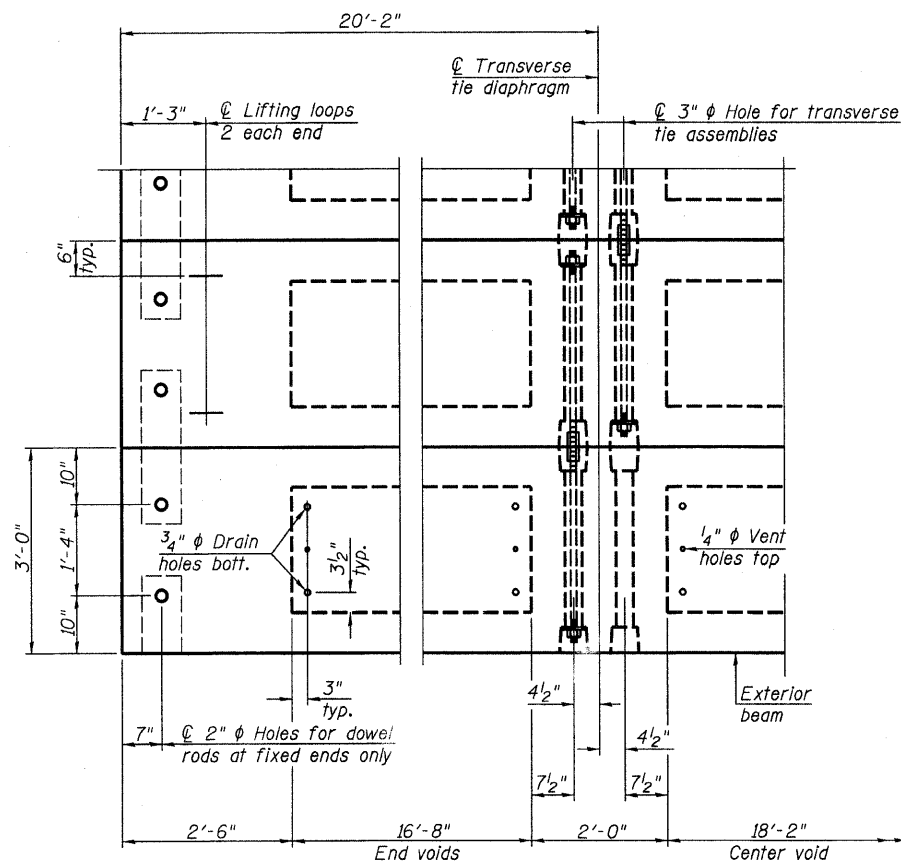

PLAN VIEW

Note: Connect beams in pairs with the transverse tie configuration shown.

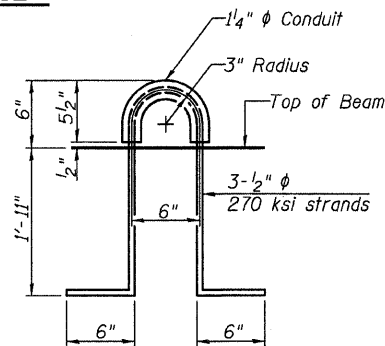

LIFTING LOOP DETAIL

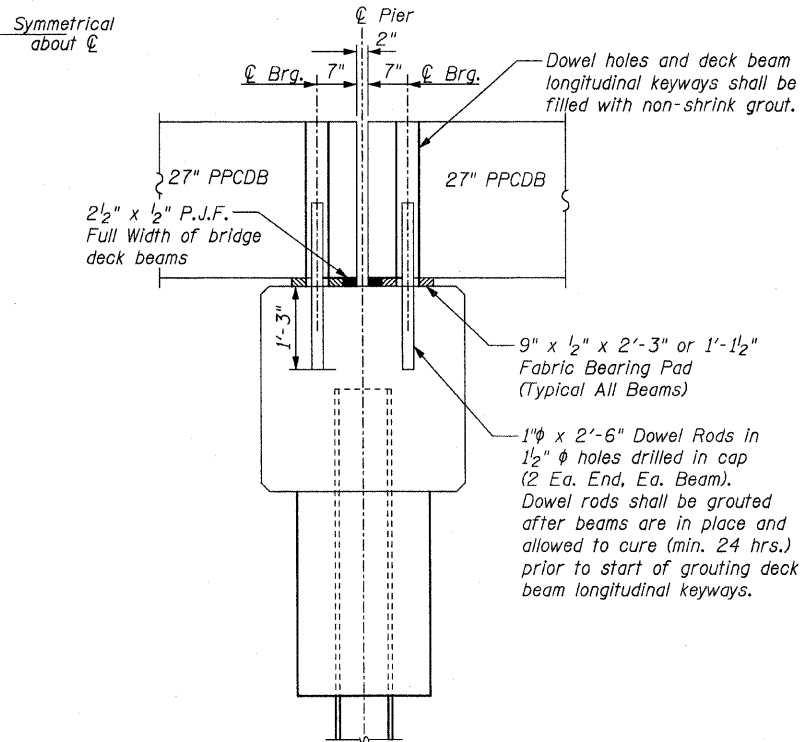

FIXED BEARING PIER

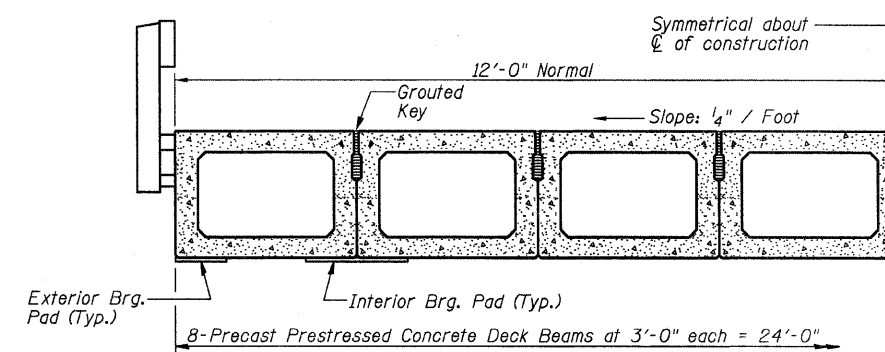

HALF CROSS SECTION

See Sheet 9 for the details showing the spacing and mounting of posts and rails to the PPCDB.

NOTES

- Prestressing steel shall be uncoated high strength, low relaxation 7-wire strand, Grade 270. The nominal diameter shall be 1/2" and the nominal cross-sectional area shall be 0.153 sq. in.
- The 1" phi rods in the transverse tie assembly shall be tightened to a snug fit and the threads set. Pockets on exterior faces of bridge shall be filled with grout after transverse tie assembly is in place.
- Reinforcement bars shall conform to ASTM A 706 (IL Modified), Grade 60.
- Two 1/8" fabric adjusting shims of the dimensions of the exterior bearing pad shall be provided for each bearing pad location.
- A minimum 2 1/2" phi lifting pin shall be used to engage the lifting loops during handling.
- Corrosion Inhibitor, per Article 1020.05(b)(12) and 1021.06 of the Standard Specifications, shall be used in the concrete for precast prestressed concrete deck beams.
- Compressive strength of prestressed concrete, f'c, shall be 6000 psi.
- Compressive strength of prestressed concrete at release, f'ci, shall be 5000 psi.

BILL OF MATERIAL

Precast Prestressed Conc. Deck Bms. (27" depth)	Sq. Ft.	2892*
---	---------	-------

* Total for 3 spans.

SPAN 2

DESIGNED - BLT	REVISED -
DRAWN - JN	REVISED -
CHECKED - WDL	REVISED -
DATE - 04/06/2012	REVISED -

ROUTE	SECTION	COUNTY	TOTAL SHEETS	SHEET NO.
TR 429	10-18121-00-BR	FAYETTE	15	8
CONTRACT NO. 95677				
RAAI JOB NO. 50811		ILLINOIS FED. AID PROJECT		