

F.A.S. NO.	SECTION	COUNTY	TOTAL SHEETS	SHEET NO.
1517 (2)RS-3 & (3)RS-4		MCLEAN	223	1
FED. ROAD DIST. NO. - ILLINOIS		FED. AID PROJECT		
P-93-022-00		D-93-057-03		

STATE OF ILLINOIS
DEPARTMENT OF TRANSPORTATION
DIVISION OF HIGHWAYS
**PLANS FOR PROPOSED
FEDERAL AID HIGHWAY**

FOR INDEX OF SHEETS, SEE SHEET NO. 2
FOR LIST OF HIGHWAY STANDARDS, SEE SHEET NO. 2

F.A.S. 1517 (U.S. ROUTE 150)
SECTION: (2)RS-3 & (3)RS-4
PROJECT NO. RS-1517 (110)
MCLEAN COUNTY

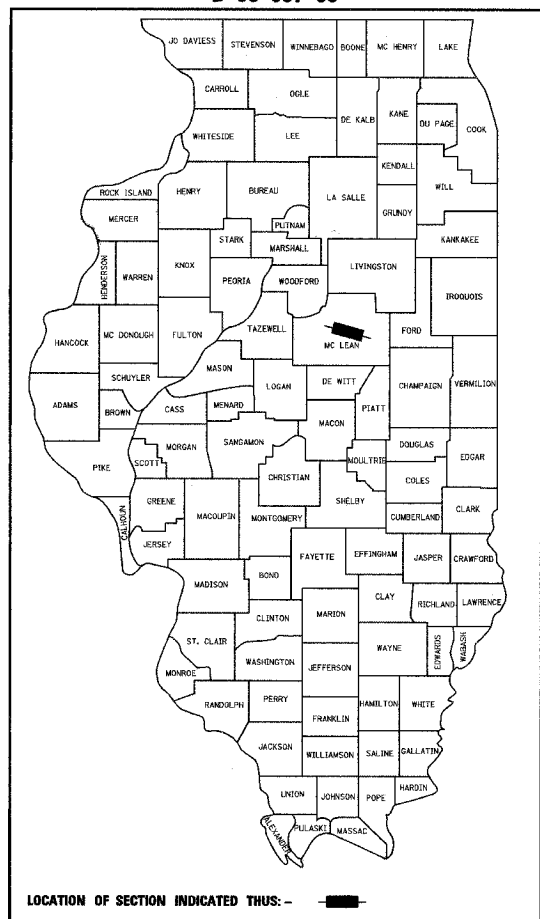

C-93-154-03
RESURFACING, GRADING AND SHOULDERS FROM THE EAST ABUTMENT OF THE
KICKAPOO CREEK BRIDGE NEAR DOWNS TO NORTH HEMLOCK STREET IN LEROY

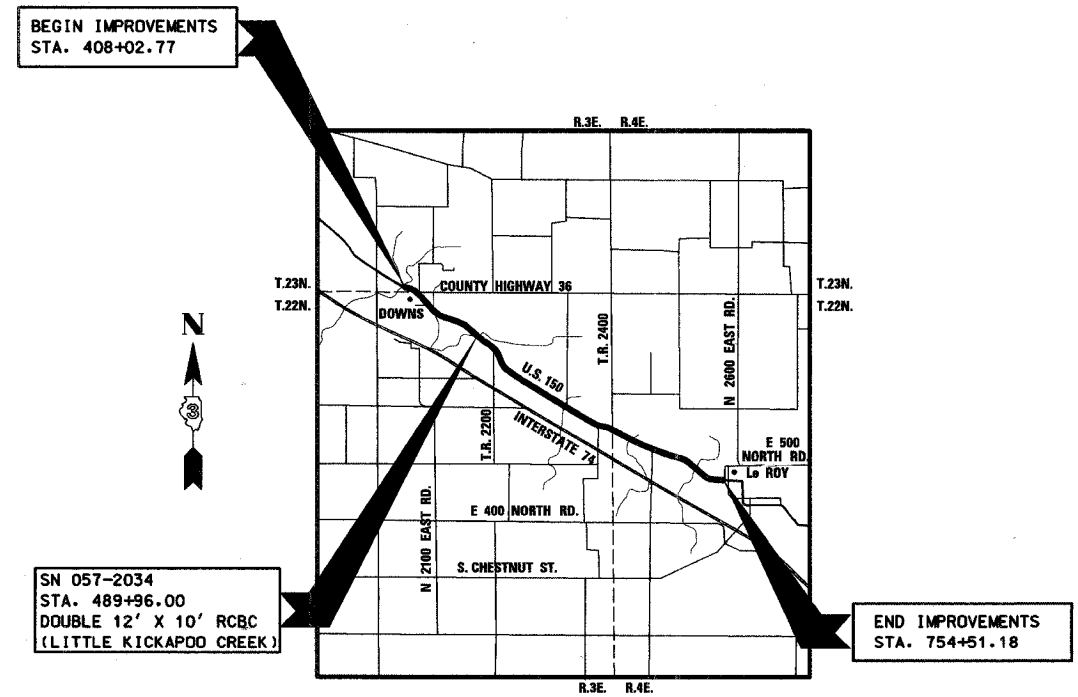
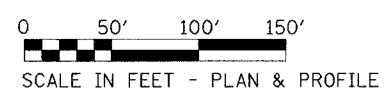

BEGIN IMPROVEMENTS
STA. 408+02.77

END IMPROVEMENTS
STA. 754+51.18

SN 057-2034
STA. 489+96.00
DOUBLE 12' X 10' RCBC
(LITTLE KICKAPOO CREEK)

LOCATION MAP
NOT TO SCALE

GROSS LENGTH = 34,648 FT. = 6.56 MI.
NET LENGTH = 34,648 FT. = 6.56 MI.

FULL SIZE PLANS HAVE BEEN PREPARED USING STANDARD
ENGINEERING SCALES, REDUCED SIZED PLANS WILL NOT
CONFORM TO STANDARD SCALES, IN MAKING MEASUREMENTS
ON REDUCED PLANS, THE ABOVE SCALES MAY BE USED.

MICROFILMED _____
REEL NUMBER _____
AWARDED _____
RESIDENT ENGINEER _____
AS BUILT CHANGES WERE MADE
ON THE FOLLOWING SHEETS _____

JULIE 1-800-892-0123

DISTRICT 3 NO. (815) 434-6131

PROJECT ENGINEER: DAN DRAPER
UNIT CHIEF: MICHELE LINDEMANN
TOWNSHIP: EMPIRE, DOWNS

CONTRACT NO. 66383

FUNCTIONAL CLASSIFICATION
RURAL MAJOR COLLECTOR - CLASS II TRUCK ROUTE
2003 ADT = 3150
P.V. = 89.2% S.U. = 5.4% M.U. = 5.4%

STATE OF ILLINOIS
DEPARTMENT OF TRANSPORTATION
DIVISION OF HIGHWAYS

SUBMITTED FEB 9 2006

Gregory Mout
DEPUTY DIRECTOR OF HIGHWAYS, REGION ENGINEER

Mike Hine
ENGINEER OF DESIGN AND ENVIRONMENT

Melton R. Snow, P.E.
DIRECTOR OF HIGHWAYS, CHIEF ENGINEER

Andrew Svihra
ANDREW SVIHRA
NO. 062-028196
EXP. DATE NOVEMBER 30, 2007
SMITH ENGINEERING CONSULTANTS, INC.

PRINTED BY THE AUTHORITY
OF THE STATE OF ILLINOIS

F.A.S. RTE.	SECTION	COUNTY	TOTAL SHEETS	SHEET NO.
1517 (2)RS-3 (3)RS-4		MCLEAN	223	2
STA. _____ TO STA. _____				
FED. ROAD DIST. NO. _____ ILLINOIS			FED. AID PROJECT	

66383

INDEX OF SHEETS

1	COVER SHEET
2	INDEX OF SHEETS / LIST OF STANDARDS
3	GENERAL NOTES
4-5	SUMMARY OF QUANTITIES
6-12	TYPICAL SECTIONS
13-18	SUPERELEVATION TRANSITION DETAILS
19-23	SCHEDULE OF QUANTITIES
24-25	PAVEMENT SCHEDULE
26	PATCHING SCHEDULE
27	DRIVEWAY SCHEDULE
28-30	STORM SEWER AND CULVERT SCHEDULE
31	TREE REMOVAL SCHEDULE / EARTHWORK SCHEDULE
32	PAVEMENT MARKING SCHEDULE
33-34	SIGN SCHEDULE
35-38	TIE POINTS
39	CONSTRUCTION STAGING / MAINTENANCE OF TRAFFIC PLAN
40-72	PLAN AND PROFILES
73-75	STORM SEWER PLAN AND PROFILES
76-88	EROSION CONTROL PLANS
89-97	INTERSECTION PAVEMENT ELEVATION PLANS
98-99	BOX CULVERT PLANS (STA. 442+60)
100-107	MISCELLANEOUS DETAILS
108-132	RIGHT-OF-WAY PLANS (BY OTHERS)
133-209	CROSS-SECTIONS (U.S. ROUTE 150)
210	CROSS-SECTIONS (SEMINARY STREET)
211-213	CROSS-SECTIONS (C.H. 36 - NORTH)
214-217	CROSS-SECTIONS (T.R. 2075)
218	CROSS-SECTIONS (C.H. 36 - SOUTH)
219	CROSS-SECTIONS (T.R. 2200)
220	CROSS-SECTIONS (T.R. 2325)
221	CROSS-SECTIONS (T.R. 2375)
222	CROSS-SECTIONS (T.R. 2400)
223	CROSS-SECTIONS (T.R. 2450)

LIST OF STANDARDS

280001-02	TEMPORARY EROSION CONTROL SYSTEMS
406201	MAILBOX TURNOUT
442201-01	CLASS C AND D PATCHES
482001	BITUMINOUS SHOULDER ADJACENT TO FLEXIBLE PAVEMENT
482011-01	BIT. SHOULDER STRIPS/SHOULDERS WITH RESURFACING OR WIDENING AND RESURFACING PROJECTS
542401	METAL END SECTION FOR PIPE CULVERTS
542406	METAL END SECTION FOR PIPE ARCHES
602301-01	INLET - TYPE A
602306-01	INLET - TYPE B
602401-01	MANHOLE - TYPE A
602701-01	CAST IRON STEPS
604001-02	FRAME AND LIDS, TYPE 1
604006-02	FRAME AND GRATE, TYPE 3
604036-01	GRATE, TYPE 8
604091-01	FRAME AND GRATE, TYPE 24
606001-02	CONCRETE CURB TYPE B AND COMBINATION CONCRETE CURB AND GUTTER
606006	OUTLET FOR CONCRETE CURB AND GUTTER TYPE B-15.60 (B-6.24)
630001-06	STEEL PLATE BEAM GUARDRAIL
631032-02	TRAFFIC BARRIER TERMINAL, TYPE 6A
635001	DELINEATORS
635006-02	REFLECTOR AND TERMINAL MARKER PLACEMENT
635011-01	REFLECTOR MARKER AND MOUNTING DETAILS
666001	RIGHT-OF-WAY MARKERS
667101	PERMANENT SURVEY MARKERS
668001	METHOD OF RESETTING U.S. GEOLOGICAL SURVEY AND NATIONAL GEODETIC SURVEY BENCHMARKS
701001-01	OFF-ROAD OPERATIONS 2L, 2W, MORE THAN 4.5m (15') AWAY
701006-02	OFF-ROAD OPERATIONS 2L, 2W, 4.5m (15') TO 600mm (24") FROM PAVEMENT EDGE
701011-01	OFF-ROAD MOVING OPERATIONS 2L, 2W, DAY ONLY
701201-02	LANE CLOSURE 2L, 2W, DAY ONLY, FOR SPEEDS ≥ 45 MPH
701301-02	LANE CLOSURE 2L, 2W, SHORT TIME OPERATIONS
701306-01	LANE CLOSURE 2L, 2W, SLOW MOVING OPERATIONS DAY ONLY, FOR SPEEDS ≥ 45 MPH
701311-02	LANE CLOSURE 2L, 2W, MOVING OPERATIONS - DAY ONLY
702001-06	TRAFFIC CONTROL DEVICES
720001	SIGN PANEL MOUNTING DETAILS
720006	SIGN PANEL ERECTION DETAILS
720011	METAL POSTS FOR SIGNS, MARKERS & DELINEATORS
729001	APPLICATIONS OF TYPES A AND B METAL (FOR SIGNS AND MARKERS)
780001-01	TYPICAL PAVEMENT MARKINGS
781001-02	TYPICAL APPLICATIONS RAISED REFLECTIVE PAVEMENT MARKERS

PLAN	DATE
BY	
SURVEYED	
PLANNED	
DESIGNED	
CHECKED	
BY	
DATE	
NO. OF MAY CHECKED	
ADD FILE NAME	
NOTE BOOK NO.	

PROFILE	DATE
BY	
SURVEYED	
PLANNED	
DESIGNED	
CHECKED	
BY	
DATE	
NO. OF MAY CHECKED	
ADD FILE NAME	
NOTE BOOK NO.	

COMPANY NAME: #COMPANY NAME#
 PROJECT CONTACT: #PROJECT CONTACT#
 CLIENT: #CLIENT#
 DATE: #DATE#
 TIME: #TIME#
 FILE: #FILE#

ILLINOIS DEPARTMENT OF TRANSPORTATION
 F.A.S. 1517 (U.S. ROUTE 150)

INDEX OF SHEETS LIST OF STANDARDS

SCALE: VERT.
 HORIZ.
 DATE

DRAWN BY
 CHECKED BY

GENERAL NOTES

THE THICKNESS OF BITUMINOUS MIXTURES SHOWN ON THE PLANS IS THE NOMINAL THICKNESS. DEVIATIONS FROM THE NOMINAL THICKNESS WILL BE PERMITTED WHEN SUCH DEVIATIONS OCCUR DUE TO IRREGULARITIES IN THE EXISTING SURFACE OR BASE ON WHICH THE BITUMINOUS MIXTURE IS PLACED.

THE BITUMINOUS SURFACE OF ALL MAILBOX TURNOUTS, PRIVATE ENTRANCES, COMMERCIAL ENTRANCES, AND SIDE ROADS SHALL BE MADE NEATLY, IN A WORKMANLIKE MANNER, AND SHALL ACCURATELY CONFORM TO THE SHAPES AND DIMENSIONS SHOWN ON THE PLAN DETAILS. IF REQUIRED BY THE ENGINEER, THE CONTRACTOR SHALL BE REQUIRED TO SAW CUT THE BITUMINOUS SURFACE TO CONFORM TO THE SHAPES AND DIMENSIONS SHOWN ON THE PLAN DETAILS. THIS WORK SHALL BE INCLUDED IN THE COST OF THE BITUMINOUS SURFACE.

THE BASE COURSE WIDENING SHALL BE CARRIED THROUGH ALL ENTRANCES, SIDE ROADS, AND MAILBOX TURNOUTS. EXCEPTIONS WILL BE SHOWN ON THE PLANS.

EXCEPT AS NOTED ON THE PLANS, PAVEMENT GRADES SHOWN ARE AT THE TOP OF PAVEMENT SURFACES.

BEFORE ORDERING PIPE CULVERTS OR PIPE DRAINS, THE CONTRACTOR SHALL CONSULT THE ENGINEER FOR EXACT LENGTHS.

ESTIMATED QUANTITIES OF EXPLORATION TRENCH, STORM SEWER SPECIAL, AND FIELD TILE JUNCTION VAULTS HAVE BEEN INCLUDED IN THE PLANS. THESE ITEMS ARE NOT SCHEDULED. EXACT LOCATIONS FOR THESE ITEMS SHALL BE DETERMINED BY THE ENGINEER.

AGGREGATE (PRIME COAT): FA 20 MAY BE USED IN ADDITION TO THE GRADATIONS LISTED IN THE 3RD PARAGRAPH OF ARTICLE 1003.03(g) OF THE STANDARD SPECIFICATIONS.

THE ENGINEER WILL BE THE SOLE JUDGE CONCERNING CURING TIME FOR THE VARIOUS BITUMINOUS LIFTS.

FOR STABILIZATION, ALL TYPE III BARRICADES SHALL REQUIRE A MINIMUM OF FOUR SAND BAGS PER BARRICADE.

WHERE SECTION OR SUBSECTION MONUMENTS ARE ENCOUNTERED, THE ENGINEER SHALL BE NOTIFIED BEFORE SUCH MONUMENTS ARE REMOVED. THE CONTRACTOR SHALL PROTECT AND CAREFULLY PRESERVE ALL MONUMENTS UNTIL AN AUTHORIZED SURVEYOR OR AGENT HAS WITNESSED OR OTHERWISE REFERENCED THEIR LOCATION. THE CONTRACTOR SHALL BE RESPONSIBLE FOR HAVING AN AUTHORIZED SURVEYOR REESTABLISH ANY SECTION OR SUBSECTION MONUMENTS DESTROYED BY HIS OPERATIONS.

SEEDING SHALL NOT BE PERMITTED AT ANY TIME WHEN THE GROUND IS FROZEN, WET, OR IN AN UNTILLABLE CONDITION. LOCATIONS TO BE SEEDED WILL BE DETERMINED BY THE ENGINEER.

ONLY THOSE TREES DESIGNATED BY THE ENGINEER OR LISTED IN THE TREE REMOVAL SCHEDULE SHALL BE REMOVED. THE CONTRACTOR SHALL PROTECT ALL REMAINING TREES FROM DAMAGE DUE TO HIS OPERATIONS.

THE FINISHED EARTHWORK SHALL HAVE A VEGETATION SUSTAINING SOIL COVERING THE TOP FOUR INCHES IN ALL AREAS TO BE SEEDED. THE VEGETATION SUSTAINING SOIL REQUIRED WILL NOT BE PAID FOR SEPARATELY, BUT SHALL BE INCLUDED IN THE COST OF EARTH EXCAVATION.

ALL ELEVATIONS REFER TO THE U.S.G.S. MEAN SEA LEVEL DATUM.

ABANDONED UNDERGROUND UTILITIES THAT CONFLICT WITH CONSTRUCTION SHALL BE DISPOSED OF OUTSIDE THE LIMITS OF THE RIGHT OF WAY ACCORDING TO ARTICLE 202.03 OF THE STANDARD SPECIFICATIONS AND AS DIRECTED BY THE ENGINEER. THIS WORK WILL NOT BE PAID FOR SEPARATELY BUT SHALL BE INCLUDED IN THE COST OF EARTH EXCAVATION.

ANY REFERENCE TO A STANDARD IN THESE PLANS SHALL BE INTERPRETED TO MEAN THE EDITION AS INDICATED BY THE SUBNUMBER LISTED ON THE INDEX OF SHEETS OR THE COPY OF THE STANDARD INCLUDED IN THESE PLANS.

THE FOLLOWING RATES OF APPLICATION HAVE BEEN USED IN CALCULATING PLAN QUANTITIES:

GRANULAR MATERIALS	2.05	TONS / CU YD
BITUMINOUS MAT PRIME COAT	0.08	GAL / SQ YD OR
	0.375	GAL / SQ YD
AGGREGATE PRIME COAT	0.002	TONS / SQ YD
BITUMINOUS RESURFACING	112	LBS / SQ YD / IN
SHORT TERM PAVEMENT MARKING	10	FT / 100 FT OF APPLICATION
TEMPORARY DITCH CHECKS	9	BALES OR
	5	TONS AGGREGATE

THE CONTRACTOR SHALL BE RESPONSIBLE FOR PROTECTING UTILITY PROPERTY DURING CONSTRUCTION OPERATIONS AS OUTLINED IN ARTICLE 107.31 OF THE STANDARD SPECIFICATIONS. A MINIMUM OF 48 HOURS ADVANCE NOTICE IS REQUIRED FOR NON-EMERGENCY WORK. THE JULIE NUMBER IS 800-892-0123. THE FOLLOWING LISTED UTILITIES LOCATED WITHIN PROJECT LIMITS OR IMMEDIATELY ADJACENT TO PROJECT LIMITS ARE MEMBERS OF JULIE:

NICOR GAS COMPANY
1844 FERRY ROAD
NAPERVILLE, ILLINOIS 60563

VERIZON
1312 EAST EMPIRE STREET
BLOOMINGTON, ILLINOIS 61701

AMEREN IP
501 EAST LAFAYETTE STREET
BLOOMINGTON, ILLINOIS 61702

CORN BELT ENERGY
ONE ENERGY WAY
BLOOMINGTON, ILLINOIS 61704

MEDIACOM
1102 NORTH FOURTH STREET
CHILLICOTHE, ILLINOIS 61523

MAGELLAN MIDSTREAM PARTNERS
13424 WEST 98TH STREET
SHAWNEE MISSION, KANSAS 66215

THE FOLLOWING LISTED UTILITIES LOCATED WITHIN PROJECT LIMITS OR IMMEDIATELY ADJACENT TO PROJECT LIMITS ARE NON-MEMBERS OF JULIE:

VILLAGE OF DOWNS
211 S. SEMINARY
DOWNS, ILLINOIS 61736

COMMITMENTS:

- ENVIRONMENTAL COORDINATION.
- THE CONTRACTOR SHALL BE AWARE OF THE PRESENCE OF A SEPTIC SYSTEM IN THE PROXIMITY OF THE TEMPORARY EASEMENT IN THE SOUTHWEST QUADRANT OF THE WASHINGTON STREET INTERSECTION. CARE IS TO BE USED WHEN WORKING WITHIN THE TEMPORARY CONSTRUCTION EASEMENT SO AS NOT TO DAMAGE THE SEPTIC SYSTEM.
- DURING NEGOTIATIONS, A COMMITMENT WAS MADE TO RELOCATE THE EXISTING TURN AROUND OUTSIDE OF THE PROPOSED RIGHT-OF-WAY AREA AT STATION 695+52 LT. A TEMPORARY USE PERMIT WILL BE SECURED BY THE LAND ACQUISITION SECTION.

PLAN	DATE
BY	
SURVEYED	
ALIGNED	
CHECKED	
NOTE BOOK	
NO.	

PROFILE	DATE
BY	
SURVEYED	
GRADES	
CHECKED	
NOTE BOOK	
NO.	

COMPANY NAME: #COMPANY NAME
PROJECT CONTACT: #PROJECT CONTACT #
CLIENT: #CLIENT #
DATER: #DATER #
FILE #

STATE OF ILLINOIS
DEPARTMENT OF TRANSPORTATION
DISTRICT THREE

REVIEWED BY: *Rich Powell*
DISTRICT STUDIES AND PLANS ENGINEER

DATE: 2/9/06

EXAMINED BY: *Robert J. [Signature]*
DISTRICT CONSTRUCTION ENGINEER

Kenneth R. Lane
DISTRICT MATERIALS ENGINEER

James A. [Signature]
DISTRICT OPERATIONS ENGINEER

ILLINOIS DEPARTMENT OF TRANSPORTATION
F.A.S. 1517 (U.S. ROUTE 150)

GENERAL NOTES

SCALE: VERT.
DATE: _____

HORIZ.
DRAWN BY
CHECKED BY

COMPANY NAME: #COMPANY NAME#
 PROJECT CONTACT: #PROJECT CONTACT#
 CLIENT: #CLIENT#
 #DAYS #HOURS #MINUTES #SECONDS

PROF. FILE SURVEYED _____ BY _____ DATE _____
 NOTE BOOK GRADES CHECKED _____
 PLAN NOTED INSTRUCTIONS CHNG _____
 NO. _____

PLAN SURVEYED _____ BY _____ DATE _____
 NOTE BOOK GRADES CHECKED _____
 PLAN NOTED INSTRUCTIONS CHNG _____
 NO. _____

80% F&P
 20% STATE

CODE NUMBER	PAY ITEMS	UNIT	TOTAL QUANTITY	1000-2A	SFTY-2A
20100110	TREE REMOVAL (6 TO 15 UNITS DIAMETER)	UNIT	288	288	
20100210	TREE REMOVAL (OVER 15 UNITS DIAMETER)	UNIT	559	559	
20200100	EARTH EXCAVATION	CU YD	79371	79371	
20700110	POROUS GRANULAR EMBANKMENT	TON	1015	1015	
20800150	TRENCH BACKFILL	CU YD	883	883	
21301062	EXPLORATION TRENCH 82" DEPTH	FOOT	49500	49500	
25000100	SEEDING, CLASS 1	ACRE	7.2	7.2	
25000200	SEEDING, CLASS 2	ACRE	33.4	33.4	
25000400	NITROGEN FERTILIZER NUTRIENT	POUND	3008	3008	
25000500	PHOSPHORUS FERTILIZER NUTRIENT	POUND	3006	3006	
25000600	POTASSIUM FERTILIZER NUTRIENT	POUND	3006	3006	
25100115	MULCH, METHOD 2	ACRE	40.6	40.6	
25100630	EROSION CONTROL BLANKET	SQ YD	2348	2348	
28000250	TEMPORARY EROSION CONTROL SEEDING	POUND	20300	20300	
28000300	TEMPORARY DITCH CHECKS	EACH	286	286	
28000400	PERIMETER EROSION BARRIER	FOOT	4800	4800	
28000500	INLET AND PIPE PROTECTION	EACH	100	100	
28100607	STONE DUMPED RIPRAP, CLASS A4	TON	1101	1101	
28200200	FILTER FABRIC	SQ YD	1209	1209	
31100300	SUB-BASE GRANULAR MATERIAL, TYPE A 4"	SQ YD	12462	12462	
31102100	SUB-BASE GRANULAR MATERIAL, TYPE C 4"	SQ YD	28404	28380	24
35102000	AGGREGATE BASE COURSE, TYPE B 8"	SQ YD	2515	2515	
40200800	AGGREGATE SURFACE COURSE, TYPE B	TON	1989	1989	
40600100	BITUMINOUS MATERIALS (PRIME COAT)	GAL	10275	10269	6
40600300	AGGREGATE (PRIME COAT)	TON	188.4	188.2	0.2
40600865	CONSTRUCTING TEST STRIP	EACH	2	2	
40600980	BITUMINOUS SURFACE REMOVAL - BUTT JOINT	SQ YD	728	728	
40600990	TEMPORARY RAMP	SQ YD	114	114	
40600040	INCIDENTAL BITUMINOUS SURFACING	TON	254	254	
42300200	PORTLAND CEMENT CONCRETE DRIVEWAY PAVEMENT, 6"	SQ YD	154	154	
44000030	BITUMINOUS SURFACE REMOVAL (VARIABLE DEPTH)	SQ YD	82959	82883	76
44000100	PAVEMENT REMOVAL	SQ YD	3902	3902	
44000200	DRIVEWAY PAVEMENT REMOVAL	SQ YD	1636	1636	
44000500	COMBINATION CONCRETE CURB AND GUTTER REMOVAL	FOOT	2245	2245	
44001430	BITUMINOUS SHOULDER REMOVAL	SQ YD	12612	12568	14
44201765	CLASS D PATCHES, TYPE II, 10 INCH	SQ YD	979	979	
44201768	CLASS D PATCHES, TYPE III, 10 INCH	SQ YD	386	386	
44201771	CLASS D PATCHES, TYPE IV, 10 INCH	SQ YD	1195	1195	
48101200	AGGREGATE SHOULDERS, TYPE B	TON	11771	11759	12
48202410	BITUMINOUS SHOULDERS SUPERPAVE 6 1/2"	SQ YD	22730	22709	21
50106200	REMOVE EXISTING CULVERTS	EACH	64	64	
50800105	REINFORCEMENT BARS	POUND	5310	5310	
54001002	BOX CULVERT END SECTION, CULVERT NO. 2	EACH	2	2	
54001003	BOX CULVERT END SECTION, CULVERT NO. 3	EACH	2	2	
54001004	BOX CULVERT END SECTION, CULVERT NO. 4	EACH	2	2	
54001005	BOX CULVERT END SECTION, CULVERT NO. 5	EACH	2	2	
54001006	BOX CULVERT END SECTION, CULVERT NO. 6	EACH	2	2	
54003000	CONCRETE BOX CULVERTS	CU YD	24	24	
54010503	PRECAST CONCRETE BOX CULVERT 6' X 3'	FOOT	84.0	84.0	
54010904	PRECAST CONCRETE BOX CULVERT 9' X 4'	FOOT	102.0	102.0	
54011004	PRECAST CONCRETE BOX CULVERT 10' X 4'	FOOT	54.0	54.0	
542A0223	PIPE CULVERTS, CLASS A, TYPE 1, 18"	FOOT	440	440	
542D0223	PIPE CULVERTS, CLASS D, TYPE 1, 18"	FOOT	1986	1986	
542D0229	PIPE CULVERTS, CLASS D, TYPE 1, 24"	FOOT	195	195	
542D0235	PIPE CULVERTS, CLASS D, TYPE 1, 30"	FOOT	60	60	
542D5473	PIPE CULVERTS, CLASS D, TYPE 1 EQUIVALENT ROUND-SIZE 18"	FOOT	170	170	
542D5465	PIPE CULVERTS, CLASS D, TYPE 1 EQUIVALENT ROUND-SIZE 30"	FOOT	52	52	
54207573	PIPE CULVERTS, TYPE 1, REINFORCED CONCRETE - ARCH, EQUIVALENT ROUND - SIZE 18"	FOOT	326	326	
54207581	PIPE CULVERTS, TYPE 1, REINFORCED CONCRETE - ARCH, EQUIVALENT ROUND - SIZE 36"	FOOT	219	219	
54213463	END SECTIONS 18"	EACH	76	76	
54213459	END SECTIONS 24"	EACH	6	6	
54213465	END SECTIONS 30"	EACH	2	2	
54213657	PRECAST REINFORCED CONCRETE FLARED END SECTIONS 12"	EACH	5	5	
54213663	PRECAST REINFORCED CONCRETE FLARED END SECTIONS 18"	EACH	12	12	
54213669	PRECAST REINFORCED CONCRETE FLARED END SECTIONS 24"	EACH	2	2	
54214293	END SECTIONS, EQUIVALENT ROUND-SIZE 18"	EACH	8	8	
54214305	END SECTIONS, EQUIVALENT ROUND-SIZE 30"	EACH	2	2	

* SPECIALTY ITEM

ILLINOIS DEPARTMENT OF TRANSPORTATION
 F.A.S. 1517 (U.S. ROUTE 150)
 SUMMARY OF QUANTITIES
 (SHEET 1 OF 2)

SCALE: VERT. _____
 HORIZ. _____
 DATE _____

DRAWN BY _____
 CHECKED BY _____

F.A.S. RTE.	SECTION	COUNTY	TOTAL SHEETS	SHEET NO.
1517 (2)RS-3	(3)RS-4	MCLEAN	223	4
STA.		TO STA.		
FED. ROAD DIST. NO.		ILLINOIS FED. AID PROJECT		

COMPANY NAME: #COMPANY NAME#
 PROJECT CONTACT: #PROJECT CONTACT#
 CLIENT: #CLIENT#
 DATE: #DATE#
 TIME: #TIME#
 FILES

PROFILE SURVEYED PLOTTED CHECKED
 NOTE BOOK PLAN NOTED
 NO. STRUCTURE NOTATIONS CHG'D
 BY: DATE

PLAN SURVEYED PLOTTED CHECKED
 NOTE BOOK PLAN NOTED
 NO. CAD FILE NAME
 BY: DATE

← 80% FID 20% STAYE →

CODE NUMBER	PAY ITEMS	UNIT	TOTAL QUANTITY	1000-2A	SFTY-2A
54214923	PRECAST REINFORCED CONCRETE FLARED END SECTIONS - ARCH. EQUIVALENT ROUND-SIZE 18"	EACH	6	6	
54214941	PRECAST REINFORCED CONCRETE FLARED END SECTIONS - ARCH. EQUIVALENT ROUND-SIZE 36"	EACH	8	8	
54247130	GRATING FOR CONCRETE FLARED END SECTION 24"	EACH	2	2	
54248160	GRATING FOR CONCRETE FLARED END SECTION EQUIVALENT ROUND-SIZE 36"	EACH	8	8	
550A0050	STORM SEWERS, CLASS A, TYPE 1, 12"	FOOT	771	771	
550A0070	STORM SEWERS, CLASS A, TYPE 1, 15"	FOOT	500	500	
550A0090	STORM SEWERS, CLASS A, TYPE 1, 18"	FOOT	698	698	
550A0120	STORM SEWERS, CLASS A, TYPE 1, 24"	FOOT	108	108	
60218400	MANHOLES, TYPE A, 4-DIAMETER, TYPE 1 FRAME, CLOSED LID	EACH	7	7	
60220230	MANHOLES, TYPE A, 4-DIAMETER, SPECIAL FRAME AND GRATE	EACH	6	6	
60235700	INLETS, TYPE A, TYPE 3 FRAME AND GRATE	EACH	2	2	
60236200	INLETS, TYPE A, TYPE 8 GRATE	EACH	2	2	
60238700	INLETS, TYPE A, WITH SPECIAL FRAME AND GRATE	EACH	12	12	
60240301	INLETS, TYPE B, TYPE 8 GRATE	EACH	1	1	
60240385	INLETS, TYPE B, WITH SPECIAL FRAME AND GRATE	EACH	10	10	
60255500	MANHOLES TO BE ADJUSTED	EACH	1	1	
60500050	REMOVING CATCH BASINS	EACH	2	2	
60500060	REMOVING INLETS	EACH	2	2	
60605000	COMBINATION CONCRETE CURB AND GUTTER, TYPE B-G-24	FOOT	6858	6858	
61133100	FIELD TILE JUNCTION VAULTS, 2' DIA.	EACH	60	60	
61139800	STORM SEWERS, SPECIAL 4"	FOOT	600	600	
61139900	STORM SEWERS, SPECIAL 6"	FOOT	600	600	
61140000	STORM SEWERS, SPECIAL 8"	FOOT	600	600	
61140100	STORM SEWERS, SPECIAL 10"	FOOT	600	600	
61140200	STORM SEWERS, SPECIAL 12"	FOOT	600	600	
63000005	STEEL PLATE BEAM GUARD RAIL, TYPE B	FOOT	100	100	
63100087	TRAFFIC BARRIER TERMINAL, TYPE 6A	EACH	2	2	
63100167	TRAFFIC BARRIER TERMINAL TYPE 1, SPECIAL (TANGENT)	EACH	1	1	
63100169	TRAFFIC BARRIER TERMINAL TYPE 1, SPECIAL (FLARED)	EACH	1	1	
63200310	GUARDRAIL REMOVAL	FOOT	163	163	
66400200	NON-SPECIAL WASTE DISPOSAL	CUYD	42	42	
66600105	FURNISHING AND ERECTING RIGHT-OF-WAY MARKERS	EACH	166	166	
66900450	SPECIAL WASTE PLANS AND REPORTS	L SUM	1	1	
66700205	PERMANENT SURVEY MARKERS, TYPE 1	EACH	44	44	
66900530	SOIL DISPOSAL ANALYSIS	EACH	2	2	
67000400	ENGINEER'S FIELD OFFICE, TYPE A	CAL MO	12	12	
67100100	MOBILIZATION	L SUM	1	1	
70100450	TRAFFIC CONTROL AND PROTECTION, STANDARD 701201	L SUM	1	1	
70100460	TRAFFIC CONTROL AND PROTECTION, STANDARD 701306	L SUM	1	1	
70103815	TRAFFIC CONTROL SURVEILLANCE	CAL DA	20	20	
70300100	SHORT-TERM PAVEMENT MARKING	FOOT	10686	10686	
70300210	TEMPORARY PAVEMENT MARKING - LETTERS AND SYMBOLS	SQ FT	36	36	
70300220	TEMPORARY PAVEMENT MARKING - LINE 4"	FOOT	243843	243843	
70300240	TEMPORARY PAVEMENT MARKING - LINE 6"	FOOT	24060	24060	
70300250	TEMPORARY PAVEMENT MARKING - LINE 8"	FOOT	256	256	
70301000	WORK ZONE PAVEMENT MARKING REMOVAL	SQ FT	32430	32430	
72000100	SIGN PANEL - TYPE 1	SQ FT	372	372	
72000200	SIGN PANEL - TYPE 2	SQ FT	10	10	
72400600	RELOCATE SIGN PANEL ASSEMBLY - TYPE B	EACH	3	3	
72500100	OBJECT MARKER - TYPE 1	EACH	2	2	
73000100	WOOD SIGN SUPPORT	FOOT	1010	1010	
73502000	RELOCATE GROUND MOUNTED SIGN SUPPORT	EACH	16	16	
78000100	THERMOPLASTIC PAVEMENT MARKING - LETTERS AND SYMBOLS	SQ FT	36	36	
78000200	THERMOPLASTIC PAVEMENT MARKING - LINE 4"	FOOT	81281	81281	
78000400	THERMOPLASTIC PAVEMENT MARKING - LINE 6"	FOOT	8020	8020	
78000500	THERMOPLASTIC PAVEMENT MARKING - LINE 8"	FOOT	156	156	
78000650	THERMOPLASTIC PAVEMENT MARKING - LINE 24"	FOOT	281	281	
78100100	RAISED REFLECTIVE PAVEMENT MARKER	EACH	437	437	
78200410	GUARDRAIL MARKERS, TYPE A	EACH	10	10	
78201000	TERMINAL MARKER - DIRECT APPLIED	EACH	2	2	
78300200	RAISED REFLECTIVE PAVEMENT MARKER REMOVAL	EACH	450	450	
X3550215	BITUMINOUS BASE COURSE SUPERPAVE 5 3/4"	SQ YD	4921	4921	
X3560130	BITUMINOUS CONCRETE BASE COURSE WIDENING, SUPERPAVE 9 INCH	SQ YD	2266	2266	
X4066414	BITUMINOUS CONCRETE SURFACE COURSE, SUPERPAVE, MIX "C", N50	TON	9862	9854	8.0
X4066614	BITUMINOUS CONCRETE BINDER COURSE, SUPERPAVE, IL-19.0, N50	TON	621	621	
X4066765	LEVELING BINDER (MACHINE METHOD), SUPERPAVE N50	TON	8274	8268	6.0
X6063600	COMBINATION CONCRETE CURB AND GUTTER, TYPE M-4-24	FOOT	154	154	
Z0000980	AGGREGATE FOR TEMPORARY ACCESS	TON	2829	2829	
Z0064225	SEALING ABANDONED WATER WELLS	EACH	1	1	
X0325321	PRECAST CONCRETE BOX CULVERT 6' X 2.5'	FOOT	54.0	54.0	
X0325331	PRECAST CONCRETE BOX CULVERT 8' X 3.5'	FOOT	54.0	54.0	

* SPECIALTY ITEM

F.A.S. RTE.	SECTION	COUNTY	TOTAL SHEETS	SHEET NO.
1517	(2)RS-3 (3)RS-4	MCLEAN	223	5
STA. TO STA.		ILLINOIS FED. AID PROJECT		

66383

ILLINOIS DEPARTMENT OF TRANSPORTATION
 F.A.S. 1517 (U.S. ROUTE 150)
 SUMMARY OF QUANTITIES
 (SHEET 2 OF 2)

SCALE: VERT. DATE
 HORIZ. DATE

DRAWN BY
 CHECKED BY

F.A.S. RTE.	SECTION	COUNTY	TOTAL SHEETS	SHEET NO.
1517 (2)RS-3 (3)RS-4		MCLEAN	223	6
STA. _____ TO STA. _____				
FED. ROAD DIST. NO. - ILLINOIS		FED. AID PROJECT		

66383

PLAN	DATE
BY	
SURVEYED	
ALIGNED	
CHECKED	
DATE	
FILE NAME	
NO.	

PROFILE	DATE
BY	
SURVEYED	
GRADES CHECKED	
DATE	
FILE NAME	
NO.	

COMPANY NAME: #COMPANY NAME#
 PROJECT CONTACT: #PROJECT CONTACT#
 CLIENT: #CLIENT#
 DATE: #DATE#
 SHEET: #SHEET#

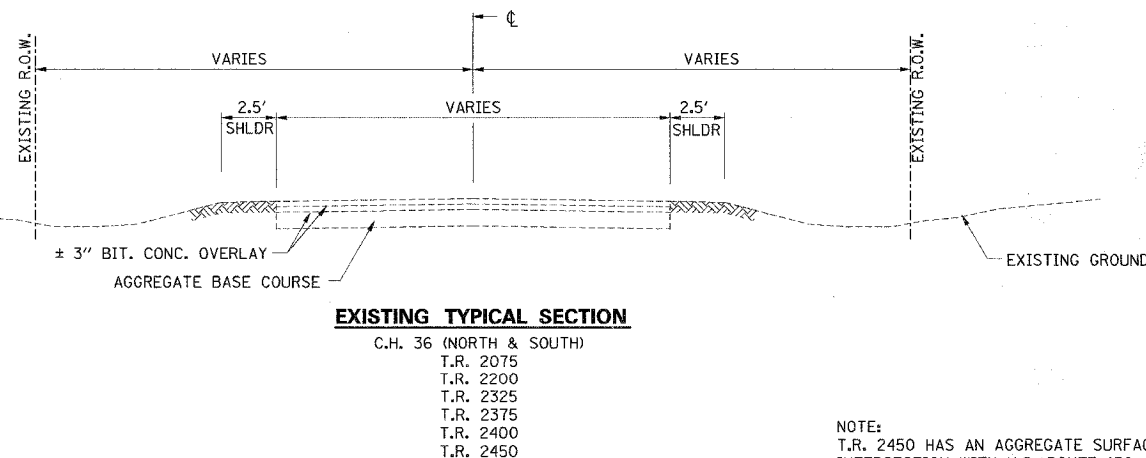
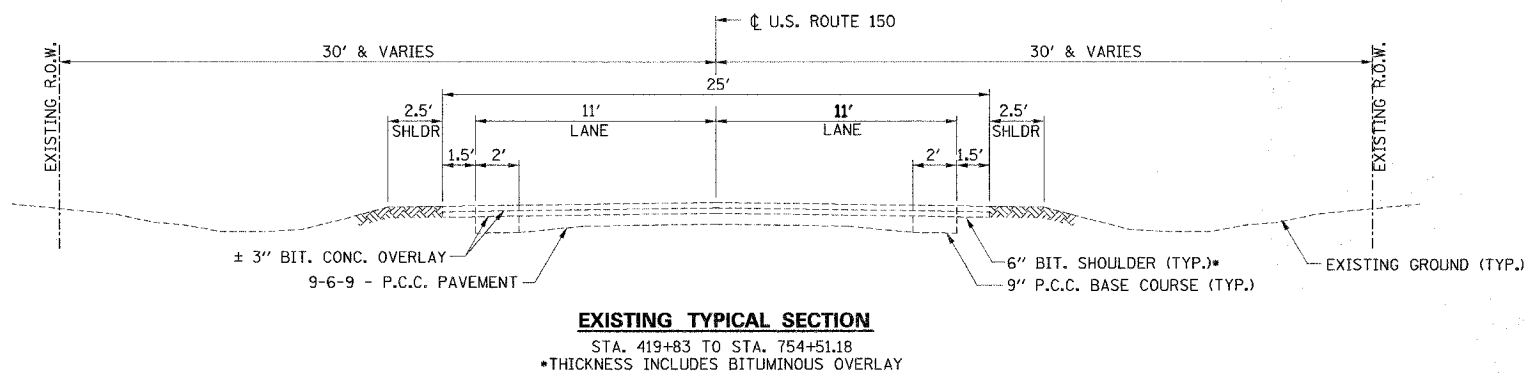
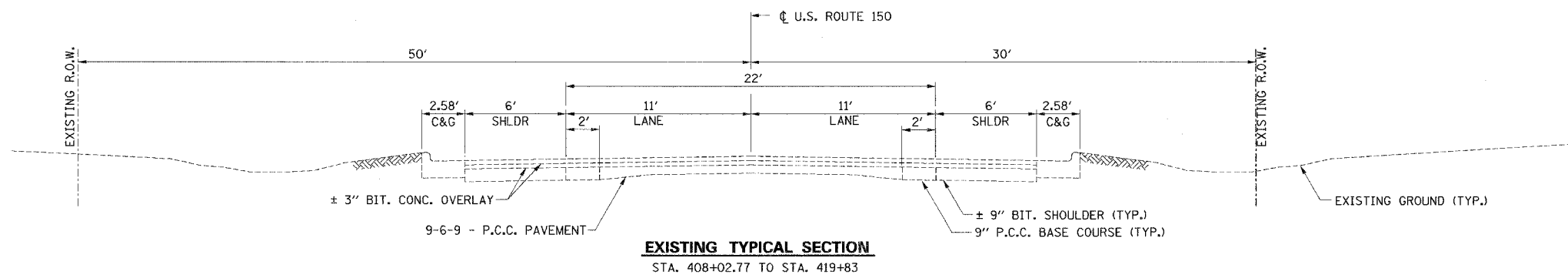

NOTE:
 T.R. 2450 HAS AN AGGREGATE SURFACE BEYOND THE
 INTERSECTION WITH U.S. ROUTE 150.

ILLINOIS DEPARTMENT OF TRANSPORTATION
F.A.S. 1517 (U.S. ROUTE 150)
EXISTING TYPICAL SECTIONS

SCALE: VERT. _____
 HORIZ. _____
 DATE _____

DRAWN BY _____
 CHECKED BY _____

MIX DESIGN

	SUPERPAVE BINDER	SUPERPAVE LEVEL BINDER	SUPERPAVE SURFACE	SUPERPAVE BASE COURSE	SUPERPAVE SHOULDERS
PG GRADE	PG64-22	PG64-22	PG64-22	PG64-22	PG58-22
MAX % RAP ALLOWABLE**	25%	25%	15%	25%	40%
DESIGN AIR VOIDS	4.0% @ N50	4.0% @ N50	4.0% @ N50	4.0% @ N50	2.0% @ N30
MIXTURE COMPOSITION	IL 19.0	IL 9.5	IL 12.5 OR IL 9.5	IL 19.0	BAM
FRICTION AGGREGATE			MIXTURE C		
PLANT CONTROL LIMITS	CLASS I	CLASS I	CLASS I	CLASS I	NON-CLASS I
DENSITY CONTROL METHOD	CORES/ CORRELATION	*	CORRELATION	*	*

* MATERIAL SHALL BE COMPACTED TO 93-97 PERCENT OF THE MAXIMUM THEORETICAL DENSITY, EXCEPT THAT THE BOTTOM LIFT SHALL BE COMPACTED TO A MINIMUM OF 91.0 PERCENT. THE MAXIMUM THEORETICAL DENSITY SHALL BE DETERMINED FROM THE MOVING AVERAGE AS SPECIFIED IN THE QC/QA SPECIFICATION.

** IF MORE THAN 15 PERCENT RAP IS USED IN THE SHOULDERS, BASE COURSE, BINDER AND LEVELING BINDER MIXES, THE GRADE OF ASPHALT CEMENT SHALL BE PG58-28.

NOTES:

STA. 437+43.00 TO STA. 438+84.82 - SUPERELEVATION TRANSITION.
 STA. 438+84.82 TO STA. 439+84.82 - LANE WIDTH TRANSITIONS FROM 13' TO 11'.

* BITUMINOUS LEVELING BINDER (MACHINE METHOD), SUPERPAVE N50 SHALL MEET THE SPECIFICATIONS OF BITUMINOUS CONCRETE BINDER COURSE, SUPERPAVE, IL-19.0, N50 WHEN LIFTS OF 2 1/4" OR MORE CAN BE PLACED. SEE SPECIAL PROVISIONS.

** BITUMINOUS SURFACE REMOVAL DEPTH SHALL BE 3/4" AT THE CENTERLINE. MILLED SURFACE SHALL MAINTAIN THE PROPOSED PAYEMENT CROSS-SLOPE AT THAT LOCATION. NO MILLING REQUIRED WHEN THE EXISTING CROSS-SLOPE ALLOWS FOR THE 3/4" MINIMUM THICKNESS OF LEVELING BINDER TO BE PLACED.

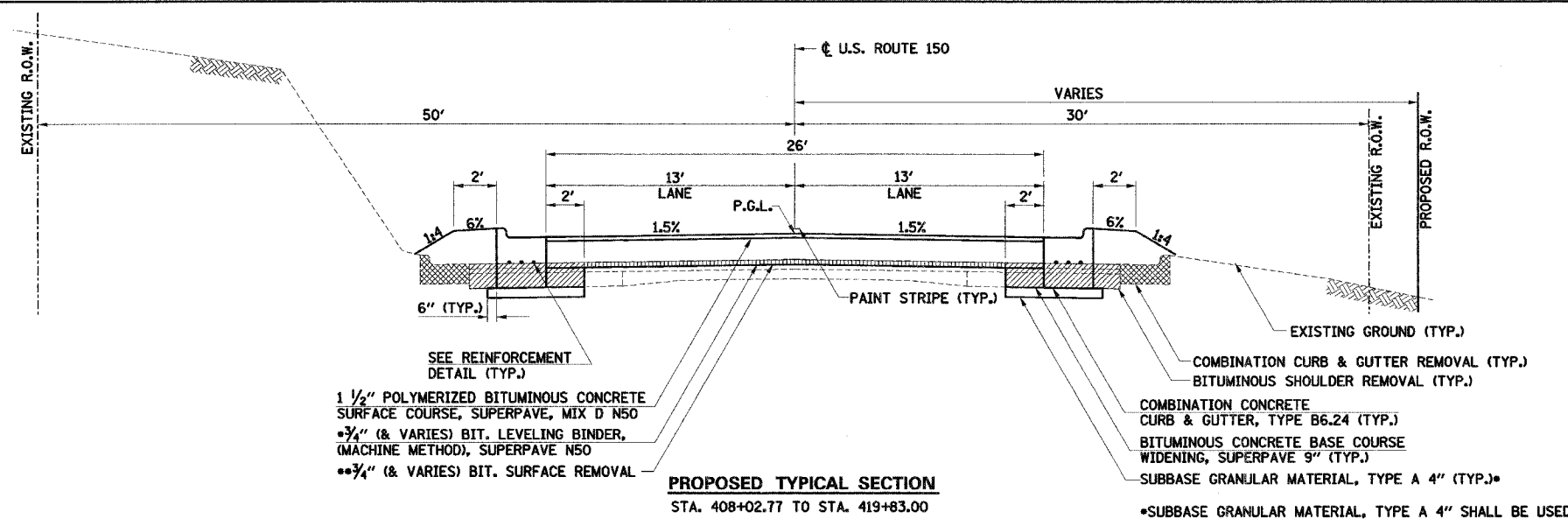

PROPOSED TYPICAL SECTION
 STA. 408+02.77 TO STA. 419+83.00

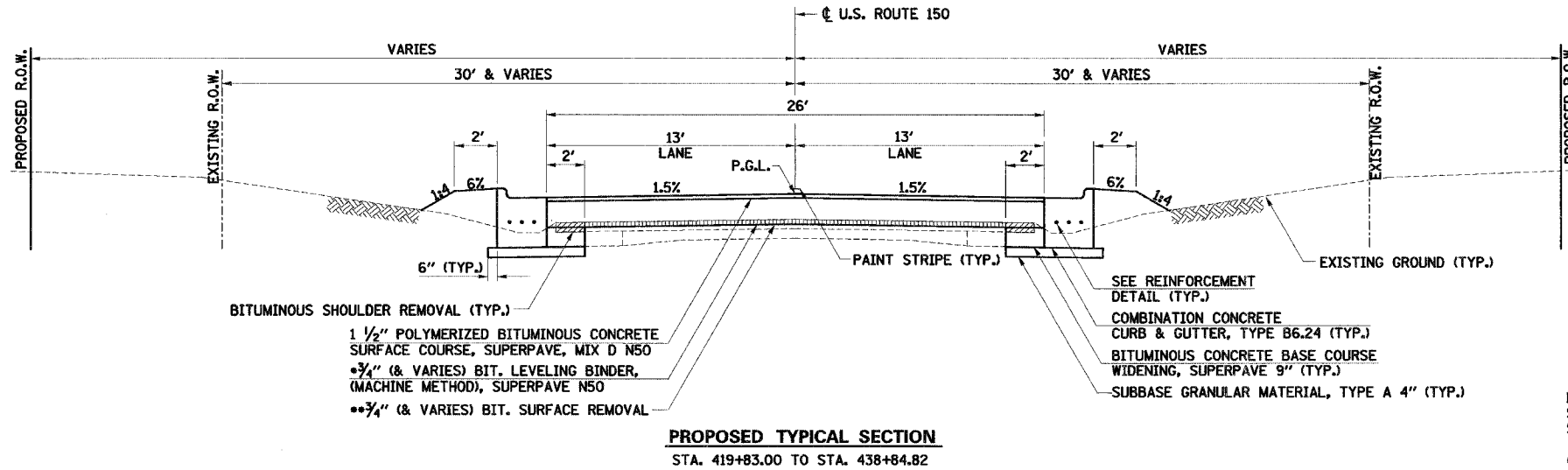

PROPOSED TYPICAL SECTION
 STA. 419+83.00 TO STA. 438+84.82

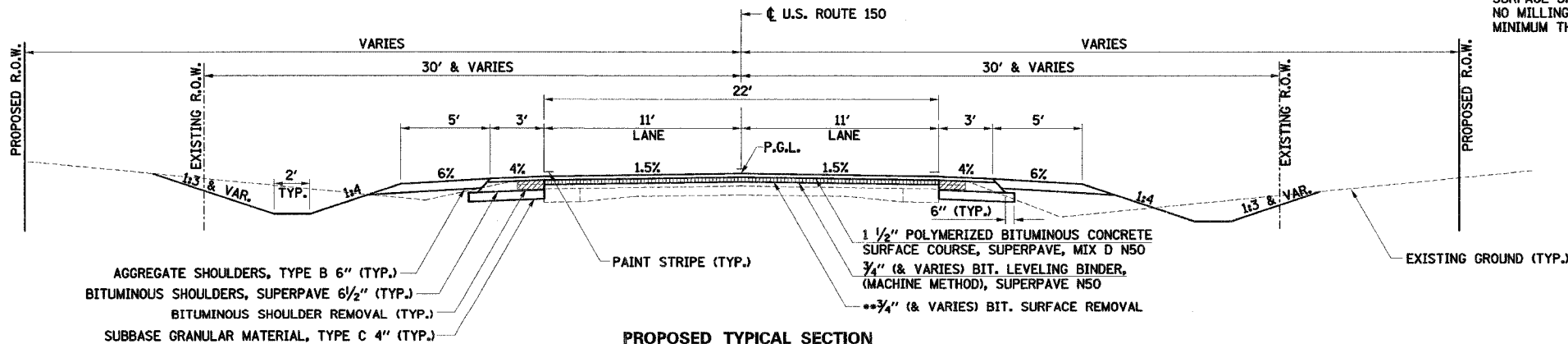

PROPOSED TYPICAL SECTION

- STA. 448+86.41 TO STA. 472+60.68
- STA. 482+51.13 TO STA. 490+25.44
- STA. 497+45.62 TO STA. 503+72.72
- STA. 512+35.04 TO STA. 524+61.64
- STA. 534+41.59 TO STA. 619+14.45
- STA. 629+47.77 TO STA. 639+42.70
- STA. 647+06.99 TO STA. 678+82.59
- STA. 688+72.06 TO STA. 706+80.30
- STA. 716+85.63 TO STA. 737+22.73
- STA. 745+05.09 TO STA. 755+00.00

ILLINOIS DEPARTMENT OF TRANSPORTATION
 F.A.S. 1517 (U.S. ROUTE 150)
PROPOSED TYPICAL SECTIONS

SCALE: VERT. _____
 HORIZ. _____
 DATE _____ DRAWN BY _____
 CHECKED BY _____

DATE _____ BY _____
 SURVEYED _____
 ALIGNED _____
 CHECKED _____
 PLOTTED _____
 FILE NO. _____

DATE _____ BY _____
 PROFILE SURVEYED _____
 GRADES CHECKED _____
 NOTE BOOK _____
 NO. _____
 STRUCTURE NOTATIONS CHECKED _____

COMPANY NAME: #COMPANY NAME#
 PROJECT CONTACT: #PROJECT CONTACT#
 CLIENT: #CLIENT#
 DATE: #DATE#
 TIME: #TIME#
 FILES: #FILES#

F.A.S. RTE.	SECTION	COUNTY	TOTAL SHEETS	SHEET NO.
1517 (2)RS-3 (3)RS-4		MCLEAN	223	8
STA. _____ TO STA. _____		ILLINOIS FED. AID PROJECT		

66383

DATE	BY	BY	DATE
PLAN	NO. _____	NO. _____	NO. _____

DATE	BY	BY	DATE
PROFILE	NO. _____	NO. _____	NO. _____

COMPANY NAME: # COMPANY NAME #
 PROJECT CONTACT: # PROJECT CONTACT #
 CLIENT: # CLIENT #
 DATES: # DATES #
 FILES: # FILES #

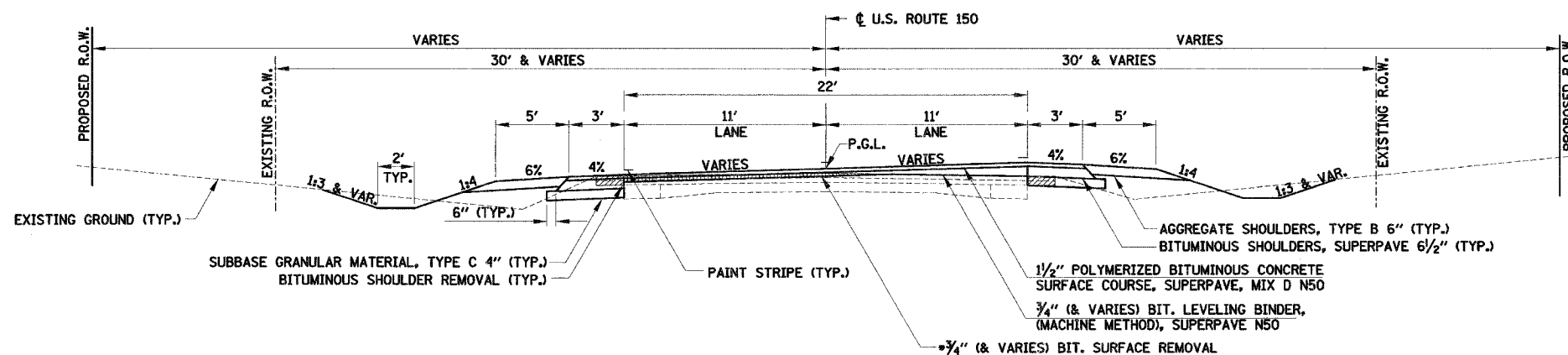

PROPOSED TYPICAL SECTION

STA. 438+84.82 TO STA. 448+86.41
 STA. 490+25.44 TO STA. 497+45.62
 STA. 524+61.64 TO STA. 534+41.59
 STA. 619+14.45 TO STA. 629+47.77
 STA. 678+82.59 TO STA. 688+72.06
 STA. 737+22.73 TO STA. 745+05.09

SUPERELEVATION TRANSITIONS:

STA. 437+43.00 TO STA. 438+84.82
 STA. 448+86.41 TO STA. 450+28.00
 STA. 489+11.00 TO STA. 490+25.44
 STA. 497+45.62 TO STA. 498+60.00
 STA. 523+12.00 TO STA. 524+61.64
 STA. 534+41.59 TO STA. 535+92.00
 STA. 618+22.00 TO STA. 619+14.45
 STA. 629+47.77 TO STA. 630+40.00
 STA. 677+65.00 TO STA. 678+82.59
 STA. 688+72.06 TO STA. 689+90.00
 STA. 735+69.00 TO STA. 737+22.73
 STA. 745+05.09 TO STA. 746+59.00

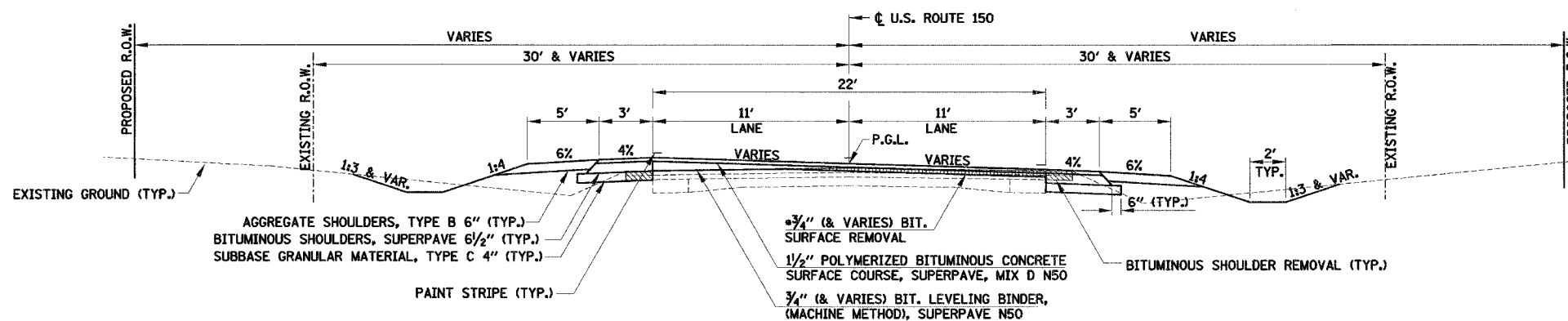

PROPOSED TYPICAL SECTION

STA. 472+60.68 TO STA. 482+51.13
 STA. 503+72.72 TO STA. 512+35.04
 STA. 639+42.70 TO STA. 647+06.99
 STA. 706+80.30 TO STA. 716+85.63

SUPERELEVATION TRANSITIONS:

STA. 471+25.00 TO STA. 472+60.68
 STA. 482+51.13 TO STA. 483+87.00
 STA. 502+26.00 TO STA. 503+72.72
 STA. 512+35.04 TO STA. 513+82.00
 STA. 638+51.00 TO STA. 639+42.70
 STA. 647+06.99 TO STA. 647+99.00
 STA. 705+37.00 TO STA. 706+80.30
 STA. 716+85.63 TO STA. 718+29.00

• BITUMINOUS SURFACE REMOVAL DEPTH SHALL BE 3/4" AT THE CENTERLINE. MILLED SURFACE SHALL MAINTAIN THE PROPOSED PAVEMENT CROSS-SLOPE. NO MILLING SHALL BE REQUIRED WHEN THE EXISTING CROSS-SLOPE ALLOWS FOR THE 3/4" MINIMUM THICKNESS OF LEVELING BINDER TO BE PLACED.

NOTE:
 SEE SUPERELEVATION TRANSITION DETAILS FOR SUPERELEVATION RATES AND EDGE BREAKPOINT LOCATIONS.

ILLINOIS DEPARTMENT OF TRANSPORTATION

F.A.S. 1517 (U.S. ROUTE 150)

PROPOSED TYPICAL SECTIONS

SCALE: VERT.
 HORIZ.
 DATE

DRAWN BY
 CHECKED BY

F.A.S. RTE.	SECTION	COUNTY	TOTAL SHEETS	SHEET NO.
1517 (2)RS-3 (3)RS-4		MCLEAN	223	9
STA.	TO STA.			
FED. ROAD DIST. NO.	ILLINOIS FED. AID PROJECT			

66383

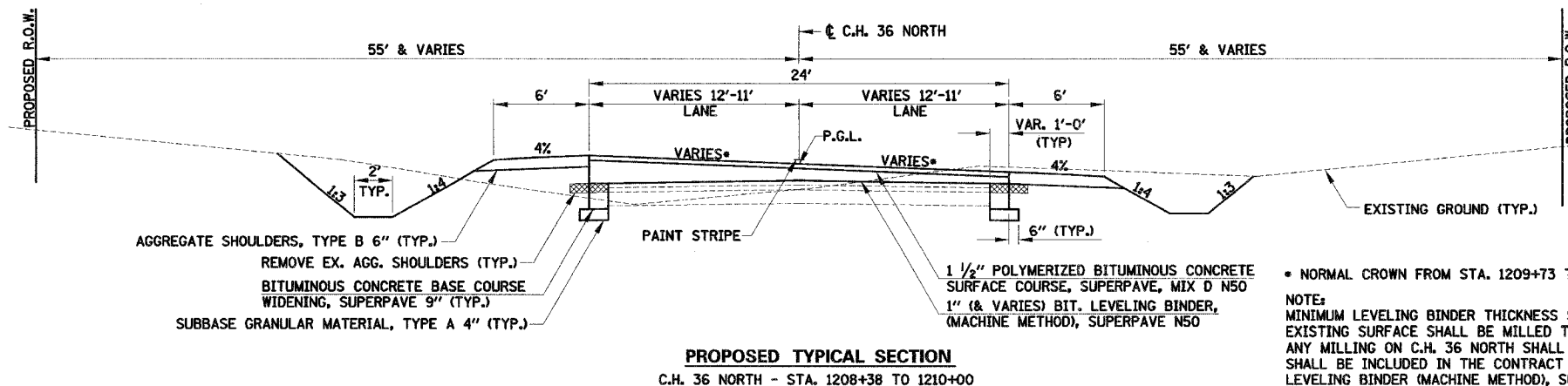
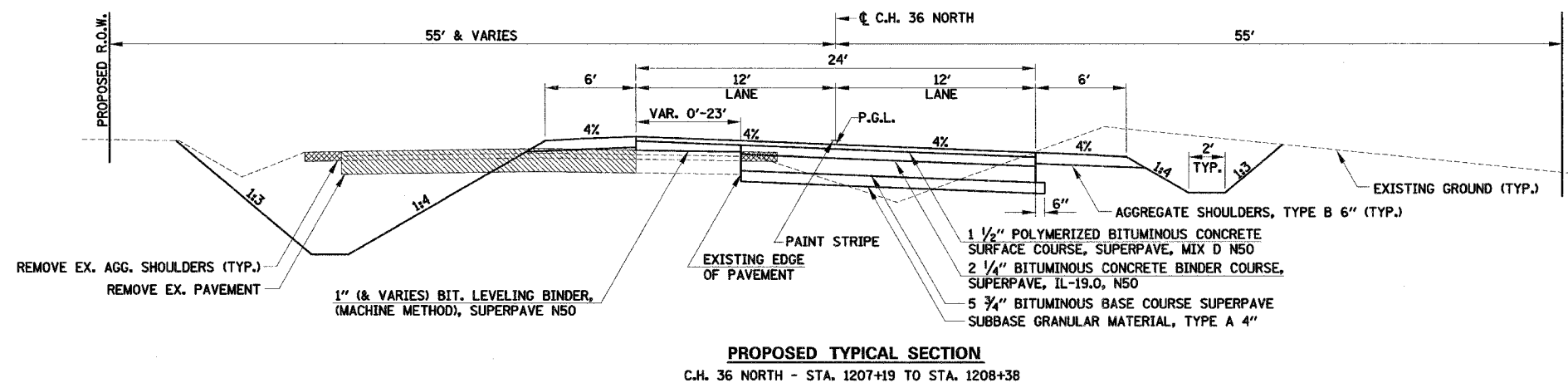
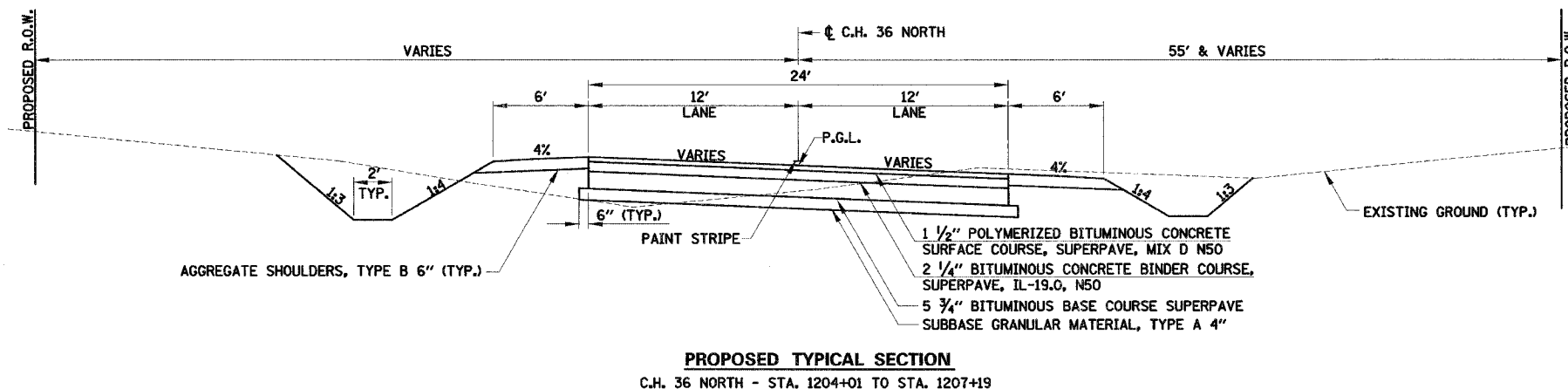
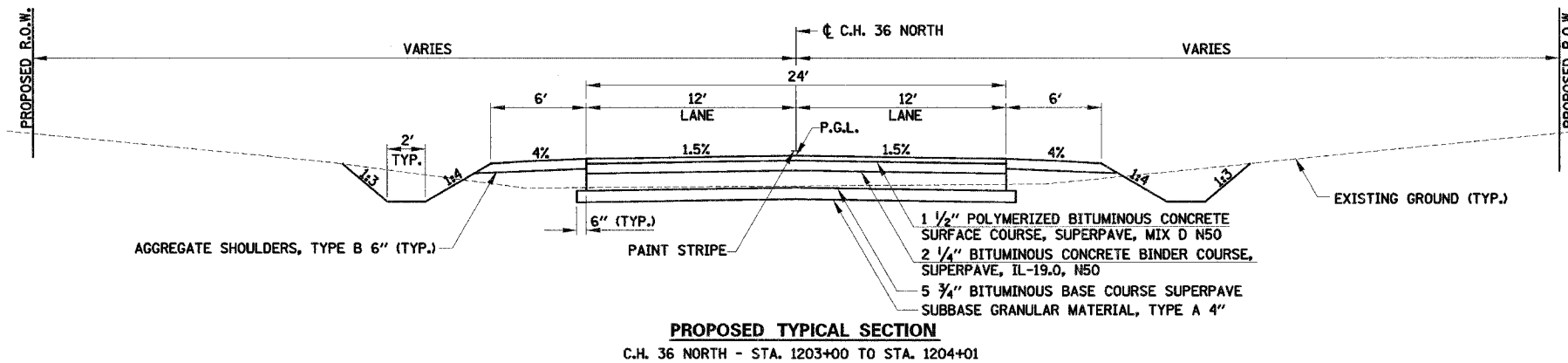

STRUCTURAL PAVEMENT DESIGN		
STRUCTURAL DESIGN TRAFFIC:	YEAR = 2016	
PV = 1745	SU = 187	MU = 18
ROAD/STREET CLASSIFICATION:	CLASS III	
PERCENT OF STRUCTURAL DESIGN TRAFFIC IN DESIGN LANE:		
P = 50%	S = 50%	M = 50%
TRAFFIC FACTOR:	ACTUAL TF = 0.28	AC GRADE = 20
	MINIMUM TF = N/A (COUNTY ROAD)	
PG GRADE:	BINDER = PG64-22	SURFACE = PG64-22
IBR:	5	

* NORMAL CROWN FROM STA. 1209+73 TO STA. 1210+00.

NOTE:
MINIMUM LEVELING BINDER THICKNESS SHALL BE 1". IF NECESSARY THE EXISTING SURFACE SHALL BE MILLED TO OBTAIN THE MINIMUM THICKNESS. ANY MILLING ON C.H. 36 NORTH SHALL NOT BE PAID FOR SEPARATELY, BUT SHALL BE INCLUDED IN THE CONTRACT UNIT PRICE PER TON FOR LEVELING BINDER (MACHINE METHOD), SUPERPAVE N50.

ILLINOIS DEPARTMENT OF TRANSPORTATION
F.A.S. 1517 (U.S. ROUTE 150)
PROPOSED TYPICAL SECTIONS

SCALE: VERT. _____
HORIZ. _____
DATE _____ DRAWN BY _____
CHECKED BY _____

PLAN	DATE
SURVEYED	BY
NOTE BOOK	NO.
ALIGNED	CHECKED
FILED	FILE NAME

PROFILE	DATE
SURVEYED	BY
NOTE BOOK	NO.
GRADES CHECKED	CHECKED
STATUS	STATUS

COMPANY NAME: #COMPANY NAME#
PROJECT CONTACT: #PROJECT CONTACT#
CLIENT: #CLIENT#
#DRAFTER# #STAMP#

F.A.S. RTE. 1517	SECTION 2)RS-3 (3)RS-4	COUNTY MCLEAN	TOTAL SHEETS 223	SHEET NO. 10
STA. _____		TO STA. _____		
FED. ROAD DIST. NO. _____ ILLINOIS FED. AID PROJECT				

66383

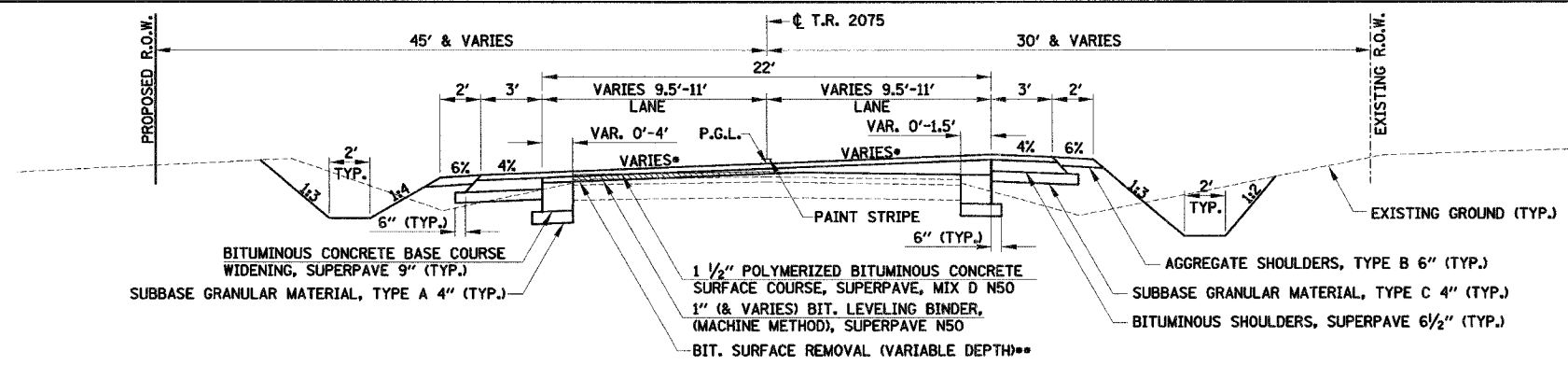

PROPOSED TYPICAL SECTION
T.R. 2075 - STA. 1300+20 TO STA. 1301+95

- * NORMAL CROWN FROM STA. 1300+20 TO STA. 1300+47.
- ** MINIMUM LEVELING BINDER THICKNESS SHALL BE 1".

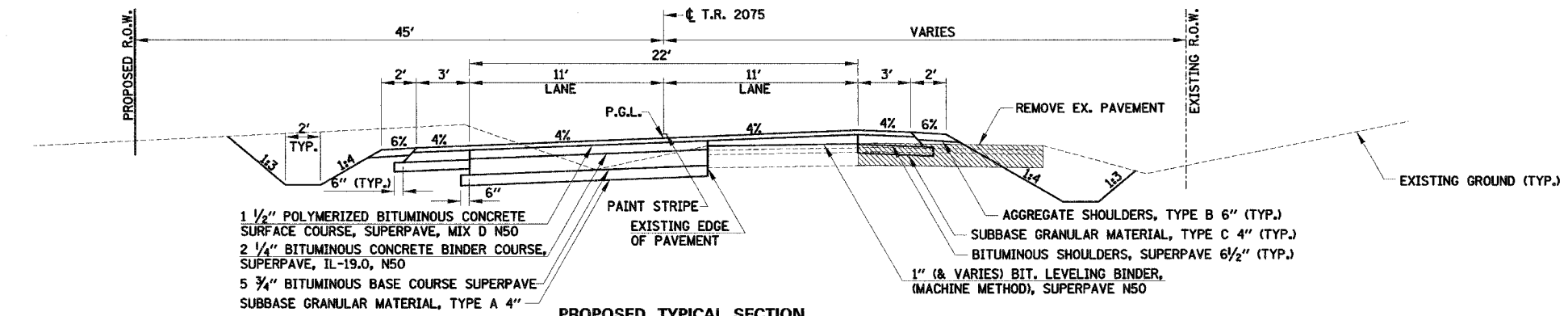

PROPOSED TYPICAL SECTION
T.R. 2075 - STA. 1301+95 TO STA. 1302+88

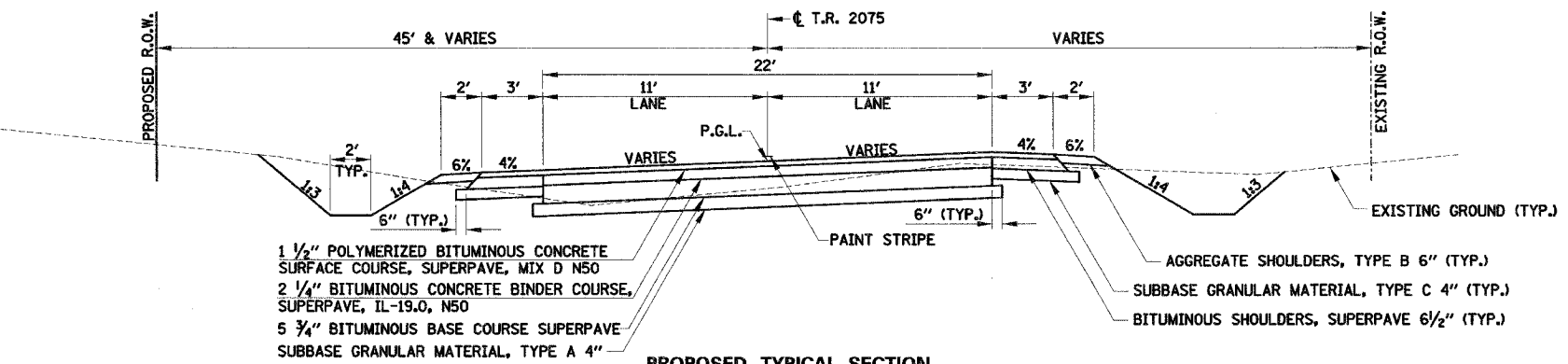

PROPOSED TYPICAL SECTION
T.R. 2075 - STA. 1302+88 TO STA. 1306+07

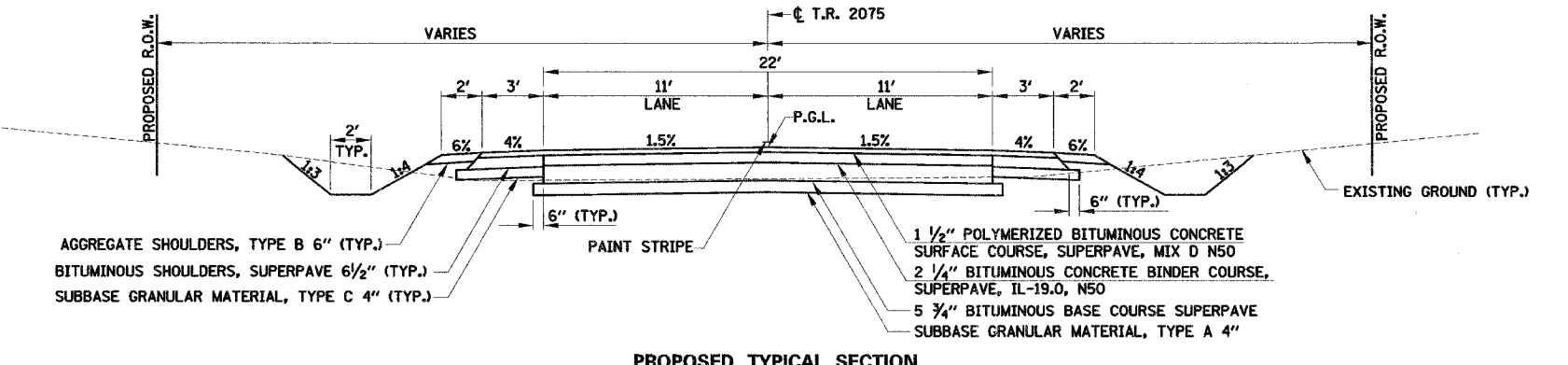

PROPOSED TYPICAL SECTION
T.R. 2075 - STA. 1306+07 TO STA. 1306+43.18

ILLINOIS DEPARTMENT OF TRANSPORTATION
F.A.S. 1517 (U.S. ROUTE 150)
PROPOSED TYPICAL SECTIONS

SCALE: VERT. _____
HORIZ. _____
DATE _____

DRAWN BY _____
CHECKED BY _____

PLAN	DATE
SURVEYED	BY
NOTE BOOK	NO.
ALIGNED	FILE NAME
CHECKED	
DATE	

PROFILE	DATE
SURVEYED	BY
NOTE BOOK	NO.
GRADES CHECKED	
PLANNED	
NOTATION	
DATE	

COMPANY NAME: #COMPANY NAME#
PROJECT CONTACT: #PROJECT CONTACT#
CLIENT: #CLIENT#
DATE: #DATE#
SCALE: #SCALE#

F.A.S. RTE.	SECTION	COUNTY	TOTAL SHEETS	SHEET NO.
1517 (2)RS-3 (3)RS-4		MCLEAN	223	11
STA. _____ TO STA. _____		FED. ROAD DIST. NO. - ILLINOIS FED. AID PROJECT		

66383

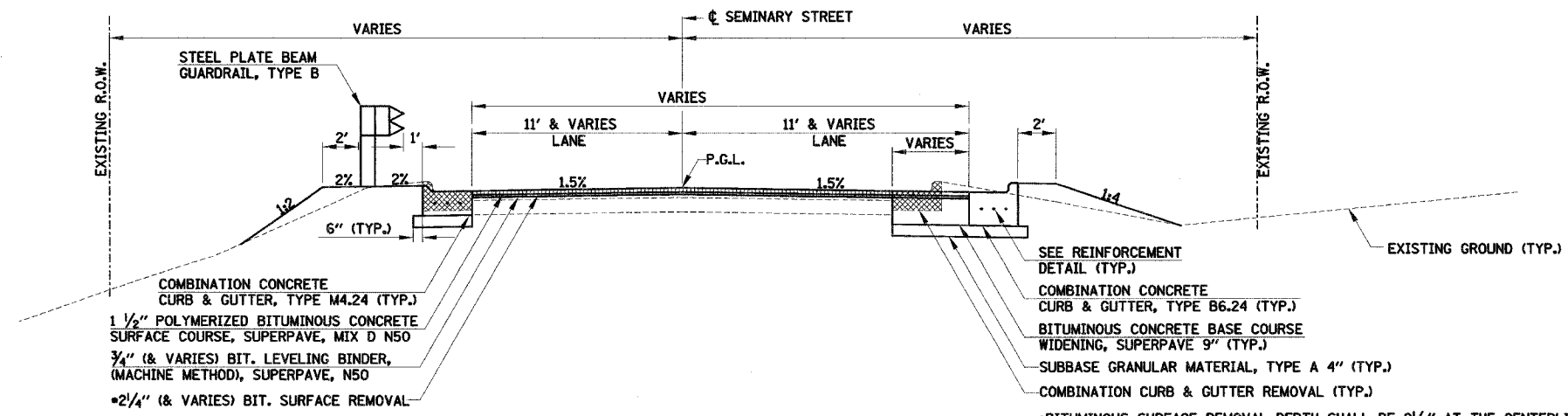

PROPOSED TYPICAL SECTION
SEMINARY STREET

SEE REINFORCEMENT DETAIL (TYP.)
COMBINATION CONCRETE CURB & GUTTER, TYPE B6.24 (TYP.)
BITUMINOUS CONCRETE BASE COURSE WIDENING, SUPERPAVE 9" (TYP.)
SUBBASE GRANULAR MATERIAL, TYPE A 4" (TYP.)
COMBINATION CURB & GUTTER REMOVAL (TYP.)
BITUMINOUS SURFACE REMOVAL DEPTH SHALL BE 2 1/4" AT THE CENTERLINE. MILLED SURFACE SHALL MAINTAIN A 1.5% CROSS-SLOPE. NO MILLING REQUIRED WHEN THE EXISTING CROSS-SLOPE ALLOWS FOR THE 3/4" MINIMUM THICKNESS OF LEVELING BINDER TO BE PLACED.

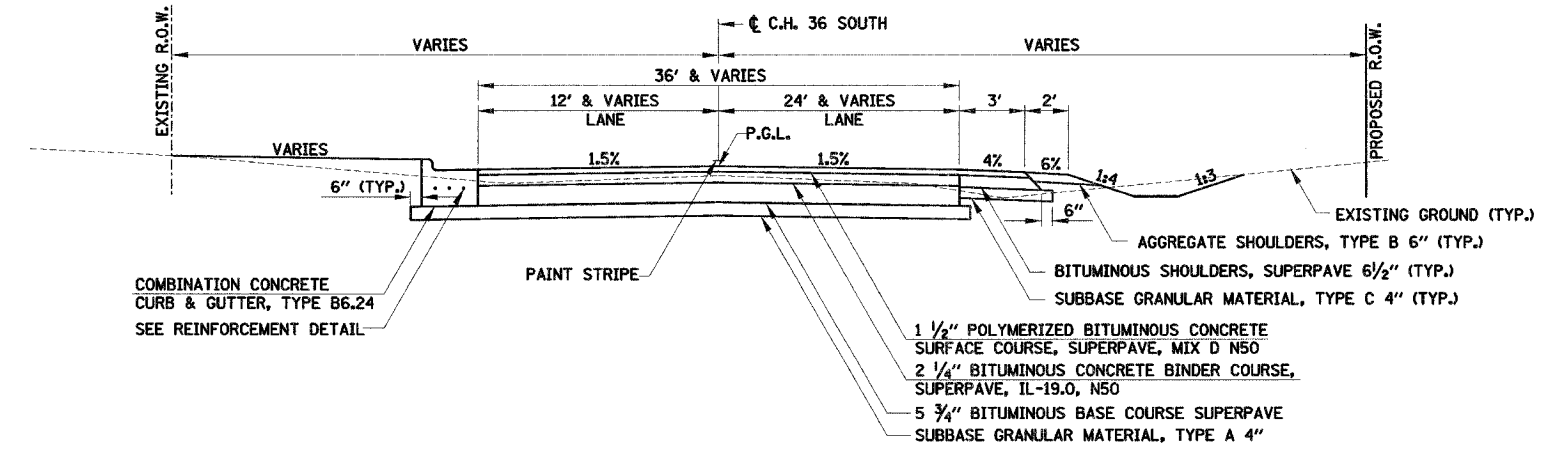

PROPOSED TYPICAL SECTION
C.H. 36 SOUTH

1 1/2" POLYMERIZED BITUMINOUS CONCRETE SURFACE COURSE, SUPERPAVE, MIX D N50
2 1/4" BITUMINOUS CONCRETE BINDER COURSE, SUPERPAVE, IL-19.0, N50
5 3/4" BITUMINOUS BASE COURSE SUPERPAVE
SUBBASE GRANULAR MATERIAL, TYPE A 4"

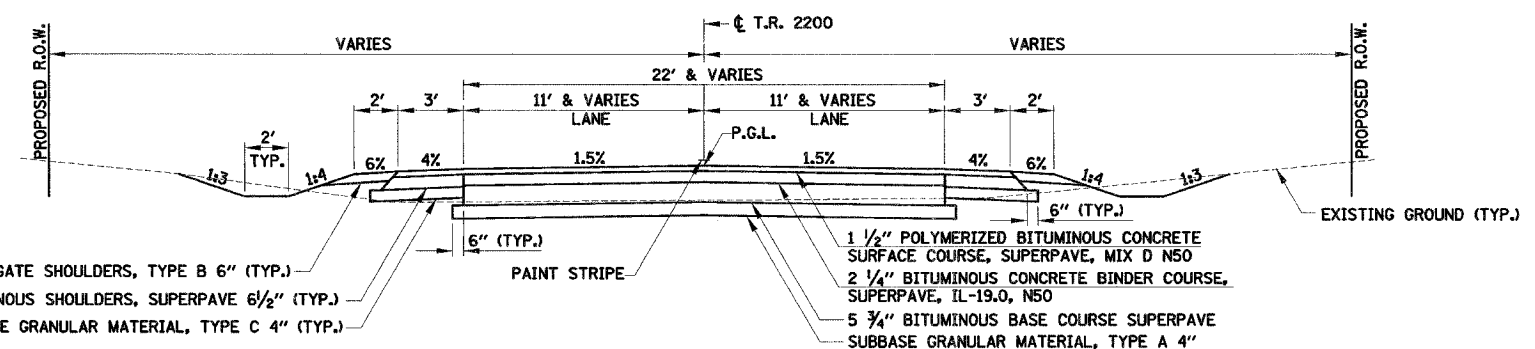

PROPOSED TYPICAL SECTION
T.R. 2200

AGGREGATE SHOULDERS, TYPE B 6" (TYP.)
BITUMINOUS SHOULDERS, SUPERPAVE 6 1/2" (TYP.)
SUBBASE GRANULAR MATERIAL, TYPE C 4" (TYP.)

1 1/2" POLYMERIZED BITUMINOUS CONCRETE SURFACE COURSE, SUPERPAVE, MIX D N50
2 1/4" BITUMINOUS CONCRETE BINDER COURSE, SUPERPAVE, IL-19.0, N50
5 3/4" BITUMINOUS BASE COURSE SUPERPAVE
SUBBASE GRANULAR MATERIAL, TYPE A 4"

ILLINOIS DEPARTMENT OF TRANSPORTATION
F.A.S. 1517 (U.S. ROUTE 150)
PROPOSED TYPICAL SECTIONS
SCALE: VERT. _____
HORIZ. _____
DATE _____ DRAWN BY _____
CHECKED BY _____

PLAN	DATE
BY	
CHECKED	
DATE	

PROFILE	DATE
BY	
CHECKED	
DATE	

COMPANY NAME: #COMPANY NAME#
PROJECT CONTACT: #PROJECT CONTACT#
CLIENT: #CLIENT#
DATE: #DATE#
SCALE: #SCALE#

F.A.S. SECTION	COUNTY	TOTAL SHEETS	SHEET NO.
1517 (2)RS-3 (3)RS-4	MCLEAN	223	12
STA. _____ TO STA. _____			
FED. ROAD DIST. NO. - ILLINOIS FED. AID PROJECT			

66383

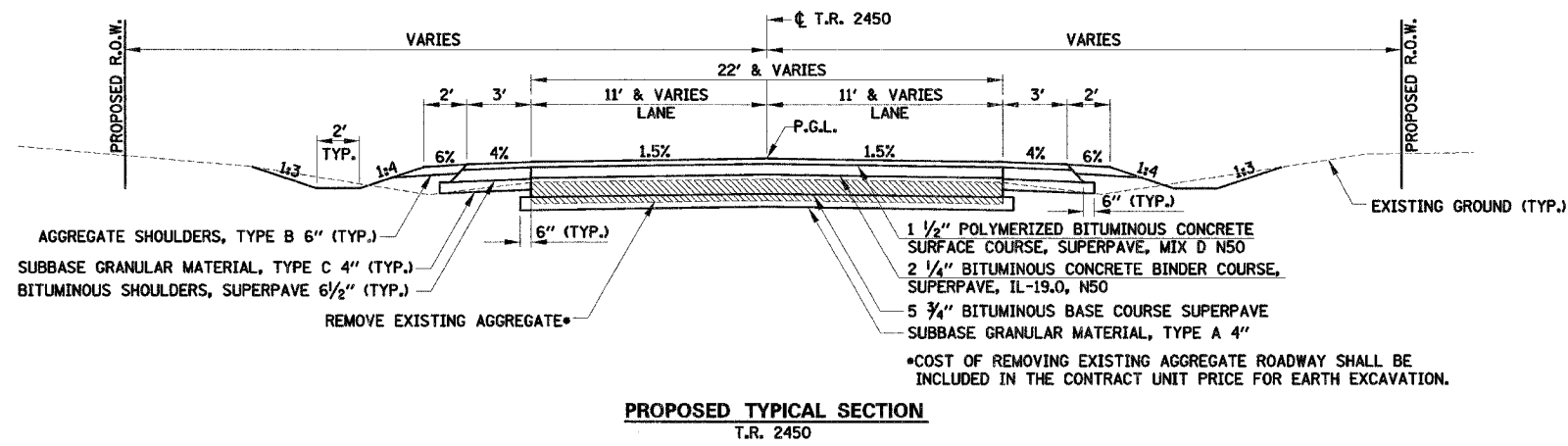
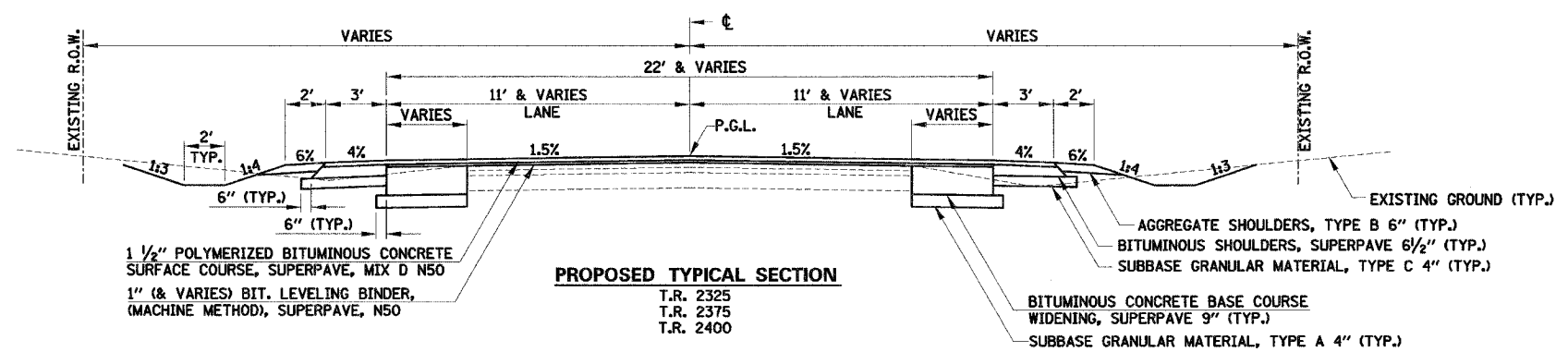

DATE _____ BY _____
SURVEYED _____
CHECKED _____
PLAN NO. _____

DATE _____ BY _____
SURVEYED _____
CHECKED _____
PROFILE NO. _____

COMPANY NAME: #COMPANY/NAME#
PROJECT CONTACT: #PROJECT_CONTACT#
CLIENT: #CLIENT#
DATE: #DATE#
TIME: #TIME#
FILES: #FILES#

ILLINOIS DEPARTMENT OF TRANSPORTATION
F.A.S. 1517 (U.S. ROUTE 150)
PROPOSED TYPICAL SECTIONS

SCALE: VERT. _____
HORIZ. _____
DATE _____

DRAWN BY _____
CHECKED BY _____

U.S. ROUTE 150 (STA. 437+90 TO STA. 449+81)

e = DESIGN SUPERELEVATION RATE = 3.5%

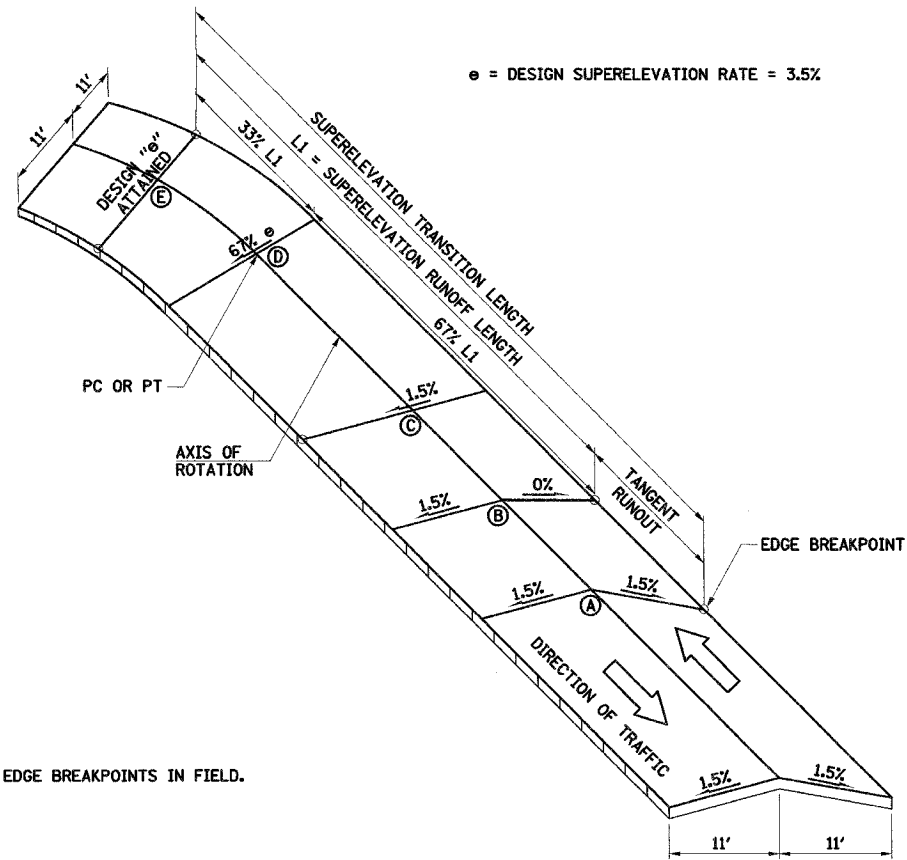

NOTE: ROUND ALL EDGE BREAKPOINTS IN FIELD.

U.S. ROUTE 150 (STA. 471+70 TO STA. 483+42)

e = DESIGN SUPERELEVATION RATE = 3.3%

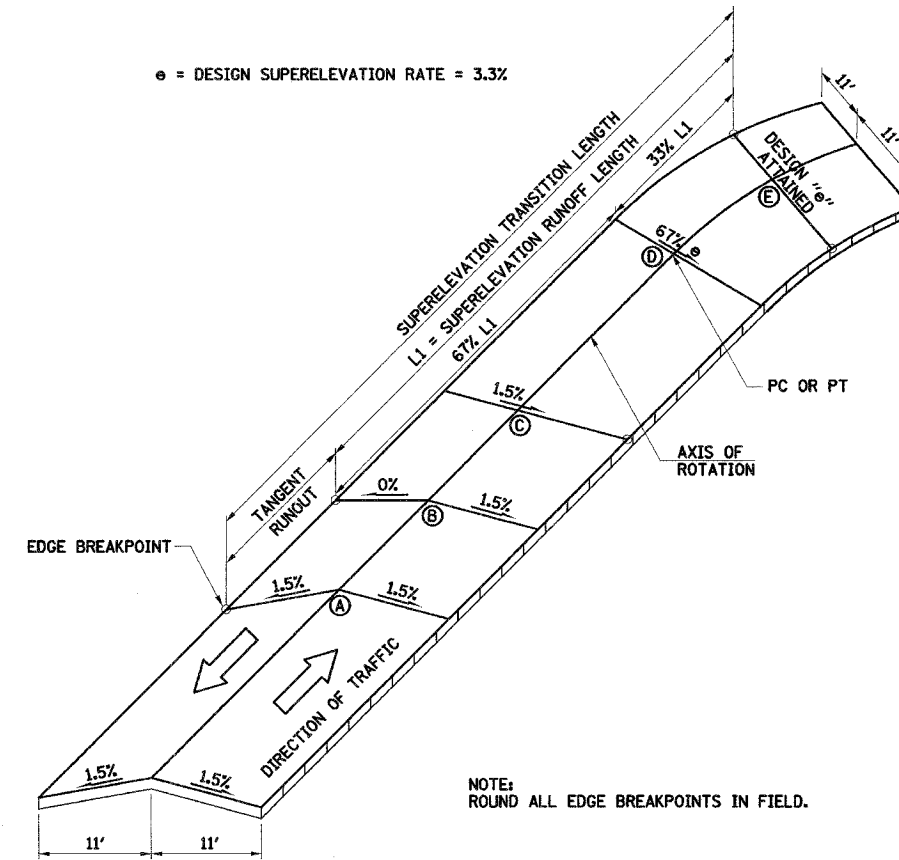

NOTE: ROUND ALL EDGE BREAKPOINTS IN FIELD.

F.A.S. R.T.E.	SECTION	COUNTY	TOTAL SHEETS	SHEET NO.
1517	2)RS-3 (3)RS-4	MCLEAN	223	13
STA. _____ TO STA. _____		ILLINOIS FED. AID PROJECT		

66383

DATE	
BY	
PLAN	
NO.	
NO.	
NO.	
NO.	
NO.	
NO.	
NO.	
NO.	

DATE	
BY	
PROFILE	
NO.	
NO.	
NO.	
NO.	
NO.	
NO.	
NO.	
NO.	

COMPANY NAME: #COMPANY/NAME#
 PROJECT CONTACT: #PROJECT/CONTACT#
 CLIENT: #CLIENT#
 DATE: #DATE#
 TIME: #TIME#

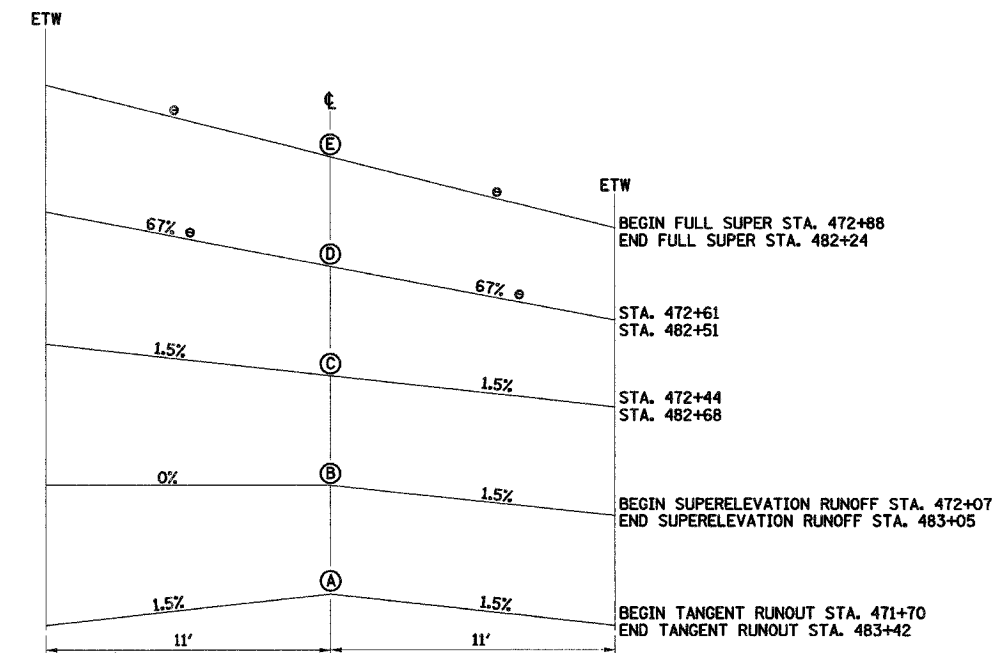
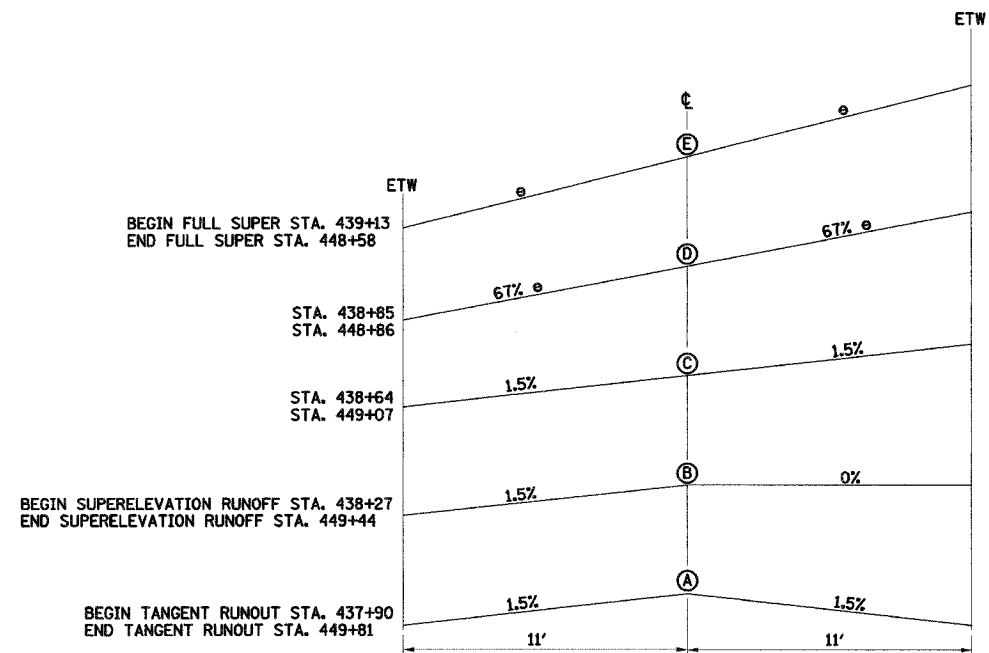

ILLINOIS DEPARTMENT OF TRANSPORTATION
 F.A.S. 1517 (U.S. ROUTE 150)
SUPERELEVATION TRANSITION DETAILS

SCALE: VERT. _____
 HORIZ. _____
 DATE _____

DRAWN BY _____
 CHECKED BY _____

U.S. ROUTE 150 (STA. 489+48 TO STA. 498+23)

• = DESIGN SUPERELEVATION RATE = 2.4%

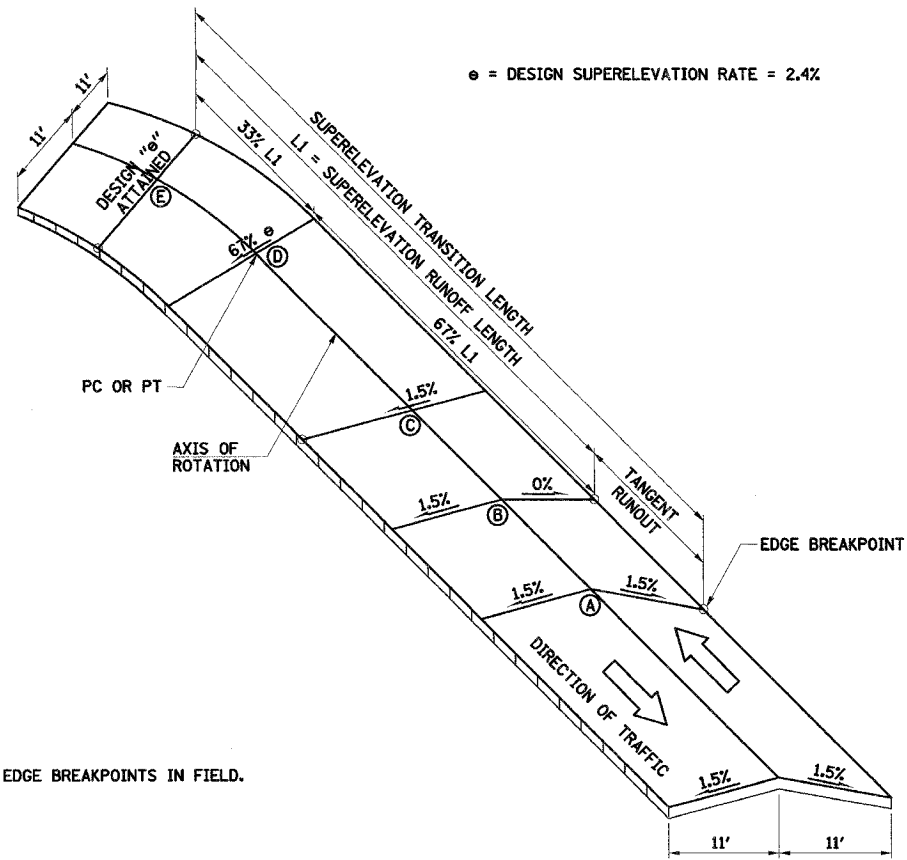

NOTE: ROUND ALL EDGE BREAKPOINTS IN FIELD.

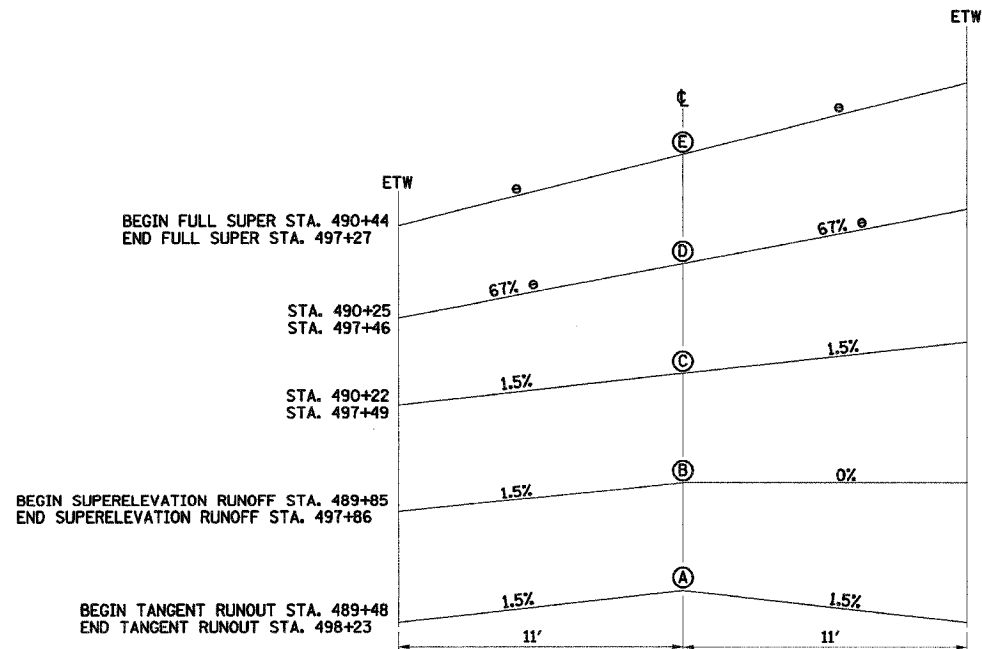

U.S. ROUTE 150 (STA. 502+75 TO STA. 513+33)

• = DESIGN SUPERELEVATION RATE = 3.7%

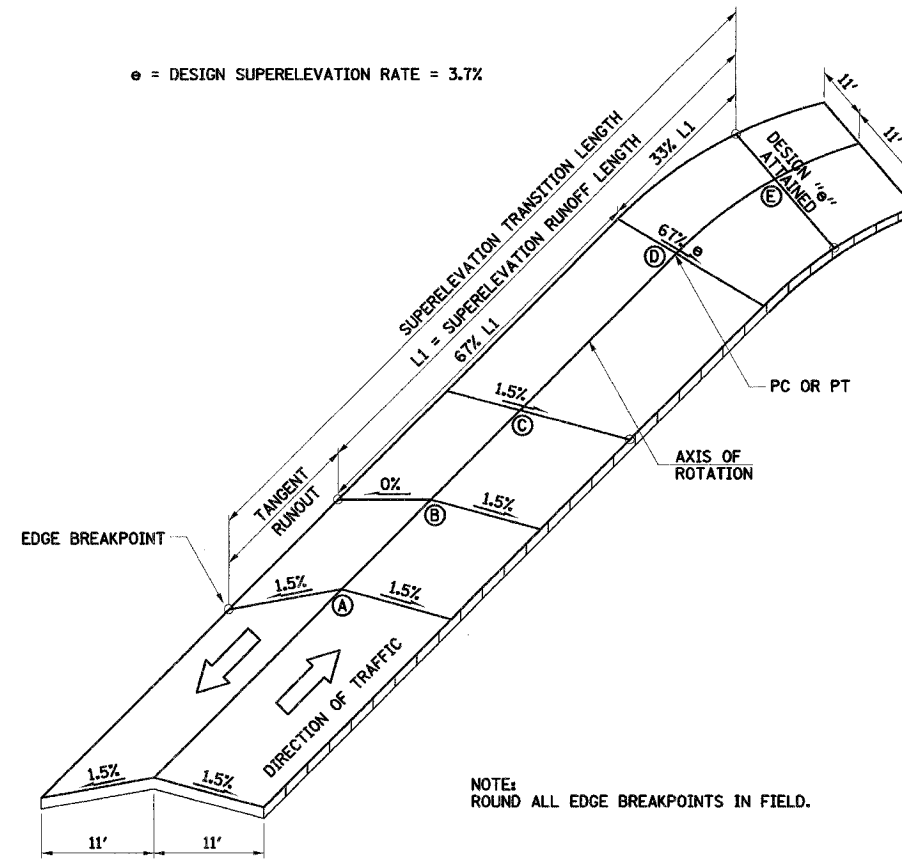

NOTE: ROUND ALL EDGE BREAKPOINTS IN FIELD.

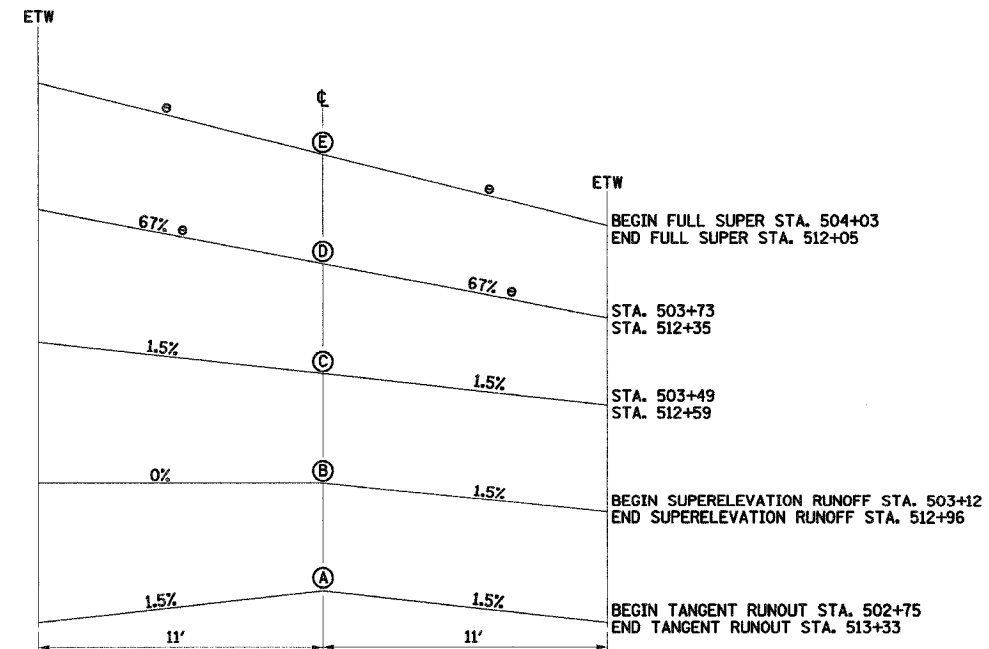

F.A.S. RTE.	SECTION	COUNTY	TOTAL SHEETS	SHEET NO.
1517	2)RS-3 (3)RS-4	MCLEAN	223	14
STA. _____ TO STA. _____		FED. ROAD DIST. NO. - ILLINOIS FED. AID PROJECT		

66383

ILLINOIS DEPARTMENT OF TRANSPORTATION
F.A.S. 1517 (U.S. ROUTE 150)
SUPERELEVATION TRANSITION DETAILS

SCALE: VERT. _____
HORIZ. _____
DATE _____ DRAWN BY _____
CHECKED BY _____

PLAN	NO.
NOTE BOOK	
SURVEYED	DATE
ALIGNED	BY
CHECKED	
FILED	
FILE NAME	

PROFILE	NO.
NOTE BOOK	
SURVEYED	DATE
GRADES CHECKED	BY
NOTED	
MEASURE	
STATISTICS	
OK'D	

COMPANY NAME: #COMPANY NAME#
PROJECT CONTACT: #PROJECT CONTACT#
CLIENT: #CLIENT#
DATE: #DATE#
SCALE: #SCALE#

U.S. ROUTE 150 (STA. 523+63 TO STA. 535+41)

• = DESIGN SUPERELEVATION RATE = 3.8%

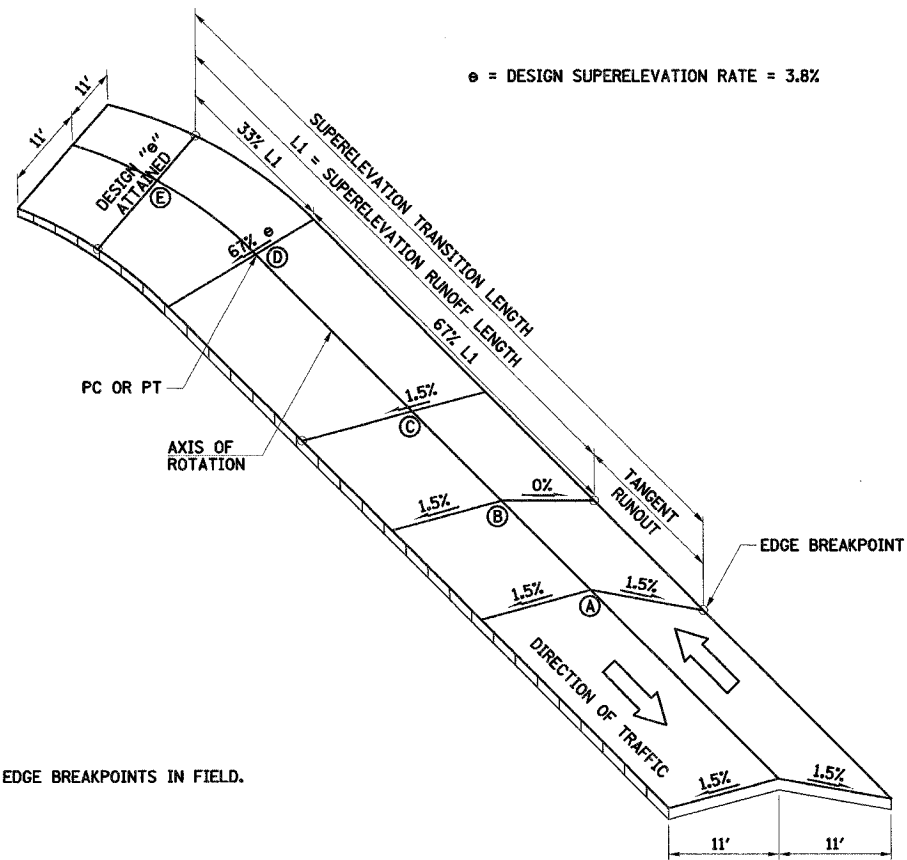

NOTE:
ROUND ALL EDGE BREAKPOINTS IN FIELD.

U.S. ROUTE 150 (STA. 618+52 TO STA. 630+10)

• = DESIGN SUPERELEVATION RATE = 1.5%

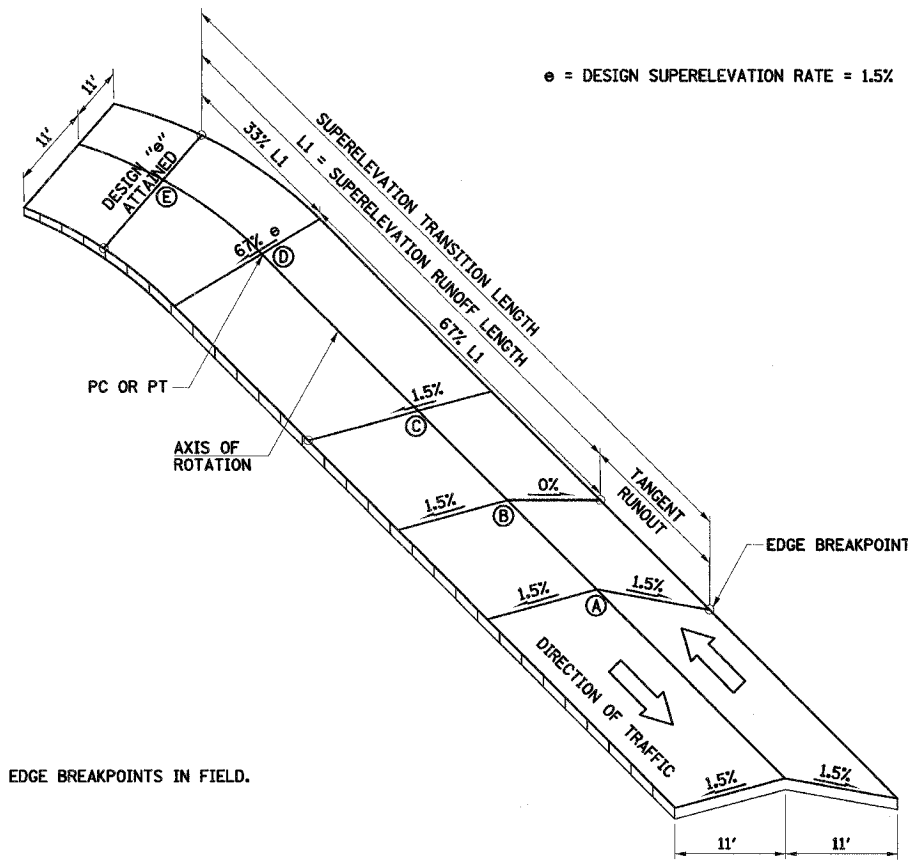

NOTE:
ROUND ALL EDGE BREAKPOINTS IN FIELD.

F.A.S. RTE.	SECTION	COUNTY	TOTAL SHEETS	SHEET NO.
1517	(2)RS-3 (3)RS-4	MCLEAN	223	15
STA.	TO STA.			
FED. ROAD DIST. NO. ILLINOIS FED. AID PROJECT				

66383

PLAN	NO.	DATE
BY		
DATE		
NO.		
DATE		
NO.		
DATE		
NO.		
DATE		
NO.		

PROFILE	NO.	DATE
BY		
DATE		
NO.		
DATE		
NO.		
DATE		
NO.		
DATE		
NO.		

COMPANY NAME: #COMPANY-NAME#
PROJECT CONTACT: #PROJECT-CONTACT#
CLIENT: #CLIENT#
#DATES# #TIME#
#FILES#

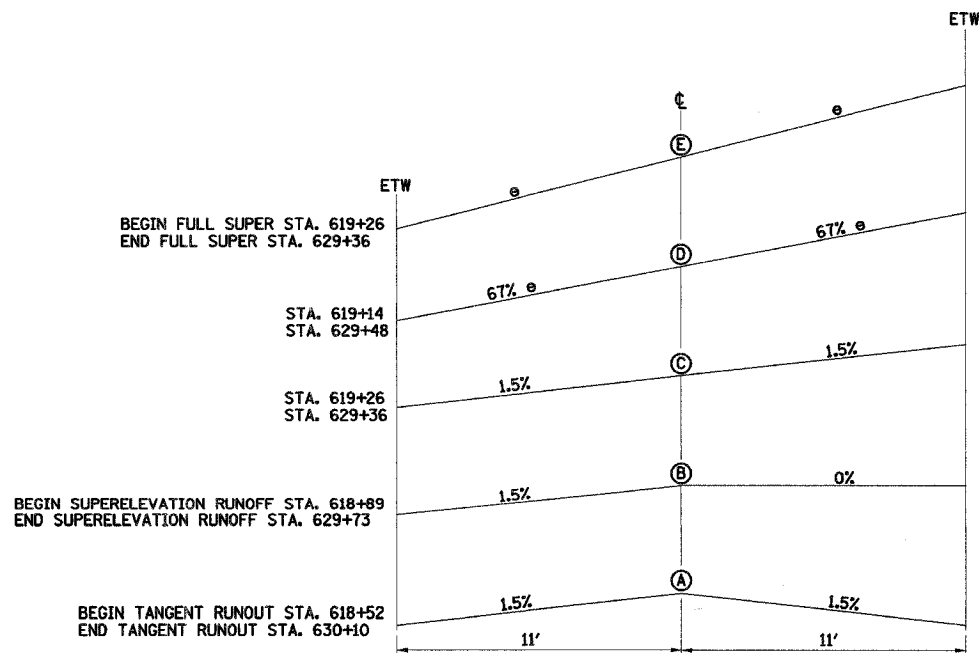
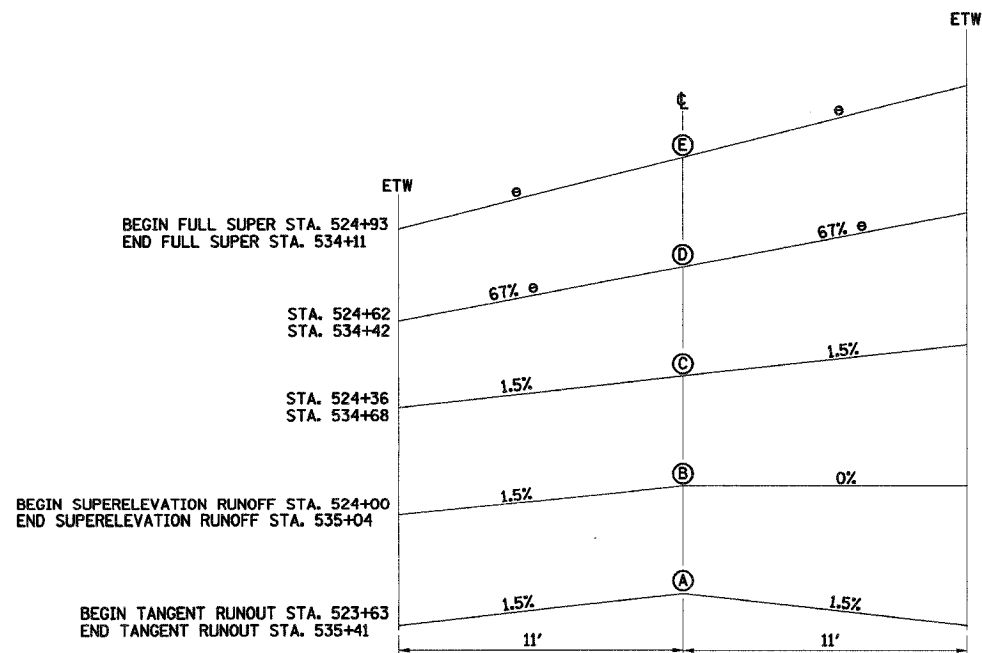

NOTE:
WITH A DESIGN SUPERELEVATION RATE OF 1.5%,
LOCATIONS "C" AND "E" ARE THE SAME AND
LOCATION "D" ONLY APPLIES TO THE HIGH SIDE.

ILLINOIS DEPARTMENT OF TRANSPORTATION
F.A.S. 1517 (U.S. ROUTE 150)
SUPERELEVATION TRANSITION DETAILS

SCALE: VERT.
DATE

DRAWN BY
CHECKED BY

U.S. ROUTE 150 (STA. 638+81 TO STA. 647+69)

e = DESIGN SUPERELEVATION RATE = 1.5%

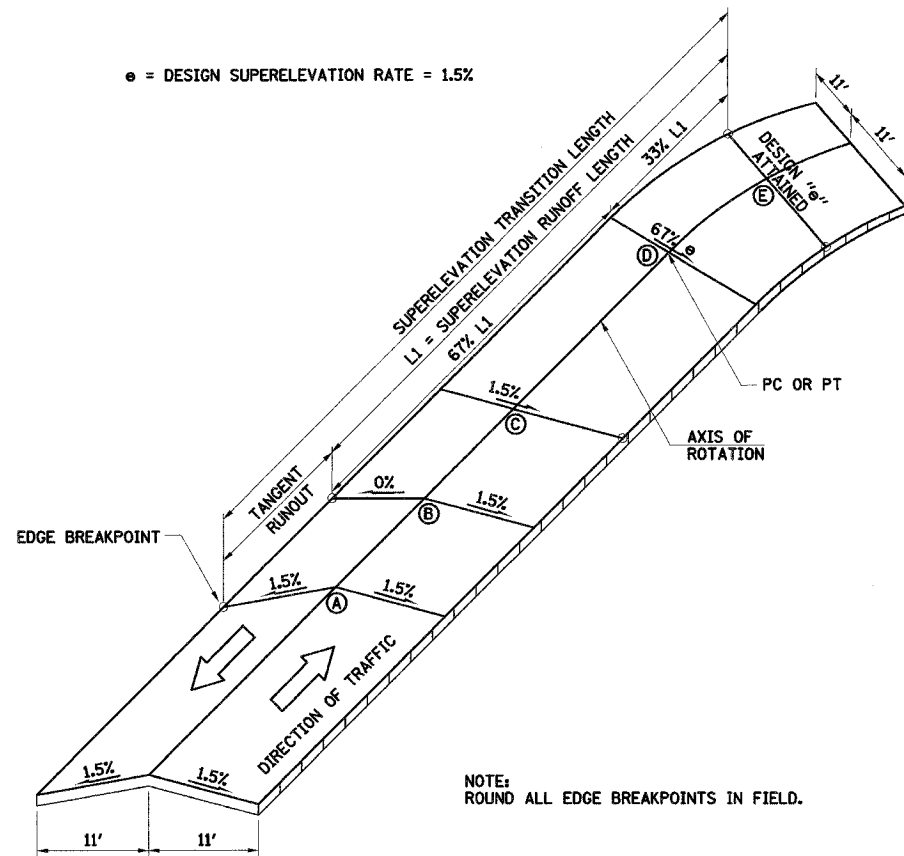

NOTE: ROUND ALL EDGE BREAKPOINTS IN FIELD.

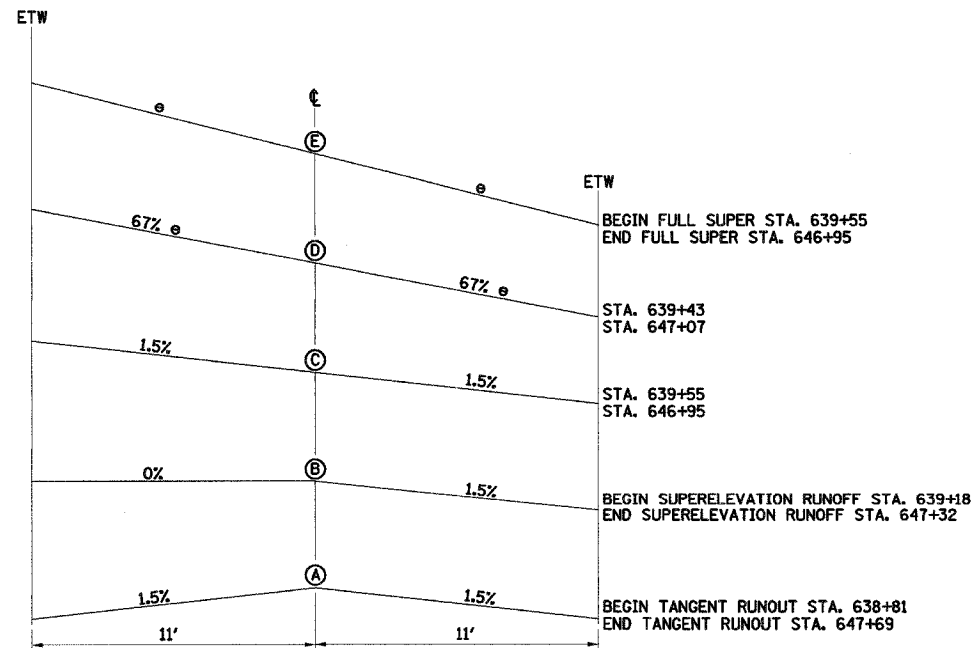

NOTE: WITH A DESIGN SUPERELEVATION RATE OF 1.5%, LOCATIONS "C" AND "E" ARE THE SAME AND LOCATION "D" ONLY APPLIES TO THE HIGH SIDE.

U.S. ROUTE 150 (STA. 678+04 TO STA. 689+51)

e = DESIGN SUPERELEVATION RATE = 2.5%

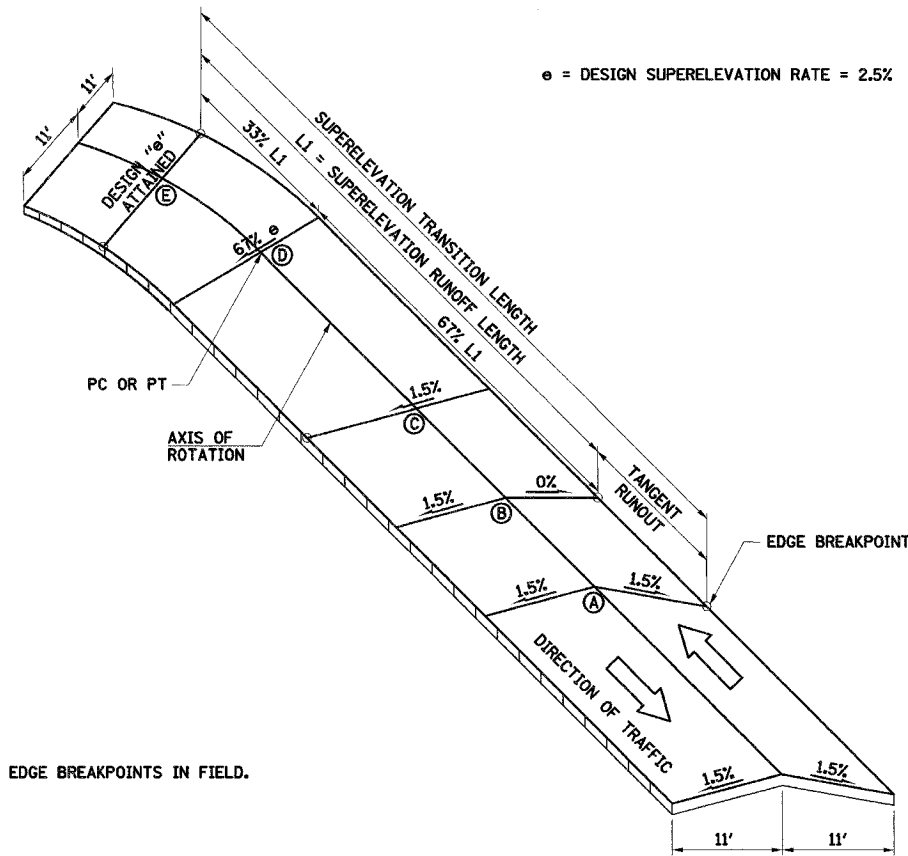

NOTE: ROUND ALL EDGE BREAKPOINTS IN FIELD.

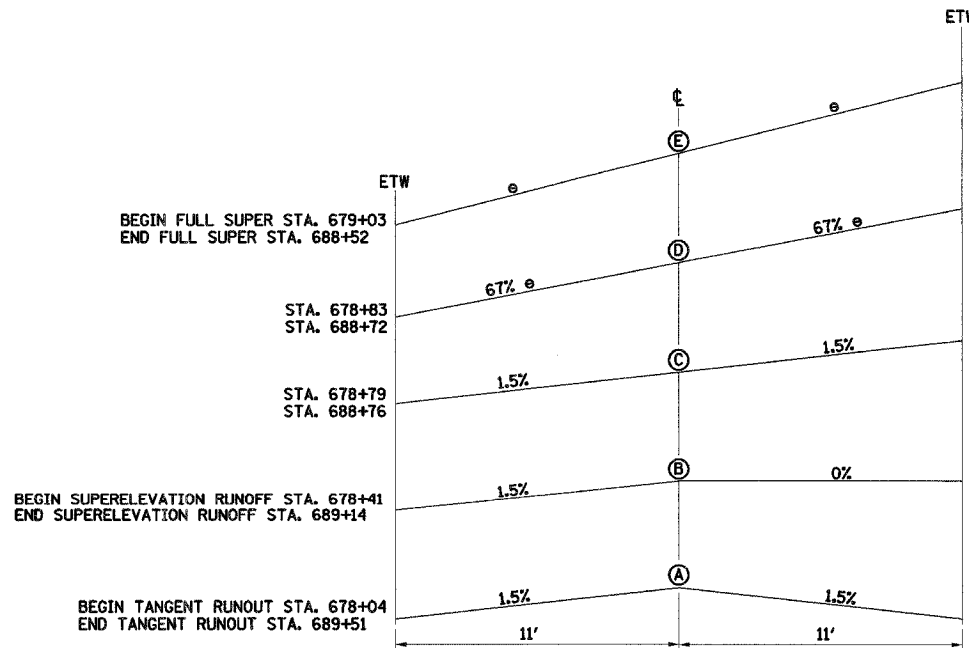

F.A.S. RTE.	SECTION	COUNTY	TOTAL SHEETS	SHEET NO.
1517	(2)RS-3 (3)RS-4	MCLEAN	223	16
STA. _____ TO STA. _____		FED. ROAD DIST. NO. ILLINOIS FED. AID PROJECT		

66383

ILLINOIS DEPARTMENT OF TRANSPORTATION
F.A.S. 1517 (U.S. ROUTE 150)
SUPERELEVATION TRANSITION DETAILS

SCALE: VERT. _____
HORIZ. _____
DATE _____

DRAWN BY _____
CHECKED BY _____

PLAN	DATE
SURVEYED	BY _____
PLOTTED	BY _____
CHECKED	BY _____
NO. OF WAYS CHECKED	_____
CADD FILE NAME	_____

PROFILE	DATE
SURVEYED	BY _____
PLOTTED	BY _____
CHECKED	BY _____
BLANK NOTED	_____
STRUCTURE NOTATIONS CHNG	_____

COMPANY NAME: _____
PROJECT CONTACT: _____
CLIENT: _____
DATE: _____
FILE# _____

F.A.S. RTE.	SECTION	COUNTY	TOTAL SHEETS	SHEET NO.
1517	12)RS-3 (3)RS-4	MCLEAN	223	17
STA. _____		TO STA. _____		
FED. ROAD DIST. NO. _____		ILLINOIS FED. AID PROJECT		

66383

U.S. ROUTE 150 (STA. 705+84 TO STA. 717+82)

e = DESIGN SUPERELEVATION RATE = 3.6%

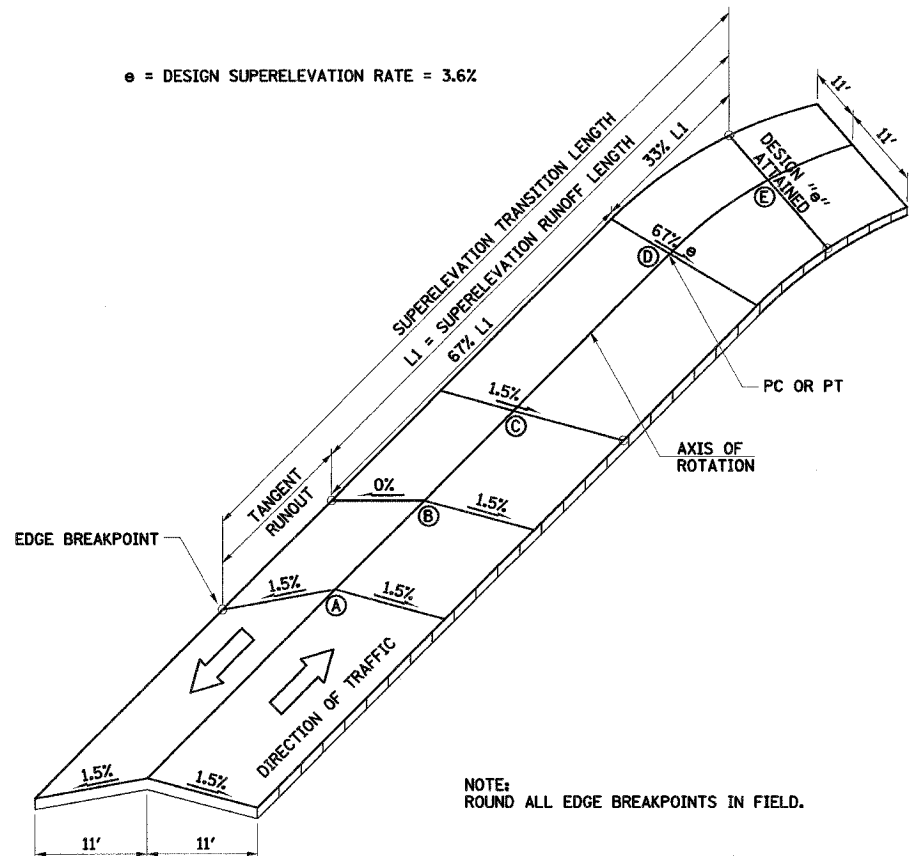

NOTE: ROUND ALL EDGE BREAKPOINTS IN FIELD.

U.S. ROUTE 150 (STA. 736+20 TO STA. 746+08)

e = DESIGN SUPERELEVATION RATE = 4.0%

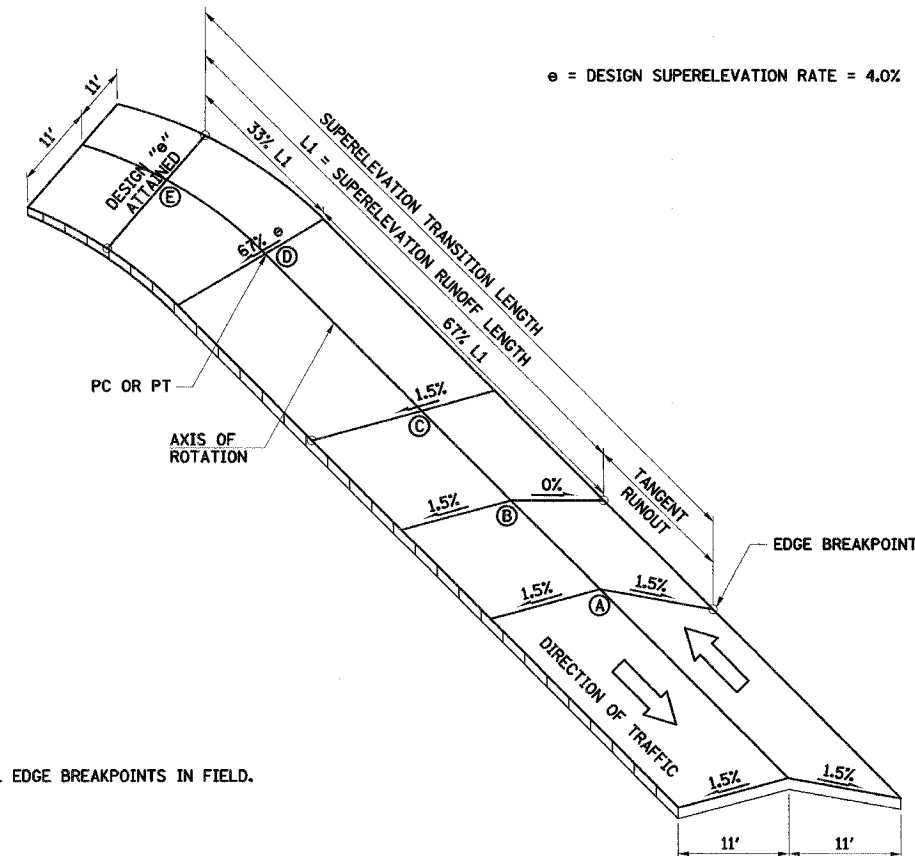

NOTE: ROUND ALL EDGE BREAKPOINTS IN FIELD.

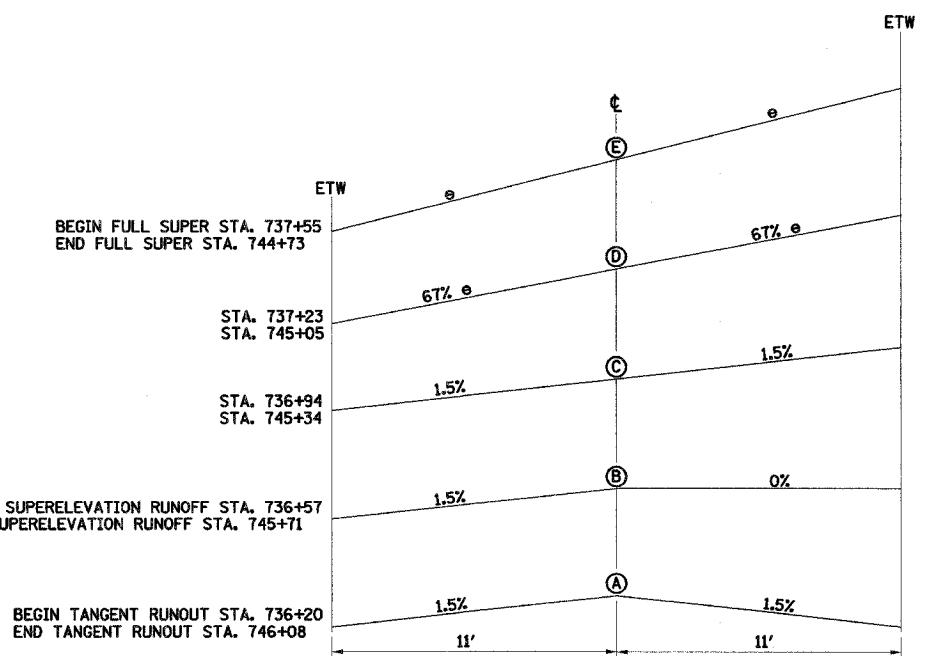
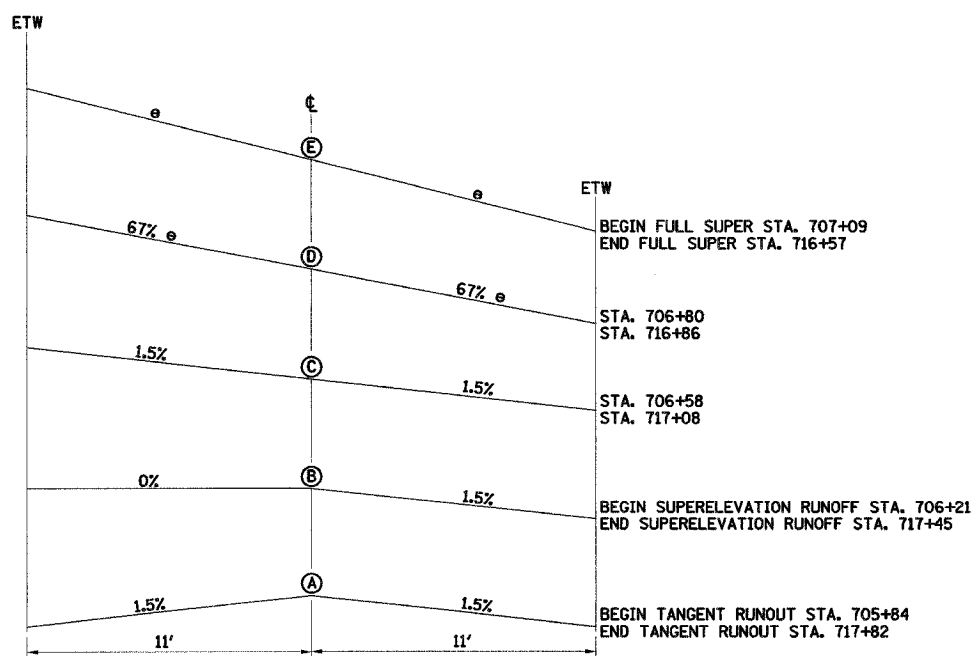

ILLINOIS DEPARTMENT OF TRANSPORTATION
F.A.S. 1517 (U.S. ROUTE 150)
SUPERELEVATION TRANSITION DETAILS

SCALE: VERT. _____
HORIZ. _____
DATE _____ DRAWN BY _____
CHECKED BY _____

PLAN	DATE
SURVEYED	BY
NOTE BOOK	NO.
ALIGNED	CHECKED
BY	DATE
CAD FILE NAME	

PROFILE	DATE
SURVEYED	BY
NOTE BOOK	NO.
GRADES CHECKED	
BY	DATE
STRUCTURE NOTATIONS CHECKED	

COMPANY NAME: #COMPANY/NAME#
PROJECT CONTACT: #PROJECT_CONTACT#
CLIENT: #CLIENT/F#
#DATES# #FILES#

C.H. 36 (STA. 1204+01 TO STA. 1209+73)

e = DESIGN SUPERELEVATION RATE = 4.0%

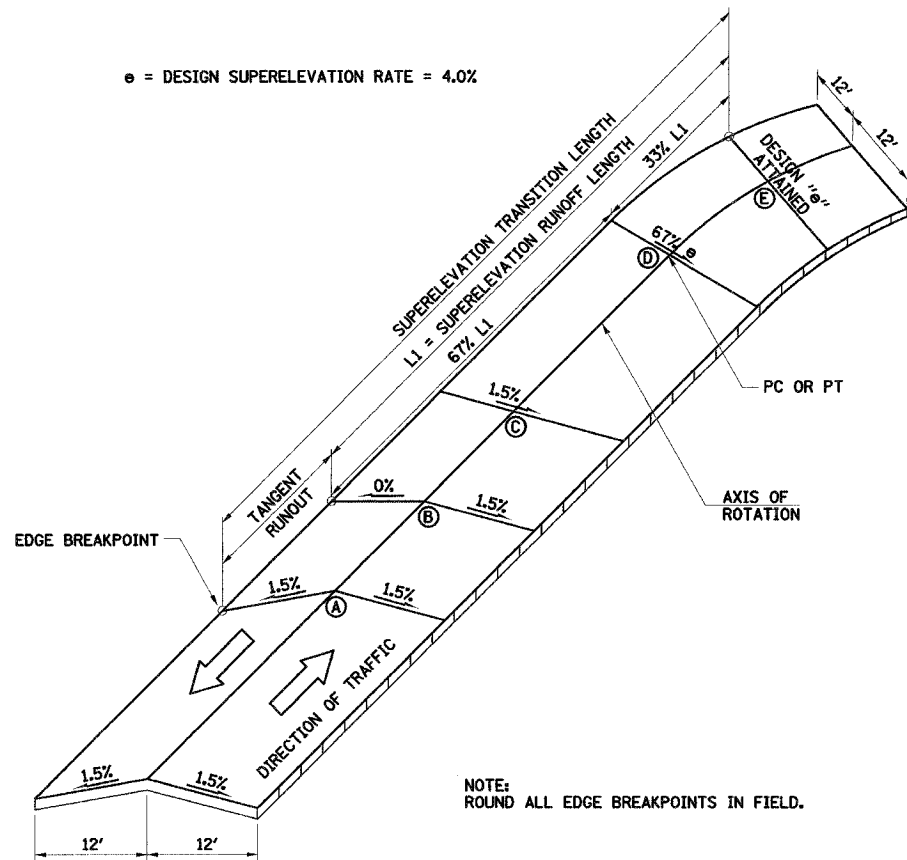

NOTE: ROUND ALL EDGE BREAKPOINTS IN FIELD.

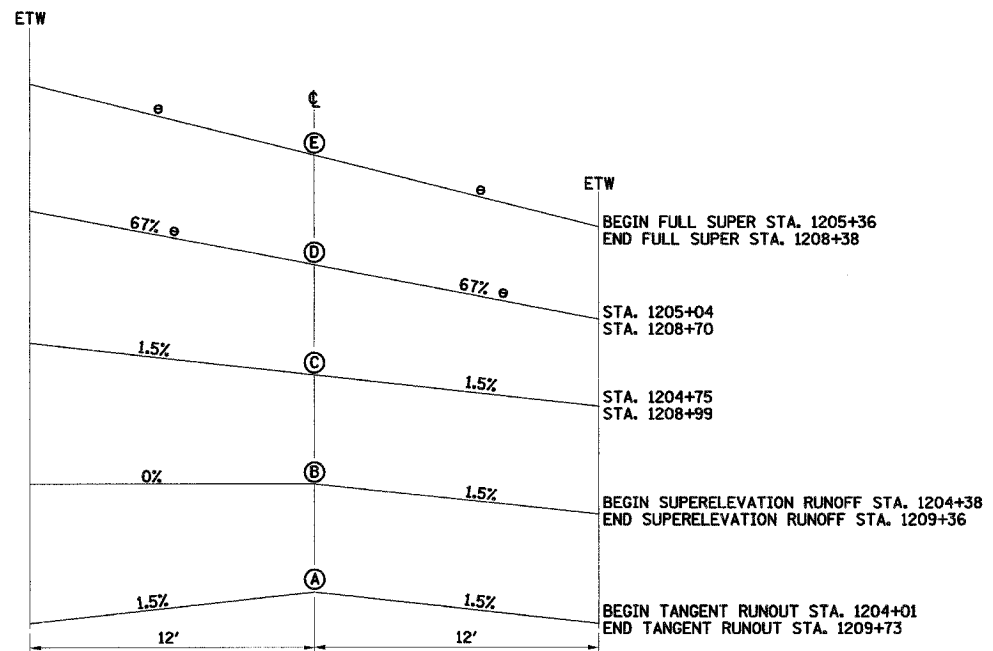

T.R. 2075 (STA. 1300+47 TO STA. 1306+07)

e = DESIGN SUPERELEVATION RATE = 4.0%

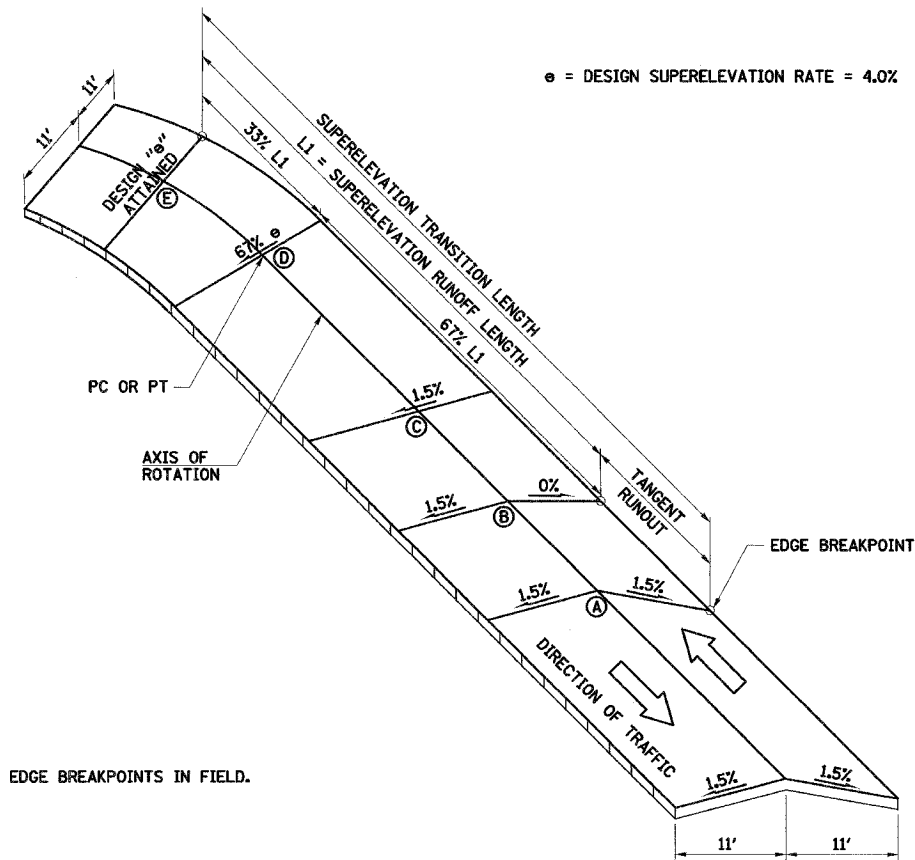

NOTE: ROUND ALL EDGE BREAKPOINTS IN FIELD.

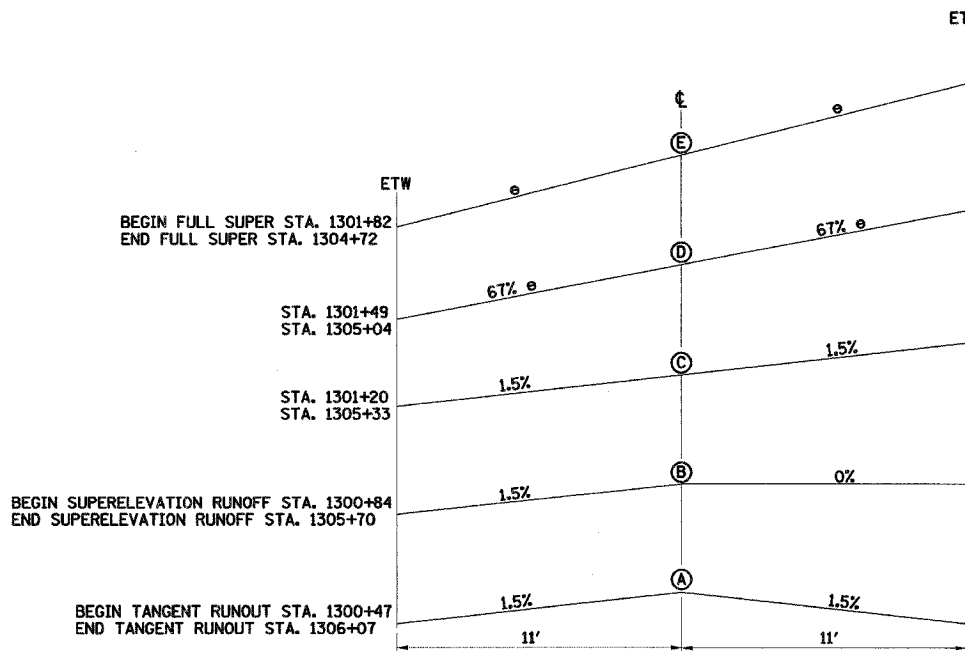

F.A.S. RTE.	SECTION	COUNTY	TOTAL SHEETS	SHEET NO.
1517	2)RS-3 (3)RS-4	MCLEAN	223	18
STA. _____ TO STA. _____		ILLINOIS FED. AID PROJECT		

66383

ILLINOIS DEPARTMENT OF TRANSPORTATION
F.A.S. 1517 (U.S. ROUTE 150)
SUPERELEVATION TRANSITION DETAILS

SCALE: VERT.
HORIZ.
DATE

DRAWN BY
CHECKED BY

DATE	BY	DATE

PLAN
NOTE BOOK NO. _____
SURVEYED _____
ALIGNMENT CHECKED _____
BY _____
ROAD FILE NAME _____

DATE	BY	DATE

PROFILE
NOTE BOOK NO. _____
SURVEYED _____
GRADES CHECKED _____
BY _____
PROFILE NOTATIONS SHOWN _____

COMPANY NAME: #COMPANY-NAME#
PROJECT CONTACT: #PROJECT-CONTACT#
CLIENT: #CLIENT#
DATE: #DATE#
SCALE: #SCALE#

SEEDING, CLASS I

ACRE	LOCATION	
U.S. ROUTE 150		
1.3	408+03 TO 424+50	LT
1.0	408+03 TO 424+50	RT
1.1	424+50 TO 439+00	LT
1.3	424+50 TO 439+00	RT
C.H. 36 NORTH		
1.1	1203+50 TO 1210+00	LT
0.6	1203+50 TO 1210+00	RT
T.R. 2075		
0.3	1300+20 TO 1306+00	LT
0.5	1300+20 TO 1306+00	RT
7.2	TOTAL	

SEEDING, CLASS II

ACRE	LOCATION	
U.S. ROUTE 150		
4.1	439+00 TO 509+50	LT
4.1	439+00 TO 509+50	RT
3.8	509+50 TO 596+00	LT
4.1	509+50 TO 596+00	RT
1.6	596+00 TO 627+50	LT
1.5	596+00 TO 627+50	RT
0.6	627+50 TO 641+00	LT
0.6	627+50 TO 641+00	RT
1.8	641+00 TO 680+00	LT
2.0	641+00 TO 680+00	RT
4.0	680+00 TO 754+50	LT
4.0	680+00 TO 754+50	RT
T.R. 2200		
0.2	1601+00 TO 1602+50	LT
0.1	1601+00 TO 1602+50	RT
T.R. 2325		
0.1	1700+50 TO 1702+50	LT
0.2	1700+50 TO 1702+50	RT
T.R. 2375		
0.1	1800+50 TO 1802+00	LT
0.1	1800+50 TO 1802+00	RT
T.R. 2400		
0.1	1900+50 TO 1902+00	LT
0.1	1900+50 TO 1902+00	RT
T.R. 2450		
0.1	2400+00 TO 2402+00	LT
0.1	2400+00 TO 2402+00	RT
33.4	TOTAL	

NITROGEN FERTILIZER NUTRIENT

POUND	LOCATION	
U.S. ROUTE 150		
369	439+00 TO 509+50	LT
369	439+00 TO 509+50	RT
342	509+50 TO 596+00	LT
369	509+50 TO 596+00	RT
144	596+00 TO 627+50	LT
135	596+00 TO 627+50	RT
54	627+50 TO 641+00	LT
54	627+50 TO 641+00	RT
162	641+00 TO 680+00	LT
180	641+00 TO 680+00	RT
360	680+00 TO 754+50	LT
360	680+00 TO 754+50	RT
T.R. 2200		
18	1601+00 TO 1602+50	LT
9	1601+00 TO 1602+50	RT
T.R. 2325		
9	1700+50 TO 1702+50	LT
18	1700+50 TO 1702+50	RT
T.R. 2375		
9	1800+50 TO 1802+00	LT
9	1800+50 TO 1802+00	RT
T.R. 2400		
9	1900+50 TO 1902+00	LT
9	1900+50 TO 1902+00	RT
T.R. 2450		
9	2400+00 TO 2402+00	LT
9	2400+00 TO 2402+00	RT
3006	TOTAL	

PHOSPHORUS FERTILIZER NUTRIENT

POUND	LOCATION	
U.S. ROUTE 150		
369	439+00 TO 509+50	LT
369	439+00 TO 509+50	RT
342	509+50 TO 596+00	LT
369	509+50 TO 596+00	RT
144	596+00 TO 627+50	LT
135	596+00 TO 627+50	RT
54	627+50 TO 641+00	LT
54	627+50 TO 641+00	RT
162	641+00 TO 680+00	LT
180	641+00 TO 680+00	RT
360	680+00 TO 754+50	LT
360	680+00 TO 754+50	RT
T.R. 2200		
18	1601+00 TO 1602+50	LT
9	1601+00 TO 1602+50	RT
T.R. 2325		
9	1700+50 TO 1702+50	LT
18	1700+50 TO 1702+50	RT
T.R. 2375		
9	1800+50 TO 1802+00	LT
9	1800+50 TO 1802+00	RT
T.R. 2400		
9	1900+50 TO 1902+00	LT
9	1900+50 TO 1902+00	RT
T.R. 2450		
9	2400+00 TO 2402+00	LT
9	2400+00 TO 2402+00	RT
3006	TOTAL	

POTASSIUM FERTILIZER NUTRIENT

POUND	LOCATION	
U.S. ROUTE 150		
369	439+00 TO 509+50	LT
369	439+00 TO 509+50	RT
342	509+50 TO 596+00	LT
369	509+50 TO 596+00	RT
144	596+00 TO 627+50	LT
135	596+00 TO 627+50	RT
54	627+50 TO 641+00	LT
54	627+50 TO 641+00	RT
162	641+00 TO 680+00	LT
180	641+00 TO 680+00	RT
360	680+00 TO 754+50	LT
360	680+00 TO 754+50	RT
T.R. 2200		
18	1601+00 TO 1602+50	LT
9	1601+00 TO 1602+50	RT
T.R. 2325		
9	1700+50 TO 1702+50	LT
18	1700+50 TO 1702+50	RT
T.R. 2375		
9	1800+50 TO 1802+00	LT
9	1800+50 TO 1802+00	RT
T.R. 2400		
9	1900+50 TO 1902+00	LT
9	1900+50 TO 1902+00	RT
T.R. 2450		
9	2400+00 TO 2402+00	LT
9	2400+00 TO 2402+00	RT
3006	TOTAL	

PLAN SURVEYED BY DATE
 NOTE BOOK NO. CHECKED BY
 RT. OF WAY CHECKED BY
 PART FILE NAME

PROFILE SURVEYED BY DATE
 ELEM. NOTED CHECKED BY
 STRUCTURE NOTATIONS CIPROG

COMPANY NAME: #COMPANY NAME#
 PROJECT CONTACT: #PROJECT CONTACT#
 CLIENT: #CLIENT#
 #DATE# #TIME#
 #FILE#

ILLINOIS DEPARTMENT OF TRANSPORTATION
F.A.S. 1517 (U.S. ROUTE 150)
SCHEDULE OF QUANTITIES
 (SHEET 1 OF 5)

SCALE: VERT. _____
 HORIZ. _____

DATE _____ DRAWN BY _____
 CHECKED BY _____

MULCH, METHOD 2

EROSION CONTROL BLANKET

EROSION CONTROL BLANKET

ACRE	LOCATION	
U.S. ROUTE 150		
1.3	408+03 TO 424+50	LT
1.0	408+03 TO 424+50	RT
1.1	424+50 TO 439+00	LT
1.3	424+50 TO 439+00	RT
4.1	439+00 TO 509+50	LT
4.1	439+00 TO 509+50	RT
3.8	509+50 TO 596+00	LT
4.1	509+50 TO 596+00	RT
1.6	596+00 TO 627+50	LT
1.5	596+00 TO 627+50	RT
0.6	627+50 TO 641+00	LT
0.6	627+50 TO 641+00	RT
1.8	641+00 TO 680+00	LT
2.0	641+00 TO 680+00	RT
4.0	680+00 TO 754+50	LT
4.0	680+00 TO 754+50	RT
C.H. 36 NORTH		
1.1	1203+50 TO 1210+00	LT
0.6	1203+50 TO 1210+00	RT
T.R. 2075		
0.3	1300+20 TO 1306+00	LT
0.5	1300+20 TO 1306+00	RT
T.R. 2200		
0.2	1601+00 TO 1602+50	LT
0.1	1601+00 TO 1602+50	RT
T.R. 2325		
0.1	1700+50 TO 1702+50	LT
0.2	1700+50 TO 1702+50	RT
T.R. 2375		
0.1	1800+50 TO 1802+00	LT
0.1	1800+50 TO 1802+00	RT
T.R. 2400		
0.1	1900+50 TO 1902+00	LT
0.1	1900+50 TO 1902+00	RT
T.R. 2450		
0.1	2400+00 TO 2402+00	LT
0.1	2400+00 TO 2402+00	RT
40.6	TOTAL	

SQ YD	LOCATION	
U.S. ROUTE 150		
18	409+65	LT
18	421+90	RT
18	422+45	RT
19	424+20	LT
19	425+15	LT
16	427+00	LT
18	427+90	LT
18	428+38	LT
16	429+00	LT
16	431+00	LT
16	433+00	LT
16	435+00	LT
18	437+00	LT
21	438+15	LT
21	438+73	LT
18	441+36	RT
18	442+48	RT
18	446+30	RT
18	446+87	RT
18	447+71	LT
18	448+40	LT
18	457+97	LT
18	458+15	RT
18	458+59	LT
18	458+72	RT
19	472+47	LT
19	472+75	RT
19	473+25	LT
19	473+60	RT
18	493+41	LT
18	494+00	LT
25	501+04	LT
25	501+04	RT
18	502+34	RT
18	503+37	RT
18	507+66	LT
18	508+32	LT
18	508+57	RT
18	508+57	RT
18	509+25	RT
18	510+36	RT
18	532+88	RT
18	533+42	RT
18	536+95	LT
18	537+58	LT
18	539+65	RT
18	540+20	RT
18	533+71	LT
18	554+29	LT
26	560+42	LT
26	560+42	RT
18	564+20	LT
18	564+32	RT
18	564+68	LT
18	564+80	RT
18	567+80	LT
18	568+07	LT
18	584+96	LT
18	585+44	LT
18	585+57	RT
18	586+25	RT
18	588+09	RT
18	588+54	RT
18	595+00	LT
18	596+36	LT
18	603+64	RT
18	604+08	RT
18	604+69	RT
18	605+24	RT
18	610+64	LT
18	611+06	LT
18	619+82	LT
18	620+33	LT
18	626+82	RT
18	627+83	RT
25	627+93	LT
25	627+93	RT
18	639+30	RT

SQ YD	LOCATION	
U.S. ROUTE 150		
18	640+52	LT
18	641+75	LT
18	645+20	RT
18	653+55	LT
18	654+00	LT
18	655+94	LT
18	656+47	LT
19	672+08	RT
19	672+55	RT
18	679+25	LT
18	679+65	RT
18	679+75	LT
18	680+90	RT
18	695+24	LT
18	695+77	LT
18	698+24	LT
18	698+24	RT
18	698+80	RT
18	698+82	LT
18	700+33	LT
16	700+95	LT
18	702+12	LT
18	702+73	LT
25	706+25	LT
25	706+44	RT
18	714+16	LT
18	714+81	LT
18	722+38	RT
18	722+90	RT
18	727+05	RT
18	727+57	RT
18	740+84	LT
18	741+45	LT
18	746+85	LT
18	747+48	LT
18	751+50	RT
18	752+06	RT
C.H. 36 NORTH		
18	1205+38	LT
18	1205+38	RT
T.R. 2075		
18	1300+50	RT
18	1301+11	RT
18	1301+96	RT
18	1302+86	RT
18	1302+90	RT
18	1303+23	RT
18	1303+46	RT
18	1303+92	RT
18	1304+40	RT
18	1305+10	RT
2348	TOTAL	

TEMPORARY EROSION CONTROL SEEDING
5 APPLICATIONS AT 100 POUNDS PER ACRE

POUND	LOCATION	
U.S. ROUTE 150		
650	408+03 TO 424+50	LT
500	408+03 TO 424+50	RT
550	424+50 TO 439+00	LT
650	424+50 TO 439+00	RT
2050	439+00 TO 509+50	LT
2050	439+00 TO 509+50	RT
1900	509+50 TO 596+00	LT
2050	509+50 TO 596+00	RT
800	596+00 TO 627+50	LT
750	596+00 TO 627+50	RT
300	627+50 TO 641+00	LT
300	627+50 TO 641+00	RT
900	641+00 TO 680+00	LT
1000	641+00 TO 680+00	RT
2000	680+00 TO 754+50	LT
2000	680+00 TO 754+50	RT
C.H. 36 NORTH		
550	1203+50 TO 1210+00	LT
300	1203+50 TO 1210+00	RT
T.R. 2075		
150	1300+20 TO 1306+00	LT
250	1300+20 TO 1306+00	RT
T.R. 2200		
100	1601+00 TO 1602+50	LT
50	1601+00 TO 1602+50	RT
T.R. 2325		
50	1700+50 TO 1702+50	LT
100	1700+50 TO 1702+50	RT
T.R. 2375		
50	1800+50 TO 1802+00	LT
50	1800+50 TO 1802+00	RT
T.R. 2400		
50	1900+50 TO 1902+00	LT
50	1900+50 TO 1902+00	RT
T.R. 2450		
50	2400+00 TO 2402+00	LT
50	2400+00 TO 2402+00	RT
20300	TOTAL	

PLAN

DATE

BY

SURVEYED

ALIGNED

CHECKED

NO. _____

NOTE BOOK

NO. _____

PROFILE

DATE

BY

SURVEYED

GRADES

CHECKED

NO. _____

NOTE BOOK

NO. _____

COMPANY NAME: #COMPANY NAME#

PROJECT CONTACT: #PROJECT CONTACT#

CLIENT: #CLIENT#

DATE: #DATE#

FILE#

ILLINOIS DEPARTMENT OF TRANSPORTATION

F.A.S. 1517 (U.S. ROUTE 150)

SCHEDULE OF QUANTITIES

(SHEET 2 OF 5)

SCALE: VERT. _____

HORIZ. _____

DATE _____

DRAWN BY _____

CHECKED BY _____

F.A.S. RTE.	SECTION	COUNTY	TOTAL SHEETS	SHEET NO.
1517 (2)RS-3 (3)RS-4		MCLEAN	223	22
STA.	TO STA.			
FED. ROAD DIST. NO.	ILLINOIS	FED. AID PROJECT		

66383

INLET AND PIPE PROTECTION

EACH	LOCATION U.S. ROUTE 150		
1	410+50	15'	LT
1	410+50	15'	RT
1	410+59	15'	LT
1	410+59	15'	RT
1	413+00	15'	LT
1	413+00	15'	RT
1	415+50	15'	LT
1	415+50	15'	RT
1	418+00	15'	LT
1	418+00	15'	RT
1	421+90	26'	RT
1	423+35	15.6'	LT
1	423+35	15'	RT
1	424+20	75'	LT
1	425+00	15'	RT
1	427+00	15'	LT
1	427+00	15'	RT
1	427+74	36'	LT
1	429+00	15'	LT
1	429+00	15'	RT
1	431+00	15'	LT
1	431+00	15'	RT
1	433+00	15'	LT
1	433+00	15'	RT
1	435+00	15'	LT
1	435+00	15'	RT
1	437+00	15'	LT
1	437+00	15'	RT
1	437+00	22'	RT
1	437+31.88	31.1'	RT
1	438+15	32'	LT
1	441+36	38'	RT
1	442+40	34'	LT
1	446+30	37'	RT
1	447+71	40'	RT
1	457+97	31'	LT
1	458+15	33'	RT
1	472+47	30'	LT
1	472+75	27'	RT
1	476+00	33'	LT
1	494+00	29'	LT
1	501+04	29'	RT
1	503+37	34'	RT
1	508+32	40'	LT
1	509+25	58'	RT
1	510+36	34'	RT
1	532+69	33'	RT
1	533+42	45'	RT
1	537+58	32'	LT
1	540+20	31'	RT
1	554+29	35'	LT
1	560+42	30'	LT
1	564+68	27'	LT
1	564+80	28'	RT
1	568+07	26'	LT
1	584+96	30'	LT
1	585+57	36'	RT
1	588+09	35'	RT
1	592+00	33'	LT
1	596+36	32'	LT
1	604+08	30'	RT
1	605+24	31'	RT
1	610+64	33'	LT
1	613+34	29'	LT
1	613+34	29'	RT
1	620+33	30'	LT
1	626+82	34'	RT
1	627+93	40'	RT
1	639+30	27'	RT
1	640+52	32'	LT
1	641+00	13'	RT
1	643+00	13'	RT
1	653+55	30'	LT
1	655+94	30'	LT
1	662+34	33'	LT
1	672+51	32'	RT
1	679+72	32'	LT
1	680+90	34'	RT
1	695+29	31'	LT
1	698+29	30'	LT
1	698+32	30'	RT
1	700+33	32'	LT
1	702+12	35'	LT
1	706+26	43'	LT
1	714+16	36'	LT
1	722+38	34'	RT
1	725+68	33'	LT

INLET AND PIPE PROTECTION

EACH	LOCATION U.S. ROUTE 150		
1	727+57	37'	RT
1	741+45	38'	LT
1	747+48	34'	LT
1	751+50	27'	RT
SEMINARY STREET			
1	1100+75	48'	RT
1	1100+76	21'	RT
1	1100+77	26'	LT
C.H. 36 NORTH			
1	1205+38	39'	LT
T.R. 2075			
1	1300+50	22'	RT
1	1301+96	25'	RT
1	1302+90	26'	RT
1	1303+46	28'	RT
1	1304+40	35'	RT
100	TOTAL		

STONE DUMPED RIPRAP, CLASS A4

TON	LOCATION U.S. ROUTE 150		
162	408+03	LT	
54	442+60	LT	
46	442+60	RT	
24	476+00	LT	
21	476+00	RT	
152	489+00	LT	
152	489+00	RT	
167	491+00	LT	
167	491+00	RT	
17	532+69	LT	
25	532+69	RT	
19	592+00	LT	
23	592+00	RT	
14	662+34	LT	
14	662+34	RT	
26	725+68	LT	
18	725+68	RT	
1101	TOTAL		

FILTER FABRIC

SQ YD	LOCATION U.S. ROUTE 150		
178	408+03	LT	
59	442+60	LT	
50	442+60	RT	
26	476+00	LT	
23	476+00	RT	
167	489+00	LT	
167	489+00	RT	
184	491+00	LT	
184	491+00	RT	
18	532+69	LT	
27	532+69	RT	
21	592+00	LT	
25	592+00	RT	
16	662+34	LT	
16	662+34	RT	
28	725+68	LT	
20	725+68	RT	
1209	TOTAL		

MANHOLES TO BE ADJUSTED

EACH	LOCATION		
1	752+93	7.7'	RT
1	TOTAL		

STEEL PLATE BEAM GUARDRAIL, TYPE B

FOOT	LOCATION		
100	408+34 RT TO 1100+32 LT		SEMINARY STREET
100	TOTAL		

TRAFFIC BARRIER TERMINAL, TYPE 6A

EACH	LOCATION		
1	408+03 TO 408+34 LT		
1	408+03 TO 408+34 RT		
2	TOTAL		

TRAFFIC BARRIER TERMINAL TYPE 1, SPECIAL (TANGENT)

EACH	LOCATION		
1	1099+82 TO 1100+32 LT		SEMINARY STREET
1	TOTAL		

TRAFFIC BARRIER TERMINAL TYPE 1, SPECIAL (FLARED)

EACH	LOCATION		
1	408+34 TO 408+84 LT		
1	TOTAL		

GUARDRAIL REMOVAL

FOOT	LOCATION		
88	408+03 TO 408+88 LT		
75	408+03 TO 408+70 RT		
163	TOTAL		

PLAN SURVEYED BY DATE
 CHECKED BY DATE
 ALIGNED BY DATE
 FILE NAME

PROFILE SURVEYED BY DATE
 CHECKED BY DATE
 GRADES CHECKED BY DATE
 STRUCTURE NOTATION: BHPD

COMPANY NAME: #COMPANY-NAME#
 PROJECT CONTACT: #PROJECT-CONTACT#
 CLIENT: #CLIENT#
 DATE: #DATE#
 TIME: #TIME#
 FILE#

ILLINOIS DEPARTMENT OF TRANSPORTATION
F.A.S. 1517 (U.S. ROUTE 150)
SCHEDULE OF QUANTITIES
(SHEET 4 OF 5)

SCALE: VERT. _____
 DATE _____ HORIZ. _____

DRAWN BY _____
 CHECKED BY _____

F.A.S. RTE.	SECTION	COUNTY	TOTAL SHEETS	SHEET NO.
1517	2)RS-3 (3)RS-4	MCLEAN	223	24
STA.		TO STA.		
FED. ROAD DIST. NO.		ILLINOIS FED. AID PROJECT		
66383				

LOCATION	SUBBASE * GRANULAR MAT. TYPE A, 4"		SUBBASE GRANULAR MAT. TYPE C, 4"		AGGREGATE BASE COURSE TYPE B, 8"	AGGREGATE SURFACE COURSE TYPE B	AGGREGATE FOR TEMPORARY ACCESS	BITUMINOUS MATERIALS (PRIME COAT)	AGGREGATE (PRIME COAT)	BITUMINOUS SURFACE REM. (VAR. DEPTH)	BITUMINOUS SURFACE REM. BUTT JOINT	TEMPORARY RAMP	PCC DRIVEWAY PAVEMENT 6"	INCIDENTAL BITUMINOUS SURFACING	PAVEMENT REMOVAL	DRIVEWAY PAVEMENT REMOVAL
	(SQ YD)	(SQ YD)	LEFT	RIGHT												
U.S. ROUTE 150																
408+02.77 TO 419+83.00	1543							231	5.8	1179	147	29				
419+83.00 TO 438+84.82	2159							372	9.3	3606						
438+84.82 TO 449+81.00		416	445					215	5.4	2680						
449+81.00 TO 471+70.00		852	852					429	10.8	5351						
471+70.00 TO 483+42.00		458	455					230	5.8	2865						
483+42.00 TO 489+48.00		236	236					119	3.0	1482						
489+48.00 TO 498+23.00		340	341					172	4.3	2139						
498+23.00 TO 502+75.00		176	176					89	2.3	1105						
502+75.00 TO 513+33.00		414	434					207	5.2	2587						
513+33.00 TO 523+63.00		401	401					202	5.1	2518						
523+63.00 TO 535+41.00		457	461					231	5.8	2880						
535+41.00 TO 618+62.00		3228	3234					1626	40.7	20316						
618+62.00 TO 630+10.00		450	478					227	5.7	2831						
630+10.00 TO 638+81.00		339	339					171	4.3	2130						
638+81.00 TO 647+69.00		373	822					174	4.4	2171						
647+69.00 TO 678+04.00		1182	1181					594	14.9	7419						
678+04.00 TO 689+51.00		446	473					225	5.7	2804						
689+51.00 TO 705+84.00		636	636					320	8.0	3992						
705+84.00 TO 717+82.00		469	465					235	5.9	2929						
717+82.00 TO 736+20.00		716	716					360	9.0	4493						
736+20.00 TO 746+08.00		382	388					194	4.9	2416						
746+08.00 TO 754+51.18		328	328					165	4.2	2062	147	25				
SUBTOTAL	3702	12299	12861	0	0	0	6788	170.5	81955	294	54	0	0	0	0	0
SEMINARY STREET																
1100+00.00 TO 1101+31.14	49							47	1.2	576						
DOOLEY AVENUE				348				131	0.7					35.6	418	
C.H. 36 NORTH																
1203+00.00 TO 1210+00.00	1715							798	4.3		123	13			1610	
T.R. 2075																
1300+20.00 TO 1306+43.18	1065	224	230					734	3.9	428		18			500	
C.H. 36 SOUTH																
1500+00.00 TO 1502+56.21	1140		71					417	2.3						733	
T.R. 2200																
1601+00.00 TO 1602+98.36	760	79	68					285	1.6						571	
T.R. 2325																
1700+00.00 TO 1702+50.00	417	88	96					34	0.9		89	9				
T.R. 2375																
1800+50.00 TO 1802+39.72	232	74	69					34	0.9		116	9				
T.R. 2400																
1900+00.00 TO 1901+50.00	186	53	58					31	0.8		106	11				
T.R. 2450																
2400+50.00 TO 2402+32.08	636	70	64					239	1.3						70	
SUBTOTAL - SIDEROADS	6200	588	656	348	0	0	2750	17.9	1004	434	60	0	35.6	3902	0	0
DRIVEWAYS																
SUBTOTAL**	0	0	0	2167	1989.0	2828.1	737	0	0	0	0	154	217.5	0	1636	0
TOTAL	9902	26404	2515	1989.0	2828.1	10275	188.4	82959	728	114	154	253.1	3902	1636	0	0

* PAVEMENT PATCHING AND ASSOCIATED SUBBASE GRANULAR MATERIAL TYPE A, 4" NOT INCLUDED. SEE PATCHING SCHEDULE FOR QUANTITIES AND LOCATIONS.
 ** SEE DRIVEWAY SCHEDULE FOR INDIVIDUAL DRIVEWAY QUANTITIES.

ILLINOIS DEPARTMENT OF TRANSPORTATION
F.A.S. 1517 (U.S. ROUTE 150)
PAVEMENT SCHEDULE
(SHEET 1 OF 2)

SCALE: VERT. _____
 HORIZ. _____
 DATE _____ DRAWN BY _____
 CHECKED BY _____

PLAN SURVEYED _____ BY _____ DATE _____
 NOTE BOOK _____
 NO. _____
 CHECKED _____
 DATE _____

PROFILE SURVEYED _____ BY _____ DATE _____
 NOTE BOOK _____
 NO. _____
 CHECKED _____
 DATE _____

COMPANY NAME: #COMPANY NAME#
 PROJECT CONTACT: #PROJECT CONTACT#
 CLIENT: #CLIENT#
 DATE: #DATE#
 FILE: #FILE#

LOCATION	COMBINATION CONCRETE CURB AND GUTTER REMOVAL (FOOT)		BITUMINOUS SHOULDER REMOVAL (SQ YD)		AGGREGATE SHOULDERS TYPE B (TON)		BITUMINOUS SHOULDERS SUPERPAVE 6 1/2" (SQ YD)		COMBINATION CONCRETE CURB AND GUTTER TYPE B6.24 (FOOT)		COMBINATION CONCRETE CURB AND GUTTER TYPE M4.24 (FOOT)		BITUMINOUS CONCRETE BASE COURSE WIDENING SUPERPAVE 9" (SQ YD)		BITUMINOUS BASE COURSE SUPERPAVE 5 3/4" (SQ YD)	BITUMINOUS CONCRETE SURFACE COURSE SUPERPAVE MIX "C", N50 (TON)	BITUMINOUS CONCRETE BINDER COURSE SUPERPAVE IL-19.0, N50 (TON)	LEVELING BINDER (MACH. METHOD) SUPERPAVE N50 (TON)
	LEFT	RIGHT	LEFT	RIGHT	LEFT	RIGHT	LEFT	RIGHT	LEFT	RIGHT	LEFT	RIGHT	LEFT	RIGHT				
U.S. ROUTE 150																		
408+02.77 TO 419+83.00	1060	1185	858	700			143	25	1062	1108	26	128	263	263		300.6		1800.6
419+83.00 TO 438+84.82			419	95					1994	2144			435	434		481.6		625.4
438+84.82 TO 449+81.00			183	183	201.7	135.3	357	382								287.0		281.7
449+81.00 TO 471+70.00			365	365	406.3	406.0	730	730								572.1		261.4
471+70.00 TO 483+42.00			196	196	214.3	212.2	393	390								306.3		185.8
483+42.00 TO 489+48.00			101	101	115.1	115.1	202	202								158.4		66.0
489+48.00 TO 498+23.00			146	146	156.5	166.6	292	293								228.7		157.9
498+23.00 TO 502+75.00			76	76	85.8	79.5	151	151								118.2		55.2
502+75.00 TO 513+33.00			177	177	192.8	142.8	355	372								282.6		172.1
513+33.00 TO 523+63.00			172	172	195.6	195.6	344	344								269.2		111.9
523+63.00 TO 535+41.00			197	197	222.2	217.5	391	395								307.9		220.5
535+41.00 TO 618+52.00			1386	1386	1476.8	1523.5	2771	2772								2178.0		1265.7
618+52.00 TO 630+10.00			193	193	211.7	175.3	386	409								308.7		282.7
630+10.00 TO 638+81.00			146	146	165.4	165.4	291	291								227.7		110.6
638+81.00 TO 647+69.00			148	148	123.9	64.1	319	632		550						263.8		216.6
647+69.00 TO 678+04.00			506	506	565.2	554.2	1013	1013								793.2		457.0
678+04.00 TO 689+51.00			192	192	207.9	173.2	382	405								305.8		246.8
689+51.00 TO 705+84.00			273	273	275.9	293.9	545	545								426.8		179.8
705+84.00 TO 717+82.00			200	200	219.5	226.2	402	398								313.1		180.9
717+82.00 TO 736+20.00			307	307	349.0	330.4	613	613								480.4		205.2
736+20.00 TO 746+08.00			165	165	176.2	189.7	327	333								258.2		212.1
746+08.00 TO 754+51.18			141	141	150.9	150.6	282	282								220.4		94.9
SUBTOTAL	1060	1185	6547	6065	5712.7	5517.1	10689	10977	3056	3802	26	128	698	697	0	9068.7	0	7390.8
SEMINARY STREET																		
1100+00.00 TO 1101+31.14																69	54.2	52.0
DOOLEY AVENUE																		
C.H. 36 NORTH																		
1203+00.00 TO 1210+00.00					139.3	139.5							16	6	1525	179.1	192.2	136.2
T.R. 2075																		
1300+20.00 TO 1306+43.18					43.6	45.1	192	197					34	28	1000	160.7	126.0	80.2
C.H. 36 SOUTH																		
1500+00.00 TO 1502+56.21						13.9		61							1052	93.5	132.6	
T.R. 2200																		
1601+00.00 TO 1602+98.36					15.4	13.6	67	58							732	67.6	92.3	
T.R. 2325																		
1700+00.00 TO 1702+50.00					17.5	15.6	75	82					263	104		75.0		323.8
T.R. 2375																		
1800+50.00 TO 1802+39.72					14.7	13.9	63	59					63	133		57.4		192.9
T.R. 2400																		
1900+00.00 TO 1901+50.00					6.8	11.6	45	50					100	55		48.9		97.8
T.R. 2450																		
2400+50.00 TO 2402+32.08					14.0	13.0	60	55							612	56.9	77.2	
SUBTOTAL - SIDEROADS	0	0	0	0	251.3	266.2	502	562	0	0	0	0	476	395	4921	793.3	620.3	882.9
DRIVEWAYS																		
SUBTOTAL**	0	0	0	0	22.9	0	0	0	0	0	0	0	0	0	0	0	0	0
TOTAL	2245	2245	12612	12612	11770.2	11770.2	22730	22730	6858	6858	154	154	2266	2266	4921	9862.0	620.3	8273.7

* PAVEMENT PATCHING AND ASSOCIATED SUBBASE GRANULAR MATERIAL TYPE A, 4" NOT INCLUDED. SEE PATCHING SCHEDULE FOR QUANTITIES AND LOCATIONS.
 ** SEE DRIVEWAY SCHEDULE FOR INDIVIDUAL DRIVEWAY QUANTITIES.

ILLINOIS DEPARTMENT OF TRANSPORTATION
F.A.S. 1517 (U.S. ROUTE 150)
PAVEMENT SCHEDULE
(SHEET 2 OF 2)

SCALE: VERT. _____
 HORIZ. _____
 DATE _____

DRAWN BY _____
 CHECKED BY _____

PLAN
 SURVEYED _____
 ALIGNMENT CHECKED _____
 GRADES CHECKED _____
 PAVED FILE NAME _____
 NO. _____

PROFILE
 SURVEYED _____
 GRADES CHECKED _____
 STRUCTURE NOTATIONS (S/W) _____
 NO. _____

COMPANY NAME: #COMPANY.NAME#
 PROJECT CONTACT: #PROJECT.CONTACT#
 CLIENT: #CLIENT#
 DATE: #DATE#
 BY: #BY#

DRIVEWAY LOCATION	PE/CE	EXISTING SURFACE TYPE	DRIVEWAY PAVEMENT REMOVAL (SQ YD)	PCC DRIVEWAY PAVEMENT 6" (SQ YD)	INCIDENTAL BITUMINOUS SURFACING (TON)	BITUMINOUS MATERIALS (PRIME COAT) (GAL)	AGGREGATE BASE COURSE TYPE B, 8" (SQ YD)	AGGREGATE SURFACE COURSE TYPE B (TON)	AGGREGATE FOR TEMPORARY ACCESS (TON)	AGGREGATE SHOULDERS TYPE B (TON)	
										LEFT	RIGHT
U.S. ROUTE 150											
419+96 LT	PE	AGG.			3.2	11	28	18.2	31.0		
421+86 LT	CE	BIT.	93		9.0	30	80		36.5		
422+18 RT	PE	BIT.	34		3.5	12	31		14.2		
422+97 LT	CE	BIT.	190		9.0	30	80		36.5		
428+04 LT	FE	AGG.						53.3	53.3		
428+05 RT	FE	AGG.						22.8	22.8		
432+67 RT	CE	AGG.			5.6	19	50		22.8		
433+84 RT	PE	AGG.			5.1	17	45		20.5		
438+44 LT	FE	AGG.						53.7	53.7		
441+87 RT	CE	BIT.	451		59.5	200	531		241.7	11.0	11.9
445+86 RT	FE	AGG.						67.4	67.4		
446+59 RT - M	PE	BIT. APRON	52		4.3	15	45		19.2	30.5	
448+06 RT	FE	AGG.						61.5	61.5		
458+28 LT	FE	AGG.						55.6	55.6		
458+42 RT	FE	AGG.						57.8	57.8		
472+78 LT	FE	BIT.	84					55.6	55.6		
473+30 RT	FE	AGG.						61.5	61.5		
493+70 LT	FE	AGG.						49.2	49.2		
502+66 RT	FE	AGG.						55.1	55.1		
503+10 RT - M	PE	BIT. APRON	76		4.5	15	46		18.7	18.7	
507+99 LT	FE	AGG.						55.6	55.6		
508+94 RT	PE	AGG.			3.1	11	27		25.1	37.4	
533+07 RT - M	PE	BIT. APRON	45		4.4	15	45		21.0	32.8	
537+26 LT	FE	AGG.						61.5	61.5		
539+92 RT	FE	AGG.						55.1	55.1		
554+00 LT	FE	AGG.						61.5	61.5		
564+44 LT	FE	AGG.						43.3	43.3		
564+56 RT	FE	AGG.						43.3	43.3		
567+84 LT - M	PE	BIT. APRON	48		5.2	18	51		16.9	32.4	
585+20 LT	FE	AGG.						55.1	55.1		
585+87 RT	FE	AGG.						66.9	66.9		
588+28 RT - M	PE	BIT. APRON	9		4.4	15	45		16.9	28.7	
603+85 RT - M	PE	BIT. APRON	35		4.6	16	47		17.8	29.6	
604+96 RT	FE	AGG.						56.0	56.0		
610+86 LT - M	PE	BIT. APRON	31		4.3	15	44		16.0	27.4	
620+09 LT - M	PE	BIT.	80		9.5	32	90		32.8		
640+40 RT	FE	GRASS						14.2	14.2		
642+74 RT	PE	BIT. APRON	39		2.7	9	24		11.0		
653+78 LT - M	PE	AGG.			5.9	20	61		18.3	30.5	
656+21 LT - M	PE	AGG.			6.0	20	62		19.2	31.9	
672+30 RT - M	PE	BIT. APRON	33		4.5	15	46		16.4	27.8	
679+50 LT	FE	AGG.						55.6	55.6		
695+52 LT - M	PE	AGG.			6.4	22	66		24.2	38.7	
698+53 LT	FE	AGG.						55.1	55.1		
698+53 RT	FE	AGG.						55.1	55.1		
700+64 LT	FE	AGG.						55.1	55.1		
702+43 LT	FE	AGG.						55.1	55.1		
714+49 LT	FE	AGG.						55.1	55.1		
722+64 RT	FE	AGG.						55.1	55.1		
727+31 RT	FE	AGG.						55.1	55.1		
741+14 LT	FE	AGG.						55.6	55.6		
747+16 LT	FE	AGG.						55.6	55.6		
751+79 RT	CE	BIT.	223		12.7	43	113		51.5		
SUBTOTAL - U.S. ROUTE 150			1503	0	177.4	600	1657	1906.4	2523.4	11.0	11.9
I.R. 2075											
1300+73 RT - M	PE	PCC	57	55	1.2	4	65		25.1		
1302+36 RT - M	PE	PCC	76	99	1.3	5	110		45.1		
1303+06.5 RT	CE	AGG.			6.1	21	54		24.6		
1303+69 RT	CE	AGG.			16.5	56	147		66.9		
1304+79 RT	CE	N/A			15.0	51	134		61.0		
I.R. 2325											
1700+82 RT	FE	AGGREGATE						46.5	46.5		
I.R. 2400											
1901+17 LT	FE	AGGREGATE						35.5	35.5		
SUBTOTAL - SIDE ROADS			133	154	40.1	137	510	82.0	304.7		
TOTAL			1636	154	217.5	737	2167	1988.4	2828.1	11.0	11.9

NOTES:
1. EXISTING AGGREGATE ENTRANCE REMOVAL SHALL BE INCLUDED IN THE CONTRACT UNIT PRICE PER CUBIC YARD FOR EARTH EXCAVATION.
2. "M" DENOTES QUANTITIES INCLUDE INCIDENTAL BITUMINOUS SURFACING AND AGGREGATE BASE COURSE TYPE B, 8" REQUIRED FOR MAILBOX TURNOUT.

ILLINOIS DEPARTMENT OF TRANSPORTATION
F.A.S. 1517 (U.S. ROUTE 150)
DRIVEWAY SCHEDULE
SCALE: VERT. _____
HORIZ. _____
DATE _____
DRAWN BY _____
CHECKED BY _____

PLAN
SURVEYED _____
NOTE BOOK _____
NO. _____
CHECKED _____
DATE _____

PROFILE
SURVEYED _____
NOTE BOOK _____
NO. _____
CHECKED _____
DATE _____

COMPANY NAME: #COMPANY NAME#
PROJECT CONTACT: #PROJECT CONTACT#
CLIENT: #CLIENT#
DATE: #DATE#
FILE: #FILE#

TREE REMOVAL SCHEDULE

LOCATION	TREE REMOVAL (6 TO 15 UNITS) (UNITS)	TREE REMOVAL (OVER 15 UNITS) (UNITS)
408+08.28 42.3 LT	6	
408+12.91 46.1 LT	8	
408+13.80 39.9 LT	8	
408+14.95 50.3 LT	6	
408+18.28 42.6 LT	10	
408+23.36 42.8 LT	10	
408+36.15 39.2 LT	8	
408+51.67 47.3 LT		18
408+65.85 45.2 LT	6	
408+78.02 45.9 LT	6	
408+81.36 44.4 LT		36
409+00.94 40.5 LT		30
409+02.49 38.6 LT	12	
409+20.28 40.8 LT	6	
409+21.81 32.8 LT		22
409+23.61 33.3 LT	8	
409+26.39 34.5 LT	8	
409+38.56 31.5 LT	6	
414+27.17 28.8 RT		42
414+30.33 29.8 RT	6	
414+33.69 28.5 RT		24
414+39.55 30.4 RT	6	
414+62.63 31.0 RT	8	
414+96.14 35.4 RT	12	
415+05.66 34.3 RT	12	
504+08.67 31.4 RT	8	
601+37.83 48.3 RT		18
601+49.32 37.9 RT		24
603+42.45 41.8 RT		24
604+27.19 40.0 RT		24
606+11.97 33.4 RT		48
608+38.79 47.7 LT	6	
608+51.14 46.4 LT	6	
608+95.73 38.5 LT	8	
609+07.06 37.5 LT	8	
609+18.65 38.1 LT	10	
609+42.65 37.9 LT	6	
609+55.70 37.2 LT	8	
653+10.48 36.1 LT		48
653+64.59 38.8 LT		60
655+11.76 42.2 LT		36
660+53.12 29.9 RT		36
672+72.75 40.8 RT	8	
1303+66.84 16.9 LT	8	
1303+70.83 23.9 LT	8	
1303+78.52 33.1 RT		18
1303+85.63 25.2 LT	8	
SUBTOTAL	244	508
10% GROWTH FACTOR	24	51
TOTAL	268	559

EARTHWORK SCHEDULE

LOCATION	EARTH EXCAVATION (CU YD)	EARTH EXCAVATION ADJUSTED FOR SHRINKAGE (CU YD)	SECTION TOTALS EMBANKMENT (CU YD)	EARTHWORK BALANCE WASTE (+) OR SHORTAGE (-) (CU YD)
U.S. ROUTE 150				
408+03 TO 424+00	208	156	1014	-858
424+00 TO 438+00	2354	1766	796	970
438+00 TO 510+00	17015	12761	2010	10751
510+00 TO 596+00	15496	11622	2971	8651
596+00 TO 627+00	8956	6717	678	6039
627+00 TO 641+00	1977	1483	511	972
641+00 TO 680+00	8443	6332	872	5460
680+00 TO 754+50	19536	14652	2462	12190
SUBTOTAL	73985	55489	11314	44175
SEMINARY STREET				
1100+00.00 TO 1101+31.14	46	35	11	24
C.H. 36 NORTH				
1203+00.00 TO 1210+00.00	2289	1717	211	1506
T.R. 2075				
1300+20.00 TO 1306+43.18	1638	1229	241	988
C.H. 36 SOUTH				
1500+00.00 TO 1502+56.21	498	374	13	361
T.R. 2200				
1601+00.00 TO 1602+98.36	285	214	3	211
T.R. 2325				
1700+00.00 TO 1702+50.00	69	52	72	-20
T.R. 2375				
1800+50.00 TO 1802+39.72	105	79	16	63
T.R. 2400				
1900+00.00 TO 1901+50.00	166	125	2	123
T.R. 2450				
2400+50.00 TO 2402+32.08	290	218	1	217
TOTAL	79371	59528	11884	47644

SHRINKAGE FACTORS
EARTH EXCAVATION 25%

PLAN SURVEYED BY: _____ DATE: _____
 PLOTTED BY: _____
 R.I. OF WAY CHECKED BY: _____
 CADD FILE NAME: _____

PROFILE SURVEYED BY: _____ DATE: _____
 PLOTTED BY: _____
 BAL. NOTED BY: _____
 STRUCTURE NOTATIONS CH'VD BY: _____

COMPANY NAME: SET, INC.
 PROJECT CONTACT: TONY SIMONIS
 CLIENTS: JDD
 01/8/2006 06:06:56 PM
 Y:\Jobs\Smith\2006\00024\cadd\Tree-rem.dgn

ILLINOIS DEPARTMENT OF TRANSPORTATION
F.A.S. 1517 (U.S. ROUTE 150)
TREE REMOVAL SCHEDULE
EARTHWORK SCHEDULE

SCALE: VERT. _____
 HORIZ. _____
 DATE _____

DRAWN BY _____
 CHECKED BY _____

DATE BY
 SURVEYED CHECKED
 ALIGNMENT CHECKED
 PLAN NOTE BOOK NO.
 DATE BY
 SURVEYED CHECKED
 PROFILE (S.A., N.O.D.)
 CHECKED
 DATE BY

LOCATION	SEE DETAIL	STANDARD NUMBER	SIGN AREA TYPE 1 (SQ FT)	SIGN AREA TYPE 2 (SQ FT)	4" X 6" WOOD SIGN SUPPORT (FOOT)	RELOCATE SIGN PANEL ASSEMBLY TYPE B**** (EACH)	SIGN PLACEMENT	
							HEIGHT ABOVE EDGE OF PAVEMENT	CENTERLINE OFFSET
U.S. ROUTE 150								
409+57 LT	A	W14-3-364848	5.60		12.0		6'-0"	31'
415+75 RT	B	W2-2-3030	6.25		15.0		6'-0"	31'
415+75 RT	B	W16-8-2412	2.00				5'-0"	31'
416+00 LT	C	W2-2-3030	6.25		15.0		6'-0"	32'
416+00 LT	C	W16-8-2412	2.00				5'-0"	32'
418+00 LT	D	M4-5-2412	2.00		12.0		9'-3"	32'
418+00 LT	D	M1-1-36	9.00				6'-3"	32'
418+00 LT	D	M6-1-2115	2.19				5'-0"	32'
418+05 RT	V	W14-1-3030	6.25		16.5		6'-0"	200'
420+00 RT	E	R2-1-2430	5.00		14.0		6'-0"	31'
420+50 RT	W	R11-1100-4830		10.00	13.5		6'-0"	31'
421+00 LT	E	R2-1-2430	5.00		14.5		6'-0"	31'
426+04 RT	A	W14-3-364848	5.60		16.5		6'-0"	28'
431+00 RT	F	W2-2-3030	6.25		16.0		6'-0"	28'
431+00 RT	F	W16-8-2412	2.00				5'-0"	28'
431+50 LT	G	W2-2-3030	6.25		16.5		6'-0"	40'
431+50 LT	G	W16-8-2412	2.00				5'-0"	40'
435+00 RT	H	W1-2-3030	6.25		15.0		6'-0"	28'
436+07 LT	A	W14-3-364848	5.60		17.5		6'-0"	31'
439+00 RT	I	M3-2-2412	2.00		15.5		8'-0"	44'
439+00 RT	I	M1-4-3024	5.00				6'-0"	44'
442+18 RT	J	R1-1-3030	6.25		15.5		6'-0"	48'
443+00 LT		SEE BELOW*			37.0	1	6'-6"	32'
443+00 LT	E	R2-1-2430	5.00				4'-0"	32'
443+00 RT	K	R2-1-2430	5.00		17.5		6'-0"	32'
445+50 LT	L	W2-2-3030	6.25		17.5		6'-0"	39'
445+50 LT	L	W16-8-2412	2.00				5'-0"	39'
449+00 RT	M	S4-1105-3030	6.25		17.5		6'-0"	32'
454+00 LT	N	R2-5-2430	5.00		16.5		6'-6"	40'
454+00 LT	N	R2-1101-1818	2.25				5'-0"	40'
454+02 RT	A	W14-3-364848	5.60		17.0		6'-0"	42'
456+00 LT	O	W1-2-3030	6.25		17.0		6'-0"	38'
469+00 RT	O	W1-2-3030	6.25		17.0		6'-0"	42'
488+00 LT	H	W1-2-3030	6.25		18.5		6'-0"	32'
496+79 LT	A	W14-3-364848	5.60		15.0		6'-0"	32'
499+00 RT	O	W1-2-3030	6.25		15.5		6'-0"	36'
516+00 LT	H	W1-2-3030	6.25		17.5		6'-0"	32'
517+91 RT	A	W14-3-364848	5.60		16.5		6'-0"	34'
519+00 LT	H	W1-2-3030	6.25		17.0		6'-0"	34'
540+00 LT	O	W1-2-3030	6.25		16.5		6'-0"	36'
565+43 LT	A	W14-3-364848	5.60		15.5		6'-0"	32'
583+91 RT	A	W14-3-364848	5.60		18.0		6'-0"	32'
597+11 LT	A	W14-3-364848	5.60		17.0		6'-0"	36'
616+59 RT	A	W14-3-364848	5.60		16.5		6'-0"	32'
682+12 LT	A	W14-3-364848	5.60		17.0		6'-0"	38'
700+07 LT	A	W14-3-364848	5.60		16.0		6'-0"	36'
700+07 RT	A	W14-3-364848	5.60		16.0		6'-0"	36'
702+00 RT	O	W1-2-3030	6.25		17.0		6'-0"	40'
722+00 LT	H	W1-2-3030	6.25		16.0		6'-0"	38'
723+83 RT	A	W14-3-364848	5.60		17.5		6'-0"	30'
729+11 LT	A	W14-3-364848	5.60		16.0		6'-0"	36'
732+00 RT	P	W1-2-3030	6.25		16.5		6'-6"	38'
732+00 RT	P	R2-1101-1818	2.25				5'-0"	38'
735+00 LT	M	S4-1105-3030	6.25		15.5		6'-0"	40'
741+00 RT	Q	W11-10-3030	6.25		18.5		6'-0"	32'
747+50 RT	R	R2-5-2430	5.00		16.5		6'-6"	38'
747+50 RT	R	R2-1101-1818	2.25				5'-0"	38'
749+17 RT	A	W14-3-364848	5.60		15.0		6'-0"	34'
751+00 LT	S	W1-2-3030	6.25		17.0		6'-6"	32'
751+00 LT	S	R2-1101-1818	2.25				5'-0"	32'
753+00 LT		SEE BELOW**			33.0	1	6'-6"	36'
753+00 LT	K	R2-1-2430	5.00				4'-0"	36'
753+00 RT		SEE BELOW***			32.0	1	6'-6"	36'
753+00 RT	T	R2-1-2430	5.00				4'-0"	36'
SUBTOTAL - U.S. ROUTE 150			306.29	10.00	845.0	3		

LOCATION	SEE DETAIL	STANDARD NUMBER	SIGN AREA TYPE 1 (SQ FT)	SIGN AREA TYPE 2 (SQ FT)	4" X 6" WOOD SIGN SUPPORT (FOOT)	RELOCATE SIGN PANEL ASSEMBLY TYPE B**** (EACH)	SIGN PLACEMENT	
							HEIGHT ABOVE EDGE OF PAVEMENT	CENTERLINE OFFSET
SEMINARY STREET								
1100+70 RT	J	R1-1-3030	6.25		16.5		6'-0"	30'
C.H. 36 NORTH								
1203+60 LT	J	R1-1-3030	6.25		16.5		6'-0"	28'
1208+50 LT	U	W3-1A-3636	9.00		16.0		6'-0"	36'
T.R. 2075								
1305+90 RT	J	R1-1-3030	6.25		16.5		6'-0"	23'
C.H. 36 SOUTH								
1502+10 RT	J	R1-1-3030	6.25		16.5		6'-0"	36'
T.R. 2200								
1602+20 RT	J	R1-1-3030	6.25		16.5		6'-0"	34'
T.R. 2325								
1700+85 LT	J	R1-1-3030	6.25		16.5		6'-0"	31'
T.R. 2375								
1801+70 RT	J	R1-1-3030	6.25		16.5		6'-0"	29'
T.R. 2400								
1900+70 LT	J	R1-1-3030	6.25		16.5		6'-0"	30'
T.R. 2450								
2401+55 RT	J	R1-1-3030	6.25		16.5		6'-0"	29'
SUBTOTAL - SIDE ROADS			65.25	0.00	164.5	0		
TOTAL			371.54	10.00	1009.5	3		

* DOWNS POPULATION SIGN
 ** DOWNS / BLOOMINGTON MILEAGE SIGN
 *** LEROY POPULATION SIGN
 **** RELOCATED SIGNS REQUIRE TWO POSTS - INSTALL SPEED LIMIT SIGN ON POST FURTHEST FROM ROADWAY

ILLINOIS DEPARTMENT OF TRANSPORTATION
 F.A.S. 1517 (U.S. ROUTE 150)
SIGN SCHEDULE
 (SHEET 1 OF 2)
 SCALE: VERT. DATE
 HORIZ. DATE
 DRAWN BY
 CHECKED BY

COMPANY NAME: #COMPANY NAME#
 PROJECT CONTACT: #PROJECT CONTACT#
 CLIENT: #CLIENT#
 #DATE#
 #FILE#

F.A.S. RTE.	SECTION	COUNTY	TOTAL SHEETS	SHEET NO.
1517	2)RS-3 (3)RS-4	MCLEAN	223	34
STA.		TO STA.		
FED. ROAD DIST. NO.	ILLINOIS	FED. AID PROJECT		

66383

EXISTING SIGNS TO BE RELOCATED OR REMAIN IN PLACE			
EXISTING STA. / OFFSET	PROPOSED STA. / OFFSET	SIGN INFORMATION	RELOCATE GROUND MOUNTED SIGN SUPPORT (EACH)
SEMINARY STREET			
1100+45, 26' LT	N/A*	MCLEAN COUNTY 27	
1100+90, 36' RT	1100+50, 21' RT	END MCLEAN COUNTY 27	1
1100+96, 50' LT	N/A*	2050 E	
C.H. 36 (NORTH)			
420+94, 44' LT	424+10, 36' LT	800 N - U.S. 150	1
1204+82, 170' LT	1204+00, 32' RT	DO NOT PASS	1
1205+17, 130' LT	1204+75, 30' RT	WEIGHT LIMIT	1
1205+87, 65' LT	1210+00, 29' RT	PASS WITH CARE	1
1205+91, 119' LT	1207+00, 30' LT	MCLEAN COUNTY 36	1
1206+43, 28' LT	1206+50, 30' RT	MCLEAN COUNTY 36	1
T.R. 2075			
1304+05, 40' RT	1306+00, 23' LT	2075 E - 800 N	1
C.H. 36 (SOUTH)			
1502+00, 15' LT	1501+00, 22' LT	MCLEAN COUNTY 36	1
1502+09, 39' RT	1501+00, 30' RT	MCLEAN COUNTY 36 <-	1
T.R. 2200			
1602+80, 78' LT	1601+00, 21' LT	WEIGHT LIMIT	1
T.R. 2325			
1701+21, 15' RT	1701+50, 21' RT	WEIGHT LIMIT	1
T.R. 2375			
1801+74, 19' LT	1801+50, 21' LT	WEIGHT LIMIT	1
T.R. 2400			
1900+31, 24' RT	1900+30, 27' RT	2400 E - 560 N	1
1901+46, 18' RT	1901+50, 20' RT	WEIGHT LIMIT	1
T.R. 2450			
2401+32, 13' LT	2401+50, 21' LT	DEAD END	1
TOTAL			16

* EXISTING SIGN TO REMAIN IN CURRENT LOCATION.

PLAN	BY	DATE
NO.		
NO.		
NO.		
NO.		

PROFILE	BY	DATE
NO.		
NO.		
NO.		
NO.		

COMPANY NAME: #COMPANY_NAME#
PROJECT CONTACT: #PROJECT_CONTACT#
CLIENT: #CLIENT#
#DATES# #TIME#

ILLINOIS DEPARTMENT OF TRANSPORTATION
F.A.S. 1517 (U.S. ROUTE 150)
SIGN SCHEDULE
(SHEET 2 OF 2)

SCALE: VERT. _____
HORIZ. _____

DATE _____ DRAWN BY _____
CHECKED BY _____

F.A.S. RTE.	SECTION	COUNTY	TOTAL SHEETS	SHEET NO.
1517	(2)RS-3 (3)RS-4	MCLEAN	223	35
STA. _____ TO STA. _____				
FED. ROAD DIST. NO. _____ ILLINOIS FED. AID PROJECT				

66383

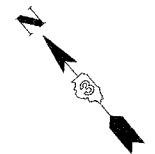
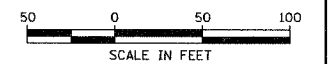

PLAN	DATE
BY	
REVISIONS	
NO.	
DATE	
BY	
REVISIONS	
NO.	
DATE	
BY	

PROFILE	DATE
BY	
REVISIONS	
NO.	
DATE	
BY	
REVISIONS	
NO.	
DATE	
BY	

COMPANY NAME: #COMPANY NAME#
 PROJECT CONTACT: #PROJECT CONTACT#
 CLIENT: #CLIENT#
 DATE: #DATE#
 BY: #BY#

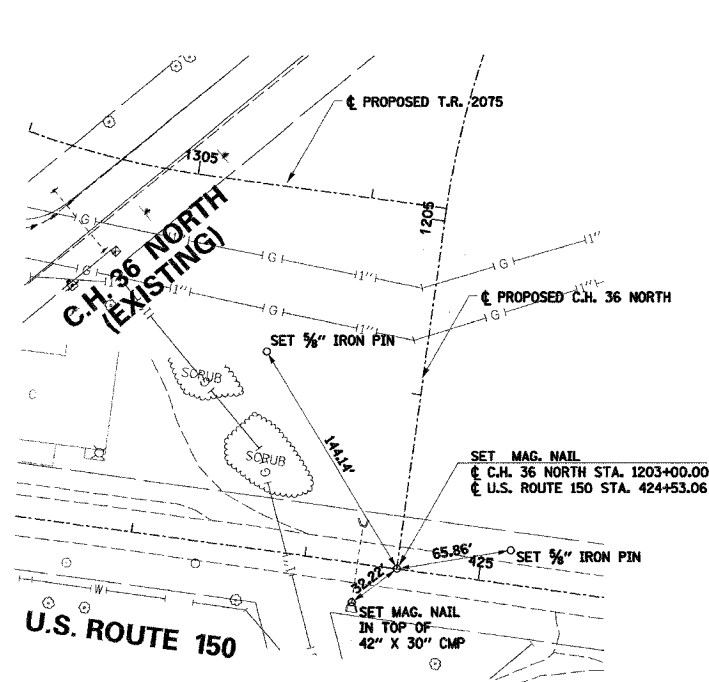

PROPOSED CENTERLINE INTERSECTION
 C.H. 36 NORTH STA. 1203+00.00 =
 U.S. ROUTE 150 STA. 424+53.06

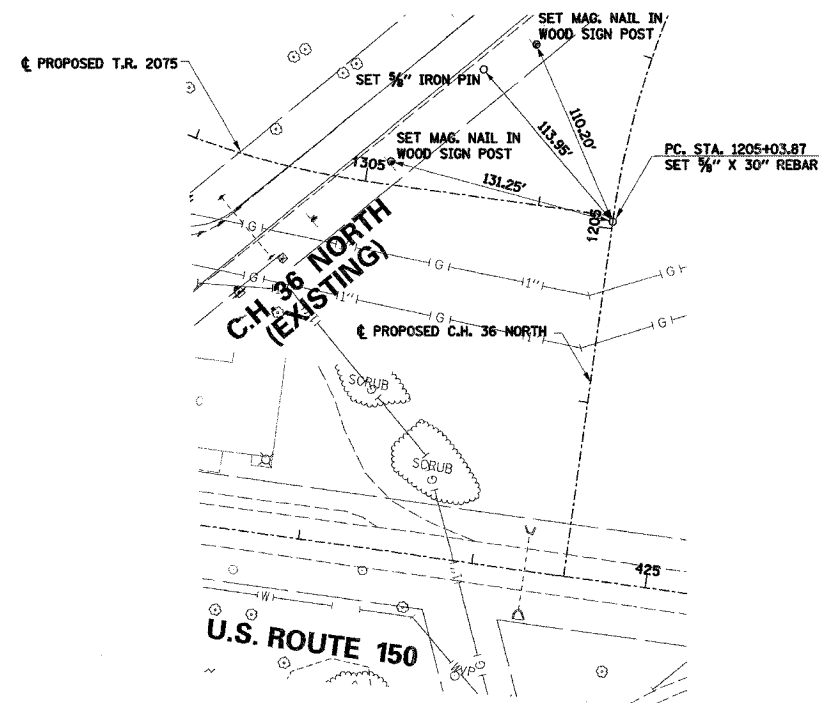

PROPOSED CENTERLINE
 C.H. 36 NORTH PC STA. 1205+03.87

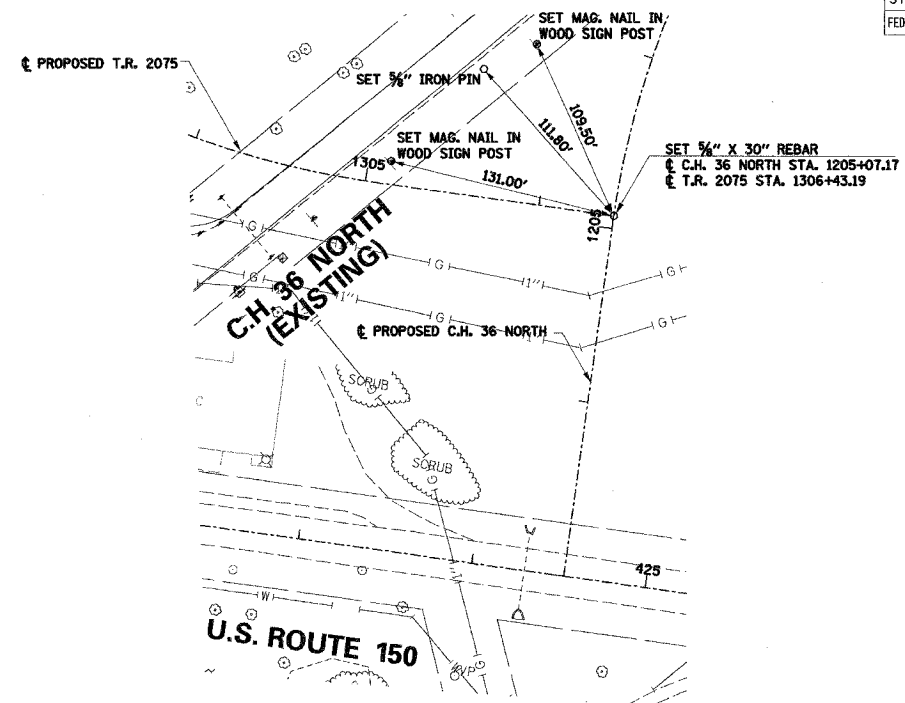

PROPOSED CENTERLINE INTERSECTION
 C.H. 36 NORTH STA. 1205+07.17 =
 T.R. 2075 STA. 1306+43.19

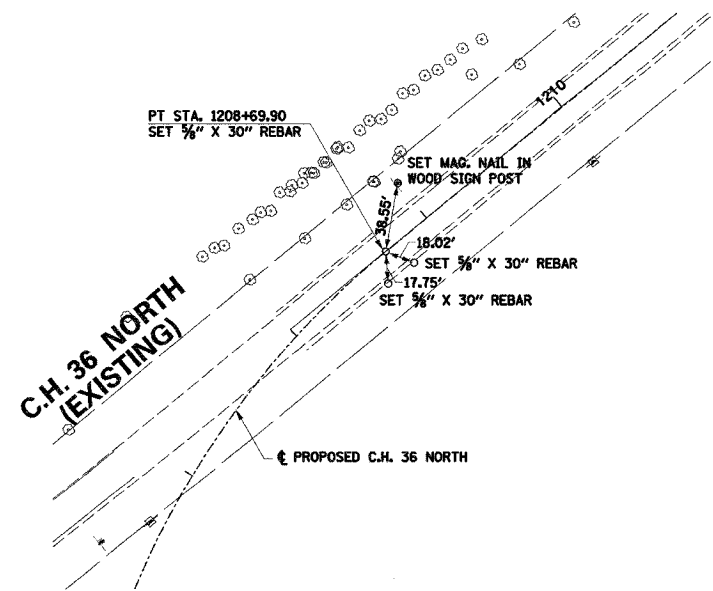

PROPOSED CENTERLINE
 C.H. 36 PT STA. 1208+69.90

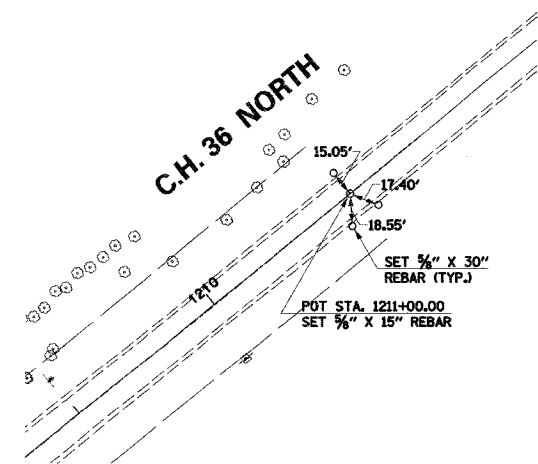

PROPOSED CENTERLINE
 T.R. 2075 POT STA. 1211+00.00

ILLINOIS DEPARTMENT OF TRANSPORTATION
 F.A.S. 1517 (U.S. ROUTE 150)

**TIE POINTS
 (C.H. 36 NORTH)**

SCALE: VERT. _____
 HORIZ. _____
 DATE _____

DRAWN BY _____
 CHECKED BY _____

F.A.S. RTE.	SECTION	COUNTY	TOTAL SHEETS	SHEET NO.
1517	2)RS-3 (3)RS-4	MCLEAN	223	36
STA. _____ TO STA. _____		ILLINOIS FED. AID PROJECT		

66383

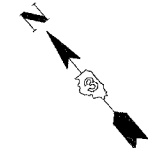
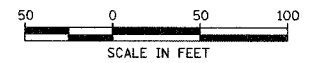

DATE	
BY	
SURVEYED	
ALIGNED	
CHECKED	
PLANNED	
FILED	
NO.	

DATE	
BY	
SURVEYED	
GRADES	
CHECKED	
NOTED	
PLANNED	
FILED	
NO.	

COMPANY NAME # COMPANY NAME #
 PROJECT CONTACT # PROJECT CONTACT #
 CLIENT # CLIENT #
 DATE # TIME #
 SHEET #

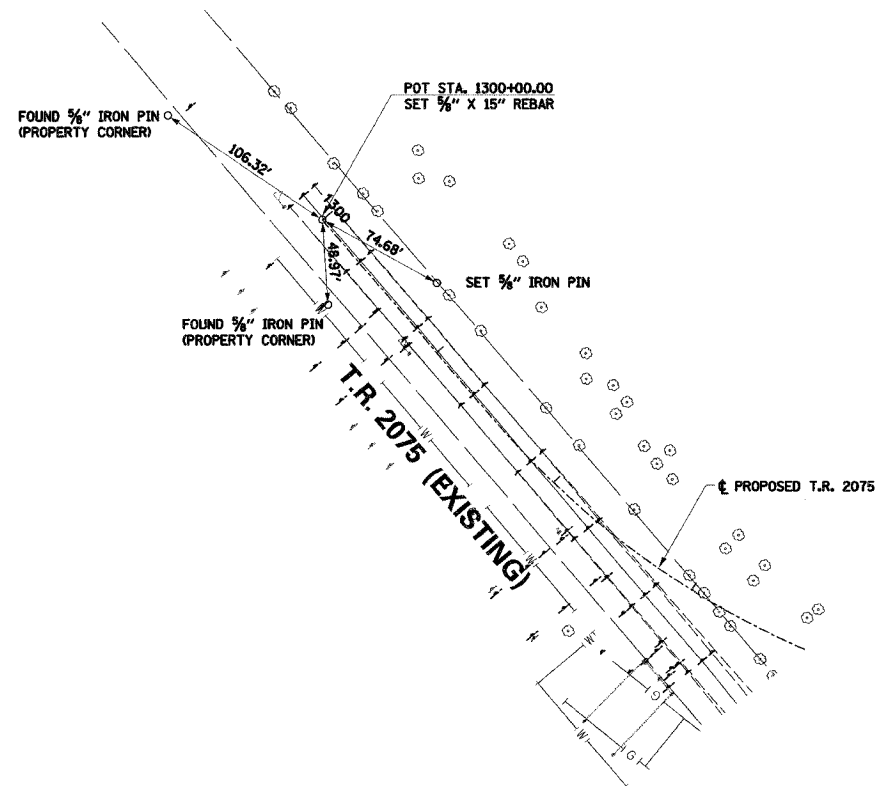

PROPOSED CENTERLINE
T.R. 2075 POT STA. 1300+00.00

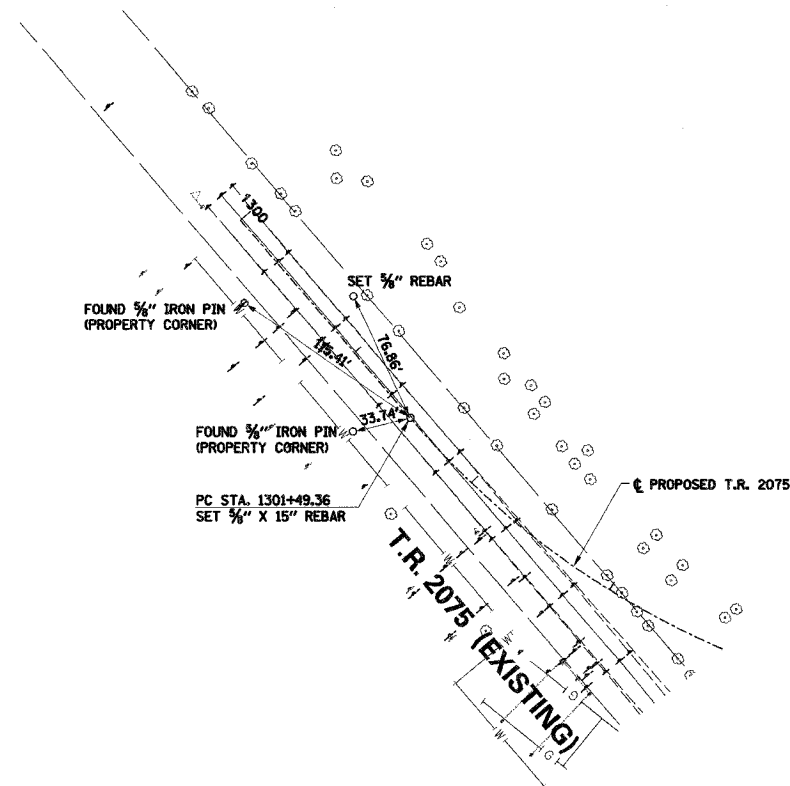

PROPOSED CENTERLINE
T.R. 2075 PC STA. 1301+49.36

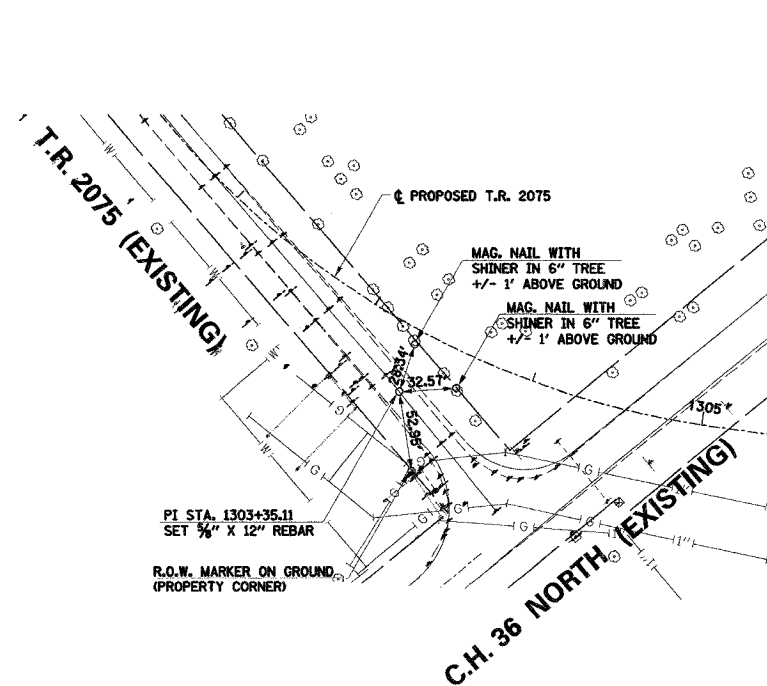

PROPOSED CENTERLINE
T.R. 2075 PI STA. 1303+35.11

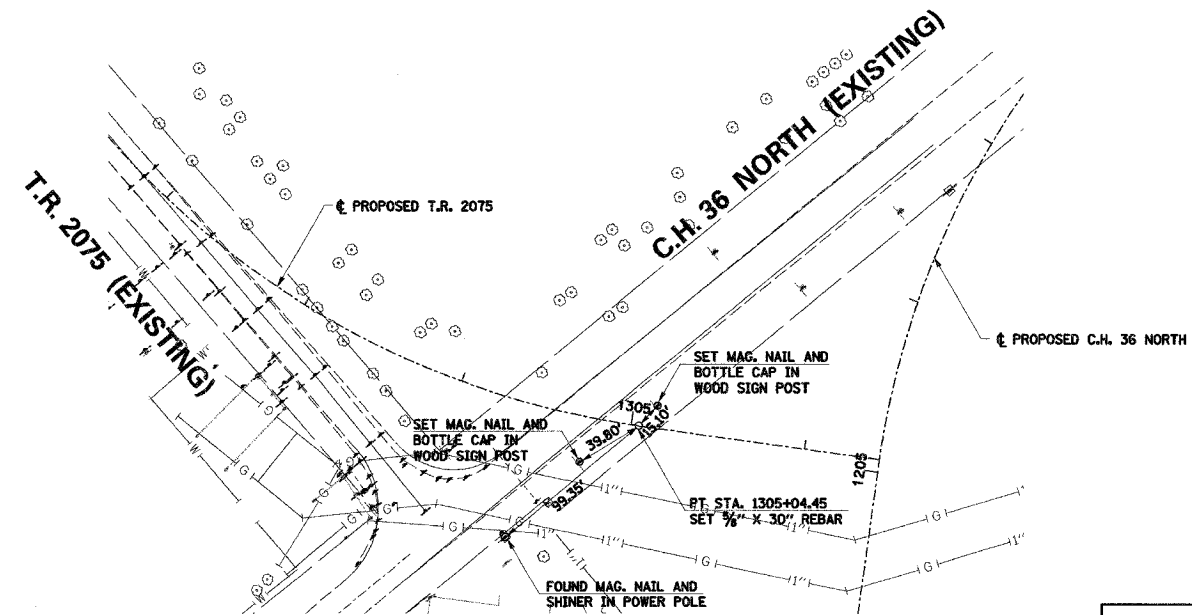

PROPOSED CENTERLINE
T.R. 2075 PT STA. 1305+04.45

ILLINOIS DEPARTMENT OF TRANSPORTATION
F.A.S. 1517 (U.S. ROUTE 150)

TIE POINTS
(T.R. 2075)

SCALE: VERT.
HORIZ.
DATE

DRAWN BY
CHECKED BY

F.A.S. RTE.	SECTION	COUNTY	TOTAL SHEETS	SHEET NO.
1517 (2)RS-3 (3)RS-4		MCLEAN	223	37
STA. _____ TO STA. _____		ILLINOIS FED. AID PROJECT		

66383

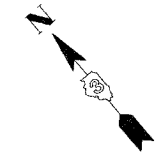
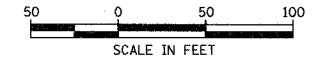

DATE	BY

DATE	BY

COMPANY NAME: #COMPANY NAME#
 PROJECT CONTACT: #PROJECT_CONTACT#
 CLIENT: #CLIENT#
 #DATE# #TIME#
 #FILE#

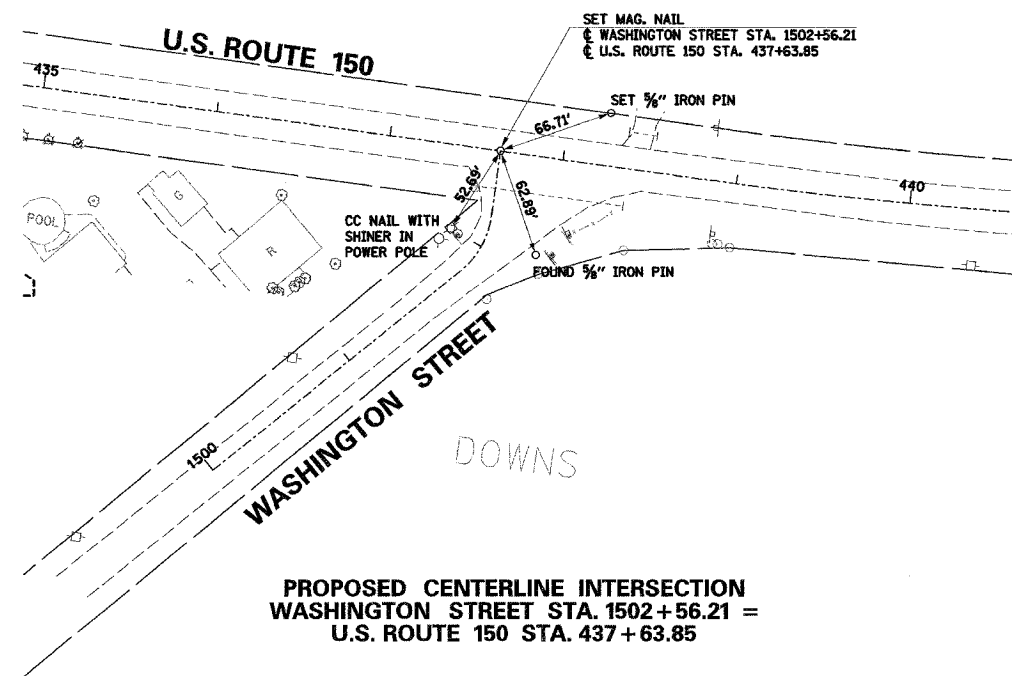

PROPOSED CENTERLINE INTERSECTION
 WASHINGTON STREET STA. 1502+56.21 =
 U.S. ROUTE 150 STA. 437+63.85

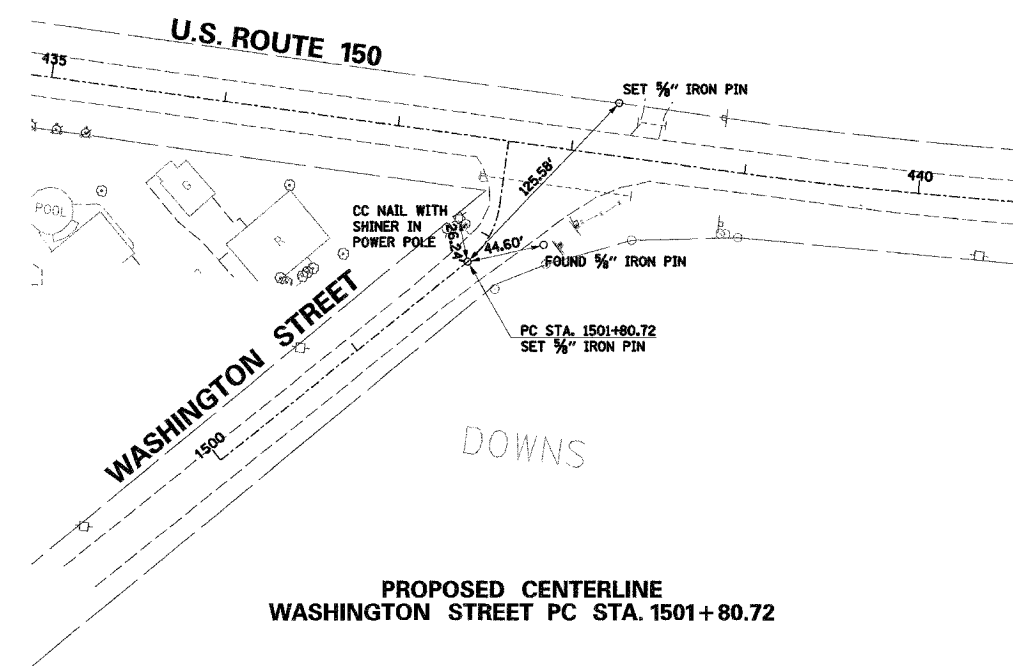

PROPOSED CENTERLINE
 WASHINGTON STREET PC STA. 1501+80.72

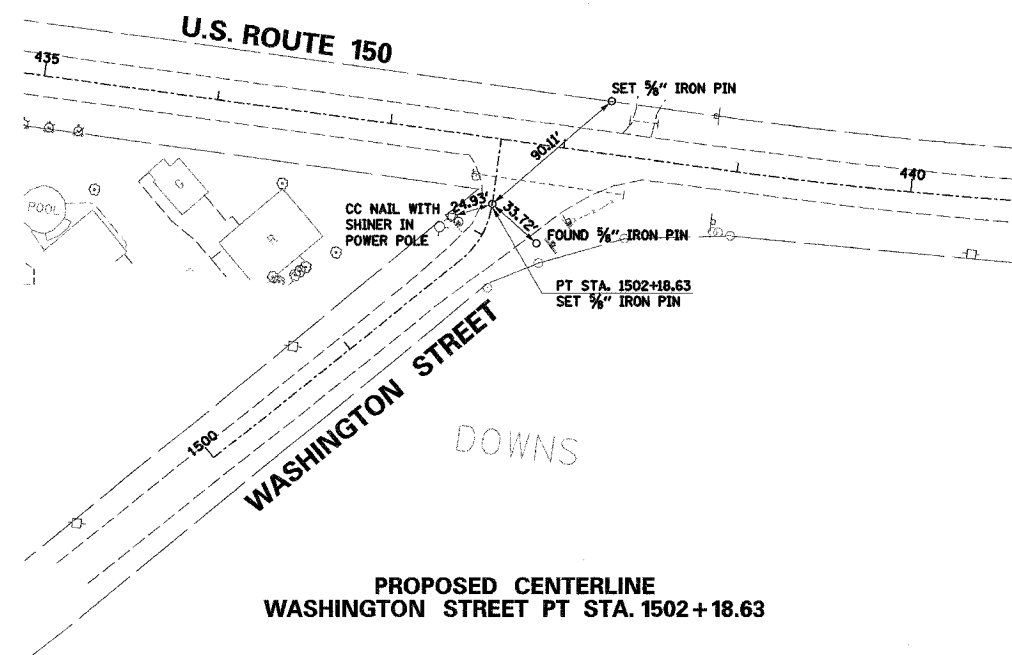

PROPOSED CENTERLINE
 WASHINGTON STREET PT STA. 1502+18.63

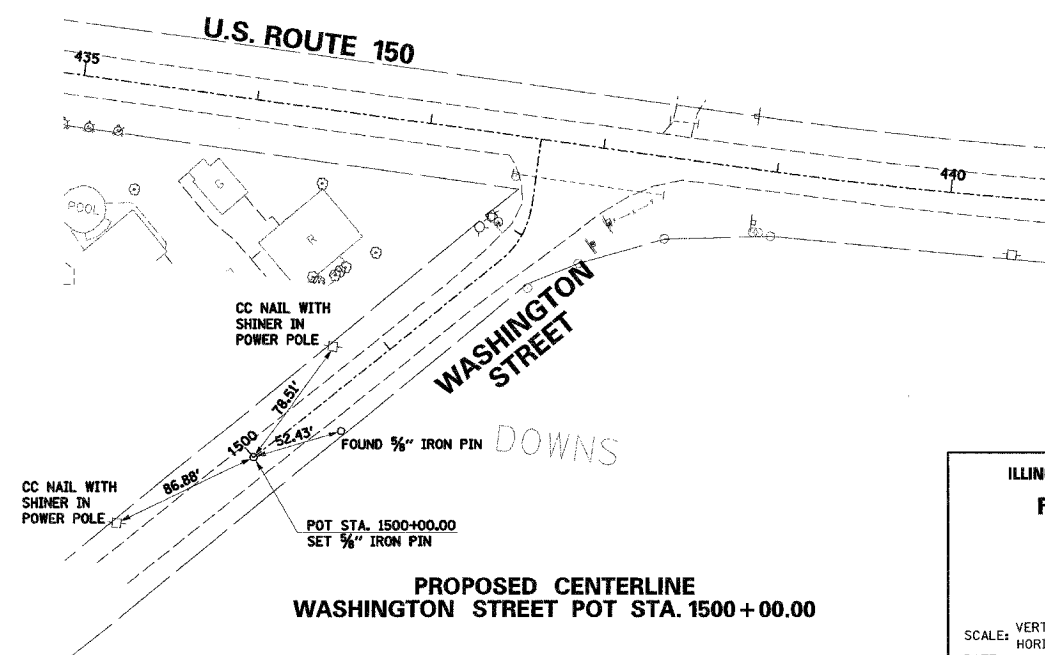

PROPOSED CENTERLINE
 WASHINGTON STREET POT STA. 1500+00.00

ILLINOIS DEPARTMENT OF TRANSPORTATION
 F.A.S. 1517 (U.S. ROUTE 150)
TIE POINTS
 (WASHINGTON STREET)
 SCALE: VERT. _____
 HORIZ. _____
 DATE _____ DRAWN BY _____
 CHECKED BY _____

F.A.S. RTE.	SECTION	COUNTY	TOTAL SHEETS	SHEET NO.
1517 (2)RS-3 (3)RS-4		MCLEAN	223	38
STA. _____		TO STA. _____		
FED. ROAD DIST. NO. - ILLINOIS FED. AID PROJECT				

66383

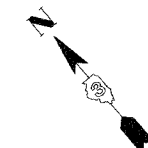
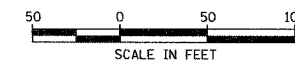

PLAN	DATE
SURVEYED _____	_____
ALIGNED _____	_____
CHECKED _____	_____
BY _____	_____
NO. _____	_____

PROFILE	DATE
SURVEYED _____	_____
GRADES CHECKED _____	_____
BY _____	_____
NO. _____	_____

COMPANY NAME: #COMPANY NAME#
PROJECT CONTACT: #PROJECT CONTACT#
CLIENT: #CLIENT#
#DATE# #TIME#
#FILE#

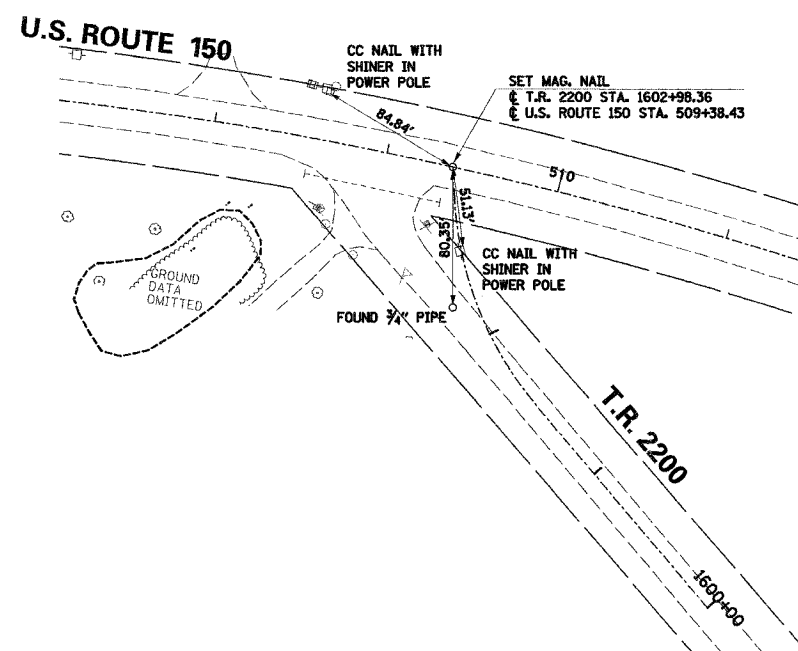

PROPOSED CENTERLINE INTERSECTION
T.R. 2200 STA. 1602+98.36 =
U.S. ROUTE 150 STA. 509+38.43

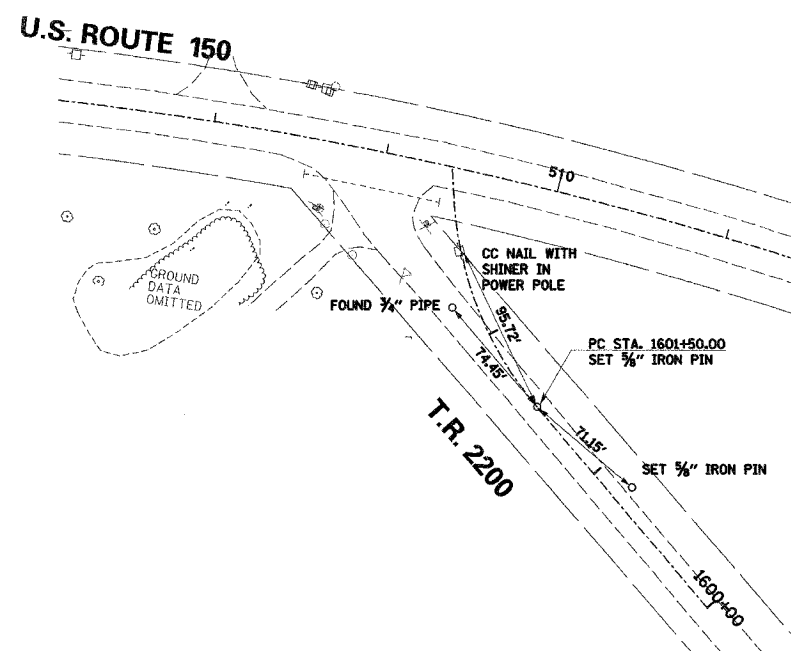

PROPOSED CENTERLINE
T.R. 2200 PC STA. 1601+50.00

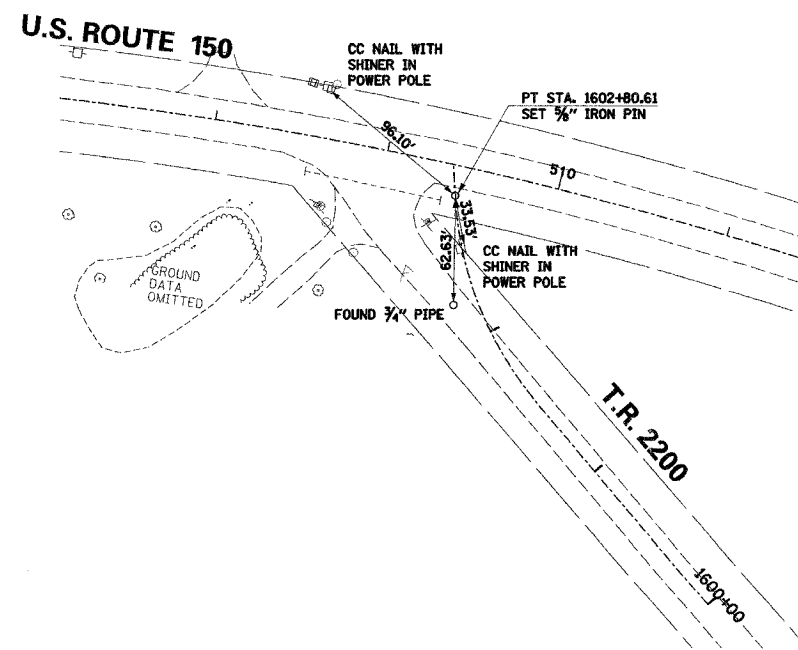

PROPOSED CENTERLINE
T.R. 2200 PT STA. 1602+80.61

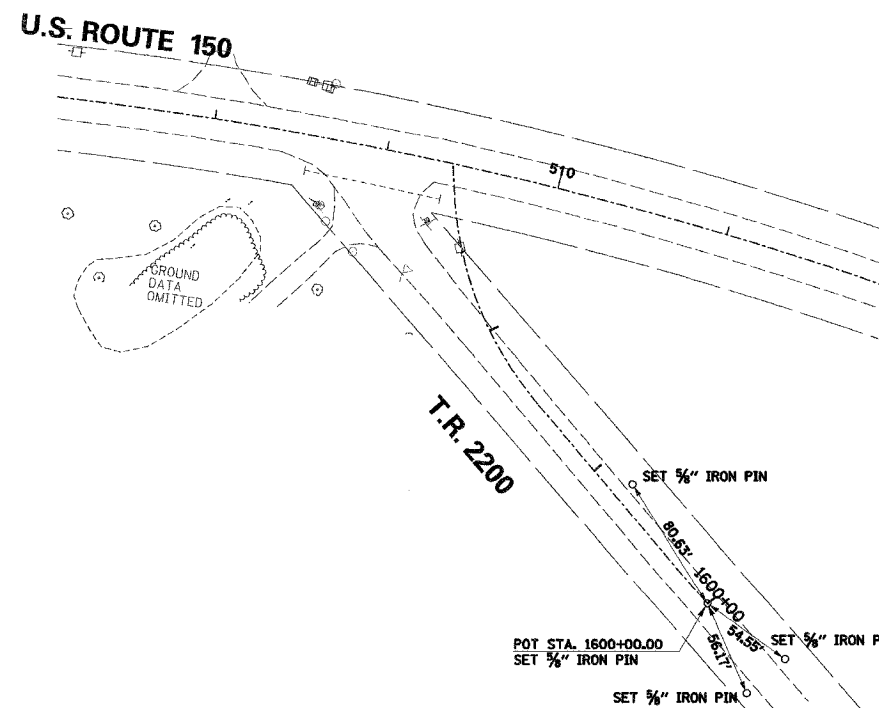

PROPOSED CENTERLINE
T.R. 2200 POT STA. 1600+00.00

ILLINOIS DEPARTMENT OF TRANSPORTATION
F.A.S. 1517 (U.S. ROUTE 150)

TIE POINTS
(T.R. 2200)

SCALE: VERT. _____
HORIZ. _____
DATE _____

DRAWN BY _____
CHECKED BY _____

GENERAL NOTES (CONSTRUCTION STAGING)

F.A.S. RTE.	SECTION	COUNTY	TOTAL SHEETS	SHEET NO.
1517 (2)RS-3 (3)RS-4		MCLEAN	223	39
STA.	TO STA.			
FED. ROAD DIST. NO.	ILLINOIS FED. AID PROJECT			

66383

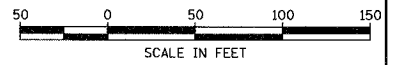

LEGEND (CONSTRUCTION STAGING)

- STAGE 1 CONSTRUCTION
- STAGE 2 CONSTRUCTION
- STAGE 2 REMOVAL
- STAGE 3 CONSTRUCTION
- STAGE 3 REMOVAL

DETOUR SIGNAGE (SEE BELOW)

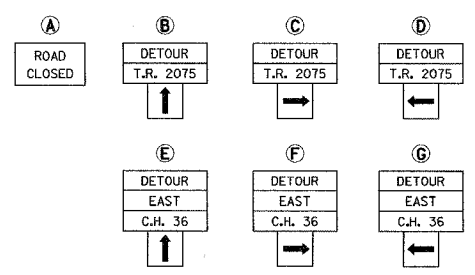

- ROAD CLOSED 48" X 30" WHITE
- DETOUR 24" X 12" ORANGE
- C.H. 36 OR T.R. 2075 24" X 12" ORANGE
- DETOUR 24" X 12" ORANGE
- ALL ARROWS - 21" X 15" ORANGE

- STAGE 1:**
- CONSTRUCT RELOCATED SECTION OF C.H. 36.
 - ALL LANES OF U.S. ROUTE 150 AND C.H. 36 SHALL REMAIN OPEN TO TRAFFIC AT ALL TIMES.
 - NO SURFACE COURSE SHALL BE PLACED DURING STAGE 1 OPERATIONS.
- STAGE 2:**
- CONSTRUCT CONNECTION BETWEEN RELOCATED C.H. 36 AND EXISTING C.H. 36. WORK SHALL BE COMPLETED UNDER TRAFFIC WITH AT LEAST ONE LANE OPEN TO TRAFFIC AT ALL TIMES AND BOTH LANES OPEN AT NIGHT. BOTH LANES SHALL BE BUILT-UP AT THE SAME TIME WITH A MAXIMUM LANE DIFFERENTIAL OF 2" UNLESS APPROVED IN WRITING BY THE ENGINEER. TEMPORARY RAMPS SHALL BE CONSTRUCTED AS NEEDED TO TRANSITION BACK TO EXISTING OR RELOCATED C.H. 36. A BUMP SIGN SHALL BE PLACED 100' IN ADVANCE OF THE RAMPS IN EITHER DIRECTION. TRAFFIC SHALL BE SHIFTED PERMANENTLY ONTO THE NEW ALIGNMENT AS DIRECTED BY THE ENGINEER.
 - REQUIRED DETOUR SIGNAGE SHALL BE INSTALLED IMMEDIATELY AFTER TRAFFIC HAS BEEN SHIFTED ONTO THE NEW ALIGNMENT. EXACT SIGN LOCATIONS SHALL BE DETERMINED BY THE ENGINEER.
 - REMOVAL OF EXISTING C.H. 36 PAVEMENT MAY TAKE PLACE ONLY AFTER TRAFFIC HAS BEEN SHIFTED ONTO THE NEW ALIGNMENT AND DETOUR SIGNAGE HAS BEEN INSTALLED.
 - CONSTRUCT RELOCATED SECTION OF T.R. 2075.
 - NO SURFACE COURSE SHALL BE PLACED DURING STAGE 2 OPERATIONS.
- STAGE 3:**
- CONSTRUCT CONNECTION BETWEEN RELOCATED T.R. 2075 AND EXISTING T.R. 2075. WORK SHALL BE COMPLETED UNDER TRAFFIC WITH AT LEAST ONE LANE OPEN TO TRAFFIC AT ALL TIMES AND BOTH LANES OPEN AT NIGHT. BOTH LANES AND BITUMINOUS SHOULDERS SHALL BE BUILT-UP AT THE SAME TIME WITH A MAXIMUM LANE DIFFERENTIAL OF 2" UNLESS APPROVED IN WRITING BY THE ENGINEER. TEMPORARY RAMPS SHALL BE CONSTRUCTED AS NEEDED TO TRANSITION BACK TO EXISTING OR RELOCATED T.R. 2075. A BUMP SIGN SHALL BE PLACED 100' IN ADVANCE OF THE RAMPS IN EITHER DIRECTION. TRAFFIC SHALL BE SHIFTED PERMANENTLY ONTO THE NEW ALIGNMENT AS DIRECTED BY THE ENGINEER.
 - DETOUR SIGNAGE SHALL BE REMOVED IMMEDIATELY AFTER TRAFFIC HAS BEEN SHIFTED PERMANENTLY ONTO THE NEW ALIGNMENT.
 - REMOVAL OF THE EXISTING T.R. 2075 PAVEMENT MAY TAKE PLACE ONLY AFTER TRAFFIC HAS BEEN SHIFTED PERMANENTLY ONTO THE NEW ALIGNMENT AND DETOUR SIGNAGE HAS BEEN REMOVED.
 - ACCESS TO RESIDENTIAL AND COMMERCIAL ENTRANCES SHALL BE MAINTAINED AT ALL TIMES.
 - NO SURFACE COURSE SHALL BE PLACED DURING STAGE 3 OPERATIONS.
- STAGE 4:**
- PLACE SURFACE COURSE ON C.H. 36.
 - PLACE SURFACE COURSE ON T.R. 2075.
 - STAGE 4 SHALL TAKE PLACE ONLY AFTER SURFACE COURSE HAS BEEN PLACED ON ADJACENT SECTION OF U.S. ROUTE 150.

DATE	BY	REVISION

DATE	BY	REVISION

COMPANY NAME	#COMPANY NAME
PROJECT CONTACT	#PROJECT CONTACT
CLIENT	#CLIENT
DATE	#DATE
FILE#	#FILE#

MATCHLINE STA. 415+00

MATCHLINE STA. 430+00

ILLINOIS DEPARTMENT OF TRANSPORTATION
F.A.S. 1517 (U.S. ROUTE 150)
CONSTRUCTION STAGING /
MAINTENANCE OF TRAFFIC PLAN
(C.H. 36 NORTH /T.R. 2075 RELOCATION)

SCALE: VERT. _____
 HORIZ. _____
 DATE _____

DRAWN BY _____
 CHECKED BY _____

STONE DUMPED RIPRAP (SEE DETAIL):
 1. AREA SHALL BE GRADED TO THE SATISFACTION OF THE ENGINEER.
 2. FINAL RIPRAP PLACEMENT SUBJECT TO THE APPROVAL OF THE ENGINEER.

DAVID A. FOGEL

PI STA. = 411+09.09
 $\Delta = 13^\circ 07' 32''$ (LT)
 $D = 1^\circ 59' 37''$
 $R = 2,873.87'$
 $T = 330.63'$
 $L = 658.36'$
 $E = 18.96'$
 $\theta = 0^\circ$
 $T.R. = 0'$
 $S.E. RUN = 0'$
 $P.C. STA. = 407+78.46$
 $P.T. STA. = 414+36.82$

F.A.S. RTE.	SECTION	COUNTY	TOTAL SHEETS	SHEET NO.
1517 (2)RS-3 (3)RS-4		MCLEAN	223	40
STA. _____ TO STA. _____				
FED. ROAD DIST. NO. _____ ILLINOIS FED. AID PROJECT				

66383

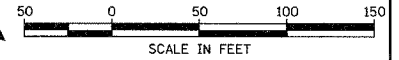

DATE	
BY	
REVISION	
NO.	
DATE	
BY	
REVISION	
NO.	
DATE	
BY	
REVISION	
NO.	

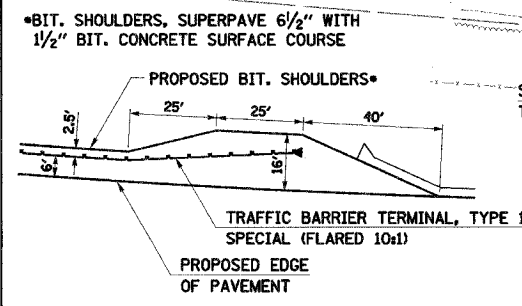
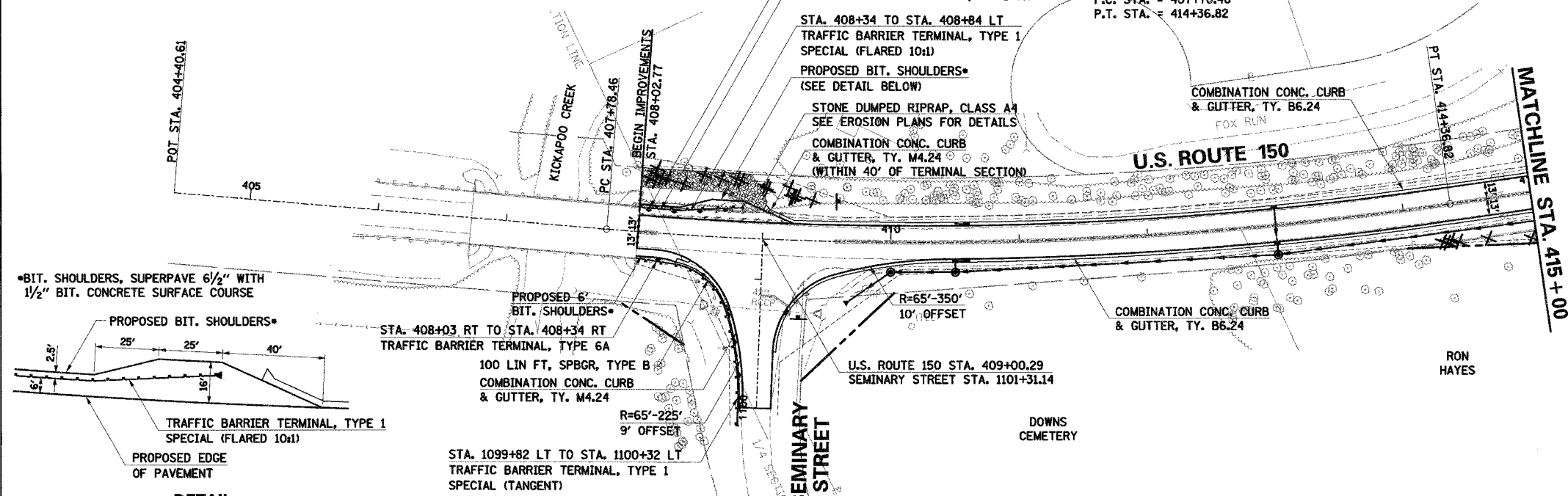

CLASS D PATCHES, 10 INCH:
 STA. 410+50.00 LT, 24.7 SQ YD (TYPE IID)
 STA. 410+50.00 RT, 24.7 SQ YD (TYPE IID)
 STA. 412+77.97 RT, 8.7 SQ YD (TYPE IID)
 STA. 413+00.00 LT, 24.5 SQ YD (TYPE IID)
 STA. 413+00.00 RT, 24.5 SQ YD (TYPE IID)
 STA. 413+30.77 RT, 8.7 SQ YD (TYPE IID)
 STA. 414+36.37 RT, 8.7 SQ YD (TYPE IID)

LEGEND

- EXISTING R.O.W.
- - - PROPOSED R.O.W.
- /// TEMPORARY EASEMENT
- FLOW ARROW
- - - CONSTRUCTION LIMITS
- ▨ PAVEMENT REMOVAL
- + TREE REMOVAL

NOTE:
 SEE DRAINAGE PLAN AND PROFILE SHEETS FOR STORM SEWER DETAILS.

DATE	
BY	
REVISION	
NO.	
DATE	
BY	
REVISION	
NO.	
DATE	
BY	
REVISION	
NO.	

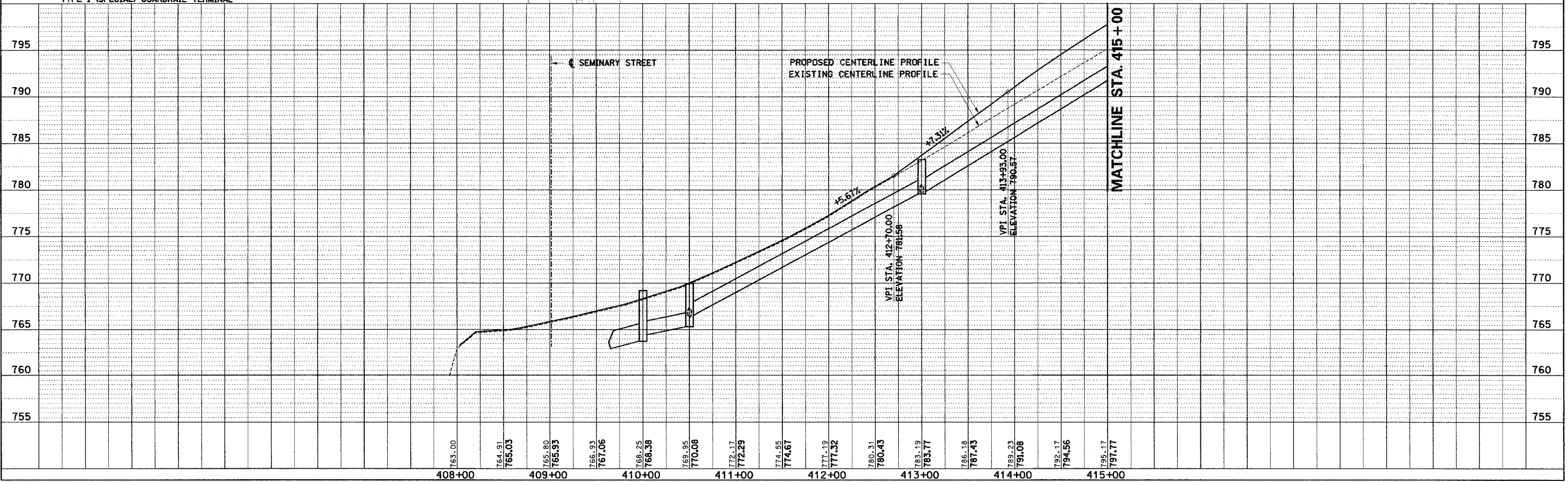

COMPANY NAME: #COMPANY NAME#
 PROJECT CONTACT: #PROJECT CONTACT#
 CLIENT: #CLIENT#
 DATE: #DATE#
 TIME: #TIME#
 FILE: #FILE#

U.S. ROUTE 150 STA. 408+02.77 TO STA. 415+00 - PLAN AND PROFILE

F.A.S. RT#	SECTION	COUNTY	TOTAL SHEETS	SHEET NO.
1517 (2)RS-3 (3)RS-4		MCLEAN	223	41
STA. _____ TO STA. _____				
FED. ROAD DIST. NO. _____ ILLINOIS FED. AID PROJECT				

66383

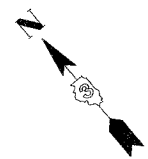
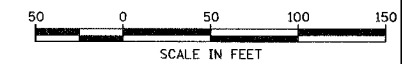

LEGEND

- EXISTING R.O.W.
- - - PROPOSED R.O.W.
- /// TEMPORARY EASEMENT
- FLOW ARROW
- - - CONSTRUCTION LIMITS
- ▨ PAVEMENT REMOVAL
- ⊕ TREE REMOVAL

DATE	BY	REVISION

DATE	BY	REVISION

COMPANY NAME: _____
 PROJECT CONTACT: _____
 CLIENT: _____
 DATE: _____

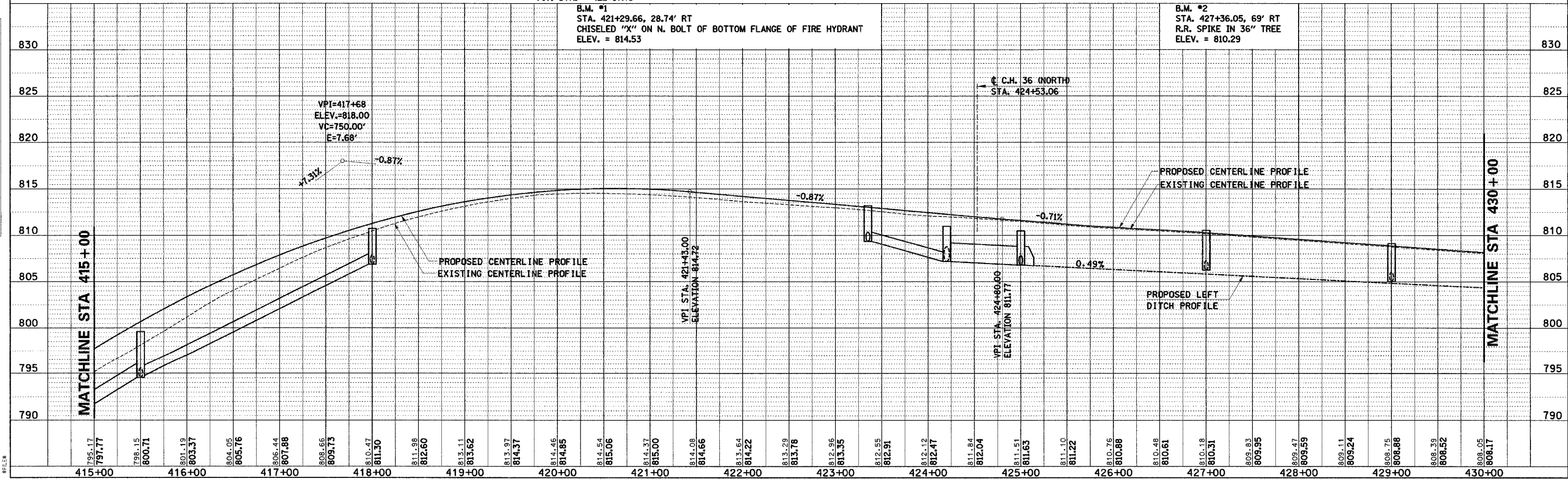
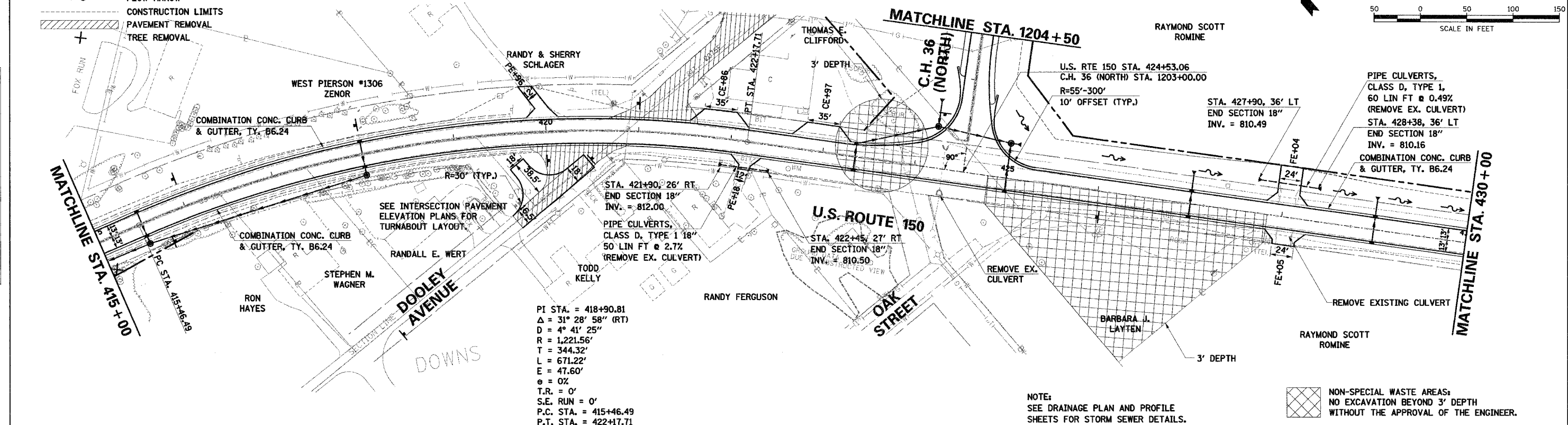

U.S. ROUTE 150 STA. 415+00 TO STA. 430+00 - PLAN AND PROFILE

F.A.S. RTE.	SECTION	COUNTY	TOTAL SHEETS	SHEET NO.
1517 (2)RS-3 (3)RS-4		MCLEAN	223	42
STA.	TO STA.			
FED. ROAD DIST. NO. - ILLINOIS FED. AID PROJECT				

66383

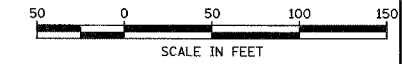

DATE	
BY	
REVISION	
NO.	
DATE	
BY	
REVISION	
NO.	
DATE	
BY	
REVISION	
NO.	

DATE	
BY	
REVISION	
NO.	
DATE	
BY	
REVISION	
NO.	
DATE	
BY	
REVISION	
NO.	

COMPANY NAME: #COMPANY NAME#
 PROJECT CONTACT: #PROJECT CONTACT#
 CLIENT: #CLIENT#
 DATE: #DATE#
 SHEET: #SHEET#

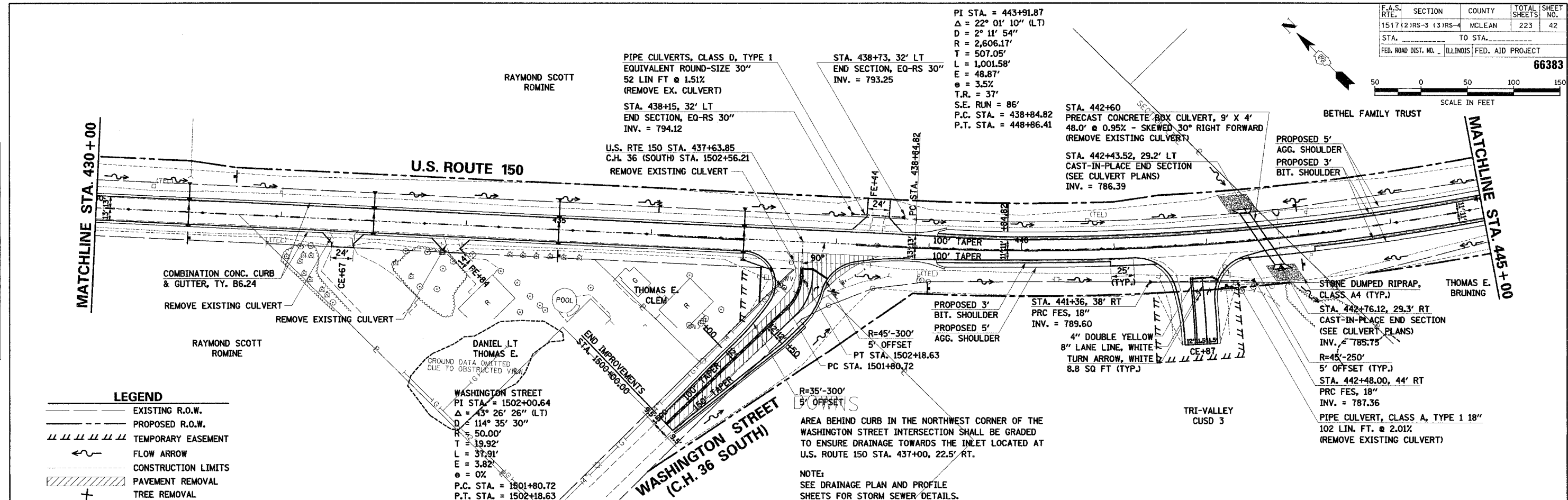

LEGEND

- EXISTING R.O.W.
- PROPOSED R.O.W.
- TEMPORARY EASEMENT
- FLOW ARROW
- CONSTRUCTION LIMITS
- PAVEMENT REMOVAL
- TREE REMOVAL

WASHINGTON STREET
 PI STA. = 1502+00.64
 $\Delta = 43^\circ 26' 26''$ (LT)
 $D = 114^\circ 35' 30''$
 $R = 50.00'$
 $T = 19.92'$
 $L = 37.91'$
 $E = 3.82'$
 $\theta = 0\%$
 P.C. STA. = 1501+80.72
 P.T. STA. = 1502+18.63

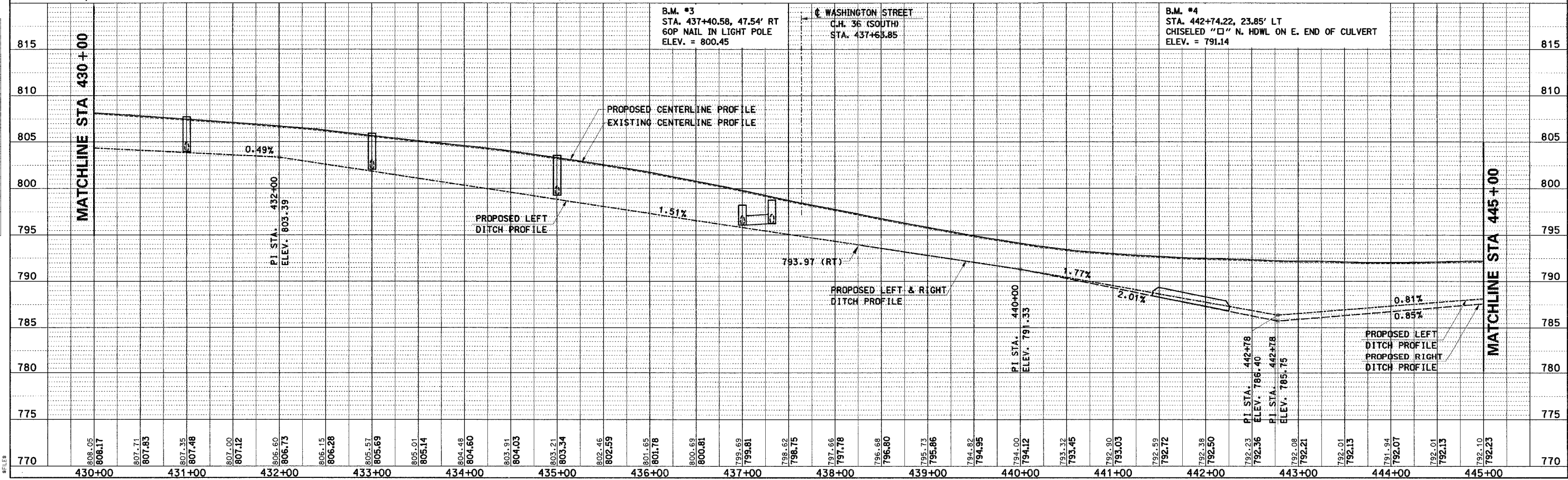

U.S. ROUTE 150 STA. 430+00 TO STA. 445+00 - PLAN AND PROFILE

F.A.S. RTE.	SECTION	COUNTY	TOTAL SHEETS	SHEET NO.
1517	2)RS-3 (3)RS-4	MCLEAN	223	43
STA.	TO STA.			
FED. ROAD DIST. NO.	ILLINOIS FED. AID PROJECT		66383	

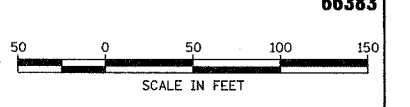

DATE	BY
DATE	BY
DATE	BY

DATE	BY
DATE	BY
DATE	BY

COMPANY NAME: #COMPANY NAME#
 PROJECT CONTACT: #PROJECT CONTACT#
 CLIENT: #CLIENT#
 DATE: #DATE#
 BY: #BY#

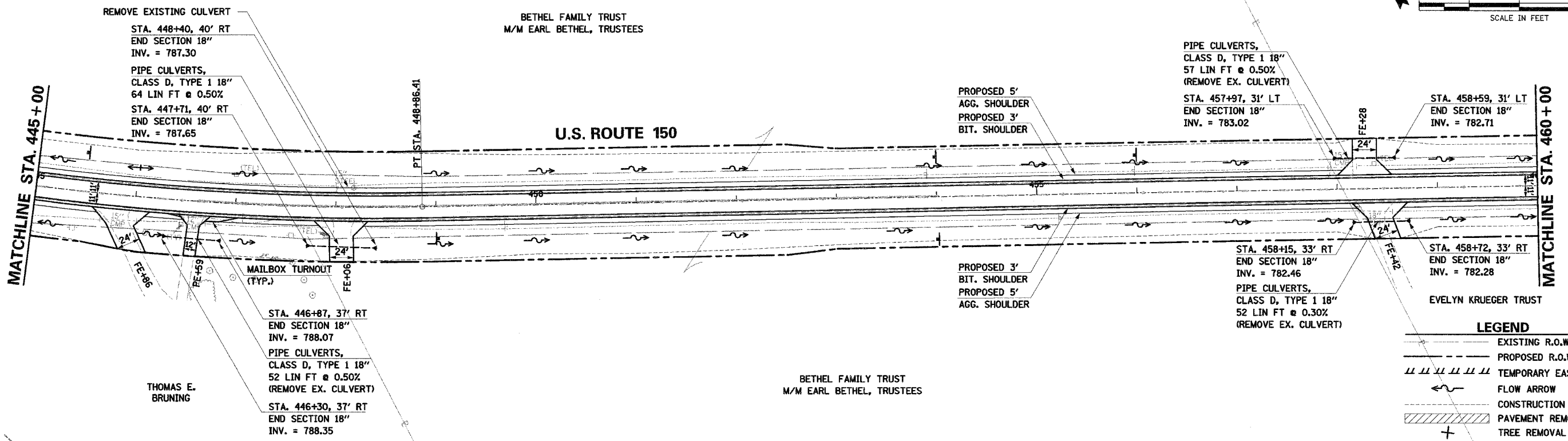

LEGEND

- EXISTING R.O.W.
- PROPOSED R.O.W.
- TEMPORARY EASEMENT
- FLOW ARROW
- CONSTRUCTION LIMITS
- PAVEMENT REMOVAL
- TREE REMOVAL

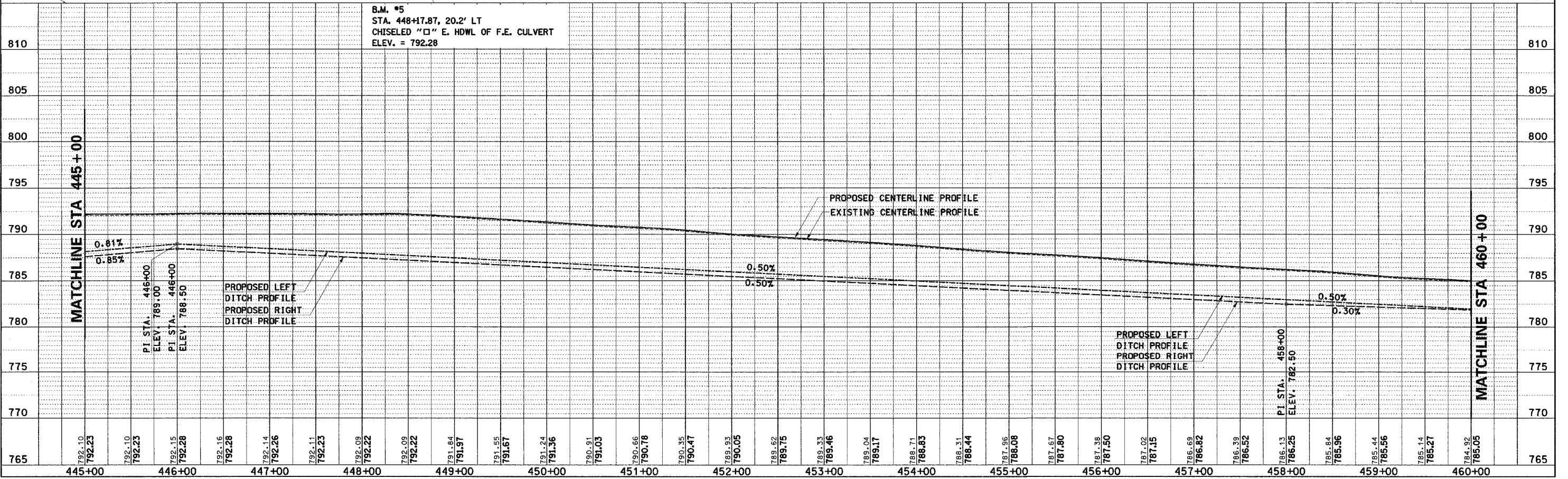

U.S. ROUTE 150 STA. 445+00 TO STA. 460+00 - PLAN AND PROFILE

F.A.S. RTE.	SECTION	COUNTY	TOTAL SHEETS	SHEET NO.
1517 (2)RS-3 (3)RS-4		MCLEAN	223	44
STA.	TO STA.			
FED. ROAD DIST. NO.	ILLINOIS FED. AID PROJECT			

66383

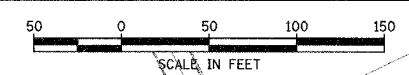

PLAN	SURVEYED	BY	DATE
	NOTE BOOK		
	ALIGNMENT CHECKED		
	OF THE		
	DATE FILE NAME		

PROFILE	GRADES CHECKED	BY	DATE
	PLAN, NOTES		
	STATUS USE		
	NOTATIONS (S/F)		

COMPANY NAME: #COMPANY, NAME #
 PROJECT CONTACT: #PROJECT, CONTACT #
 CLIENT: #CLIENT, #
 DATES: #DATES, #DATES

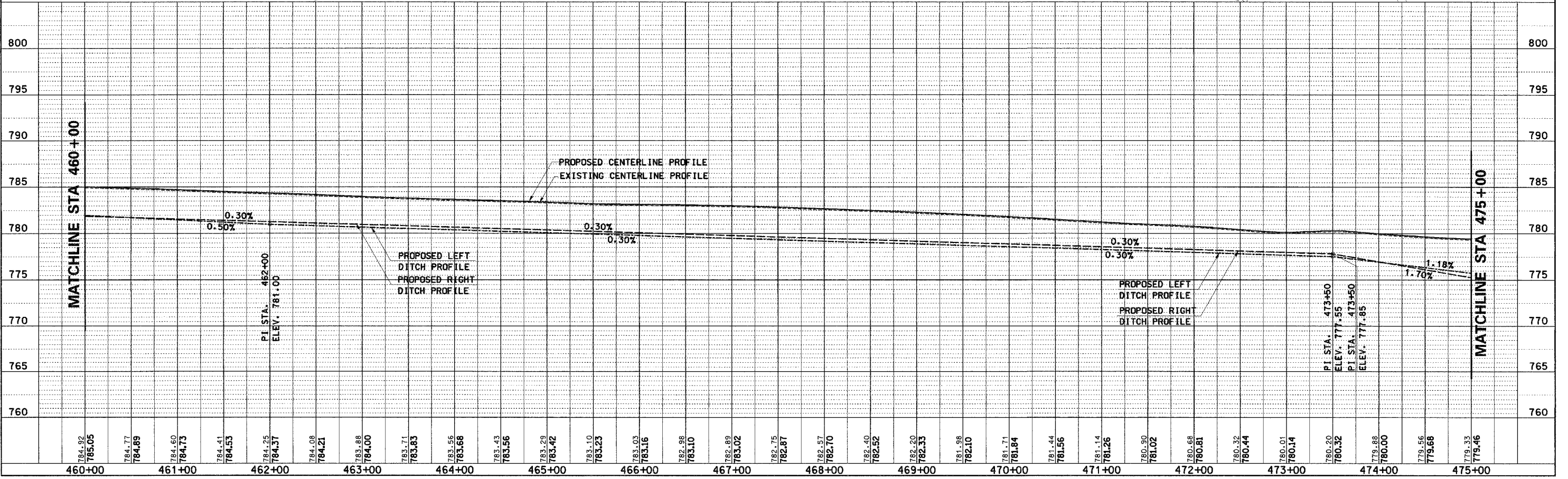
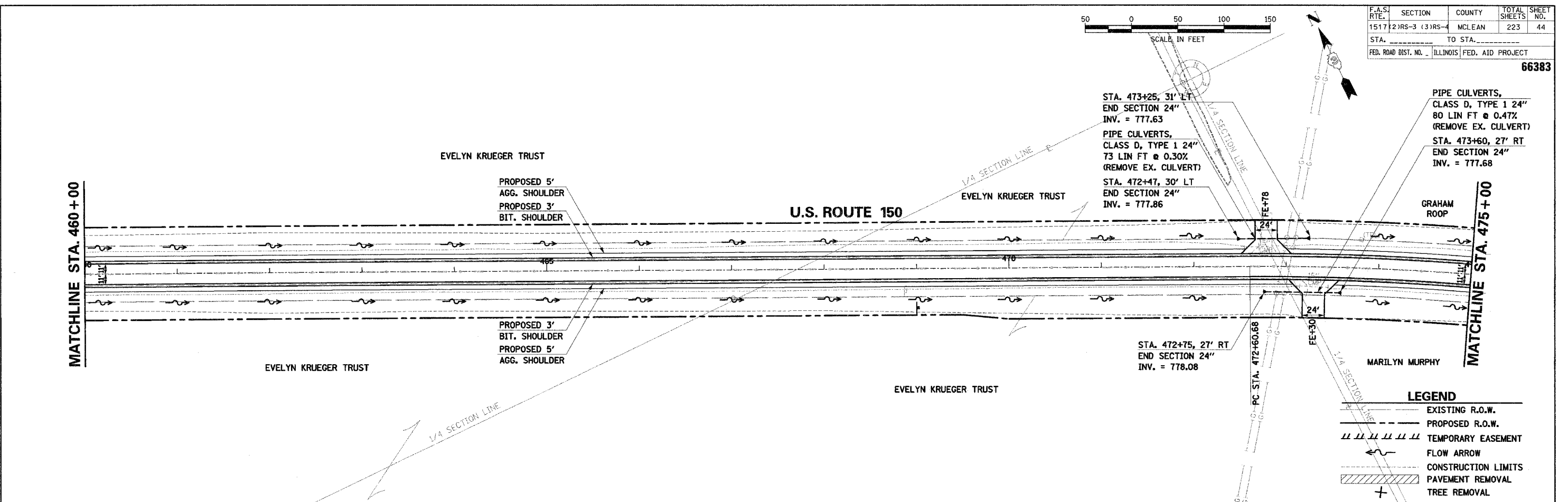

U.S. ROUTE 150 STA. 460+00 TO STA. 475+00 - PLAN AND PROFILE

F.A.S. RTE.	SECTION	COUNTY	TOTAL SHEETS	SHEET NO.
1517(2)RS-3	(3)RS-4	MCLEAN	223	45
STA. _____ TO STA. _____		FED. ROAD DIST. NO. _____ ILLINOIS FED. AID PROJECT		

66383

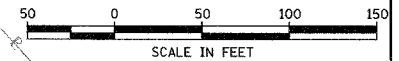

STONE DUMPED RIPRAP:
 1. ADJACENT TO THE STRUCTURE, ERODED BANKS OF LITTLE KICKAPOO SHALL GRADED TO RESTORE CHANNEL SHAPE.
 2. EXACT LOCATION FOR RIPRAP PLACEMENT SHALL BE DETERMINED BY THE ENGINEER.

PLAN	DATE
BY	
REVISIONS	
NO.	DESCRIPTION

PROFILE	DATE
BY	
REVISIONS	
NO.	DESCRIPTION

COMPANY NAME: #COMPANY NAME#
 PROJECT CONTACT: #PROJECT CONTACT#
 CLIENT: #CLIENT#
 DATES: #DATES#
 SHEETS: #SHEETS#

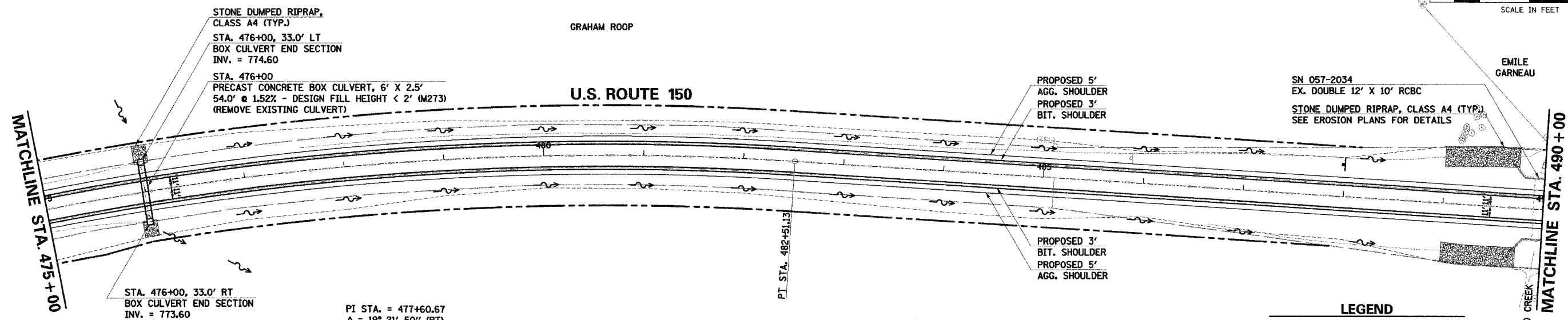

PI STA. = 477+60.67
 $\Delta = 19^\circ 21' 50''$ (RT)
 $D = 1^\circ 57' 18''$
 $R = 2,930.65'$
 $T = 499.99'$
 $L = 990.45'$
 $E = 42.35'$
 $e = 3.3\%$
 $T.R. = 37'$
 $S.E. RUN = 81'$
 $P.C. STA. = 472+60.68$
 $P.T. STA. = 482+51.13$

LEGEND

	EXISTING R.O.W.
	PROPOSED R.O.W.
	TEMPORARY EASEMENT
	FLOW ARROW
	CONSTRUCTION LIMITS
	PAVEMENT REMOVAL
	TREE REMOVAL

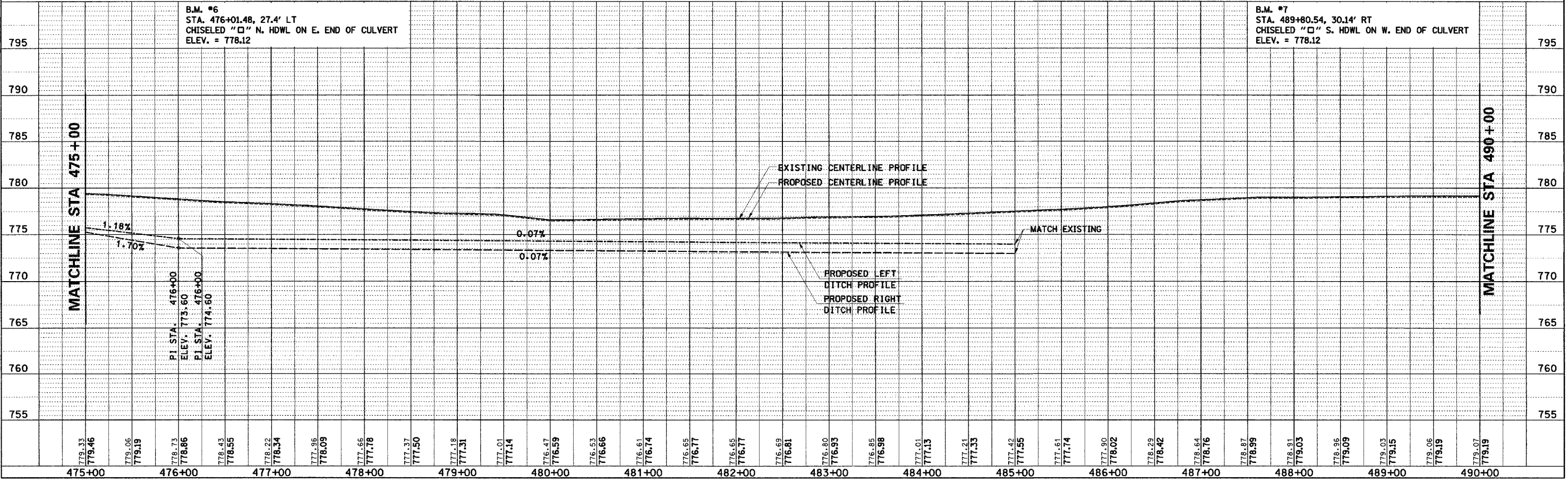

U.S. ROUTE 150 STA. 475+00 TO STA. 490+00 - PLAN AND PROFILE

F.A.S. RTE.	SECTION	COUNTY	TOTAL SHEETS	SHEET NO.
1517 (2)RS-3 (3)RS-4		MCLEAN	223	46
STA. _____ TO STA. _____		FED. ROAD DIST. NO. ILLINOIS FED. AID PROJECT		

66383

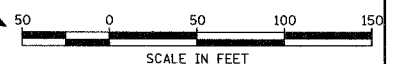

PI STA. = 493+86.01
 $\Delta = 7^\circ 14' 01''$ (LT)
 $D = 1^\circ 00' 16''$
 $R = 5,704.42'$
 $T = 360.57'$
 $L = 720.18'$
 $E = 11.38'$
 $\theta = 2.4\%$
 $T.R. = 37'$
 $S.E. RUN = 59'$
 $P.C. STA. = 490+25.44$
 $P.T. STA. = 497+45.62$

CHARLES I. AND MARILYN I. & MARILYN MURPHY

DATE	BY
DATE	BY

DATE	BY
DATE	BY

COMPANY NAME: COMPANY NAME
 PROJECT CONTACT: PROJECT CONTACT
 CLIENT: CLIENT
 DATE: DATE
 SHEET: SHEET

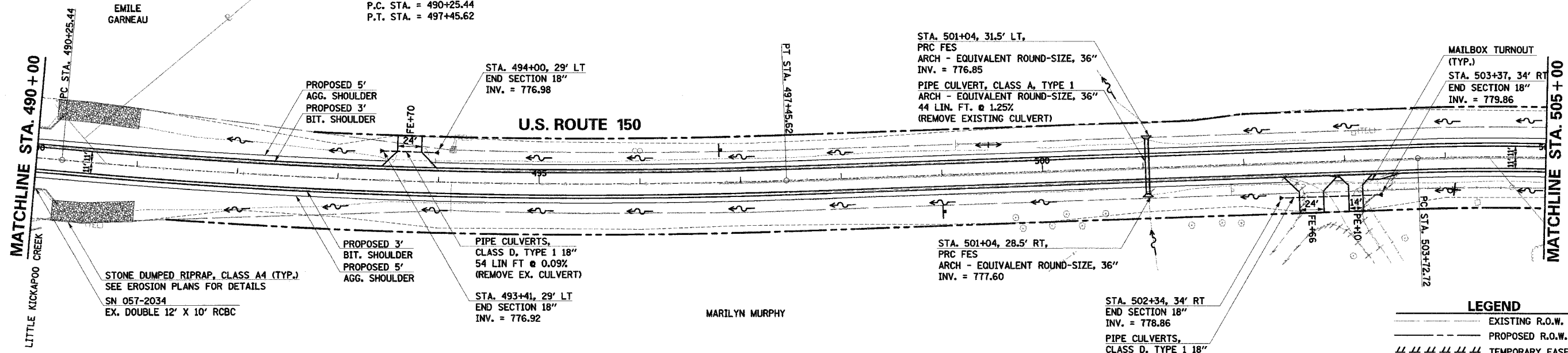

STONE DUMPED RIPRAP:
 1. ADJACENT TO THE STRUCTURE, ERODED BANKS OF LITTLE KICKAPOO CREEK SHALL BE GRADED TO RESTORE CHANNEL SHAPE.
 2. EXACT LOCATION FOR RIPRAP PLACEMENT SHALL BE DETERMINED BY THE ENGINEER.

LEGEND

	EXISTING R.O.W.
	PROPOSED R.O.W.
	TEMPORARY EASEMENT
	FLOW ARROW
	CONSTRUCTION LIMITS
	PAVEMENT REMOVAL
	TREE REMOVAL

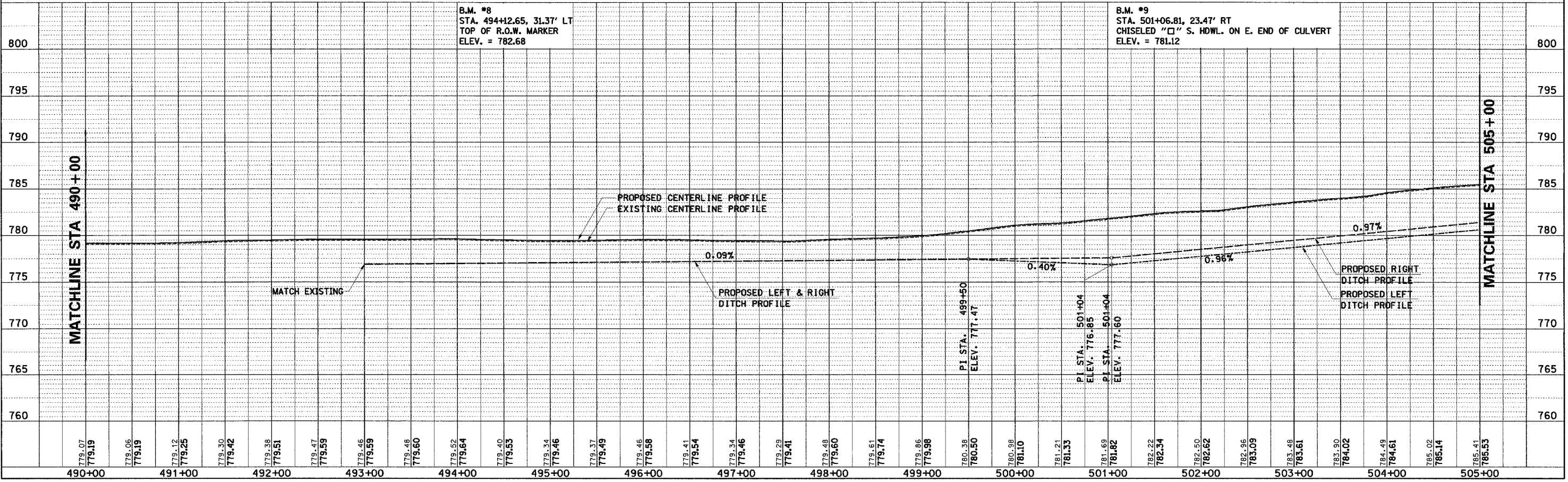

U.S. ROUTE 150 STA. 490+00 TO STA. 505+00 - PLAN AND PROFILE

F.A.S. RTE.	SECTION	COUNTY	TOTAL SHEETS	SHEET NO.
1517 (2)RS-3 (3)RS-4		MCLEAN	223	47
STA.	TO STA.			
FED. ROAD DIST. NO.	ILLINOIS FED. AID PROJECT		66383	

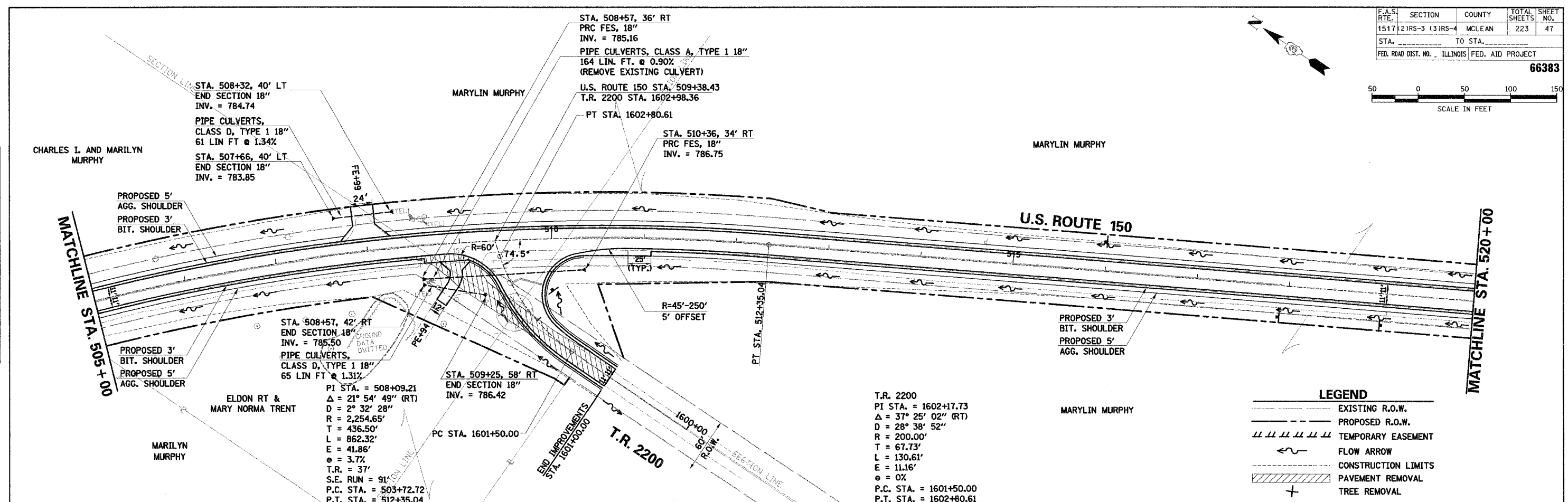
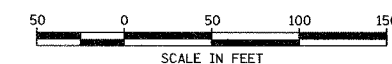

T.R. 2200
 PI STA. = 1602+17.73
 $\Delta = 37^\circ 25' 02''$ (RT)
 $D = 28^\circ 38' 52''$
 $R = 200.00'$
 $T = 67.73'$
 $L = 130.61'$
 $E = 11.16'$
 $e = 0\%$
 P.C. STA. = 1601+50.00
 P.T. STA. = 1602+80.61

LEGEND

- EXISTING R.O.W.
- PROPOSED R.O.W.
- TEMPORARY EASEMENT
- FLOW ARROW
- CONSTRUCTION LIMITS
- PAVEMENT REMOVAL
- TREE REMOVAL

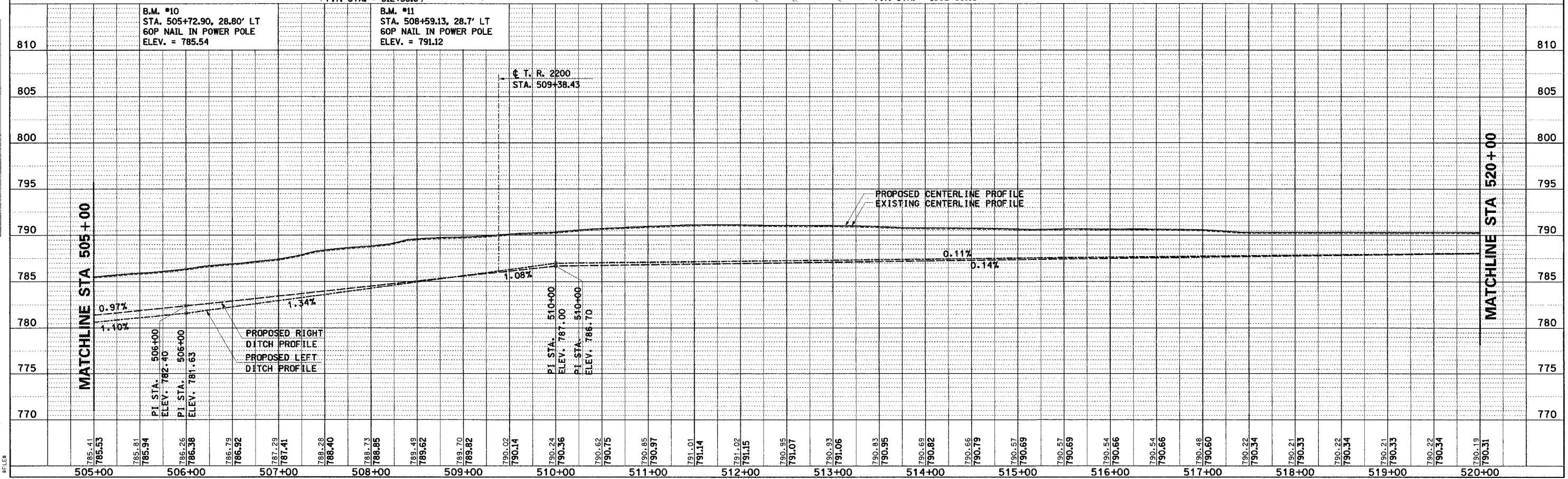

U.S. ROUTE 150 STA. 505+00 TO STA. 520+00 - PLAN AND PROFILE

DATE _____ BY _____
 SURVEYED _____
 PLAN _____
 NOTE BOOK _____
 CHECKED _____
 NO. _____

DATE _____ BY _____
 PROFILE _____
 GRADES CHECKED _____
 NOTE BOOK _____
 CHECKED _____
 NO. _____

COMPANY NAME: _____
 PROJECT CONTACT: _____
 CLIENT: _____
 DATE: _____
 SHEET: _____

DATE	
BY	
REVIEWED	
ALIGNED	
CHECKED	
NO.	
FILE NAME	

DATE	
BY	
REVIEWED	
GRADES CHECKED	
NO.	
NOTATIONS CHECKED	

COMPANY NAME: #COMPANY NAME#
 PROJECT CONTACT: #PROJECT CONTACT#
 CLIENT: #CLIENT#
 DATE: #DATE#
 SHEET: #SHEET#

PI STA. = 529+60.47
 $\Delta = 26^\circ 23' 32''$ (LT)
 $D = 2^\circ 41' 36''$
 $R = 2,127.40'$
 $T = 498.83'$
 $L = 979.95'$
 $E = 57.70'$
 $\theta = 3.8\%$
 $T.R. = 37'$
 $S.E. RUN = 93'$
 $P.C. STA. = 524+61.64$
 $P.T. STA. = 534+41.59$

F.A.S. RTE.	SECTION	COUNTY	TOTAL SHEETS	SHEET NO.
1517	(2)RS-3 (3)RS-4	MCLEAN	223	48
STA.	TO STA.			
FED. ROAD DIST. NO. - ILLINOIS FED. AID PROJECT				

66383

SCALE IN FEET

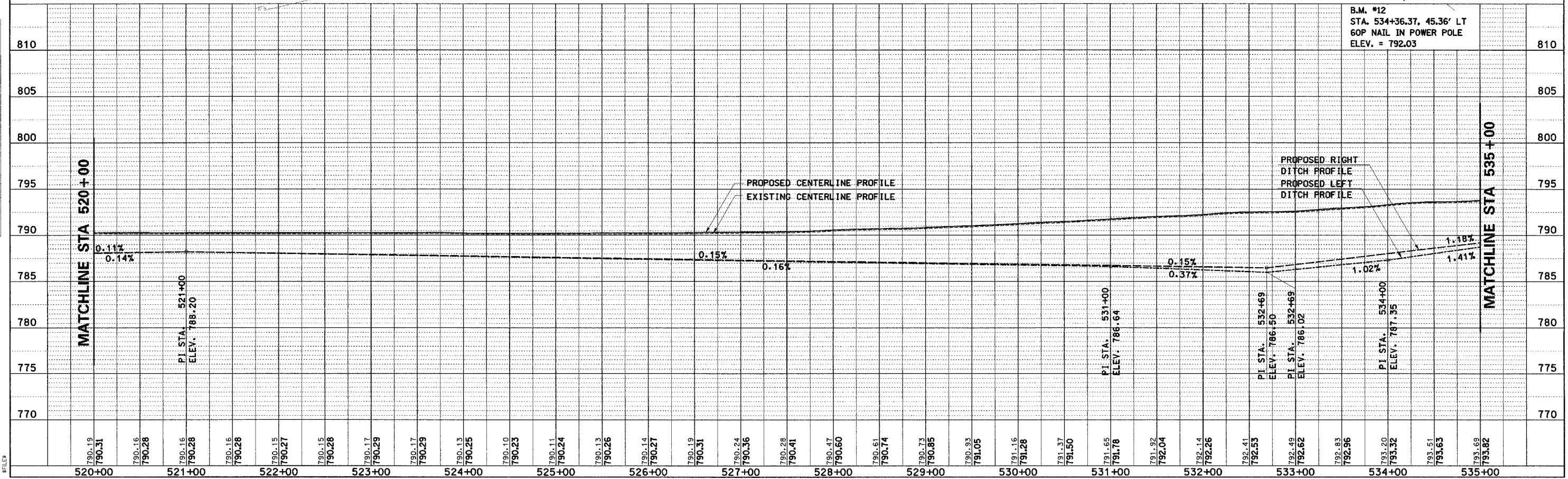
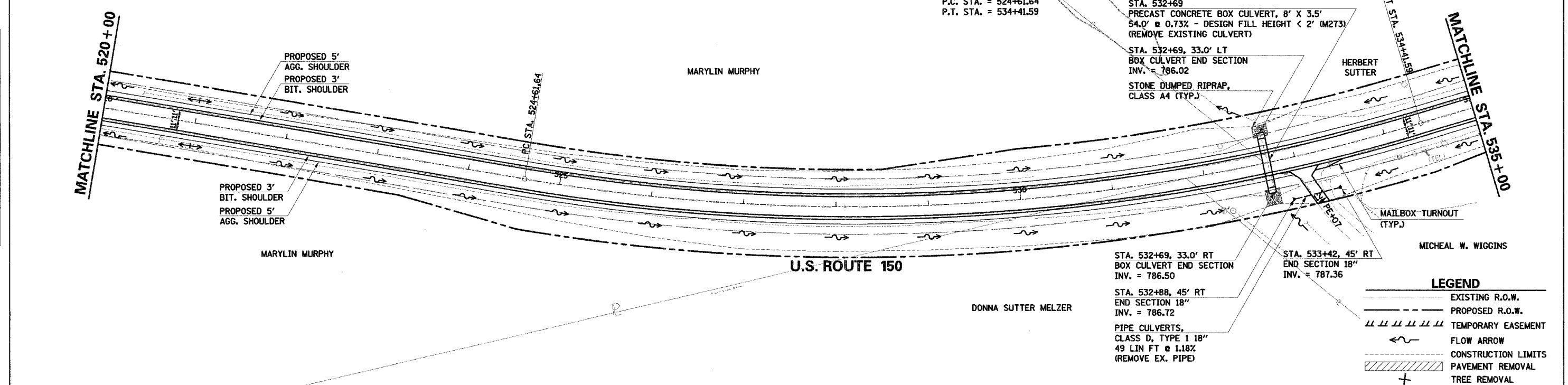

U.S. ROUTE 150 STA. 520+00 TO STA. 535+00 - PLAN AND PROFILE

F.A.S. RTE.	SECTION	COUNTY	TOTAL SHEETS	SHEET NO.
1517 (2)RS-3 (3)RS-4		MCLEAN	223	49
STA.	TO STA.			
FED. ROAD DIST. NO.	ILLINOIS FED. AID PROJECT			

66383

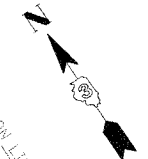
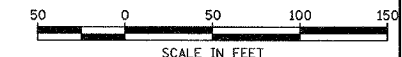

DATE	BY
DATE	BY

DATE	BY
DATE	BY

COMPANY NAME: #COMPANY NAME#
 PROJECT CONTACT: #PROJECT CONTACT#
 CLIENT: #CLIENT#
 DATE: #DATE#
 TIME: #TIME#

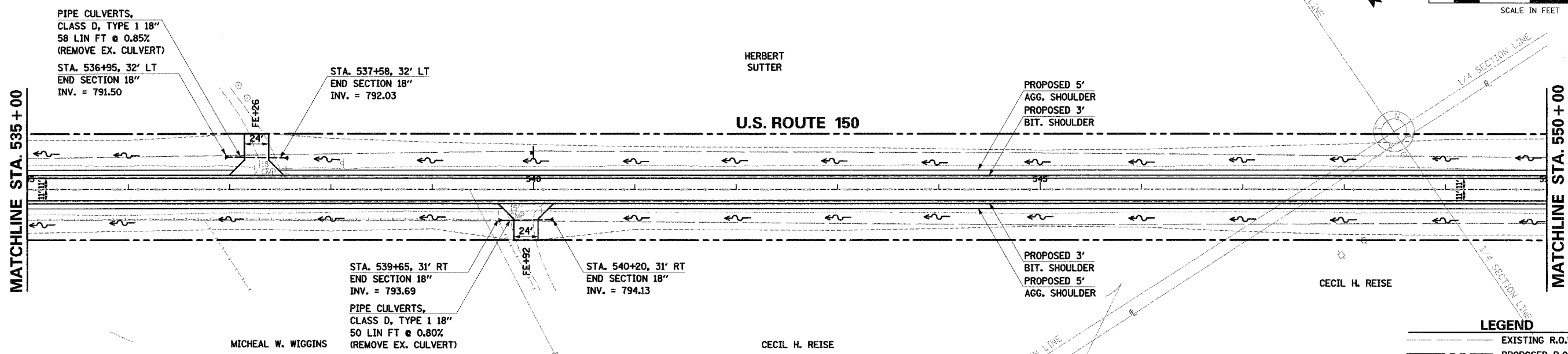

LEGEND

- EXISTING R.O.W.
- PROPOSED R.O.W.
- TEMPORARY EASEMENT
- FLOW ARROW
- CONSTRUCTION LIMITS
- PAVEMENT REMOVAL
- TREE REMOVAL

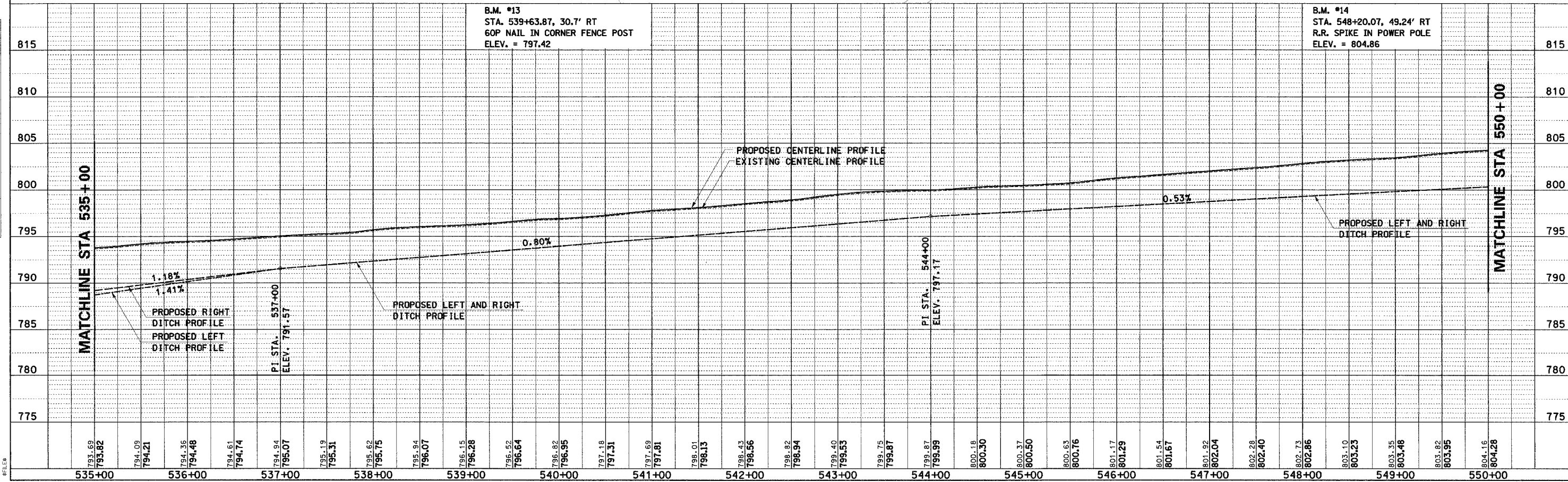

U.S. ROUTE 150 STA. 535+00 TO STA. 550+00 - PLAN AND PROFILE

F.A.S. SECTION COUNTY TOTAL SHEETS SHEET NO.
1517 (2)RS-3 (3)RS-4 MCLEAN 223 50
STA. _____ TO STA. _____
FED. ROAD DIST. NO. _____ ILLINOIS FED. AID PROJECT

66383

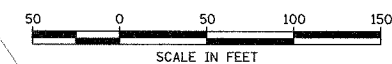

PI STA. = 556+24.28
 $\Delta = 1^\circ 18' 18''$ (LT)
 $D = 0^\circ 07' 26''$
 $R = 46,285.41'$
 $T = 527.13'$
 $L = 1,054.22'$
 $E = 3.00'$
 $e = NC$
P.C. STA. = 550+97.15
P.T. STA. = 561+51.37

CECIL H. REISE

STA. 560+42, 30' LT,
PRC FES
ARCH - EQUIVALENT ROUND-SIZE, 36"
INV. = 801.93

PIPE CULVERT, CLASS A, TYPE 1
ARCH - EQUIVALENT ROUND-SIZE, 36"
44 LIN. FT. @ 0.30%
(REMOVE EXISTING CULVERT)

DALE C. BAKER

STA. 564+68, 27' LT
END SECTION 18"
INV. = 802.95

PIPE CULVERTS,
CLASS D, TYPE 1 18"
43 LIN FT @ 0.20%
(REMOVE EX. CULVERT)

STA. 564+20, 27' LT
END SECTION 18"
INV. = 802.86

STA. 564+32, 28' RT
END SECTION 18"
INV. = 802.88

PIPE CULVERTS,
CLASS D, TYPE 1 18"
43 LIN FT @ 0.20%
(REMOVE EX. CULVERT)

STA. 564+80, 28' RT
END SECTION 18"
INV. = 802.98

STA. 560+42, 30' RT,
PRC FES
ARCH - EQUIVALENT ROUND-SIZE, 36"
INV. = 801.75

CECIL H. REISE

MATCHLINE STA. 550 + 00

MATCHLINE STA. 565 + 00

U.S. ROUTE 150

- LEGEND**
- EXISTING R.O.W.
 - - - PROPOSED R.O.W.
 - /// TEMPORARY EASEMENT
 - FLOW ARROW
 - - - CONSTRUCTION LIMITS
 - /// PAVEMENT REMOVAL
 - + TREE REMOVAL

PLAN	SURVEYED	DATE
NO.	BY	
NO.	BY	
NO.	BY	

PROFILE	SURVEYED	DATE
NO.	BY	
NO.	BY	
NO.	BY	

COMPANY NAME	DATE
PROJECT CONTACT	BY
CLIENT	BY
DATE	BY

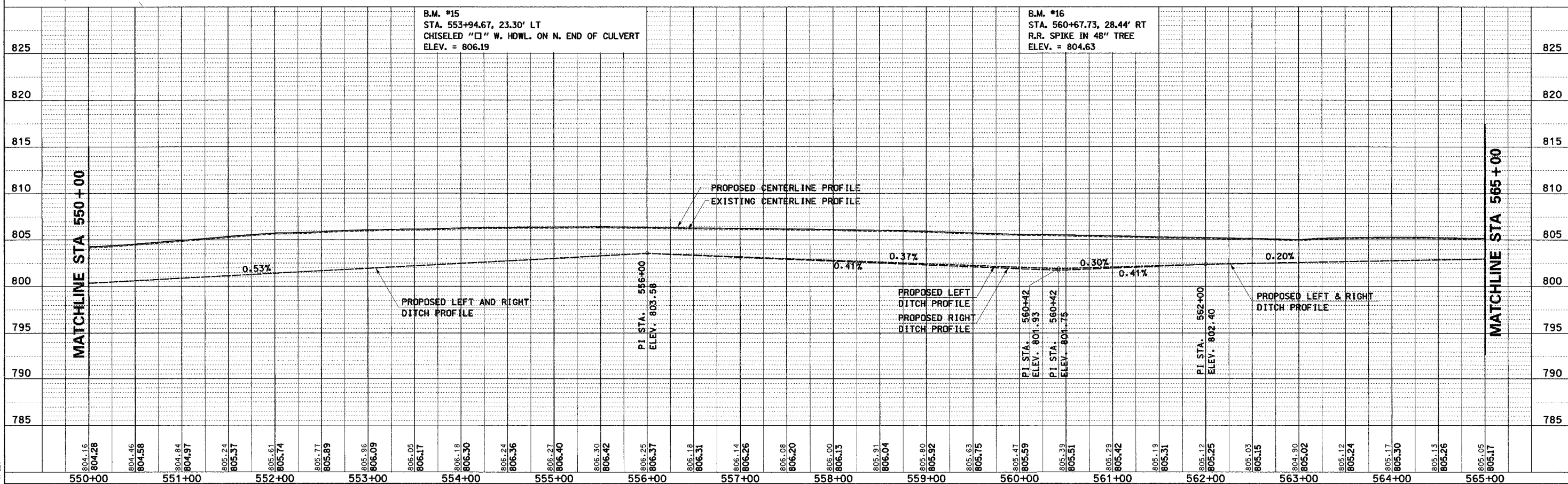

U.S. ROUTE 150 STA. 550+00 TO STA. 565+00 - PLAN AND PROFILE

F.A.S. RTE.	SECTION	COUNTY	TOTAL SHEETS	SHEET NO.
1517 (2)RS-3 (3)RS-4	MCLEAN	223	51	
STA.	TO STA.			
FED. ROAD DIST. NO.		ILLINOIS FED. AID PROJECT		

66383

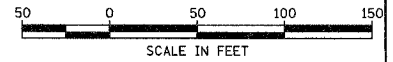

DATE	BY
DATE	BY
DATE	BY

DATE	BY
DATE	BY
DATE	BY

COMPANY NAME: #COMPANY NAME#
 PROJECT CONTACT: #PROJECT CONTACT#
 CLIENT: #CLIENT#
 DATE: #DATE#
 TIME: #TIME#

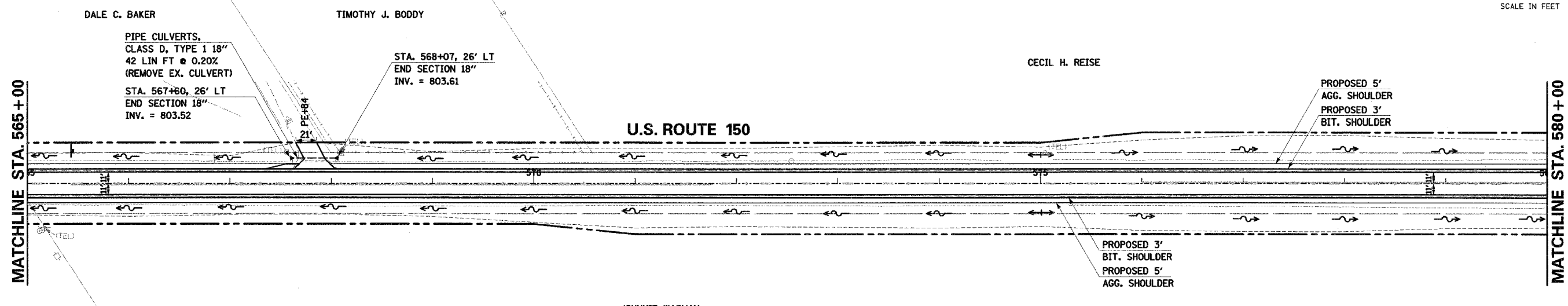

LEGEND

	EXISTING R.O.W.
	PROPOSED R.O.W.
	TEMPORARY EASEMENT
	FLOW ARROW
	CONSTRUCTION LIMITS
	PAVEMENT REMOVAL
	TREE REMOVAL

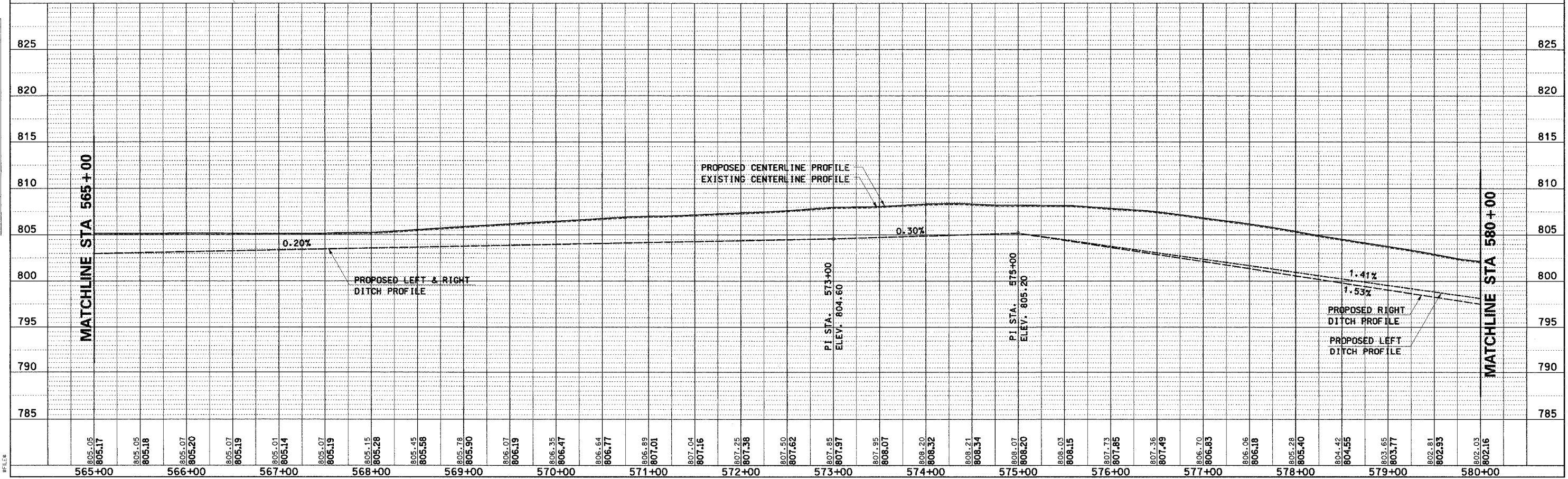

U.S. ROUTE 150 STA. 565+00 TO STA. 580+00 - PLAN AND PROFILE

F.A.S. RTE.	SECTION	COUNTY	TOTAL SHEETS	SHEET NO.
1517 (2)RS-3 (3)RS-4		MCLEAN	223	52
STA.	TO STA.			
FED. ROAD DIST. NO.	ILLINOIS FED. AID PROJECT			

66383

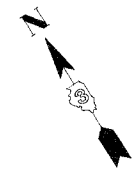
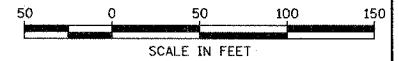

DATE	BY	SURVEYED	ALIGNED	CHECKED	DESIGNED
PLAN		NOTE BOOK			
		NO. _____			

DATE	BY	PROFILER	GRADES CHECKED	NOTATION

COMPANY NAME: #COMPANY NAME#
 PROJECT CONTACT: #PROJECT CONTACT#
 CLIENT: #CLIENT#
 DATE: #DATE#
 SHEET: #SHEET#

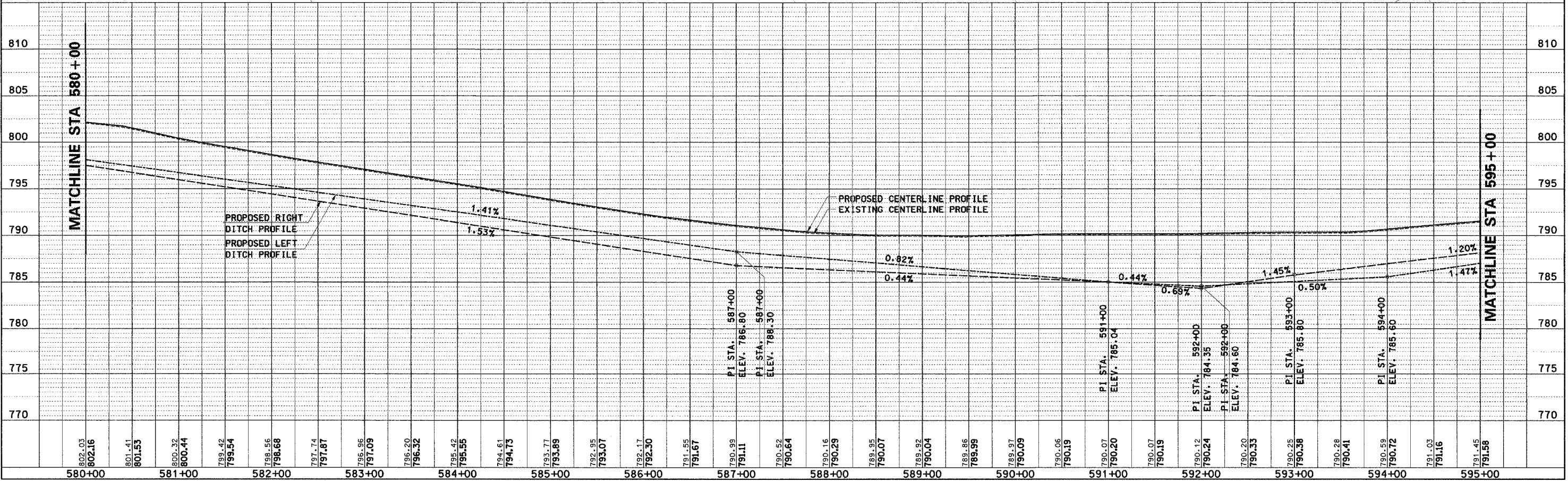
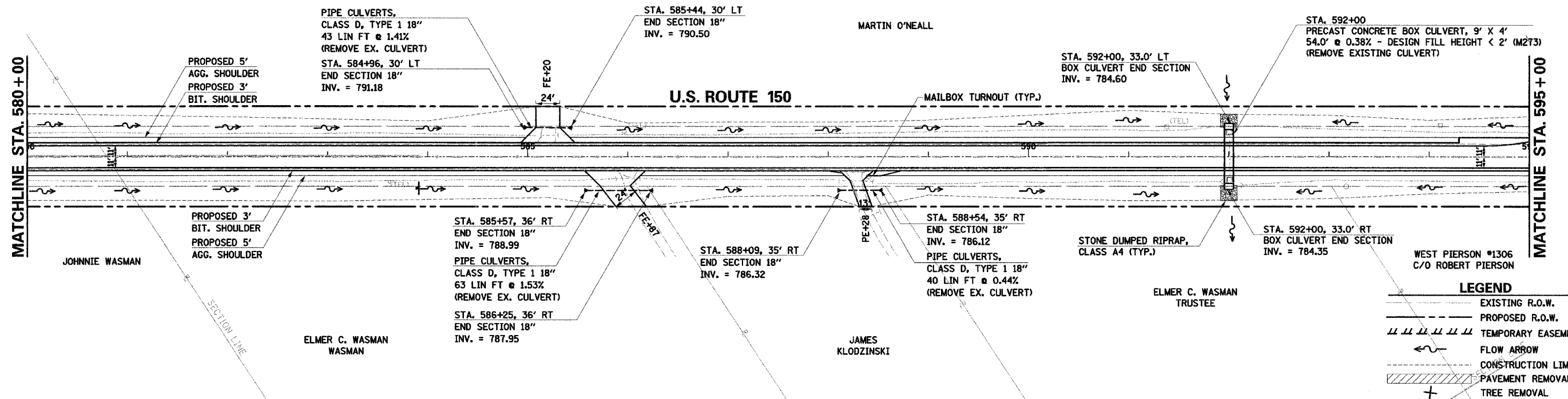

U.S. ROUTE 150 STA. 580+00 TO STA. 595+00 - PLAN AND PROFILE

DATE: _____ BY: _____
 SURVEYED _____
 PLAN _____
 NOTE BOOK _____
 NO. _____

DATE: _____ BY: _____
 SURVEYED _____
 PROFILE _____
 NOTE BOOK _____
 NO. _____

COMPANY NAME: #COMPANY NAME#
 PROJECT CONTACT: #PROJECT CONTACT#
 CLIENT: #CLIENT#
 #DATE# #TIME#
 #FILE#

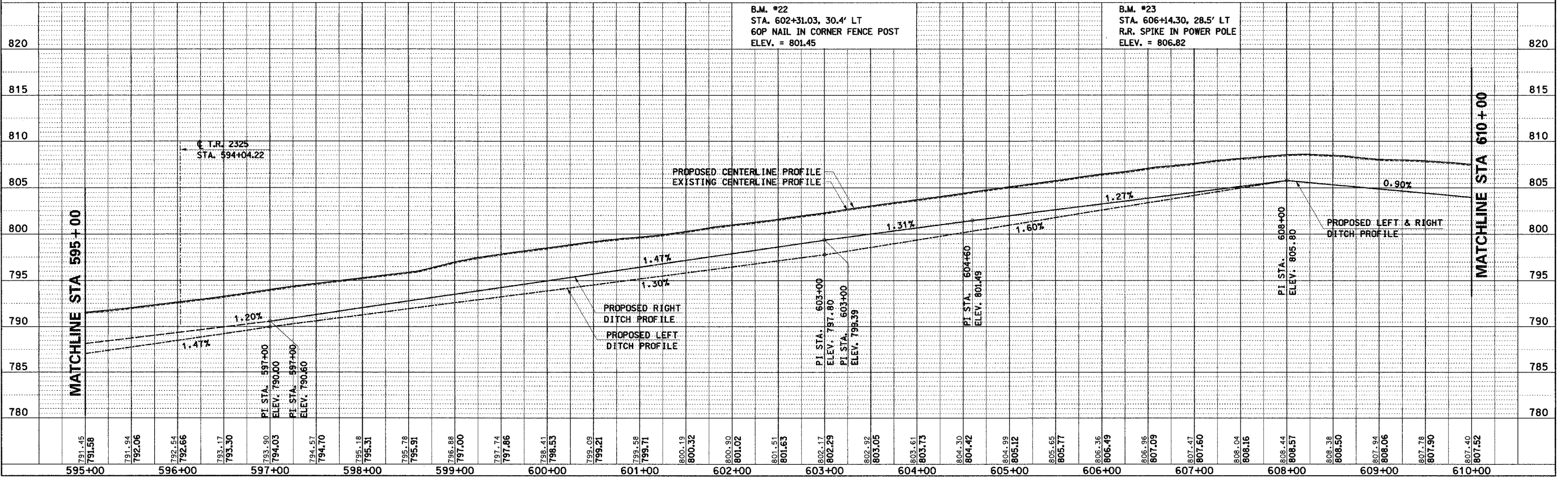
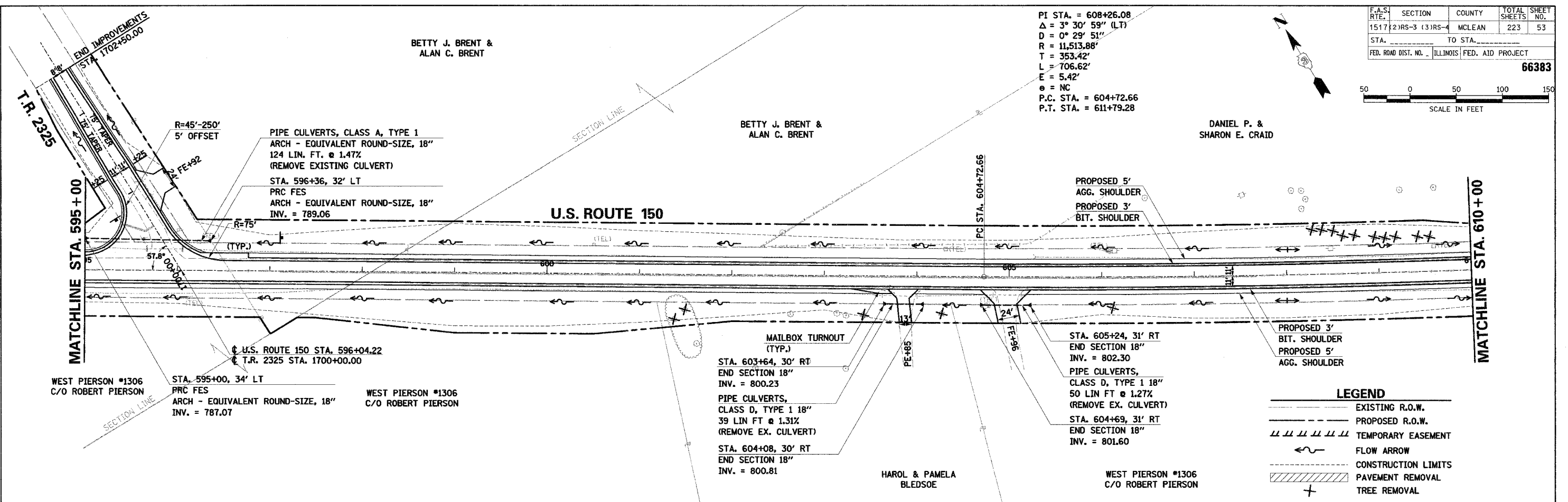

U.S. ROUTE 150 STA. 595+00 TO STA. 610+00 - PLAN AND PROFILE

F.A.S. RTE.	SECTION	COUNTY	TOTAL SHEETS	SHEET NO.
1517	2)RS-3 (13)RS-4	MCLEAN	223	53
STA. _____ TO STA. _____				
FED. ROAD DIST. NO. _____		ILLINOIS FED. AID PROJECT		

66383

SCALE IN FEET

DATE	
BY	
REVISION	
NO.	
DATE	
BY	
REVISION	
NO.	
DATE	
BY	
REVISION	
NO.	

DATE	
BY	
REVISION	
NO.	
DATE	
BY	
REVISION	
NO.	
DATE	
BY	
REVISION	
NO.	

COMPANY NAME: #COMPANY NAME#
 PROJECT CONTACT: #PROJECT CONTACT#
 CLIENT: #CLIENT#
 DATE: #DATE#
 BY: #BY#

PI STA. = 624+31.63
 $\Delta = 6^\circ 13' 35''$ (LT)
 $D = 0^\circ 36' 09''$
 $R = 9,508.92'$
 $T = 517.17'$
 $L = 1,033.32'$
 $E = 14.05'$
 $e = 1.5\%$
 $T.R. = 37'$
 $S.E. RUN = 37'$
 $P.C. STA. = 619+14.46$
 $P.T. STA. = 629+47.78$

F.A.S. SECTION COUNTY TOTAL SHEETS SHEET NO.
1517(2)RS-3 (3)RS-4 MCLEAN 223 54
STA. TO STA.
FED. ROAD DIST. NO. ILLINOIS FED. AID PROJECT

66383

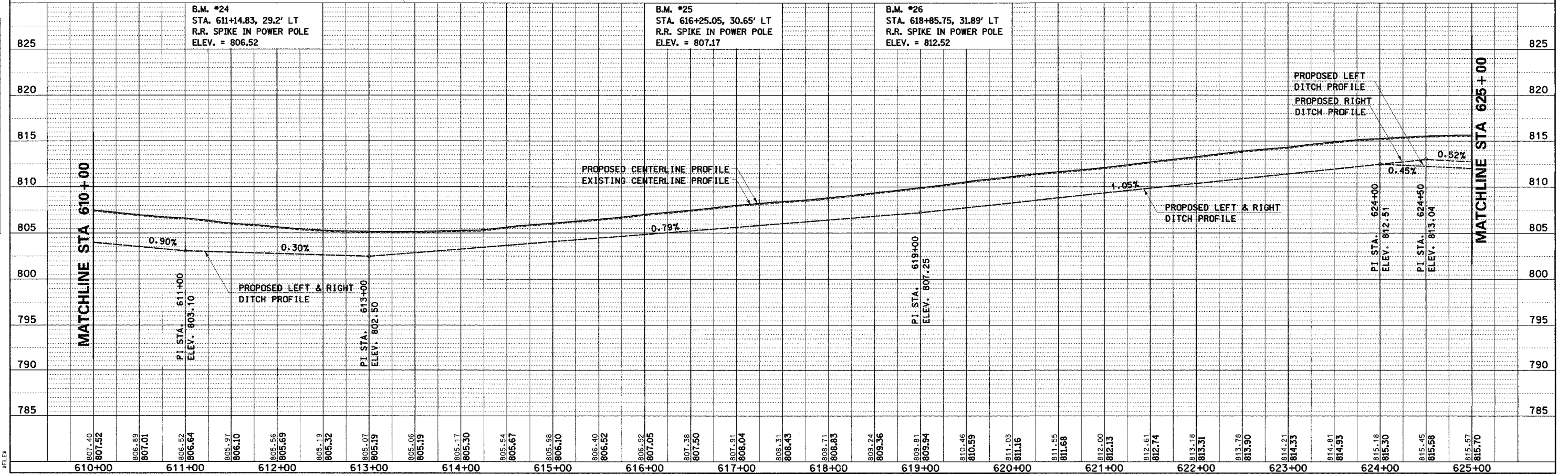
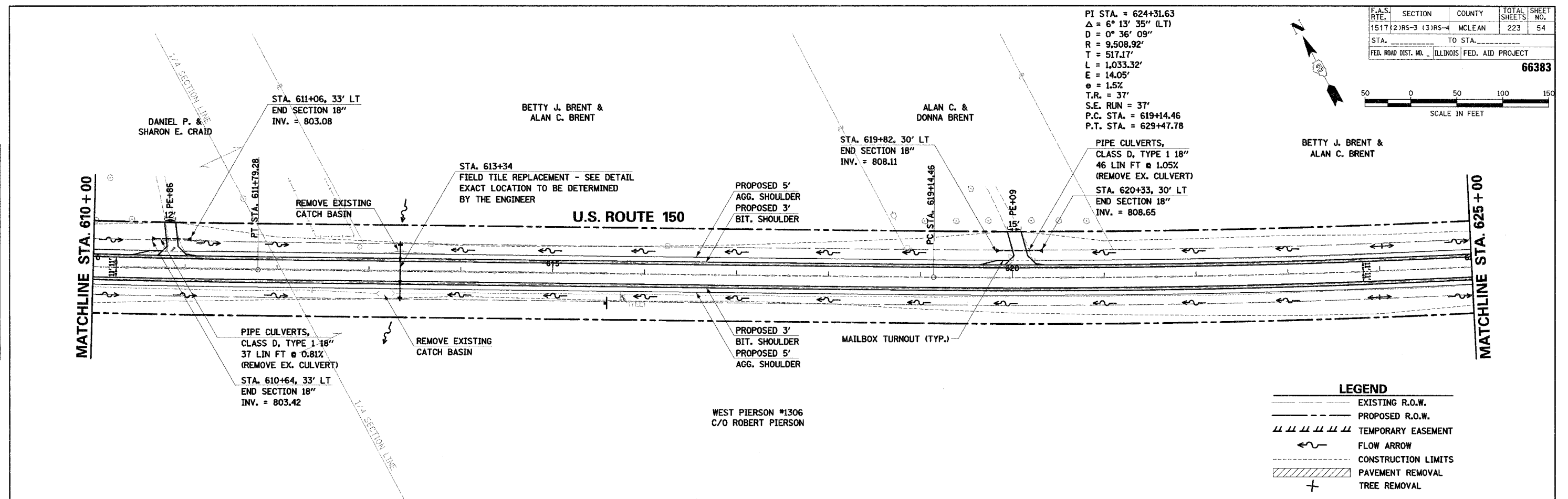
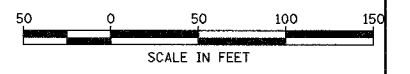

U.S. ROUTE 150 STA. 610+00 TO STA. 625+00 - PLAN AND PROFILE

F.A.S. RTE.	SECTION	COUNTY	TOTAL SHEETS	SHEET NO.
1517 (2)RS-3 (3)RS-4		MCLEAN	223	55
STA. _____ TO STA. _____				
FED. ROAD DIST. NO. - ILLINOIS		FED. AID PROJECT		

66383

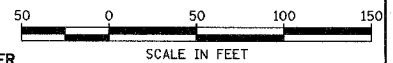

DATE	BY	REVISION

DATE	BY	REVISION

COMPANY NAME: #COMPANY NAME#
 PROJECT CONTACT: #PROJECT CONTACT#
 CLIENT: #CLIENT#
 DATE: #DATE#
 SHEET: #SHEET#

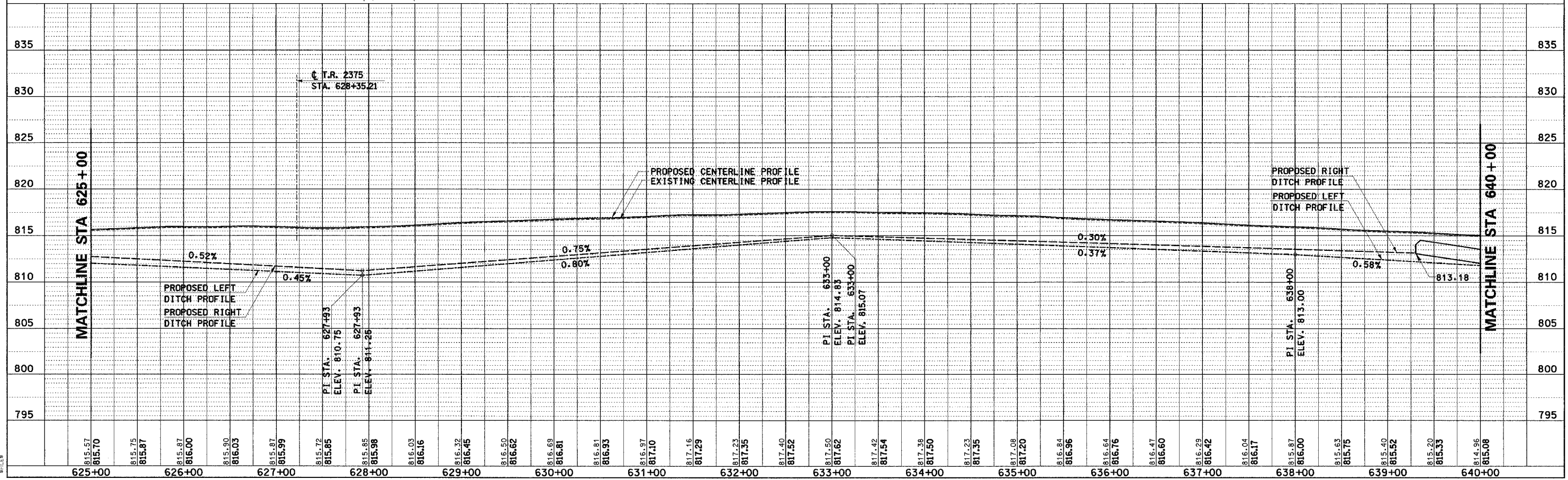
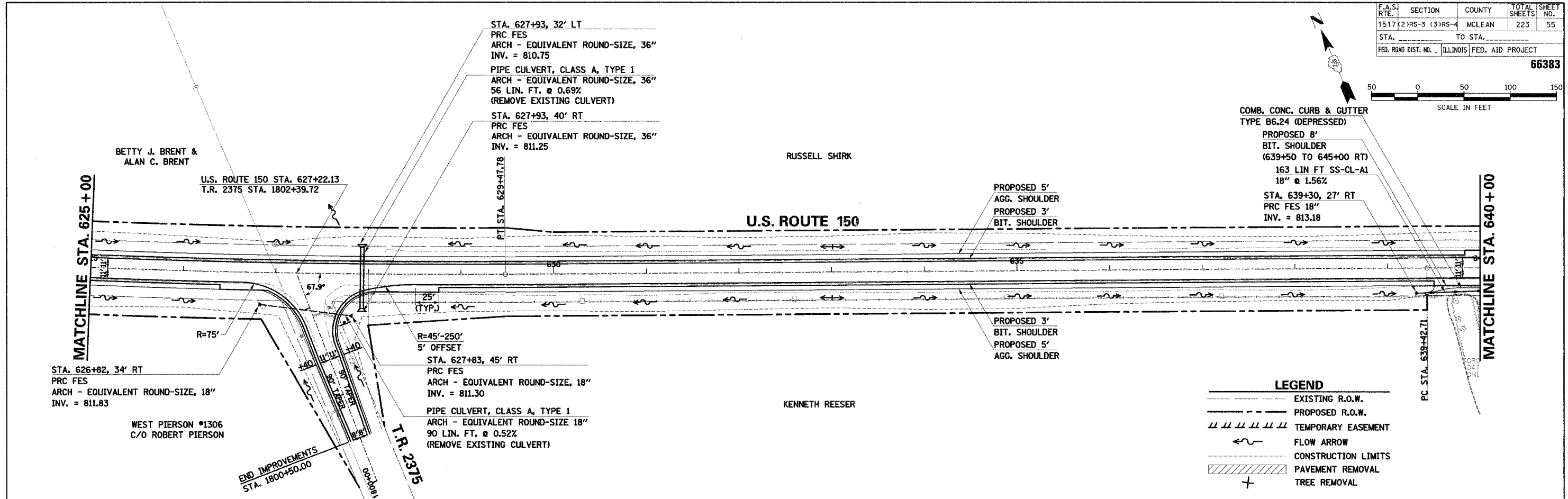

U.S. ROUTE 150 STA. 625+00 TO STA. 640+00 - PLAN AND PROFILE

F.A.S. RTE.	SECTION	COUNTY	TOTAL SHEETS	SHEET NO.
1517 (2)RS-3 (3)RS-4	MCLEAN	223	56	
STA.	TO STA.			
FED. ROAD DIST. NO.		ILLINOIS FED. AID PROJECT		

66383

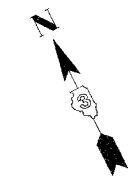
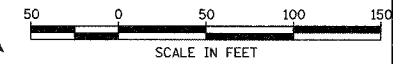

PLAN	DATE
BY	
CHECKED	
APPROVED	
DESIGNED	
NOTED	
NO.	

PROFILE	DATE
BY	
CHECKED	
APPROVED	
DESIGNED	
NOTED	
NO.	

COMPANY NAME: #COMPANY NAME#
 PROJECT CONTACT: #PROJECT CONTACT#
 CLIENT: #CLIENT#
 DATE: #DATE#
 TIME: #TIME#

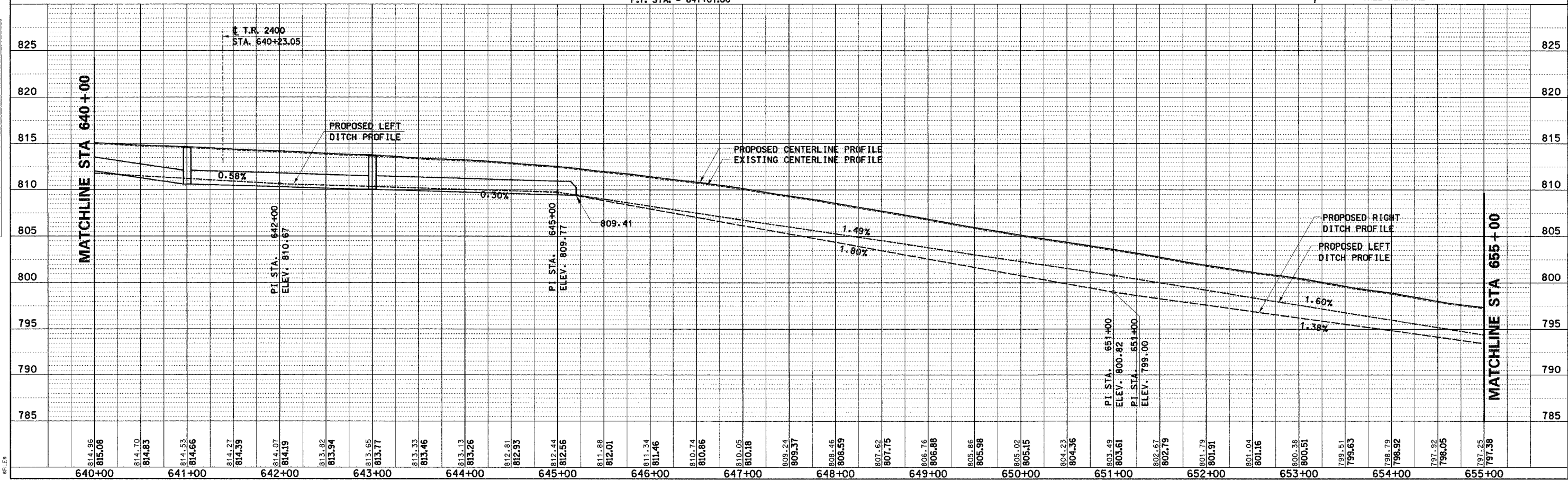
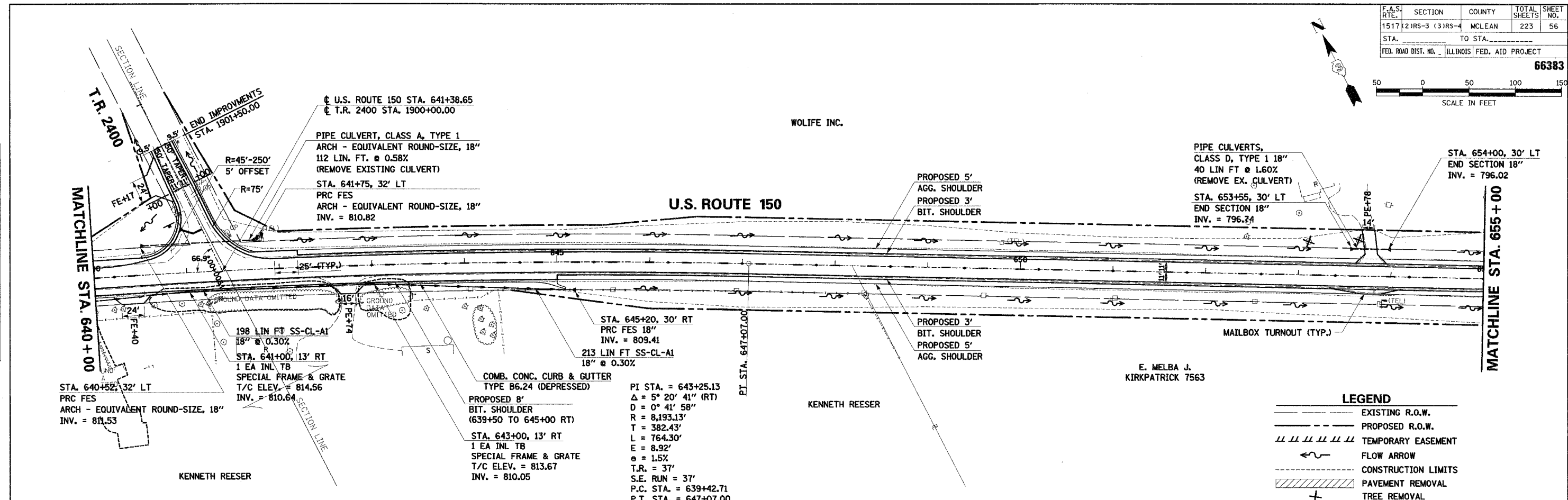

U.S. ROUTE 150 STA. 640+00 TO STA. 655+00 - PLAN AND PROFILE

F.A.S. RTE.	SECTION	COUNTY	TOTAL SHEETS	SHEET NO.
1517 (2)RS-3 (3)RS-4		MCLEAN	223	57
STA.	TO STA.			
FED. ROAD DIST. NO.	ILLINOIS FED. AID PROJECT			

66383

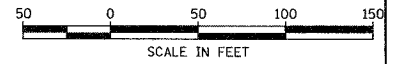

DATE	BY
SURVEYED	ALIGNED
CHECKED	CHECKED
NO.	NO.
PLAN	NOTE BOOK

DATE	BY
SURVEYED	GRADES CHECKED
CHECKED	CHECKED
NO.	NO.
PROFILE	NOTE BOOK

COMPANY NAME: #COMPANY NAME#
 PROJECT CONTACT: #PROJECT CONTACT#
 CLIENT: #CLIENT#
 DATES: #DATES#
 SHEET: #SHEET#

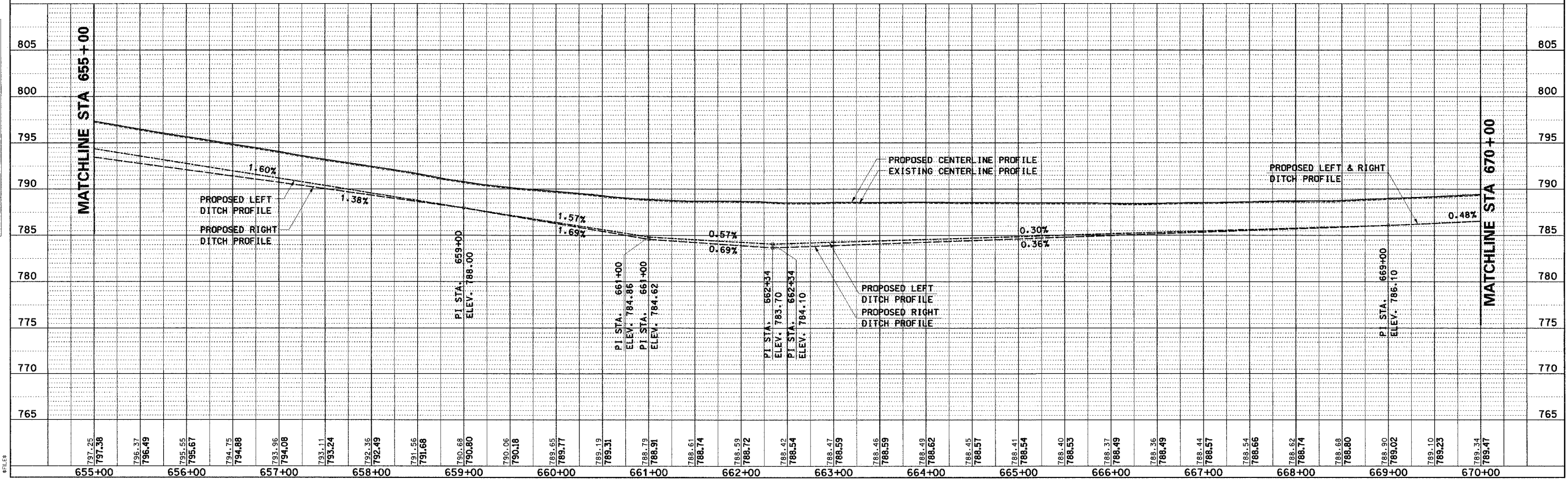
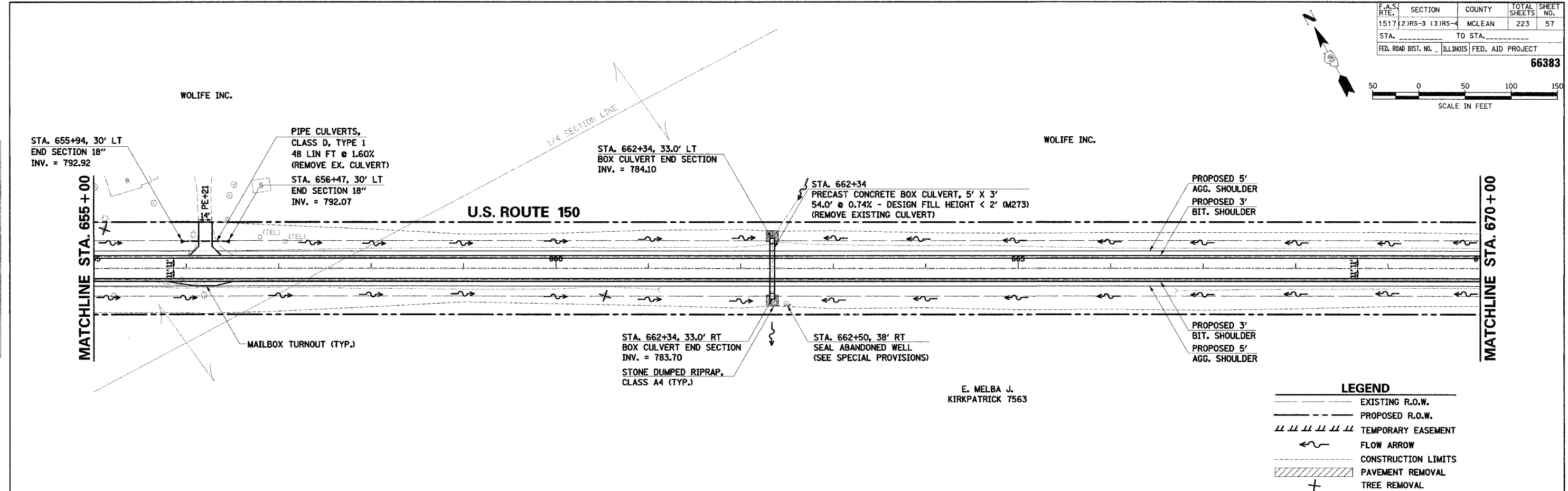

LEGEND

- EXISTING R.O.W.
- PROPOSED R.O.W.
- TEMPORARY EASEMENT
- FLOW ARROW
- CONSTRUCTION LIMITS
- PAVEMENT REMOVAL
- TREE REMOVAL

U.S. ROUTE 150 STA. 655+00 TO STA. 670+00 - PLAN AND PROFILE

DATE: _____
 BY: _____
 SURVEYED: _____
 PLAN: _____
 NO. _____
 CHECKED: _____
 DATE: _____
 FILE NO. _____

DATE: _____
 BY: _____
 SURVEYED: _____
 PROFILE: _____
 NO. _____
 CHECKED: _____
 DATE: _____
 FILE NO. _____

COMPANY NAME: #COMPANY NAME#
 PROJECT CONTACT: #PROJECT CONTACT#
 CLIENT: #CLIENT#
 #DATE# #TIME#
 #FILE#

PI STA. = 683+78.82
 $\Delta = 10^\circ 52' 53''$ (LT)
 $D = 1^\circ 05' 59''$
 $R = 5,210.05'$
 $T = 496.22'$
 $L = 989.46'$
 $E = 23.58'$
 $\theta = 2.57'$
 $T.R. = 37'$
 $S.E. RUN = 62'$
 $P.C. STA. = 678+82.59$
 $P.T. STA. = 688+72.05$

F.A.S. RT.	SECTION	COUNTY	TOTAL SHEETS	SHEET NO.
1517 (2)RS-3 (3)RS-4		MCLEAN	223	58
STA. _____ TO STA. _____				
FED. ROAD DIST. NO. _____ ILLINOIS		FED. AID PROJECT		

66383

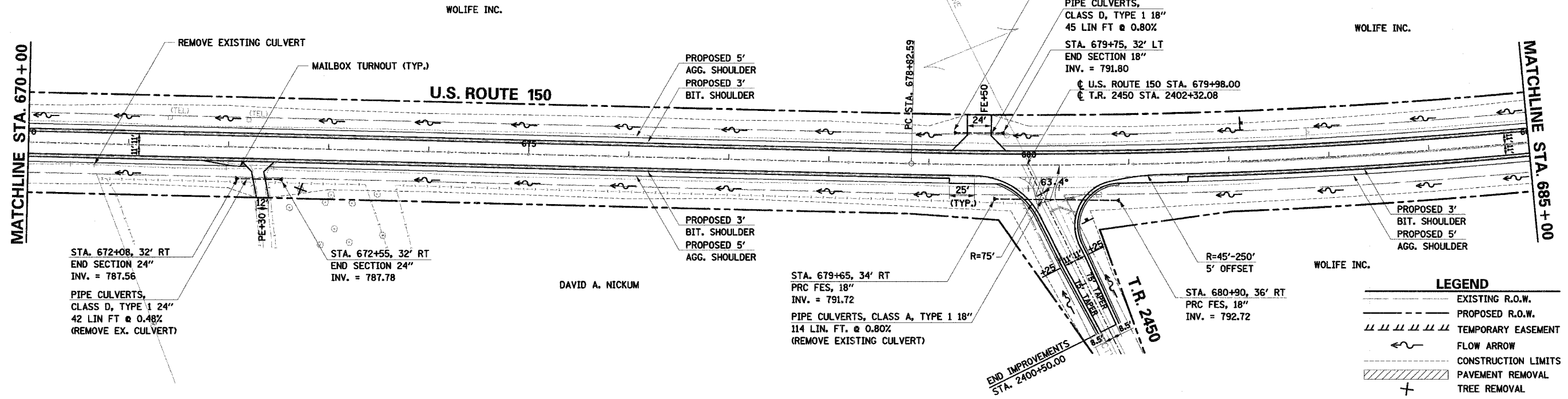
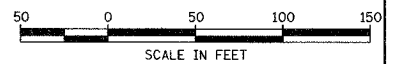

LEGEND

- EXISTING R.O.W.
- - - PROPOSED R.O.W.
- /// TEMPORARY EASEMENT
- ~ FLOW ARROW
- - - CONSTRUCTION LIMITS
- /// PAVEMENT REMOVAL
- + TREE REMOVAL

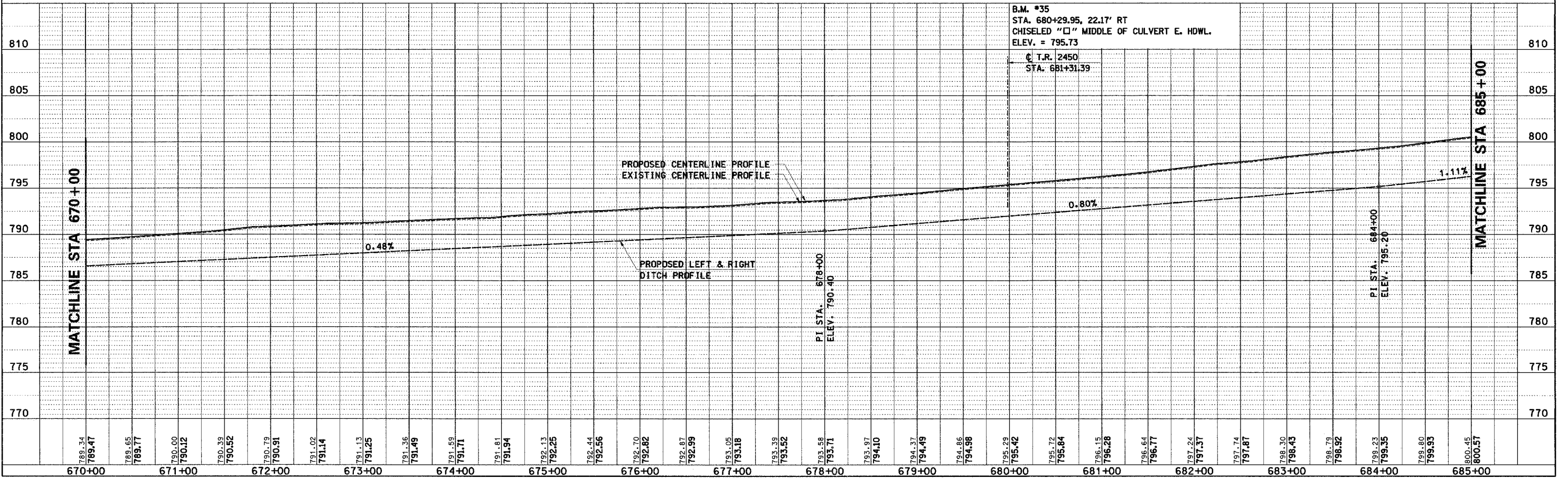

U.S. ROUTE 150 STA. 670+00 TO STA. 685+00 - PLAN AND PROFILE

F.A.S. RTE. 1517 (2)RS-3 (3)RS-4	SECTION MCLEAN	COUNTY MCLEAN	TOTAL SHEETS 223	SHEET NO. 59
STA. _____ TO STA. _____		ILLINOIS FED. AID PROJECT		

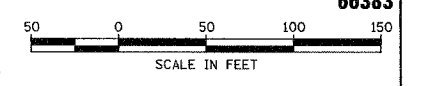

66383

DATE	BY
DATE	BY

DATE	BY
DATE	BY

COMPANY NAME: COMPANY, INC.
 PROJECT CONTACT: PROJECT CONTACTS
 CLIENT: CLIENT/NO.
 DATE: DATE/STATION
 FILE:

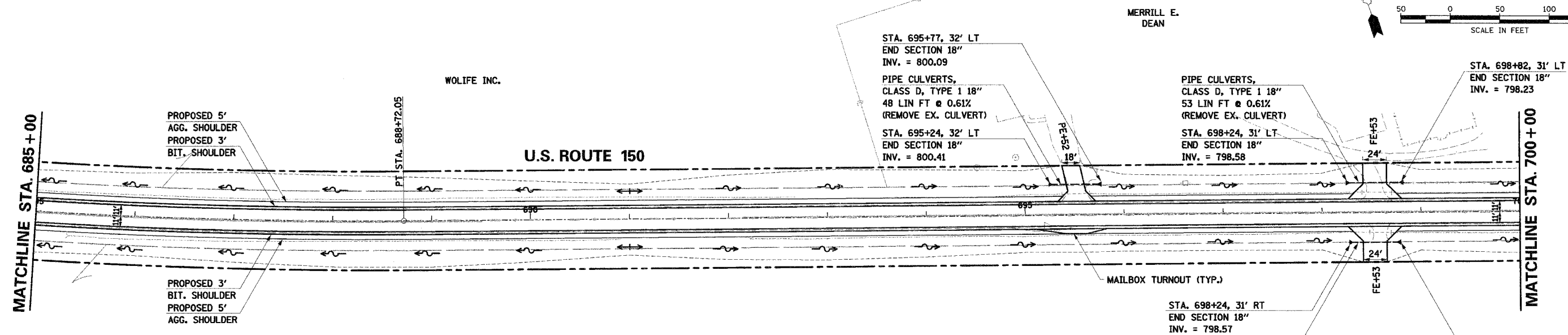

LEGEND

- EXISTING R.O.W.
- - - PROPOSED R.O.W.
- /// TEMPORARY EASEMENT
- FLOW ARROW
- - - CONSTRUCTION LIMITS
- ▨ PAVEMENT REMOVAL
- + TREE REMOVAL

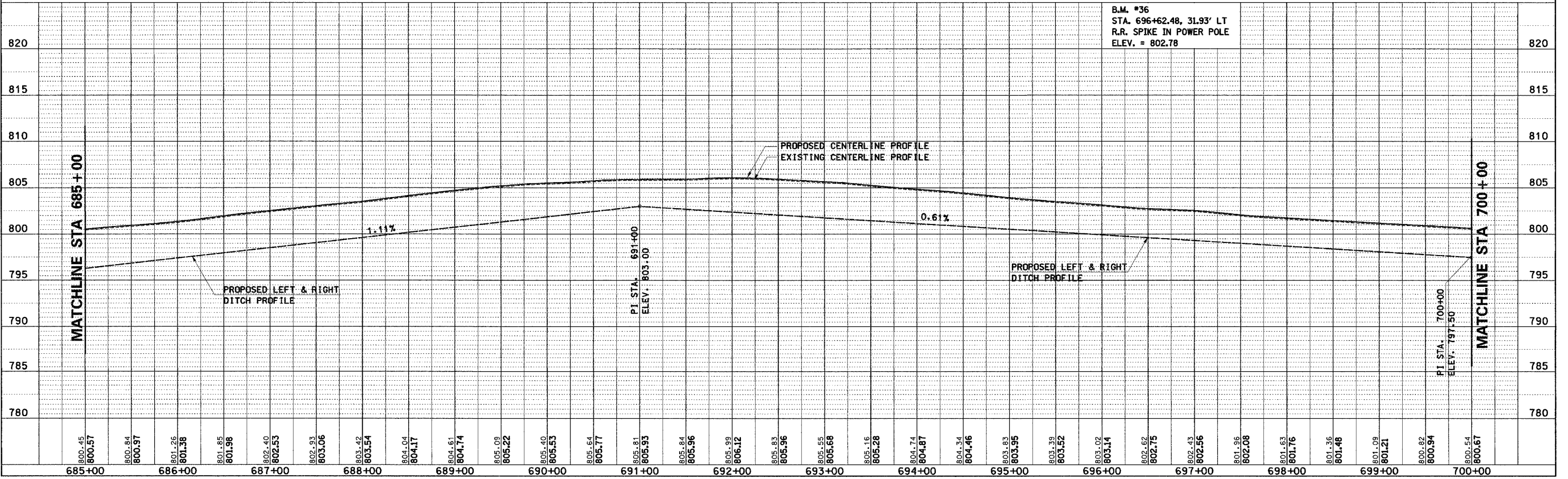

U.S. ROUTE 150 STA. 685+00 TO STA. 700+00 - PLAN AND PROFILE

F.A.S. RTE.	SECTION	COUNTY	TOTAL SHEETS	SHEET NO.
1517 (2)RS-3 (3)RS-4	MCLEAN	223	60	
STA.	TO STA.			
FED. ROAD DIST. NO.	ILLINOIS FED. AID PROJECT			

66383

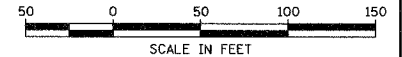

DATE	BY
DATE	BY
DATE	BY

DATE	BY
DATE	BY
DATE	BY

COMPANY NAME: #COMPANY NAME#
 PROJECT CONTACT: #PROJECT CONTACT#
 CLIENT: #CLIENT#
 ADJUTANT: #ADJUTANT#
 DATE: #DATE#

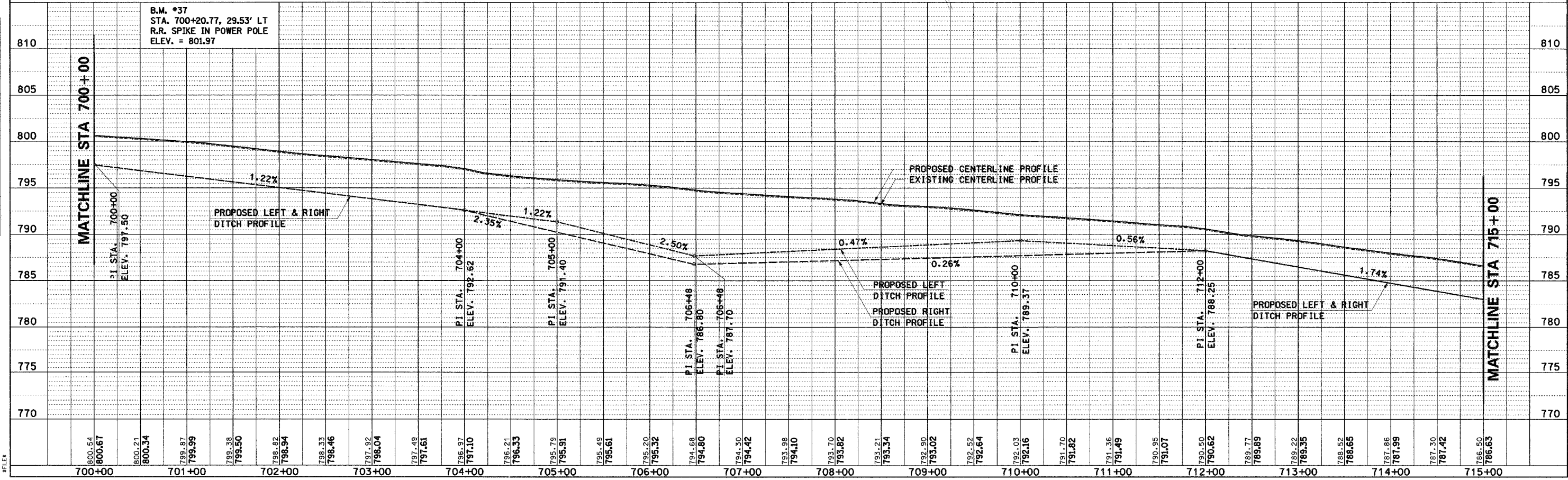
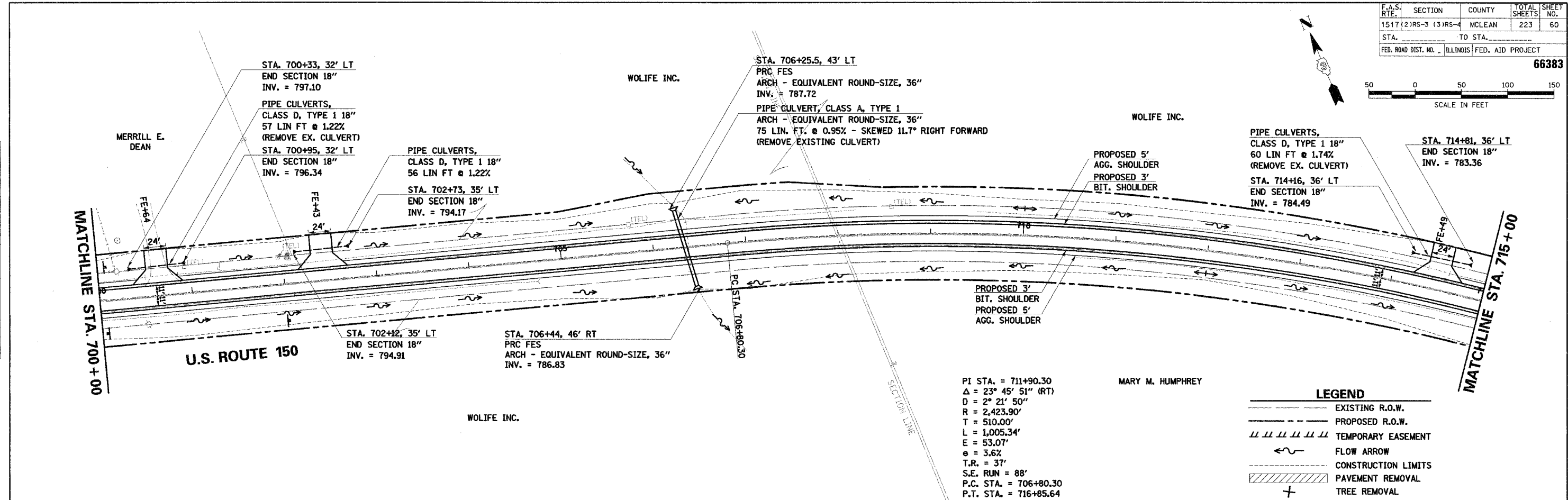

U.S. ROUTE 150 STA. 700+00 TO STA. 715+00 - PLAN AND PROFILE

F.A.S. RTLE	SECTION	COUNTY	TOTAL SHEETS	SHEET NO.
1517 (2)RS-3 (3)RS-4		MCLEAN	223	61
STA.	TO STA.			
FED. ROAD DIST. NO.	ILLINOIS FED. AID PROJECT			

66383

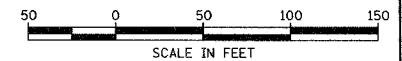

DATE	BY
DATE	BY
DATE	BY

DATE	BY
DATE	BY
DATE	BY

COMPANY NAME: COMPANY NAME
 PROJECT CONTACT: PROJECT CONTACT
 CLIENT: CLIENT
 DATE: DATE
 SHEET: SHEET

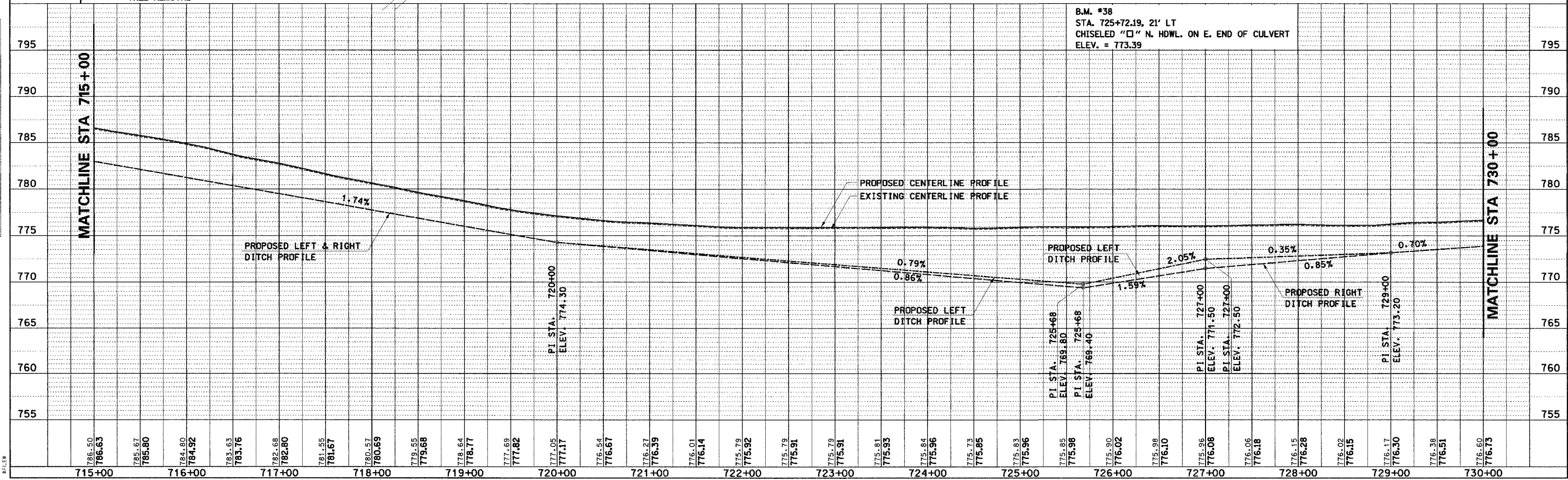
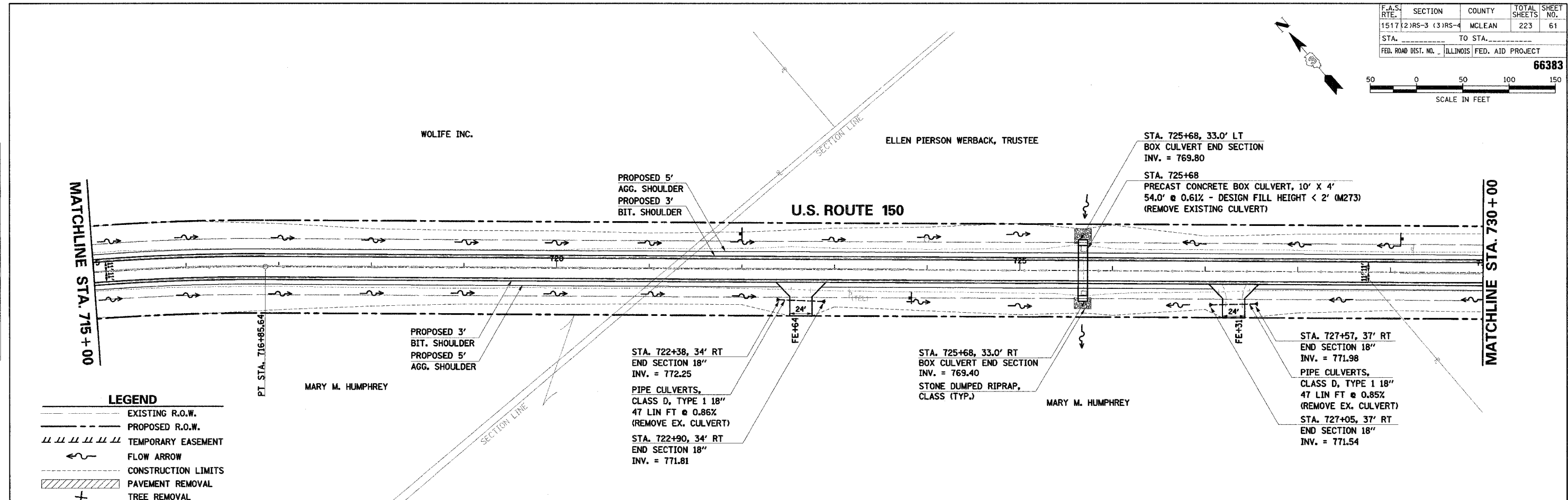

U.S. ROUTE 150 STA. 715+00 TO STA. 730+00 - PLAN AND PROFILE

F.A.S. RTE.	SECTION	COUNTY	TOTAL SHEETS	SHEET NO.
1517 (2)RS-3 (3)RS-4		MCLEAN	223	62
STA. _____ TO STA. _____				
FED. ROAD DIST. NO. _____ ILLINOIS FED. AID PROJECT				

66383

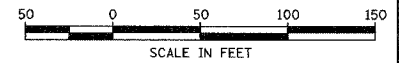

PI STA. = 741+28.96
 $\Delta = 38^\circ 03' 57''$ (LT)
 $D = 4^\circ 51' 56''$
 $R = 1,177.59'$
 $T = 406.23'$
 $L = 782.36'$
 $E = 68.10'$
 $\theta = 4.0\%$
 $T.R. = 37'$
 $S.E. RUN = 98'$
 P.C. STA. = 737+22.73
 P.T. STA. = 745+05.09

PLAN	BY	DATE
SURVEYED		
NOTE BOOK		
ALIGNED		
CHECKED		
DATE		
BY		

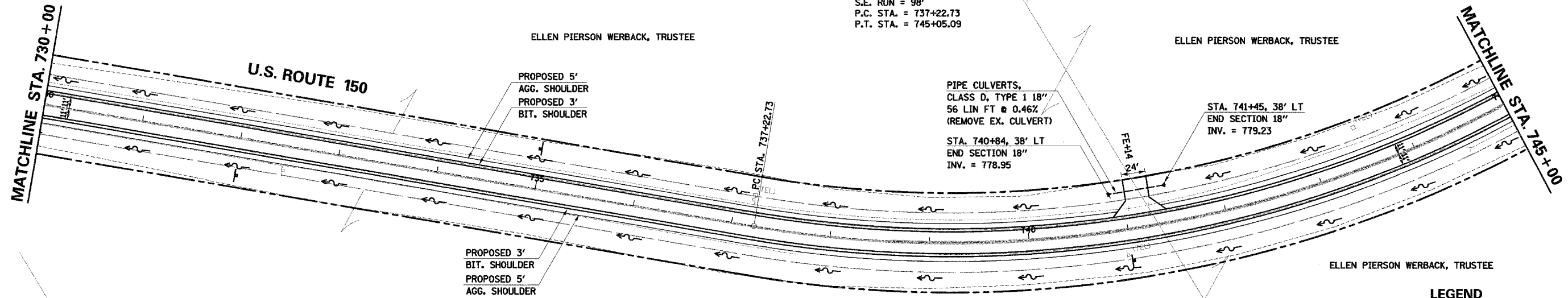

ELLEN PIERSON WERBACK, TRUSTEE

LEGEND

- EXISTING R.O.W.
- PROPOSED R.O.W.
- TEMPORARY EASEMENT
- FLOW ARROW
- CONSTRUCTION LIMITS
- PAVEMENT REMOVAL
- TREE REMOVAL

PROFILE	BY	DATE
SURVEYED		
GRADES CHECKED		
DATE		
BY		

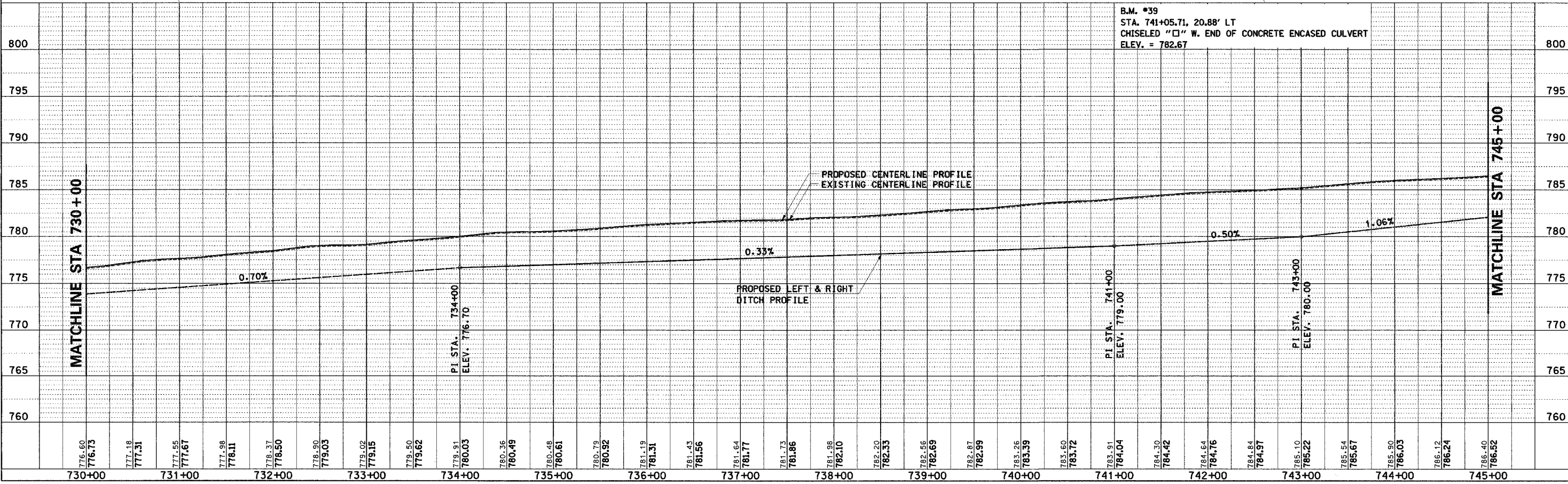

COMPANY NAME: #COMPANY NAME#
 PROJECT CONTACT: #PROJECT CONTACT#
 CLIENT: #CLIENT#
 DATE: #DATE#
 SHEET: #SHEET#

U.S. ROUTE 150 STA. 730+00 TO STA. 745+00 - PLAN AND PROFILE

F.A.S. RTE.	SECTION	COUNTY	TOTAL SHEETS	SHEET NO.
1517	(2)RS-3 (3)RS-4	MCLEAN	223	63
STA.		TO STA.		
FED. ROAD DIST. NO.		ILLINOIS FED. AID PROJECT		66383

PI STA. = 758+67.20
 $\Delta = 3^\circ 45' 35''$ (LT)
 $D = 0^\circ 27' 29''$
 $R = 12,506.77'$
 $T = 410.50'$
 $L = 820.71'$
 $E = 6.74'$
 $e = 0\%$
P.C. STA. = 754+56.69
P.T. STA. = 762+77.40

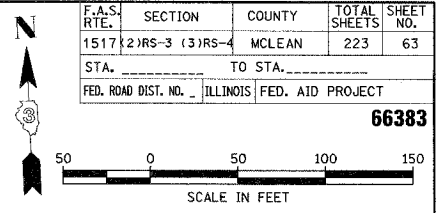

DATE	BY
DATE	BY
DATE	BY

DATE	BY
DATE	BY
DATE	BY

COMPANY NAME: COMPANY NAME
PROJECT CONTACT: PROJECT CONTACT#
CLIENT: CLIENT#
DATE: DATE#

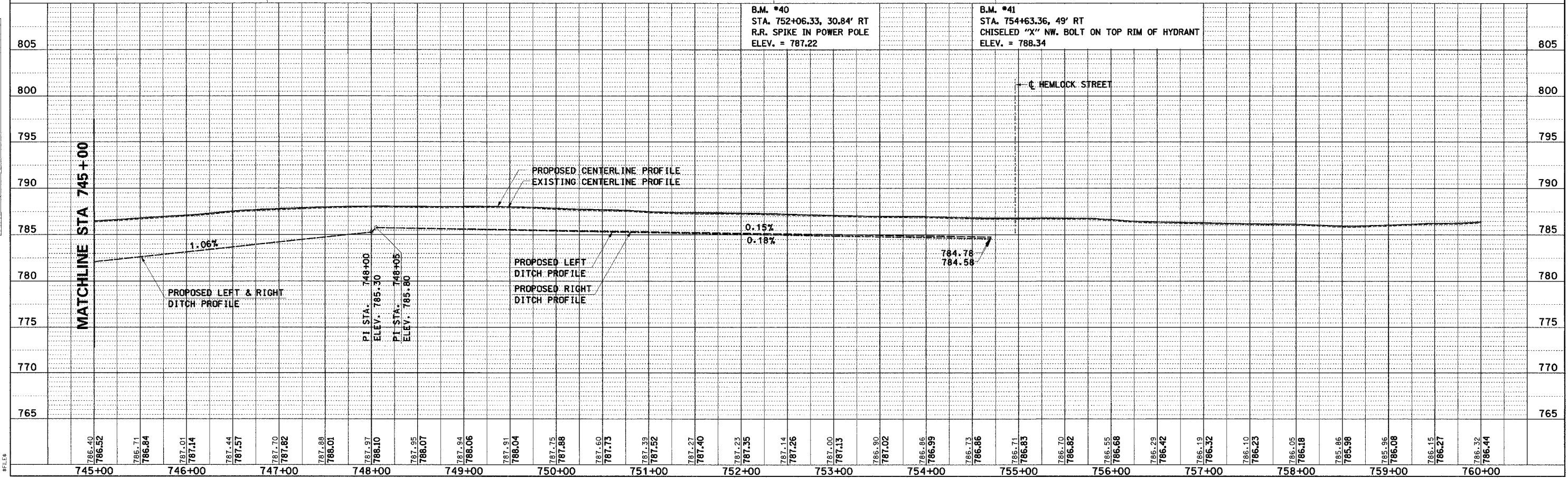
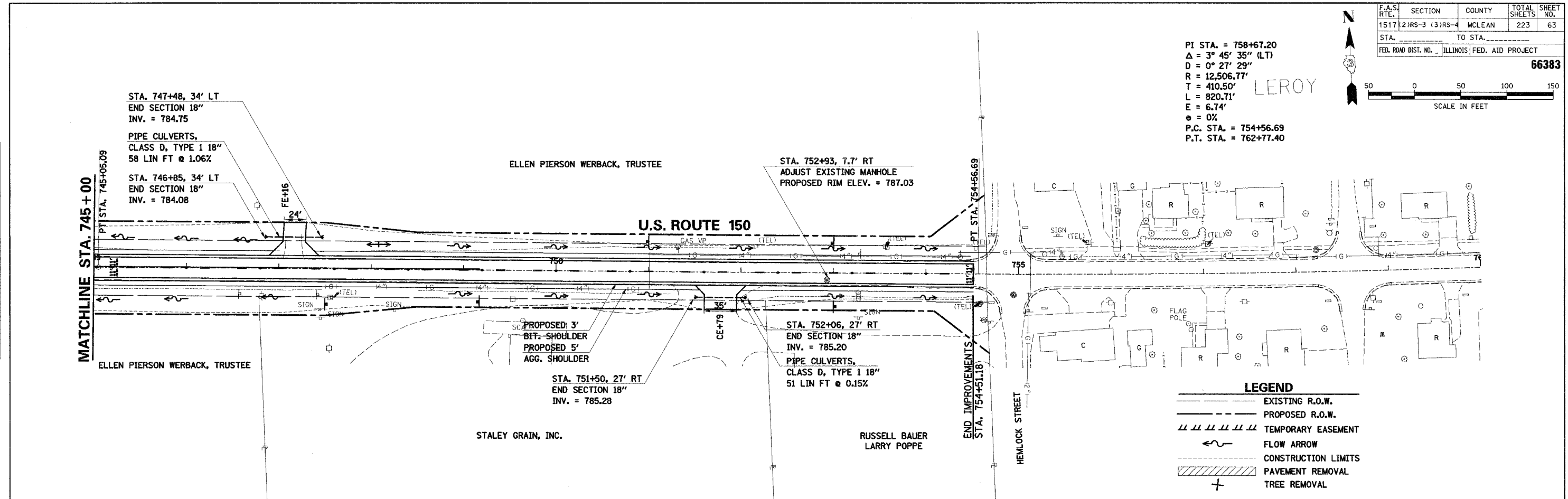

U.S. ROUTE 150 STA. 745+00 TO STA. 754+51.18 - PLAN AND PROFILE

F.A.S. RTE.	SECTION	COUNTY	TOTAL SHEETS	SHEET NO.
1517(2)RS-3	(3)RS-4	MCLEAN	223	64
STA.	TO STA.			
FED. ROAD DIST. NO.	ILLINOIS FED. AID PROJECT			

66383

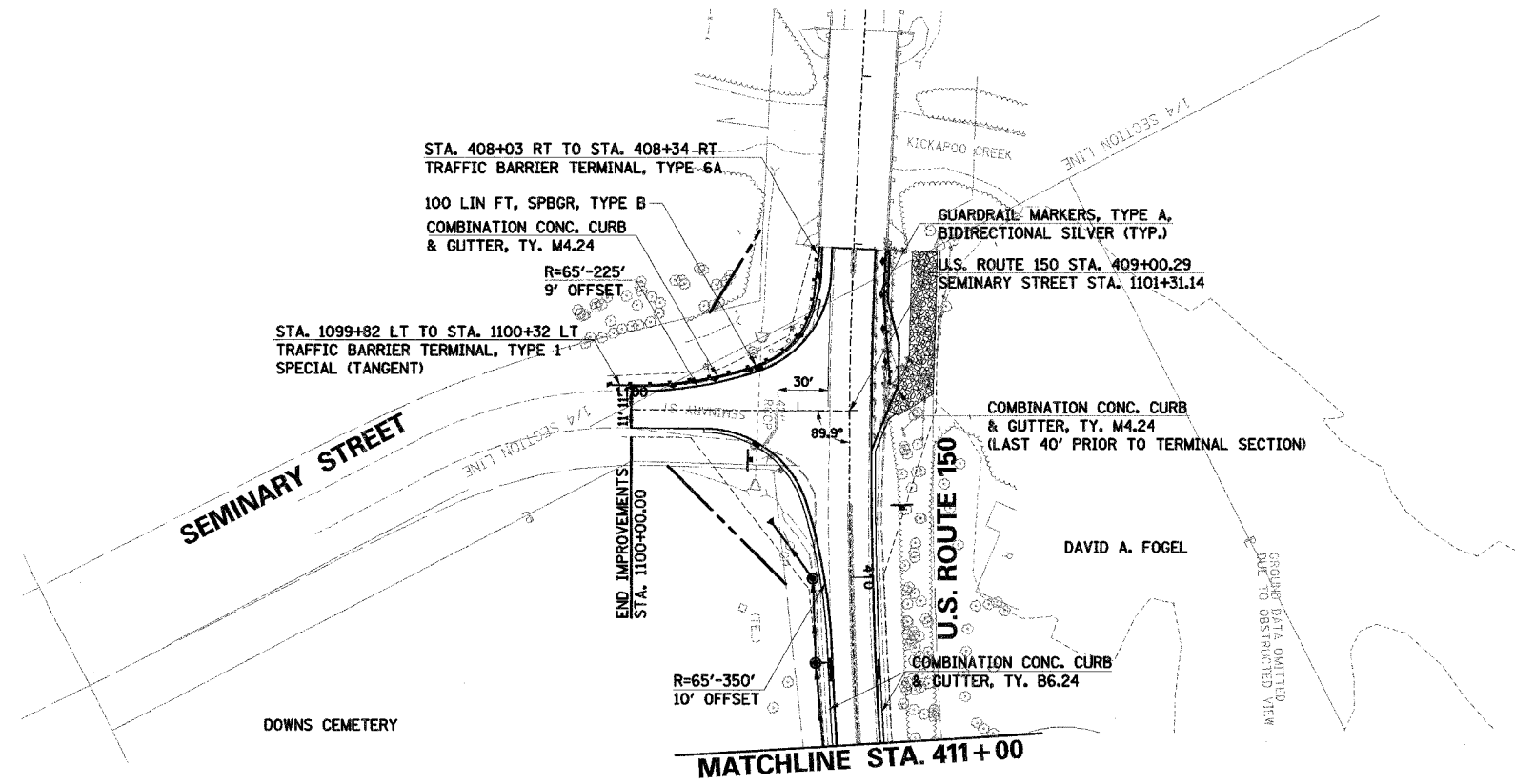
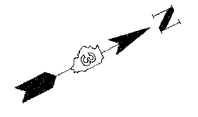
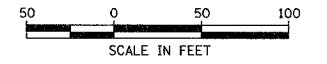

LEGEND

- EXISTING R.O.W.
- - - PROPOSED R.O.W.
- /// TEMPORARY EASEMENT
- ↔ FLOW ARROW
- - - CONSTRUCTION LIMITS
- ▨ PAVEMENT REMOVAL
- + TREE REMOVAL

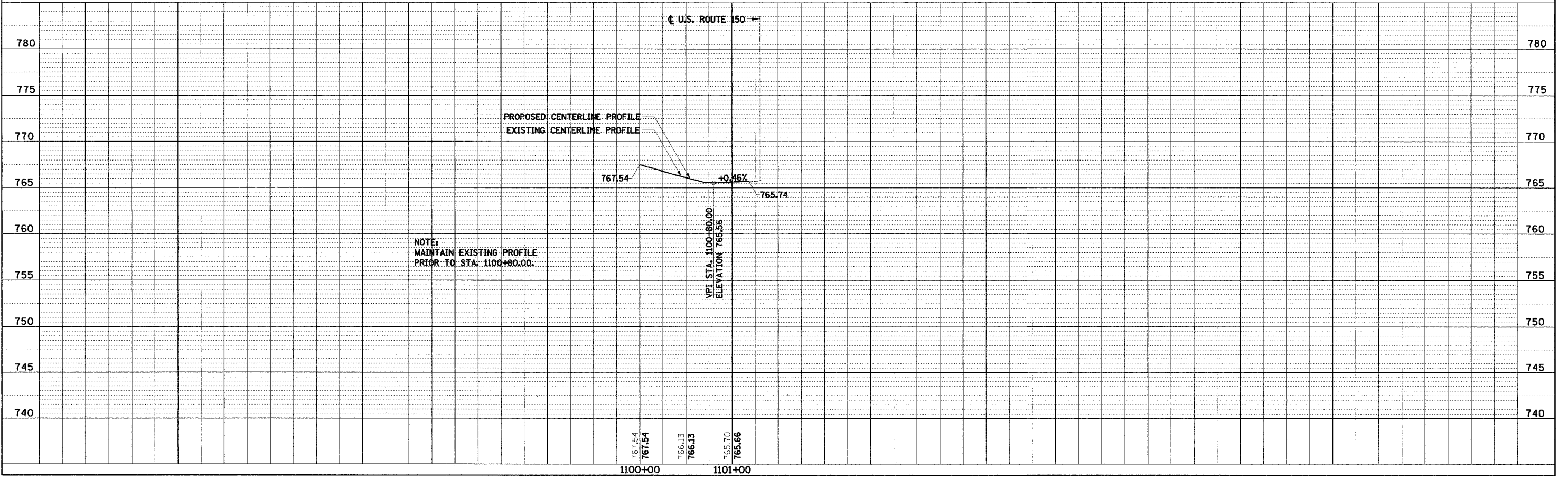

PLAN

SURVEYED	DATE
ALIGNED	
CHECKED	
BY	
NO.	

PROFILE

GRADES	DATE
CHECKED	
BY	
NO.	

COMPANY NAME: #COMPANY NAME#
 PROJECT CONTACT: #PROJECT CONTACT#
 CLIENT: #CLIENT#
 #DATE#
 #FILES#

SEMINARY STREET STA. 1100+00 TO STA. 1101+31.14 - PLAN AND PROFILE

F.A.S. RTE.	SECTION	COUNTY	TOTAL SHEETS	SHEET NO.
1517	2/RS-3 (3)RS-4	MCLEAN	223	65
STA. _____ TO STA. _____				
FED. ROAD DIST. NO. _____ ILLINOIS FED. AID PROJECT				

66383

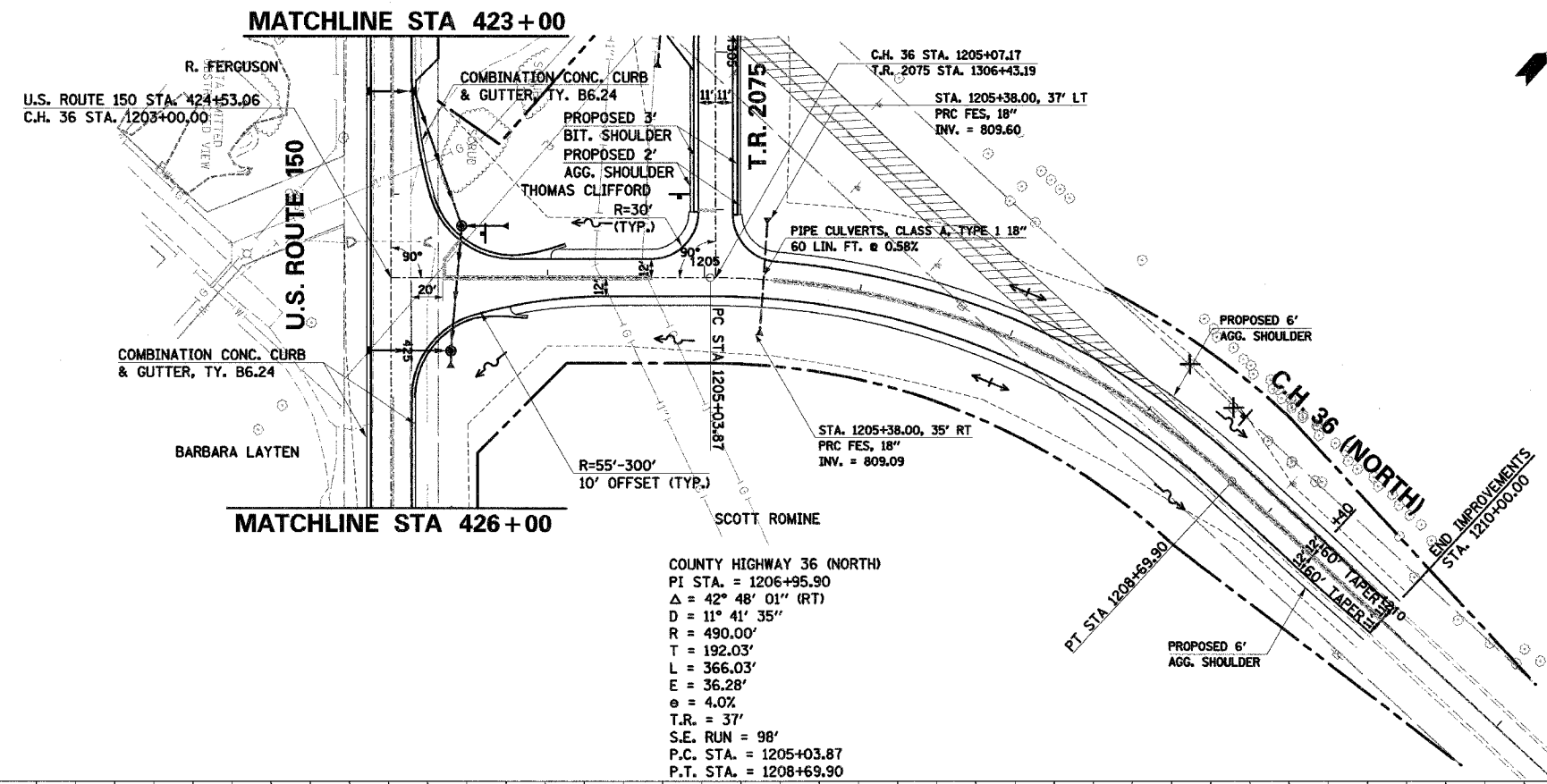
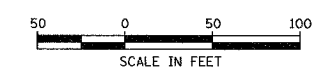

COUNTY HIGHWAY 36 (NORTH)
 PI STA. = 1206+95.90
 $\Delta = 42^\circ 48' 01''$ (RT)
 D = $11^\circ 41' 35''$
 R = 490.00'
 T = 192.03'
 L = 366.03'
 E = 36.28'
 $e = 4.0\%$
 T.R. = 37'
 S.E. RUN = 98'
 P.C. STA. = 1205+03.87
 P.T. STA. = 1208+69.90

LEGEND

	EXISTING R.O.W.
	PROPOSED R.O.W.
	TEMPORARY EASEMENT
	FLOW ARROW
	CONSTRUCTION LIMITS
	PAVEMENT REMOVAL
	TREE REMOVAL

DATE _____ BY _____

PLANNING

DESIGNED BY _____

CHECKED BY _____

DATE _____

DATE _____ BY _____

PROFILE

DESIGNED BY _____

CHECKED BY _____

DATE _____

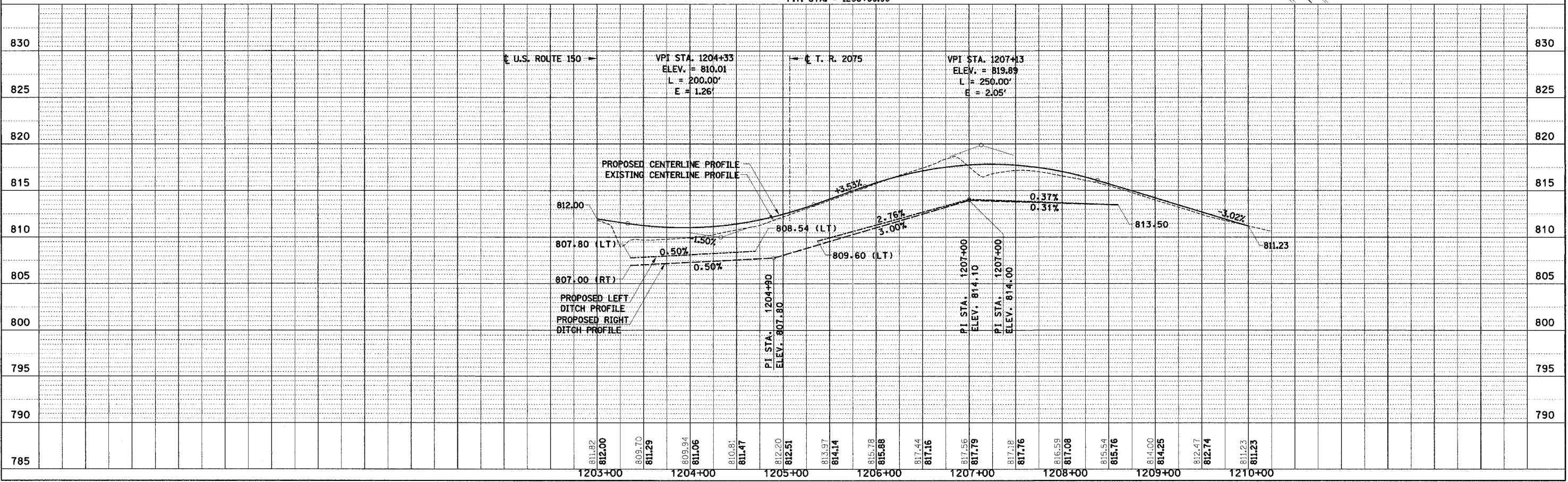

COMPANY NAME: _____

PROJECT CONTACT: _____

CLIENT: _____

DATE: _____

C.H. 36 (NORTH) STA. 1203+00 TO STA. 1210+00 - PLAN AND PROFILE

F.A.S. RTE.	SECTION	COUNTY	TOTAL SHEETS	SHEET NO.
1517	2)RS-3 (3)RS-4	MCLEAN	223	66
STA. _____ TO STA. _____				
FED. ROAD DIST. NO. _____ ILLINOIS FED. AID PROJECT				

66383

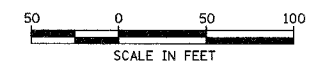

DATE	BY	SURVEYED	ALIGNED	CHECKED	PLANNED	DESIGNED	NOTED	REVISIONS	DATE	BY

DATE	BY	SURVEYS	GRADES	CHECKED	PLANNED	DESIGNED	NOTED	REVISIONS	DATE	BY

COMPANY NAME: #COMPANY NAME #
 PROJECT CONTACT: #PROJECT CONTACT #
 CLIENT: #CLIENT #
 DATE: #DATE #
 BY: #BY #

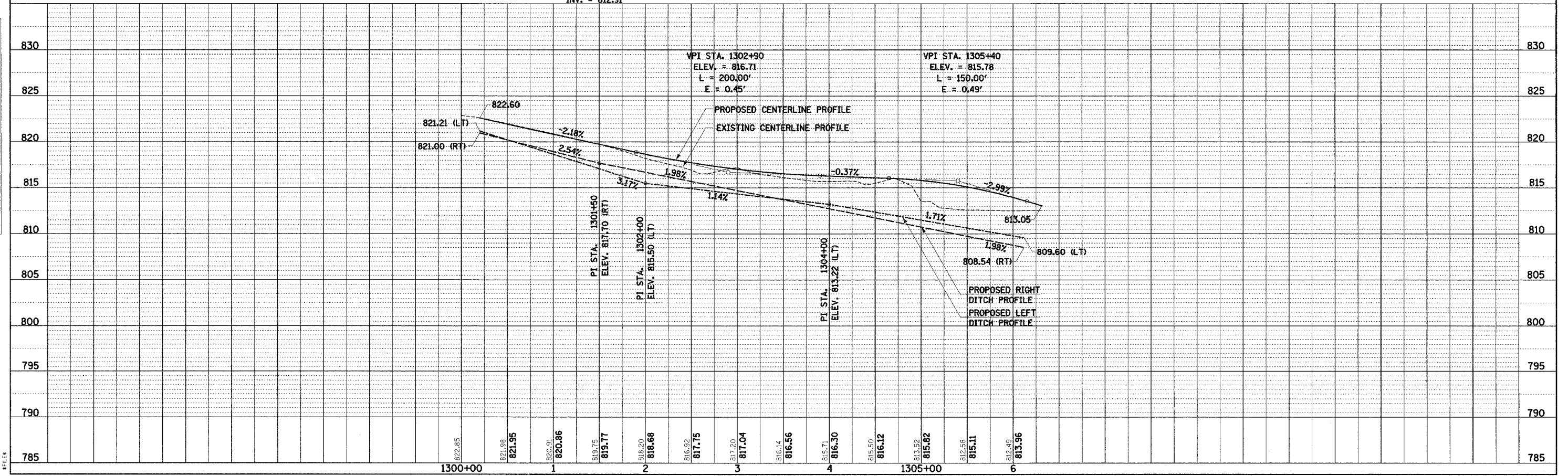
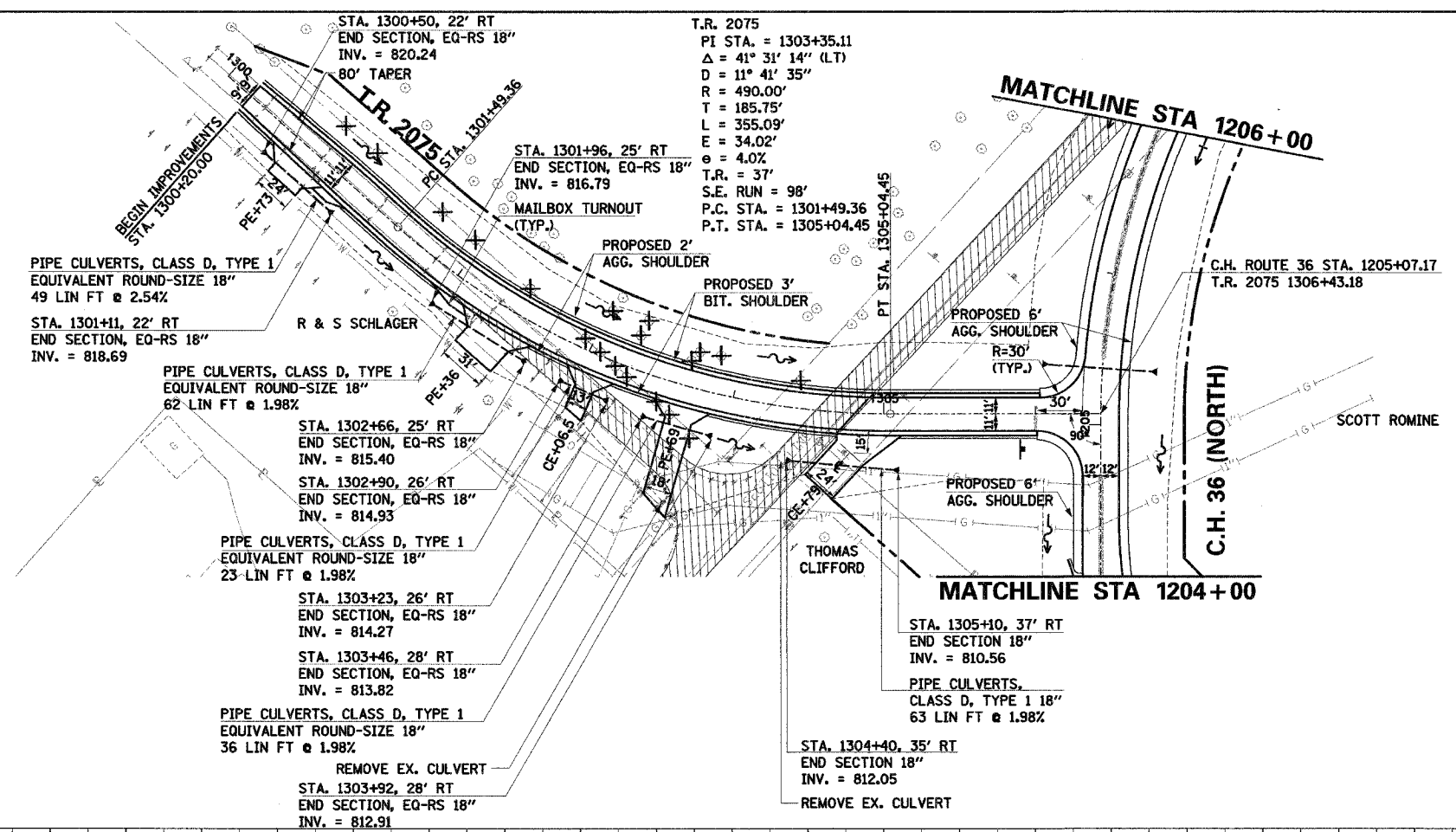

T.R. 2075 STA. 1300+20 TO STA. 1306+43.19 - PLAN AND PROFILE

F.A.S. RTE.	SECTION	COUNTY	TOTAL SHEETS	SHEET NO.
1517 (2)RS-3 (3)RS-4		MCLEAN	223	67
STA.	TO STA.			
FED. ROAD DIST. NO. - ILLINOIS FED. AID PROJECT				

66383

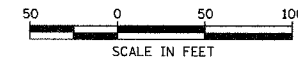

DATE	BY	REVISION

DATE	BY	REVISION

COMPANY NAME: #COMPANY/NAME#
 PROJECT CONTACT: #PROJECT_CONTACT#
 CLIENT: #CLIENT#
 #DATE# #TIME#
 #PL#

WASHINGTON STREET
 PI STA. = 1502+00.64
 $\Delta = 43^\circ 26' 26''$ (LT)
 $D = 114^\circ 35' 30''$
 $R = 50.00'$
 $T = 19.92'$
 $L = 37.91'$
 $E = 3.82'$
 $\theta =$
 $T.R. =$
 $S.E. RUN =$
 $P.C. STA. = 1501+80.72$
 $P.T. STA. = 1502+18.63$

COMBINATION CONC. CURB
 & GUTTER, TYPE B6.24

NOTE:
 AREA BEHIND CURB IN THE NORTHWEST CORNER OF THE
 WASHINGTON STREET INTERSECTION SHALL BE GRADED
 TO ENSURE DRAINAGE TOWARDS THE INLET LOCATED AT
 U.S. ROUTE 150 STA. 437+00, 22.5' RT.

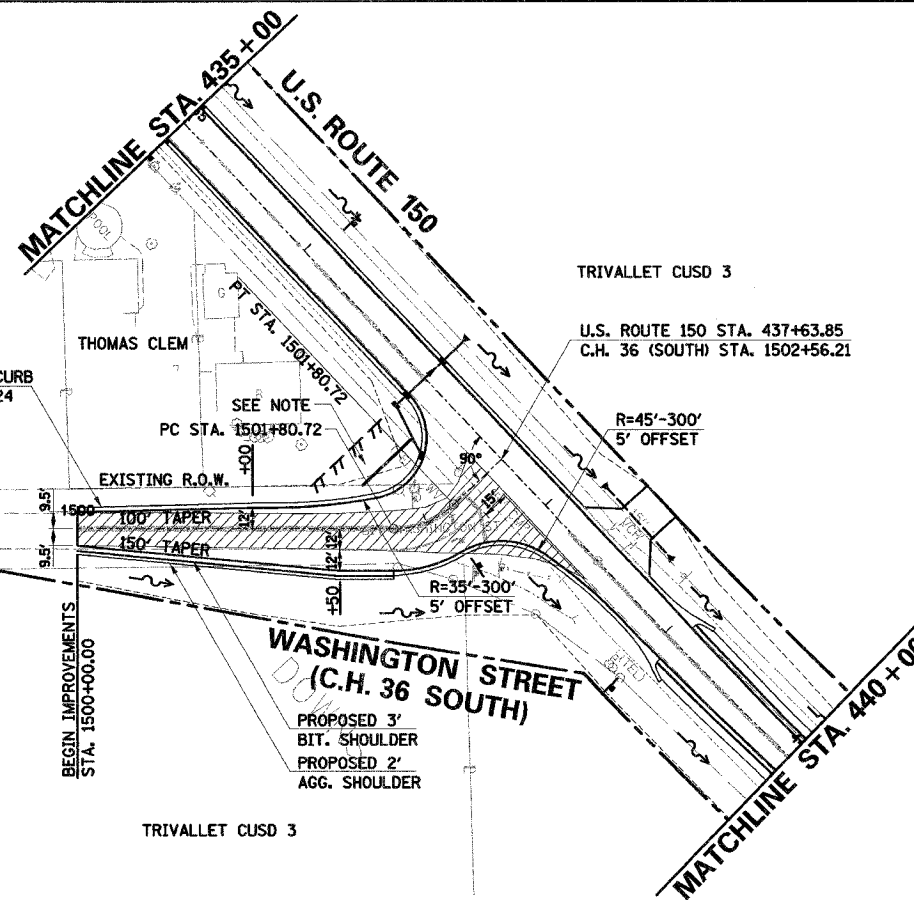

LEGEND

	EXISTING R.O.W.
	PROPOSED R.O.W.
	TEMPORARY EASEMENT
	FLOW ARROW
	CONSTRUCTION LIMITS
	PAVEMENT REMOVAL
	TREE REMOVAL

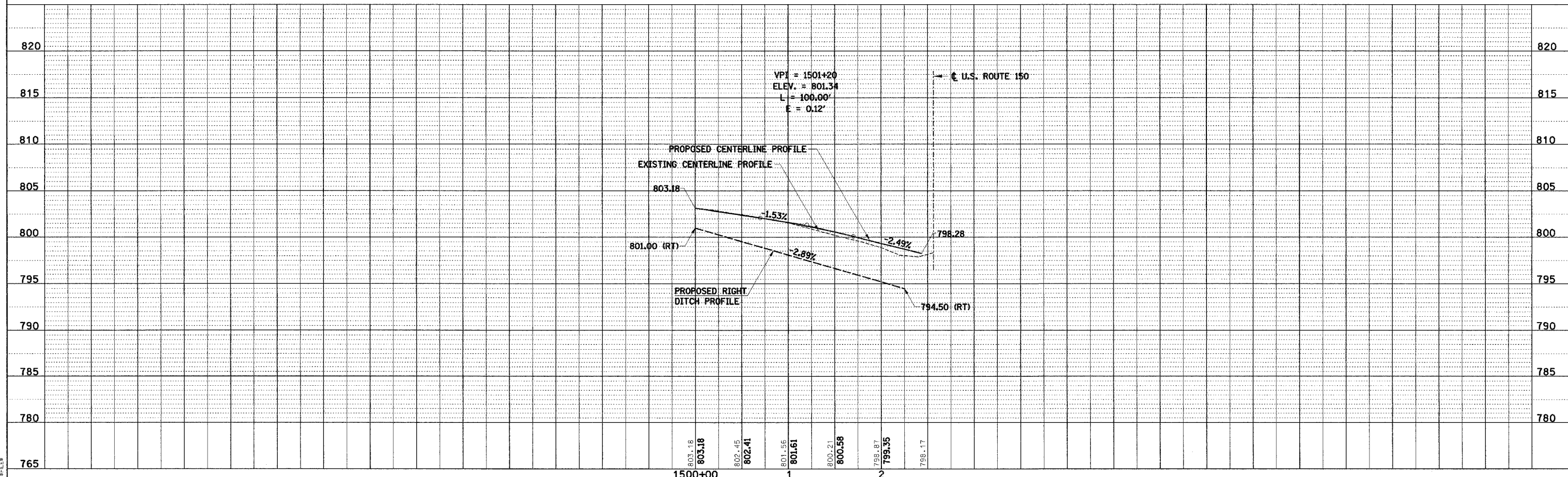

WASHINGTON STREET (C.H. 36 SOUTH) STA. 1500+00 TO STA. 1502+56.21 - PLAN AND PROFILE

F.A.S. RTE.	SECTION	COUNTY	TOTAL SHEETS	SHEET NO.
1517(2)RS-3 (3)RS-4		MCLEAN	223	68
STA. _____ TO STA. _____		ILLINOIS FED. AID PROJECT		

66383

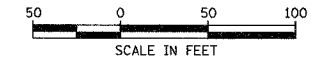

PLAN	BY	DATE
SURVEYED		
NOTE BOOK		
ALIGNED		
CHECKED		
DATE		

PROFILE	BY	DATE
SURVEYED		
NOTE BOOK		
GRADES CHECKED		
DATE		

COMPANY NAME: #COMPANY NAME#
 PROJECT CONTACT: #PROJECT CONTACT#
 CLIENT: #CLIENT#
 DATE: #DATE#
 SHEET: #SHEET#

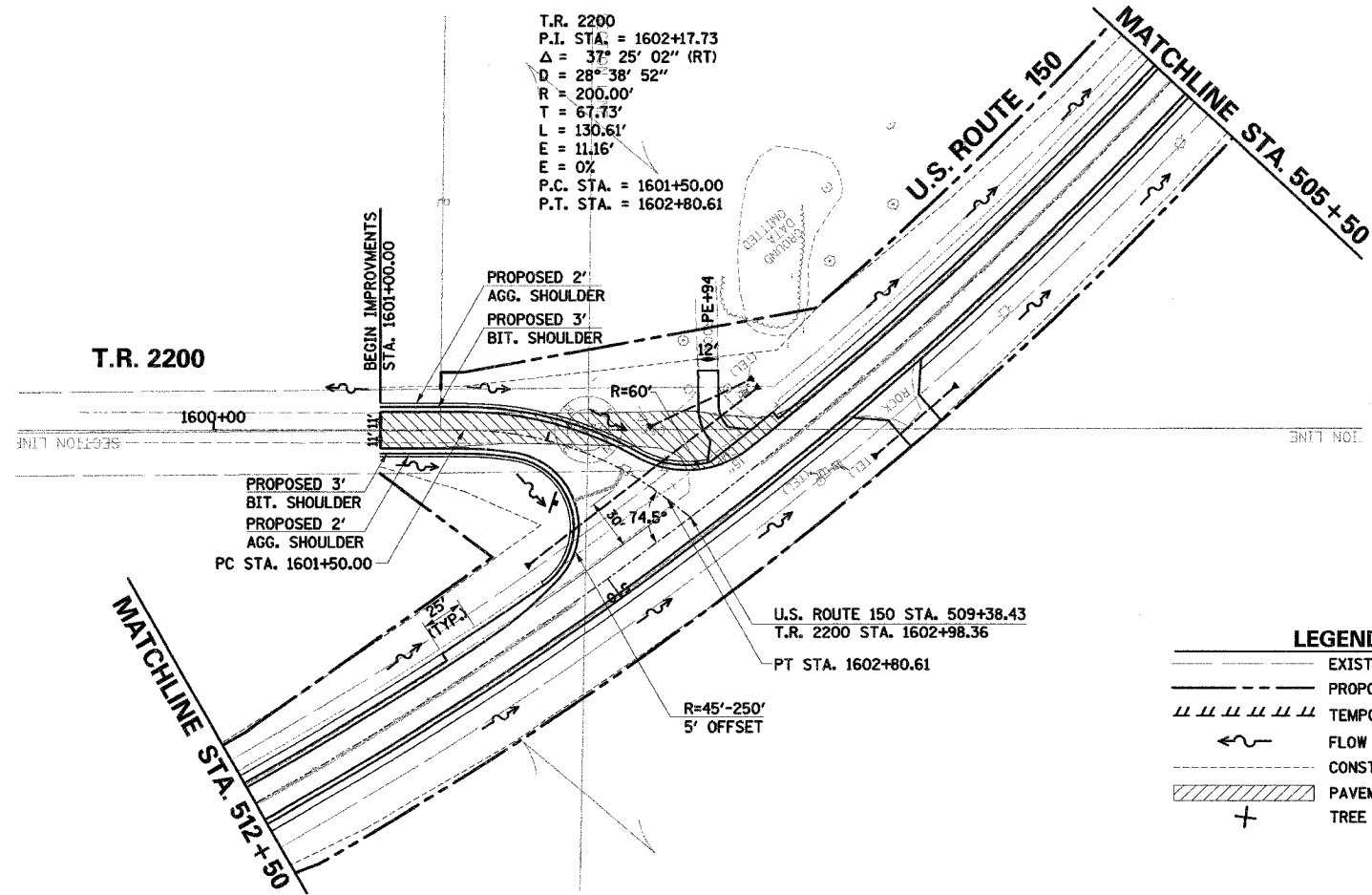

LEGEND

- EXISTING R.O.W.
- - - PROPOSED R.O.W.
- /// TEMPORARY EASEMENT
- ~ FLOW ARROW
- - - CONSTRUCTION LIMITS
- /// PAVEMENT REMOVAL
- + TREE REMOVAL

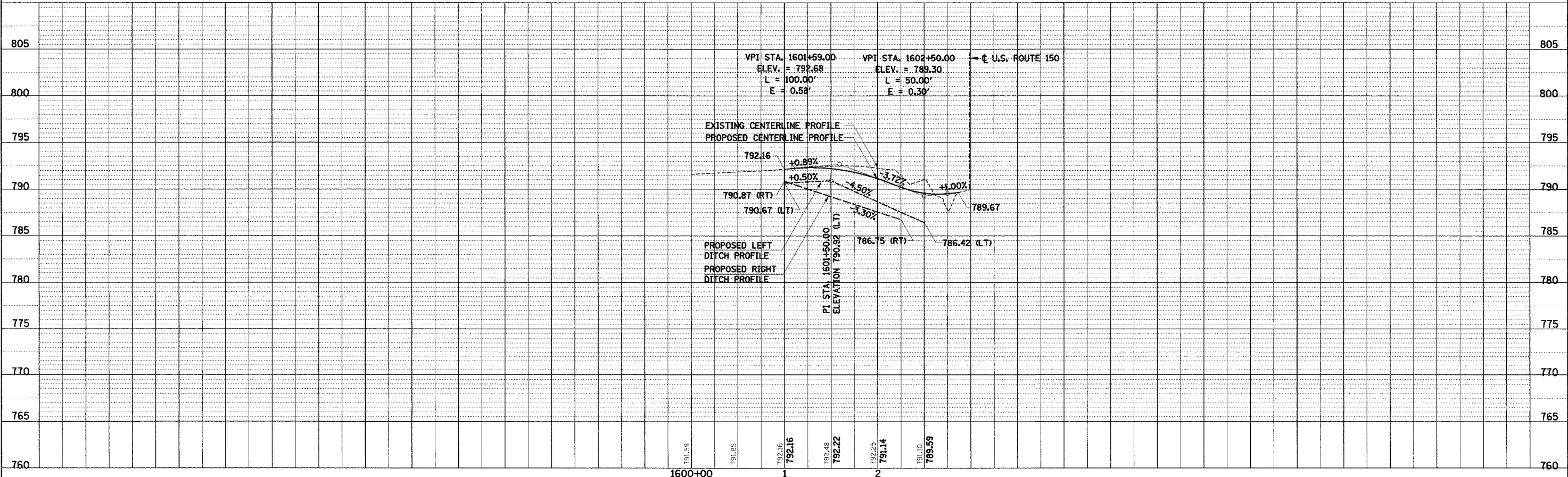

T.R. 2200 STA. 1601+00 TO STA. 1602+98.36 - PLAN AND PROFILE

F.A.S. RTE.	SECTION	COUNTY	TOTAL SHEETS	SHEET NO.
1517 (2)RS-3 (3)RS-4		MCLEAN	223	69
STA.	TO STA.			
FED. ROAD DIST. NO.	ILLINOIS		FED. AID PROJECT	

66383

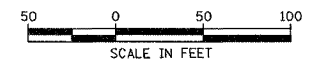

DATE	BY
DATE	BY

DATE	BY
DATE	BY

COMPANY NAME # COMPANY NAME #
 PROJECT CONTACT # PROJECT CONTACT #
 CLIENT # CLIENT #
 DATE # DATE #
 SHEET # SHEET #

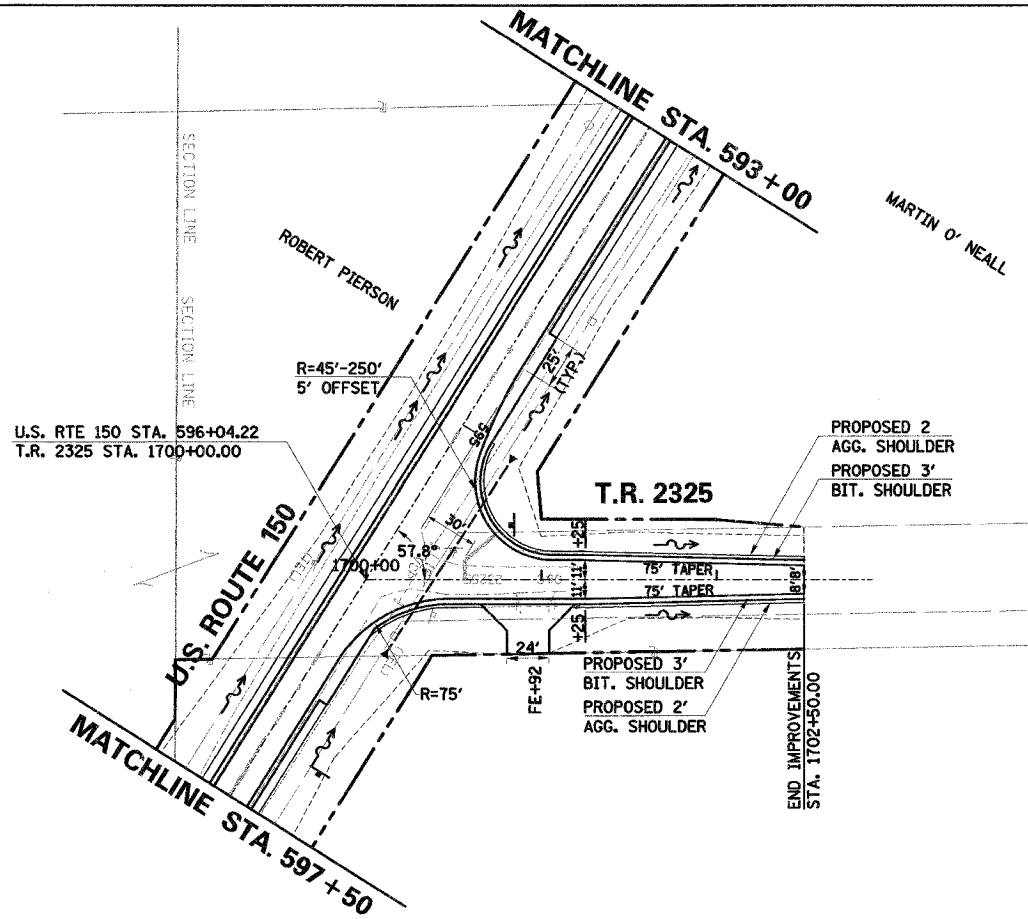

LEGEND	
	EXISTING R.O.W.
	PROPOSED R.O.W.
	TEMPORARY EASEMENT
	FLOW ARROW
	CONSTRUCTION LIMITS
	PAVEMENT REMOVAL
	TREE REMOVAL

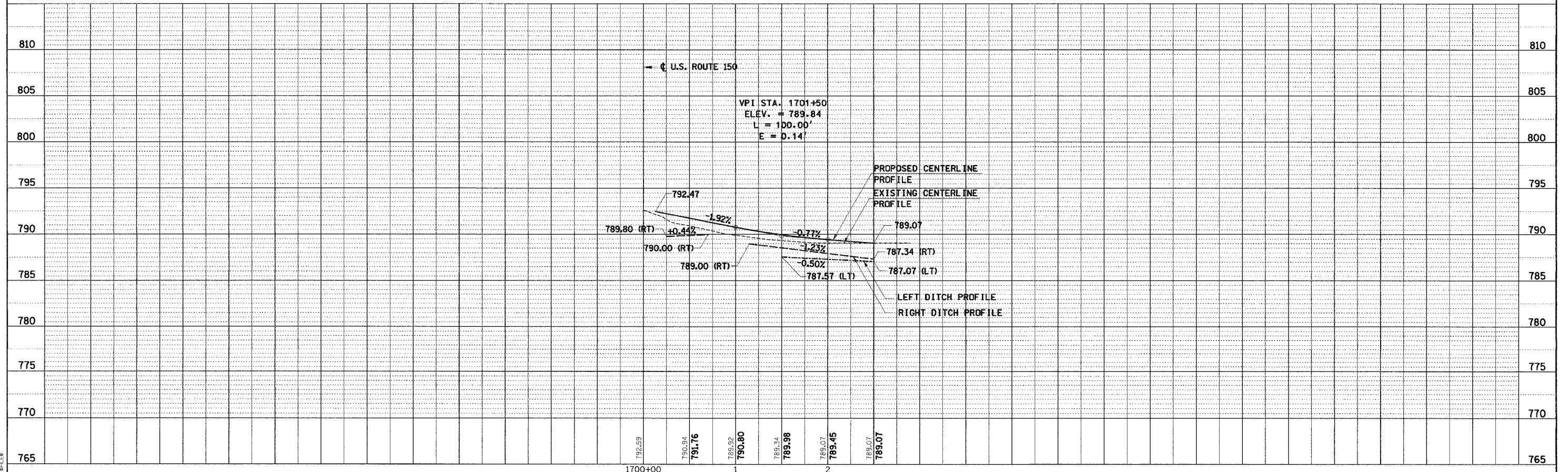

T.R. 2325 STA. 1700+00 TO STA. 1702+50 - PLAN AND PROFILE

F.A.S. RTE.	SECTION	COUNTY	TOTAL SHEETS	SHEET NO.
1517 (2)RS-3 (3)RS-4		MCLEAN	223	70
STA.	TO STA.			
FED. ROAD DIST. NO.	ILLINOIS FED. AID PROJECT			

66383

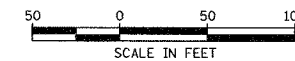

PLAN	SURVEYED	DATE
NOTE BOOK	ALIGNED	
NO.	CHECKED	
	BY	
	DATE	

PROFILE	SURVEYED	DATE
NOTE BOOK	GRADES CHECKED	
NO.	BY	
	DATE	

COMPANY NAME: #COMPANY/NAME#
 PROJECT CONTACT: #PROJECT/CONTACT#
 CLIENT: #CLIENT/F#
 #DITES #TIMEN
 #LES

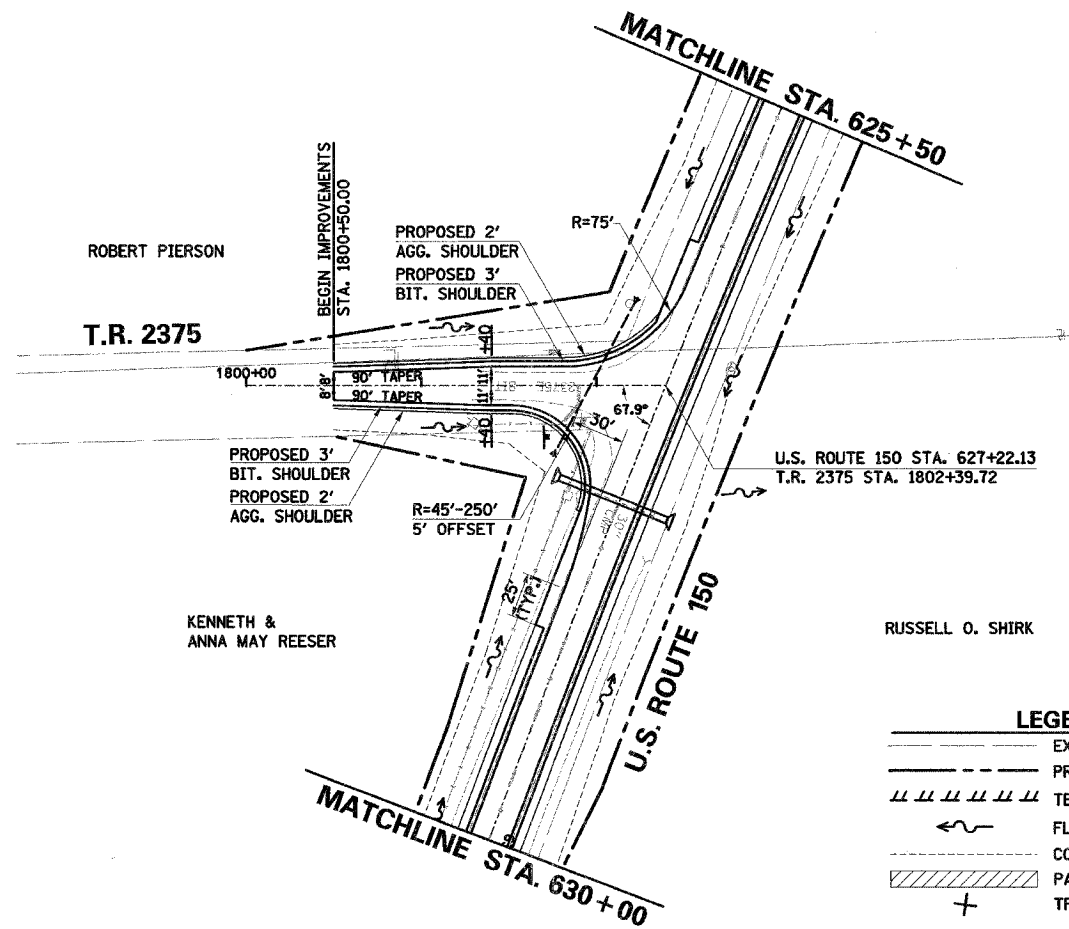

LEGEND

- EXISTING R.O.W.
- PROPOSED R.O.W.
- TEMPORARY EASEMENT
- FLOW ARROW
- CONSTRUCTION LIMITS
- PAVEMENT REMOVAL
- TREE REMOVAL

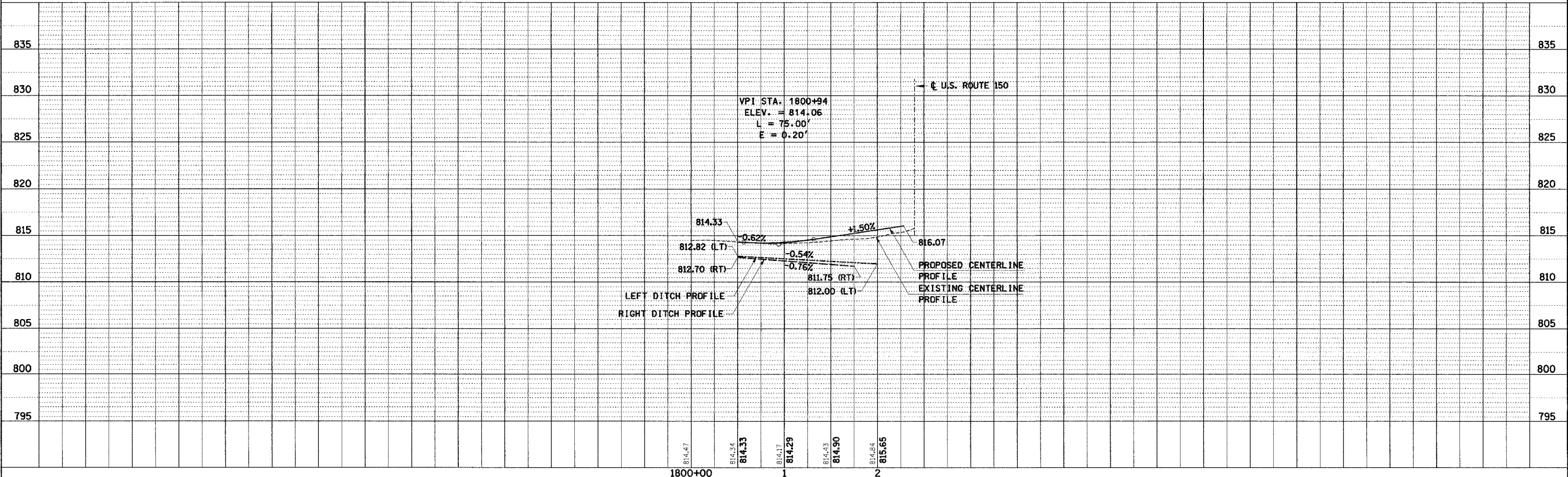

F.A.S. RTE.	SECTION	COUNTY	TOTAL SHEETS	SHEET NO.
1517 (2)RS-3 (3)RS-4	MCLEAN	223	71	
STA.	TO STA.			
FED. ROAD DIST. NO.	ILLINOIS	FED. AID PROJECT		

66383

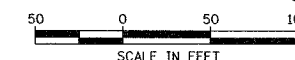

DATE	BY	SURVEYED	CHECKED
		ALIGNED	CHECKED
		PLANNED	CHECKED
		DESIGNED	CHECKED
		CONSTRUCTED	CHECKED
		MAINTAINED	CHECKED
		REMOVED	CHECKED
		REINSTALLED	CHECKED
		REPAIRED	CHECKED
		REPLACED	CHECKED
		REMOVED	CHECKED
		REINSTALLED	CHECKED
		REPAIRED	CHECKED
		REPLACED	CHECKED

DATE	BY	SURVEYED	CHECKED
		ALIGNED	CHECKED
		PLANNED	CHECKED
		DESIGNED	CHECKED
		CONSTRUCTED	CHECKED
		MAINTAINED	CHECKED
		REMOVED	CHECKED
		REINSTALLED	CHECKED
		REPAIRED	CHECKED
		REPLACED	CHECKED

COMPANY NAME: #COMPANY NAME#
 PROJECT CONTACT: #PROJECT CONTACT#
 CLIENT: #CLIENT#
 DATE: #DATE#
 FILE#

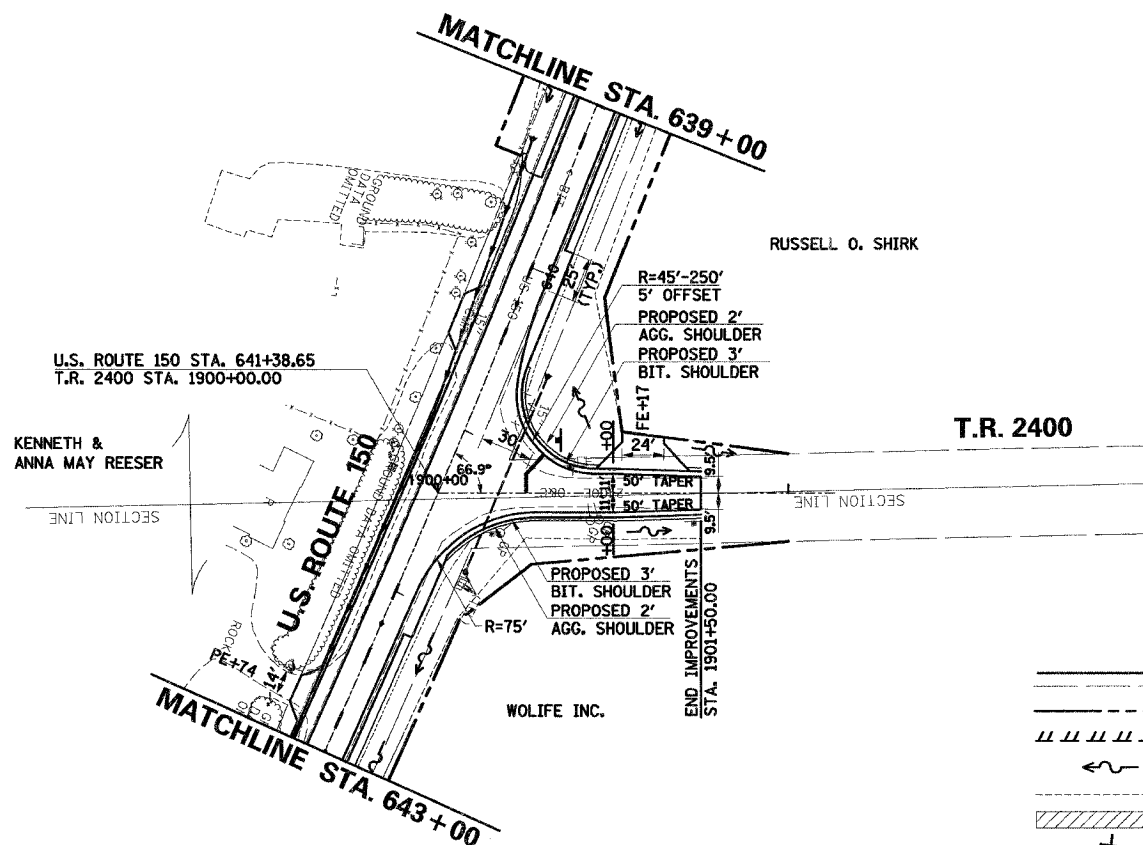

LEGEND

	EXISTING R.O.W.
	PROPOSED R.O.W.
	TEMPORARY EASEMENT
	FLOW ARROW
	CONSTRUCTION LIMITS
	PAVEMENT REMOVAL
	TREE REMOVAL

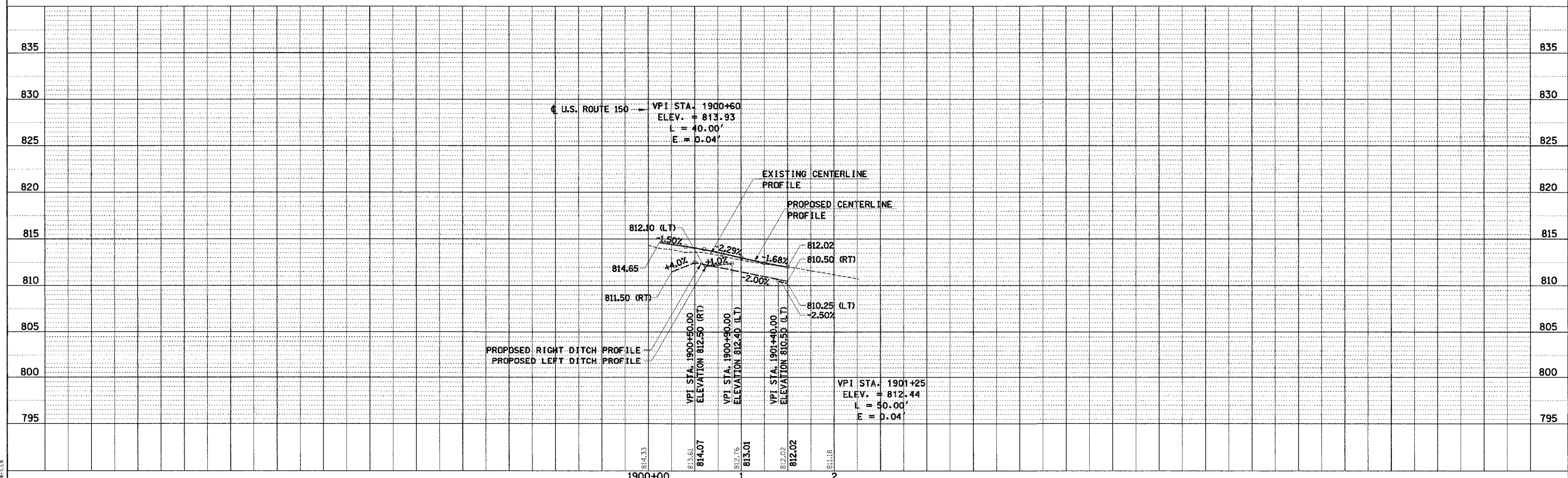

F.A.S. RTE.	SECTION	COUNTY	TOTAL SHEETS	SHEET NO.
1517	27RS-3 (3)RS-4	MCLEAN	223	72
STA.	TO STA.			
FED. ROAD DIST. NO. ILLINOIS FED. AID PROJECT				

66383

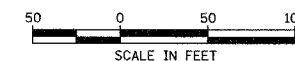

DATE	BY
SURVEYED	CHECKED
ALIGNED	CHECKED
PLANNED	CHECKED
NOTE BOOK NO.	ADD. FILE NAME

DATE	BY
PROFILING	CHECKED
GRADES	CHECKED
PLAN	NOTED
NOTE BOOK NO.	ENCLOSURE NOTATIONS (SRFD)

COMPANY NAME: COMPANY NAME
 PROJECT CONTACT: PROJECT CONTACT
 CLIENT: CLIENT
 DATE: DATE
 BY: BY

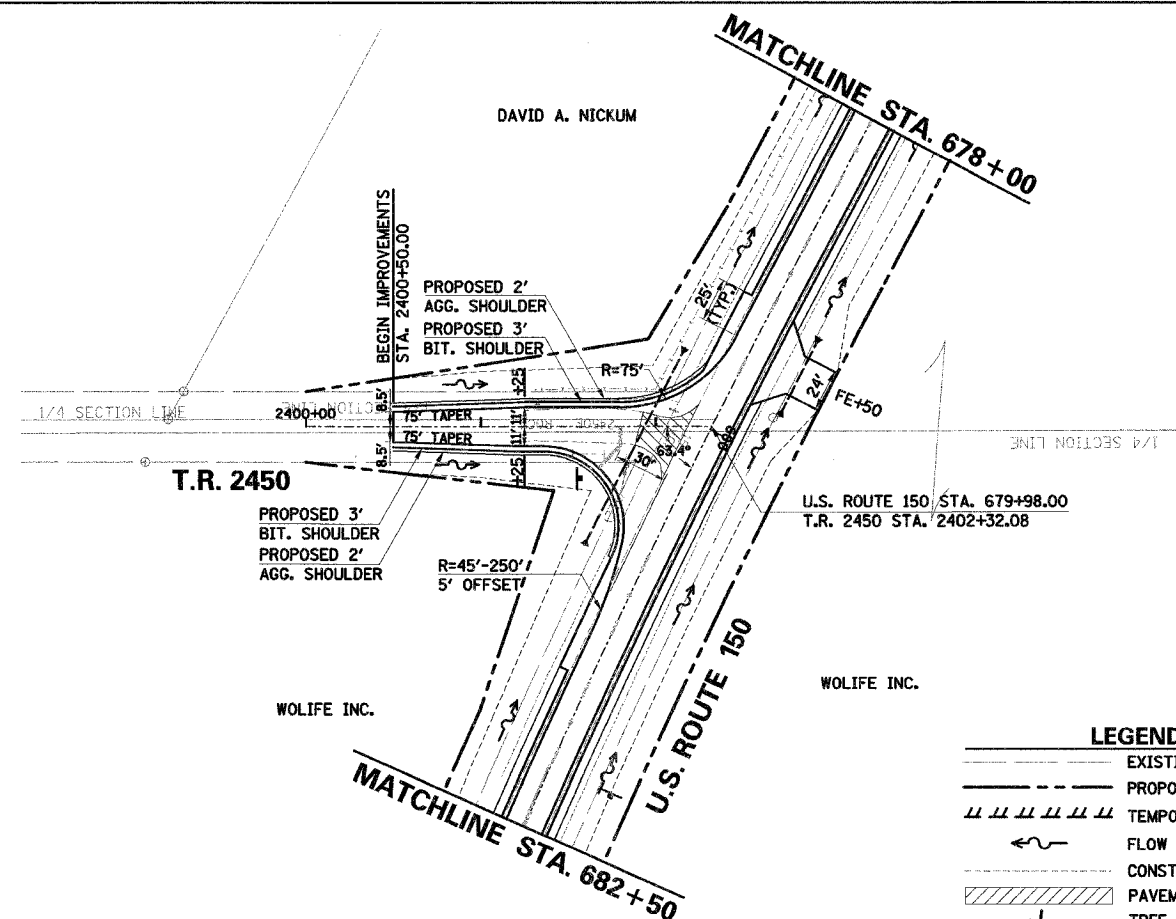

LEGEND

	EXISTING R.O.W.
	PROPOSED R.O.W.
	TEMPORARY EASEMENT
	FLOW ARROW
	CONSTRUCTION LIMITS
	PAVEMENT REMOVAL
	TREE REMOVAL

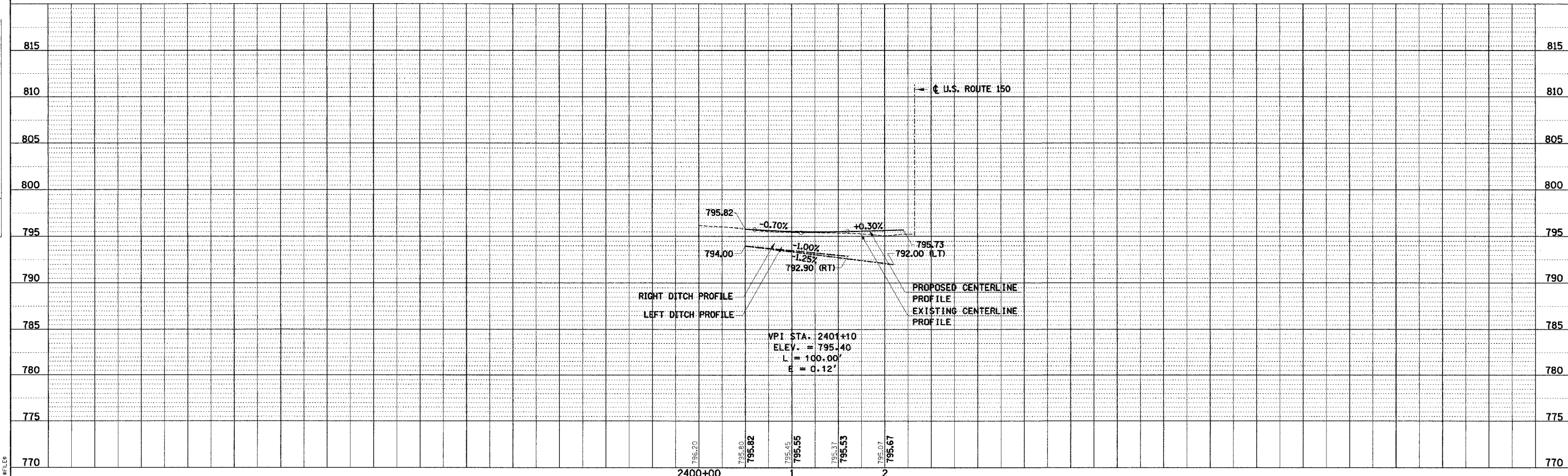

T.R. 2450 STA. 2400+49 TO STA. 2402+32.08 - PLAN AND PROFILE

F.A.S. R/L	SECTION	COUNTY	TOTAL SHEETS	SHEET NO.
1517 (2)RS-3 (3)RS-4		MCLEAN	223	73
STA. _____ TO STA. _____				
FED. ROAD DIST. NO. - ILLINOIS FED. AID PROJECT				

66383

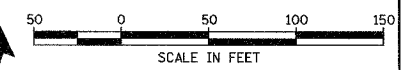

DATE	BY
DATE	BY

DATE	BY
DATE	BY

COMPANY NAME: #COMPANY NAME#
 PROJECT CONTACT: #PROJECT CONTACT#
 CLIENT: #CLIENT#
 #DATE# #TIME#
 #FILE#

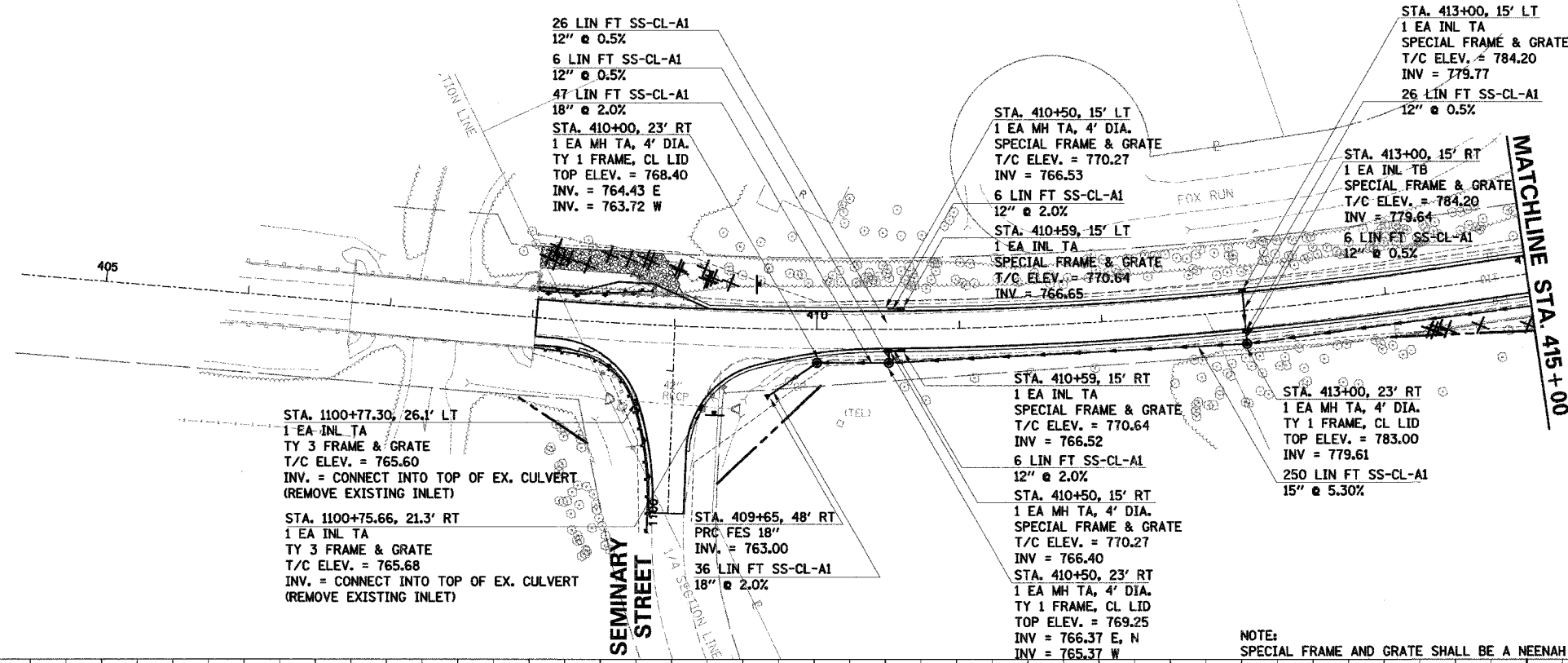

NOTE:
SPECIAL FRAME AND GRATE SHALL BE A NEENAH R-3222-LA OR EQUIVALENT.

LEGEND

- EXISTING R.O.W.
- PROPOSED R.O.W.
- TEMPORARY EASEMENT
- FLOW ARROW
- CONSTRUCTION LIMITS

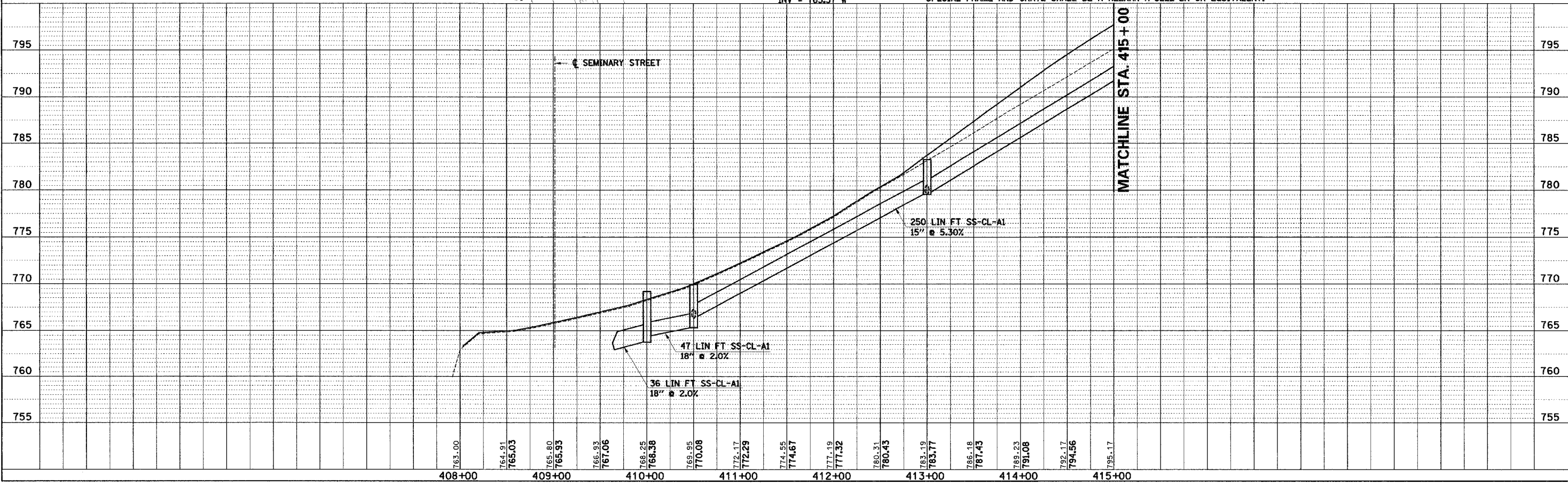

U.S. ROUTE 150 STA. 408+02.77 TO STA. 415+00 - DRAINAGE PLAN AND PROFILE

F.A.S. RTE.	SECTION	COUNTY	TOTAL SHEETS	SHEET NO.
1517 (2)RS-3 (3)RS-4		MCLEAN	223	74
STA.	TO STA.			
FED. ROAD DIST. NO.	ILLINOIS FED. AID PROJECT			

66383

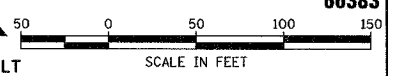

DATE	BY
DATE	BY

DATE	BY
DATE	BY

COMPANY NAME: #COMPANY NAME#
 PROJECT CONTACT: #PROJECT CONTACT#
 CLIENT: #CLIENT#
 DATES: #DATES#
 FILES: #FILES#

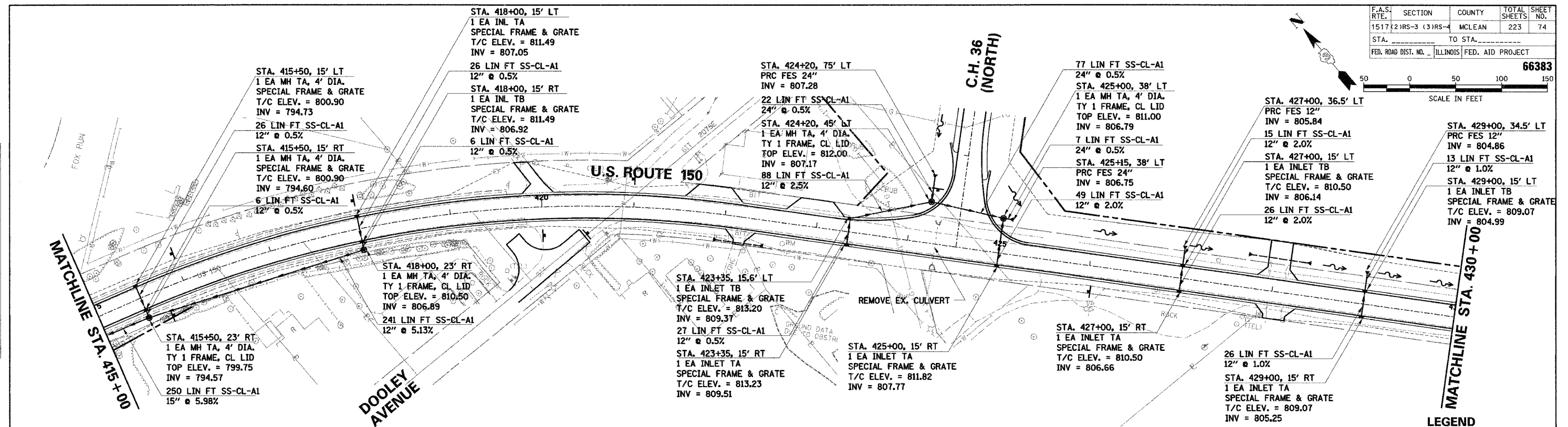

NOTE:
 SPECIAL FRAME AND GRATE SHALL BE A NEENAH R-3222-LA OR EQUIVALENT.

LEGEND

- EXISTING R.O.W.
- - - PROPOSED R.O.W.
- /// TEMPORARY EASEMENT
- FLOW ARROW
- - - CONSTRUCTION LIMITS

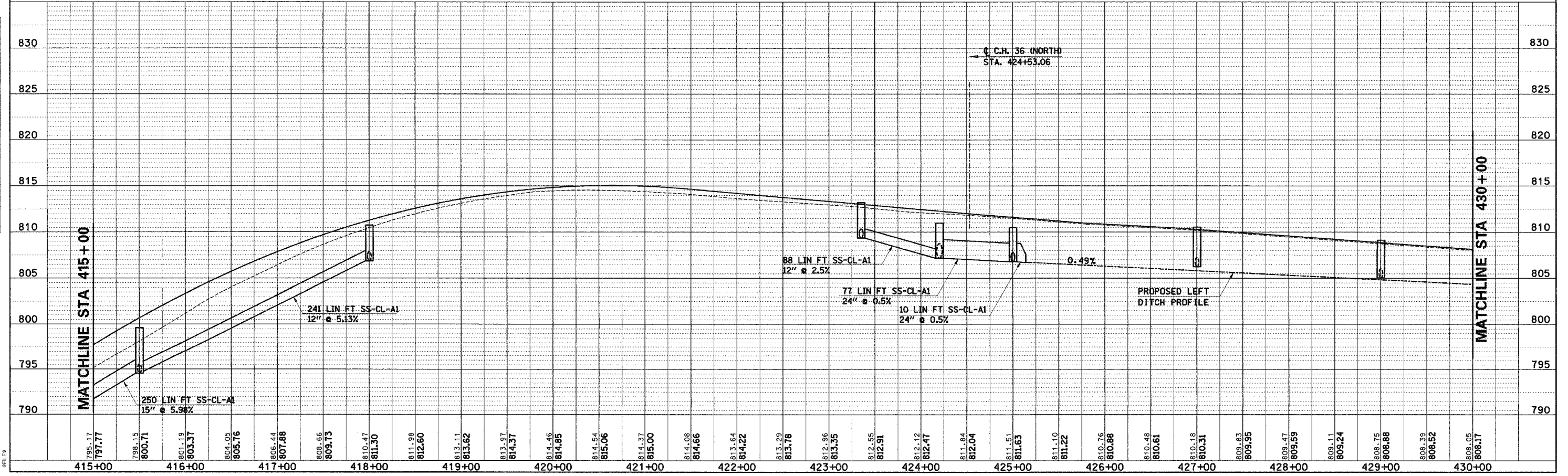

U.S. ROUTE 150 STA. 415+00 TO STA. 430+00 - DRAINAGE PLAN AND PROFILE

F.A.S. RTE.	SECTION	COUNTY	TOTAL SHEETS	SHEET NO.
1517 (2)RS-3 (3)RS-4		MCLEAN	223	75
STA.	TO STA.			
FED. ROAD DIST. NO.	ILLINOIS FED. AID PROJECT			

66383

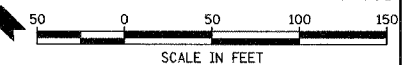

PLAN	DATE
NO.	
BY	
CHECKED	
APPROVED	
PROJECT NAME	

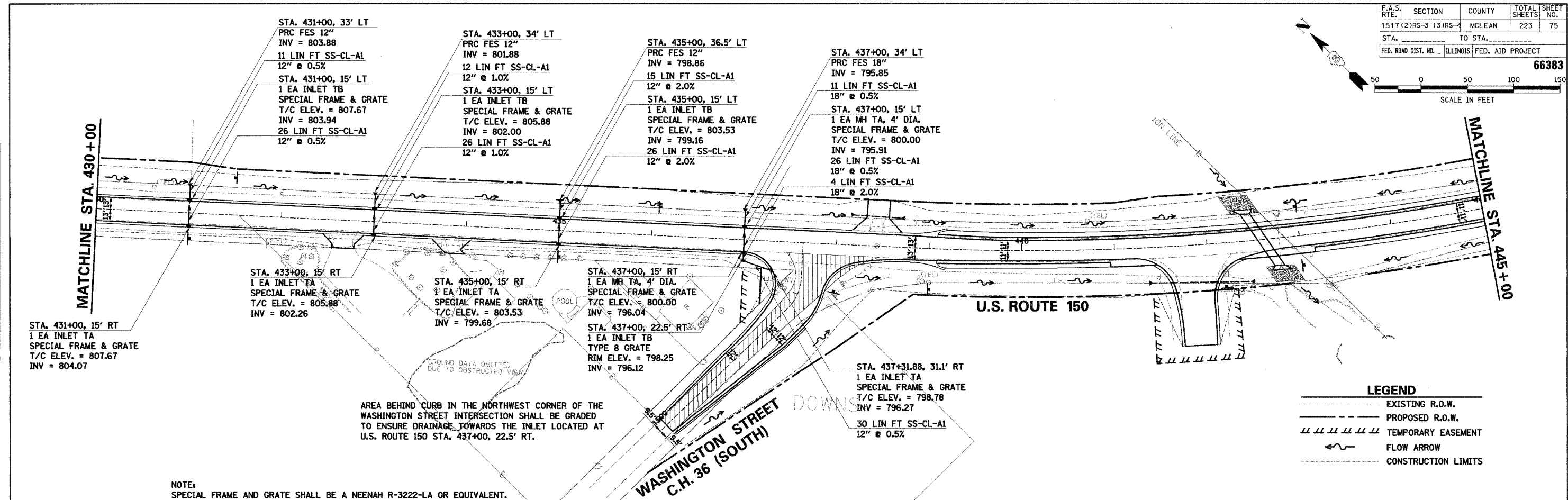

LEGEND

- EXISTING R.O.W.
- PROPOSED R.O.W.
- TEMPORARY EASEMENT
- FLOW ARROW
- CONSTRUCTION LIMITS

PROFILE	DATE
NO.	
BY	
CHECKED	
APPROVED	
PROJECT NAME	

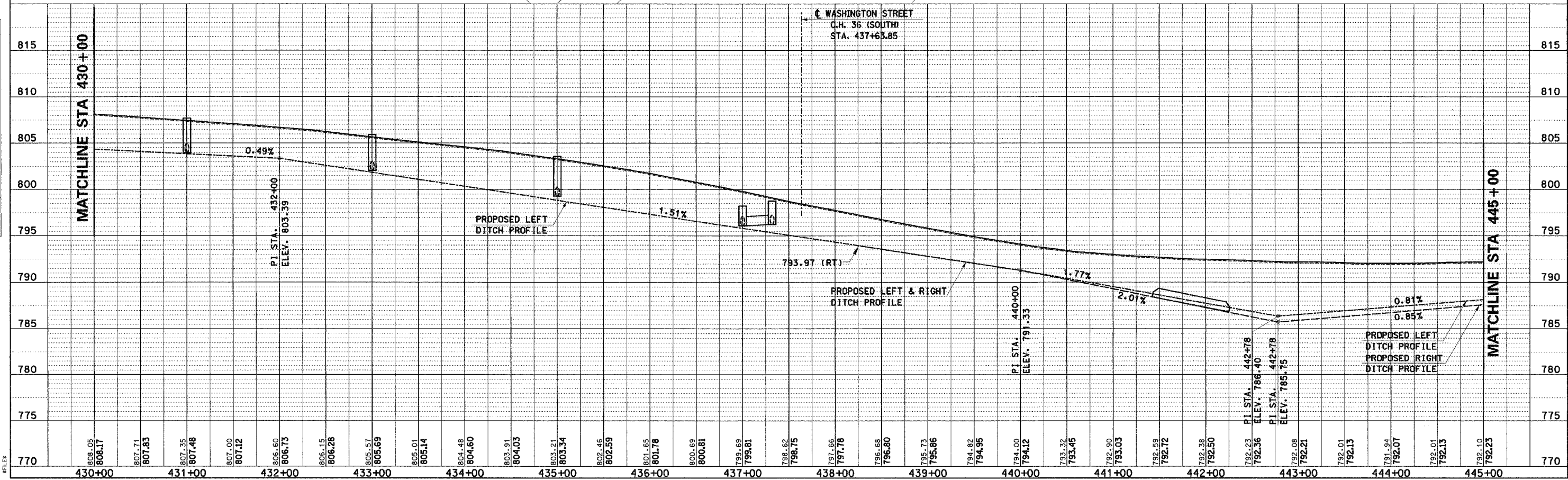

U.S. ROUTE 150 STA. 430+00 TO STA. 445+00 - DRAINAGE PLAN AND PROFILE

COMPANY NAME: #COMPANY NAME#
PROJECT CONTACT: #PROJECT CONTACT#
CLIENT: #CLIENT#
DATE: #DATE#
ELEV: #ELEV#

F.A.S. RTE.	SECTION	COUNTY	TOTAL SHEETS	SHEET NO.
1517	(2)RS-3 (3)RS-4	MCLEAN	223	76
STA. _____ TO STA. _____		ILLINOIS FED. AID PROJECT		

66383

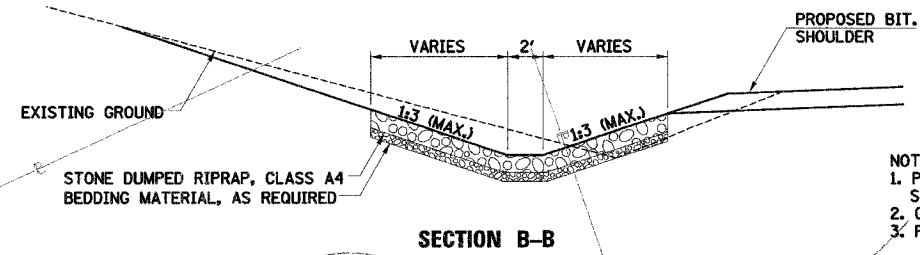
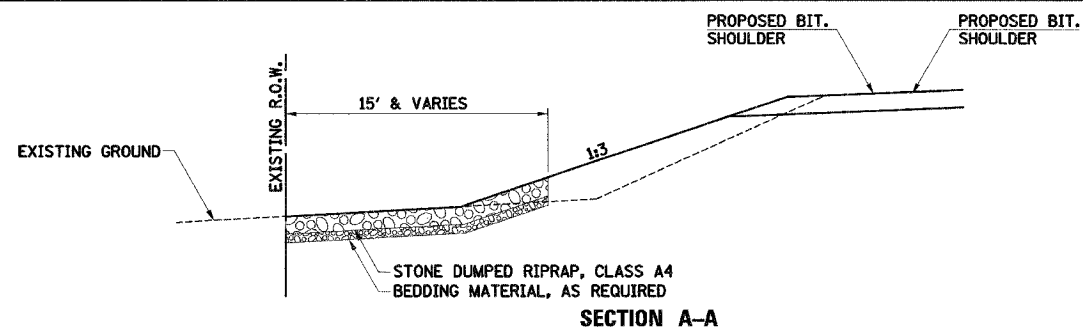
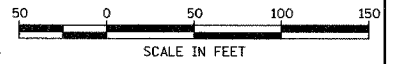

- NOTES (STONE DUMPED RIPRAP):
1. PRIOR TO FINAL RIPRAP PLACEMENT, AREA SHALL BE GRADED TO THE SATISFACTION OF THE ENGINEER.
 2. GRADING SHALL NOT RESULT IN SLOPES EXCEEDING 1:3.
 3. FINAL RIPRAP PLACEMENT SUBJECT TO THE APPROVAL OF THE ENGINEER.

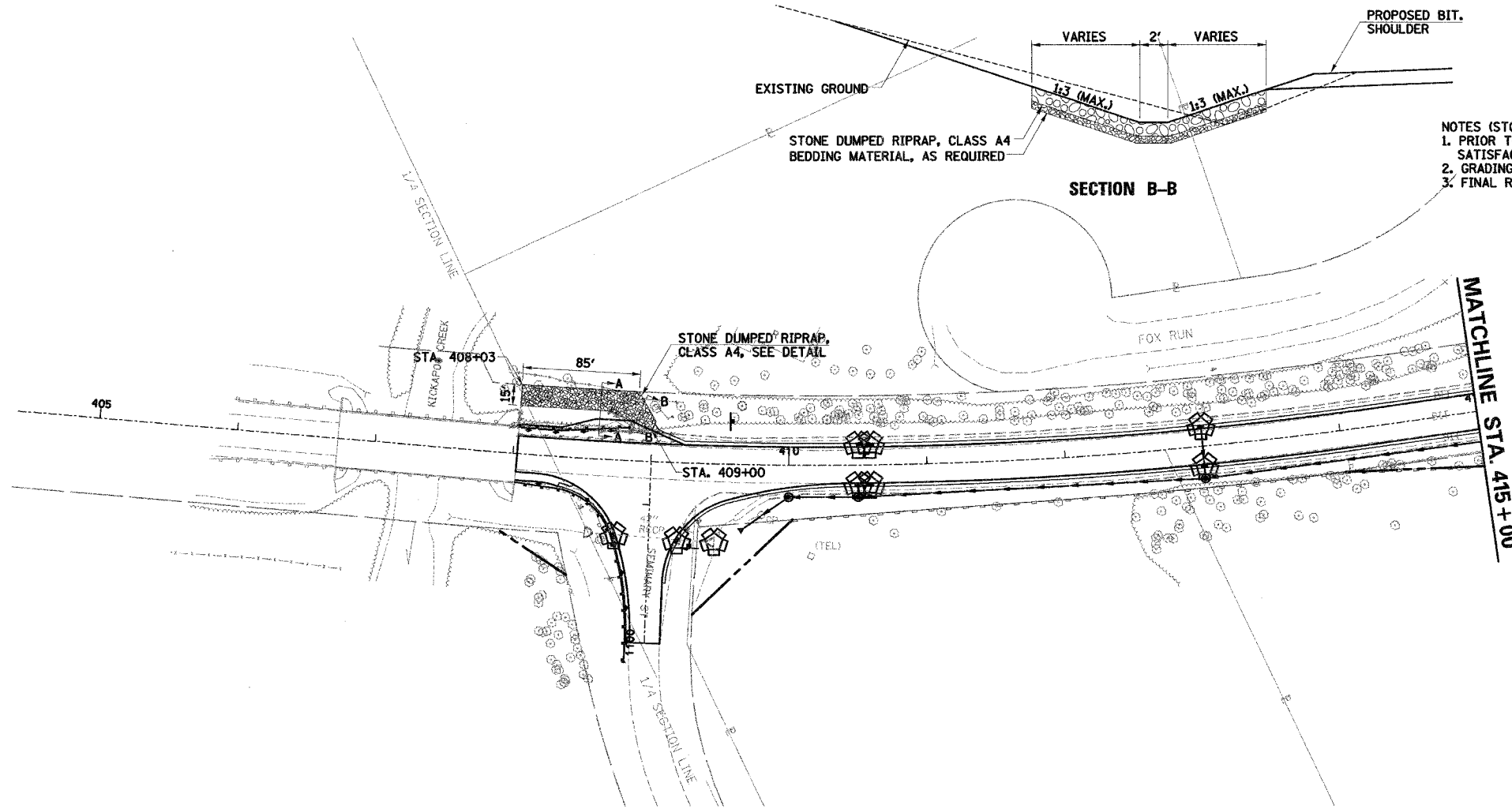

NOTE:
EROSION CONTROL BLANKET SHALL BE INSTALLED AT ALL
END SECTION LOCATIONS (SEE SCHEDULE OF QUANTITIES).

INLET AND PIPE PROTECTION

- 1100+75, 48' RT
- 1100+76, 21' RT
- 1100+77, 26' LT
- 410+50, 15' LT
- 410+50, 15' RT
- 410+59, 15' LT
- 410+59, 15' RT
- 413+00, 15' LT
- 413+00, 15' RT

LEGEND

- PERIMETER EROSION BARRIER
- PROPOSED R.O.W.
- TEMPORARY EASEMENT
- EXISTING R.O.W.

ILLINOIS DEPARTMENT OF TRANSPORTATION
F.A.S. 1517 (U.S. ROUTE 150)
EROSION CONTROL PLAN
STA. 408 + 02.77 TO STA. 415 + 00

SCALE: VERT. _____
HORIZ. _____
DATE _____ DRAWN BY _____
CHECKED BY _____

DATE	BY	PLANNED

DATE	BY	PROFILE

COMPANY NAME: #COMPANY/NAME#
PROJECT CONTACT: #PROJECT_CONTACT#
CLIENT: #CLIENT#
#DATE# #TIME#
#FILE#

F.A.S. RTE.	SECTION	COUNTY	TOTAL SHEETS	SHEET NO.
1517	2)RS-3 (3)RS-4	MCLEAN	223	77
STA.	TO STA.			
FED. ROAD DIST. NO.	ILLINOIS FED. AID PROJECT			

66383

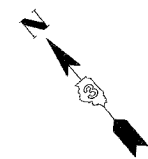
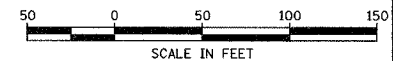

PLAN	BY	DATE
SURVEYED		
NOTE BOOK		
ALIGNED		
CHECKED		
BY		
DATE		

PROFILE	BY	DATE
SURVEYED		
NOTE BOOK		
GRADES CHECKED		
BY		
DATE		

COMPANY NAME: PROJECT CONTACT: PROJECT CONTACTS: CLIENT: AGENT: DATE: SHEET: 66383

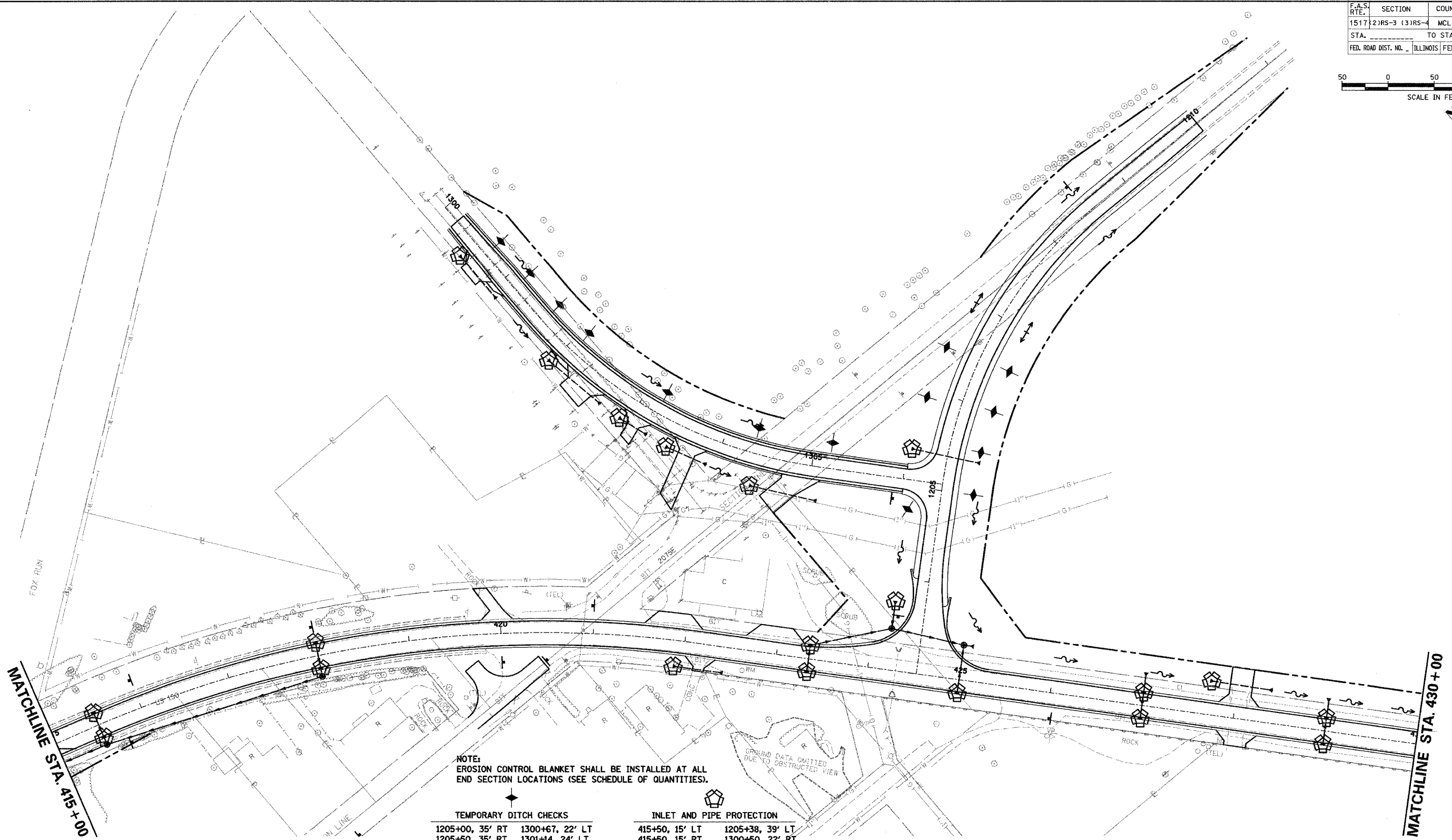

NOTE:
EROSION CONTROL BLANKET SHALL BE INSTALLED AT ALL
END SECTION LOCATIONS (SEE SCHEDULE OF QUANTITIES).

TEMPORARY DITCH CHECKS	
1205+00, 35' RT	1300+67, 22' LT
1205+50, 35' RT	1301+14, 24' LT
1205+92, 38' LT	1301+61, 26' LT
1206+00, 36' RT	1302+08, 27' LT
1206+46, 38' LT	1303+20, 25' LT
1206+50, 35' RT	1304+32, 28' LT
	1305+19, 22' LT
	1306+11, 28' RT

INLET AND PIPE PROTECTION	
415+50, 15' LT	1205+38, 39' LT
415+50, 15' RT	1300+50, 22' RT
418+00, 15' LT	1301+96, 25' RT
418+00, 15' RT	1302+90, 26' RT
421+90, 26' RT	1303+46, 28' RT
423+35, 15.6' LT	1304+40, 35' RT
423+35, 15' RT	
424+20, 75' LT	
425+00, 15' RT	
427+00, 15' LT	
427+00, 15' RT	
427+74, 36' LT	
429+00, 15' LT	
429+00, 15' RT	

LEGEND

	PERIMETER EROSION BARRIER
	PROPOSED R.O.W.
	TEMPORARY EASEMENT
	EXISTING R.O.W.

ILLINOIS DEPARTMENT OF TRANSPORTATION
F.A.S. 1517 (U.S. ROUTE 150)
EROSION CONTROL PLAN
STA. 415+00 TO STA. 430+00

SCALE: VERT. _____
 HORIZ. _____
 DATE _____

DRAWN BY _____
 CHECKED BY _____

F.A.S. RTE.	SECTION	COUNTY	TOTAL SHEETS	SHEET NO.
1517 (2)RS-3 (3)RS-4	MCLEAN	223	78	
STA.	TO STA.			
FED. ROAD DIST. NO.	ILLINOIS FED. AID PROJECT			

66383

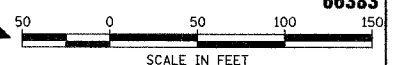

PLAN	NO.	DATE
SURVEYED	BY	DATE
NOTE BOOK	NO.	DATE
ALIGNMENT CHECKED	BY	DATE
CONTOUR CHECKED	BY	DATE
STATIONING CHECKED	BY	DATE

PROFILE	NO.	DATE
SURVEYED	BY	DATE
GRADES CHECKED	BY	DATE
STRUCTURE NOTATIONS CHECKED	BY	DATE

COMPANY NAME: PROJECT NAME:
 PROJECT CONTACT: PROJECT CONTACT #:
 CLIENT: CLIENT #:
 DATE: DATE #:
 SHEET: SHEET #:

MATCHLINE STA. 430+00

MATCHLINE STA. 445+00

MATCHLINE STA. 445+00

MATCHLINE STA. 460+00

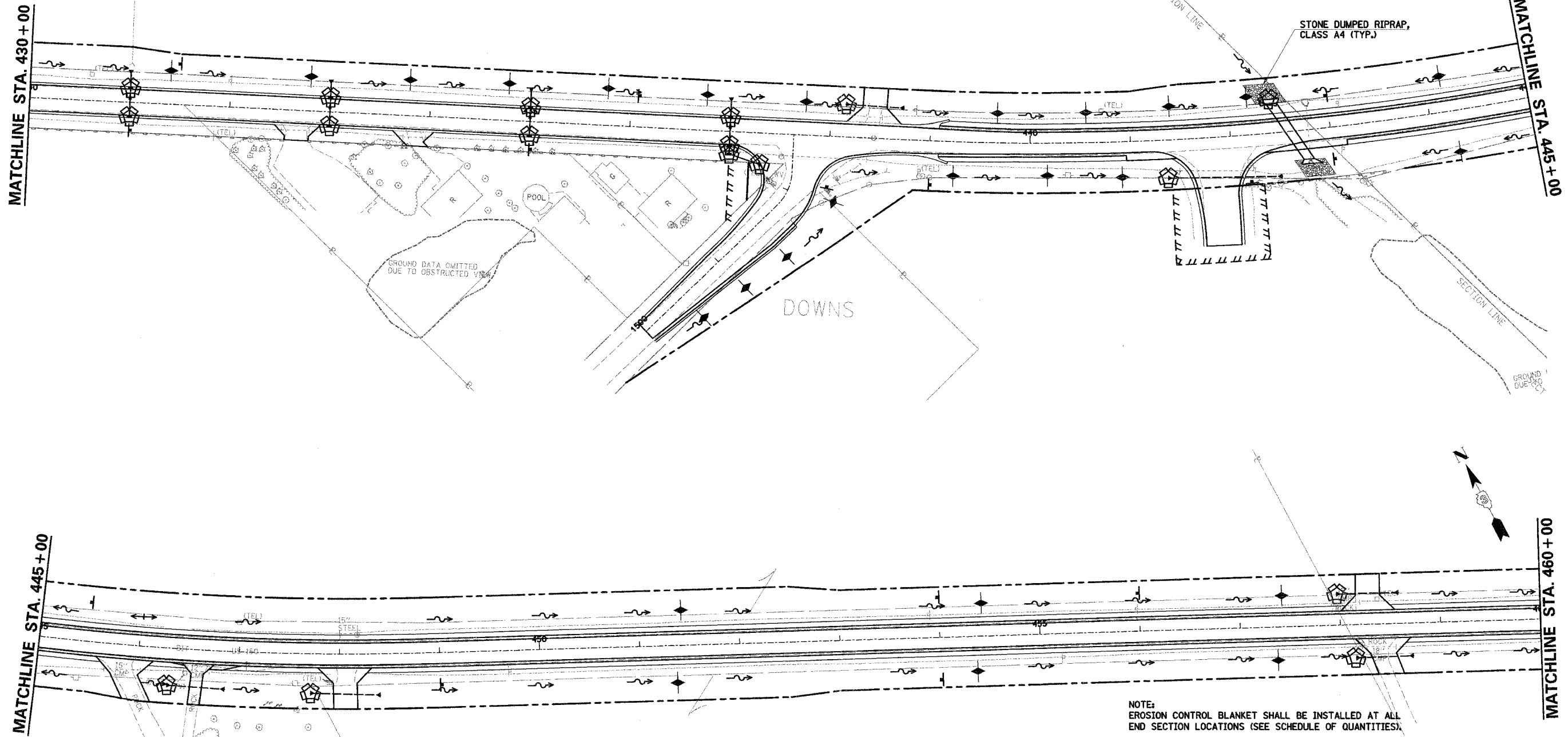

NOTE:
 EROSION CONTROL BLANKET SHALL BE INSTALLED AT ALL
 END SECTION LOCATIONS (SEE SCHEDULE OF QUANTITIES).

LEGEND

-----	PERIMETER EROSION BARRIER
-----	PROPOSED R.O.W.
	TEMPORARY EASEMENT
-----	EXISTING R.O.W.

TEMPORARY DITCH CHECKS

431+40, 33' LT	439+24, 34' RT
432+80, 34' LT	439+67, 30' LT
433+79, 36' LT	440+17, 33' RT
434+78, 37' LT	440+56, 30' LT
435+77, 37' LT	440+91, 35' RT
436+76, 36' LT	441+40, 34' LT
437+75, 33' LT	442+20, 38' LT

TEMPORARY DITCH CHECKS

444+15, 36' LT	457+42, 31' LT
444+25, 41' RT	1500+51, 30' RT
451+37, 37' RT	1501+02, 37' RT
451+42, 35' LT	1501+53, 44' RT
454+37, 35' RT	1502+04, 47' RT
454+42, 33' LT	
457+37, 33' RT	

INLET AND PIPE PROTECTION

431+00, 15' LT	437+31.88, 31.1' RT
431+00, 15' RT	438+15, 32' LT
433+00, 15' LT	441+36, 38' RT
433+00, 15' RT	442+40, 34' LT
435+00, 15' LT	446+30, 37' RT
435+00, 15' RT	447+71, 40' RT
437+00, 15' LT	457+97, 31' LT
437+00, 15' RT	458+15, 33' RT
437+00, 22.5' RT	

ILLINOIS DEPARTMENT OF TRANSPORTATION
 F.A.S. 1517 (U.S. ROUTE 150)
EROSION CONTROL PLAN
 STA. 430+00 TO STA. 460+00

SCALE: VERT. _____
 HORIZ. _____
 DATE _____

DRAWN BY _____
 CHECKED BY _____

F.A.S. RTE.	SECTION	COUNTY	TOTAL SHEETS	SHEET NO.
1517 (2)RS-3 (3)RS-4		MCLEAN	223	79
STA.	TO STA.			
FED. ROAD DIST. NO.	ILLINOIS FED. AID PROJECT			

66383

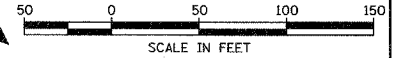

PLAN	SURVEYED	DATE
NOTE BOOK	ALIGNMENT CHECKED	
NO.	PT. OF MAP CHECKED	
	DATE FILE NAME	

PROFILE	SURVEYED	DATE
NOTE BOOK	GRADES CHECKED	
NO.	STATIONING NOTATIONS CHKD	

COMPANY NAME: #COMPANY NAME#
 PROJECT CONTACT: #PROJECT CONTACT#
 CLIENT: #CLIENT#
 DATES: #DATES#
 SHEETS: #SHEETS#

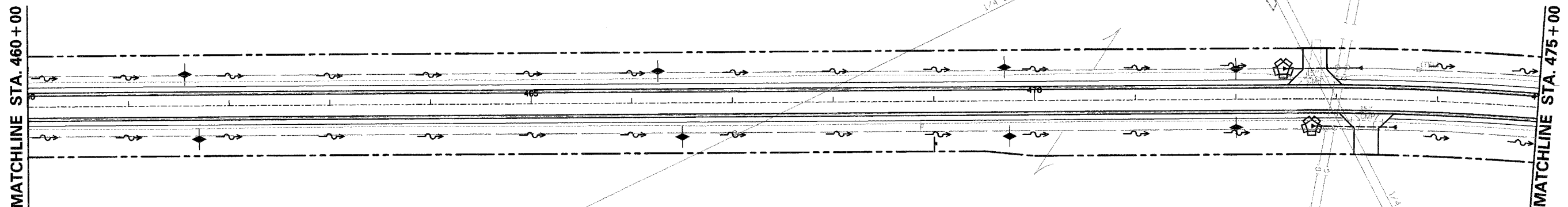

NOTE:
 EROSION CONTROL BLANKET SHALL BE INSTALLED AT ALL
 END SECTION LOCATIONS (SEE SCHEDULE OF QUANTITIES).

TEMPORARY DITCH CHECKS	
461+56, 31' LT	472+00, 28' RT
461+70, 33' RT	475+64, 38' LT
466+26, 32' LT	475+77, 39' RT
466+50, 34' RT	480+64, 30' LT
469+70, 33' LT	480+77, 32' RT
469+75, 35' RT	488+90, 48' LT
472+00, 30' LT	488+90, 50' RT

INLET AND PIPE PROTECTION
472+47, 30' LT
472+75, 27' RT
476+00, 33' LT

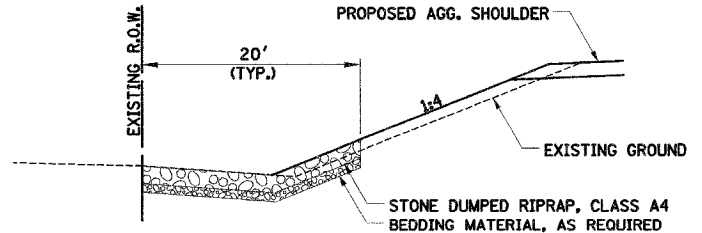
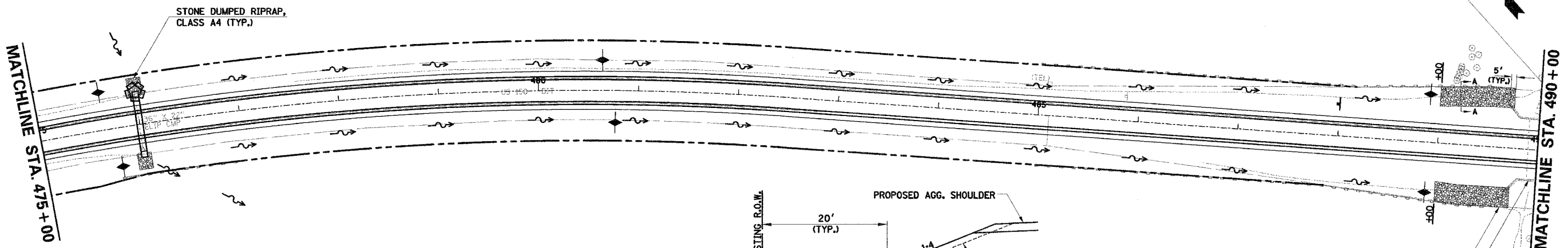

SECTION A-A
 (DETAIL APPLIES TO BOTH LEFT AND RIGHT SIDES OF U.S. ROUTE 150)

NOTES (STONE DUMPED RIPRAP):
 1. ERODED CHANNEL BANKS ADJACENT TO THE STRUCTURE WINGWALLS SHALL BE GRADED TO THE SATISFACTION OF THE ENGINEER.
 2. FINAL RIPRAP PLACEMENT IS SUBJECT TO THE APPROVAL OF THE ENGINEER.

LEGEND

	PERIMETER EROSION BARRIER
	PROPOSED R.O.W.
	TEMPORARY EASEMENT
	EXISTING R.O.W.

STONE DUMPED RIPRAP,
 CLASS A4 (TYP.) - SEE DETAIL
 SN 057-2034
 EX. DOUBLE 12' X 10' RCBC

ILLINOIS DEPARTMENT OF TRANSPORTATION
 F.A.S. 1517 (U.S. ROUTE 150)
 EROSION CONTROL PLAN
 STA. 460+00 TO STA. 490+00
 SCALE: VERT. _____
 DATE _____ HORIZ. _____
 DRAWN BY _____
 CHECKED BY _____

F.A.S. RTE.	SECTION	COUNTY	TOTAL SHEETS	SHEET NO.
1517 (2)RS-3 (3)RS-4		MCLEAN	223	80
STA.	TO STA.			
FED. ROAD DIST. NO.	ILLINOIS FED. AID PROJECT			

66383

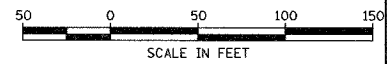

PLAN	SURVEYED	DATE
NOTE BOOK	ALIGNED	
NO.	CHECKED	
	BY	
	DATE	

PROFILE	SURVEYED	DATE
NOTE BOOK	GRADES	
NO.	CHECKED	
	BY	
	DATE	

COMPANY NAME: #COMPANY/NAME#
 PROJECT CONTACT: #PROJECT/CONTACT#
 CLIENT: #CLIENT/F#
 ROUTE: #ROUTE#
 SHEET: #SHEET#

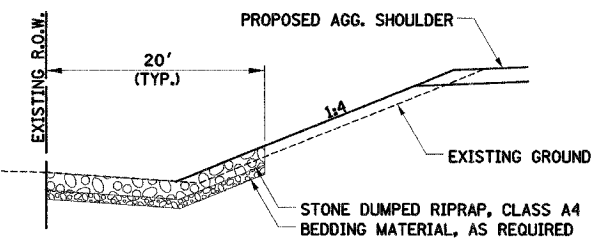
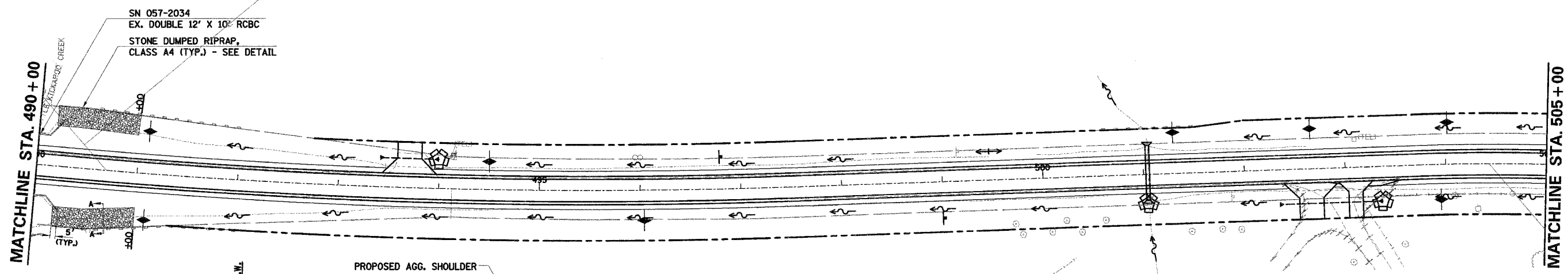

SECTION A-A
 (DETAIL APPLIES TO BOTH LEFT AND RIGHT SIDES OF U.S. ROUTE 150)

- NOTES (STONE DUMPED RIPRAP):
1. ERODED CHANNEL BANKS ADJACENT TO THE STRUCTURE WINGWALLS SHALL BE GRADED TO THE SATISFACTION OF THE ENGINEER.
 2. FINAL RIPRAP PLACEMENT IS SUBJECT TO THE APPROVAL OF THE ENGINEER.

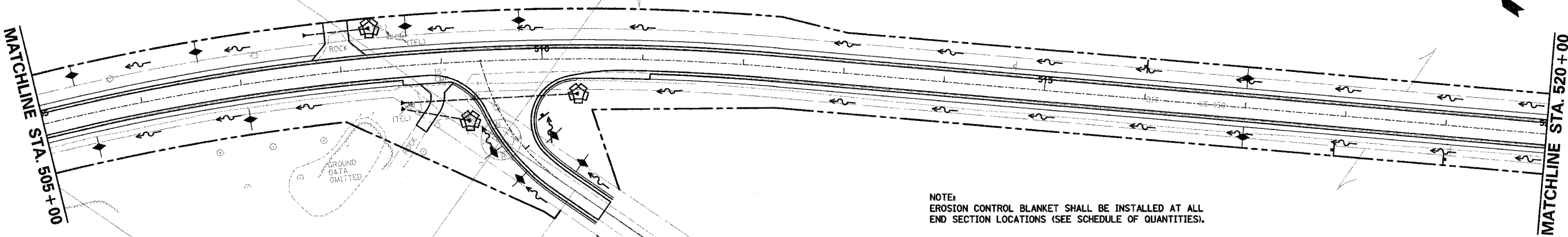

LEGEND

	PERIMETER EROSION BARRIER
	PROPOSED R.O.W.
	TEMPORARY EASEMENT
	EXISTING R.O.W.

TEMPORARY DITCH CHECKS

491+10, 42' LT	506+61, 39' LT
491+10, 46' LT	507+04, 35' RT
494+50, 28' LT	508+67, 39' LT
496+04, 30' RT	509+78, 39' LT
501+30, 41' LT	517+00, 29' LT
502+66, 40' LT	517+00, 29' RT
503+95, 35' RT	1601+45, 27' RT
504+02, 42' LT	1601+83, 24' LT
505+38, 41' LT	1601+90, 30' RT
505+49, 34' RT	1602+16, 26' LT

INLET AND PIPE PROTECTION

494+00, 29' LT
501+04, 29' RT
503+37, 34' RT
508+32, 40' LT
509+25, 58' RT
510+36, 34' RT

ILLINOIS DEPARTMENT OF TRANSPORTATION
F.A.S. 1517 (U.S. ROUTE 150)
EROSION CONTROL PLAN
STA. 490+00 TO STA. 520+00

SCALE: VERT. _____
 HORIZ. _____
 DATE _____

DRAWN BY _____
 CHECKED BY _____

F.A.S. RTE.	SECTION	COUNTY	TOTAL SHEETS	SHEET NO.
1517 (2)RS-3 (3)RS-4		MCLEAN	223	81
STA.	TO STA.			
FED. ROAD DIST. NO.	ILLINOIS FED. AID PROJECT			

66383

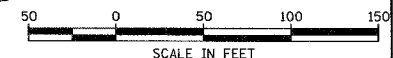

DATE	BY	SURVEYED	ALIGNED	CHECKED
PLAN	NOTE BOOK NO.	FILE NAME		

DATE	BY	SURVEYED	GRADES CHECKED	NOTES CHECKED
PROFILE	NOTE BOOK NO.	FILE NAME		

COMPANY NAME: #COMPANY/NAME#
 PROJECT CONTACT: #PROJECT_CONTACT#
 CLIENT: #CLIENT#
 DATED: #DATE#
 BY: #BY#

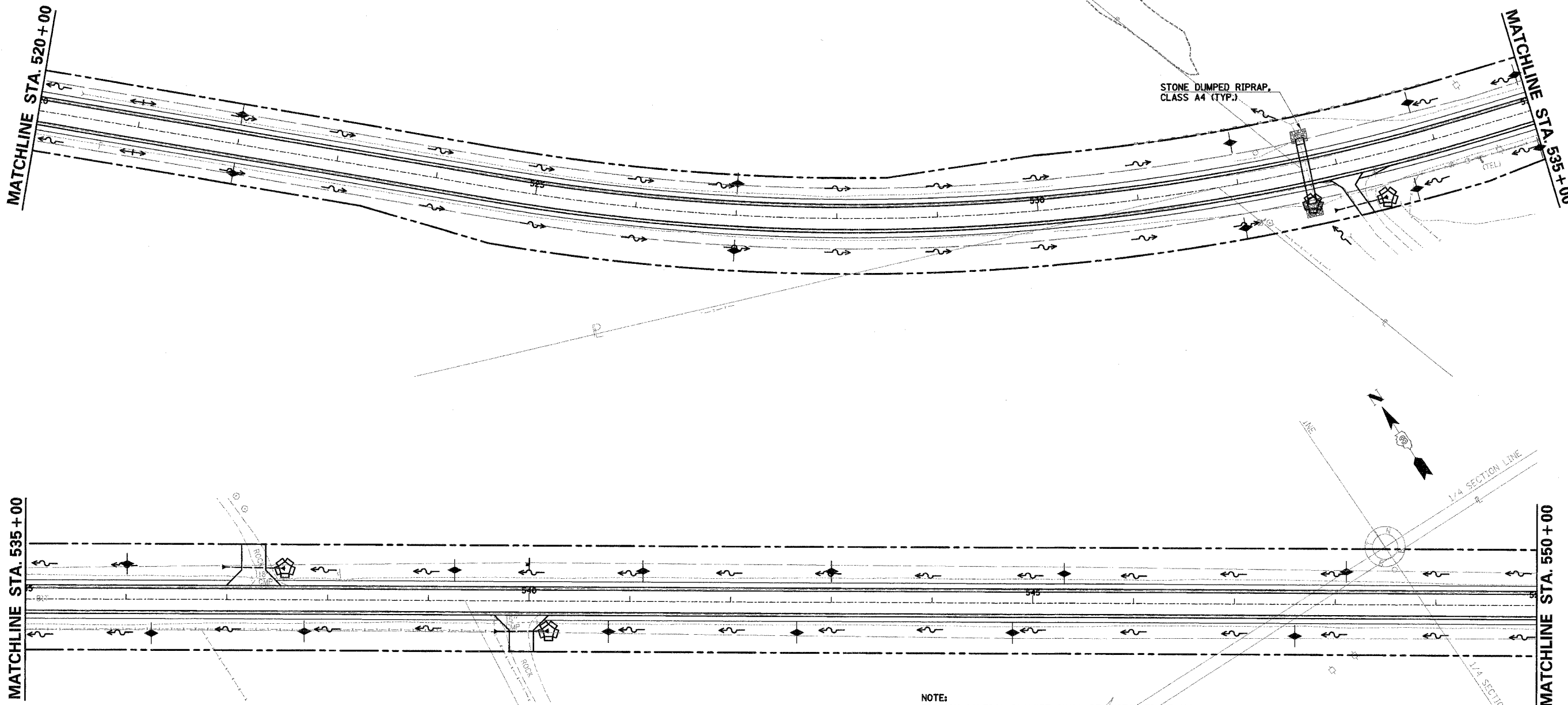

NOTE:
 EROSION CONTROL BLANKET SHALL BE INSTALLED AT ALL
 END SECTION LOCATIONS (SEE SCHEDULE OF QUANTITIES).

LEGEND

	PERIMETER EROSION BARRIER
	PROPOSED R.O.W.
	TEMPORARY EASEMENT
	EXISTING R.O.W.

TEMPORARY DITCH CHECKS		INLET AND PIPE PROTECTION	
522+00, 30' LT	536+25, 34' RT	532+69, 33' RT	
522+00, 30' RT	537+77, 31' RT	533+42, 45' RT	
527+00, 32' LT	539+26, 30' LT	537+58, 32' LT	
527+00, 35' RT	540+79, 30' RT	540+20, 31' RT	
532+00, 42' LT	541+13, 30' LT		
532+00, 44' RT	542+66, 30' RT		
533+71, 43' RT	543+00, 31' LT		
533+84, 42' LT	544+80, 29' RT		
534+95, 39' LT	545+31, 29' LT		
534+98, 38' RT	547+60, 32' RT		
536+01, 35' LT	548+11, 32' LT		

ILLINOIS DEPARTMENT OF TRANSPORTATION
 F.A.S. 1517 (U.S. ROUTE 150)
EROSION CONTROL PLAN
 STA. 520+00 TO STA. 550+00

SCALE: VERT. _____
 HORIZ. _____
 DATE _____

DRAWN BY _____
 CHECKED BY _____

F.A.S. RTE.	SECTION	COUNTY	TOTAL SHEETS	SHEET NO.
1517 (2)RS-3 (3)RS-4		MCLEAN	223	82
STA. _____ TO STA. _____		FED. ROAD DIST. NO. _____ ILLINOIS FED. AID PROJECT		

66383

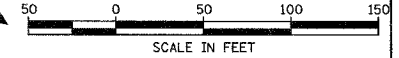

PLAN	SURVEYED	BY	DATE
	NOTE BOOK		
	ALIGNMENT CHECKED		
	AS SHOWN		
	DATE		

PROFILE	SURVEYED	BY	DATE
	GRADES CHECKED		
	AS SHOWN		
	DATE		

COMPANY NAME: #COMPANY/NAME#
 PROJECT CONTACT: #PROJECT_CONTACT#
 CLIENT: #CLIENT/FF#
 #DATES# #TIMES#
 #FILES#

MATCHLINE STA. 550+00

MATCHLINE STA. 565+00

MATCHLINE STA. 565+00

MATCHLINE STA. 580+00

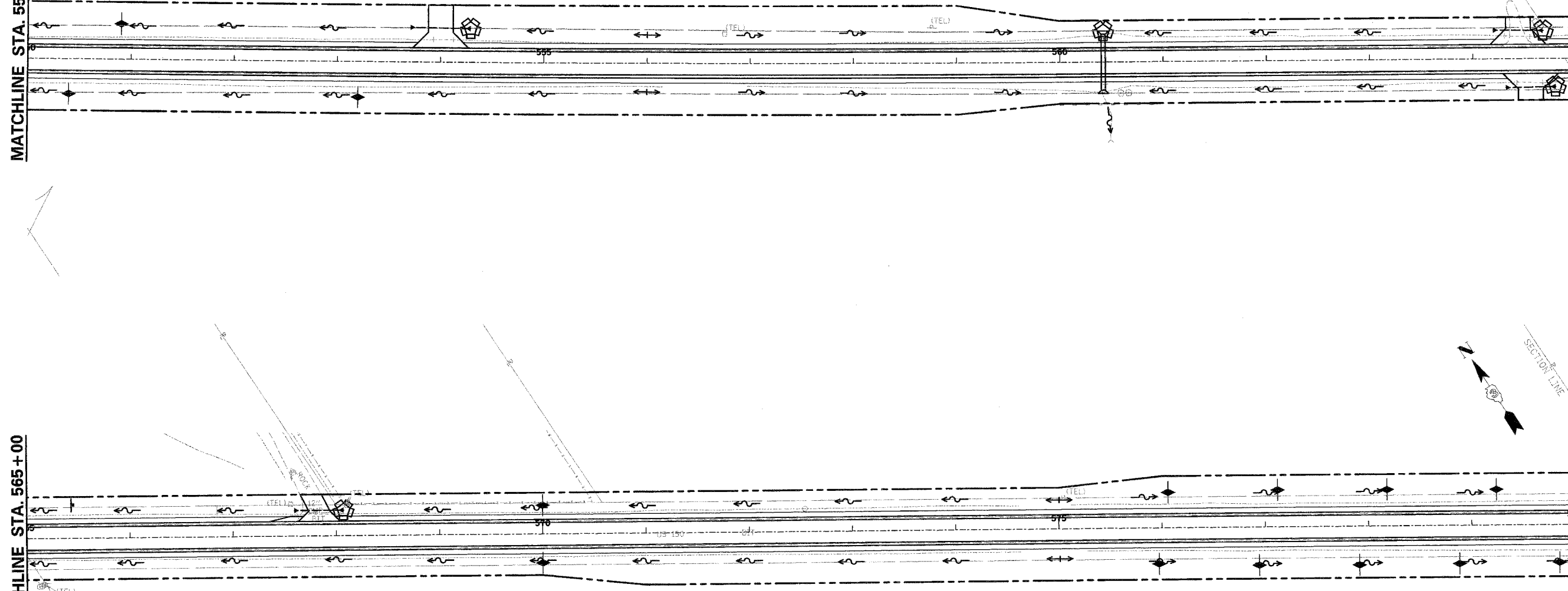

NOTE:
 EROSION CONTROL BLANKET SHALL BE INSTALLED AT ALL
 END SECTION LOCATIONS (SEE SCHEDULE OF QUANTITIES).

LEGEND

- PERIMETER EROSION BARRIER
- PROPOSED R.O.W.
- ||||| TEMPORARY EASEMENT
- EXISTING R.O.W.

TEMPORARY DITCH CHECKS

550+40, 34' RT	576+94, 37' RT
550+91, 34' LT	577+12, 36' LT
553+20, 34' RT	577+91, 37' RT
570+00, 28' LT	578+18, 35' LT
570+00, 28' RT	578+88, 37' RT
575+97, 35' RT	579+24, 35' LT
576+06, 34' LT	579+85, 36' RT

INLET AND PIPE PROTECTION

554+29, 35' LT
560+42, 30' LT
564+68, 27' LT
564+80, 28' RT
568+07, 26' LT

ILLINOIS DEPARTMENT OF TRANSPORTATION
 F.A.S. 1517 (U.S. ROUTE 150)
 EROSION CONTROL PLAN
 STA. 550+00 TO STA. 580+00

SCALE: VERT. _____
 HORIZ. _____
 DATE _____ DRAWN BY _____
 CHECKED BY _____

F.A.S. RTE.	SECTION	COUNTY	TOTAL SHEETS	SHEET NO.
1517 (2)RS-3 (3)RS-4		MCLEAN	223	83
STA.	TO STA.			
FED. ROAD DIST. NO.	ILLINOIS FED. AID PROJECT			

66383

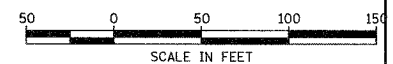

PLAN	SURVEYED	BY	DATE
	NOTE BOOK		
	ALIGNMENT CHECKED		
	OF FILE NAME		
	NO.		

PROFILE	SURVEYED	BY	DATE
	GRADES CHECKED		
	BY		
	NO.		

COMPANY NAME: #COMPANY/NAME#
 PROJECT CONTACT: #PROJECT/CONTACT#
 CLIENT: #CLIENT/#
 #DATE# #TIME#
 #FILES

MATCHLINE STA. 580+00

MATCHLINE STA. 595+00

MATCHLINE STA. 595+00

MATCHLINE STA. 610+00

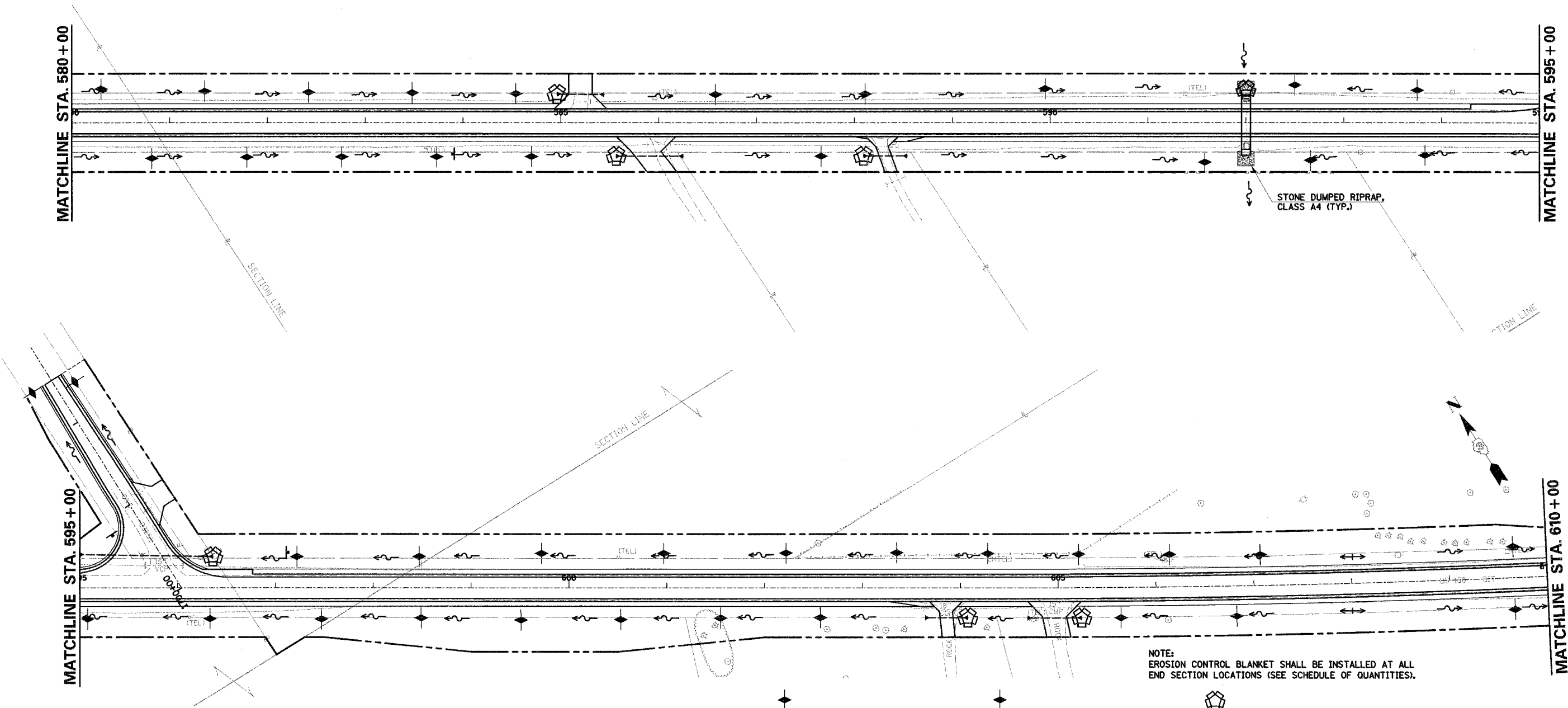

NOTE:
 EROSION CONTROL BLANKET SHALL BE INSTALLED AT ALL
 END SECTION LOCATIONS (SEE SCHEDULE OF QUANTITIES).

LEGEND

- PERIMETER EROSION BARRIER
- PROPOSED R.O.W.
- ||||| TEMPORARY EASEMENT
- EXISTING R.O.W.

TEMPORARY DITCH CHECKS

580+30, 34' LT	586+58, 29' LT
580+82, 36' RT	587+66, 34' RT
581+36, 32' LT	588+11, 29' LT
581+79, 35' RT	589+95, 35' LT
582+42, 31' LT	591+58, 40' RT
582+76, 35' RT	592+50, 38' LT
583+48, 30' LT	592+66, 38' RT
583+73, 35' RT	593+75, 33' LT
584+54, 30' LT	593+83, 33' RT
584+70, 34' RT	595+08, 31' RT

TEMPORARY DITCH CHECKS

596+33, 31' RT	602+57, 30' RT
597+22, 32' LT	603+35, 36' LT
597+47, 31' RT	604+28, 35' LT
598+47, 32' LT	605+21, 34' LT
598+49, 30' RT	605+64, 31' RT
599+51, 32' RT	606+14, 33' LT
599+72, 35' LT	606+82, 30' RT
600+53, 32' RT	607+07, 32' LT
600+97, 35' LT	609+66, 32' LT
601+55, 30' RT	609+66, 32' RT
602+22, 36' LT	1702+36, 20' RT
	1702+50, 23' LT

INLET AND PIPE PROTECTION

584+96, 30' LT
585+57, 36' RT
588+09, 35' RT
592+00, 33' LT
596+36, 32' LT
604+08, 30' RT
605+24, 31' RT

ILLINOIS DEPARTMENT OF TRANSPORTATION
 F.A.S. 1517 (U.S. ROUTE 150)
 EROSION CONTROL PLAN
 STA. 580+00 TO STA. 610+00

SCALE: VERT. _____
 HORIZ. _____
 DATE _____

DRAWN BY _____
 CHECKED BY _____

F.A.S. RTE.	SECTION	COUNTY	TOTAL SHEETS	SHEET NO.
1517 (2)RS-3 (3)RS-4		MCLEAN	223	84
STA. _____		TO STA. _____		
FED. ROAD DIST. NO. _____ ILLINOIS FED. AID PROJECT				

66383

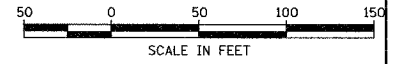

PLAN	SURVEYED	BY	DATE
	NOTE BOOK		
	ALIGNED		
	CHECKED		
	BY M.A. GIBSON		
	PAID FILE NAME		

PROFILE	SURVEYED	BY	DATE
	NOTE BOOK		
	ALIGNED		
	CHECKED		
	BY M.A. GIBSON		
	PAID FILE NAME		

COMPANY NAME: #COMPANY.WME#
 PROJECT CONTACT: #PROJECT.CONTACT#
 CLIENT: #CLIENT#
 #DATE#
 #FILES#

MATCHLINE STA. 610 + 00

MATCHLINE STA. 625 + 00

MATCHLINE STA. 625 + 00

MATCHLINE STA. 640 + 00

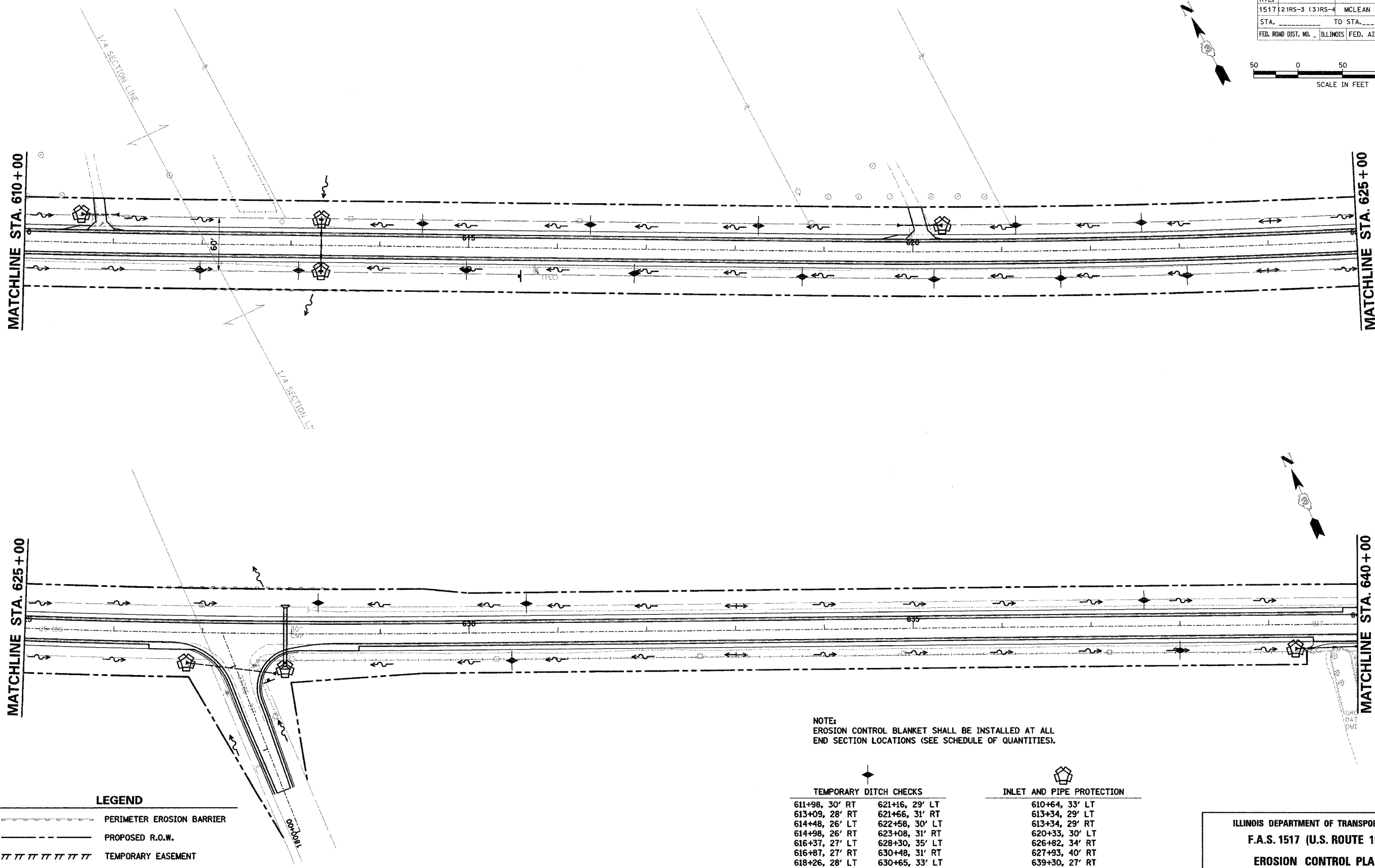

NOTE:
 EROSION CONTROL BLANKET SHALL BE INSTALLED AT ALL
 END SECTION LOCATIONS (SEE SCHEDULE OF QUANTITIES).

LEGEND

- PERIMETER EROSION BARRIER
- PROPOSED R.O.W.
- ||||| TEMPORARY EASEMENT
- EXISTING R.O.W.

TEMPORARY DITCH CHECKS

611+98, 30' RT	621+16, 29' LT
613+09, 28' RT	621+66, 31' RT
614+48, 26' LT	622+58, 30' LT
614+98, 26' RT	623+08, 31' RT
616+37, 27' LT	628+30, 35' LT
616+87, 27' RT	630+48, 31' RT
618+26, 28' LT	630+65, 33' LT
618+76, 29' RT	637+60, 29' LT
620+24, 31' RT	638+00, 28' RT

INLET AND PIPE PROTECTION

610+64, 33' LT
613+34, 29' LT
613+34, 29' RT
620+33, 30' LT
626+82, 34' RT
627+93, 40' RT
639+30, 27' RT

ILLINOIS DEPARTMENT OF TRANSPORTATION
 F.A.S. 1517 (U.S. ROUTE 150)
 EROSION CONTROL PLAN
 STA. 610 + 00 TO STA. 640 + 00

SCALE: VERT. _____
 HORIZ. _____
 DATE _____

DRAWN BY _____
 CHECKED BY _____

F.A.S. RTE.	SECTION	COUNTY	TOTAL SHEETS	SHEET NO.
1517 (2)RS-3 (3)RS-4		MCLEAN	223	85
STA.	TO STA.			
FED. ROAD DIST. NO.	ILLINOIS FED. AID PROJECT			

66383

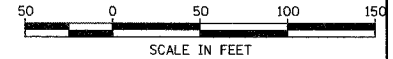

PLAN	SURVEYED	BY	DATE
	NOTE BOOK		
	ALIGNED		
	CHECKED		
	BY		
	NO.		

PROFILE	SURVEYED	BY	DATE
	GRADES CHECKED		
	REL. NOTED		
	STRUCTURE NOTATIONS CHECKED		
	NO.		

COMPANY NAME: #COMPANY NAME#
 PROJECT CONTACT: #PROJECT CONTACT#
 CLIENT: #CLIENT#
 #DATE#
 #FILE#

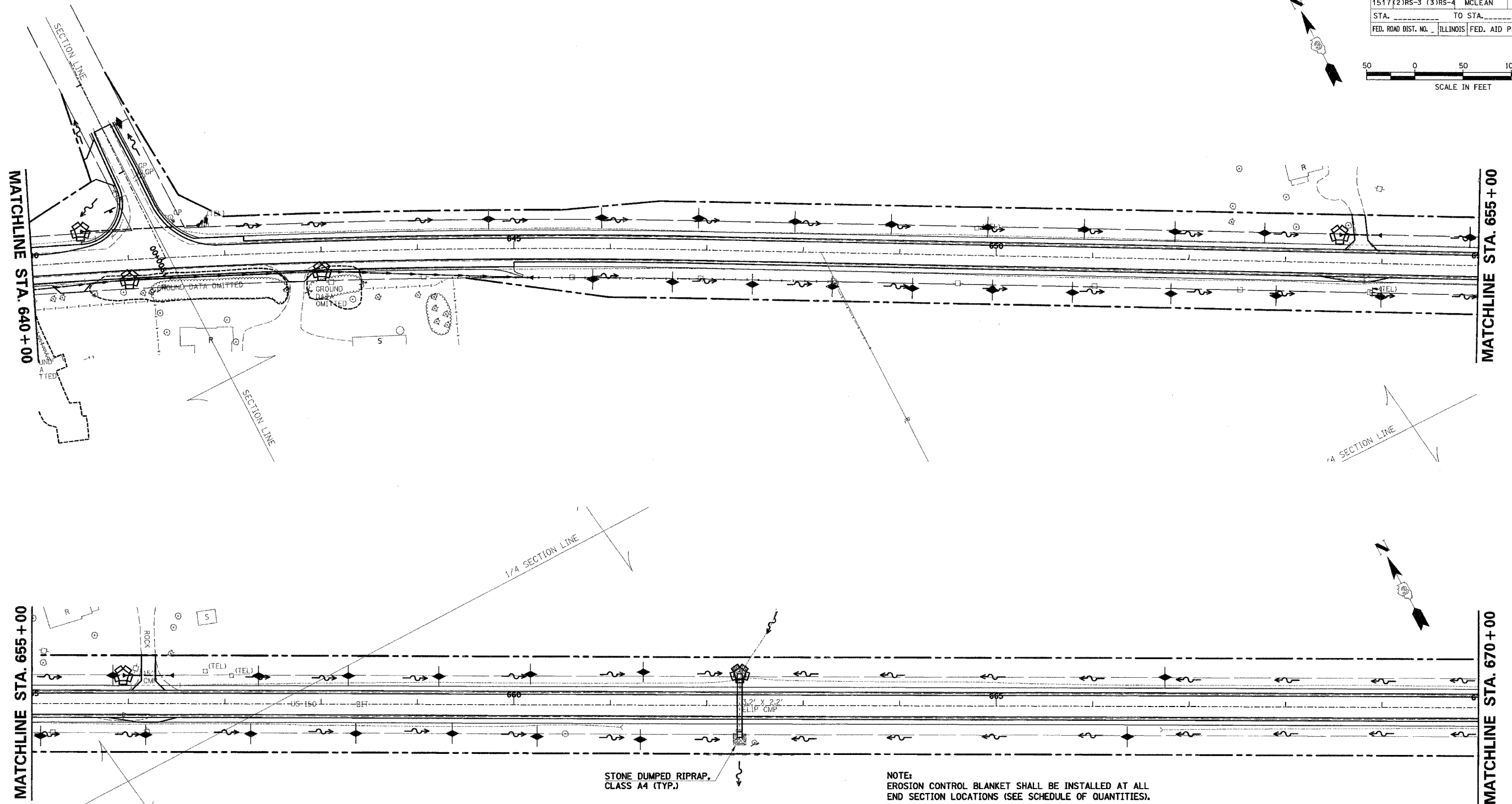

LEGEND

	PERIMETER EROSION BARRIER
	PROPOSED R.O.W.
	TEMPORARY EASEMENT
	EXISTING R.O.W.

STONE DUMPED RIPRAP,
CLASS A4 (TYP.)

NOTE:
EROSION CONTROL BLANKET SHALL BE INSTALLED AT ALL
END SECTION LOCATIONS (SEE SCHEDULE OF QUANTITIES).

TEMPORARY DITCH CHECKS

644+74, 31' LT	648+91, 30' LT
645+82, 32' RT	649+14, 35' RT
645+91, 32' LT	649+91, 29' LT
646+65, 33' RT	649+97, 35' RT
646+91, 33' LT	650+80, 36' RT
647+48, 34' RT	650+91, 29' LT
647+91, 31' LT	651+82, 35' RT
648+31, 35' RT	651+85, 29' LT
	652+78, 29' LT

TEMPORARY DITCH CHECKS

652+91, 35' RT	659+22, 29' LT
654+00, 34' RT	659+36, 30' RT
654+91, 30' LT	660+17, 32' LT
655+09, 33' RT	660+24, 33' RT
655+84, 29' LT	661+31, 35' RT
656+18, 32' RT	661+34, 34' LT
657+27, 31' RT	666+36, 31' RT
657+35, 29' LT	666+75, 30' LT
658+28, 30' LT	1901+47, 18' RT
658+36, 30' RT	

INLET AND PIPE PROTECTION

640+52, 32' LT
641+00, 13' RT
643+00, 13' RT
653+55, 30' LT
655+94, 30' LT
662+34, 33' LT

ILLINOIS DEPARTMENT OF TRANSPORTATION
F.A.S. 1517 (U.S. ROUTE 150)
EROSION CONTROL PLAN
STA. 640+00 TO STA. 670+00

SCALE: VERT. _____
 HORIZ. _____
 DATE _____

DRAWN BY _____
 CHECKED BY _____

F.A.S. RTE.	SECTION	COUNTY	TOTAL SHEETS	SHEET NO.
1517 (2)RS-3 (3)RS-4	MCLEAN	223	86	
STA. _____ TO STA. _____		ILLINOIS FED. AID PROJECT		

66383

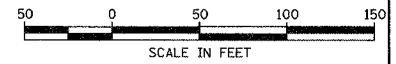

PLAN	NO.	DATE
SURVEYED	BY	
ALIGNED	BY	
CHECKED	BY	
FIELD FILE NAME		

PROFILE	NO.	DATE
SURVEYED	BY	
GRADES CHECKED	BY	
BLK. NOTED	BY	
STRUCTURE NOTATIONS CHECKED	BY	

COMPANY NAME: #COMPANY/NAME#
 PROJECT CONTACT: #PROJECT_CONTACT#
 CLIENT: #CLIENT#
 DATE: #DATE#
 TIME: #TIME#
 FILES:

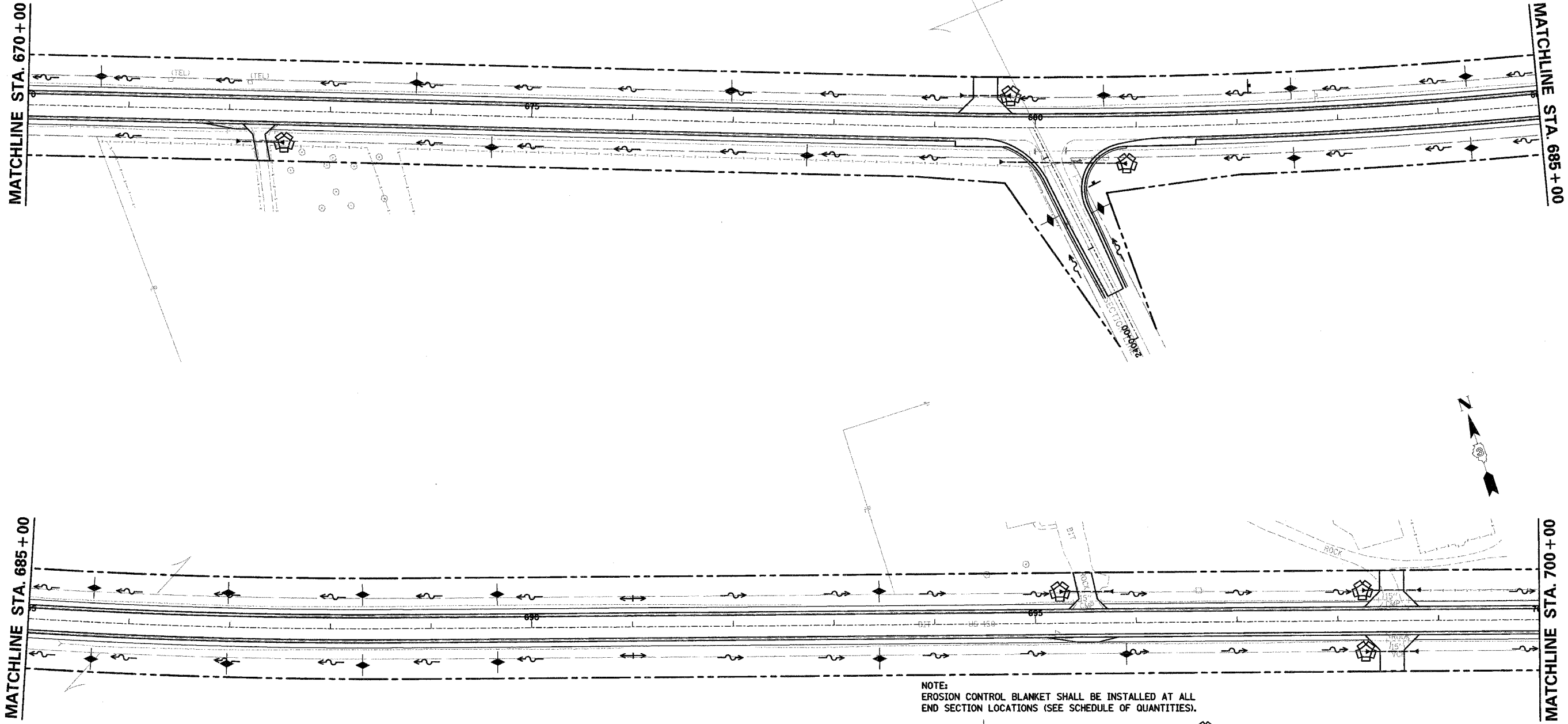

NOTE:
 EROSION CONTROL BLANKET SHALL BE INSTALLED AT ALL
 END SECTION LOCATIONS (SEE SCHEDULE OF QUANTITIES).

LEGEND

-----	PERIMETER EROSION BARRIER
-----	PROPOSED R.O.W.
	TEMPORARY EASEMENT
-----	EXISTING R.O.W.

TEMPORARY DITCH CHECKS

670+72, 30' LT	685+64, 36' RT
673+85, 31' LT	686+98, 34' LT
674+61, 31' RT	686+98, 36' RT
676+98, 31' LT	688+32, 34' LT
677+74, 31' RT	688+32, 36' RT
680+68, 32' LT	689+66, 33' LT
682+55, 33' LT	689+66, 34' RT
682+55, 36' RT	693+45, 33' LT
684+30, 35' LT	693+45, 33' RT
684+30, 37' RT	695+90, 31' RT
685+64, 34' LT	2401+31, 24' RT
	2401+43, 26' LT

INLET AND PIPE PROTECTION

672+55, 32' RT
679+75, 32' LT
680+90, 36' RT
695+24, 32' LT
698+24, 31' LT
698+24, 31' RT

ILLINOIS DEPARTMENT OF TRANSPORTATION
 F.A.S. 1517 (U.S. ROUTE 150)
EROSION CONTROL PLAN
 STA. 670+00 TO STA. 700+00

SCALE: VERT. _____
 HORIZ. _____
 DATE _____

DRAWN BY _____
 CHECKED BY _____

F.A.S. RTE.	SECTION	COUNTY	TOTAL SHEETS	SHEET NO.
1517 (2)RS-3 (3)RS-4		MCLEAN	223	87
STA.	TO STA.			
FED. ROAD DIST. NO.	ILLINOIS FED. AID PROJECT			

66383

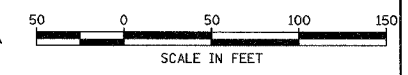

DATE	BY	BY
DATE	BY	BY

DATE	BY	BY
DATE	BY	BY

COMPANY NAME: #COMPANY NAME#
 PROJECT CONTACT: #PROJECT CONTACT#
 CLIENT: #CLIENT#
 DATE: #DATE#
 PRINTER:

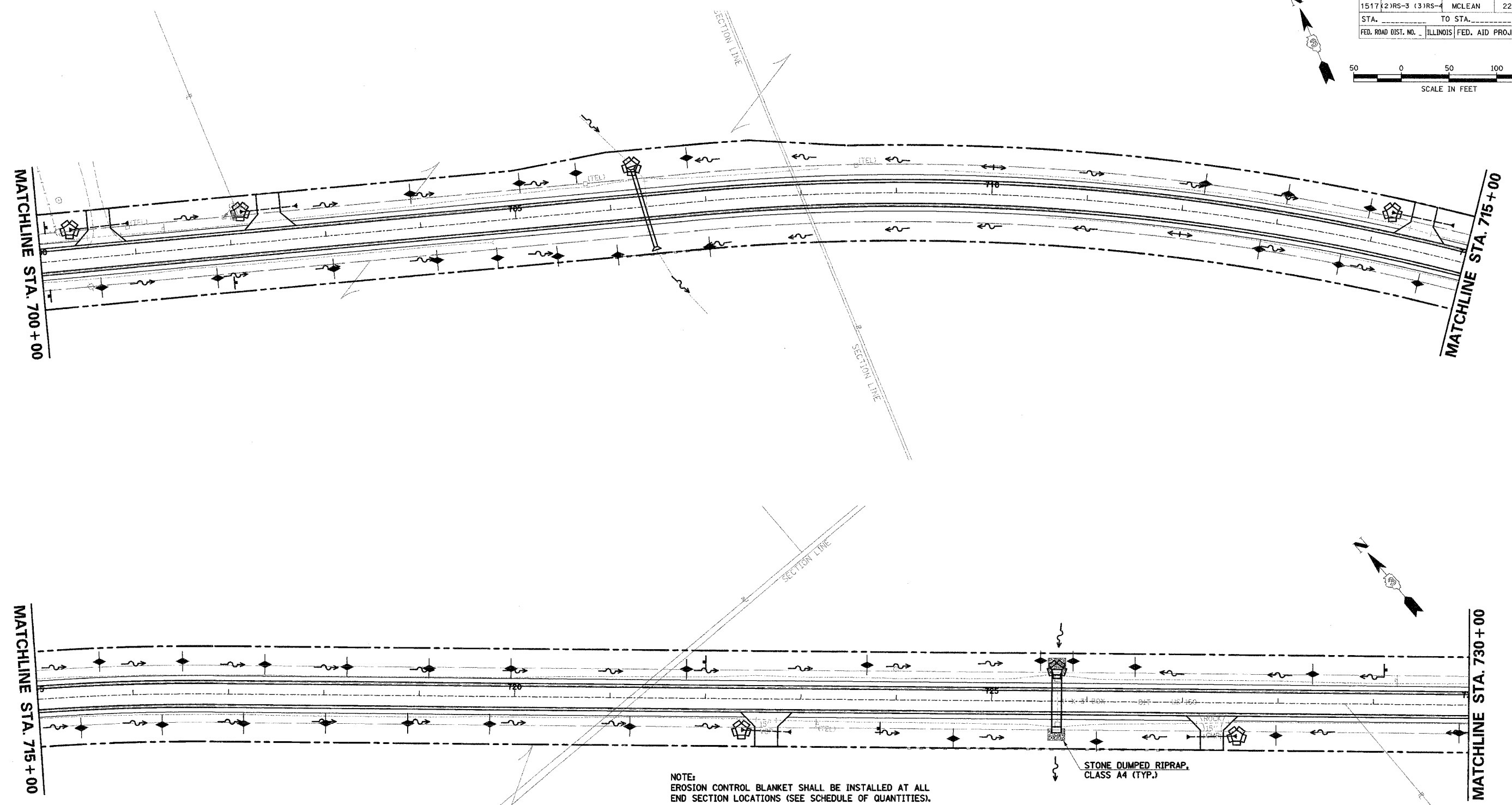

NOTE:
 EROSION CONTROL BLANKET SHALL BE INSTALLED AT ALL
 END SECTION LOCATIONS (SEE SCHEDULE OF QUANTITIES).

STONE DUMPED RIPRAP,
 CLASS A4 (TYP.)

LEGEND	
	PERIMETER EROSION BARRIER
	PROPOSED R.O.W.
	TEMPORARY EASEMENT
	EXISTING R.O.W.

TEMPORARY DITCH CHECKS	
700+61, 32' RT	706+84, 47' LT
701+83, 33' RT	707+00, 48' RT
703+05, 35' RT	712+21, 31' LT
703+92, 36' LT	712+86, 29' RT
704+14, 36' RT	713+07, 33' LT
704+77, 39' RT	713+72, 30' RT
705+07, 37' LT	713+93, 34' LT
705+40, 43' RT	714+58, 32' RT
705+67, 42' LT	715+44, 33' RT
706+03, 48' RT	

TEMPORARY DITCH CHECKS	
715+66, 36' LT	721+21, 30' RT
716+30, 32' RT	721+80, 30' LT
716+52, 34' LT	723+69, 36' LT
717+16, 31' RT	724+60, 40' RT
717+38, 31' LT	725+50, 42' LT
718+02, 30' RT	725+85, 42' LT
718+24, 29' LT	726+10, 42' RT
718+88, 29' RT	726+50, 37' LT
719+10, 29' LT	727+98, 34' RT
719+74, 29' RT	728+36, 31' LT
719+96, 29' LT	729+90, 29' RT

INLET AND PIPE PROTECTION	
700+33, 32' LT	
702+12, 35' LT	
706+26, 43' LT	
714+16, 36' LT	
722+38, 34' RT	
725+68, 33' LT	
727+57, 37' RT	

ILLINOIS DEPARTMENT OF TRANSPORTATION
F.A.S. 1517 (U.S. ROUTE 150)
EROSION CONTROL PLAN
STA. 700+00 TO STA. 730+00

SCALE: VERT. _____
 HORIZ. _____
 DATE _____

DRAWN BY _____
 CHECKED BY _____

F.A.S. RTE.	SECTION	COUNTY	TOTAL SHEETS	SHEET NO.
1517 (2)RS-3 (3)RS-4		MCLEAN	223	88
STA.	TO STA.			
FED. ROAD DIST. NO.	ILLINOIS FED. AID PROJECT			

66383

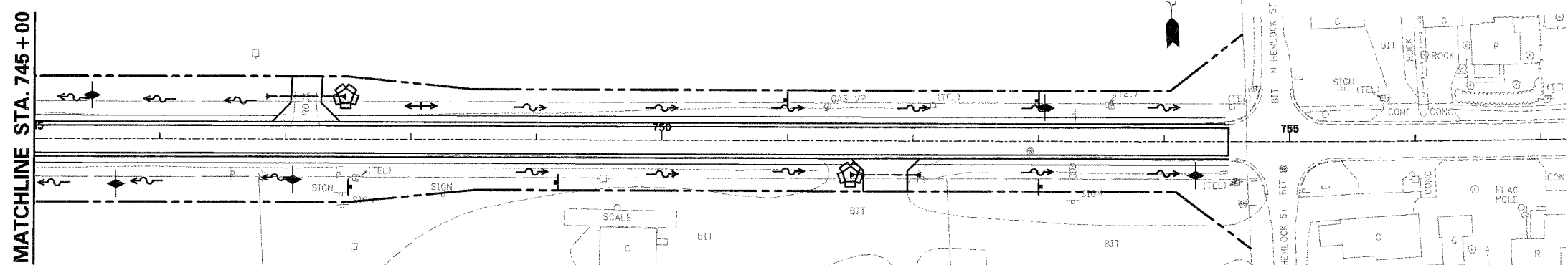
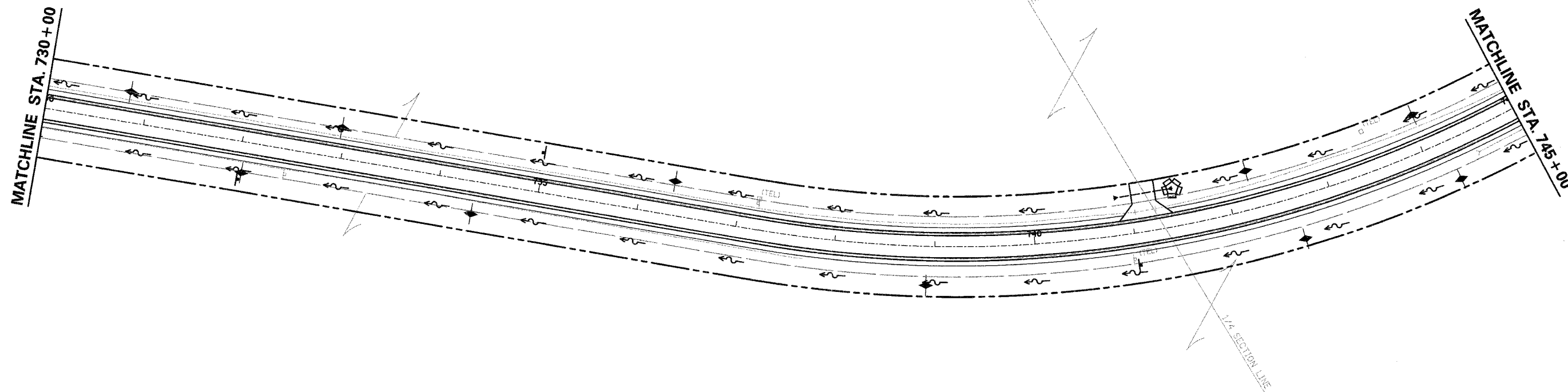
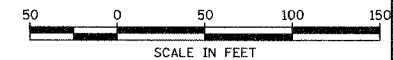

NOTE:
EROSION CONTROL BLANKET SHALL BE INSTALLED AT ALL
END SECTION LOCATIONS (SEE SCHEDULE OF QUANTITIES).

LEGEND

- PERIMETER EROSION BARRIER
- PROPOSED R.O.W.
- TEMPORARY EASEMENT
- EXISTING R.O.W.

TEMPORARY DITCH CHECKS

730+82, 31' LT	742+63, 42' RT
732+04, 31' RT	744+05, 38' LT
732+96, 31' LT	744+24, 41' RT
734+37, 32' RT	745+46, 35' LT
736+33, 34' LT	745+65, 36' RT
738+92, 39' RT	747+06, 32' RT
742+23, 39' LT	753+05, 27' LT
	754+25, 27' RT

INLET AND PIPE PROTECTION

741+45, 38' LT
747+48, 34' LT
751+50, 27' RT

ILLINOIS DEPARTMENT OF TRANSPORTATION
F.A.S. 1517 (U.S. ROUTE 150)
EROSION CONTROL PLAN
STA. 730+00 TO STA. 754+51

SCALE: VERT. _____
 DATE _____ HORIZ. _____

DRAWN BY _____
 CHECKED BY _____

PLAN

SURVEYED	BY	DATE
NOTE BOOK		
ALIGNED CHECKED		
PLANNED FILE NAME		
NO.		

PROFILE

SURVEYED	BY	DATE
GRADES CHECKED		
BLK. NOTED		
PROF. INSTRUMENTATION		
NO.		

COMPANY NAME: #COMPANY NAME#
 PROJECT CONTACT: #PROJECT CONTACT#
 CLIENT: #CLIENT#
 DATE: #DATE#
 SHEET: #SHEET#

F.A.S. RTE.	SECTION	COUNTY	TOTAL SHEETS	SHEET NO.
1517 (2)RS-3 (3)RS-4		MCLEAN	223	89
STA. _____ TO STA. _____		FED. ROAD DIST. NO. _____ ILLINOIS FED. AID PROJECT		

66383

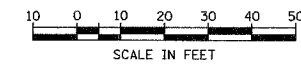

PLAN	BY	DATE
SURVEYED		
ALIGNED		
CHECKED		
DATE		
NO.		

PROFILE	BY	DATE
SURVEYED		
GRADES		
CHECKED		
DATE		
NO.		

COMPANY NAME: #COMPANY NAME#
 PROJECT CONTACT: #PROJECT CONTACT#
 CLIENT: #CLIENT#
 DATES: #DATES#
 SHEETS: #SHEETS#

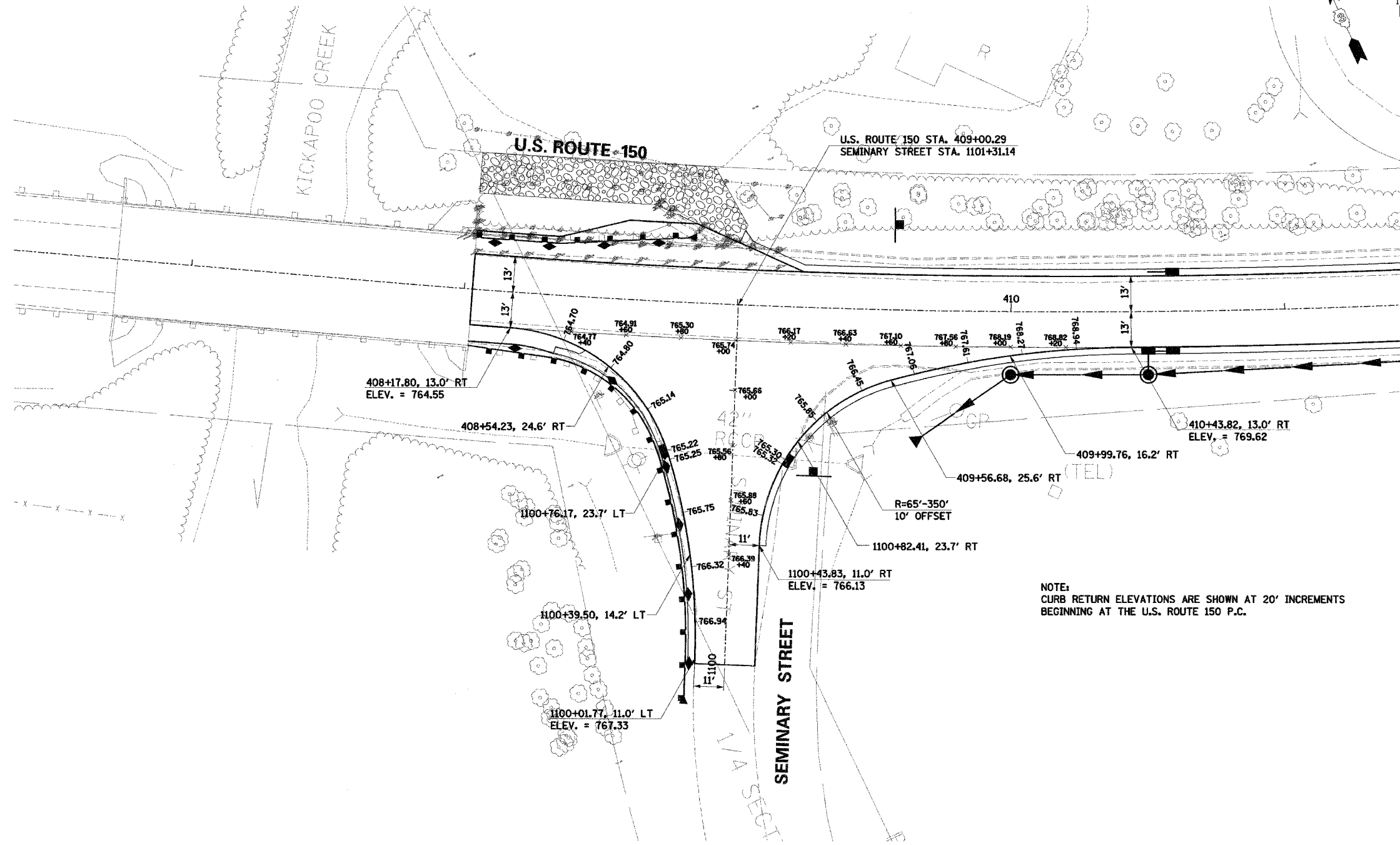

NOTE:
 CURB RETURN ELEVATIONS ARE SHOWN AT 20' INCREMENTS
 BEGINNING AT THE U.S. ROUTE 150 P.C.

ILLINOIS DEPARTMENT OF TRANSPORTATION
 F.A.S. 1517 (U.S. ROUTE 150)
 PAVEMENT ELEVATION PLAN
 SEMINARY STREET

SCALE: VERT. _____
 HORIZ. _____
 DATE _____

DRAWN BY _____
 CHECKED BY _____

F.A.S. RTE.	SECTION	COUNTY	TOTAL SHEETS	SHEET NO.
1517	2)RS-3 (3)RS-4	MCLEAN	223	90
STA. _____ TO STA. _____		ILLINOIS FED. AID PROJECT		

66383

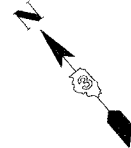
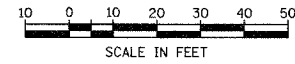

DATE	BY	REVISION

DATE	BY	REVISION

COMPANY NAME: #COMPANY#
 PROJECT CONTACT: #PROJECT_CONTACT#
 CLIENT: #CLIENT#
 DATE: #DATE#
 SHEET: #SHEET#

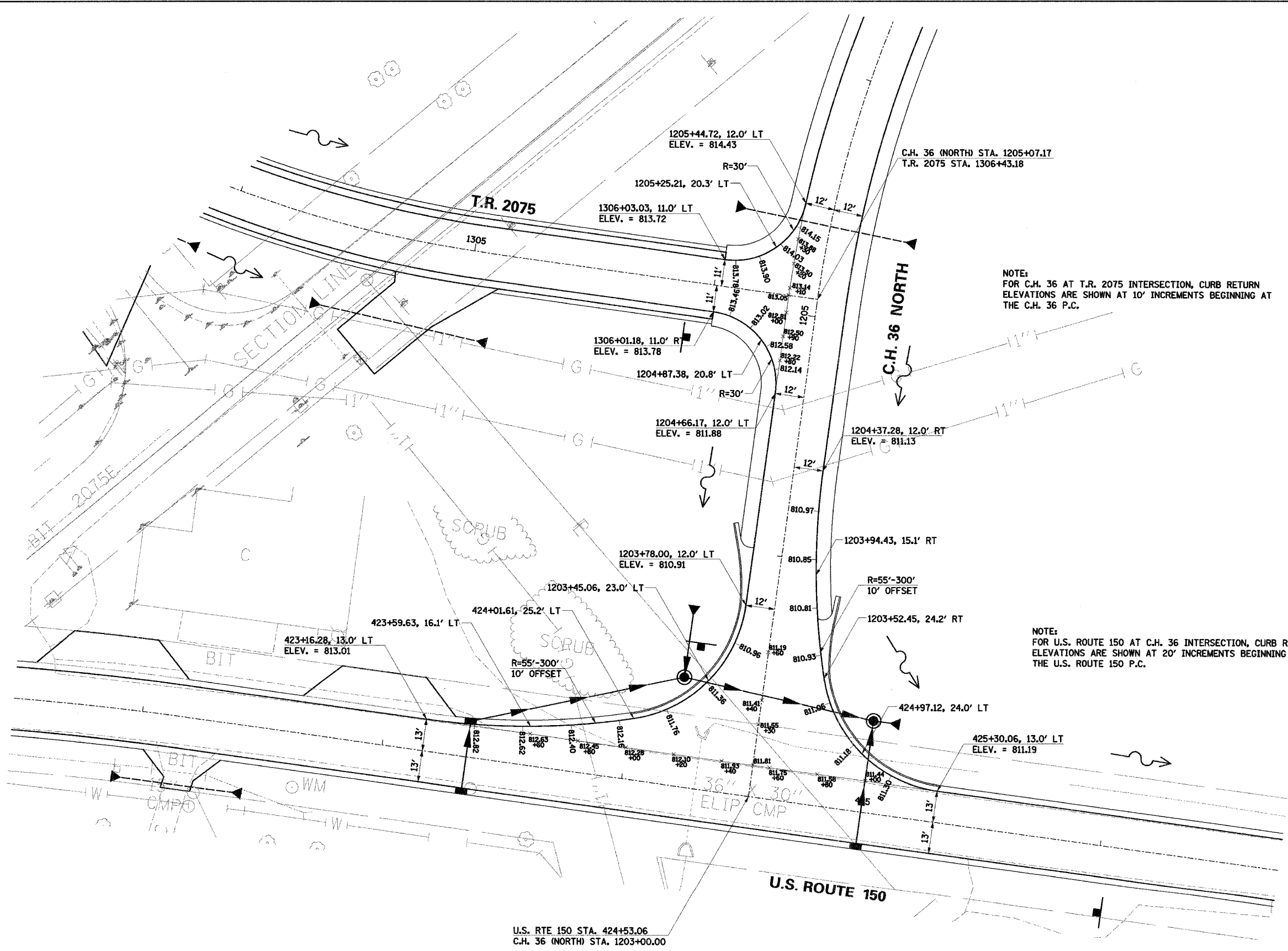

NOTE:
 FOR C.H. 36 AT T.R. 2075 INTERSECTION, CURB RETURN ELEVATIONS ARE SHOWN AT 10' INCREMENTS BEGINNING AT THE C.H. 36 P.C.

NOTE:
 FOR U.S. ROUTE 150 AT C.H. 36 INTERSECTION, CURB RETURN ELEVATIONS ARE SHOWN AT 20' INCREMENTS BEGINNING AT THE U.S. ROUTE 150 P.C.

U.S. RTE 150 STA. 424+53.06
 C.H. 36 (NORTH) STA. 1203+00.00

ILLINOIS DEPARTMENT OF TRANSPORTATION
 F.A.S. 1517 (U.S. ROUTE 150)
 PAVEMENT ELEVATION PLAN
 C.H. 36 NORTH
 T.R. 2075

SCALE: VERT. _____
 HORIZ. _____
 DATE _____

DRAWN BY _____
 CHECKED BY _____

F.A.S. RTE.	SECTION	COUNTY	TOTAL SHEETS	SHEET NO.
1517 (2)RS-3 (3)RS-4		MCLEAN	223	91
STA. _____ TO STA. _____		ILLINOIS FED. AID PROJECT		

66383

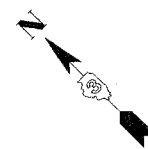
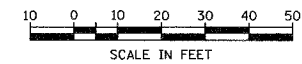

PLAN	BY	DATE
SURVEYED		
NOTE BOOK		
ALIGNED CHECKED		
DATE FILE NAME		

PROFILE	BY	DATE
SURVEYED		
CHANGES CHECKED		
STRUCTURE NOTATIONS CHECKED		

COMPANY NAME: #COMPANY_NAME#
 PROJECT CONTACT: #PROJECT_CONTACT#
 CLIENT: #CLIENT#
 #DATE# #TIME#
 #FILES#

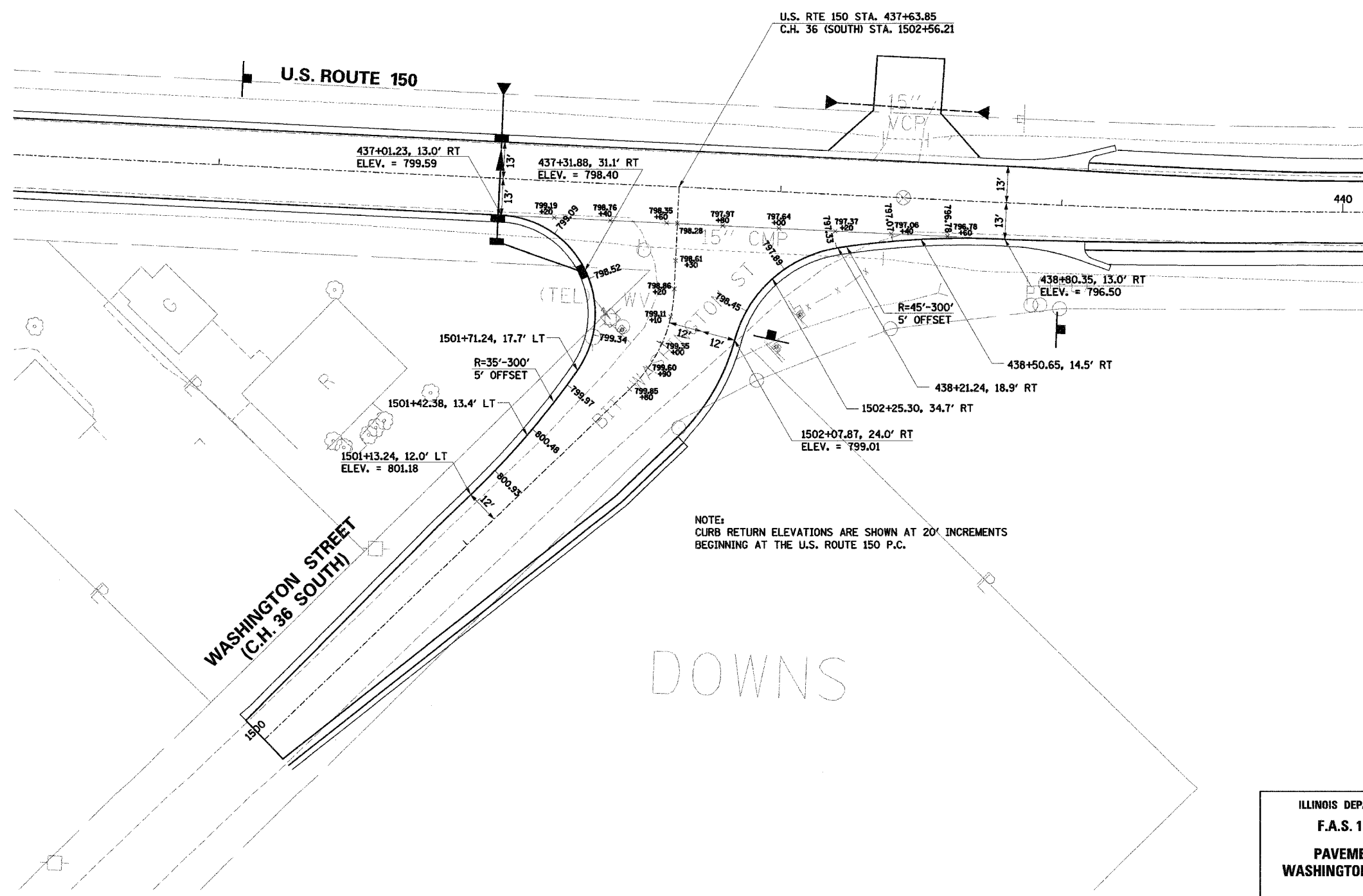

ILLINOIS DEPARTMENT OF TRANSPORTATION
 F.A.S. 1517 (U.S. ROUTE 150)
 PAVEMENT ELEVATION PLAN
 WASHINGTON STREET (C.H. 36 SOUTH)

SCALE: VERT. _____
 HORIZ. _____
 DATE _____

DRAWN BY _____
 CHECKED BY _____

F.A.S. RTE.	SECTION	COUNTY	TOTAL SHEETS	SHEET NO.
1517 (2)RS-3 (3)RS-4	MCLEAN	223	92	
STA.	TO STA.			
FED. ROAD DIST. NO. - ILLINOIS FED. AID PROJECT				

66383

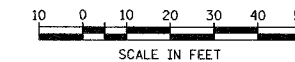

PLAN	BY	DATE
SURVEYED		
ALIGNED		
CHECKED		
BY		
NO.		

PROFILE	BY	DATE
SURVEYED		
GRADES CHECKED		
BY		
NO.		

COMPANY NAME: #COMPANY NAME#
 PROJECT CONTACT: #PROJECT CONTACT#
 CLIENT: #CLIENT#
 DATE: #DATE#
 \$FILES

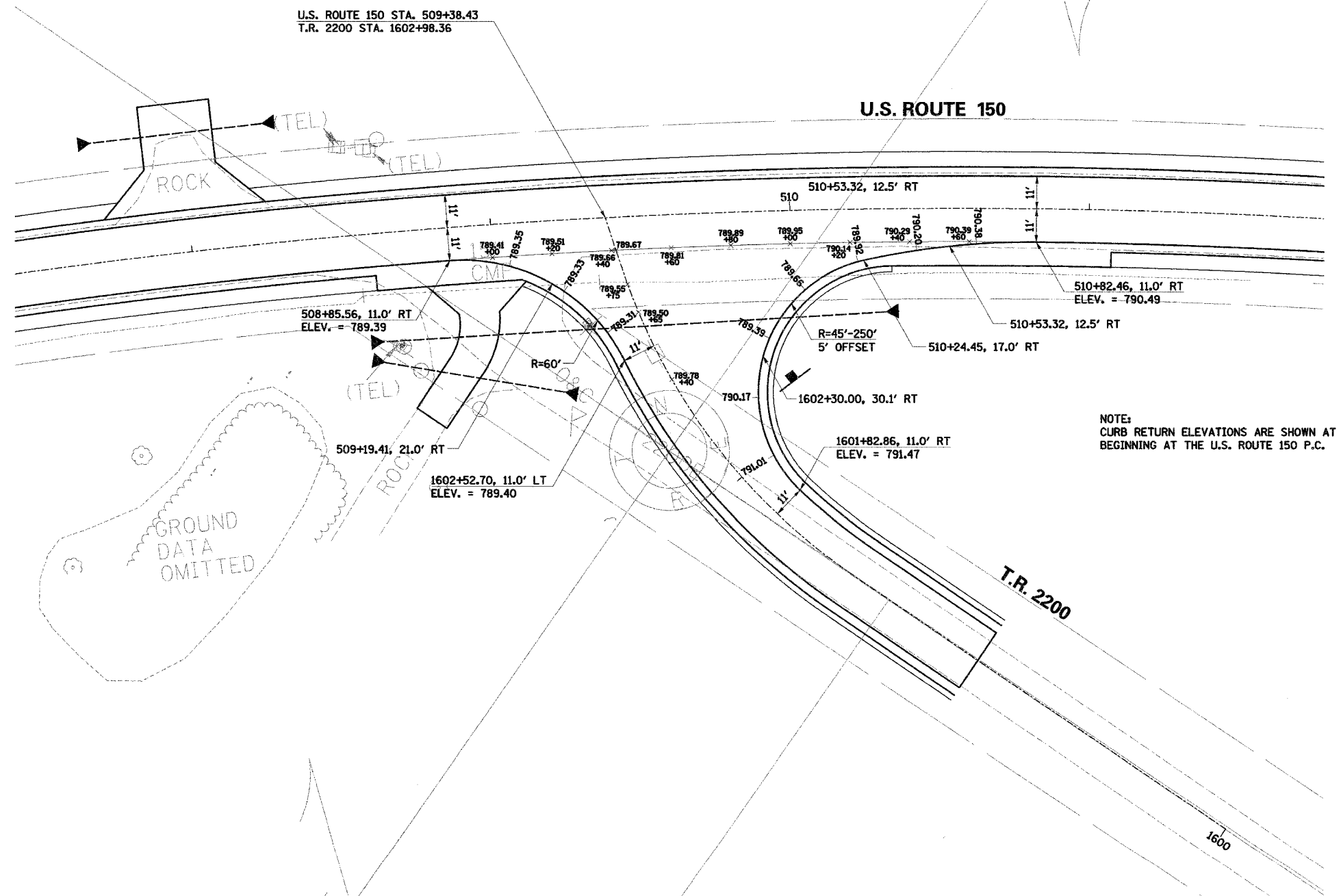

NOTE:
CURB RETURN ELEVATIONS ARE SHOWN AT 20' INCREMENTS
BEGINNING AT THE U.S. ROUTE 150 P.C.

ILLINOIS DEPARTMENT OF TRANSPORTATION
 F.A.S. 1517 (U.S. ROUTE 150)
 PAVEMENT ELEVATION PLAN
 T.R. 2200

SCALE: VERT.
HORIZ.
DATE

DRAWN BY
CHECKED BY

F.A.S. RTE.	SECTION	COUNTY	TOTAL SHEETS	SHEET NO.
1517	(2)RS-3 (3)RS-4	MCLEAN	223	93
STA. _____ TO STA. _____		ILLINOIS FED. AID PROJECT		

66383

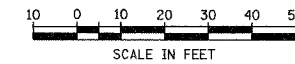

PLAN	BY	DATE
SURVEYED		
ALIGNED		
CHECKED		
PLANNED		
DESIGNED		
CONSTRUCTED		

PROFILE	BY	DATE
SURVEYED		
GRADES CHECKED		
BLANK NOTED		
STRUCTURE NOTATIONS CHECKED		

COMPANY NAME: #COMPANY/NAME#
 PROJECT CONTACT: #PROJECT/CONTACT#
 CLIENT: #CLIENT#
 DATE: #DATE#
 SHEET: #SHEET#

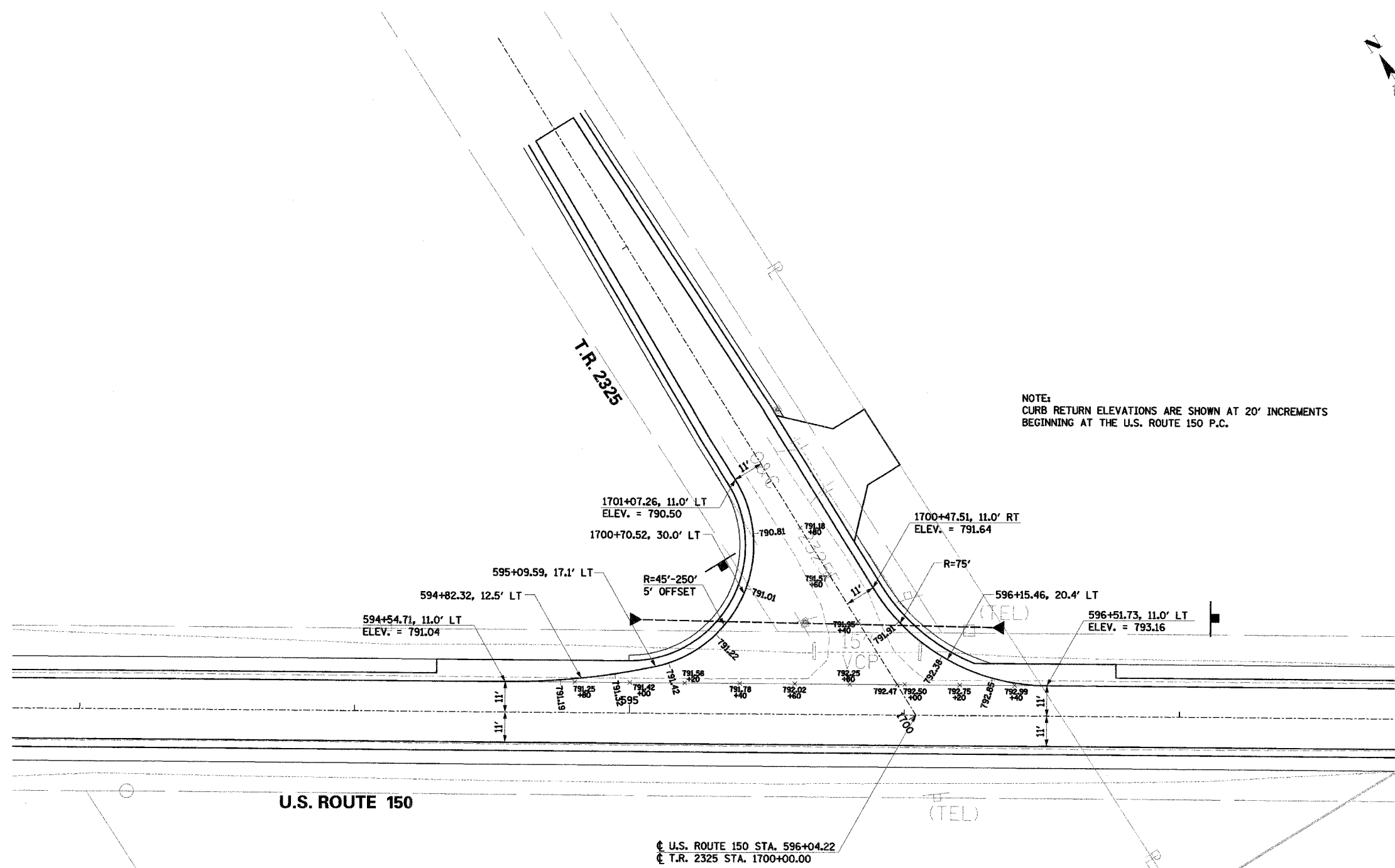

U.S. ROUTE 150

© U.S. ROUTE 150 STA. 596+04.22
 © T.R. 2325 STA. 1700+00.00

ILLINOIS DEPARTMENT OF TRANSPORTATION
 F.A.S. 1517 (U.S. ROUTE 150)
 PAVEMENT ELEVATION PLAN
 T.R. 2325

SCALE: VERT. _____
 HORIZ. _____
 DATE _____

DRAWN BY _____
 CHECKED BY _____

F.A.S. RTE.	SECTION	COUNTY	TOTAL SHEETS	SHEET NO.
1517 (2)RS-3 (3)RS-4		MCLEAN	223	94
STA. _____ TO STA. _____		ILLINOIS FED. AID PROJECT		

66383

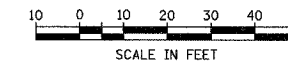

PLAN	BY	DATE
SURVEYED		
NOTE BOOK		
ALIGNED		
CHECKED		
NO.		

PROFILE	BY	DATE
SURVEYED		
GRADES CHECKED		
BLM. NOTED		
STRUCTURE NOTATIONS SHOWN		
NO.		

COMPANY NAME: #COMPANY NAME#
 PROJECT CONTACT: #PROJECT CONTACT#
 CLIENT: #CLIENT#
 #DATES# #TIME#
 #FILES#

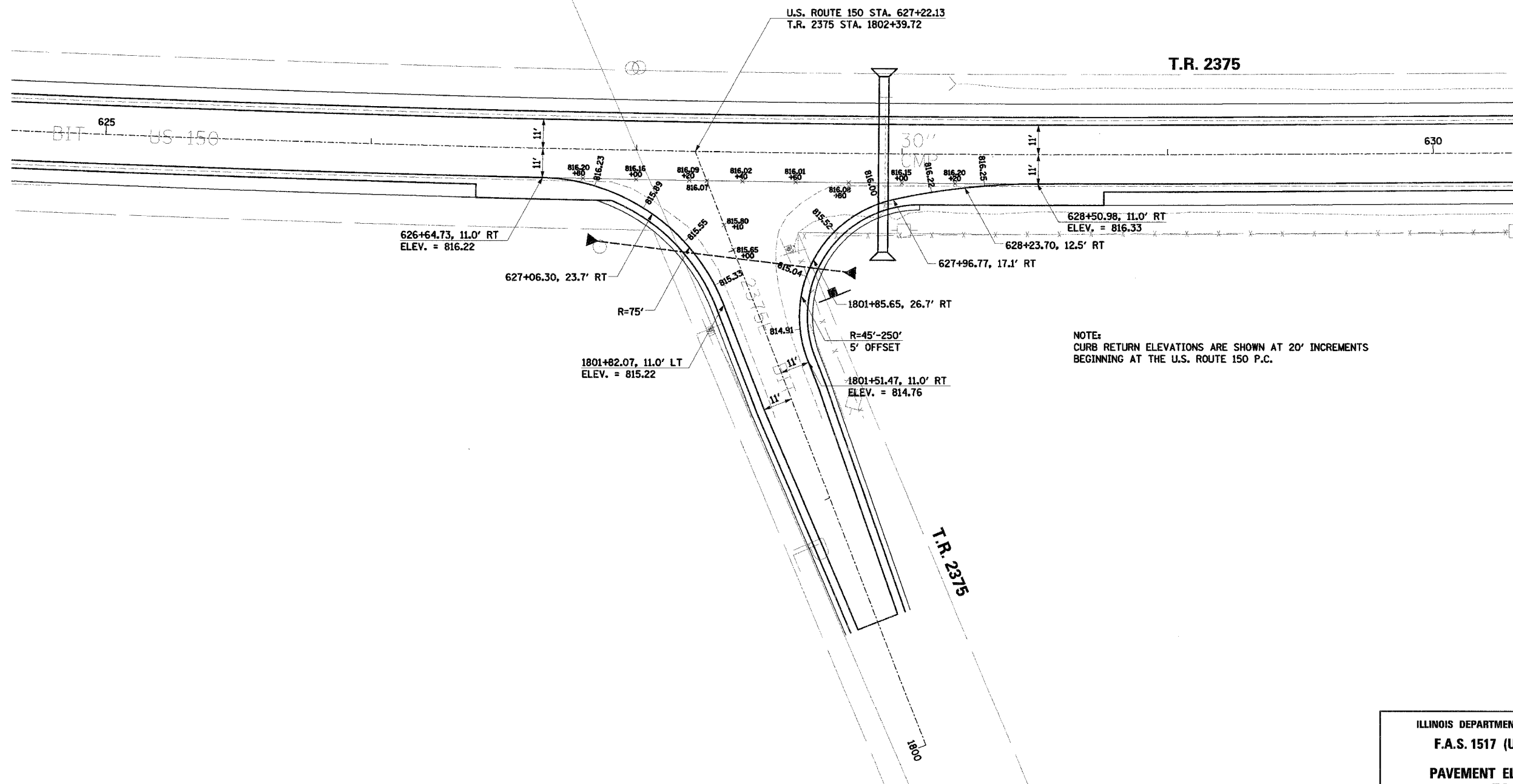

NOTE:
 CURB RETURN ELEVATIONS ARE SHOWN AT 20' INCREMENTS
 BEGINNING AT THE U.S. ROUTE 150 P.C.

ILLINOIS DEPARTMENT OF TRANSPORTATION
 F.A.S. 1517 (U.S. ROUTE 150)
 PAVEMENT ELEVATION PLAN
 T.R. 2375

SCALE: VERT. _____
 HORIZ. _____
 DATE _____

DRAWN BY _____
 CHECKED BY _____

F.A.S. RTE.	SECTION	COUNTY	TOTAL SHEETS	SHEET NO.
1517 (2)RS-3 (3)RS-4		MCLEAN	223	95
STA.	TO STA.			
FED. ROAD DIST. NO. - ILLINOIS FED. AID PROJECT				

66383

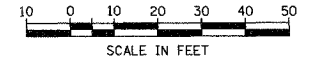

DATE	BY

DATE	BY

COMPANY NAME: #COMPANY#
 PROJECT CONTACT: #PROJECT_CONTACT#
 CLIENT: #CLIENT#
 #DATE# #TIME#
 #FILES#

NOTE:
 CURB RETURN ELEVATIONS ARE SHOWN AT 20' INCREMENTS
 BEGINNING AT THE U.S. ROUTE 150 P.C.

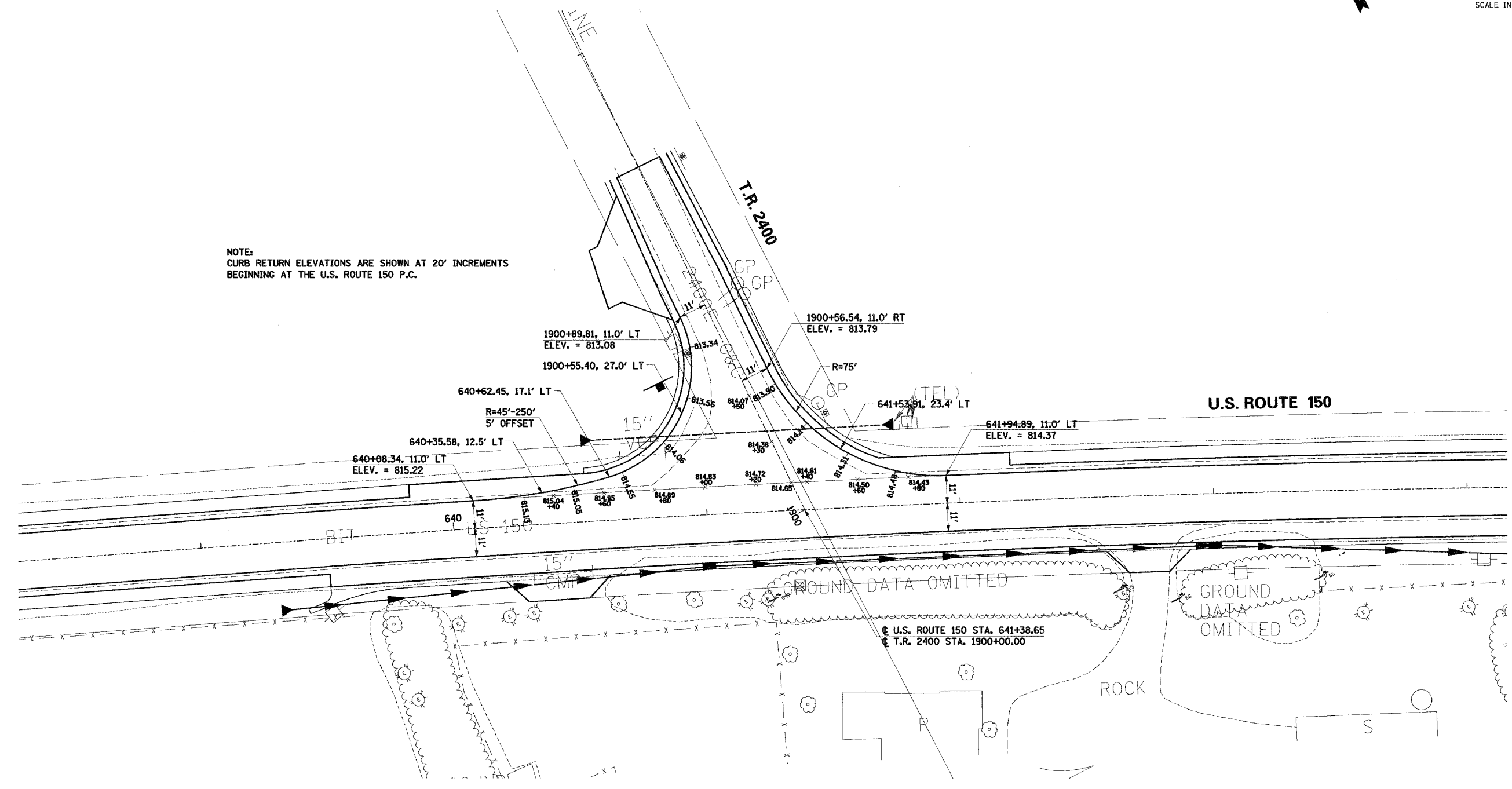

ILLINOIS DEPARTMENT OF TRANSPORTATION
 F.A.S. 1517 (U.S. ROUTE 150)
 PAVEMENT ELEVATION PLAN
 T.R. 2400

SCALE: VERT. _____
 HORIZ. _____
 DATE _____

DRAWN BY _____
 CHECKED BY _____

F.A.S. RTE.	SECTION	COUNTY	TOTAL SHEETS	SHEET NO.
1517 (2)RS-3 (3)RS-4		MCLEAN	223	96
STA. _____ TO STA. _____		ILLINOIS FED. AID PROJECT		

66383

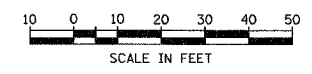

PLAN	DATE
SURVEYED _____	_____
ALIGNED _____	_____
CHECKED _____	_____
BY _____	_____
NO. _____	_____

PROFILE	DATE
SURVEYED _____	_____
FRAMES CHECKED _____	_____
BY _____	_____
NO. _____	_____

COMPANY NAME: #COMPANY NAME#
 PROJECT CONTACT: #PROJECT CONTACT#
 CLIENT: #CLIENT#
 DATE: #DATE#
 FILE#

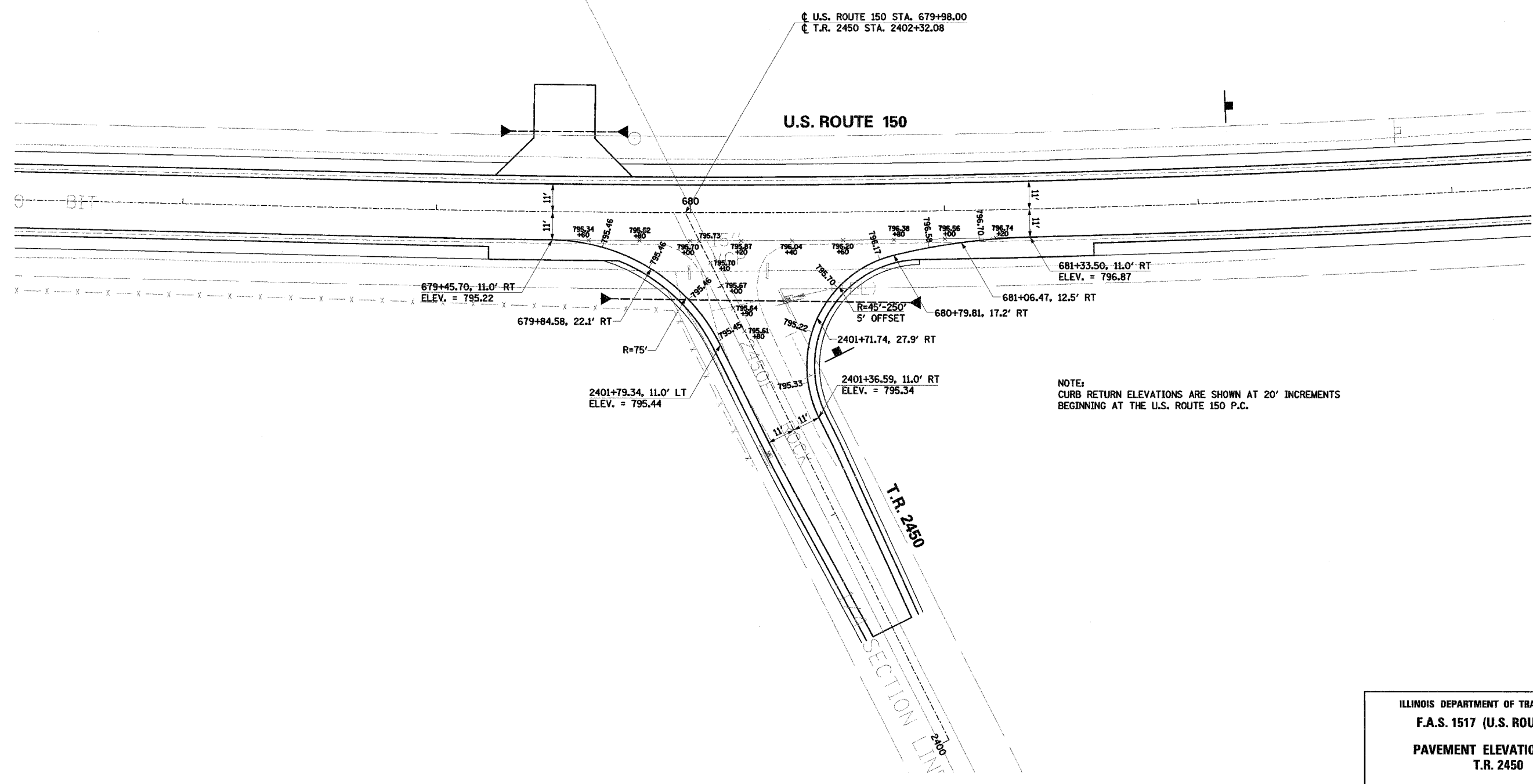

DATE _____
 BY _____
 SURVEYED _____
 PLAN NOTE BOOK _____
 ALIGNED _____
 CHECKED _____
 NO. _____
 DATE _____
 BY _____
 SURVEYED _____
 PROFILE NOTE BOOK _____
 GRADES CHECKED _____
 NO. _____
 DATE _____
 BY _____
 SURVEYED _____
 PROFILE NOTE BOOK _____
 GRADES CHECKED _____
 NO. _____

DATE _____
 BY _____
 SURVEYED _____
 PROFILE NOTE BOOK _____
 GRADES CHECKED _____
 NO. _____
 DATE _____
 BY _____
 SURVEYED _____
 PROFILE NOTE BOOK _____
 GRADES CHECKED _____
 NO. _____

COMPANY NAME: #COMPANY/NAME#
 PROJECT CONTACT: #PROJECT/CONTACT#
 CLIENT: #CLIENT#
 DATE: #DATE#
 SHEET: #SHEET#

F.A.S. RTE.	SECTION	COUNTY	TOTAL SHEETS	SHEET NO.
1517 (2)RS-3 (3)RS-4		MCLEAN	223	97
STA. _____	TO STA. _____			
FED. ROAD DIST. NO. _____ ILLINOIS FED. AID PROJECT				

66383

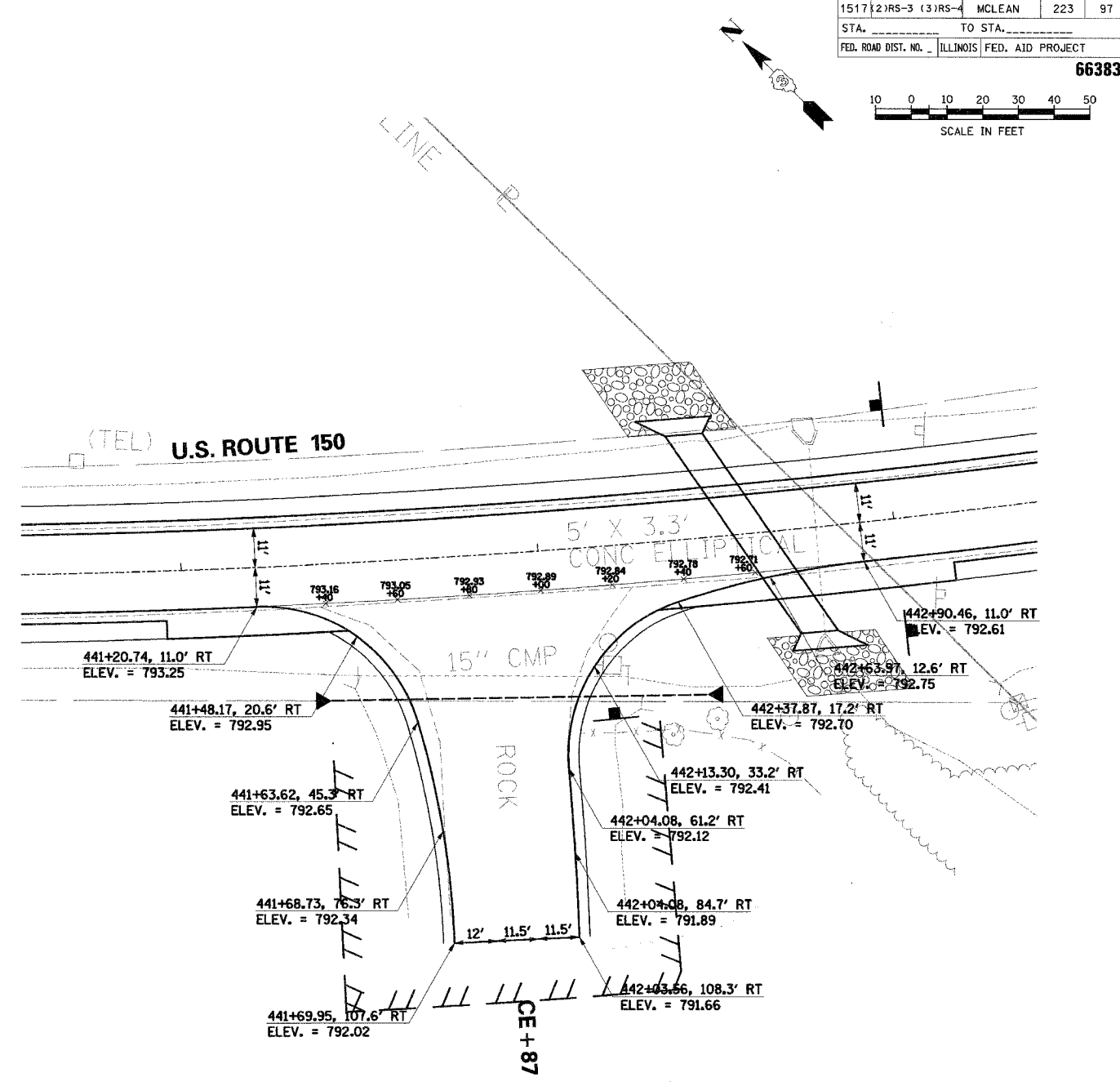
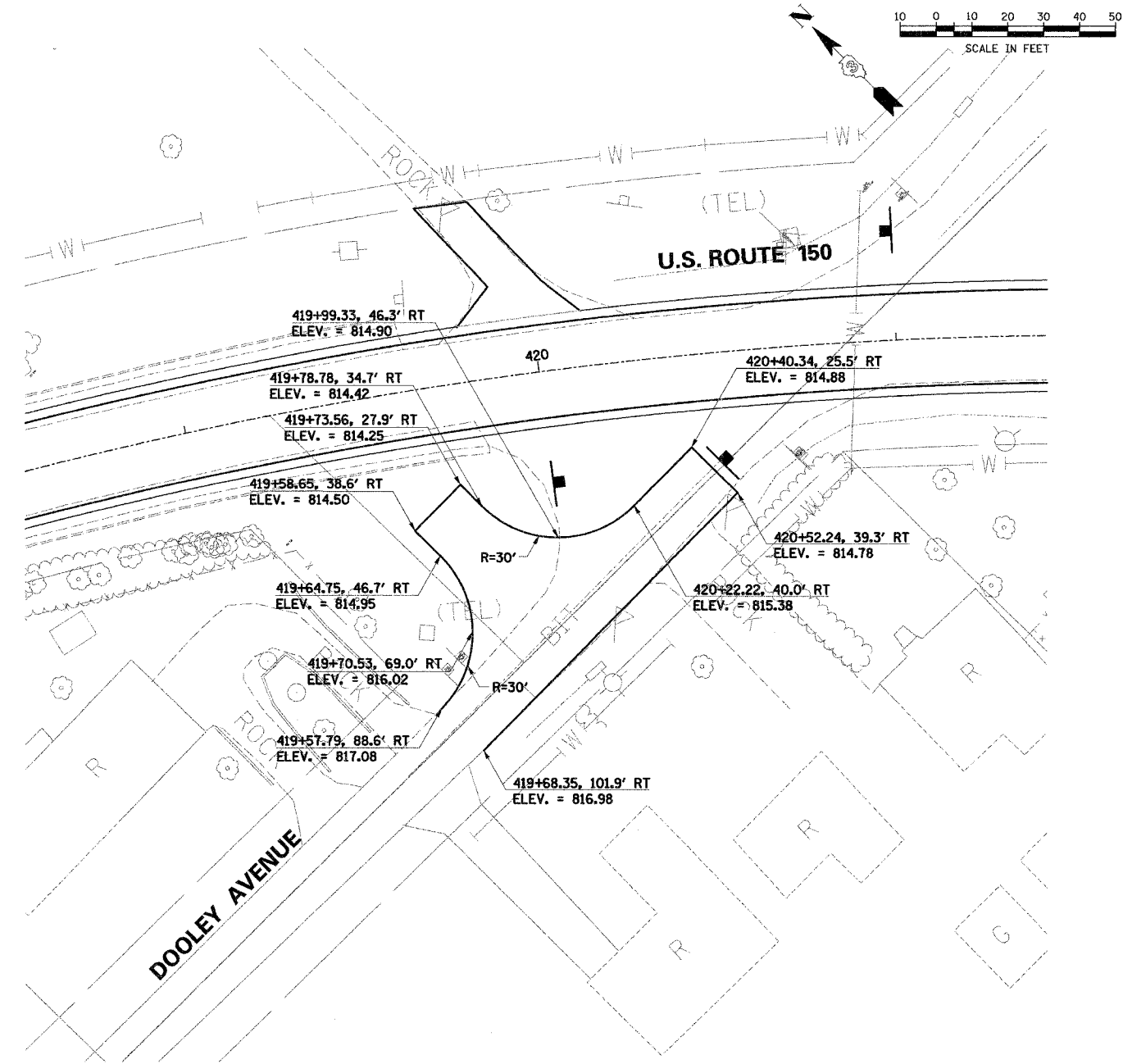

ILLINOIS DEPARTMENT OF TRANSPORTATION
 F.A.S. 1517 (U.S. ROUTE 150)
 PAVEMENT ELEVATION PLAN
 TURNABOUT (DOOLEY AVENUE)
 SCHOOL ENTRANCE

SCALE: VERT. _____
 HORIZ. _____
 DATE _____

DRAWN BY _____
 CHECKED BY _____

Bench Mark: Chiseled square West end of north cross road culvert headwall
Sta. 442+74.22, 23.85' Lt., Elev. 791.16

Existing Structure: No Structure Number. Existing Structure is a 5'x3.3' Concrete Elliptical Pipe at Sta. 442+78. The box culvert work shall be accomplished under traffic with at least one lane open during work periods and both lanes open when the Contractor is not working (see special provisions).

ROUTE NO.	SECTION	COUNTY	TOTAL SHEETS	SHEET NO.	SHEET NO. 1
1517	(2)RS-3 (3)RS-4	MCLEAN	223	98	3 SHEETS
FED. ROAD DIST. NO. 7 ILLINOIS FED. AID PROJECT					

GENERAL NOTES

- See Roadway Plans for Erosion Control and Porous Granular Bedding Layout.
- Cast-In-Place Concrete Exposed Edges Shall Be Beveled $\frac{3}{4}$ ".
- Class SI Concrete Shall Be Used Throughout the cast-in-place end sections.
- Reinforcement Bars Shall Conform To The Requirements of AASHTO M-31 or M-322, Grade 60.
- It Shall Be The Responsibility Of The Contractor To Divert The Stream Flow During Construction In Order To Keep The Construction Area Free Of Water. The Method Of Water Diversion Shall Be Subject To The Approval Of The Engineer And The Cost Shall Be Included With The Cost of "Concrete Box Culverts"
- Structural Seal Is For Cast-In-Place Portion Of Structure Only.
- For Backfilling And Embankment, See Special Provisions.
- Outside End of Precast Sections Shall Not Have A Bell Or Spigot.
- Precast Concrete Box Culvert sections shall conform to the requirements of Article 540.06 of the Standard Specifications and the applicable requirements of AASHTO M 273 (ASTM C850).
- Lifting holes shall be filled with concrete plugs and mastic after box sections are in place.
- Cast-in-Place End Sections shall be paid for as Concrete Box Culverts.
- Smooth transitions shall be graded between the ends of the culvert and the normal foreslope.

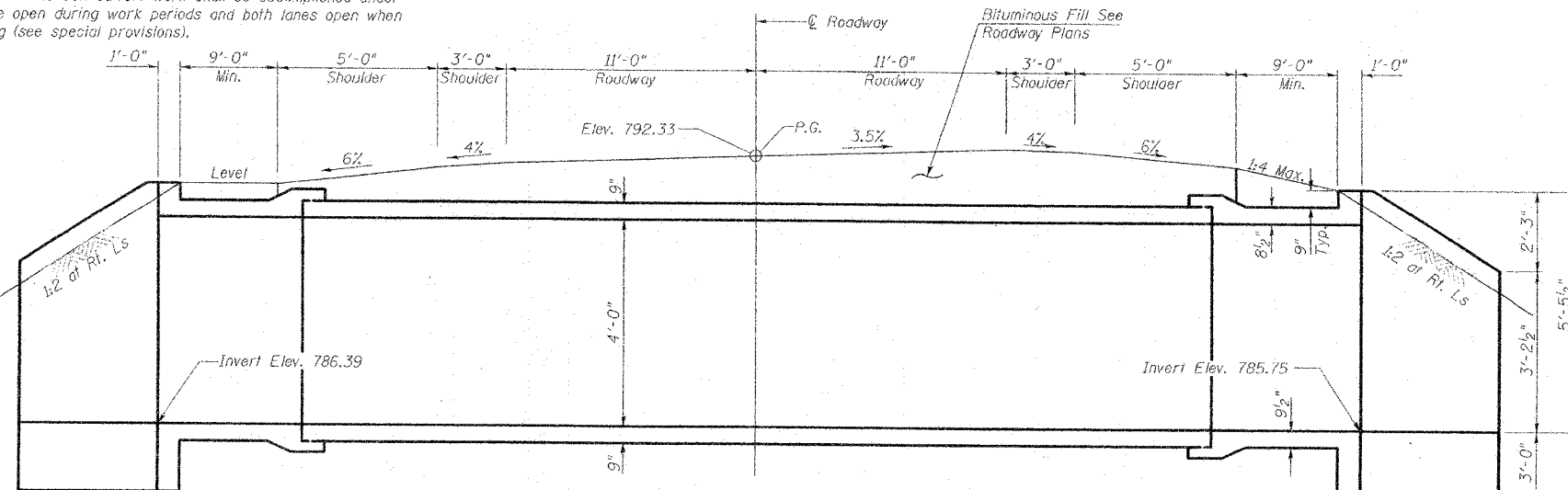

LONGITUDINAL SECTION
(Dim. at right angles to Roadway)

TOTAL BILL OF MATERIAL

ITEM	UNIT	TOTAL
Remove Existing Culverts	Each	1
Concrete Box Culverts	Cu Yd	23.9
Reinforcement Bars	Pound	5310
Precast Concrete Box Culvert 9' x 4'	Foot	48

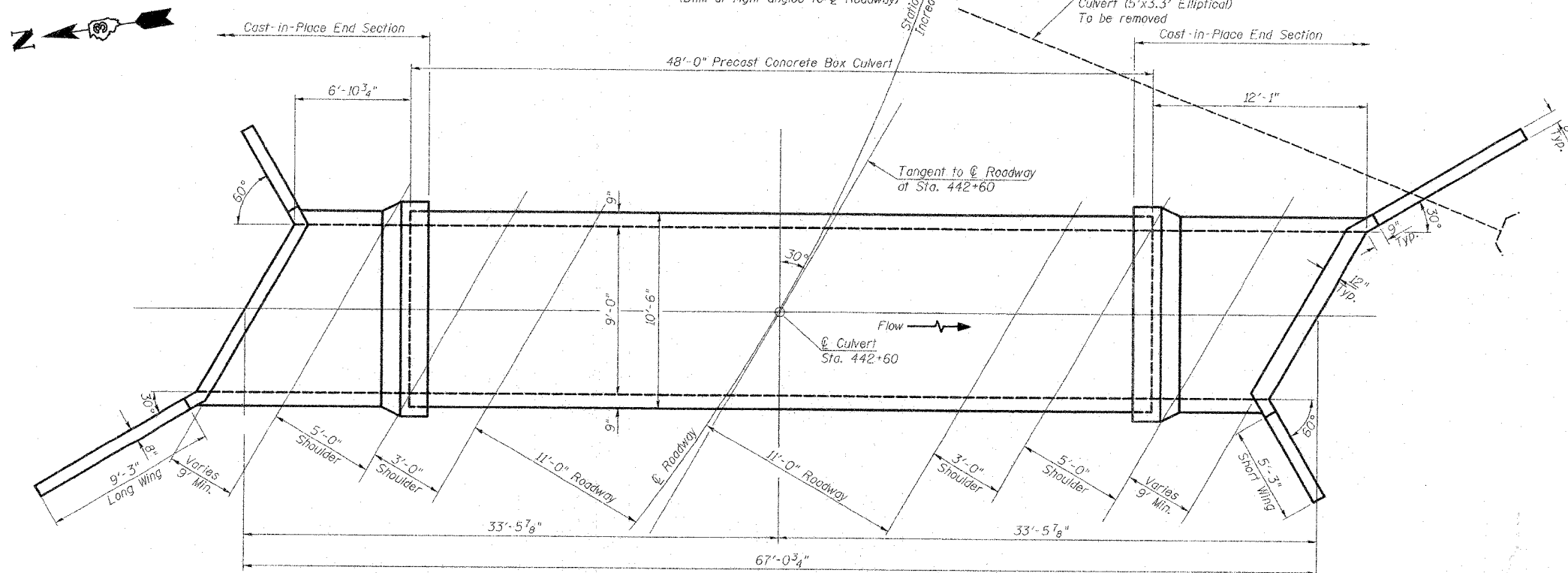

PLAN

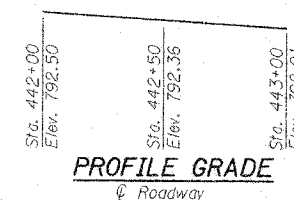

PROFILE GRADE
Roadway

WATERWAY INFORMATION

Flood		Opening Sq. Ft.		Head Ft.		Headwater E.L.			
Freq. Yr.	C.F.S.	Exist.	Prop.	H.W.E. Exist.	Prop.	Exist.	Prop.		
Design	50	248	13	20.7	788.65	3.55	2.35	792.2	791.0
Base	100	282	13	22.5	788.89	3.41	2.61	792.3	791.5
Overtopping	-	-	-	-	-	-	-	-	-
Max. Calc.	500	-	-	-	-	-	-	-	-

DESIGN STRESSES

FIELD UNITS
 $f'_c = 3,500$ psi
 $f_y = 60,000$ psi (reinforcement)

PRECAST UNITS
 $f'_c = 5,000$ psi
 $f_y = 60,000$ psi (Welded Wire Fabric)

LOADING HS20-44

Allow 50#/sq. ft. for future wearing surface.

DESIGN SPECIFICATIONS

2002 AASHTO

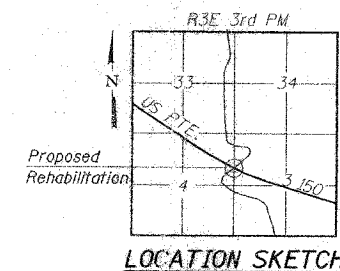

LOCATION SKETCH

ILLINOIS DEPARTMENT OF TRANSPORTATION

SHEET TITLE: **CULVERT PLAN**

PROJECT: **FAS ROUTE 1517 SECTION (2)RS-3 (3)RS-4 MCLEAN COUNTY STATION 442+60**

PROJECT NO. 03064
 DATE 5/19/05
 DRAWN BY TFG
 CHECKED BY CME/REG/MCB
 DRAWING NO. 1

COOMBE-BLOXDORF P.C.
 Engineers / Land Surveyors
 Springfield, Illinois
 Design Firm License No. 184-002703

OF 2 SHTS

ROUTE NO.	SECTION	COUNTY	TOTAL SHEETS	SHEET NO.	SHEET NO.
1517	(2)RS-3 (3)RS-4	MCLEAN	223	99	3 SHEETS
FED. ROAD DIST. NO. 7 ILLINOIS FED. AID PROJECT					

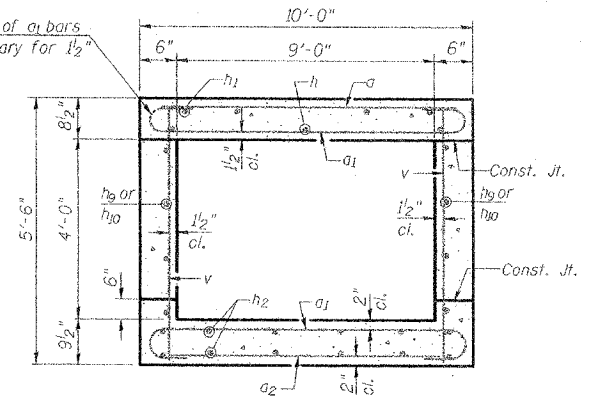
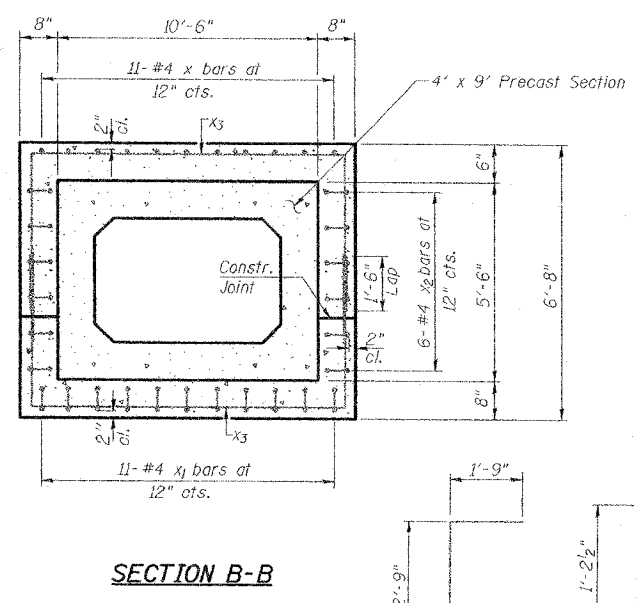
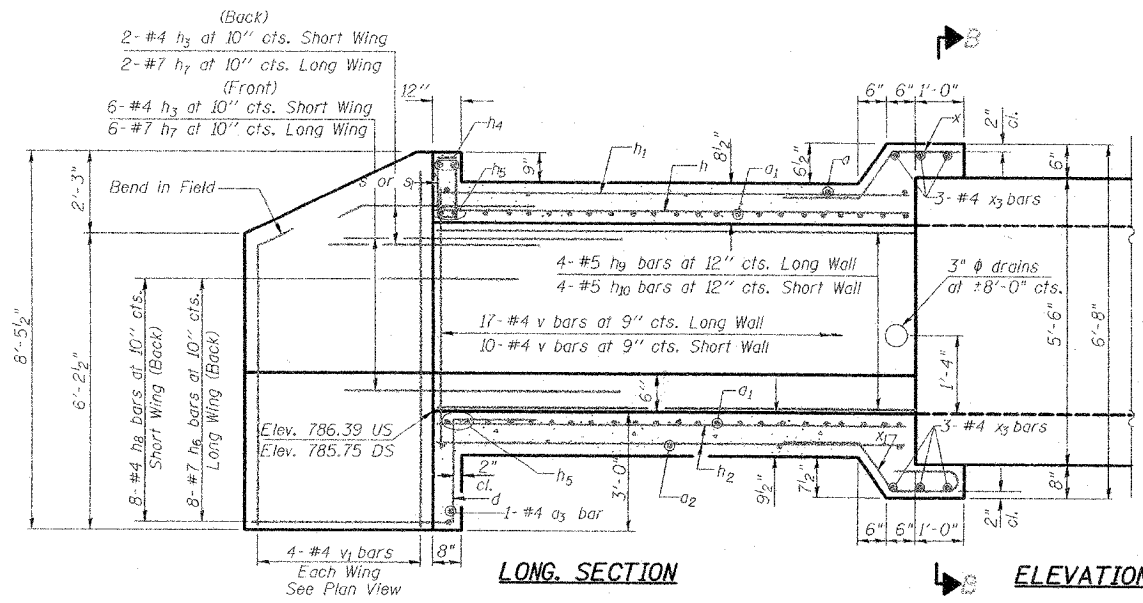

SECTION THRU CAST-IN-PLACE BARREL

BILL OF MATERIAL

Bar	No.	Size	Length	Shape
a	14	#5	9'-8"	—
a1	70	#8	11'-6"	—
a2	11	#4	9'-3"	—
a3	2	#4	10'-7"	—
d	18	#4	4'-6"	—
h	10	#7	18'-4"	—
h1	10	#4	18'-4"	—
h2	16	#5	18'-4"	—
h3	16	#4	8'-0"	—
h4	4	#6	10'-2"	—
h5	8	#8	11'-2"	—
h6	16	#7	12'-9"	—
h7	16	#7	8'-0"	—
h8	16	#4	8'-9"	—
h9	8	#5	11'-9"	—
h10	8	#5	6'-7"	—
v	58	#4	5'-2"	—
v1	16	#4	13'-2"	—
s	11	#4	4'-8"	—
s1	11	#4	4'-6"	—
x	22	#4	3'-6"	—
x1	22	#4	4'-11"	—
x2	24	#4	5'-1"	—
x3	12	#4	10'-5"	—
Concrete Box Culverts			Cu. Yd.	23.9
Reinforcement Bars			Pound	5310

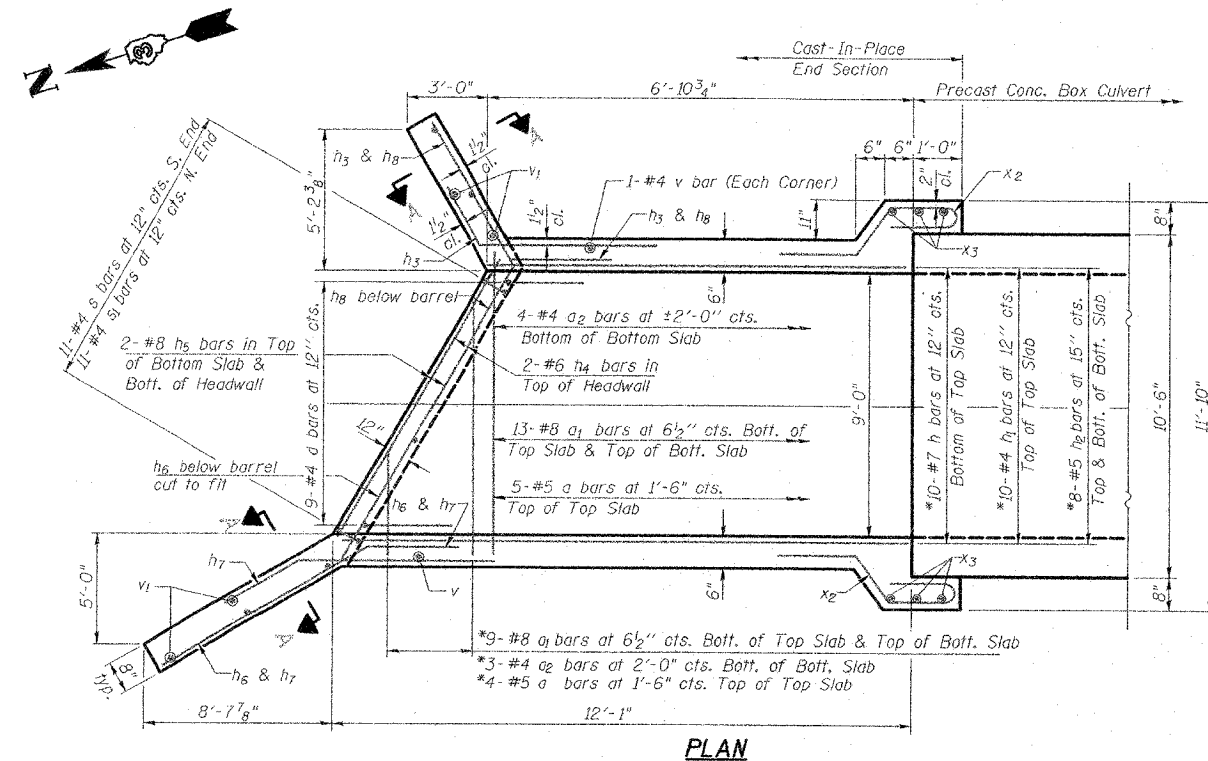

PLAN (North end shown, South end similar by rotating 180°)

NOTES

A distance of half the length of the wingwall but not less than six feet of the barrel shall be poured monolithically with the wingwalls. All construction joints shall be bonded.

*Bars shall be ordered full length & cut to fit skew. Balance of bar to be used in opposite end of culvert.

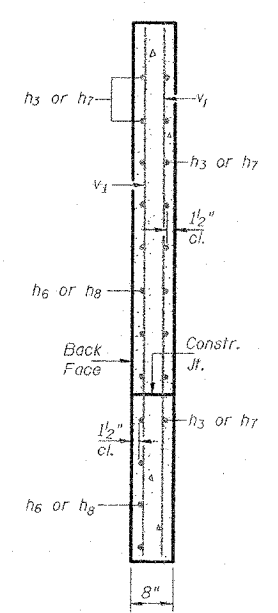

SECTION A-A SECTION THRU HEADWALL (Up Stream End Only)

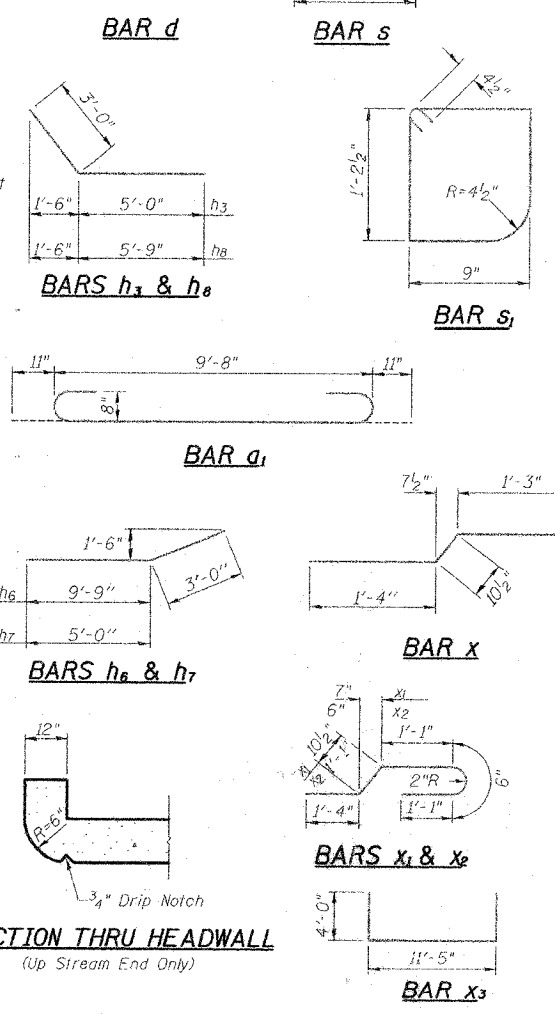

ILLINOIS DEPARTMENT OF TRANSPORTATION	
SHEET TITLE: CULVERT DETAILS	
PROJECT: FAS ROUTE 1517 SECTION (2)RS-3 (3)RS-4 MCLEAN COUNTY STATION 442+60	PROJECT NO. 03064
SCALE: 5/18/05	DATE: 5/18/05
DRAWN BY: TFC	CHECKED BY: CME/REG/MCB
DESIGNED BY: TFC	DRAWING NO. 2
COOMBE-BLOXDORF P.C. Engineers / Land Surveyors Springfield, Illinois	Design Firm License No. 184-002703
	OF 2 SH15

F.A.S. RTE.	SECTION	COUNTY	TOTAL SHEETS	SHEET NO.
1517 (2)RS-3 (3)RS-4		MCLEAN	223	100
STA.	TO STA.			
FED. ROAD DIST. NO.	ILLINOIS FED. AID PROJECT			

66383

- NOTES:
1. USE 16 GAUGE STEEL FOR CABINET.
 2. THE TOP SHELF SHALL SLIDE IN OR OUT WITH THE TOP DOOR OPEN.
 3. ALL HINGES AND HASPS WILL BE WELDED TO THE CABINET.
 4. ALL EDGES SHALL BE GROUND SMOOTH.
 5. TWO (2" DIA.) ACCESS HOLES WILL BE REQUIRED FOR EACH SHELF.
 6. CABINET SHALL BE PAINTED WITH TWO COATS OF FLAT PAINT.
 7. 2 EACH MATCHING KEY PADLOCKS, WITH 3 KEYS PROVIDED, MASTER MODEL 3 T OR EQUIVALENT.
 8. 4 EACH PLAIN STEEL, NON-REMOVABLE PIN, NO HOLE 4"X4" SQUARE CORNER HINGES TO BE WELDED ON.
 9. 2 EACH EXTRA HEAVY, PLAIN STEEL, FIXED STAPLE, NO HOLE, 7 1/4 " HASPS TO BE WELDED ON.

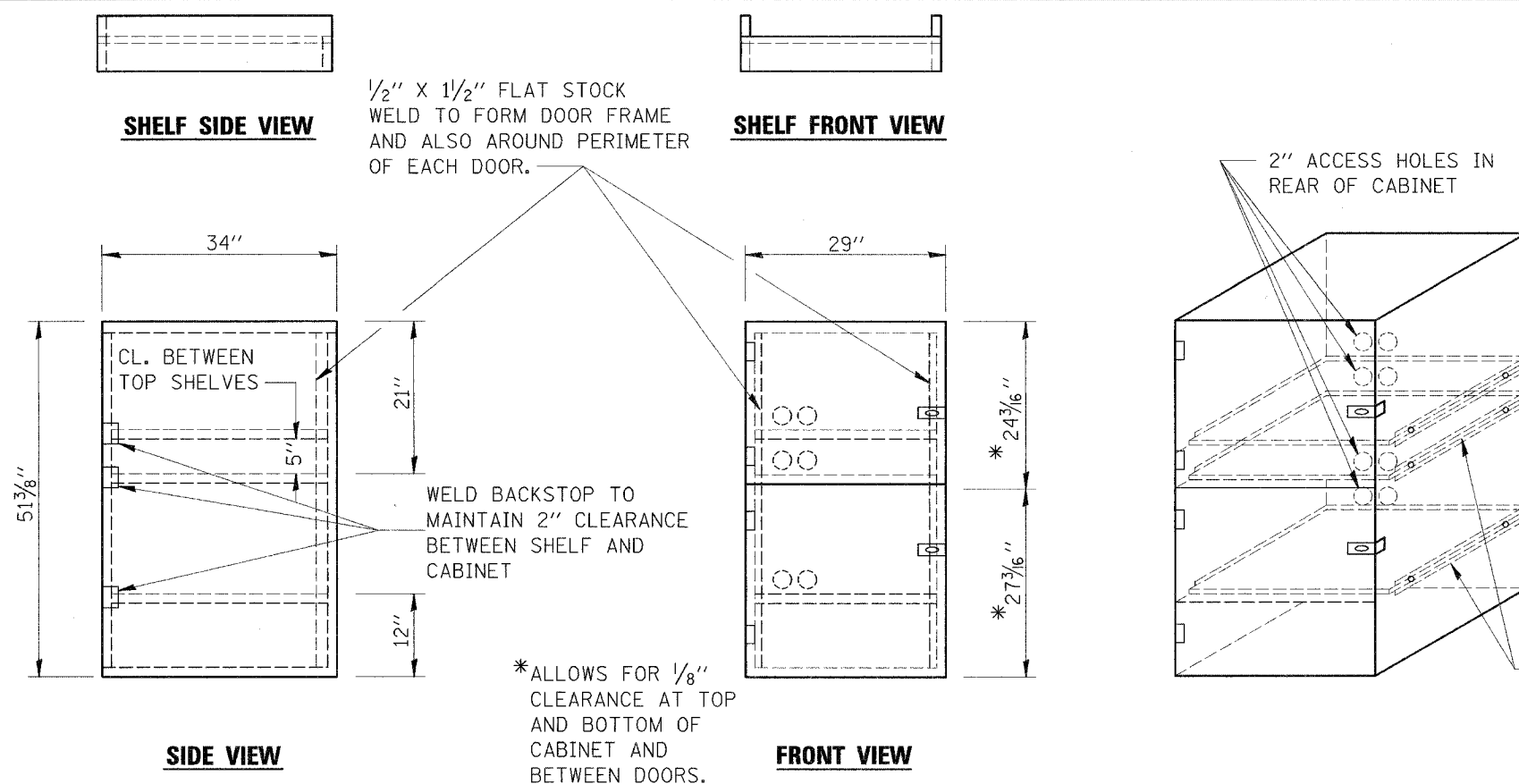

LOCKABLE COMPUTER CABINET

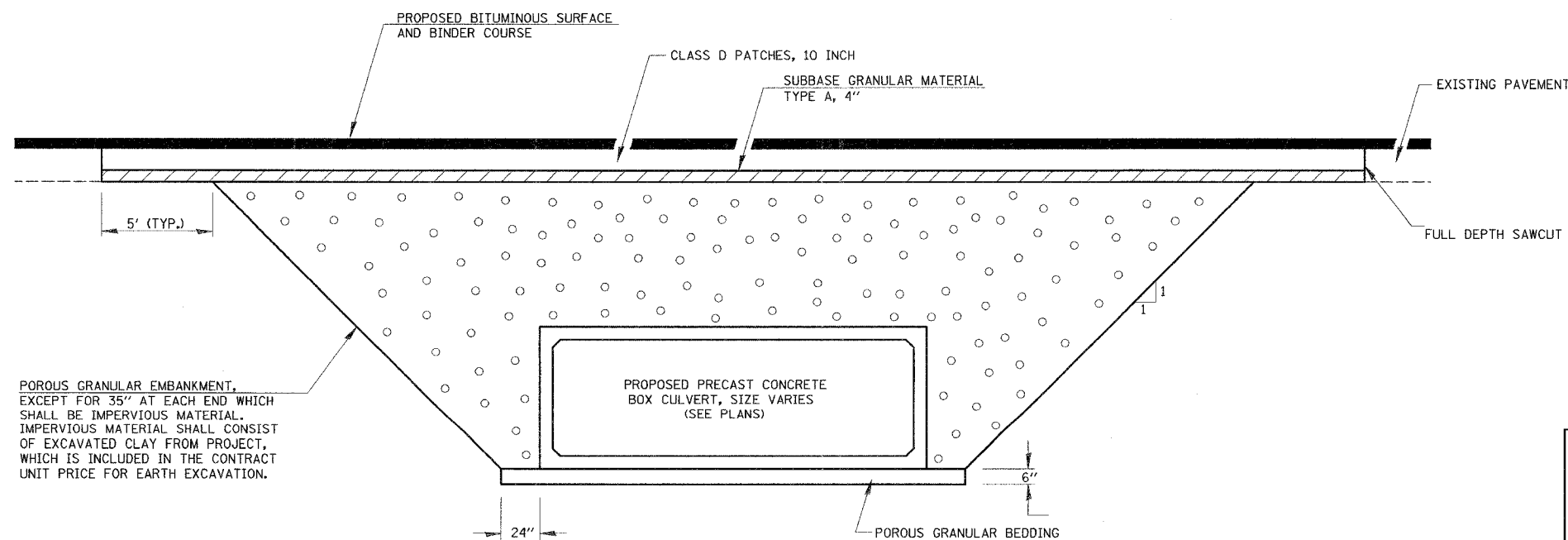

SECTION THROUGH PRECAST BOX CULVERT

ILLINOIS DEPARTMENT OF TRANSPORTATION
F.A.S. 1517 (U.S. ROUTE 150)
MISCELLANEOUS DETAILS

SCALE: VERT. _____
 HORIZ. _____
 DATE _____

DRAWN BY _____
 CHECKED BY _____

DATE _____
 BY _____
 SURVEYED _____
 PLAN _____
 NOTE BOOK _____
 NO. _____

DATE _____
 BY _____
 SURVEYED _____
 PROFILE _____
 NOTE BOOK _____
 NO. _____

COMPANY NAME: #COMPANY/NAME#
 PROJECT CONTACT: #PROJECT/CONTACT#
 CLIENT: #CLIENT#
 #DATE# #TIME#
 #FILE#