

## DETAIL OF PRECAST CONCRETE BOX CULVERT END SECTION

### GENERAL NOTES

SHOP PLANS FOR THE REINFORCEMENT SHALL BE SUBMITTED IN ACCORDANCE WITH THE REQUIREMENTS OF ARTICLE 504.04 (A) OF THE STANDARD SPECIFICATIONS.

MINIMUM CONCRETE STRENGTH SHALL BE 5000 PSI AFTER 28 DAYS.

THE JOINTS OF THE PRECAST BOX SECTIONS SHALL BE SEALED WITH MASTIC IN ACCORDANCE WITH ARTICLE 755.01 OF THE STANDARD SPECIFICATIONS FOR ROAD AND BRIDGE CONSTRUCTION.

THE TERMS AS1, AS2, AS3 AND AS4 DENOTES THE REQUIRED STEEL AREAS FOR REINFORCEMENTS AS SPECIFIED IN ASTM C 789. REINFORCEMENT SHALL BE WELDED WIRE FABRIC CONFORMING TO ASTM SPECIFICATIONS A 185.

DATE	
BY	
PLANNED	
DESIGNED	
CHECKED	
APPROVED	

END CONNECTION TO FIT PRECAST BOX CULVERT (BELL OR SPIGOT MAY BE OMITTED WHEN COLLARING TO AN EXISTING BOX TO HEADWALL)

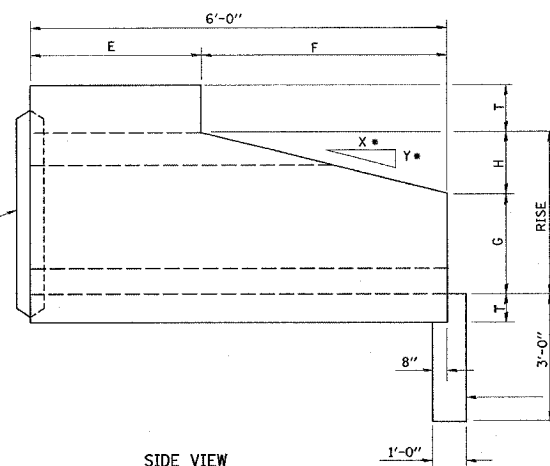

SIDE VIEW

• 2:1 SLOPE MINIMUM

PRECAST OR FIELD Poured TOEWALL

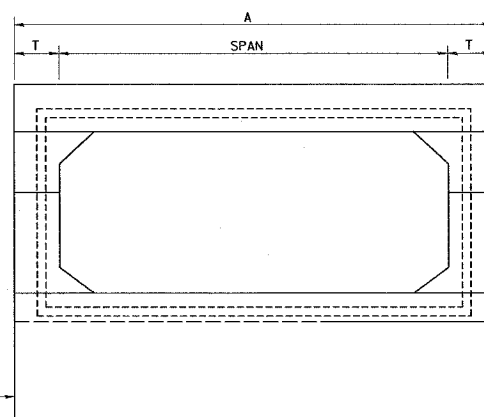

END VIEW

• NOTE: THE DIMENSIONS INDICATED ARE FOR END SECTIONS THAT ARE TO BE USED WITH PRECAST BOX CULVERT SECTIONS DESIGNED FOR 2' OR MORE OF FILL. THE DIMENSIONS MUST BE MODIFIED FOR THE END SECTION TO BE COMPATIBLE WITH PRECAST CULVERT SECTIONS DESIGNED FOR LESS THAN 2' OF FILL.

END CONNECTION TO FIT PRECAST BOX CULVERT (BELL OR SPIGOT MAY BE OMITTED WHEN COLLARING TO AN EXISTING BOX TO HEADWALL)

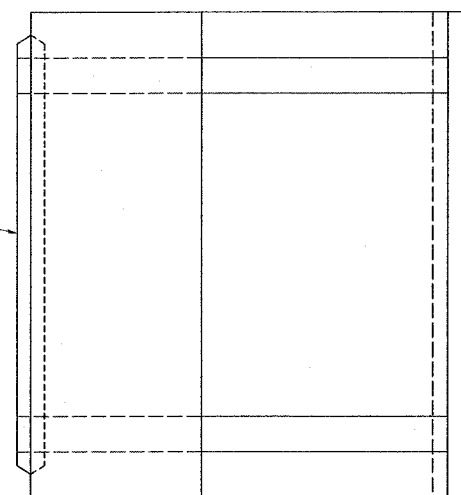

PLAN

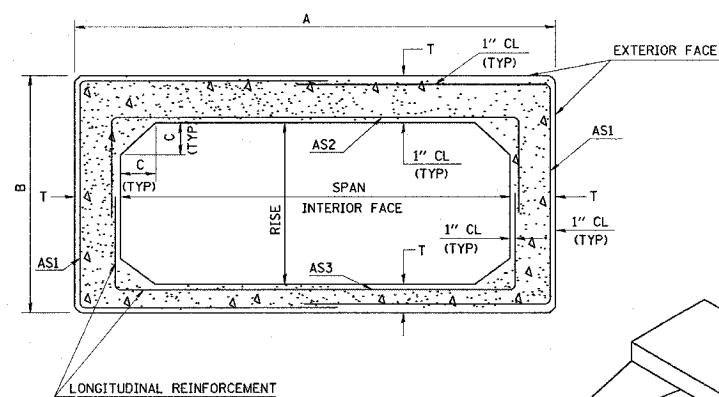

CROSS-SECTION

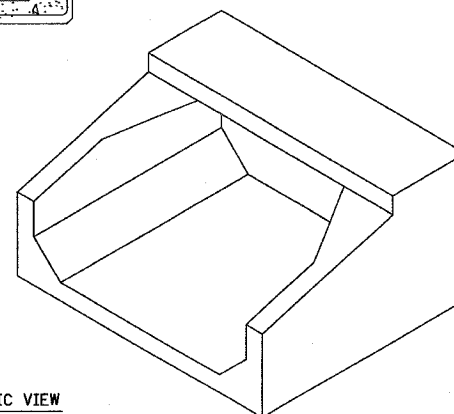

ISOMETRIC VIEW

SPAN X RISE	T (INCHES)	A (FT-IN)	B (FT-IN)	C (INCHES)	E (FT-IN)	F (FT-IN)	G (FT-IN)	H (FT-IN)	SLOPE (X:Y)
2' X 2'	4	2-8	2-8	4	3-0	3-0	1-0	1-0	3:1
3' X 2'	4	3-8	2-8	4	3-0	3-0	1-0	1-0	3:1
3' X 3'	4	3-8	3-8	4	2-0	4-0	1-8	1-4	3:1
4' X 2'	5	4-10	2-10	5	3-0	3-0	1-0	1-0	3:1
4' X 3'	5	4-10	3-10	5	2-0	4-0	1-8	1-4	3:1
4' X 4'	5	4-10	4-10	5	2-0	4-0	2-0	2-0	2:1
5' X 2'	6	6-0	3-0	6	3-0	3-0	1-0	1-0	3:1
5' X 3'	6	6-0	4-0	6	2-0	4-0	1-8	1-4	3:1
5' X 4'	6	6-0	5-0	6	2-0	4-0	2-0	2-0	2:1
5' X 5'	6	6-0	6-0	6					
6' X 2'	7	7-2	3-2	7	3-0	3-0	1-0	1-0	3:1
6' X 3'	7	7-2	4-2	7	2-0	4-0	1-8	1-4	3:1
6' X 4'	7	7-2	5-2	7	2-0	4-0	2-0	2-0	2:1
6' X 5'	7	7-2	6-2	7					
6' X 6'	7	7-2	7-2	7					
7' X 4'	8	8-4	5-4	8	2-0	4-0	2-0	2-0	2:1
7' X 5'	8	8-4	6-4	8					
7' X 6'	8	8-4	7-4	8					
7' X 7'	8	8-4	8-4	8					
8' X 4'	8	9-4	5-4	8	2-0	4-0	2-0	2-0	2:1
8' X 5'	8	9-4	6-4	8					
8' X 6'	8	9-4	7-4	8					
8' X 7'	8	9-4	8-4	8					
8' X 8'	8	9-4	9-4	8					
9' X 5'	9	10-6	6-6	9					
9' X 6'	9	10-6	7-6	9					
9' X 7'	9	10-6	8-6	9					
9' X 8'	9	10-6	9-6	9					
9' X 9'	9	10-6	10-6	9					
10' X 4'	10	11-8	5-8	10					
10' X 5'	10	11-8	6-8	10					
10' X 6'	10	11-8	7-8	10					
10' X 7'	10	11-8	8-8	10					
10' X 8'	10	11-8	9-8	10					
10' X 9'	10	11-8	10-8	10					
10' X 10'	10	11-8	11-8	10					
11' X 4'	11	12-10	5-10	11					
11' X 6'	11	12-10	7-10	11					
11 X 8'	11	12-10	9-10	11					
11' X 10'	11	12-10	11-10	11					
11' X 11'	11	12-10	12-10	11					
12' X 4'	12	14-0	6-0	12					
12' X 6'	12	14-0	8-0	12					
12' X 8'	12	14-0	10-0	12					
12' X 10'	12	14-0	12-0	12					
12' X 12'	12	14-0	14-0	12					

NOT TO SCALE

REVISIONS	
NAME	DATE

ILLINOIS DEPARTMENT OF TRANSPORTATION

**PRECAST CONCRETE  
BOX CULVERT  
SN 082-2567**

FAU ROUTE 9170  
SECTION 124-21  
ST. CLAIR COUNTY

DRAWN BY:

PLOT DATE: 3/13/2006